



INCORPORATING WAYNE KERR INSTRUMENTS

Instruction/Service Manual  
for

**'E' SERIES BENCH POWER SUPPLIES**

HANDBOOK

Part N° 9HEB

FARNELL INSTRUMENTS LIMITED, SANDBECK WAY, WETHERBY, WEST YORKSHIRE LS22 4DH, UK

TELEPHONE (UK) 0937 581961      TELEX 557294      FAX (UK) 0937 586908

(INT) +44 937 581961

(INT) +44 937 586908

# **'E' SERIES BENCH POWER SUPPLIES**

**HANDBOOK**

**Part N° 9HEB**

**Farnell Instruments Ltd., Sandbeck Way, Wetherby, West Yorkshire LS22 4DN**

**Tel 0937 581961 Fax 0937 586908**

**Ver 2.0 17/12/91 PMA**

©Farnell Electronics plc. 1991

The copyright in this work is vested in Farnell Electronics plc and this document is issued for the purposed only for which it is supplied. No licence is implied for the use of any patented feature. It must not be reproduced in whole or in part, or used for tendering or manufacturing purposed except under an agreement or with the consent in writing of Farnell Electronic plc and then only on the condition that this notice is included in any such reproduction. Information furnished is believed to be accurate by no liability in respect of any use of it is accepted by Farnell Electronic plc.

## SAFETY

### GENERAL

This equipment has been designed to meet the requirements of IEC publication 348, "Safety Requirements for Electronic Measuring Apparatus", and has left the factory in a safe condition.

The remainder of this section on safety provides information and warnings which must be followed by the user to ensure safe operation and maintain the equipment in a safe condition.

### A.C. POWER SUPPLY

1) If it is necessary to fit a suitable a.c. power plug to the power cable, the user must observe the following colour codes:

LIVE terminal to BROWN lead  
NEUTRAL terminal to BLUE lead  
EARTH terminal to GREEN/YELLOW lead.

The user must also ensure that the protective earth lead would be the last to break should the cable be subject to excessive strain.

2) If the power cable electrical connection to the a.c. power plug is through screw terminals then, to ensure reliable connections, any solder tinning of the cable wires must be removed before fitting the plug.

3) **WARNING!** Any interruption of the protective earth conductor inside or outside the equipment or disconnection of the protective earth terminal is likely to make the equipment dangerous. Intentional interruption is prohibited.

4) Before switching on the equipment, ensure that it is set to the voltage of the local a.c. power supply.

### ADJUSTMENT, REPLACEMENT OF PARTS, MAINTENANCE AND REPAIR

1) When the equipment is connected to the local a.c. power supply internal terminals may be live and the opening of the covers or removal of parts (except those to which access can be gained by hand) is likely to expose live parts. The equipment must be disconnected from all voltage sources before it is opened for any adjustments, replacement maintenance or repair.

2) Capacitors inside the equipment may still be charged even if the equipment has been disconnected from all voltage sources.

- 3) Any adjustment, maintenance and repair of the opened equipment under voltage must be carried out by a skilled person who is aware of the hazards involved.
- 4) Ensure that only fuses with the required rated current and of the specified type are used for replacement. The use of makeshift fuses and short circuiting of fuse holders is prohibited.

## STATIC ELECTRICITY

The unit supplied may use static devices and service personnel should be alerted to components which require handling precautions to avoid damage by static electrical discharge.

Before handling circuit board assemblies containing these components, personnel should observe the following precautions:

- 1) The work surface should be a conductive grounded mat.
- 2) Soldering irons must be grounded and tools must be in contact with a conductive surface to ground when not in use.
- 3) Any person handling static sensitive parts must wear a wrist strap which provides a leaky path to ground, impedance not greater than 1 megaohm.
- 4) Components or circuit board assemblies must be stored in or on conductive foam or mat while work is in progress.
- 5) New components should be kept in the suppliers packaging until required for use.

## DISPOSAL HAZARDS

Service personnel should be aware of the following:

- 1) Cathode ray tubes can implode if subject to excessive mechanical shock.
- 2) Batteries should be disposed of intact and never incinerated.
- 3) Beryllium oxide washers must be disposed of intact as toxic waste.
- 4) Many components contain polymers which will give rise to toxic fumes if incinerated.

---

## CONTENTS

1.	SCHEDULE OF EQUIPMENT .....	2
2.	INTRODUCTION.....	3
3.	SPECIFICATION.....	4
4.	INSTALLATION.....	6
5.	OPERATING INSTRUCTIONS .....	7
6.	APPLICATIONS .....	8
7.	CIRCUIT DESCRIPTION .....	9
8.	RECALIBRATION.....	10
9.	MAINTENANCE.....	11
10.	CIRCUIT DIAGRAMS.....	12

## 1. SCHEDULE OF EQUIPMENT

The instrument has been carefully packed to prevent damage in transit. When removing the unit from box be sure to remove all parts and accessories from the packing material.

The complete equipment comprises:-

- a) 1 off E30-1B, E30-1BT, E30-2B, E30-2BT power supply as ordered.
- b) 1 off Instruction Book. (Part N° 9HEB)

*Note: In the event of damage in transit or shortage in delivery separate notices in writing should be given to both the carriers and Farnell Instruments Ltd., within three days of receipt of the goods, followed by a complete claim within five days. All goods which are the subject of any claim for damage in transit or shortage in delivery should be preserved intact as delivered for a period of seven days after making the claim, pending instructions or inspection by Farnell Instruments Ltd., or an authorised agent of Farnell Instruments Ltd.*

## 2. INTRODUCTION

This book covers all models in the E/B series of stabilised bench power supplies. The series offer a choice of output voltage and output current.

By use of a slider switch the precision analogue meter is used to display output voltage or output current. A push button switch is used to turn the power supply on and off. A green LED is used to indicate the power 'on' condition. A 10 turn precision potentiometer is used to vary the output voltage over its range from near zero to its maximum rating.

The power supply is protected against current overloads by electronic current limiting preset at approximately 110% of the nominal output current rating. In operation this circuit remains approximately constant. On removal of the overload the output will reset to its original value.

The current limit condition is indicated by a red LED near the output terminals.

The power supply incorporates circuitry that gives limited protection against the application of external voltages in the reverse and forward mode and thus the unit may be used for battery charging and parallel applications.

### 3. SPECIFICATION

<b>Mains Input</b>	220 or 240V a.c. 50/60Hz $\pm$ 10% change by external slide switch. (110 or 120V 50/60Hz to special order)
<b>D.C. Output</b>	E30-1B 0 - 30 Volts at 1amp E30-2B 0 - 30 Volts at 2amp E30-1BT Twin 0-30 Volts at 1amp E30-2BT Twin 0-30 Volts at 2amp
<b>Line Regulation</b>	Less than 0.01% +2mV for 10% change from nominal
<b>Load Regulation</b>	Less than 0.01% +2mV for zero to full load change
<b>Ripple and Noise</b>	Less than 1mV r.m.s. at full load ( f = 80kHz)
<b>Temperature Co-efficient</b>	0.04% per °C typical
<b>Protection</b>	Fuse protection on mains input and d.c. output. Electronic current limiting on d.c. output. Reverse polarity protection. Forward protection when input off allows battery charging.
<b>Indicators</b>	Current limit - panel mounted red LED Input power 'on' - panel mounted green LED
<b>Meter</b>	Analogue meter scaled in voltage and current scale length 78mm typical. Accuracy $\pm$ 3% of fsd.
<b>D.C. Float Voltage</b>	Either output terminal can be floated up to 200V d.c. above chassis (safety earth)
<b>Terminals</b>	D.C. output - colour coded 4mm binding post with cross wire hole. Earth - M3 insert on base of unit.
<b>Operating Temperature</b>	0°C to 35°C at full current linearly derate to 60% current at 55°C
<b>Storage Temp Range</b>	-20°C to +60°C

**Cooling** Convection cooled with exposed heatsink.

**Insulation Test** 1500V a.c. input to earth  
1500V a.c. input to output  
500V a.c. output to earth

**Safety** Designed to meet IEC 348 "Safety of Electrical Measuring Equipment"

**Dimensions & Weight**

Unit	E301B	E302B	E301BT	E302BT	
Height	150	150	150	150	mm
Width	112	125	215	240	mm
Depth	230	250	230	250	mm
Weight	2.7	4.0	5.2	7.7	kg

#### 4. INSTALLATION

The power supply is normally factory set for 240V a.c. operation however check that the position of the voltage selector slider switch on the base of the unit matches the local mains supply (units for operation on 110V/120V are available to special order).

The free end of the mains lead should be connected via a suitable plug to the local mains supply. The colour code used in the mains lead is as follows:

Brown - Live

Blue - Neutral

Green/Yellow - Ground safety earth

The E/B series of power supplies is classified as Safety class 1 equipment and it is imperative that the mains earth lead (green/yellow) is connected to a known integrity ground otherwise the chassis may float to a dangerous potential.

The unit is convection cooled and care should be taken to ensure that the air flow is not obstructed.

It should be noted that the exposed heatsink may be hot.

## 5. OPERATING INSTRUCTIONS

### First Time Operation

Before turning 'on' confirm that the unit is set for use on the local mains supply.

Select 'volts' on the meter switch and depress the input switch to 'on' and note the green LED is illuminated. Rotate the voltage control and confirm that the output voltage can be varied from zero to at least the rated voltage.

Slide the meter switch to Amps, short circuit the output terminals and confirm that the unit current limits at approximately 110% of nominal rating and that the red current LED is illuminated. Remove short circuit. The power supply is now ready for use.

### General

The power supply can be used at any point within its nominal rating. Due to circuit tolerances units will be able to offer outputs in excess of the rated voltage and current without damage but in this region the performance is not specified.

The nominal working region is indicated by the broad scale bands on the meter. Connections to the binding posts can be made using 4mm lead, spade end leads, or bare wire. A safety earth connection is available on the base of the unit.

### Overload Protection

The current limit facility provides automatic protection in the event of accidental short circuits or overloads. The current limit point is approximately 110% of the nominal output current. With progressive overload the output voltage falls while the current remains approximately constant. On removal of the overload, the power supply will automatically revert to supplying the set voltage.

### Fuses

The mains input and regulated d.c. output are each protected by fuses accessible on the base of the unit.

### WARNING

**Before replacing any fuse ensure the unit is isolated from the mains supply.**

To minimise fire hazard use correct replacement fuses. The mains input is 5 x 20mm size time delay, (T) type whilst the d.c. output is 5 x 20mm fast (F) type. The value of each is indicated on the base of the unit.

## 6. APPLICATIONS

To maintain good regulation at the load, short lengths of wire should be used. The gauge of wire should be chosen to give minimum voltage drop at the current drawn.

In applications where regulation is not critical resulting in long lead being used, it is recommended that a capacitor, of value at least 100uF, is placed at the load end.

### **Parallel Operation**

Parallel operation. To increase the current availability parallel operation is possible with these units. The power supplies should be set to give as near equal output voltage as possible and then connected in parallel. In use the unit with the slightly higher voltage will deliver current up to its current limit point. At this stage the output voltage falls slightly to that of the second power supply which now starts delivering current.

### **Battery Charging**

Battery charging is possible with these units. However if it is intended to stop charging by turning off the mains supply then it should be remembered that circuitry within the unit will present a small 'bleed' on the battery.

## 7. CIRCUIT DESCRIPTION

The power supply is based on a compound series regulator controlled by a voltage comparator and a current limit clamp.

A reduced and isolated voltage is provided by TX301 to bridge BR101 and reservoir capacitors C101-C108 on E30/2B to give a raw d.c. supply at the collectors of the series regulator Q102-Q105. Q101 is used to give current gain. The output current from the compound regulator is passed via close tolerance resistors R1, R2, R3, R4, which form a precision current shunt.

A second winding on TX301 via D1 and C1 provide raw d.c. for the control circuits. A fixed 12 volt regulator U2 provides a well regulated and smoothed line that is split via D4 and D5 to give -1.4 and +10.6 about the +ve sense line.

The comparators (U1-A, U1-B) are formed by an LM358 dual op amp capable of working with both inputs near its -ve terminal.

To minimise switch on/off aberration, R10 holds the series regulators off in the absence of any output from the voltage comparator U1-A.

U1-A as part of the feedback loop attempts to maintain zero voltage between its inputs by offsetting the reference voltage formed across R14. Thus if the output increases, the negative sense line goes more negative, thus pulling pin 3 and pin 1 in turn more negative. This "turns off" the regulator thereby reducing the output voltage to the equilibrium value.

The current limit clamp compares the voltage developed across the precision shunt (R1-4) via the potential divider R6 and R8, with the voltage derived from the reference zener Z1 and divider R5 and R6.

Whilst the current flowing is less than the current limit point and hence the voltage across (R1-4) is less than the reference voltage, pin 7 is held high. As the current limit point is reached pin 7 is moved low and 'robs' the base drive to the series regulators provided by R9, and thus progressively reduces the output voltage. Pin 7 going low also forward biases LD202 causing it to illuminate to indicate the current limit condition.

P201 and R203 allow the meter to be calibrated to 0.5V fsd for current measuring purposes. In the voltage mode R201 and R292 form a potential divider.

Reverse polarity protection is provided by D201 and forward polarity protection by D101.

## 8. RECALIBRATION

The only user adjustable preset control on this unit is the meter calibration. This control is accessible through a small hole in the lower front panel flange. Use a small trimming tool to engage a flat blade in the pcb mounted preset.

Set the unit to give, say, 5 volts output and connect an ammeter of known accuracy to act as a short circuit across the output. Switch 'on' and select amps, adjust the preset meter calibration until the unit ammeter matches the reference. Switch 'off' and remove the ammeter.

Connect a voltmeter of known accuracy across the output terminals, switch 'on' and select volts. Confirm that the voltmeter is within the specification accuracy figure.

The accuracy of the voltage scales is dependent mainly upon the accuracy of the resistors used in the potential divider.

### Fuses

It should be remembered that fuses have a finite life particularly when running at their rated current and users may wish, as a preventative maintenance measure, to replace fuses after 5,000 hours of operation.

### Access to Unit

**Warning:** Disconnect from mains supply and wait at least 10 minutes for internal capacitors to discharge.

## 9. MAINTENANCE

### GUARANTEE

The equipment supplied by Farnell Instruments Limited is guaranteed against defective material and faulty manufacture for a period of twelve months from the date of despatch. In the case of material or components employed in the equipment but not manufactured by us, we allow the customer the period of any guarantee extended to us.

The equipment has been carefully inspected and submitted to comprehensive test at the factory prior to despatch. If, within the guarantee period, any defect is discovered in the equipment in respect of material or workmanship and reasonably within our control, we undertake to make good the defect at our own expense subject to our standard conditions of sale. In exceptional circumstances and at the discretion of the Service Manager, a charge for labour and carriage costs incurred may be made.

Our responsibility is in all case limited to the cost of making good the defect in the equipment itself. The guarantee does not extend to third parties, nor does it apply to defects caused by abnormal conditions of working, accidents, misuse, neglect or wear and tear.

### MAINTENANCE

In the event of difficulty or apparent circuit malfunction, it is advisable to telephone (or Telex) the Service Department or your local Sales Engineer or Agent (if overseas) for advice before attempting repairs.

For repairs and recalibration it is recommended that the complete unit be returned to:

The Service Department  
Farnell Instrument Limited  
Osborn House  
Sandbeck Way,  
Wetherby,  
West Yorkshire LS22 4DN

Tel: (0937) 585215 Fax. (0937) 586908

Please ensure adequate care is taken with packing and arrange insurance cover against transit damage or loss.

10. CIRCUIT DIAGRAMS

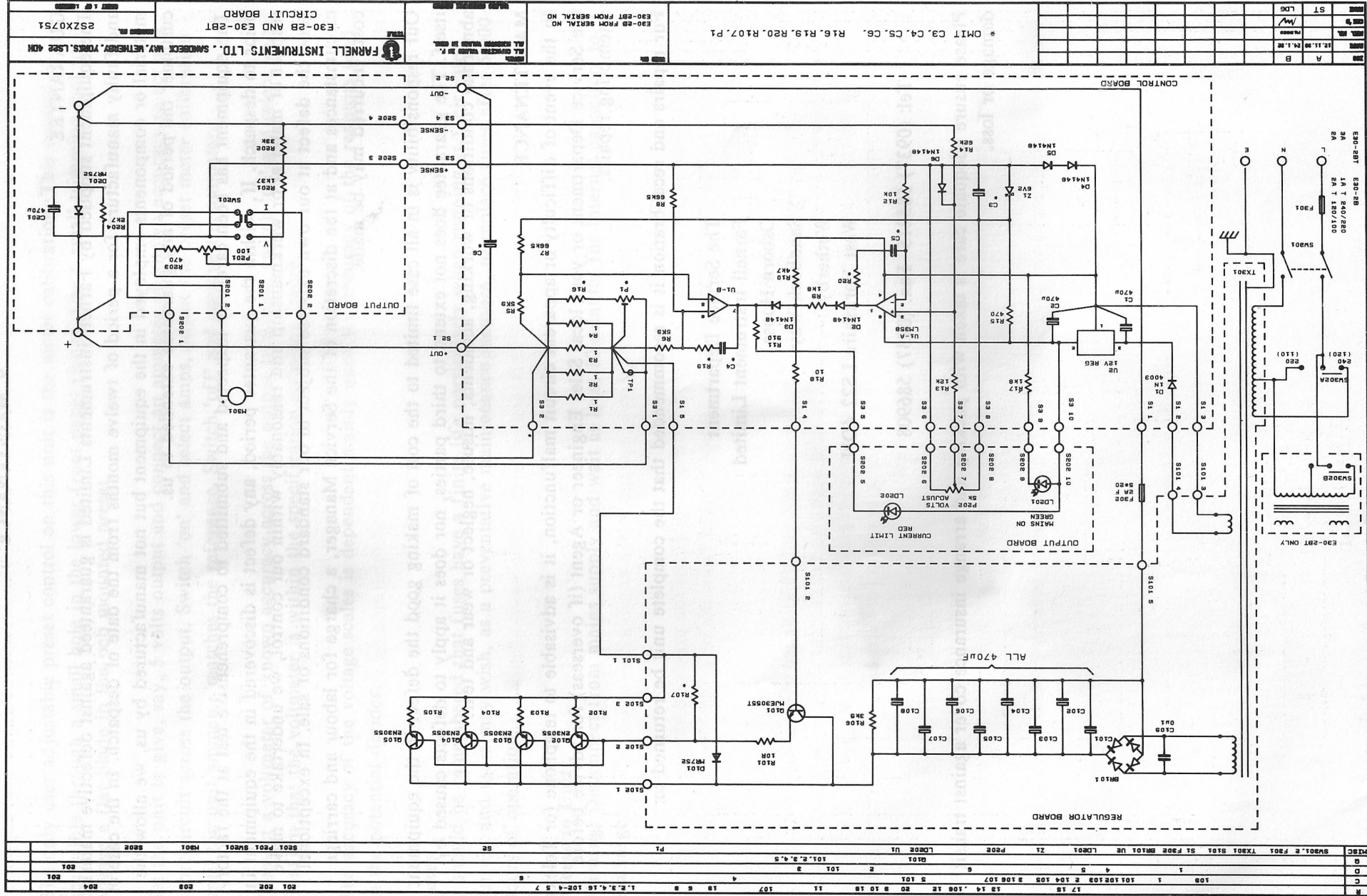

FARNELL INSTRUMENTS LTD., SANDHECK WAY, WETHEBY, YORKS. LS22 4DN  
 E30-28 AND E30-28T CIRCUIT BOARD 2S2X0751  
 E30-28 FROM SERIAL NO. E30-28T FROM SERIAL NO.  
 \* OMIT C3, C4, C5, C6, R16, R19, R20, R407, P1

R				17 15		13 14	.106 12	20 8 10 18	11	101.2.3.4.5	18 6 8	1.2.3.4.16	5 7										
C		105 106 1	101 102 2	103 3 104		5		2	101 3	4			6										
D		1	4 5		6														201				
Q									101.2.3.4.5										201				
MISC	SW301.2	F301	TX301	S101	S1	F302	BR101	U2	LD201	Z1	P202	LD202	U1	F1	SE				SE01	PE01	SW201	MS01	SE02

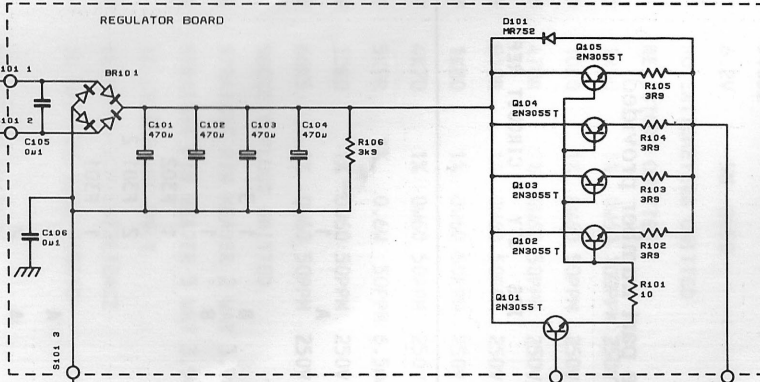

\* COMPONENT VARIATIONS

	E30-1B	E30-1BT
F301	240/220V 1A T TYPE 5 X 20mm	240/220V 2A T TYPE 5 X 20mm
	120/110V 2A T TYPE 5 X 20mm	120/110V 3A T TYPE 5 X 20mm

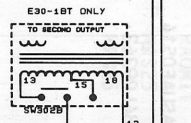
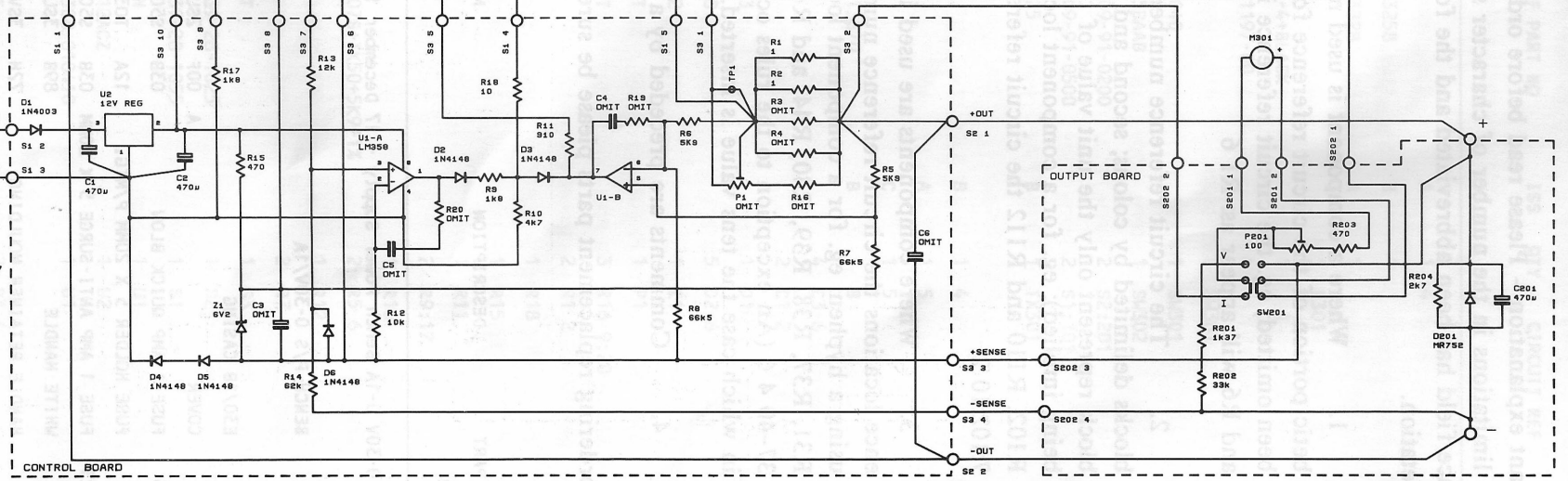
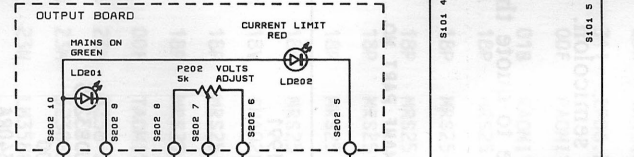

REV	A	B	C	D	E
DATE	10/11/88	17.1.89	22.7.89	28.10.89	27.1.89
REV. NO.	14383	14387	14933	15020	
REV. BY				MW	
REV. NO.	AC	LD6	ST	ST	LD6

REV. NO.  
E30/1B FROM SERIAL NO 201  
E30/1BT FROM SERIAL NO 101

FARNELL INSTRUMENTS LTD., SANDHECK WAY, WETHERBY, YORKS, LS22 4DN

E30-1B AND E30-1BT  
CIRCUIT DIAGRAM

REV. NO. 25ZX0465

## 11. COMPONENT LISTS

Important explanation - Please read before ordering parts.

Due to limitations in the number of character spaces available the information in the circuit reference field has been abbreviated and the following notes are provided as a guide to its interpretation.

1. Where a component is used more than once on an assembly the alphabetic portion of the circuit reference for its second and subsequent locations has been omitted; eg. the circuit reference information for a component located at R1 and R6 will appear as: R1 6

2. The circuit reference numbers are presented in ascending decade blocks delimited by colons; second and subsequent numbers within a decade block represent only the unit value of the location (the tens and hundreds values being implied); eg. for a component located at R54, R57, R59, R82, R82, R87, R102, R110 and R112 the circuit reference entry will be: R54 7 9:82 7 9:82 7:102:10 2.

3. Where components are used in a series of neighbouring circuit reference locations the circuit reference numbers are represented as inclusive blocks using a hyphen; eg. for a component located at R16, R19, R21, R24, R25, R26, R31, R37, R38, R39, R40, R44, and R46 will be represented as R16 9:21 4-6: 31 37-40 4 6 (An exception to the rules occurs when a series crosses a decade block in which case the tens value is inserted.

4. Comments are preceded by a semicolon.

When ordering replacement parts please be sure to quote the part number provided.

FARNELL PART NUMBER	DESCRIPTION	MANF PART NO	ISS	QTY	CIRCUIT REF
---------------------	-------------	--------------	-----	-----	-------------

E30-1B 0-30V 0-1A Bench Power Supply - 17 December 1991

21E301B	BENCH P/S 0-30V/1A		A	1	
31E301B	E30/1B CASING		B	1	3
7SU3265	COVER	A 00F 2SUD83265	B	1	
FF1A0013	FUSE 1 AMP QUICK BLOW	03B S500		1	F302
FH340RA	FUSE HOLDER 5 X 20MM P/MTG.	12A T0340RA		2	F301 2
FT1A00123	FUSE 1 AMP ANTI-SURGE 5 X 20MM	03B S502		1	F301
HA04517	WHITE HANDLE	89B 3SU004517	A	1	
HMO108	HANDLE RETAINER MOULDING	72H 3SV0108	A	2	
HR0514	L30 HANDLE RET	22P ASUAE0514	A	2	
JP7A	BOX NUMBER 7	20R 84L09262		1	

FARNELL PART NUMBER	DESCRIPTION	MANF PART NO	ISS	QTY	CIRCUIT REF
4NE301BC	CHASSIS ASM E30/1B		A	1	4
7SU3258	CHASSIS	A 00F 2SUSJ3258	B	1	
7SU3328	PACKING PIECE	00F 4SUDA3328	A	1	
FS9820	FUSE HOLDER SHROUD 5 X 20MM	28B 9820		1	F301
GC5P4	STRAIN RELIEF BUSH 2.5MM PANEL	30H SR-5P-4+BLACK		1	
HFSTD	FOOT 103-E119700	37F 103-E1197-00		4	
SA5000A	TRANSPARENT SWITCH COVER	45L 5000A		1	SW301
SB5040	MAINS SWITCH 4 WAY	45L PBMS5040		1	SW301
SS22105BNM	SEL T22105BAAB UNMARKED	12A T22105BAAB		1	SW302
TBM3902HS	CRIMP HOUSING 2 WAY 3.96MM	23M 3069+09-91-0200		2	S2:201
TBM3905HS	CRIMP HOUSING 5 WAY 3.96MM	23M 3069+09-91-0500		2	S1:101
ZR0325	E30/1B 240V	01B 3SR0325	B	1	TX301
4NE301BF	FRONT PANEL ASSEMBLY		B	1	4
5NE301BC	NON-STANDARD CONTROL C.B.		A	1	5
5SEBC	STD. CONT. CB COMPS. E15/E30		C	1	5
BC1387	E30 CONTROL BOARD	03C N1SAK13870	B	1	B
CAOMIT	CAPACITORS OMITTED			4	C3-6
CEC470UIM	470UF 20% 40V R050	134N KMV8		2	C1 2
DG4003	DIODE	11G 1N4003		1	D1
DG4148	DIODE	23N 1N4148		5	D2-6
DZ16V20E	6.2V 5% 0W50	31I ZPD6.2		1	Z1
PAOMIT	POTENTIOMETERS OMITTED	00F PAOMIT		1	P1
RAOMIT	RESISTORS OMITTED	01B RAOMIT		3	R16 9:20
RM11R00FF	1R00 1% 0W60 100PPM 250V	18P MRS25		2	R1 2
RM210R0FF	10R0 1% 0W60 50PPM 250V	18P MRS25		1	R18
RM3470RFF	470R 1% 0W60 50PPM 250V	18P MRS25		1	R15
RM3910RFF	910R 1% 0W60 50PPM 250V	18P MRS25		1	R11
RM41K80FF	1K80 1% 0W60 50PPM 250V	18P MRS25		2	R9:17
RM44K70FF	4K70 1% 0W60 50PPM 250V	18P MRS25		1	R10
RM45K90FF	5K9R 1% 0.6W 50PPM 6.5mm	18V SMA0207S+TK50+5K9+1%		2	R5 6
RM510K0FF	10K0 1% 0W60 50PPM 250V	18P MRS25		1	R12
RM566K5FF	66K5 1% 0W60 50PPM 250V	18P MRS25		2	R7 8
TAOMIT	SOCKETS, PLUGS OMITTED	00F TAOMIT		1	S3
TBM3902PS	STRAIGHT PIN HEADER 2 WAY 3.96	23M 5238-39-28-1025		1	S2
TBM3905PS	STRAIGHT PIN HEADER 5 WAY 3.96	23M 5238-39-28-1055		1	S1
VA358N	IC LM358N NSC ONLY	23N LM358N		1	U1
VA78L12CP	IC MC78L12CP/LM78L12ACZ	23N LM78L12ACZ		1	U2
VS8P	IC SKT 703-1308-010410	28I 703-1308-010410		1	U1
RAOMIT	RESISTORS OMITTED	01B RAOMIT		2	R3 4
RM512K0FF	12K0 1% 0W60 50PPM 250V	18P MRS25		1	R13
RM562K0FF	62K0 1% 0W60 50PPM 250V	18P MRS25		1	R14

FARNELL PART NUMBER	DESCRIPTION	MANF PART NO	ISS	QTY	CIRCUIT REF
5NE301BO	OUTPUT ASSEMBLY		B	1	5
BC1388	E30 OUTPUT BOARD	01K N1PAK13880	B	1	B
CEC470UIM	470UF 20% 40V R050	134N KMVB		1	C201
DG752	DIODE	02M MR752		1	D201
HC10W508	10W FLEXI 0.1 PITCH	01F FST22A10		1	S202
LD134G	LED GRN T1 3/4 MV64530	11Q MV64530+/+MP52+CLIP		1	LD201
LD134R	LED RED T1 3/4 MV5753	11Q MV5753		1	LD202
PM3100RMH	100R 20% PRESET HORZ STURN	02S 67X		1	P201
PW45K00JN	5K00 5% NPREST LIN	02S 534-5K		1	P202
RM3470RFF	470R 1% 0W60 50PPM 250V	18P MRS25		1	R203
RM41K37FF	1K37 1% 0W60 50PPM 250V	18P MRS25		1	R201
RM42K70FF	2K70 1% 0W60 50PPM 250V	18P MRS25		1	R204
RM533K0FF	33K0 1% 0W60 50PPM 250V	18P MRS25		1	R202
SS20201	S/SW L202-01-1-MS-02-Q	35R L202-01-1-MS-02-Q		1	SW201
TBM3902PS	STRAIGHT PIN HEADER 2 WAY 3.96	23M 5238-39-28-1025		1	S201
WN10M17	NYLON WASHER M10 X 17.45MM O/D	40P 041-3728		1	
7SU3256	FRONT PANEL	A 00F 2SUDD3256	C	1	
7SU3257	METER BRACKET	KA 00F 3SUDA3257	C	1	
EM0018	METER E30/1B	01S 3SMO00018	A	1	M301
HK151	NUTCOVER N151 SIF BLK	01S N151		1	
HKC210	KNOB CAP C210 BEIGE 271	01S C210+BEIGE+271		1	
HKS210	KNOB S210 BEIGE 271	01S S210+250+BEIGE+271		1	
KC3M6	SCREW M3 X 6 CSK HD POZI	05T KC3M6		2	
KP3M6	SCREW M3 X 6 PAN HD POZI	05T KP3M6		2	
NR3M10TH	SPACER M3 X 10MM THR'D HEX	01H R6374-02		1	
NR3M18TH	SPACER M3 X 18MM THR'D HEX	01H R6378-02		2	
SA0249	SWITH BUTTON "P" SERIES	01S 4SC0249	A	1	
TM4BLK	TERMINAL BLACK	50C TP4+(BLK)		1	
TM4RED	TERMINAL RED	50C TP4+(RED)		1	
TS4B164	SOLDER TAG 4BA	05R X		2	
WS3M	SPRING WASHER M3	05T WS3M		1	
WS4M	SPRING WASHER M4	05T WS4M		2	
WW25M	WAVEY WASHER M2.5	24L LS508/53		2	
WW3M	WAVEY WASHER M3	24L LS508/54		6	
4NE301BHS	HEATSINK ASSEMBLY		A	1	4
5NE301BR	REGULATOR NON-STANDARD		A	1	5
5SEBR	REGULATOR STANDARD BOARD		A	1	5
BC1384	E30 REGULATOR BOARD	03C N1SAK13840	B	1	B
CR6100NLM	100NF 20% 100V 7.5MM	159W MKS3		1	C105
CX6100NPM	100NF 20% 250V R200	13R PME+271M610M		1	C106
DBB80	BR. RECT. 25MM LDS 125V 5A	11G B80C/5000/3300		1	BR1
DG752	DIODE	02M MR752		1	D101
RM13R90FF	3R90 1% 0W60 100PPM 250V	18P MRS25		4	R102-105

FARNELL PART NUMBER	DESCRIPTION	MANF PART NO	ISS	QTY	CIRCUIT REF
RM210R0FF	10R0 1% 0W60 50PPM 250V 18P	MRS25		1	R101
TBM3905PS	STRAIGHT PIN HEADER 5 WAY 3.96	23M 5238-39-28-1055		1	S101
VAOMIT	TRANSISTORS/ICS OMITTED	00F IN+HOUSE+REFERENCE		4	Q102-105
VT3055T	TRANS MJE3055T	02M MJE3055T		1	Q101
CEC470UKM	470UF 20% 63V R075	134N KMVB		4	C101-104
RM43K90FF	3K90 1% 0W60 50PPM 250V 18P	MRS25		1	R106
		53D SMA0207TK50			
7AE30HS	E30 HEATSINK ASSEMBLY	FI 2DJ10370401	A	1	
7SU3259	HEATSINK PART "A"	K 00F 2SUBA3259	C	1	
7SU3261	HEATSINK PART "C"	K 00F 3SUBA3261	B	1	
7SU3262	HEATSINK PART "D"	K 00F 3SUBA3262	B	1	
7SU3263	HEATSINK PART "E"	00F 4SUBA3263	D	2	
7SU3924	L H HEATSINK E SERIES	00F 3SUBA3924	A	1	
7SU3925	R H HEATSINK E SERIES	00F 3SUBA3925	A	1	
7SU3264	4DA/A #TRANSISTR CLAMP#	00F 4SUDA3264	A	2	
MB56201	TOP HAT BUSH 6BA	01P 56201J		2	
MF3327	INSULATOR 36 X 25	33P 4SU003327	A	2	
VT3055T	TRANS MJE3055T	02M MJE3055T		4	Q102-105
WW3M	WAVEY WASHER M3	24L LS508/54		10	
6NE301B	WPA/A #E30/1B #F		A	1	6
8ZX0465	E15/2B E30/1B		D	1	
HL9X30	BLANK 9X30 P120	51D P120		1	

\*\*\*\*\*

E30-2B 0-30V 0-2A Bench Power Supply - 17 December 1991

21E302B	BENCH P/S 0-30V/2A		A	1	2
31E302B	CASING E30/2B		A	1	3
7SU4543	COVER	00F 1SUDJ4543	A	1	
FF2A0013	FUSE 2 AMP QUICK BLOW	03B S500		1	F302
FH340RA	FUSE HOLDER 5 X 20MM P/MTG.	12A TO340RA		2	F301 2
FT2A00123	FUSE 2 AMP ANTI-SURGE	03B S502		1	F301
HA04517	WHITE HANDLE	89B 3SU004517	A	1	
HMO108	HANDLE RETAINER MOULDING	72H 3SV0108	A	2	
HR0514	L30 HANDLE RET	22P ASUAE0514	A	2	
4NE302BC	CHASSIS ASM E30/2B		A	1	4
7SU3328	PACKING PIECE	00F 4SUDA3328	A	1	
7SU4541	CHASSIS	00F 1SUSJ4541	A	1	
7SU4997	TX SCREEN	00F 4SUBA4997	A	1	

FARNELL PART NUMBER	DESCRIPTION	MANF PART NO	ISS	QTY	CIRCUIT REF
FS9820	FUSE HOLDER SHROUD 5 X 20MM	28B 9820		2	F301 2
GC151	R.H. STRAIN RELIEF BUSH	30H SR-15-1+BLACK		1	
HFSTD	FOOT 103-E119700	37F 103-E1197-00		4	
KP3M10	SCREW M3 X 10 PAN HD POZI	05T KP3M10		2	
SA5000A	TRANSPARENT SWITCH COVER	45L 5000A		1	SW301
SB5040	MAINS SWITCH 4 WAY	45L PBMS5040		1	SW301
SS22105BNM	SEL T22105BAAB UNMARKED	12A T22105BAAB		1	SW302
TBM3902HS	CRIMP HOUSING 2 WAY 3.96MM	23M 3069+09-91-0200		2	S2:201
TBM3905HS	CRIMP HOUSING 5 WAY 3.96MM	23M 3069+09-91-0500		2	S1:101
WS4M	SPRING WASHER M4	05T WS4M		2	
WW3M	WAVEY WASHER M3	24L LS508/54		6	
ZR0332	E30/2B E30/2BT 240V	01B 3SR0332		1	TX301
4NE302BF	FRONT PANEL E30/2B		A	1	4
5NE301BO	OUTPUT ASSEMBLY		B	1	5
BC1388	E30 OUTPUT BOARD	01K N1PAK13880	B	1	B
CEC470UIM	470UF 20% 40V R050	134N KMVB		1	C201
DG752	DIODE	02M MR752		1	D201
HC10W508	10W FLEXI 0.1 PITCH	01F FST22A10		1	S202
LD134G	LED GRN T1 3/4 MV64530	11Q MV64530+/-MP52+CLIP		1	LD201
LD134R	LED RED T1 3/4 MV5753	11Q MV5753		1	LD202
PM3100RMH	100R 20% PRESET HORZ STURN	02S 67X		1	P201
PW45K00JN	5K00 5% NPREST LIN	02S 534-5K		1	P202
RM3470RFF	470R 1% 0W60 50PPM 250V	18P MRS25		1	R203
RM41K37FF	1K37 1% 0W60 50PPM 250V	18P MRS25		1	R201
RM42K70FF	2K70 1% 0W60 50PPM 250V	18P MRS25		1	R204
RM533K0FF	33K0 1% 0W60 50PPM 250V	18P MRS25		1	R202
TBM3902PS	STRAIGHT PIN HEADER 2 WAY 3.96	23M 5238-39-28-1025		1	S201
WN10M17	NYLON WASHER M10 X 17.45MM O/D	40P 041-3728		1	
5NE302BC	NON-STANDARD CONTROL			1	5
5SEBC	STD. CONT. CB COMPS. E15/E30		C	1	5
BC1387	E30 CONTROL BOARD	03C N1SAK13870	B	1	B
CAOMIT	CAPACITORS OMITTED			4	C3-6
CEC470UIM	470UF 20% 40V R050	134N KMVB		2	C1 2
DG4003	DIODE	11G 1N4003		1	D1
DG4148	DIODE	23N 1N4148		5	D2-6
DZ16V20E	6.2V 5% 0W50	31I ZPD6.2		1	Z1
PAOMIT	POTENTIOMETERS OMITTED	00F PAOMIT		1	P1
RAOMIT	RESISTORS OMITTED	01B RAOMIT		3	R16 9:20
RM11R00FF	1R00 1% 0W60 100PPM 250V	18P MRS25		2	R1 2
RM210R0FF	10R0 1% 0W60 50PPM 250V	18P MRS25		1	R18
RM3470RFF	470R 1% 0W60 50PPM 250V	18P MRS25		1	R15
RM3910RFF	910R 1% 0W60 50PPM 250V	18P MRS25		1	R11
RM41K80FF	1K80 1% 0W60 50PPM 250V	18P MRS25		2	R9:17

FARNELL PART NUMBER	DESCRIPTION	MANF PART NO	ISS	QTY	CIRCUIT REF
RM44K70FF	4K70 1% 0W60 50PPM 250V 18P	MRS25		1	R10
RM45K90FF	5K9R 1% 0.6W 50PPM 6.5mm 18V	SMA0207S+TK50+5K9+1%		2	R5 6
RM510K0FF	10K0 1% 0W60 50PPM 250V 18P	MRS25		1	R12
RM566K5FF	66K5 1% 0W60 50PPM 250V 18P	MRS25		2	R7 8
TAOMIT	SOCKETS,PLUGS OMITTED	00F TAOMIT		1	S3
TBM3902PS	STRAIGHT PIN HEADER 2 WAY 3.96	23M 5238-39-28-1025		1	S2
TBM3905PS	STRAIGHT PIN HEADER 5 WAY 3.96	23M 5238-39-28-1055		1	S1
VA358N	IC LM358N NSC ONLY	23N LM358N		1	U1
VA78L12CP	IC MC78L12CP/LM78L12ACZ	23N LM78L12ACZ		1	U2
VS8P	IC SKT 703-1308-010410	28I 703-1308-010410		1	U1
RM11R00FF	1R00 1% 0W60 100PPM 250V 18P	MRS25		2	R3 4
RM512K0FF	12K0 1% 0W60 50PPM 250V 18P	MRS25		1	R13
RM562K0FF	62K0 1% 0W60 50PPM 250V 18P	MRS25		1	R14
7SU3257	METER BRACKET	KA 00F 3SUDA3257	C	1	
7SU4542	FRONT PANEL	00F 2SUSF4542	A	1	
EM0021	E30/2 E30/2BT METER	01S 3SM000021	B	1	M201
HKC210	KNOB CAP C210 BEIGE 271	01S C210+BEIGE+271		1	
HKS210	KNOB S210 BEIGE 271	01S S210+250+BEIGE+271		1	
KC3M6	SCREW M3 X 6 CSK HD POZI	05T KC3M6		2	
KP3M6	SCREW M3 X 6 PAN HD POZI	05T KP3M6		2	
NR3M10TH	SPACER M3 X 10MM THR'D HEX	01H R6374-02		1	
NR3M18TH	SPACER M3 X 18MM THR'D HEX	01H R6378-02		2	
SA0249	SWITH BUTTON "P" SERIES	01S 4SC0249	A	1	
TM4BLK	TERMINAL BLACK	50C TP4+(BLK)		1	
TM4RED	TERMINAL RED	50C TP4+(RED)		1	
TS4B164	SOLDER TAG 4BA	05R X		2	
WS3M	SPRING WASHER M3	05T WS3M		1	
WS4M	SPRING WASHER M4	05T WS4M		2	
WW25M	WAVEY WASHER M2.5	24L LS508/53		2	
WW3M	WAVEY WASHER M3	24L LS508/54		6	
4NE302BHS	HEATSINK ASSEMBLY		A	1	4
5NE302BR	REGULATOR NON-STANDARD		A	1	
5SE302BR	REGULATOR STANDARD		A	1	5
BC1724	REGULATOR CB E302B	01K BC17240	A	1	B
CAOMIT	CAPACITORS OMITTED			1	C106
CR6100NLM	100NF 20% 100V 7.5MM	159W MKS3		1	C105
DBB80	BR. RECT. 25MM LDS 125V 5A	11G B80C/5000/3300		1	BR101
DG752	DIODE	02M MR752		1	D101
RAOMIT	RESISTORS OMITTED	01B RAOMIT		4	R102-05
RM210R0FF	10R0 1% 0W60 50PPM 250V 18P	MRS25		1	R101
TBM3905PS	STRAIGHT PIN HEADER 5 WAY 3.96	23M 5238-39-28-1055		1	S101

FARNELL PART NUMBER	DESCRIPTION	MANF PART NO	ISS	QTY	CIRCUIT REF
VAOMIT	TRANSISTORS/ICS OMITTED	00F IN+HOUSE+REFERENCE		4	Q102-05
VT3055T	TRANS MJE3055T	02M MJE3055T		1	Q101
WW3M	WAVEY WASHER M3	24L LS508/54		6	
CEC470UKM	470UF 20% 63V R075	134N KMVB		8	C101-04 07-10
RM43K90FF	3K90 1% 0W60 50PPM 250V	18P MRS25		1	R106
7SU4545	HEATSINK GUARD	00F 2SUDJ4545	A	1	
7SX4544	HEATSINK	00F 3SUBA4544	A	2	
AX0020	HEATSINK EXTRUSION	31C 4SX000020	A	0	
MB0015B	M3 INSULATING BUSH	72H 4SVOO0015B	E	8	
MC1	CERAMIC BEAD SMALL	57M 1PB/1		8	
MM3055	TRANSISTOR MICA TO3	70H DF377A		4	
NR3M12TH	SPACER M3 X 12MM THR'D HEX	01H R6334-02		4	
NR3M18MF	SPACER M3 X 18MM	33H C022L880018		4	
NR3M25TH	SPACER M3 X 25MM THR'D HEX	01H R100911C		4	
RM11R00FF	1R00 1% 0W60 100PPM 250V	18P MRS25		4	R102-105
VT3055	TRANS 2N3055 TE1912	29S 2N3055		4	Q102-105
WF3M	FLAT WASHER M3	05T WF3M		4	
WS3M	SPRING WASHER M3	05T WS3M		16	
99CR	COMPONENTS TO BE SPECIFIED			1	METALWORK
HL9X30	BLANK 9X30 P120	51D P120		1	

\*\*\*\*\*

E30-1BT 0-30V 0-2A Twin O/P Bench Power Supply - 17 December 1991

21E301BT	BENCH P/S 0-30V/1A TWIN O/P		A	1	
31ET301B	CASING ET30/1B		A	1	3
7SU4538	COVER	00F 1SUDJ4538	A	1	
FF1A0013	FUSE 1 AMP QUICK BLOW	03B S500		2	F302 X2
FH340RA	FUSE HOLDER 5 X 20MM P/MTG.	12A TO340RA		3	F301 2 +1
FT2A00123	FUSE 2 AMP ANTI-SURGE	03B S502		1	F301
		31W 19195			
HA04517	WHITE HANDLE	89B 3SU004517	A	1	
HM0108	HANDLE RETAINER MOULDING	72H 3SV0108	A	2	
HR0514	L30 HANDLE RET	22P ASUAE0514	A	2	
4NET301BC	CHASSIS ASM ET30/1B		A	1	4
7SU3328	PACKING PIECE	00F 4SUDA3328	A	1	
7SU4536	CHASSIS	00F 1SUSJ4536	A	1	
FS9820	FUSE HOLDER SHROUD 5 X 20MM	28B 9820		3	F301 2 +1
GC5P4	STRAIN RELIEF BUSH 2.5MM PANEL	30H SR-5P-4+BLACK		1	
HFSTD	FOOT 103-E119700	37F 103-E1197-00		4	
KP3M10	SCREW M3 X 10 PAN HD POZI	05T KP3M10		2	

FARNELL PART NUMBER	DESCRIPTION	MANF PART NO	ISS	QTY	CIRCUIT REF
NF4M	FULL NUT M4	05T NF4M		4	
SA5000A	TRANSPARENT SWITCH COVER	45L 5000A		1	SW301
SB5040	MAINS SWITCH 4 WAY	45L PBMS5040		1	SW301
SS22105BNM	SEL T22105BAAB UNMARKED	12A T22105BAAB		1	SW302
TBM3902HS	CRIMP HOUSING 2 WAY 3.96MM	23M 3069+09-91-0200		4	S2:201
TBM3905HS	CRIMP HOUSING 5 WAY 3.96MM	23M 3069+09-91-0500		4	S1:101
WF4M	FLAT WASHER M4	05T WF4M		4	
WS4M	SPRING WASHER M4	05T WS4M		4	
ZR0325	E30/1B 240V	01B 3SR0325	B	2	TX301 X2
4NET301BF	FRONT PANEL ET30/1B		A	1	4
5NE301BC	NON-STANDARD CONTROL C.B.		A	2	
5SEBC	STD. CONT. CB COMPS. E15/E30		C	1	5
BC1387	E30 CONTROL BOARD	03C N1SAK13870	B	1	B
CAOMIT	CAPACITORS OMITTED			4	C3-6
CEC470UIM	470UF 20% 40V R050	134N KMVB		2	C1 2
DG4003	DIODE	11G 1N4003		1	D1
DG4148	DIODE	23N 1N4148		5	D2-6
DZ16V20E	6.2V 5% 0W50	31I ZPD6.2		1	Z1
PAOMIT	POTENTIOMETERS OMITTED	00F PAOMIT		1	P1
RAOMIT	RESISTORS OMITTED	01B RAOMIT		3	R16 9:20
RM11R00FF	1R00 1% 0W60 100PPM 250V	18P MRS25		2	R1 2
RM210R0FF	10R0 1% 0W60 50PPM 250V	18P MRS25		1	R18
RM3470RFF	470R 1% 0W60 50PPM 250V	18P MRS25		1	R15
RM3910RFF	910R 1% 0W60 50PPM 250V	18P MRS25		1	R11
RM44K70FF	4K70 1% 0W60 50PPM 250V	18P MRS25		1	R10
RM45K90FF	5K9R 1% 0.6W 50PPM 6.5mm	18V SMA0207S+TK50+5K9+1%		2	R5 6
RM510K0FF	10K0 1% 0W60 50PPM 250V	18P MRS25		1	R12
RM566K5FF	66K5 1% 0W60 50PPM 250V	18P MRS25		2	R7 8
TAOMIT	SOCKETS,PLUGS OMITTED	00F TAOMIT		1	S3
TBM3902PS	STRAIGHT PIN HEADER 2 WAY 3.96	23M 5238-39-28-1025		1	S2
TBM3905PS	STRAIGHT PIN HEADER 5 WAY 3.96	23M 5238-39-28-1055		1	S1
VA358N	IC LM358N NSC ONLY	23N LM358N		1	U1
VA78L12CP	IC MC78L12CP/LM78L12ACZ	23N LM78L12ACZ		1	U2
VS8P	IC SKT 703-1308-010410	28I 703-1308-010410		1	U1
RAOMIT	RESISTORS OMITTED	01B RAOMIT		2	R3 4
RM512K0FF	12K0 1% 0W60 50PPM 250V	18P MRS25		1	R13
RM562K0FF	62K0 1% 0W60 50PPM 250V	18P MRS25		1	R14
5NE301BO	OUTPUT ASSEMBLY		B	2	
BC1388	E30 OUTPUT BOARD	01K N1PAK13880	B	1	B
CEC470UIM	470UF 20% 40V R050	134N KMVB		1	C201
DG752	DIODE	02M MR752		1	D201
HC10W508	10W FLEXI 0.1 PITCH	01F FST22A10		1	S202

FARNELL PART NUMBER	DESCRIPTION	MANF PART NO	ISS	QTY	CIRCUIT REF
LD134G	LED GRN T1 3/4 MV64530	11Q MV64530+/-MP52+CLIP		1	LD201
LD134R	LED RED T1 3/4 MV5753	11Q MV5753		1	LD202
PM3100RMH	100R 20% PRESET HORZ STURN	02S 67X		1	P201
PW45K00JN	5K00 5% NPREST LIN	02S 534-5K		1	P202
RM3470RFF	470R 1% 0W60 50PPM 250V	18P MRS25		1	R203
RM41K37FF	1K37 1% 0W60 50PPM 250V	18P MRS25		1	R201
RM42K70FF	2K70 1% 0W60 50PPM 250V	18P MRS25		1	R204
RM533K0FF	33K0 1% 0W60 50PPM 250V	18P MRS25		1	R202
SS20201	S/SW L202-01-1-MS-02-Q	35R L202-01-1-MS-02-Q		1	SW201
TBM3902PS	STRAIGHT PIN HEADER 2 WAY 3.96	23M 5238-39-28-1025		1	S201
WN10M17	NYLON WASHER M10 X 17.45MM O/D	40P 041-3728		1	
7SU3257	METER BRACKET	KA 00F 3SUDA3257	C	2	
7SU4537	FRONT PANEL	00F 1SUSJ4537	A	1	
EM0018	METER E30/1B	01S 3SMO00018	A	2	
HK151	NUTCOVER N151 SIF BLK	01S N151		2	
HKC210	KNOB CAP C210 BEIGE 271	01S C210+BEIGE+271		2	
HKS210	KNOB S210 BEIGE 271	01S S210+250+BEIGE+271		2	
KC3M6	SCREW M3 X 6 CSK HD POZI	05T KC3M6		4	
KP3M6	SCREW M3 X 6 PAN HD POZI	05T KP3M6		4	
NR3M10TH	SPACER M3 X 10MM THR'D HEX	01H R6374-02		2	
NR3M18TH	SPACER M3 X 18MM THR'D HEX	01H R6378-02		4	
SA0249	SWITH BUTTON "P" SERIES	01S 4SC0249	A	1	
TM4BLK	TERMINAL BLACK	50C TP4+(BLK)		2	
TM4RED	TERMINAL RED	50C TP4+(RED)		2	
TS4B164	SOLDER TAG 4BA	05R X		4	
WS3M	SPRING WASHER M3	05T WS3M		2	
WS4M	SPRING WASHER M4	05T WS4M		4	
WW25M	WAVEY WASHER M2.5	24L LS508/53		4	
WW3M	WAVEY WASHER M3	24L LS508/54		12	
4NET301BHS	HEATSINK ASSEMBLY		A	1	4
5NE301BR	REGULATOR NON-STANDARD		A	2	5
5SEBR	REGULATOR STANDARD BOARD		A	1	5
BC1384	E30 REGULATOR BOARD	03C N1SAK13840	B	1	B
CR6100NLM	100NF 20% 100V 7.5MM	159W MKS3		1	C105
CX6100NPM	100NF 20% 250V R200	13R PME+271M610M		1	C106
DBB80	BR. RECT. 25MM LDS 125V 5A	11G B80C/5000/3300		1	BR1
DG752	DIODE	02M MR752		1	D101
RM13R90FF	3R90 1% 0W60 100PPM 250V	18P MRS25		4	R102-105
RM210R0FF	10R0 1% 0W60 50PPM 250V	18P MRS25		1	R101
TBM3905PS	STRAIGHT PIN HEADER 5 WAY 3.96	23M 5238-39-28-1055		1	S101
VAOMIT	TRANSISTORS/ICS OMITTED	00F IN+HOUSE+REFERENCE		4	Q102-105

FARNELL PART NUMBER	DESCRIPTION	MANF PART NO	ISS	QTY	CIRCUIT REF
VT3055T	TRANS MJE3055T	02M MJE3055T		1	Q101
CEC470UKM	470UF 20% 63V R075	134N KMVB		4	C101-104
RM43K90FF	3K90 1% 0W60 50PPM 250V	18P MRS25		1	R106
7AE30HS	E30 HEATSINK ASSEMBLY	FI 2DJ10370401	A	2	
7SU3259	HEATSINK PART "A"	K 00F 2SUBA3259	C	1	
7SU3261	HEATSINK PART "C"	K 00F 3SUBA3261	B	1	
7SU3262	HEATSINK PART "D"	K 00F 3SUBA3262	B	1	
7SU3263	HEATSINK PART "E"	00F 4SUBA3263	D	2	
7SU3924	L H HEATSINK E SERIES	00F 3SUBA3924	A	1	
7SU3925	R H HEATSINK E SERIES	00F 3SUBA3925	A	1	
7SU3264	4DA/A #TRANSISTR CLAMP#	00F 4SUDA3264	A	2	
7SU4539	STRAP	00F 4SUDA4539	A	1	
7SU4540	ANGLE SUPPORT	00F 4SUDA4540	A	2	
MB56201	TOP HAT BUSH 6BA	01P 56201J		4	
MF3327	INSULATOR 36 X 25	33P 4SU003327	A	4	
VT3055T	TRANS MJE3055T	02M MJE3055T		8	Q102-05 X2
WW3M	WAVEY WASHER M3	24L LS508/54		20	
HL9X30	BLANK 9X30 P120	51D P120		1	

\*\*\*\*\*

E30-2BT 0-30V 0-2A Twin O/P Bench Power Supply - 17 December 1991

21E302BT	BENCH P/S 0-30V/2A TWIN O/P		A	1	
31ET302B	CASING ET30/2B		A	1	3
FF2A0013	FUSE 2 AMP QUICK BLOW	03B S500		2	F302 X2
FH340RA	FUSE HOLDER 5 X 20MM P/MTG.	12A TO340RA		3	F301 2 +1
FT4A00S503	FUSE 4 AMP ANTI-SURGE	03B S503		1	F301
HA0518	HANDLE L30	89B 3SV000518	C	1	
HM0032	HANDLE COVER L30'S	72H 3SV000032	A	2	
HR0514	L30 HANDLE RET	22P ASUAE0514	A	2	
4NET302BC	CHASSIS ASM ET30/2B		A	1	4
7SU3328	PACKING PIECE	00F 4SUDA3328	A	1	
		62T 16+SWG			
FS9820	FUSE HOLDER SHROUD 5 X 20MM	28B 9820		3	F301 2 +1
GC151	R.H. STRAIN RELIEF BUSH	30H SR-15-1+BLACK		1	
HFSTD	FOOT 103-E119700	37F 103-E1197-00		4	
KP3M10	SCREW M3 X 10 PAN HD POZI	05T KP3M10		4	
NF4M	FULL NUT M4	05T NF4M		4	
SA5000A	TRANSPARENT SWITCH COVER	45L 5000A		1	SW301
SB5040	MAINS SWITCH 4 WAY	45L PBMS5040		1	SW301

FARNELL PART NUMBER	DESCRIPTION	MANF PART NO	ISS	QTY	CIRCUIT REF
SS22105BNM	SEL T22105BAAB UNMARKED	12A T22105BAAB		1	SW302
TBM3902HS	CRIMP HOUSING 2 WAY 3.96MM	23M 3069+09-91-0200		4	S2:201 X2
TBM3905HS	CRIMP HOUSING 5 WAY 3.96MM	23M 3069+09-91-0500		4	S1:101 X2
ZR0332	E30/2B E30/2BT 240V	01B 3SR0332		2	TX301 X2
4NET302BF	FRONT PANEL ET30/2B		A	1	4
5NE301BC	NON-STANDARD CONTROL C.B.		A	2	5
5SEBC	STD. CONT. CB COMPS. E15/E30		C	1	5
BC1387	E30 CONTROL BOARD	03C N1SAK13870	B	1	B
CAOMIT	CAPACITORS OMITTED			4	C3-6
CEC470UIM	470UF 20% 40V R050	134N KMVB		2	C1 2
DG4003	DIODE	11G 1N4003		1	D1
DG4148	DIODE	23N 1N4148		5	D2-6
DZ16V20E	6.2V 5% 0W50	31I ZPD6.2		1	Z1
PAOMIT	POTENTIOMETERS OMITTED	00F PAOMIT		1	P1
RAOMIT	RESISTORS OMITTED	01B RAOMIT		3	R16 9:20
RM11R00FF	1R00 1% 0W60 100PPM 250V	18P MRS25		2	R1 2
RM210R0FF	10R0 1% 0W60 50PPM 250V	18P MRS25		1	R18
RM3470RFF	470R 1% 0W60 50PPM 250V	18P MRS25		1	R15
RM3910RFF	910R 1% 0W60 50PPM 250V	18P MRS25		1	R11
RM41K80FF	1K80 1% 0W60 50PPM 250V	18P MRS25		2	R9:17
RM44K70FF	4K70 1% 0W60 50PPM 250V	18P MRS25		1	R10
RM45K90FF	5K9R 1% 0.6W 50PPM 6.5mm	18V SMA0207S+TK50+5K9+1%		2	R5 6
RM510K0FF	10K0 1% 0W60 50PPM 250V	18P MRS25		1	R12
RM566K5FF	66K5 1% 0W60 50PPM 250V	18P MRS25		2	R7 8
TAOMIT	SOCKETS,PLUGS OMITTED	00F TAOMIT		1	S3
TBM3902PS	STRAIGHT PIN HEADER 2 WAY 3.96	23M 5238-39-28-1025		1	S2
TBM3905PS	STRAIGHT PIN HEADER 5 WAY 3.96	23M 5238-39-28-1055		1	S1
VA358N	IC LM358N NSC ONLY	23N LM358N		1	U1
VA78L12CP	IC MC78L12CP/LM78L12ACZ	23N LM78L12ACZ		1	U2
VS8P	IC SKT 703-1308-010410	28I 703-1308-010410		1	U1
RAOMIT	RESISTORS OMITTED	01B RAOMIT		2	R3 4
RM512K0FF	12K0 1% 0W60 50PPM 250V	18P MRS25		1	R13
RM562K0FF	62K0 1% 0W60 50PPM 250V	18P MRS25		1	R14
5NE301BO	OUTPUT ASSEMBLY		B	2	5
BC1388	E30 OUTPUT BOARD	01K N1PAK13880	B	1	B
CEC470UIM	470UF 20% 40V R050	134N KMVB		1	C201
DG752	DIODE	02M MR752		1	D201
HC10W508	10W FLEXI 0.1 PITCH	01F FST22A10		1	S202
LD134G	LED GRN T1 3/4 MV64530	11Q MV64530+/-MP52+CLIP		1	LD201
LD134R	LED RED T1 3/4 MV5753	11Q MV5753		1	LD202
PM3100RMH	100R 20% PRESET HORZ STURN	02S 67X		1	P201
PW45K00JN	5K00 5% NPREST LIN	02S 534-5K		1	P202

FARNELL PART NUMBER	DESCRIPTION	MANF PART NO	ISS	QTY	CIRCUIT REF
RM3470RFF	470R 1% 0W60 50PPM 250V 18P	MRS25		1	R203
RM41K37FF	1K37 1% 0W60 50PPM 250V 18P	MRS25		1	R201
RM42K70FF	2K70 1% 0W60 50PPM 250V 18P	MRS25		1	R204
RM533K0FF	33K0 1% 0W60 50PPM 250V 18P	MRS25		1	R202
SS20201	S/SW L202-01-1-MS-02-Q	35R L202-01-1-MS-02-Q		1	SW201
TBM3902PS	STRAIGHT PIN HEADER 2 WAY 3.96	23M 5238-39-28-1025		1	S201
WN10M17	NYLON WASHER M10 X 17.45MM O/D	40P 041-3728		1	
7SU3257	METER BRACKET	KA 00F 3SUDA3257	C	2	
EM0021	E30/2 E30/2BT METER	01S 3SMO00021	B	2	M301
HK150	KNOB CAP C150 SIF BLK	01S C150		2	
HK15025	KNOB S150250 SIF BLK	01S S150250		2	
HK151	NUTCOVER N151 SIF BLK	01S N151		2	
KC3M6	SCREW M3 X 6 CSK HD POZI	05T KC3M6		4	
KP3M6	SCREW M3 X 6 PAN HD POZI	05T KP3M6		4	
NF3M	FULL NUT M3	05T NF3M		2	
NR3M10TH	SPACER M3 X 10MM THR'D HEX	01H R6374-02		2	
NR3M18TH	SPACER M3 X 18MM THR'D HEX	01H R6378-02		4	
SA4748BLK	SWITCH BUTTON BLACK	37I 4748		1	
TM4BLK	TERMINAL BLACK	50C TP4+(BLK)		2	
TM4RED	TERMINAL RED	50C TP4+(RED)		2	
TS4B164	SOLDER TAG 4BA	05R X		4	
WS3M	SPRING WASHER M3	05T WS3M		2	
WS4M	SPRING WASHER M4	05T WS4M		4	
WW25M	WAVEY WASHER M2.5	24L LS508/53		4	
WW3M	WAVEY WASHER M3	24L LS508/54		12	
4NET302BHS	HEATSINK ASSEMBLY		A	1	4
5NE302BR	REGULATOR NON-STANDARD		A	2	5
5SE302BR	REGULATOR STANDARD		A	1	5
BC1724	REGULATOR CB E302B	01K BC17240	A	1	B
CAOMIT	CAPACITORS OMITTED			1	C106
CR6100NLM	100NF 20% 100V 7.5MM	159W MKS3		1	C105
DG752	DIODE	02M MR752		1	D101
RAOMIT	RESISTORS OMITTED	01B RAOMIT		4	R102-05
RM210R0FF	10R0 1% 0W60 50PPM 250V 18P	MRS25		1	R101
TBM3905PS	STRAIGHT PIN HEADER 5 WAY 3.96	23M 5238-39-28-1055		1	S101
VAOMIT	TRANSISTORS/ICS OMITTED	00F IN+HOUSE+REFERENCE		4	Q102-05
VT3055T	TRANS MJE3055T	02M MJE3055T		1	Q101
WW3M	WAVEY WASHER M3	24L LS508/54		6	
CEC470UKM	470UF 20% 63V R075	134N KMVB		8	C101-04 07-10
RM43K90FF	3K90 1% 0W60 50PPM 250V 18P	MRS25		1	R106
MB0015B	M3 INSULATING BUSH	72H 4SV00015B	E	16	
MC1	CERAMIC BEAD SMALL	57M IPB/1		16	
MM3055	TRANSISTOR MICA TO3	70H DF377A		8	

FARNELL PART NUMBER	DESCRIPTION	MANF PART NO	ISS	QTY	CIRCUIT REF
NF3M	FULL NUT M3	05T NF3M		8	
NR3M12TH	SPACER M3 X 12MM THR'D HEX	01H R6334-02		8	
NR3M18MF	SPACER M3 X 18MM	33H C022L880018		8	
NR3M25TH	SPACER M3 X 25MM THR'D HEX	01H R100911C		8	
RM11R00FF	1R00 1% 0W60 100PPM 250V	18P MRS25		8	R102-05 X2
VT3055	TRANS 2N3055 TE1912	29S 2N3055		8	Q102-05 X2
WF3M	FLAT WASHER M3	05T WF3M		32	
WS3M	SPRING WASHER M3	05T WS3M		32	
8L0312	PATENT PROTECTION LABEL	00F 4SQ0312	A	1	PI244
99CR	COMPONENTS TO BE SPECIFIED			1	METALWORK
HL9X30	BLANK 9X30 P120	51D P120		1	



INCORPORATING WAYNE KERR INSTRUMENTS