



TrailBlazer 250

OWNERS MANUAL



TWO WAY GMRS RADIO

General Mobile Radio Service



Safety Information

Before operating the radio, please read all safety and operating instructions. Save all instructions in a safe place for future reference.

Warning: Important Safety Information

1. Only accessories included in this package or specified by the manufacturer should be used with the radio. The USB-C charging input is compatible with most high quality USB Type C chargers that fully conform to the USB standards.
2. Do not use cleaners or solvents to clean the exterior of the radio. Use only a damp or dry cloth.
3. Do not attempt to service the receiver yourself. Removing the cover will void the warranty. Changes or modifications not expressly approved by Cobra may void the user's authority granted by the FCC to operate this device and should not be made.
4. Do not plug the wall adaptor into the power outlet if the outlet is wet.
5. Do not use any portable radio that has a damaged antenna. If a damaged antenna comes into contact with your skin, a minor burn can result.

WARNING: Important Safety Instructions for Battery and Chargers

Read All Instructions:

- Do not incinerate the battery even if it is severely damaged or is completely worn out.
- Do not discard the battery in a fire. The battery pack can explode in a fire.
- Do not replace the battery in any area labeled "Hazardous Atmosphere". Any sparks created in a potentially explosive atmosphere can cause an explosion or fire.
- Do not disassemble, crush, puncture, shred, or otherwise attempt to change the form of the battery.
- Do not dry a wet or damp battery with an appliance or heat source, such as a hair dryer or microwave oven.
- A small leakage of liquid from the battery cells may occur under extreme usage or temperature conditions. Do not open, deform or mutilate the battery as there may be corrosive materials which can cause damage to eyes or skin and may be toxic if swallowed.
- Never alter the AC cord or plug provided with the unit. If the plug will not fit in the outlet, have the proper outlet installed by a qualified electrician. An improper installation can result in a risk of electric shock.

However, if the outer seal is broken and this leakage gets on your skin:

- a. Wash quickly with soap and water.
- b. Neutralize with a mild acid such as lemon juice or vinegar.
- c. If battery liquid gets into your eyes, flush them with clean water for a minimum of 10 minutes and seek immediate medical attention.

Recycle Battery

Local, state or federal laws may prohibit disposal of batteries in ordinary trash. Consult your local waste authority for information regarding available recycling and/or disposal options.



Contents

SAFETY INFORMATION	A1
INTRODUCTION.....	3
PRODUCT FEATURES	4
INSTALLATION	6
-Installing and Charging Batteries	6
-Quick Start	6
OPERATION	7
-Turning the Radio On and Off	7
-Battery Low.....	7
-Communicating with Another Radio	7
-Changing Channels.....	7
-Monitor.....	7
-Call Button	8
-Lock Function	8
-Channel Banks.....	8
-Find Function	8
-Weather (WX)	9
-NOAA Emergency Weather Alert	9
-Emergency Alert.....	9
-Flashlight & Flashlight S.O.S.....	10
-Menu	10
-Menu/Power Button.....	11
-Privacy Codes (CTCSS & DCS)	12
-CTCSS Privacy Code & Set DCS Privacy Code	12
-Voice Activated Transmit (VOX) On/Off & VOX Sensitivity	12
-Repeaters On/Off.....	12
-Call Tones 1-10	12
-Roger Beep On/Off	12
-Key Tones On/Off.....	12
CHANNEL FREQUENCIES.....	13
-Bank 1	13
-Bank 2	14
-Bank 3.....	15
-Bank 4.....	16
-Weather Channels.....	16
-CTCSS Codes.....	16
-DCS Codes	17
FREQUENTLY ASKED QUESTIONS	18
SOFTWARE, FCC AND SAFETY STATEMENT.....	19
LIMITED 1-YEAR WARRANTY AND TRADEMARK INFORMATION.....	21



Introduction

Prepare for your next adventure into the wild unknown with TrailBlazer radios—perfect for communication during a day on the dunes, an afternoon rock-crawling, or a week overlanding. With higher power and superior range, GMRS technology empowers those who enjoy the outdoors.

In this user's guide, you should find all the information you need to operate your TrailBlazer 250 radio. If you require further assistance after reading this guide, Cobra offers the following customer assistance services:

For Assistance In The U.S.A.

For any questions about operating this new Cobra product, PLEASE CONTACT COBRA FIRST. The contact information for Cobra will vary depending on the country in which you purchased and uses the product. For the latest contact information, please go to www.cobra.com/support or call 1-800-543-1608.

If your product should require factory service, please go to www.cobra.com/support and follow the instructions.

Operational Cautions

Exposure to high volume sound levels may cause temporary or permanent damage to your hearing. Although there is no single volume setting that is appropriate for everyone, you should always use your radio with the volume set at low level and avoid prolonged exposure to high volume sound levels.

1. Set the volume control in a low position and use as low a volume as possible.
2. Avoid turning up the volume to block out noisy surroundings. Whenever possible, use your radio in a quiet environment with low background noise.
3. Limit the amount of time you use headsets or earpieces at high volume levels.
4. When using the radio without a headset or earpiece, do not place the radio's speaker directly against your ear.
5. Observe all signs and instructions that require an electrical device or RF radio product to be switched off in designated areas, such as gas/refueling stations, hospitals, blasting areas, potentially explosive atmospheres, or aircraft.
6. If you experience a skin irritation after using this product, discontinue use and seek medical attention.
7. If the product or charger: overheats; has a damaged cord or plug; has been dropped or damaged; has been dropped into water, disconnect any charger from its power supply, discontinue use of the product.

Electromagnetic Interference

Nearly every electronic device is susceptible to electromagnetic interference (EMI).

- When instructed to do so, turn off your radios when on board an aircraft. Any use of a RF device must be in accordance with applicable laws, regulations, and airline crew instructions.
- Some radios may interfere with some hearing aids. In the event of such interference, you may want to consult your hearing aid manufacturer or physician to discuss alternatives.



PRODUCT FEATURES



- | | |
|------------------------|---------------|
| 1. PTT Button | 5. USB-C Port |
| 2. Emergency Button | 6. Microphone |
| 3. Power & Volume Knob | 7. Speaker |
| 4. Headset Jack | 8. Flashlight |



Introduction

TrailBlazer 250 Keypad



Letter Label	Button	Press	Press and Hold
A.	MENU	Menu	N/A
B.	UP	Channel Up	Fast Channel Up
C.	FIND	FIND	Scan
D.	BANK	Bank	Weather
E.	DOWN	Channel Down	Monitor
F.	CALL	Call	Key Lock

TrailBlazer 250 Backlit LCD Display

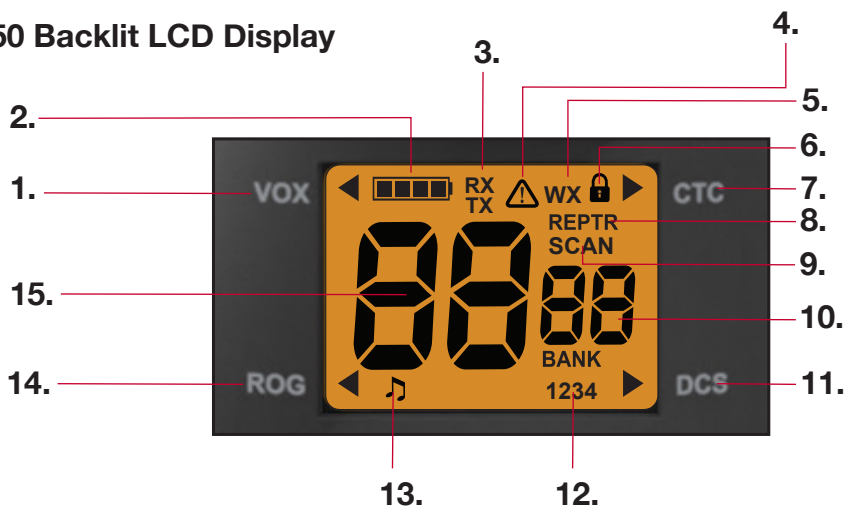

- | | | |
|----------------------------|-----------------------|----------------------|
| 1. VOX | 6. Keypad Lock | 11. DCS Privacy Code |
| 2. 4-Segment Battery Level | 7. CTCSS Privacy Code | 12. Bank 1-4 |
| 3. Receive / Transmit | 8. Repeater | 13. Key Tones |
| 4. Weather Alert | 9. Scan | 14. Roger Beep |
| 5. Weather | 10. Privacy Code | 15. Channel |



Installation

Installing and Charging Batteries

1. Insert the included rechargeable Nickel Metal Hydride (NiMH) batteries into the radio. Check to see that the batteries have been inserted properly.
2. To charge the batteries in the radio insert the USB cable into the charge jack located at the right side of the radio.
3. Plug the cable into a USB-compatible power port.
4. The radio will display a flashing battery icon while charging.

NOTES:

- Cobra recommends your radio is turned off while being charged.
- Please charge new batteries for 14 hours for first time of use.
- Only charge NiMH batteries in the radio. If higher capacity batteries are used it will take longer to charge.
- For best performance use a dedicated battery charger to charge your AA rechargeable batteries.
- Non-Rechargeable alkaline, non-rechargeable Lithium primary, and rechargeable Lithium Ion batteries can also be used, but cannot be charged inside the radio.

WARNING: Do not attempt to charge alkaline batteries or Lithium primary batteries. Do not mix old and new batteries or battery types in the radio (alkaline, rechargeable (NiCD, NiMH, Li-Ion, etc.)

Quick Start

1. Turn ON/OFF/Volume Knob clockwise to turn the radio on and counter clockwise to turn the radio off.
2. Select a desired channel.

NOTE: Both radios must be tuned to the same channel/privacy code to communicate.

3. Push and hold the Push-To-Talk (PTT) button while speaking into the microphone.
4. When finished talking, release the PTT and listen for a response.

To restore the radio to default settings:

1. Power off the radio
2. Simultaneously hold the MENU and DOWN buttons and power on the radio

This will reset all radio settings and channel banks to their factory defaults.



Turning the Radio On and Off

- To power ON turn Power Knob clockwise
- To power OFF turn Power Knob counter-clockwise

Battery Low

When battery power is low, the final bar in the Battery icon will blink and an audible tone will sound twice indicating that the batteries are low. Insert new batteries into the radio or recharge the batteries in the radio if rechargeable batteries are being used.

Communicating with Another Radio

1. Press and hold the Push-To-Talk (PTT) button on the side of the radio
2. With the microphone about two inches (5 cm) from your mouth, speak in a normal voice.
3. Release the PTT button when you are finished talking and listen for a response.

You cannot receive incoming calls while pressing the PTT button.

Both radios need to be on the same frequency and privacy code to communicate.

- Turn the power/volume knob clockwise to increase the volume.
- Turn the power/volume knob counter clockwise to decrease the volume.

Tip: It is recommended to wait a short time after pressing the PTT before speaking to avoid cutting off the beginning of the message.

Changing Channels

To change the channel, press the up or down button until you reach your desired channel.

Monitor

Your TrailBlazer 250 has an automatic squelch function to automatically block weak transmissions and static, interference, or other unwanted noise.

You can turn on the Monitor function to turn off the automatic squelch, allowing all signals to be received. This is also an effective way to hear audio from the radio speaker in order to adjust the volume.

- Press and hold the Monitor button for 2 seconds to turn the monitor on to open the squelch and allow all signals and noise to be received. Adjust the volume and listen for any weak signals. The monitor will turn off when the button is released.
- Press and hold the Monitor button for 5 seconds to continuously monitor a selected channel. The squelch will open allowing all signals and noise to be received. To turn off monitor and return to automatic squelch press and hold the monitor button.

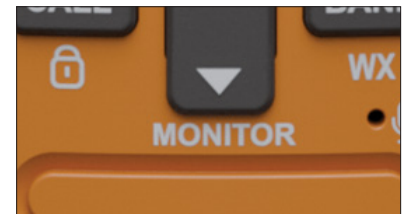

Set the volume control in a low position and use as low a volume as possible. Do not hold the radio speaker close to your ear. If the volume is set to a high level, it could damage your hearing.



Call button

Press and release the Call button to alert others that you are calling. The other person will hear a two second call tone. This tone is only used to alert others of incoming voice communications.

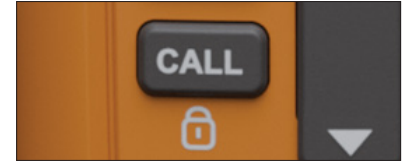

Lock Function

The lock function locks the radio controls to prevent accidental operation.

Channel Banks

The TrailBlazer 250 comes equipped with multiple channel banks to provide compatibility with Cobra Family Radio Service (FRS) radios. If repeaters are turned on an additional 8 repeater channels 15RP-22RP are available. By default the channel banks are:

1. **Bank 1:** 22 GMRS/FRS channels +8 GMRS repeater channels.
2. **Bank 2:** 60 GMRS/FRS channels compatible with Cobra RX series FRS radios and Midland 50 channel FRS and GMRS radios.
 - a. Channels 1-22 (and +8 repeater channels if turned on) are the standard GMRS/FRS channels
 - b. Channels 23-60 have preset privacy codes
3. **Bank 3:** 22 GMRS/FRS channels with preset privacy codes. Compatible with Cobra PX series FRS radios.
4. **Bank 4:** Blank by default. Bank 4 is used for the Frequency Find function. When channels are found with the find function they will be stored in bank 4.

In addition to setting privacy codes, channel banks can be further customized with the Cobra Programming Software (CPS). The Cobra Programming Software allows you to enable or disable channels to customize the channel banks. Instead of a 22 or larger channel bank a radio can be programmed on only have 1 or 2 channels. The CPS also allows for changing the radio settings and adjusting all of the channels in a easy and convenient user interface.

Find Function

The Find function allows your TrailBlazer 250 to scan the entire frequency band and lock onto the strongest nearby signal. This is a convenient way to:

- Locate the transmissions from any nearby GMRS or FRS radios
- Identify what channel a radio is transmitting on if it does not have a display
- Connect multiple radios to the same channel and privacy code

Press the Find button to initiate a signal find. The radio will flash the channel indicator. If a strong signal is found the radio will lock onto the signal and show the channel and privacy code. The TrailBlazer radio will be on Bank 4 with this channel information and you can now receive and transmit to other radios on that channel.

The TrailBlazer 250 can also perform a standard channel scan of all of the channels in the selected channel bank. Press and hold the Find button to initiate a channel scan. The radio will advance through each of the channels in the selected channel bank and stop if a strong signal is found. To continue the scan press the up or down buttons. To stop the scan and communicate on the selected channel press the PTT button.



Weather (WX)

The TrailBlazer 250 has 10 NOAA weather channels and a weather alert feature. The National Oceanic and Atmospheric Administration (NOAA) provides continuous around-the-clock broadcasts of the latest weather conditions. Recorded weather messages run every 4-6 minutes and are revised every 2-3 hours as needed.

NOAA Emergency Weather Alert

In the event of a major storm or other weather condition, NOAA broadcasts a 1050 Hz tone that your radio can detect and warn you of a weather alert condition. When the Weather Alert mode on your radio is set to On, this signal will produce a loud tone from the radio speaker and will automatically switch to the alerting weather channel so the alert broadcast can be heard.

NOTE: Typically only one or two weather channels will be operating in a given location. Select the channel with the strongest signal for your location. This weather channel will also be used to for detecting a emergency weather alert.

To test this system, NOAA broadcasts the 1050 Hz signal every Wednesday sometime between 10am and noon in each local time zone. Any receiver that can detect the weather alert tone may use this service to verify that this system is functioning properly.

To enter the WX mode press and hold the WX key. The weather channel will be shown on the display.

To set WX Alert to On or Off press and release the Menu key while in WX mode. Use the up and down keys to select WX Alert On or Off. Press PTT or wait 6 seconds to confirm and exit the menu

Emergency Alert

The Emergency Alert feature can be used to signal members in your group of your need for urgent help. The TrailBlazer series radios will operate in an automatic hands-free emergency mode.

All Cobra RX380, RX680, PX650, & CXY900 series FRS radios and TrailBlazer 250, 450, & 500 series GMRS radios are compatible with the Emergency Alert Feature.

Radios other than these Cobra series radios can receive the emergency alert signal, but may not respond to the emergency alert in the same way as a compatible Cobra series radio.

To signal an Emergency Alert press and hold the Emergency Alert button for 3 seconds

- The backlight will flash and an alert tone will sound.
- After the alert tone ends you may speak into the microphone to make a transmission.
 - You do not need to continue to hold the emergency alert button and do not need to press and hold the PTT button for your message to be transmitted.
 - This hands-free emergency alert transmission mode will last for 22 seconds.
- After a total of 30 seconds your radio will sound a beep tone and the backlight will stop flashing. Your radio will return to its normal two-way radio function.
- Turning off the radio will cancel the Emergency Alert.

NOTE: In order to receive an emergency alert a receiving radio(s) must be set to the same channel and privacy code.

Emergency Alert continued



Operation

A compatible Cobra radio receiving an emergency alert will respond by:

- Sounding an 8 second alert tone at maximum volume.
- After 8 seconds the radio buttons and controls will be locked so the incoming emergency message can be received
- After a total of 30 seconds your radio will sound a beep tone and your radio will return to its normal two-way radio function.

WARNING: The Emergency Alert feature should only be used in the event of an actual emergency. Cobra is not responsible if there is no response to the emergency alert from the receiving group.

Flashlight & Flashlight SOS

Press and release the Flashlight button to use the LED flashlight located at the bottom of the radio. To activate the S.O.S. function, press and hold the Flashlight button. Press and release to turn off the flashlight or S.O.S. function.

Menu

By scrolling through the Menu, you will be able to select or turn on preferred features of your TrailBlazer 250. When scrolling through the Menu, the radio features will be displayed in the same predetermined order:

- **Set CTCSS Privacy Code**
- **Set DCS Privacy Code**
- **Set Vox On/Off**
- **Set Vox Sensitivity**
- **Set Repeaters On/Off**
- **Set Call Tones 1-10**
- **Set Roger Beep On/Off**
- **Set Key Tones On/Off**

NOTE: Split tones can be set for the repeater channels where a different privacy code is used for Transmit and Receive. These can even be set to use CTCSS for one code and DCS for the other.



Menu/Power Button

Each press of the Menu button advances you to the next option setting. Press the UP or DOWN buttons to change the setting, you may also press the **PTT** button to save the new setting and return to **standby** mode.

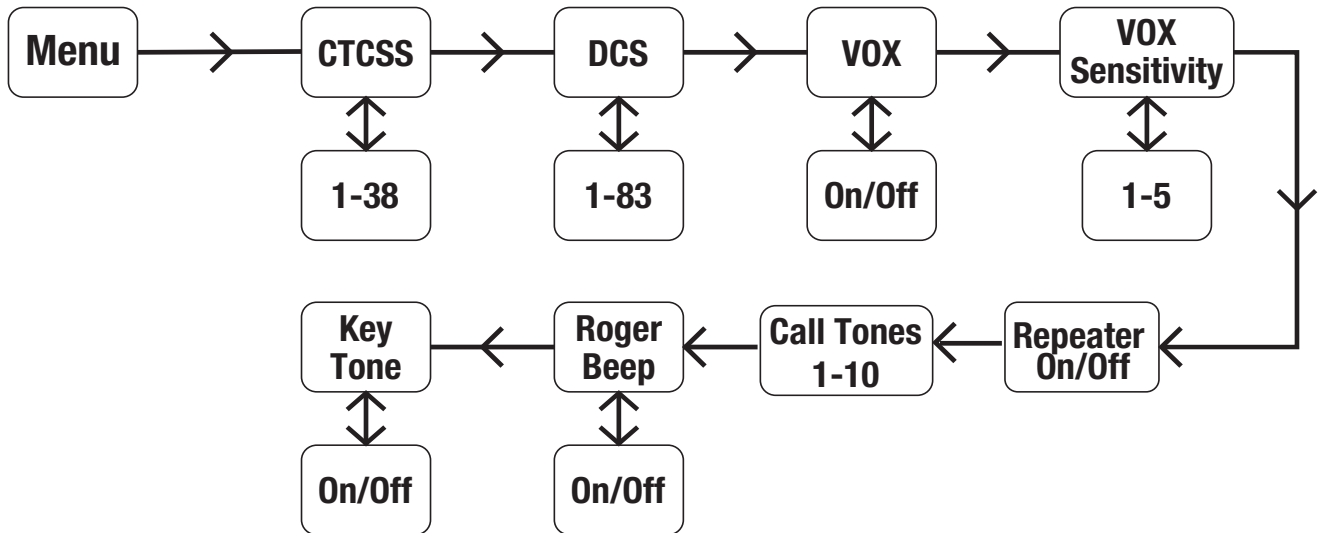

When changing a setting in the menu, select the desired setting and choose one of the following:

- Press the Menu button to save the new setting and proceed to other menu settings.
- Press the Push-to-Talk button to save the new setting and return to Standby mode.
- Do not press any buttons for 6 seconds to save the new setting and return to Standby mode.

To restore the radio to default settings:

- Power off the radio
- Simultaneously hold the MENU and DOWN buttons and power on the radio

This will reset all radio settings and channel banks to their factory defaults.



Privacy Codes (CTCSS & DCS)

Your TrailBlazer 250 radio incorporates two advanced coded squelch systems that can help to reduce interference from other users on any given channel.

CTCSS (Continuous Tone Coded Squelch System) provides 38 privacy codes and DCS (Digitally Coded Squelch) provides 83 privacy codes. Either system can be used on channels 1-22, but only one system can be used on a channel at a given time.

NOTE: To successfully communicate using a privacy code, both the sending and receiving radios must be tuned to the same channel and to the same privacy code system (CTCSS or DCS) and privacy code number. Each channel will remember the last privacy code system and number you select.

NOTE: The privacy code 00 is not a privacy code, but allows all signals to be heard on a channel that is set to 00 on both the CTCSS and DCS systems.

CTCSS Privacy Code & Set DCS Privacy Code

Press the Up or Down button to select a privacy code. You can hold the Up or Down button for fast advance. The privacy code 0 turns the privacy code off and allows all signals to be heard on a channel. When setting the privacy codes for a repeater channel separate selections can be made for the Transmit Privacy Code and the Receive Privacy Code. These can even have one privacy code using CTCSS and the other using DSC.

Voice Activated Transmit (VOX)

VOX enables hands-free operation of your radio by automatically transmitting when you speak. This feature is particularly effective when used with a headset or lapel speaker/microphone.

VOX Sensitivity Settings

Adjust VOX sensitivity (levels 1-5) to match your voice volume and minimize unwanted transmissions from background noise. Level 1 requires the loudest voice input and is the most resistant to background noise. Level 5 is the highest sensitivity and activates with minimal voice input. For optimal performance, it is recommended to use a compatible speaker/microphone accessory with the VOX feature.

Repeaters On/Off

Turning repeaters On will add the 8 repeater channels 15RP-22RP to the channel list on Banks 1, 2, & 3.

Call Tones 1-10

The current Call Tone is sounded from the radio. Press the up and down buttons to scroll through the ten available call tones (1-10)

Roger Beep On/Off

A receiving radio will hear an audible tone when you release the Talk button. This alerts the other party that you are finished talking and it is OK for them to speak.

The roger beep will also sound from your radio as an indication that roger beep is on.

Key Tones On/Off

When Key Tones are On the radio will give a confirmation beep when buttons are pressed.



Channel Frequencies - Bank 1*

Index	Radio Channel	Frequency	Bandwidth
1	1	1 - 462.5625	Wideband / Narrowband
2	2	2 - 462.5875	Wideband / Narrowband
3	3	3 - 462.6125	Wideband / Narrowband
4	4	4 - 462.6375	Wideband / Narrowband
5	5	5 - 462.6625	Wideband / Narrowband
6	6	6 - 462.6875	Wideband / Narrowband
7	7	7 - 462.7125	Wideband / Narrowband
8	8	8 - 467.5625	Narrowband
9	9	9 - 467.5875	Narrowband
10	10	10 - 467.6125	Narrowband
11	11	11 - 467.6375	Narrowband
12	12	12 - 467.6625	Narrowband
13	13	13 - 467.6875	Narrowband
14	14	14 - 467.7125	Narrowband
15	15	15 - 462.55	Wideband / Narrowband
16	16	16 - 462.575	Wideband / Narrowband
17	17	17 - 462.6	Wideband / Narrowband
18	18	18 - 462.625	Wideband / Narrowband
19	19	19 - 462.65	Wideband / Narrowband
20	20	20 - 462.675	Wideband / Narrowband
21	21	21 - 462.7	Wideband / Narrowband
22	22	22 - 462.725	Wideband / Narrowband
23	15RP	15RP - 467.55	Wideband / Narrowband
24	16RP	16RP - 467.575	Wideband / Narrowband
25	17RP	17RP - 467.6	Wideband / Narrowband
26	18RP	18RP - 467.625	Wideband / Narrowband
27	19RP	19RP - 467.65	Wideband / Narrowband
28	20RP	20RP - 467.675	Wideband / Narrowband
29	21RP	21RP - 467.7	Wideband / Narrowband
30	22RP	22RP - 467.725	Wideband / Narrowband

* Wideband is the default



Channel Frequencies - Bank 2

Index	Radio Channel	Frequency	Code Type	Code Value	Index	Radio Channel	Frequency	Code Type	Code Value
1	1	1 - 462.5625			35	27 (Channel - 15)	15 - 462.55	CTCSS	26 - 162.2
2	2	2 - 462.5875			36	28 (Channel - 17)	17 - 462.6	CTCSS	23 - 146.2
3	3	3 - 462.6125			37	29 (Channel - 19)	19 - 462.65	CTCSS	20 - 131.8
4	4	4 - 462.6375			38	30 (Channel - 21)	21 - 462.7	CTCSS	17 - 118.8
5	5	5 - 462.6625			39	31 (Channel - 2)	2 - 462.5875	DCS	1 - 23
6	6	6 - 462.6875			40	32 (Channel - 4)	4 - 462.6375	DCS	4 - 31
7	7	7 - 462.7125			41	33 (Channel - 6)	6 - 462.6875	DCS	7 - 47
8	8	8 - 467.5625			42	34 (Channel - 8)	8 - 467.5625	DCS	10 - 65
9	9	9 - 467.5875			43	35 (Channel - 10)	10 - 467.6125	DCS	13 - 73
10	10	10 - 467.6125			44	36 (Channel - 12)	12 - 467.6625	DCS	16 - 115
11	11	11 - 467.6375			45	37 (Channel - 14)	14 - 467.7125	DCS	19 - 131
12	12	12 - 467.6625			46	38 (Channel - 16)	16 - 462.575	DCS	22 - 143
13	13	13 - 467.6875			47	39 (Channel - 18)	18 - 462.625	DCS	25 - 156
14	14	14 - 467.7125			48	40 (Channel - 20)	20 - 462.675	DCS	28 - 172
15	15	15 - 462.55			49	41 (Channel - 22)	22 - 462.725	DCS	31 - 223
16	16	16 - 462.575			50	42 (Channel - 1)	1 - 462.5625	CTCSS	14 - 107.2
17	17	17 - 462.6			51	43 (Channel - 3)	3 - 462.6125	CTCSS	11 - 97.4
18	18	18 - 462.625			52	44 (Channel - 5)	5 - 462.6625	CTCSS	8 - 88.5
19	19	19 - 462.65			53	45 (Channel - 7)	7 - 462.7125	CTCSS	5 - 79.7
20	20	20 - 462.675			54	46 (Channel - 15)	15 - 462.55	CTCSS	2 - 71.9
21	21	21 - 462.7			55	47 (Channel - 17)	17 - 462.6	CTCSS	37 - 241.8
22	22	22 - 462.725			56	48 (Channel - 19)	19 - 462.65	CTCSS	34 - 218.1
23	15RP	15RP - 467.55			57	49 (Channel - 21)	21 - 462.7	CTCSS	31 - 192.8
24	16RP	16RP - 467.575			58	50 (Channel - 2)	2 - 462.5875	DCS	2 - 25
25	17RP	17RP - 467.6			59	51 (Channel - 4)	4 - 462.6375	DCS	5 - 32
26	18RP	18RP - 467.625			60	52 (Channel - 6)	6 - 462.6875	DCS	8 - 51
27	19RP	19RP - 467.65			61	53 (Channel - 8)	8 - 467.5625	DCS	11 - 71
28	20RP	20RP - 467.675			62	54 (Channel - 10)	10 - 467.6125	DCS	14 - 74
29	21RP	21RP - 467.7			63	55 (Channel - 12)	12 - 467.6625	DCS	17 - 116
30	22RP	22RP - 467.725			64	56 (Channel - 14)	14 - 467.7125	DCS	20 - 132
31	23 (Channel - 1)	1 - 462.5625	CTCSS	38 - 250.3	65	57 (Channel - 16)	16 - 462.575	DCS	23 - 152
32	24 (Channel - 3)	3 - 462.6125	CTCSS	35 - 225.7	66	58 (Channel - 18)	18 - 462.625	DCS	26 - 162
33	25 (Channel - 5)	5 - 462.6625	CTCSS	32 - 203.5	67	59 (Channel - 20)	20 - 462.675	DCS	29 - 174
34	26 (Channel - 7)	7 - 462.7125	CTCSS	29 - 179.9	68	60 (Channel - 22)	22 - 462.725	DCS	32 - 226



Channel Frequencies - Bank 3

Index	Radio Channel	Frequency	Code Type	Code Value
1	1	1 - 462.5625	CTCSS	1 - 67
2	2	2 - 462.5875	CTCSS	11 - 97.4
3	3	3 - 462.6125	CTCSS	22 - 141.3
4	4	4 - 462.6375	CTCSS	33 - 210.7
5	5	5 - 462.6625	DCS	1 - 23
6	6	6 - 462.6875	DCS	11 - 71
7	7	7 - 462.7125	DCS	22 - 143
8	8	8 - 467.5625	DCS	33 - 243
9	9	9 - 467.5875	DCS	44 - 331
10	10	10 - 467.6125	DCS	55 - 431
11	11	11 - 467.6375	DCS	66 - 565
12	12	12 - 467.6625	DCS	77 - 712
13	13	13 - 467.6875	CTCSS	1 - 67
14	14	14 - 467.7125	CTCSS	11 - 97.4
15	15	15 - 462.55	CTCSS	22 - 141.3
16	16	16 - 462.575	CTCSS	33 - 210.7
17	17	17 - 462.6	DCS	1 - 23
18	18	18 - 462.625	DCS	11 - 71
19	19	19 - 462.65	DCS	22 - 143
20	20	20 - 462.675	DCS	33 - 243
21	21	21 - 462.7	DCS	44 - 331
22	22	22 - 462.725	DCS	55 - 431
23	15RP	15RP - 467.55		
24	16RP	16RP - 467.575		
25	17RP	17RP - 467.6		
26	18RP	18RP - 467.625		
27	19RP	19RP - 467.65		
28	20RP	20RP - 467.675		
29	21RP	21RP - 467.7		
30	22RP	22RP - 467.725		



Channel Frequencies - Bank 4

Index	Radio Channel	Frequency	Code Type	Code Value
-------	---------------	-----------	-----------	------------

Bank 4 is blank by default. Bank 4 is used for the Find function. As the Find function is used Bank 4 will populate with channels.

Weather Channels

WX Channel	Frequency	WX Channel	Frequency
Channel 1	162.550 MHz	Channel 6	162.500 MHz
Channel 2	162.400 MHz	Channel 7	162.525 MHz
Channel 3	162.475 MHz	Channel 8	161.650 MHz
Channel 4	162.425 MHz	Channel 9	161.775 MHz
Channel 5	162.450 MHz	Channel 10	163.275 MHz

CTCSS Codes

Code	Tone Code
1	67
2	71.9
3	74.4
4	77
5	79.7
6	82.5
7	85.4
8	88.5
9	91.5
10	94.8
11	97.4
12	100
13	103.5
14	107.2
15	110.9
16	114.8
17	118.8
18	123
19	127.3

Code	Tone Code
20	131.8
21	136.5
22	141.3
23	146.2
24	151.4
25	156.7
26	162.2
27	167.9
28	173.8
29	179.9
30	186.2
31	192.8
32	203.5
33	210.7
34	218.1
35	225.7
36	233.6
37	241.8
38	250.3



DCS Codes

Code	Octal	Code	Octal	Code	Octal	Code	Octal	Code	Octal
1	023	21	134	41	306	61	503	81	734
2	025	22	143	42	311	62	506	82	743
3	026	23	152	43	315	63	516	83	754
4	031	24	155	44	331	64	532		
5	032	25	56	45	343	65	546		
6	043	26	162	46	346	66	565		
7	047	27	165	47	351	67	606		
8	051	28	172	48	364	68	612		
9	054	29	174	49	365	69	624		
10	065	30	205	50	371	70	627		
11	071	31	223	51	411	71	631		
12	072	32	226	52	412	72	632		
13	073	33	243	53	413	73	654		
14	074	34	244	54	423	74	662		
15	114	35	245	55	431	75	664		
16	115	36	251	56	432	76	703		
17	116	37	261	57	445	77	712		
18	125	38	263	58	464	78	723		
19	131	39	265	59	465	79	731		
20	132	40	271	60	466	80	732		

NOTE: CTCSS & DCS code numbers may vary across radio brands. These 38 Cobra CTCSS codes and 83 DCS codes are shared across all Cobra FRS and GRMS radios and also used by most radios from Midland, Motorola, Uniden, Backcountry Access, and Rocky Talkie.



Frequently Asked Questions

Power Cycling

As a general troubleshooting step power cycle the radio (turn radio off and back on) to see if the issue persists.

Radio does not turn on

Make sure that the battery(ies) is(are) correctly installed in the radio

Is the battery charged? Replace the battery with a fully charged battery or charge the battery

Radio does not charge

For radios with a desktop charger ensure that the radio is fully seated in the charger

Check the charger and cable to ensure that they are fully connected. If possible try charging another device with the same charger and cable.

No Audio

Check to make sure both the channel and the privacy code match on the transmitting radio and receiving radio(s). If one radio can receive a transmission but the other can not the most likely cause is a mismatch of a privacy code.

Check the volume level of the receiving radio(s).

If an accessory headset or speaker/mic is used ensure that it is fully connected into the radio jack.

Check to ensure that the antenna is properly installed on radio. Inspect the antenna for any signs of damage. If any damage is found the antenna will need to be replaced



Software, FCC and Safety Statement

Cobra Radio Programming Software

Please visit Cobra.com to download the software allowing the ability to fully customize your radio and save Profiles to be used on your radios.

A radio programming cable is required (sold separately).

Transmit and Receive Procedure

Your two-way radio contains a low power transmitter. When the talk button is pushed it sends out radio frequency signals (RF). In 1996 the Federal Communications Commission (FCC) adopted RF exposure guidelines with safety levels for handheld wireless devices. To control your exposure and ensure compliance with the occupational/controlled environment exposure limits, always adhere to the following procedures:

- Transmit no more than 50% of the time.
- To transmit (talk), press the Push to Talk (PTT) button.
- To receive calls, release the PTT button.

Transmitting 50% of the time, or less, is important because the radio generates measurable RF energy exposure only when transmitting (in terms of measuring standards compliance).

FCC Statement

IMPORTANT NOTICE: WARNING: Changes or modifications to this unit not expressly approved by the party responsible for compliance could void the user's authority to operate the equipment. This device complies with parts 15 and 90 of the FCC Rules. Operation is subject to the following two conditions: 1) This device may not cause harmful interference, and 2) this device must accept any interference received, including interference that may cause undesired operation. **NOTE:** This equipment has been tested and found to comply with the limits for a Class B digital device, pursuant to Part 15 of the FCC Rules.

These limits are designed to provide reasonable protection against harmful interference in a residential installation. This equipment generates, uses and can radiate radio frequency energy and, if not installed and used in accordance with the instructions, may cause harmful interference to radio communications. However, there is no guarantee that interference will not occur in a particular installation. If this equipment does cause harmful interference to radio or television reception, which can be determined by turning the equipment off and on, the user is encouraged to try to correct the interference by one or more of the following measures:

- Reorient or relocate the receiving antenna.
- Increase the separation between the equipment and receiver.
- Connect the equipment into an outlet on a circuit different from that to which the receiver is connected.
- Consult the dealer or an experienced radio/TV technician for help.

Disposal of Electroic Equipment This product may contain hazardous substances that could impact health and the environment if not disposed of properly.

The product should not be disposed of along with household waste. It should be handed over to an applicable collection point for the recycling of electrical equipment. By ensuring that this product is disposed of correctly you will help/prevent potential negative impact on the environment.

If you need more information on the collection, reuse and recycling systems, please contact your local civic office or the shop where it was originally purchased.



Software, FCC and Safety Statement

Important FCC RF Exposure Requirements:

For body-worn operation, this radio has been tested and meets the FCC RF exposure guidelines when used with Cobra accessories supplied or designated for this product. Use of other accessories may not ensure compliance with FCC RF exposure guidelines. Use only the supplied antenna. Unauthorized antennas, modifications or attachments could damage the transmitter and may violate FCC regulations. Normal Position: Hold the transmitter approximately two (2) inches from your face and speak in a normal voice, with the antenna pointed up and away. DO NOT hold the antenna when the radio is “in use”. Holding the antenna affects the effective range. Do not hold the antenna when the radio is in use. Holding the antenna affects the effective range.

FCC Part 15.21 Warning Statement

NOTE: THE GRANTEE IS NOT RESPONSIBLE FOR ANY CHANGES OR MODIFICATIONS NOT EXPRESSLY APPROVED BY THE PARTY RESPONSIBLE FOR COMPLIANCE. SUCH MODIFICATIONS COULD VOID THE USER’S AUTHORITY TO OPERATE THE EQUIPMENT.

Radiation Exposure Statement:

Under ISED regulations, this radio transmitter may only operate using the antenna that is affixed to the radio transmitter. Use only the supplied antenna. Unauthorized antennas, modifications, or attachments could damage the transmitter and may void the user’s authority to operate the radio. Any changes of modifications not expressly approved by the party responsible for compliance could void the user’s ability to operate the equipment. SAR tests are conducted using standard operating positions accepted by the FCC/ISED with the device transmitting at its highest certified power level in all tested frequency bands. Although the SAR is determined at the highest certified power level, the actual SAR level of the device while operating can be well below the maximum value. This device has been tested and certified to not exceed the exposure limit established by the FCC/ISED. Tests for each device are performed in positions and locations (e.g. at the ear and worn on the body) as required by the FCC/ISED. For body worn operation, this device has been tested and meets the FCC/ISED RF exposure guidelines when used with an accessory designated for this product or when used with an accessory that contains no metal and that positions the handset a minimum of 10mm from the body. Non-compliance with the above restrictions may result in a violation of RF exposure guidelines.

Licensing

The radios operate on GMRS (General Mobile Radio Service) frequencies which require an FCC (Federal Communications Commission) license. You must be licensed prior to operating the radio. Serious penalties could result from unlicensed use of GMRS channels in violation of FCC rules, as stipulated in the Communications Act Sections 501 and 502 (amended).

You will be issued a call sign by the FCC which should be used for station identification when operating the radio on GMRS channels. You must also cooperate by engaging in permissible transmissions only, avoiding channel interference with other GMRS users, and being prudent with the length of your transmission time.

Apply for a license at the FCC’s website:

<http://www.fcc.gov/universal-license-system>

Contact the FCC at 1-888-CALL-FCC (1-888-225-5322) if you have any questions.

NOTE: Use of this radio outside the country where it was intended to be distributed is subject to government regulations and may be prohibited.



Limited 1-Year Warranty and Trademark Information

Warranty Terms:

Cobra warrants your product against all defects in materials and workmanship for a period of one (1) year from the date of original purchase.

Cobra, at our sole discretion, will repair or replace your product (with the same or comparable product) free of charge.

Cobra will not pay shipping charges that you incur for sending your product to us. Products received COD will be refused.

To make a warranty claim, we will require proof of purchase in the form of an invoice or receipt. No proof of purchase is required for factory direct purchases.

Warranty Exclusions: Warranty does not apply to your product under any of the following conditions: 1. The serial number has been removed or modified. 2. Your product has been subjected to misuse or damage (including water damage, physical abuse, and/or improper installation). 3. Your product has been modified in any way. 4. Your receipt or proof-of-purchase is from a non-authorized dealer or internet auction site including E-bay, U-bid, or other non-authorized resellers.

LIMITATION OF WARRANTY: EXCEPT AS EXPRESSLY PROVIDED HEREIN, YOU ARE ACQUIRING THE PRODUCT “AS IS” AND “WHERE IS”, WITHOUT REPRESENTATION OR WARRANTY. COBRA SPECIFICALLY DISCLAIMS ANY REPRESENTATION OR WARRANTY INCLUDING, BUT NOT LIMITED TO THOSE CONCERNING THE MERCHANTABILITY AND SUITABILITY OF THE PRODUCT FOR A PARTICULAR PURPOSE. COBRA SHALL NOT BE LIABLE FOR CONSEQUENTIAL, SPECIAL OR INCIDENTAL DAMAGES INCLUDING, WITHOUT LIMITATION, DAMAGES ARISING OUT OF THE USE, MISUSE OR MOUNTING OF THE PRODUCT.

The above limitations or exclusions shall be limited to the extent they violate the laws of any particular state. Cobra is not responsible for products lost in shipment between the owner and our service center.

General Warranty Information

Each product we manufacture is covered by our factory warranty. While each product may have unique components and policy, the general guideline below will apply to most Cobra products.

All Cobra products purchased factory-direct or from our Authorized Resellers will come with a two (2) year warranty from the date of the original retail purchase (see policy statement above for full warranty details and exclusions).

Standard accessories packaged with each model will have a one-year factory warranty.

Accessory items have a one-year factory warranty.

Shipping to our facility is not covered in our warranty. Return shipping is included within the US.

This warranty is non-transferrable.

For the sake of clarity, ‘repair or replace the Product or its defective part’ does not include removal or installation work, costs or expenses which include but are not limited to labor costs or expenses.

Cobra will not be responsible for lost packages.

©2024 Cobra Electronics Corporation. Cobra and the snake design are proprietary trademarks of Cobra Electronics Corporation, USA. Other trademarks and trade names are those of their respective owners.

Cobra Electronics Corporation™ is a trademark of Cobra Electronics Corporation, USA.

