

TA7222AP

T-74-05-01

5.8W AUDIO POWER AMPLIFIER

CAR STEREO CAR RADIO AUDIO OUTPUT

- Very Few External Parts (Require 4 PCS Capacitor)
- Adjustable Closed-Loop Gain
- High Sustaining Over Voltage
(Surge voltage up to 40V for 0.2sec. pin 1 to 8)
- Excellent Ripple Rejection
- High Power and Low Distortion :
 $P_{OUT}=5.8W(\text{Typ.})$ at $V_{CC}=13.2V$, $R_L=4\Omega$, THD=10%
 $THD=0.2\%(\text{Typ.})$
- Possible to Use for 2Ω Load :
 $P_{OUT}=9.3W(\text{Typ.})$ at $V_{CC}=13.2V$, THD=10%
- Operating Supply Voltage Range : $V_{CC}=8 \sim 18V$
- Audio Muting Circuit
- Protection Circuit (for Load Short, Excessive
Supply Voltage and Thermal Shut-down)

MAXIMUM RATINGS ($T_a=25^\circ C$)

CHARACTERISTIC	SYMBOL	RATING..	UNIT
Peak Supply Voltage (200ms)	V_{CC} surge	40	V
D.C Supply Voltage	$V_{CC}(\text{DC})$	25	V
Operating Supply Voltage	$V_{CC}(\text{ope})$	18	V
Output Current (Peak)	$I_{O}(\text{peak})$	4.5	A
Power Dissipation ($T_c=25^\circ C$)	P_d	12.5	W
Operating Temperature	P_{opr}	$-30 \sim 75$	$^\circ C$
Storage Temperature	T_{stg}	$-55 \sim 150$	$^\circ C$

ELECTRICAL CHARACTERISTICS

(Unless otherwise specified, $V_{CC}=12.5V$, $R_L=4\Omega$, $R_g=600\Omega$, $f=1kHz$, $T_a=25^\circ C$)

CHARACTERISTIC	SYMBOL	TEST CIRCUIT	TEST CONDITION	MIN.	TYP.	MAX.	UNIT
Quiescent Current	I_{CCQ}	-	-	-	40	80	mA
			$V_{CC}=18V$	-	45	100	
Output Power	P_{OUT}	-	THD=10%	-	5.2	-	W
			$V_{CC}=13.2V$, THD=10%	5.0	5.8	-	
			$V_{CC}=13.2V$, $R_L=2\Omega$, THD=10%	-	9.3	-	
Maximum Output Power	P_{OM}	-	$V_{CC}=13.2V$, $V_{IN}=100mV$	-	9.0	-	W
Total Harmonic Distortion	THD	-	$P_{OUT}=1W$	-	0.2	1.5	%
			$P_{OUT}=100mW$	-	0.36	1.0	
			$P_{OUT}=1W$, $R_L=2\Omega$	-	0.5	-	
Voltage Gain	G_v	-	-	51.5	53	54.5	dB
Input Resistance	R_{IN}	-	-	-	34	-	k Ω
Output Noise Voltage	V_{NO}	-	$R_g=10k\Omega$, BW=50~20kHz	-	0.9	2.0	mV

Unit in mm

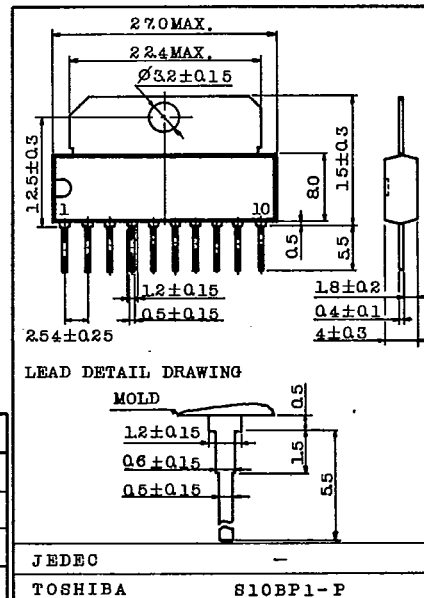

AUDIO LINEAR IC

TA7222AP

T-74-05-01

BLOCK DIAGRAM AND TEST CIRCUIT

FIG-1

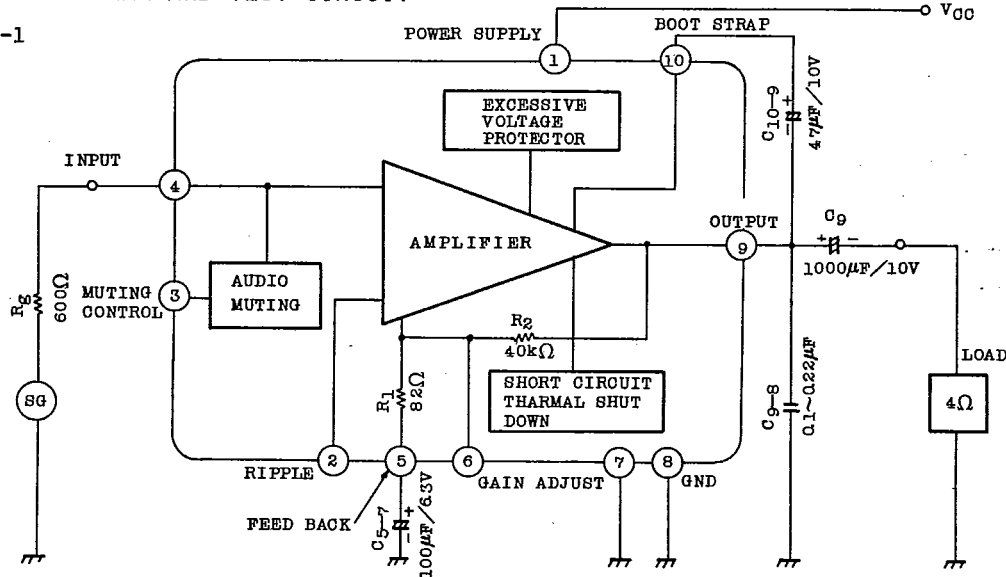

1. Terminal ⑦ is input stage GND, terminal ⑧ is output stage GND.
 2. Closed-loop voltage gain of the amplifier is determined by the ratio ; $(R_1+R_2)/R_1$. TA7222AP is fixed at typically 53.0 dB for designing minimum external components.
 - When higher closed loop gain is desired, the gain can be increased by connecting a resistor between pin ⑤ and pin ⑥ . Open loop gain is obtained by shortening pin ⑤ and pin ⑥ .
 - When lower closed loop gain is desired, the following two ways can be used.
 - A. Series connecting a resistor and a capacitor between pin ⑥ and pin ⑨ .
 - B. Series adding a resistor to pin ⑥.
- Both A and B, lower closed loop gain than 40 dB is not recommended. And also, ripple rejection ratio is decreased by using B configuration in such a case, connecting a capacitor from pin ② to ground is recommended. (Fig.2,3,4 show these ways.)
3. For applications requiring high ripple rejection ratio, an excellent supply voltage ripple rejection is obtained by connecting a capacitor (recommended value $4.7\mu\text{F}$) between pin ② and ground. (R.R-f shows these characteristics)
 4. Terminal ③ is Audio Muting Control Input.
 - When control input is low state (; open or below 0.3V), muting circuit does not operate, OFF.
 - When control input is high state (; above 1.0V), muting circuit, then, operates, ON. (Refer to Fig.5)

TA7222AP

T-74-05-01

APPLICATION CIRCUIT

HIGHER CLOSED LOOP GAIN CIRCUIT

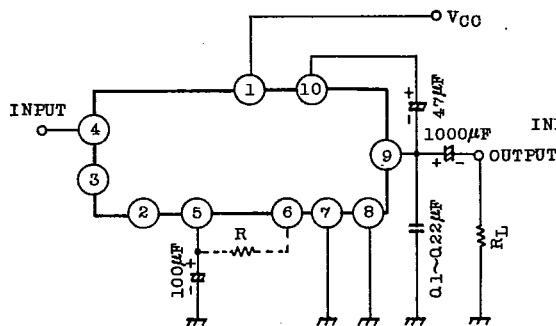

FIG-2

LOWER CLOSED LOOP GAIN CIRCUIT (A)

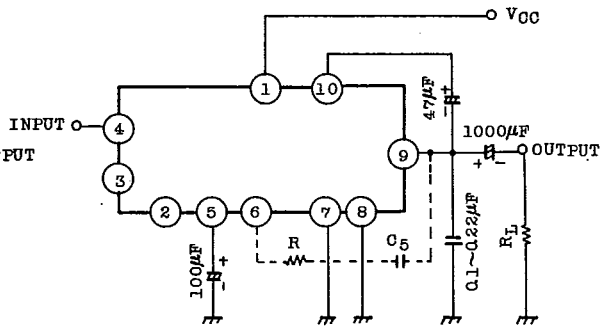
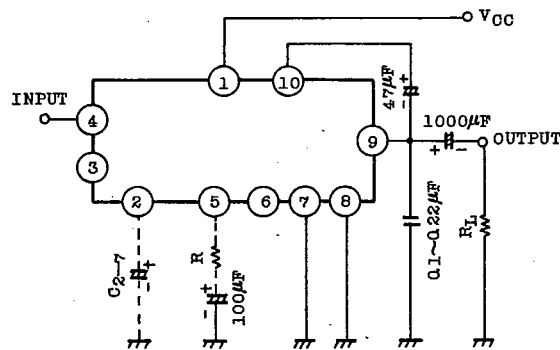

FIG-3

LOWER CLOSED LOOP GAIN CIRCUIT (B)



Note : Capacitor C₂₋₇ must be used when high ripple rejection ratio is requested.

FIG-4

AUDIO MUTING CIRCUIT

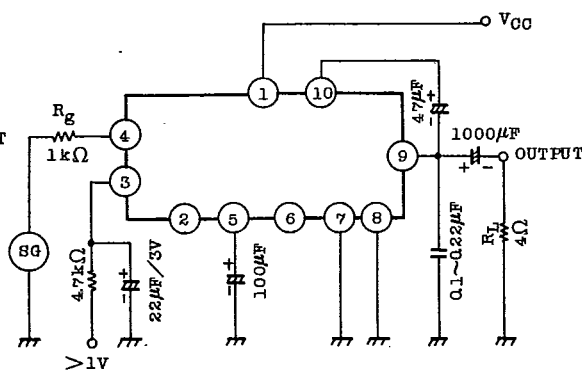

Note : Power output reduction level
 -40dB at R_g=1kΩ
 -35dB at R_g=0

FIG-5

AUDIO LINEAR IC

TA7222AP

T-74-05-01

RIPPLE REJECTION - f

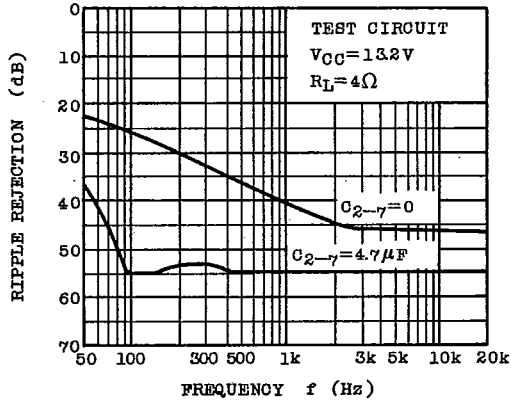

$G_{VO}, G_V - f$

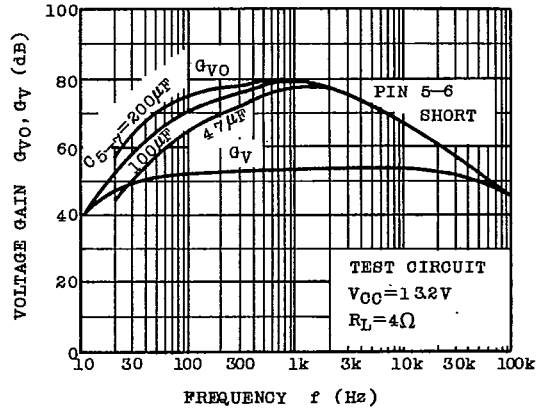

THD - P_{OUT}

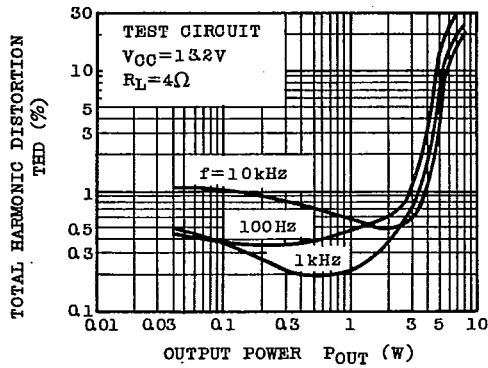

THD - P_{OUT}

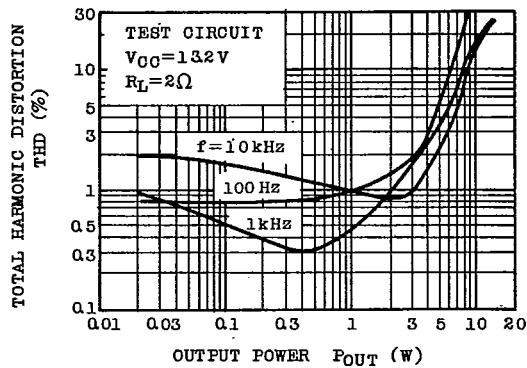

P_{OUT} - V_{CC}

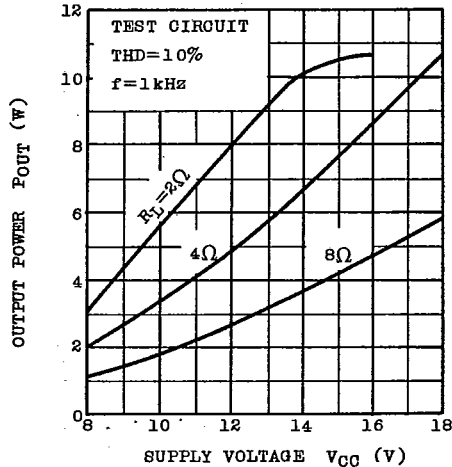

I_{CC} - V_{CC}

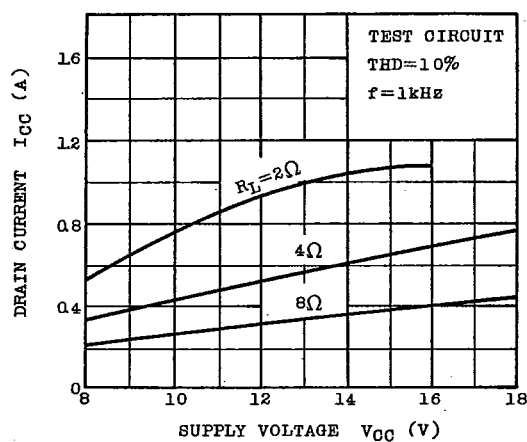

TA7222AP

T-74-05-01

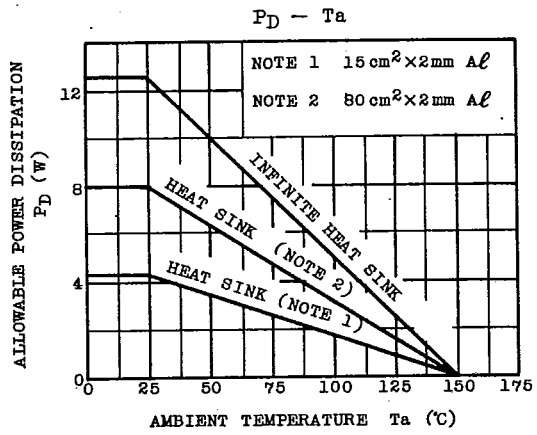
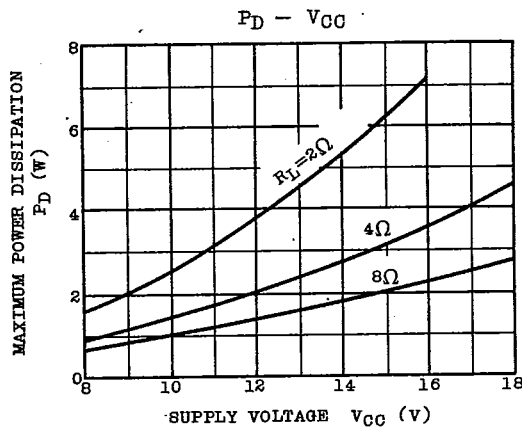

AUDIO LINEAR IC