

PRESIDENT

TEDDY ASC

SERVICE MANUAL

-TECNNICAL CHARACTERITICS

TEDDY ASC (config : EU d EC U PL)

1-GENERAL:

-Multiconfiguration(E,d,EU,EC,U,PL)

-EU⇒ 40 channels AM/FM 4W (from 26,965Mhz to 27,405Mhz)

-d ⇒ 80 channels FM 4W (from 26,565Mhz to 27,405Mhz)

40 channels AM 4W (from 26,965Mhz to 27,405Mhz)

-EC ⇒ 40 channels FM 4W (from 26,965Mhz to 27,405Mhz)

-U ⇒ 40 channels CEPT FM 4W (from 26,965Mhz to 27,405Mhz)

40 channels FM UK 4W (from 27,60125Mhz to 27,99125Mhz)

-PL ⇒ 40 channels AM/FM 4W (from 26,960Mhz to 27,400Mhz)

-Channel step

-10KHz

-Class of emission

-AM(A3E)/FM(F3E)

-Power supply

-13,2V (from10,8V to 15,6V)

-Antenna impedance

-50Ω

-Dimensions(in mm)

-125(L)x45(H)x170(D)

-Weight

-0,6Kg

2-TRANSMISSION:

-Frequency allowance

-±200Hz

-Transmission interference

-Inferior to 4nW(-54dBm)

-Audio frequency response

-From 300Hz to 3kHz in AM/FM

-Emitted power in the adjacent channel

-Inferior to 20μW

-Microphone sensitivity

-Inferior to 10mV

-Current drain

-1,8A(in transmission mode with modulation)

-Modulated signal distortion

-Inferior to 2%

3-RECEPTION:

-Maximum sensitivity at 20dB sinad

-0,5 μ V(-113dBm) AM/FM

-Audio frequency response

-From 300Hz to 3kHz in AM/FM

-Adjacent channel selectivity

-Superior to 60dB AM/FM

-Frequency image rejection

-Superior to 60dB AM/FM

-Intermodulation response

-Superior to 48 dB AM and 54dB FM

-Maximum audio power

-2W

-Squelch sensitivity

-Threshold 0,2 μ V(-120dBm)/Tight 1mV(-47dBm)

-Current drain

-600mA nominal/950mA maximum

ALIGNMENT PROCEDURE (TEDDY ASC)

* VCO/PLL PORTION

- Alignment procedure
- Frequencies chart
- Test points

* TRANSMITTER

- Alignment procedure
- Test points

* RECEIVER

- Alignment procedure
- Test points

Test equipment required

Frequency counter 200 Mhz	HF Generator
DC Voltmeter	BF Voltmeter
Distortimeter	HF Voltmeter
Wattmeter - Dummy load	Osilloscope
FM linear detector	Load 8 Ω
AF generator	Sinad meter

Conditions of Measurements on HF Generator

Reception

AM mode: Level - 107 dBm Frequency 1 KHz with 60% of modulation.
FM mode: Level - 107 dBm Frequency 1 KHz with 1,2KHz of deviation.

Transmission

Frequency 1 KHz 30mV.

ALIGNMENT VCO/PLL

1 - Alignment procedure(13,2V;configuration"EU, d")

STEP	CONDITION	ADJUSTMENT	REMARKS OF ADJUSTMENT
1	AM/FM(EU) RX mode Channel 20	RT350	Connect a frequency counter to TP200,and adjust RT350 to reach 37,900MHz.
2	AM/FM(EU) TX/RX mode Channel 40		Connect a voltmeter to TP 103,and check: Tx Channel 40=2,5V±0,2V Rx Channel 40=2,6V±0,2V
3	AM/FM(EU) TX/RX mode Channel 1		Connect a voltmeter to TP 103,and check: Tx Channel 1=2,1V±0,2V Rx Channel 1=2,3V±0,2V
4	AM/FM(EU) TX/RX mode Channel 1 to 40 or 1 to 80(d)		Connect a frequency counter to TP200,and check frequencies.

- FREQUENCY LIST (EU, EC)

CH	Channels Frequencies (MHz)	VCO Frequencies (MHz)
1	26,965	37,660
2	26,975	37,670
3	26,985	37,680
4	27,005	37,700
5	27,015	37,710
6	27,025	37,720
7	27,035	37,730
8	27,055	37,750
9	27,065	37,760
10	27,075	37,770
11	27,085	37,780
12	27,105	37,800
13	27,115	37,810
14	27,125	37,820
15	27,135	37,830
16	27,155	37,850
17	27,165	37,860
18	27,175	37,870
19	27,185	37,880
20	27,205	37,900
21	27,215	37,910
22	27,225	37,930
23	27,255	37,950
24	27,235	37,930
25	27,245	37,940
26	27,265	37,960
27	27,275	37,970
28	27,285	37,980
29	27,295	37,990
30	27,305	38,000
31	27,315	38,010
32	27,325	38,020
33	27,335	38,030
34	27,345	38,040
35	27,355	38,050
36	27,365	38,060
37	27,375	38,070
38	27,385	38,080
39	27,395	38,090
40	27,405	38,100

- FREQUENCY LIST (PL)

CH	Channels Frequencies (MHz)	VCO Frequencies (MHz)
1	26,960	37,655
2	26,970	37,665
3	26,980	37,675
4	27,000	37,695
5	27,010	37,705
6	27,020	37,715
7	27,030	37,725
8	27,050	37,745
9	27,060	37,755
10	27,070	37,765
11	27,080	37,775
12	27,100	37,795
13	27,110	37,805
14	27,120	37,815
15	27,130	37,825
16	27,150	37,845
17	27,160	37,855
18	27,170	37,865
19	27,180	37,875
20	27,200	37,895
21	27,210	37,905
22	27,220	37,915
23	27,250	37,945
24	27,230	37,925
25	27,240	37,935
26	27,260	37,955
27	27,270	37,965
28	27,280	37,975
29	27,290	37,985
30	27,300	37,995
31	27,310	38,005
32	27,320	38,015
33	27,330	38,025
34	27,340	38,035
35	27,350	38,045
36	27,360	38,055
37	27,370	38,065
38	27,380	38,075
39	27,390	38,085
40	27,400	38,095

- FREQUENCY LIST (U)

CH CEPT	Channels Frequencies (MHz)	VCO Frequencies (MHz)
1	26,965	37,660
2	26,975	37,670
3	26,985	37,680
4	27,005	37,700
5	27,015	37,710
6	27,025	37,720
7	27,035	37,730
8	27,055	37,750
9	27,065	37,760
10	27,075	37,770
11	27,085	37,780
12	27,105	37,800
13	27,115	37,810
14	27,125	37,820
15	27,135	37,830
16	27,155	37,850
17	27,165	37,860
18	27,175	37,870
19	27,185	37,880
20	27,205	37,900
21	27,215	37,910
22	27,225	37,930
23	27,255	37,950
24	27,235	37,930
25	27,245	37,940
26	27,265	37,960
27	27,275	37,970
28	27,285	37,980
29	27,295	37,990
30	27,305	38,000
31	27,315	38,010
32	27,325	38,020
33	27,335	38,030
34	27,345	38,040
35	27,355	38,050
36	27,365	38,060
37	27,375	38,070
38	27,385	38,080
39	27,395	38,090
40	27,405	38,100

- FREQUENCY LIST (U)

CH UK	Channels Frequencies (MHz)	VCO Frequencies (MHz)
1	27,60125	38,29625
2	27,61125	38,30625
3	27,62125	38,31625
4	27,63125	38,32625
5	27,64125	38,33625
6	27,65125	38,34625
7	27,66125	38,35625
8	27,67125	38,36625
9	27,68125	38,37625
10	27,69125	38,38625
11	27,70125	38,39625
12	27,71125	38,40625
13	27,72125	38,41625
14	27,73125	38,42625
15	27,74125	38,43625
16	27,75125	38,44625
17	27,76125	38,45625
18	27,77125	38,46625
19	27,78125	38,47625
20	27,79125	38,48625
21	27,80125	38,49625
22	27,81125	38,50625
23	27,82125	38,51625
24	27,83125	38,52625
25	27,84125	38,53625
26	27,85125	38,54625
27	27,86125	38,55625
28	27,87125	38,56625
29	27,88125	38,57625
30	27,89125	38,58625
31	27,90125	38,59625
32	27,91125	38,60625
33	27,92125	38,61625
34	27,93125	38,62625
35	27,94125	38,63625
36	27,95125	38,64625
37	27,96125	38,65625
38	27,97125	38,66625
39	27,98125	38,67625
40	27,99125	38,68625

- FREQUENCY LIST (d)

CH	Channels	VCO	CH	Channels	VCO
D	Frequencies (MHz)	Frequencies (MHz)	D	Frequencies (MHz)	Frequencies (MHz)
1	26,965	37,660	41	26,565	37,260
2	26,975	37,670	42	26,575	37,270
3	26,985	37,680	43	26,585	37,280
4	27,005	37,70	44	26,595	37,290
5	27,015	37,710	45	26,605	37,300
6	27,025	37,720	46	26,615	37,310
7	27,035	37,730	47	26,625	37,320
8	27,055	37,750	48	26,635	37,330
9	27,065	37,760	49	26,645	37,340
10	27,075	37,770	50	26,655	37,350
11	27,085	37,780	51	26,665	37,360
12	27,105	37,800	52	26,675	37,370
13	27,115	37,810	53	26,685	37,380
14	27,125	37,820	54	26,695	37,390
15	27,135	37,830	55	26,705	37,400
16	27,155	37,850	56	26,715	37,410
17	27,165	37,860	57	26,725	37,420
18	27,175	37,870	58	26,735	37,430
19	27,185	37,880	59	26,745	37,440
20	27,205	37,900	60	26,755	37,450
21	27,215	37,910	61	26,765	37,460
22	27,225	37,930	62	26,775	37,470
23	27,255	37,950	63	26,785	37,480
24	27,235	37,930	64	26,795	37,490
25	27,245	37,940	65	26,805	37,500
26	27,265	37,960	66	26,815	37,510
27	27,275	37,970	67	26,825	37,520
28	27,285	37,980	68	26,835	37,530
29	27,295	37,990	69	26,845	37,540
30	27,305	38,000	70	26,855	37,550
31	27,315	38,010	71	26,865	37,560
32	27,325	38,020	72	26,875	37,570
33	27,335	38,030	73	26,885	37,580
34	27,345	38,040	74	26,895	37,590
35	27,355	38,050	75	26,905	37,600
36	27,365	38,060	76	26,915	37,610
37	27,375	38,070	77	26,925	37,620
38	27,385	38,080	78	26,935	37,630
39	27,395	38,090	79	26,945	37,640
40	27,405	38,100	80	26,955	37,650

VCO/PLL ALIGNMENT POINTS

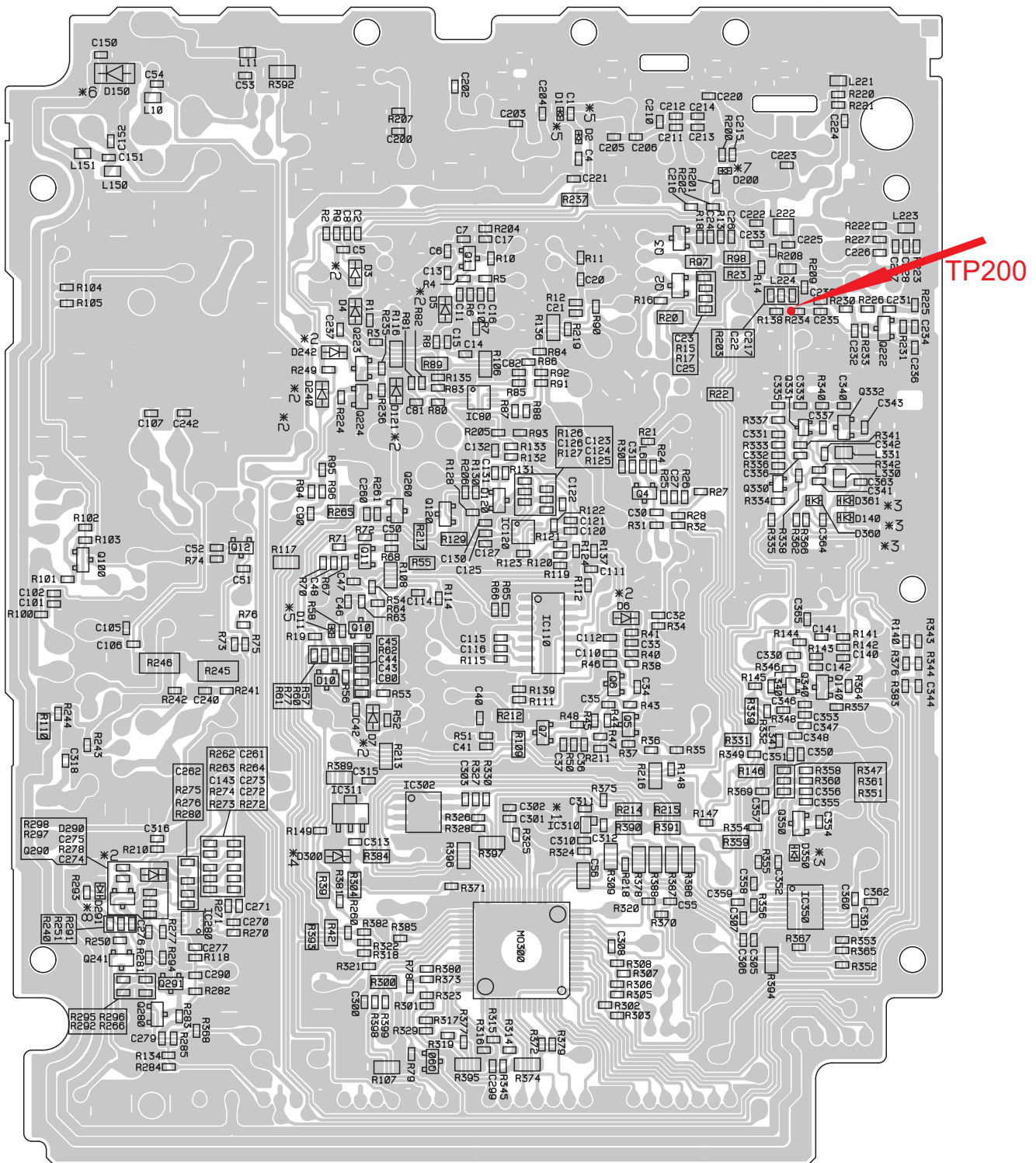

ALIGNMENT TRANSMITTER

1 - Alignment procedure(13,2V;configuration'EU')

STEP	CONDITION	ADJUSTMENT	REMARKS OF ADJUSTMENT
1	FM/AM(EU)TX Channel 20	RT240	Connect a wattmeter to jack antenna, adjust RT240 to reach 4W on the wattmeter.
2	Same as 1		Connect a dummy load to jack antenna. Check that the "RF meter" display 4 digits.
3	FM(EU)TX Mod 30 mV 1 KHz CH 20	RT140	Adjust RT140 to reach $\pm 1,2$ KHz of deviation.
4	AM(EU)TX Mod 30 mV 1 KHz CH 20	RT241/RT260	First: Adjust RT241 and RT260 to the maximum of modulation, then adjust RT260 to reach $\pm 90\%$ of modulation, then adjust RT241 to reach $\pm 85\%$ of modulation.

ALIGNMENT RECEIVER

1 - Alignment procedure(13,2V;configuration"EU")

STEP	CONDITION	ADJUSTMENT	REMARKS OF ADJUSTMENT
1	AM(EU) Channel 20 Middle volume level. No squelch active	L1-L2-L3 L4-L5-L7	Connect HF generator to jack antenna adjusted at (-107dBm 1KHz 60%), connect sinad meter to jack EXT speaker and adjust coils(L1, L2, L3, L4, L5, L7) for maximum sensitivity ($\geq 20\text{dB}$ sinad).
2	FM(EU) Channel 20 Middle volume level No squelch active	L 110	Connect HF generator to jack antenna adjusted at (-107dBm 1KHz 1,2KHz Dev),connect sinad meter to jack EXT speaker and adjust L110 for maximum sensitivity($\geq 20\text{dB}$ sinad).
3	AM(EU) Channel 20 Middle volume level No squelch active	RT80(S-METER)	Connect HF generator to jack antenna adjusted at (-67dBm 1KHz 60%) and adjust RT80 so that the "S meter" display 4 digits.
4	AM(EU) Channel 20 Middle volume level Squelch maximum clockwise	RT81(SQ)	Connect HF generator to jack antenna adjusted at (-47dBm 1KHz 60%) and adjust RT81 so that the signal is audible .
5	AM(EU) Channel 20 Middle volume level Squelch maximum counterclockwise (ASC)		Connect HF generator to jack antenna. Connect sinad meter to jack EXT speaker, adjust the ouput level of HF generator and check that the opening ASC sinad is $12\text{dB}\pm 2\text{dB}$.

TEDDY ASC

BLOC DIAGRAM

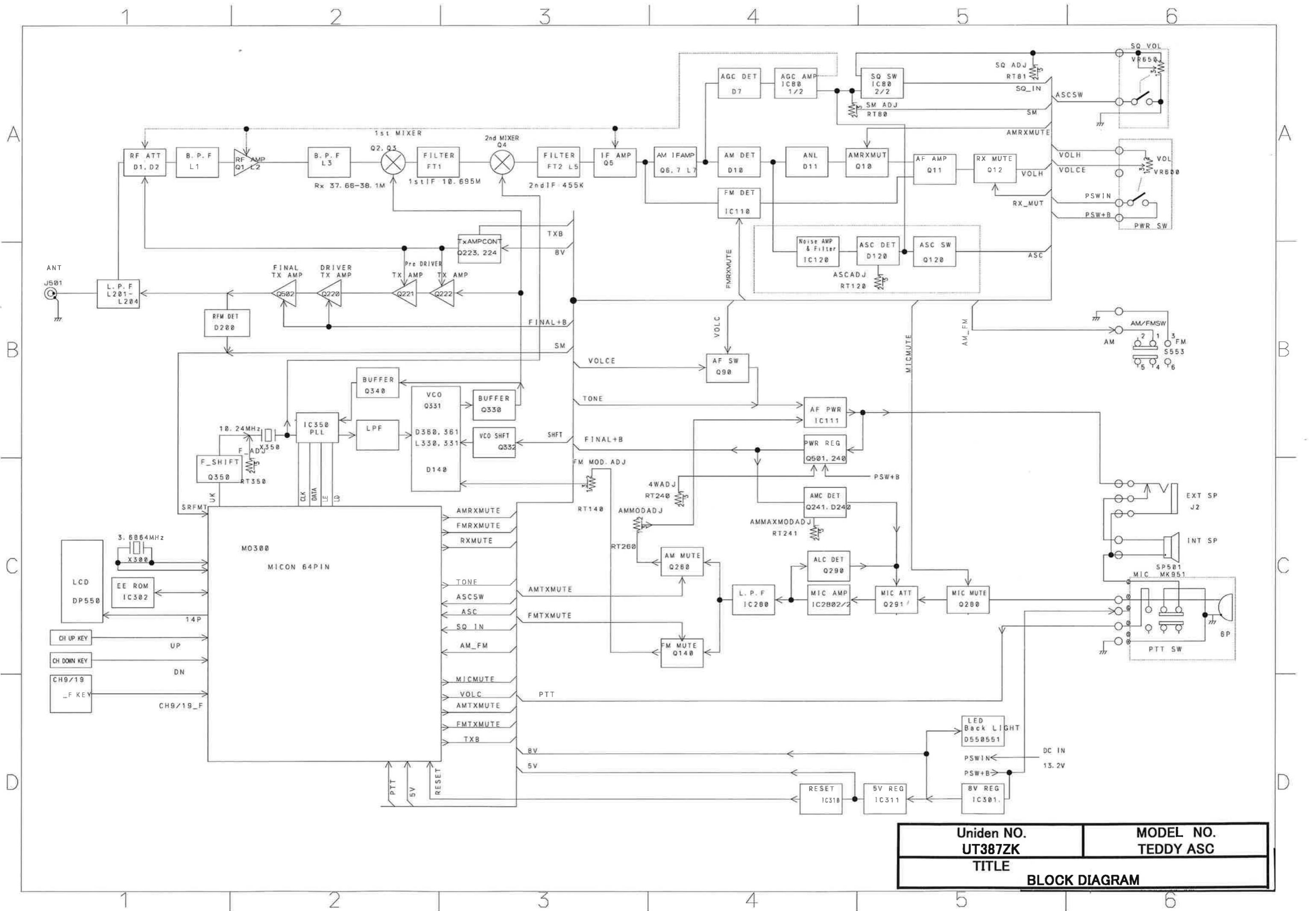

Uniden NO. UT387ZK	MODEL NO. TEDDY ASC
TITLE BLOCK DIAGRAM	

TEDDY ASC

SCHEMATIC DIAGRAM

USE Pb FREE SOLDER

☉ : SOLDERING

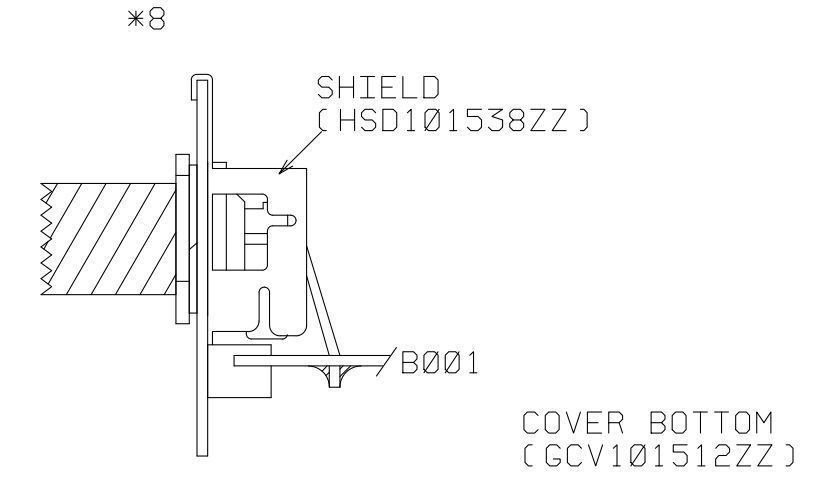
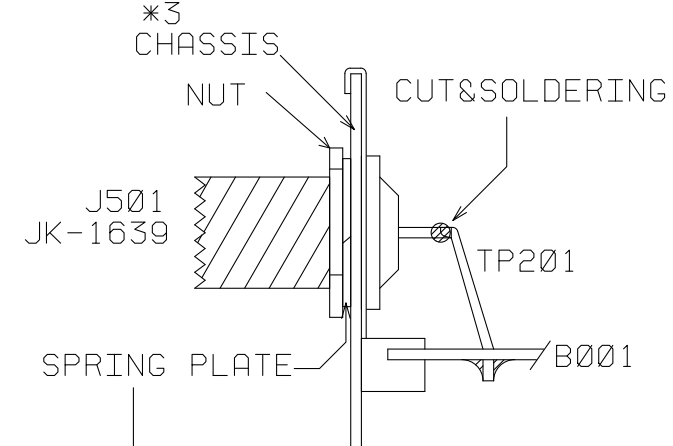
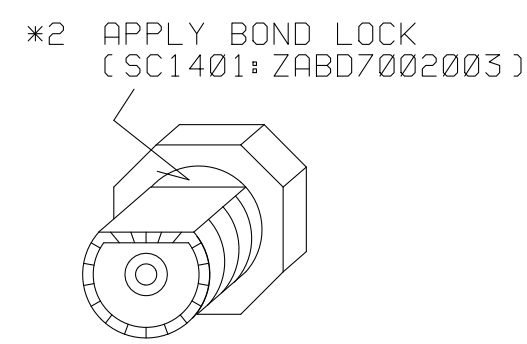
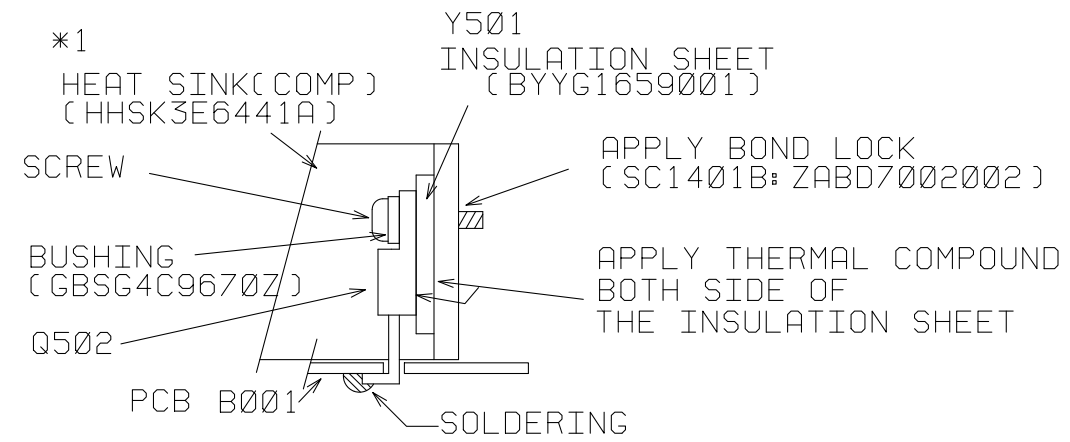

B001 PA-471(1/4) [BOTTOM VIEW]

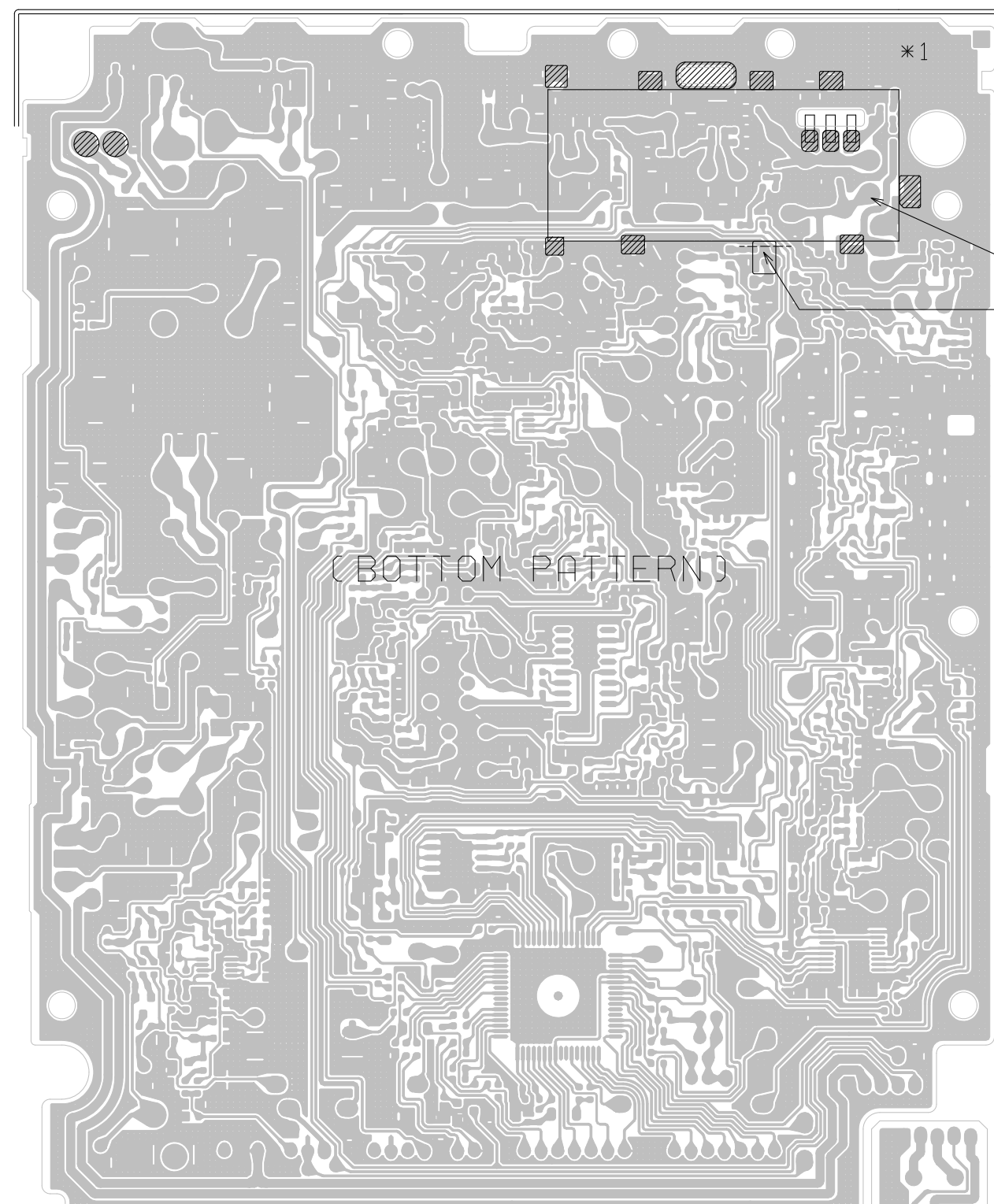

B001 [TOP VIEW]

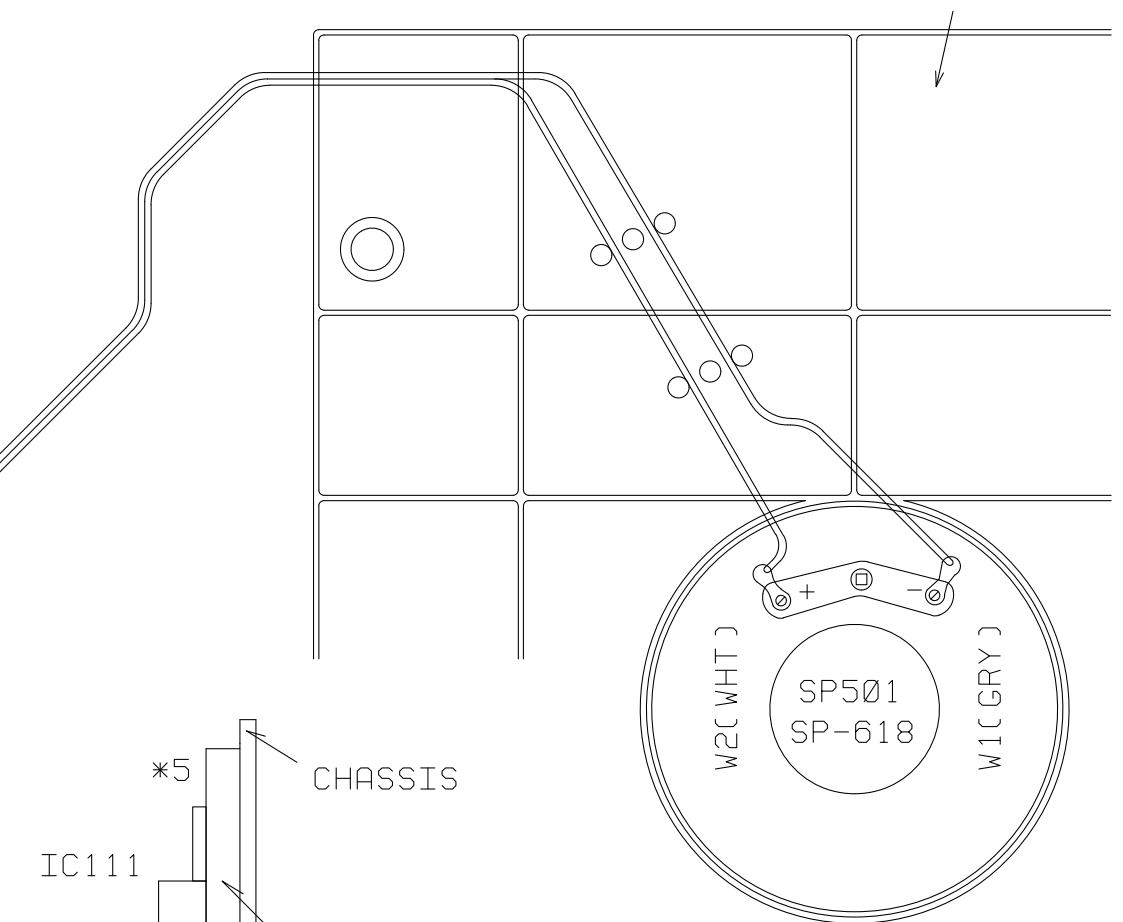
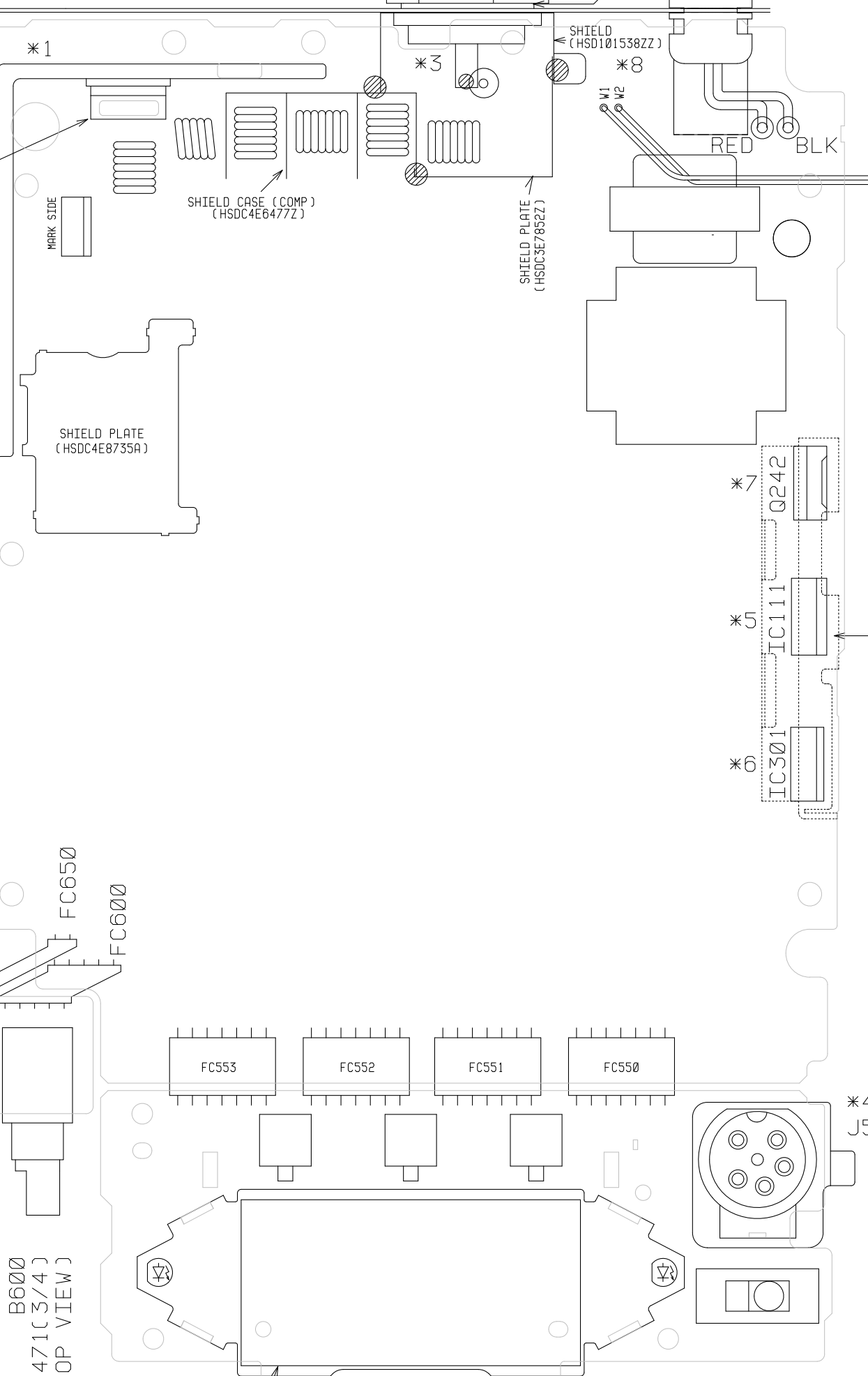

B550 PA-471(2/4) [BOTTOM VIEW]

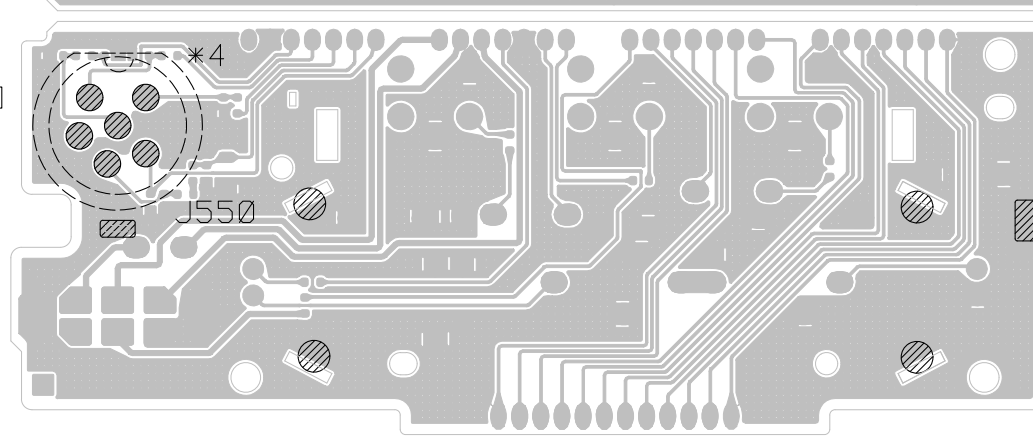

B650 PA-471(4/4) [TOP VIEW]

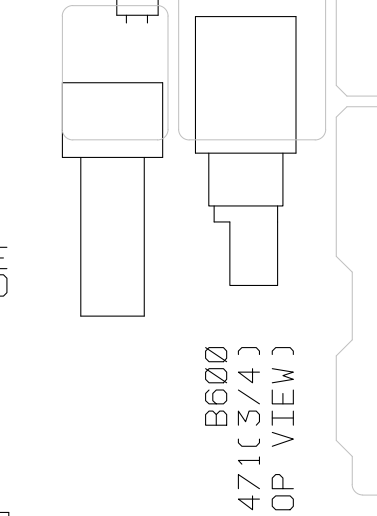

B600 PA-471(3/4) [TOP VIEW]

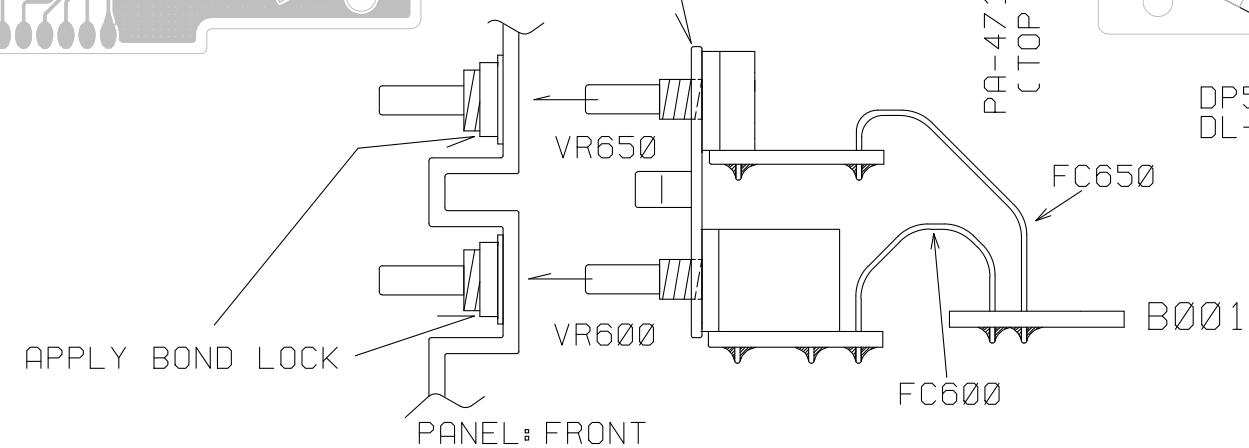

DP551 DL-659

FRAME (HFR101515ZZ)

DESIGN. BY	YITO	DRAWN. BY	YITO	UNIDEN NO.	UT387ZK	MODEL NO.	TEDDY ASC
CHECK. BY	HASE	APPRO. BY	KUNIMITSU	TITLE	WIRING DIAGRAM		
REV. NO.				DRAWING NO.	E32-5861		
					UNIDEN CORP.		

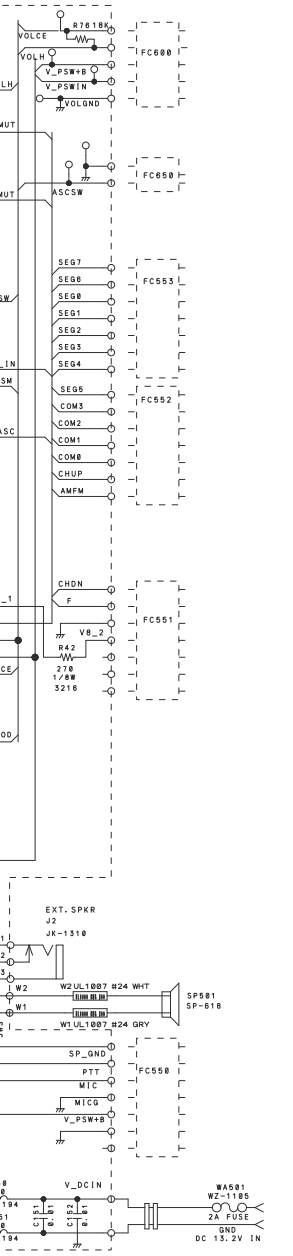
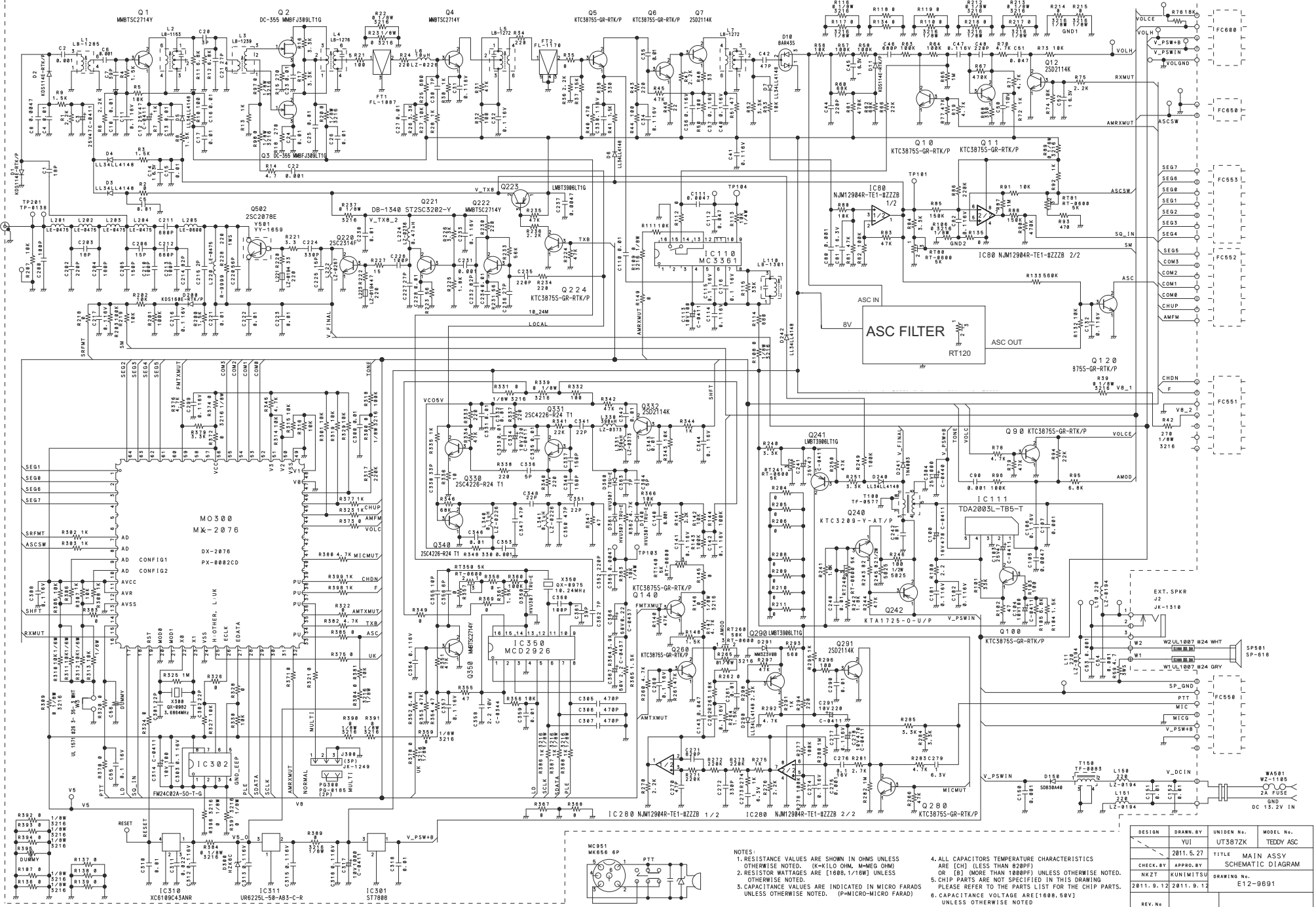

- NOTES:
1. RESISTANCE VALUES ARE SHOWN IN OHMS UNLESS OTHERWISE NOTED. (K=KILO OHM, M=MEG OHM)
 2. RESISTOR WATTAGES ARE [100W, 1/16W] UNLESS OTHERWISE NOTED.
 3. CAPACITANCE VALUES ARE INDICATED IN MICRO FARADS UNLESS OTHERWISE NOTED. (P=MICRO-MICRO FARAD)
 4. ALL CAPACITORS TEMPERATURE CHARACTERISTICS ARE [C] (LESS THAN 820PF) OR [B] (MORE THAN 1000PF) UNLESS OTHERWISE NOTED.
 5. CHIP PARTS ARE NOT SPECIFIED IN THIS DRAWING PLEASE REFER TO THE PARTS LIST FOR THE CHIP PARTS.
 6. CAPACITANCE VOLTAGE ARE [100V, 50V] UNLESS OTHERWISE NOTED

DESIGN	DRAWN BY	UNIDEN No.	MODEL No.
	YU	UT3872K	TEDDY ASC
	2011.5.27		TITLE MAIN ASSY
			SCHEMATIC DIAGRAM
CHECK BY	APPROV BY		
NKZT	KUNIMITSU		DRAWING No.
2011.9.12	2011.9.12		E12-9691
REV. No			

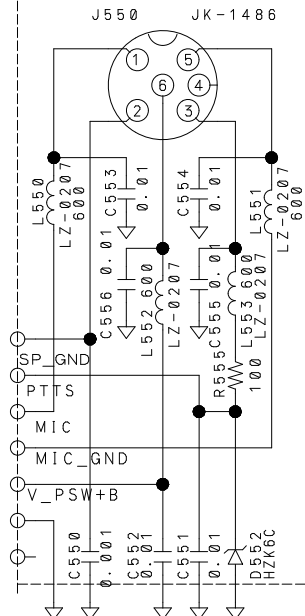
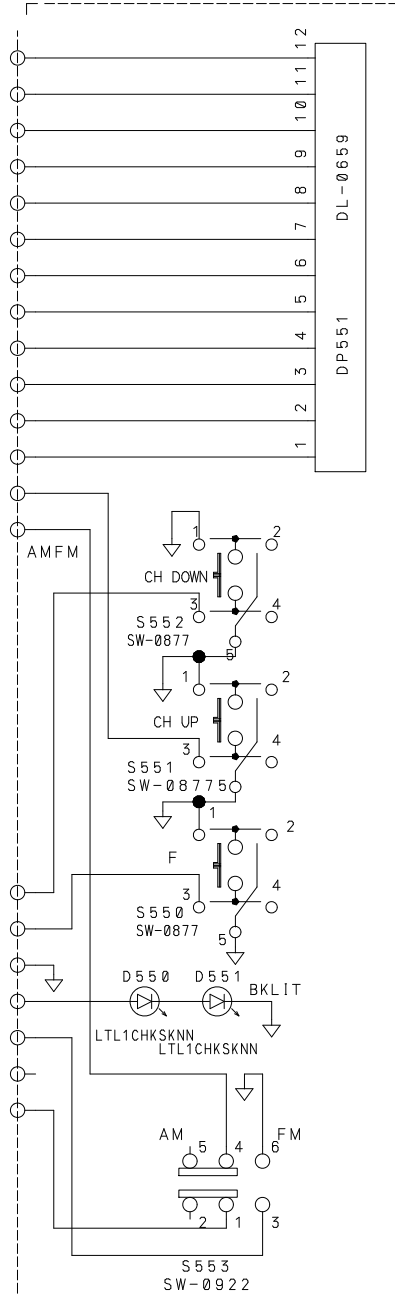
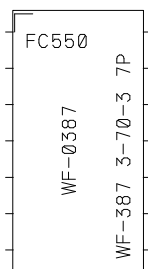
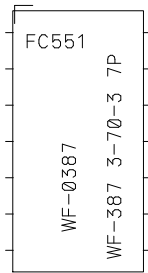
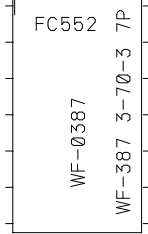
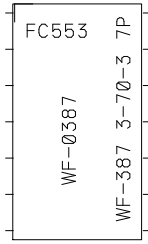

NOTES:

1. RESISTANCE VALUES ARE SHOWN IN OHMS UNLESS OTHERWISE NOTED. (K=KILO OHM, M=MEG OHM)
2. RESISTOR WATTAGES ARE [1/8W, 1/4W, 1/2W] UNLESS OTHERWISE NOTED.
3. CAPACITANCE VALUES ARE INDICATED IN MICRO FARADS UNLESS OTHERWISE NOTED. (P=MICRO-MICRO FARAD)
4. ALL CAPACITORS TEMPERATURE CHARACTERISTICS ARE [CH] (LESS THAN 820PF) OR [B] (MORE THAN 1000PF) UNLESS OTHERWISE NOTED.
5. CHIP PARTS ARE NOT SPECIFIED IN THIS DRAWING PLEASE REFER TO THE PARTS LIST FOR THE CHIP PARTS.

DESIGN	DRAWN BY	UNIDEN No.	MODEL No.
	YUI	UT387ZK	TEDDY ASC
	2011.5.27	TITLE FRONT ASSY SCHEMATIC DIAGRAM	
CHECK BY	APPRO BY	DRAWING No.	
NKZT	KUNIMITSU	E14-9692	
2011.9.12	2011.9.12		
REV. No			

1

2

3

4

5

6

A

A

B

B

C

C

D

D

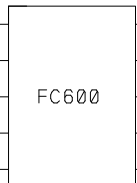

WF-0385
WF-385 3-50-3 5P

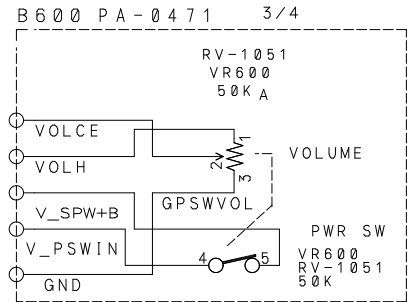

DESIGN	DRAWN. BY	UNIDEN No.	MODEL No.
	YUI	UT387ZK	TEDDY ASC
	2011.5.27	TITLE VOL ASSY SCHEMATIC DIAGRAM	
CHECK. BY	APPRO. BY	DRAWING No.	
NKZT	KUNIMITSU	E14-9694	
2011.9.9	2011.9.9		
REV. No			

1

2

3

4

5

6

1

2

3

4

5

6

A

A

B

B

C

C

D

D

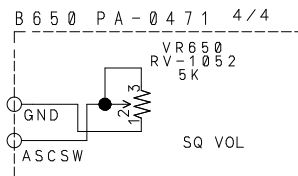
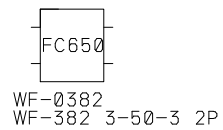

DESIGN	DRAWN. BY	UNIDEN No.	MODEL No.
	YUI	UT387ZK	TEDDY ASC
	2011.5.27	TITLE SWITCH ASSY SCHEMATIC DIAGRAM	
CHECK. BY	APPRO. BY	DRAWING No.	
NKZT	KUNIMITSU	E14-9693	
2011.9.9	2011.9.9		
REV. No			

1

2

3

4

5

6

TEDDY ASC

COMPONENT LAYOUT

USE Pb FREE SOLDER

B1 PA-0471AA 1/4 (BOTTOM VIEW)

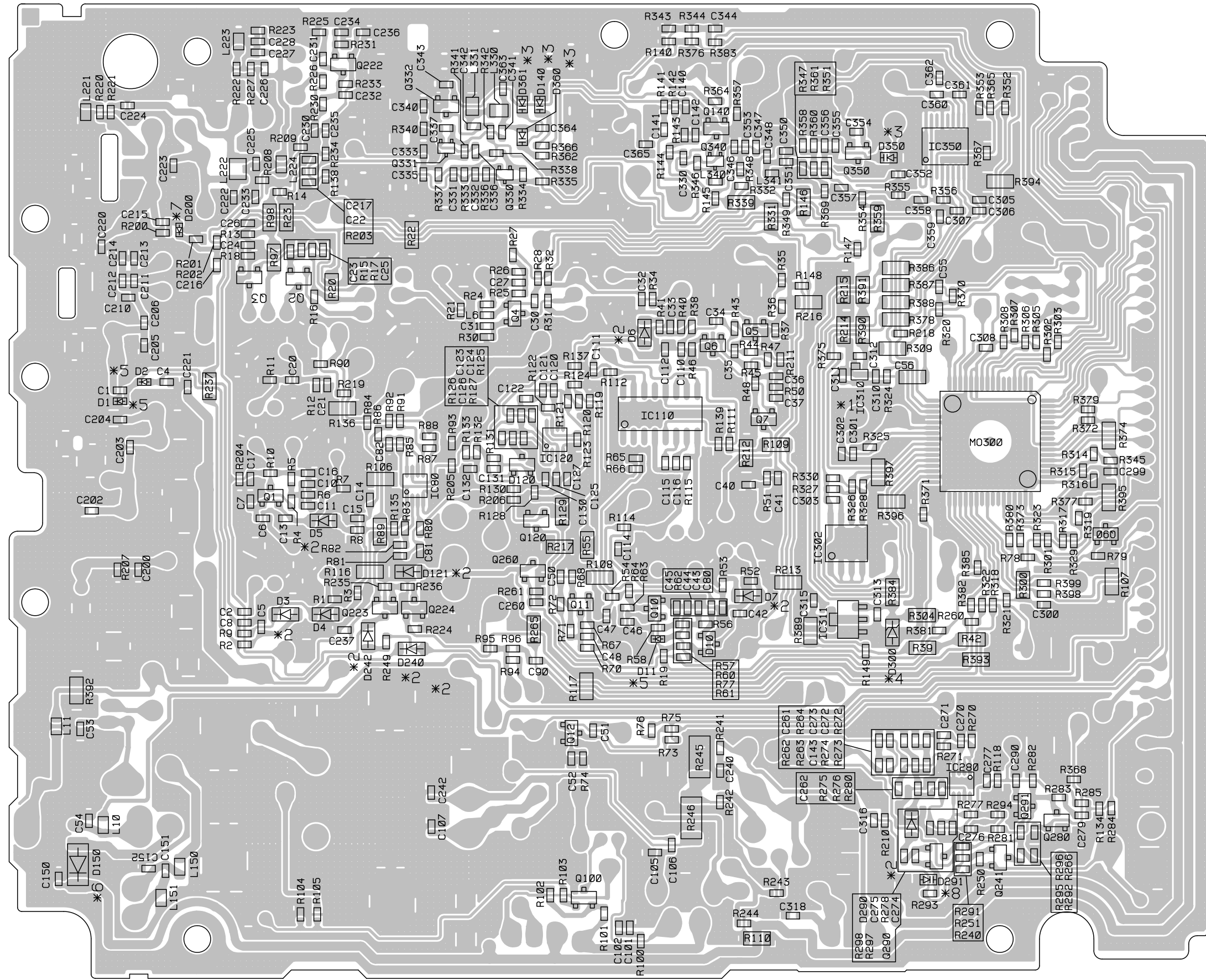

*1 IC310
PIN POSITION

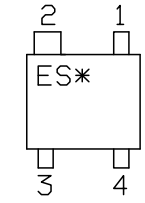

*5 DIRECTION

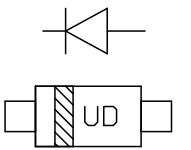

*2 DIRECTION

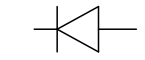

*6 DIRECTION

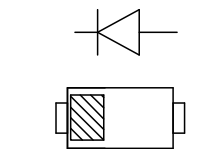
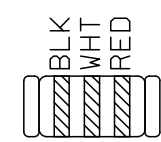

*3 DIRECTION



*7 DIRECTION

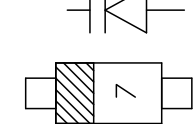

*8 DIRECTION

*4 DIRECTION

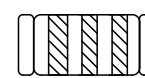
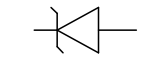

YELLOW
GREEN
VERDURE (GREEN)
LIGHT BLUE

DESIGN. BY YUI	DRAWN. BY YITO	UNIDEN NO. UT387ZK	MODEL NO. TEDDY ASC
11/04/19	11/08/10	TITLE MAIN ASS'Y CHIP LAYOUT BOTTOM VIEW 1/3	
CHECK. BY YITO	APPRO. BY KUNIMITSU	DRAWING NO. E23-31407	
11/08/10	11/08/10		
REV. NO.		UNIDEN CORP.	

USE Pb FREE SOLDER

B550 PA-0471AA 2/4 (TOP VIEW)

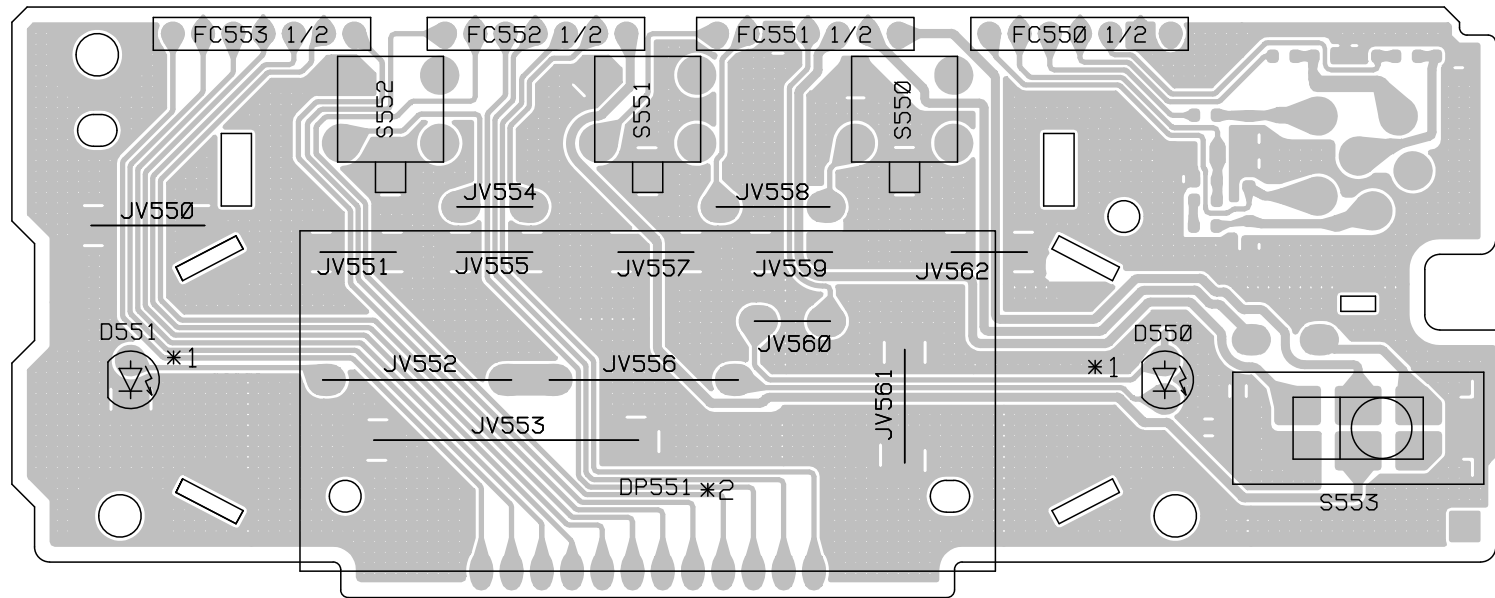

*1 DIRECTION

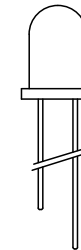

*2 DP551 : HOW TO MOUNT

PLEASE SEE MECHA ASS'Y DROWING.

D550	LTL1CHSKNN
D551	LTL1CHSKNN

DP551	DL-0659 912-442A-4611
-------	--------------------------

JV550	7.5MM
JV551	5MM
JV552	12.5MM
JV553	17.5MM
JV554	5MM
JV555	5MM
JV556	12.5MM
JV557	5MM
JV558	7.5MM
JV559	5MM
JV560	5MM
JV561	7.5MM
JV562	5MM

S550	SW-0877
S551	SW-0877
S552	SW-0877
S553	SW-0922

FC550	WF-387 3-70-3 7P (1/2)
FC551	WF-387 3-70-3 7P (1/2)
FC552	WF-387 3-70-3 7P (1/2)
FC553	WF-387 3-70-3 7P (1/2)

DESIGN. BY	DRAWN. BY	UNIDEN NO.	MODEL NO.
YUI	YITO	UT387ZK	TEDDY ASC
DATE	DATE	TITLE	
'11/6/17	'11/08/10	FRONT ASS'Y	
CHECK. BY	APPRO. BY	PARTS ASS'Y TOP VIEW	
YITO	KUNIMITSU	DRAWING NO.	
'11/08/10	'11/08/10	E24-31409	
REV. NO.			UNIDEN CORP.

USE Pb FREE SOLDER

B550 PA-0471AA 2/4 (BOTTOM VIEW)

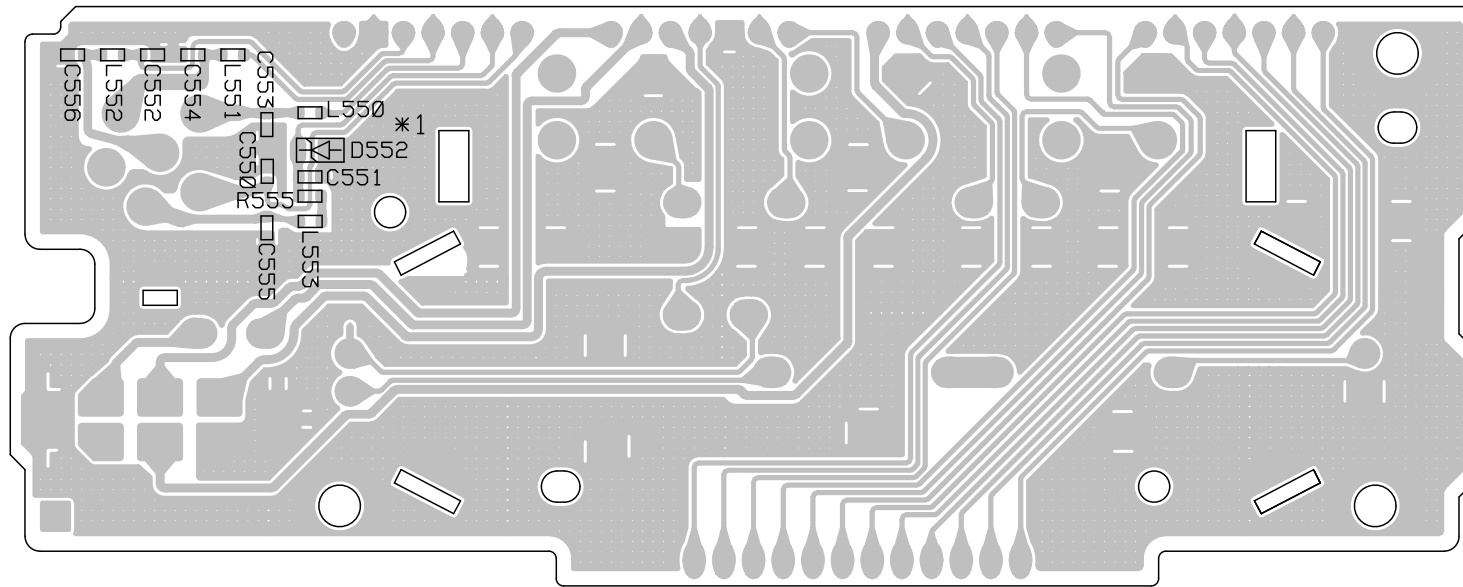

*1 DIRECTION



C550	0.001 K B 50V 1608
C551	0.01 K B 50V 1608
C552	0.01 K B 50V 1608
C553	0.01 K B 50V 1608
C554	0.01 K B 50V 1608
C555	0.01 K B 50V 1608
C556	0.01 K B 50V 1608

R555	100 J 1/16W 1608
------	------------------

D552	HZK6C
------	-------

L550	LZ-207 MMZ1608Y601BT
L551	LZ-207 MMZ1608Y601BT
L552	LZ-207 MMZ1608Y601BT
L553	LZ-207 MMZ1608Y601BT

NOTES:

1. RESISTANCE VALUES ARE SHOWN IN OHMS UNLESS OTHERWISE NOTED. (K=KILO OHM, M=MEG OHM)
2. CAPACITANCE VALUES ARE INDICATED IN MICRO FARADS UNLESS OTHERWISE NOTED. (P=MICRO-MICRO FARAD)

DESIGN. BY	DRAWN. BY	UNIDEN NO.	MODEL NO.
YUI	YITO	UT387ZK	TEDDY ASC
*11/6/17	*11/08/10	TITLE FRONT ASS'Y	
CHECK. BY	APPRO. BY	CHIP LAYOUT BOTTOM VIEW	
YITO	KUNIMITSU	DRAWING NO.	
*11/08/10	*11/08/10	E24-31410	
REV. NO.		UNIDEN CORP.	

TEDDY ASC

COMPONENTS LIST

COMPONENTS LIST

MODEL	TEDDY ASC			
ASSY CODE	PARTS CODE	DESCRIPTION	SPEC	REF NO
AT387ZKBAE	BCHL111016G	C:ELECTROLYTIC	100UF 10V M C-411	C104
AT387ZKBAE	BCHL111016G	C:ELECTROLYTIC	100UF 10V M C-411	C113
AT387ZKBAE	BCHL111016G	C:ELECTROLYTIC	100UF 10V M C-411	C314
AT387ZKBAE	BCHL111026G	C:ELECTROLYTIC	1000UF 10V M C-411	C317
AT387ZKBAE	BCHL112216G	C:ELECTROLYTIC	220UF 10V M C-411	C291
AT387ZKBAE	BCHL112216G	C:ELECTROLYTIC	220UF 10V M C-411	C334
AT387ZKBAE	BCHL114716G	C:ELECTROLYTIC	470UF 10V M C-411	C278
AT387ZKBAE	BCHL314716G	C:ELECTROLYTIC	470UF 16V M C-411	C100
AT387ZKBAE	BCHL514706G	C:ELECTROLYTIC	47UF 25V M C-411	C003
AT387ZKBAE	BCHL514706G	C:ELECTROLYTIC	47UF 25V M C-411	C012
AT387ZKBAE	BCHL514706G	C:ELECTROLYTIC	47UF 25V M C-411	C103
AT387ZKBAE	BCHL514706G	C:ELECTROLYTIC	47UF 25V M C-411	C241
AT387ZKBAE	BCJ812286G	C:ELECTROLYTIC	0.22UF 50V M C-437	C366
AT387ZKBAE	BCJ812296G	C:ELECTROLYTIC	2.2UF 50V M C-437	C367
AT387ZKBAE	BCJW511026G	C:ELECTROLYTIC	1000UF 25V M C-440	C304
AT387ZKBAE	BCML111055G	C:CERAMIC M/L (1608) TAPE	1UF 10V K B	C050
AT387ZKBAE	BCML112295G	C:CERAMIC M/L (1608) TAPE	2.2UF 10V K B	C358
AT387ZKBAE	BCML311045G	C:CERAMIC M/L (1608) TAPE	0.1UF 16V K B	C011
AT387ZKBAE	BCML311045G	C:CERAMIC M/L (1608) TAPE	0.1UF 16V K B	C031
AT387ZKBAE	BCML311045G	C:CERAMIC M/L (1608) TAPE	0.1UF 16V K B	C032
AT387ZKBAE	BCML311045G	C:CERAMIC M/L (1608) TAPE	0.1UF 16V K B	C033
AT387ZKBAE	BCML311045G	C:CERAMIC M/L (1608) TAPE	0.1UF 16V K B	C034
AT387ZKBAE	BCML311045G	C:CERAMIC M/L (1608) TAPE	0.1UF 16V K B	C036
AT387ZKBAE	BCML311045G	C:CERAMIC M/L (1608) TAPE	0.1UF 16V K B	C037
AT387ZKBAE	BCML311045G	C:CERAMIC M/L (1608) TAPE	0.1UF 16V K B	C040
AT387ZKBAE	BCML311045G	C:CERAMIC M/L (1608) TAPE	0.1UF 16V K B	C041
AT387ZKBAE	BCML311045G	C:CERAMIC M/L (1608) TAPE	0.1UF 16V K B	C047
AT387ZKBAE	BCML311045G	C:CERAMIC M/L (1608) TAPE	0.1UF 16V K B	C055
AT387ZKBAE	BCML311045G	C:CERAMIC M/L (1608) TAPE	0.1UF 16V K B	C082
AT387ZKBAE	BCML311045G	C:CERAMIC M/L (1608) TAPE	0.1UF 16V K B	C101
AT387ZKBAE	BCML311045G	C:CERAMIC M/L (1608) TAPE	0.1UF 16V K B	C102
AT387ZKBAE	BCML311045G	C:CERAMIC M/L (1608) TAPE	0.1UF 16V K B	C106
AT387ZKBAE	BCML311045G	C:CERAMIC M/L (1608) TAPE	0.1UF 16V K B	C114
AT387ZKBAE	BCML311045G	C:CERAMIC M/L (1608) TAPE	0.1UF 16V K B	C115
AT387ZKBAE	BCML311045G	C:CERAMIC M/L (1608) TAPE	0.1UF 16V K B	C116
AT387ZKBAE	BCML311045G	C:CERAMIC M/L (1608) TAPE	0.1UF 16V K B	C125
AT387ZKBAE	BCML311045G	C:CERAMIC M/L (1608) TAPE	0.1UF 16V K B	C126

AT387ZKBAE	BCML811035G	C:CERAMIC M/L (1608) TAPE	0.01UF 50V K B	C027
AT387ZKBAE	BCML811035G	C:CERAMIC M/L (1608) TAPE	0.01UF 50V K B	C026
AT387ZKBAE	BCML811035G	C:CERAMIC M/L (1608) TAPE	0.01UF 50V K B	C025
AT387ZKBAE	BCML811035G	C:CERAMIC M/L (1608) TAPE	0.01UF 50V K B	C024
AT387ZKBAE	BCML811035G	C:CERAMIC M/L (1608) TAPE	0.01UF 50V K B	C342
AT387ZKBAE	BCML811035G	C:CERAMIC M/L (1608) TAPE	0.01UF 50V K B	C335
AT387ZKBAE	BCML811035G	C:CERAMIC M/L (1608) TAPE	0.01UF 50V K B	C333
AT387ZKBAE	BCML811035G	C:CERAMIC M/L (1608) TAPE	0.01UF 50V K B	C332
AT387ZKBAE	BCML811035G	C:CERAMIC M/L (1608) TAPE	0.01UF 50V K B	C331
AT387ZKBAE	BCML811035G	C:CERAMIC M/L (1608) TAPE	0.01UF 50V K B	C318
AT387ZKBAE	BCML811035G	C:CERAMIC M/L (1608) TAPE	0.01UF 50V K B	C310
AT387ZKBAE	BCML811035G	C:CERAMIC M/L (1608) TAPE	0.01UF 50V K B	C300
AT387ZKBAE	BCML811035G	C:CERAMIC M/L (1608) TAPE	0.01UF 50V K B	C290
AT387ZKBAE	BCML811035G	C:CERAMIC M/L (1608) TAPE	0.01UF 50V K B	C261
AT387ZKBAE	BCML811035G	C:CERAMIC M/L (1608) TAPE	0.01UF 50V K B	C242
AT387ZKBAE	BCML811035G	C:CERAMIC M/L (1608) TAPE	0.01UF 50V K B	C240
AT387ZKBAE	BCML811035G	C:CERAMIC M/L (1608) TAPE	0.01UF 50V K B	C234
AT387ZKBAE	BCML811035G	C:CERAMIC M/L (1608) TAPE	0.01UF 50V K B	C230
AT387ZKBAE	BCML811035G	C:CERAMIC M/L (1608) TAPE	0.01UF 50V K B	C228
AT387ZKBAE	BCML811035G	C:CERAMIC M/L (1608) TAPE	0.01UF 50V K B	C223
AT387ZKBAE	BCML811035G	C:CERAMIC M/L (1608) TAPE	0.01UF 50V K B	C222
AT387ZKBAE	BCML811035G	C:CERAMIC M/L (1608) TAPE	0.01UF 50V K B	C017
AT387ZKBAE	BCML811035G	C:CERAMIC M/L (1608) TAPE	0.01UF 50V K B	C005
AT387ZKBAE	BCML811035G	C:CERAMIC M/L (1608) TAPE	0.01UF 50V K B	C013
AT387ZKBAE	BCML811035G	C:CERAMIC M/L (1608) TAPE	0.01UF 50V K B	C015
AT387ZKBAE	BCML811035G	C:CERAMIC M/L (1608) TAPE	0.01UF 50V K B	C016
AT387ZKBAE	BCML811035G	C:CERAMIC M/L (1608) TAPE	0.01UF 50V K B	C010
AT387ZKBAE	BCML812235G	C:CERAMIC M/L (1608) TAPE	0.022UF 50V K B	C311
AT387ZKBAE	BCML814725G	C:CERAMIC M/L (1608) TAPE	0.0047UF 50V K B	C105
AT387ZKBAE	BCML814725G	C:CERAMIC M/L (1608) TAPE	0.0047UF 50V K B	C365
AT387ZKBAE	BCML814725G	C:CERAMIC M/L (1608) TAPE	0.0047UF 50V K B	C111
AT387ZKBAE	BCML814735G	C:CERAMIC M/L (1608) TAPE	0.047UF 50V K B	C051
AT387ZKBAE	BCML814735G	C:CERAMIC M/L (1608) TAPE	0.047UF 50V K B	C143
AT387ZKBAE	BCML814735G	C:CERAMIC M/L (1608) TAPE	0.047UF 50V K B	C112
AT387ZKBAE	BCML901055G	C:CERAMIC M/L (1608) TAPE	1UF 6.3V K B	C014
AT387ZKBAE	BCML901055G	C:CERAMIC M/L (1608) TAPE	1UF 6.3V K B	C045
AT387ZKBAE	BCML901055G	C:CERAMIC M/L (1608) TAPE	1UF 6.3V K B	C052
AT387ZKBAE	BCML901055G	C:CERAMIC M/L (1608) TAPE	1UF 6.3V K B	C279
AT387ZKBAE	BCML901055G	C:CERAMIC M/L (1608) TAPE	1UF 6.3V K B	C273
AT387ZKBAE	BCML901055G	C:CERAMIC M/L (1608) TAPE	1UF 6.3V K B	C131
AT387ZKBAE	BCML901055G	C:CERAMIC M/L (1608) TAPE	1UF 6.3V K B	C130
AT387ZKBAE	BCML901055G	C:CERAMIC M/L (1608) TAPE	1UF 6.3V K B	C081
AT387ZKBAE	BCMM811002G	C:CERAMIC M/L (1608) TAPE	10PF 50V D CH	C355
AT387ZKBAE	BCMM811014G	C:CERAMIC M/L (1608) TAPE	100PF 50V J CH	C200
AT387ZKBAE	BCMM811014G	C:CERAMIC M/L (1608) TAPE	100PF 50V J CH	C210

AT387ZKBAE	BCMM811014G	C:CERAMIC M/L (1608) TAPE	100PF 50V J CH	C360
AT387ZKBAE	BCMM811014G	C:CERAMIC M/L (1608) TAPE	100PF 50V J CH	C226
AT387ZKBAE	BCMM811014G	C:CERAMIC M/L (1608) TAPE	100PF 50V J CH	C214
AT387ZKBAE	BCMM811014G	C:CERAMIC M/L (1608) TAPE	100PF 50V J CH	C213
AT387ZKBAE	BCMM811504G	C:CERAMIC M/L (1608) TAPE	15PF 50V J CH	C206
AT387ZKBAE	BCMM811504G	C:CERAMIC M/L (1608) TAPE	15PF 50V J CH	C225
AT387ZKBAE	BCMM811514G	C:CERAMIC M/L (1608) TAPE	150PF 50V J CH	C205
AT387ZKBAE	BCMM811514G	C:CERAMIC M/L (1608) TAPE	150PF 50V J CH	C337
AT387ZKBAE	BCMM811514G	C:CERAMIC M/L (1608) TAPE	150PF 50V J CH	C340
AT387ZKBAE	BCMM811804G	C:CERAMIC M/L (1608) TAPE	18PF 50V J CH	C001
AT387ZKBAE	BCMM811804G	C:CERAMIC M/L (1608) TAPE	18PF 50V J CH	C203
AT387ZKBAE	BCMM811814G	C:CERAMIC M/L (1608) TAPE	180PF 50V J CH	C202
AT387ZKBAE	BCMM811814G	C:CERAMIC M/L (1608) TAPE	180PF 50V J CH	C204
AT387ZKBAE	BCMM812098G	C: CERAMIC M/L (1608) TAPE	2PF 50V B CH	C215
AT387ZKBAE	BCMM812204G	C:CERAMIC M/L (1608) TAPE	22PF 50V J CH	C301
AT387ZKBAE	BCMM812204G	C:CERAMIC M/L (1608) TAPE	22PF 50V J CH	C302
AT387ZKBAE	BCMM812204G	C:CERAMIC M/L (1608) TAPE	22PF 50V J CH	C341
AT387ZKBAE	BCMM812214G	C:CERAMIC M/L (1608) TAPE	220PF 50V J CH	C044
AT387ZKBAE	BCMM812214G	C:CERAMIC M/L (1608) TAPE	220PF 50V J CH	C235
AT387ZKBAE	BCMM812214G	C:CERAMIC M/L (1608) TAPE	220PF 50V J CH	C352
AT387ZKBAE	BCMM812214G	C:CERAMIC M/L (1608) TAPE	220PF 50V J CH	C048
AT387ZKBAE	BCMM812704G	C:CERAMIC M/L (1608) TAPE	27PF 50V J CH	C021
AT387ZKBAE	BCMM812704G	C:CERAMIC M/L (1608) TAPE	27PF 50V J CH	C227
AT387ZKBAE	BCMM812704G	C:CERAMIC M/L (1608) TAPE	27PF 50V J CH	C236
AT387ZKBAE	BCMM812714G	C:CERAMIC M/L (1608) TAPE	270PF 50V J CH	C122
AT387ZKBAE	BCMM812714G	C:CERAMIC M/L (1608) TAPE	270PF 50V J CH	C124
AT387ZKBAE	BCMM813098G	C: CERAMIC M/L (1608) TAPE	3PF 50V B CH	C020
AT387ZKBAE	BCMM813304G	C:CERAMIC M/L (1608) TAPE	33PF 50V J CH	C330
AT387ZKBAE	BCMM813304G	C:CERAMIC M/L (1608) TAPE	33PF 50V J CH	C347
AT387ZKBAE	BCMM813304G	C:CERAMIC M/L (1608) TAPE	33PF 50V J CH	C350
AT387ZKBAE	BCMM813304G	C:CERAMIC M/L (1608) TAPE	33PF 50V J CH	C348
AT387ZKBAE	BCMM813304G	C:CERAMIC M/L (1608) TAPE	33PF 50V J CH	C351
AT387ZKBAE	BCMM813314G	C:CERAMIC M/L (1608) TAPE	330PF 50V J CH	C224
AT387ZKBAE	BCMM813314G	C:CERAMIC M/L (1608) TAPE	330PF 50V J CH	C272
AT387ZKBAE	BCMM813904G	C:CERAMIC M/L (1608) TAPE	39PF 50V J CH	C007
AT387ZKBAE	BCMM813904G	C:CERAMIC M/L (1608) TAPE	39PF 50V J CH	C361
AT387ZKBAE	BCMM814704G	C:CERAMIC M/L (1608) TAPE	47PF 50V J CH	C042
AT387ZKBAE	BCMM814704G	C:CERAMIC M/L (1608) TAPE	47PF 50V J CH	C270
AT387ZKBAE	BCMM814714G	C:CERAMIC M/L (1608) TAPE	470PF 50V J CH	C043
AT387ZKBAE	BCMM814714G	C:CERAMIC M/L (1608) TAPE	470PF 50V J CH	C120
AT387ZKBAE	BCMM814714G	C:CERAMIC M/L (1608) TAPE	470PF 50V J CH	C123
AT387ZKBAE	BCMM814714G	C:CERAMIC M/L (1608) TAPE	470PF 50V J CH	C121
AT387ZKBAE	BCMM815091G	C: CERAMIC M/L (1608) TAPE	5PF 50V C CH	C336
AT387ZKBAE	BCMM815098G	C: CERAMIC M/L (1608) TAPE	5PF 50V B CH	C364
AT387ZKBAE	BCMM815604G	C:CERAMIC M/L (1608) TAPE	56PF 50V J CH	C220
AT387ZKBAE	BCMM816092G	C:CERAMIC M/L (1608) TAPE	6PF 50V D CH	C356
AT387ZKBAE	BCMM816814G	C:CERAMIC M/L (1608) TAPE	680PF 50V J CH	C046

AT387ZKBAE	BCMM816814G	C:CERAMIC M/L (1608) TAPE	680PF 50V J CH	C211
AT387ZKBAE	BCMM816814G	C:CERAMIC M/L (1608) TAPE	680PF 50V J CH	C212
AT387ZKBAE	BCMM817092G	C: CERAMIC M/L (1608) TAPE	7PF 50V D CH	C030
AT387ZKBAE	BCMM817092G	C: CERAMIC M/L (1608) TAPE	7PF 50V D CH	C363
AT387ZKBAE	BCMM817092G	C: CERAMIC M/L (1608) TAPE	7PF 50V D CH	C362
AT387ZKBAE	BCMM818204G	C:CERAMIC M/L (1608) TAPE	82PF 50V J CH	C232
AT387ZKBAE	BCMM818214G	C:CERAMIC M/L (1608) TAPE	820PF 50V J CH	C271
AT387ZKBAE	BDAG1268001	DIODE	KDS226-RTK/P	D120
AT387ZKBAE	BDAG1269001	DIODE	KDS114E-RTK/P	D001
AT387ZKBAE	BDAG1269001	DIODE	KDS114E-RTK/P	D011
AT387ZKBAE	BDAG1269001	DIODE	KDS114E-RTK/P	D002
AT387ZKBAE	BDAG1270001	DIODE	KDS160E-RTK/P	D200
AT387ZKBAE	BDAG1280001	DIODE:VARICAP	HVU307 TRU-E	D140
AT387ZKBAE	BDAG1280001	DIODE:VARICAP	HVU307 TRU-E	D361
AT387ZKBAE	BDAG1280001	DIODE:VARICAP	HVU307 TRU-E	D350
AT387ZKBAE	BDAG1280001	DIODE:VARICAP	HVU307 TRU-E	D360
AT387ZKBAE	BDAG1355001	DIODE	SDB30A40	D150
AT387ZKBAE	BDAG1414001	DIODE	DA-1414 LL34LL4148	D003
AT387ZKBAE	BDAG1414001	DIODE	DA-1414 LL34LL4148	D005
AT387ZKBAE	BDAG1414001	DIODE	DA-1414 LL34LL4148	D006
AT387ZKBAE	BDAG1414001	DIODE	DA-1414 LL34LL4148	D121
AT387ZKBAE	BDAG1414001	DIODE	DA-1414 LL34LL4148	D242
AT387ZKBAE	BDAG1414001	DIODE	DA-1414 LL34LL4148	D290
AT387ZKBAE	BDAG1414001	DIODE	DA-1414 LL34LL4148	D240
AT387ZKBAE	BDAG1414001	DIODE	DA-1414 LL34LL4148	D007
AT387ZKBAE	BDAG1414001	DIODE	DA-1414 LL34LL4148	D004
AT387ZKBAE	BDAG1423004	DIODE:ZENER	HZK6C	D300
AT387ZKBAE	BDAG1572016	DIODE:ZENER	MM3Z3V0B	D291
AT387ZKBAE	BDAG1590001	DIODE	BAR43S	D010
AT387ZKBAE	BDAG1629001	DIODE	1N4003	D241
AT387ZKBAE	BDBL2314106	TRANSISTOR	DB-792 2SC2314F	Q220
AT387ZKBAE	BDBL4226646	TRANSISTOR	DB-1174 2SC4226-R24 T1	Q330
AT387ZKBAE	BDBL4226646	TRANSISTOR	DB-1174 2SC4226-R24 T1	Q331
AT387ZKBAE	BDBL4226646	TRANSISTOR	DB-1174 2SC4226-R24 T1	Q340
AT387ZKBAE	BDBM2114000	TRANSISTOR	DB-1300 2SD2114K	Q007
AT387ZKBAE	BDBM2114000	TRANSISTOR	DB-1300 2SD2114K	Q291
AT387ZKBAE	BDBM2114000	TRANSISTOR	DB-1300 2SD2114K	Q332
AT387ZKBAE	BDBM2114000	TRANSISTOR	DB-1300 2SD2114K	Q012
AT387ZKBAE	BDBN1259001	TRANSISTOR	DB-1259 KTC3875S-GR-RTK/P TAPE	Q005
AT387ZKBAE	BDBN1259001	TRANSISTOR	DB-1259 KTC3875S-GR-RTK/P TAPE	Q120
AT387ZKBAE	BDBN1259001	TRANSISTOR	DB-1259 KTC3875S-GR-RTK/P TAPE	Q224
AT387ZKBAE	BDBN1259001	TRANSISTOR	DB-1259 KTC3875S-GR-RTK/P TAPE	Q280
AT387ZKBAE	BDBN1259001	TRANSISTOR	DB-1259 KTC3875S-GR-RTK/P	Q260

			TAPE	
AT387ZKBAE	BDBN1259001	TRANSISTOR	DB-1259 KTC3875S-GR-RTK/P TAPE	Q140
AT387ZKBAE	BDBN1259001	TRANSISTOR	DB-1259 KTC3875S-GR-RTK/P TAPE	Q100
AT387ZKBAE	BDBN1259001	TRANSISTOR	DB-1259 KTC3875S-GR-RTK/P TAPE	Q006
AT387ZKBAE	BDBN1259001	TRANSISTOR	DB-1259 KTC3875S-GR-RTK/P TAPE	Q010
AT387ZKBAE	BDBN1259001	TRANSISTOR	DB-1259 KTC3875S-GR-RTK/P TAPE	Q090
AT387ZKBAE	BDBN1259001	TRANSISTOR	DB-1259 KTC3875S-GR-RTK/P TAPE	Q011
AT387ZKBAE	BDBN1290001	TRANSISTOR	DB-1290 LMBT3906LT1G	Q223
AT387ZKBAE	BDBN1290001	TRANSISTOR	DB-1290 LMBT3906LT1G	Q290
AT387ZKBAE	BDBN1290001	TRANSISTOR	DB-1290 LMBT3906LT1G	Q241
AT387ZKBAE	BDBN1326001	TRANSISTOR	DB-1326 MMBTSC2714Y	Q001
AT387ZKBAE	BDBN1326001	TRANSISTOR	DB-1326 MMBTSC2714Y	Q350
AT387ZKBAE	BDBN1326001	TRANSISTOR	DB-1326 MMBTSC2714Y	Q004
AT387ZKBAE	BDBN1326001	TRANSISTOR	DB-1326 MMBTSC2714Y	Q222
AT387ZKBAE	BDBN1330001	TRANSISTOR	DB-1330 KTC3209-Y-AT/P	Q240
AT387ZKBAE	BDBN1332001	TRANSISTOR	DB-1332 KTA1725-O-U/P	Q242
AT387ZKBAE	BDBN1340001	TRANSISTOR	DB-1340 ST2SC3202-Y	Q221
AT387ZKBAE	BDCN0355001	FIELD EFFECT TRANSISTOR	DC-355 MMBFJ309LT1G	Q002
AT387ZKBAE	BDCN0355001	FIELD EFFECT TRANSISTOR	DC-355 MMBFJ309LT1G	Q003
AT387ZKBAE	BDEG4463003	INTEGRATED CIRCUIT	NJM12904R-TE1-#ZZZB	IC080
AT387ZKBAE	BDEG4463003	INTEGRATED CIRCUIT	NJM12904R-TE1-#ZZZB	IC120
AT387ZKBAE	BDEG4463003	INTEGRATED CIRCUIT	NJM12904R-TE1-#ZZZB	IC280
AT387ZKBAE	BDEG4680003	INTEGRATED CIRCUIT	XC6109C43ANR	IC310
AT387ZKBAE	BDEG5165003	INTEGRATED CIRCUIT	MCD2926	IC350
AT387ZKBAE	BDEG5186003	INTEGRATED CIRCUIT	MC3361	IC110
AT387ZKBAE	BDEG5191003	INTEGRATED CIRCUIT	FM24C02A-SO-T-G	IC302
AT387ZKBAE	BDEG5193003	INTEGRATED CIRCUIT	UR6225L-50-AB3-C-R	IC311
AT387ZKBAE	BDEG5194001	INTEGRATED CIRCUIT	TDA2003L-TB5-T	IC111
AT387ZKBAE	BDEG5195001	INTEGRATED CIRCUIT	ST7808	IC301
AT387ZKBAE	BFLG1087001	FILTER:CRYSTAL	FL-1087 10M07AZ	FT001
AT387ZKBAE	BFLG1170001	FILTER:CERAMIC	FL-1170 LTS455HTW	FT002
AT387ZKBAE	BJKG1249003	JACK	JK-1249 IMSA-9210B-1-03Z058-PT1	J300
AT387ZKBAE	BJKG1310001	JACK:EARPHONE	JK-1310 PJ-305C	J002
AT387ZKBAE	BLBG1276001	COIL	LB-1276	L004
AT387ZKBAE	BLBG1285001	COIL	LB-1285	L001
AT387ZKBAE	BLBG1301001	COIL	LB-1301 7DL-C7306-LF	L110
AT387ZKBAE	BLBH1153001	COIL	LB-1153 KS2485NC	L002
AT387ZKBAE	BLBH1239001	COIL	LB-1239 KS2585N	L003
AT387ZKBAE	BLBH1272001	COIL	LB-1272 7MK4A035A	L005
AT387ZKBAE	BLBH1272001	COIL	LB-1272 7MK4A035A	L007
AT387ZKBAE	BLEG0600001	COIL	LE-0600	L205

AT387ZKBAE	BLEH0475001	COIL	LE-475 SZFDLLE-475	L201
AT387ZKBAE	BLEH0475001	COIL	LE-475 SZFDLLE-475	L204
AT387ZKBAE	BLEH0475001	COIL	LE-475 SZFDLLE-475	L220
AT387ZKBAE	BLEH0475001	COIL	LE-475 SZFDLLE-475	L203
AT387ZKBAE	BLEH0475001	COIL	LE-475 SZFDLLE-475	L202
AT387ZKBAE	BLZG0194221	INDUCTOR:MOLDED CHIP	LZ-194 MPZ2012S221AT 220	L010
AT387ZKBAE	BLZG0194221	INDUCTOR:MOLDED CHIP	LZ-194 MPZ2012S221AT 220	L150
AT387ZKBAE	BLZG0194221	INDUCTOR:MOLDED CHIP	LZ-194 MPZ2012S221AT 220	L151
AT387ZKBAE	BLZG0194221	INDUCTOR:MOLDED CHIP	LZ-194 MPZ2012S221AT 220	L221
AT387ZKBAE	BLZG0194221	INDUCTOR:MOLDED CHIP	LZ-194 MPZ2012S221AT 220	L223
AT387ZKBAE	BLZG0194221	INDUCTOR:MOLDED CHIP	LZ-194 MPZ2012S221AT 220	L011
AT387ZKBAE	BLZG0226100	INDUCTOR:MOLDED CHIP	LZ-226 SGM1608K100K T	L006
AT387ZKBAE	BLZG0226108	INDUCTOR:MOLDED CHIP	LZ-226 SGM1608GR10K T	L340
AT387ZKBAE	BLZG0226108	INDUCTOR:MOLDED CHIP	LZ-226 SGM1608GR10K T	L341
AT387ZKBAE	BLZG0236478	INDUCTOR:MOLDED CHIP	LZ-236 SGHI2012 0.47UH	L224
AT387ZKBAE	BLZG0267188	INDUCTOR:MOLDED CHIP	LZ-267 NLV25T-R18J-PF	L222
AT387ZKBAE	BLZG0373338	INDUCTOR:MOLDED CHIP	LZ-373 SDWL2012CR33JSTF	L331
AT387ZKBAE	BLZG0373398	INDUCTOR:MOLDED CHIP	LZ-373 SDWL2012CR39JSTF	L330
AT387ZKBAE	BPAG0471AA1	PCB:MAIN	PA-471AA 1/4	B001
AT387ZKBAE	BPGG0185001	PLUG	PG-185 IMSA-9215H-T	PG300
AT387ZKBAE	BQXG0975001	CRYSTAL	QX-975 10.24MHZ	X350
AT387ZKBAE	BQXG0982001	CRYSTAL	QX-982 3.6864MHZ	X300
AT387ZKBAE	BRFC121014G	R:CARBON FIXED CHIP(5025)	100 1/2W J TAPE	R246
AT387ZKBAE	BRFC128204G	R:CARBON FIXED CHIP(5025)	82 1/2W J TAPE	R245
AT387ZKBAE	BRFC160004G	R:CARBON FIXED CHIP(1608)	0 1/16W J TAPE	R002
AT387ZKBAE	BRFC160004G	R:CARBON FIXED CHIP(1608)	0 1/16W J TAPE	R119
AT387ZKBAE	BRFC160004G	R:CARBON FIXED CHIP(1608)	0 1/16W J TAPE	R135
AT387ZKBAE	BRFC160004G	R:CARBON FIXED CHIP(1608)	0 1/16W J TAPE	R138
AT387ZKBAE	BRFC160004G	R:CARBON FIXED CHIP(1608)	0 1/16W J TAPE	R145
AT387ZKBAE	BRFC160004G	R:CARBON FIXED CHIP(1608)	0 1/16W J TAPE	R204
AT387ZKBAE	BRFC160004G	R:CARBON FIXED CHIP(1608)	0 1/16W J TAPE	R385
AT387ZKBAE	BRFC160004G	R:CARBON FIXED CHIP(1608)	0 1/16W J TAPE	R383
AT387ZKBAE	BRFC160004G	R:CARBON FIXED CHIP(1608)	0 1/16W J TAPE	R320
AT387ZKBAE	BRFC160004G	R:CARBON FIXED CHIP(1608)	0 1/16W J TAPE	R262
AT387ZKBAE	BRFC160004G	R:CARBON FIXED CHIP(1608)	0 1/16W J TAPE	R218
AT387ZKBAE	BRFC160004G	R:CARBON FIXED CHIP(1608)	0 1/16W J TAPE	R211
AT387ZKBAE	BRFC160004G	R:CARBON FIXED CHIP(1608)	0 1/16W J TAPE	R210
AT387ZKBAE	BRFC160004G	R:CARBON FIXED CHIP(1608)	0 1/16W J TAPE	R209
AT387ZKBAE	BRFC160004G	R:CARBON FIXED CHIP(1608)	0 1/16W J TAPE	R208
AT387ZKBAE	BRFC160004G	R:CARBON FIXED CHIP(1608)	0 1/16W J TAPE	R206
AT387ZKBAE	BRFC160004G	R:CARBON FIXED CHIP(1608)	0 1/16W J TAPE	R205
AT387ZKBAE	BRFC160004G	R:CARBON FIXED CHIP(1608)	0 1/16W J TAPE	R358
AT387ZKBAE	BRFC160004G	R:CARBON FIXED CHIP(1608)	0 1/16W J TAPE	R357
AT387ZKBAE	BRFC160004G	R:CARBON FIXED CHIP(1608)	0 1/16W J TAPE	R349
AT387ZKBAE	BRFC160004G	R:CARBON FIXED CHIP(1608)	0 1/16W J TAPE	R328
AT387ZKBAE	BRFC160004G	R:CARBON FIXED CHIP(1608)	0 1/16W J TAPE	R326
AT387ZKBAE	BRFC160004G	R:CARBON FIXED CHIP(1608)	0 1/16W J TAPE	R324

AT387ZKBAE	BRFC161054G	R:CARBON FIXED CHIP(1608)	1M 1/16W J TAPE	R282
AT387ZKBAE	BRFC161054G	R:CARBON FIXED CHIP(1608)	1M 1/16W J TAPE	R325
AT387ZKBAE	BRFC161054G	R:CARBON FIXED CHIP(1608)	1M 1/16W J TAPE	R280
AT387ZKBAE	BRFC161504G	R:CARBON FIXED CHIP(1608)	15 1/16W J TAPE	R227
AT387ZKBAE	BRFC161524G	R:CARBON FIXED CHIP(1608)	1.5K 1/16W J TAPE	R003
AT387ZKBAE	BRFC161524G	R:CARBON FIXED CHIP(1608)	1.5K 1/16W J TAPE	R104
AT387ZKBAE	BRFC161524G	R:CARBON FIXED CHIP(1608)	1.5K 1/16W J TAPE	R200
AT387ZKBAE	BRFC161524G	R:CARBON FIXED CHIP(1608)	1.5K 1/16W J TAPE	R361
AT387ZKBAE	BRFC161524G	R:CARBON FIXED CHIP(1608)	1.5K 1/16W J TAPE	R365
AT387ZKBAE	BRFC161524G	R:CARBON FIXED CHIP(1608)	1.5K 1/16W J TAPE	R264
AT387ZKBAE	BRFC161524G	R:CARBON FIXED CHIP(1608)	1.5K 1/16W J TAPE	R148
AT387ZKBAE	BRFC161524G	R:CARBON FIXED CHIP(1608)	1.5K 1/16W J TAPE	R035
AT387ZKBAE	BRFC161524G	R:CARBON FIXED CHIP(1608)	1.5K 1/16W J TAPE	R004
AT387ZKBAE	BRFC161524G	R:CARBON FIXED CHIP(1608)	1.5K 1/16W J TAPE	R008
AT387ZKBAE	BRFC161524G	R:CARBON FIXED CHIP(1608)	1.5K 1/16W J TAPE	R009
AT387ZKBAE	BRFC161534G	R:CARBON FIXED CHIP(1608)	15K 1/16W J TAPE	R037
AT387ZKBAE	BRFC161544G	R:CARBON FIXED CHIP(1608)	150K 1/16W J TAPE	R085
AT387ZKBAE	BRFC161544G	R:CARBON FIXED CHIP(1608)	150K 1/16W J TAPE	R088
AT387ZKBAE	BRFC161824G	R:CARBON FIXED CHIP(1608)	1.8K 1/16W J TAPE	R225
AT387ZKBAE	BRFC161824G	R:CARBON FIXED CHIP(1608)	1.8K 1/16W J TAPE	R242
AT387ZKBAE	BRFC161824G	R:CARBON FIXED CHIP(1608)	1.8K 1/16W J TAPE	R241
AT387ZKBAE	BRFC161834G	R:CARBON FIXED CHIP(1608)	18K 1/16W J TAPE	R076
AT387ZKBAE	BRFC161834G	R:CARBON FIXED CHIP(1608)	18K 1/16W J TAPE	R263
AT387ZKBAE	BRFC162204G	R:CARBON FIXED CHIP(1608)	22 1/16W J TAPE	R046
AT387ZKBAE	BRFC162214G	R:CARBON FIXED CHIP(1608)	220 1/16W J TAPE	R024
AT387ZKBAE	BRFC162214G	R:CARBON FIXED CHIP(1608)	220 1/16W J TAPE	R043
AT387ZKBAE	BRFC162214G	R:CARBON FIXED CHIP(1608)	220 1/16W J TAPE	R130
AT387ZKBAE	BRFC162214G	R:CARBON FIXED CHIP(1608)	220 1/16W J TAPE	R234
AT387ZKBAE	BRFC162214G	R:CARBON FIXED CHIP(1608)	220 1/16W J TAPE	R333
AT387ZKBAE	BRFC162214G	R:CARBON FIXED CHIP(1608)	220 1/16W J TAPE	R338
AT387ZKBAE	BRFC162214G	R:CARBON FIXED CHIP(1608)	220 1/16W J TAPE	R340
AT387ZKBAE	BRFC162214G	R:CARBON FIXED CHIP(1608)	220 1/16W J TAPE	R337
AT387ZKBAE	BRFC162214G	R:CARBON FIXED CHIP(1608)	220 1/16W J TAPE	R294
AT387ZKBAE	BRFC162214G	R:CARBON FIXED CHIP(1608)	220 1/16W J TAPE	R230
AT387ZKBAE	BRFC162214G	R:CARBON FIXED CHIP(1608)	220 1/16W J TAPE	R034
AT387ZKBAE	BRFC162224G	R:CARBON FIXED CHIP(1608)	2.2K 1/16W J TAPE	R001
AT387ZKBAE	BRFC162224G	R:CARBON FIXED CHIP(1608)	2.2K 1/16W J TAPE	R075
AT387ZKBAE	BRFC162224G	R:CARBON FIXED CHIP(1608)	2.2K 1/16W J TAPE	R127
AT387ZKBAE	BRFC162224G	R:CARBON FIXED CHIP(1608)	2.2K 1/16W J TAPE	R236
AT387ZKBAE	BRFC162224G	R:CARBON FIXED CHIP(1608)	2.2K 1/16W J TAPE	R276
AT387ZKBAE	BRFC162224G	R:CARBON FIXED CHIP(1608)	2.2K 1/16W J TAPE	R298
AT387ZKBAE	BRFC162224G	R:CARBON FIXED CHIP(1608)	2.2K 1/16W J TAPE	R270
AT387ZKBAE	BRFC162224G	R:CARBON FIXED CHIP(1608)	2.2K 1/16W J TAPE	R141
AT387ZKBAE	BRFC162224G	R:CARBON FIXED CHIP(1608)	2.2K 1/16W J TAPE	R123
AT387ZKBAE	BRFC162224G	R:CARBON FIXED CHIP(1608)	2.2K 1/16W J TAPE	R047
AT387ZKBAE	BRFC162224G	R:CARBON FIXED CHIP(1608)	2.2K 1/16W J TAPE	R006
AT387ZKBAE	BRFC162224G	R:CARBON FIXED CHIP(1608)	2.2K 1/16W J TAPE	R036

AT387ZKBAE	BRFC162234G	R:CARBON FIXED CHIP(1608)	22K 1/16W J TAPE	R341
AT387ZKBAE	BRFC162244G	R:CARBON FIXED CHIP(1608)	220K 1/16W J TAPE	R086
AT387ZKBAE	BRFC162244G	R:CARBON FIXED CHIP(1608)	220K 1/16W J TAPE	R272
AT387ZKBAE	BRFC162244G	R:CARBON FIXED CHIP(1608)	220K 1/16W J TAPE	R273
AT387ZKBAE	BRFC162244G	R:CARBON FIXED CHIP(1608)	220K 1/16W J TAPE	R317
AT387ZKBAE	BRFC162244G	R:CARBON FIXED CHIP(1608)	220K 1/16W J TAPE	R271
AT387ZKBAE	BRFC162294G	R:CARBON FIXED CHIP(1608)	2.2 1/16W J TAPE	R100
AT387ZKBAE	BRFC162714G	R:CARBON FIXED CHIP(1608)	270 1/16W J TAPE	R015
AT387ZKBAE	BRFC162714G	R:CARBON FIXED CHIP(1608)	270 1/16W J TAPE	R018
AT387ZKBAE	BRFC162724G	R:CARBON FIXED CHIP(1608)	2.7K 1/16W J TAPE	R281
AT387ZKBAE	BRFC163304G	R:CARBON FIXED CHIP(1608)	33 1/16W J TAPE	R048
AT387ZKBAE	BRFC163304G	R:CARBON FIXED CHIP(1608)	33 1/16W J TAPE	R220
AT387ZKBAE	BRFC163314G	R:CARBON FIXED CHIP(1608)	330 1/16W J TAPE	R038
AT387ZKBAE	BRFC163314G	R:CARBON FIXED CHIP(1608)	330 1/16W J TAPE	R348
AT387ZKBAE	BRFC163324G	R:CARBON FIXED CHIP(1608)	3.3K 1/16W J TAPE	R026
AT387ZKBAE	BRFC163324G	R:CARBON FIXED CHIP(1608)	3.3K 1/16W J TAPE	R251
AT387ZKBAE	BRFC163324G	R:CARBON FIXED CHIP(1608)	3.3K 1/16W J TAPE	R285
AT387ZKBAE	BRFC163324G	R:CARBON FIXED CHIP(1608)	3.3K 1/16W J TAPE	R379
AT387ZKBAE	BRFC163324G	R:CARBON FIXED CHIP(1608)	3.3K 1/16W J TAPE	R284
AT387ZKBAE	BRFC163324G	R:CARBON FIXED CHIP(1608)	3.3K 1/16W J TAPE	R240
AT387ZKBAE	BRFC163324G	R:CARBON FIXED CHIP(1608)	3.3K 1/16W J TAPE	R041
AT387ZKBAE	BRFC163324G	R:CARBON FIXED CHIP(1608)	3.3K 1/16W J TAPE	R052
AT387ZKBAE	BRFC163324G	R:CARBON FIXED CHIP(1608)	3.3K 1/16W J TAPE	R226
AT387ZKBAE	BRFC163324G	R:CARBON FIXED CHIP(1608)	3.3K 1/16W J TAPE	R084
AT387ZKBAE	BRFC163334G	R:CARBON FIXED CHIP(1608)	33K 1/16W J TAPE	R066
AT387ZKBAE	BRFC163334G	R:CARBON FIXED CHIP(1608)	33K 1/16W J TAPE	R115
AT387ZKBAE	BRFC163334G	R:CARBON FIXED CHIP(1608)	33K 1/16W J TAPE	R128
AT387ZKBAE	BRFC163334G	R:CARBON FIXED CHIP(1608)	33K 1/16W J TAPE	R101
AT387ZKBAE	BRFC163394G	R:CARBON FIXED CHIP(1608)	3.3 1/16W J TAPE	R221
AT387ZKBAE	BRFC163924G	R:CARBON FIXED CHIP(1608)	3.9K 1/16W J TAPE	R120
AT387ZKBAE	BRFC163924G	R:CARBON FIXED CHIP(1608)	3.9K 1/16W J TAPE	R364
AT387ZKBAE	BRFC164704G	R:CARBON FIXED CHIP(1608)	47 1/16W J TAPE	R051
AT387ZKBAE	BRFC164704G	R:CARBON FIXED CHIP(1608)	47 1/16W J TAPE	R102
AT387ZKBAE	BRFC164704G	R:CARBON FIXED CHIP(1608)	47 1/16W J TAPE	R347
AT387ZKBAE	BRFC164704G	R:CARBON FIXED CHIP(1608)	47 1/16W J TAPE	R354
AT387ZKBAE	BRFC164704G	R:CARBON FIXED CHIP(1608)	47 1/16W J TAPE	R355
AT387ZKBAE	BRFC164704G	R:CARBON FIXED CHIP(1608)	47 1/16W J TAPE	R222
AT387ZKBAE	BRFC164714G	R:CARBON FIXED CHIP(1608)	470 1/16W J TAPE	R040
AT387ZKBAE	BRFC164714G	R:CARBON FIXED CHIP(1608)	470 1/16W J TAPE	R068
AT387ZKBAE	BRFC164714G	R:CARBON FIXED CHIP(1608)	470 1/16W J TAPE	R093
AT387ZKBAE	BRFC164724G	R:CARBON FIXED CHIP(1608)	4.7K 1/16W J TAPE	R019
AT387ZKBAE	BRFC164724G	R:CARBON FIXED CHIP(1608)	4.7K 1/16W J TAPE	R382
AT387ZKBAE	BRFC164724G	R:CARBON FIXED CHIP(1608)	4.7K 1/16W J TAPE	R380
AT387ZKBAE	BRFC164724G	R:CARBON FIXED CHIP(1608)	4.7K 1/16W J TAPE	R376
AT387ZKBAE	BRFC164724G	R:CARBON FIXED CHIP(1608)	4.7K 1/16W J TAPE	R362
AT387ZKBAE	BRFC164724G	R:CARBON FIXED CHIP(1608)	4.7K 1/16W J TAPE	R345
AT387ZKBAE	BRFC164724G	R:CARBON FIXED CHIP(1608)	4.7K 1/16W J TAPE	R292

AT387ZKBAE	BRFC164724G	R:CARBON FIXED CHIP(1608)	4.7K 1/16W J TAPE	R071
AT387ZKBAE	BRFC164724G	R:CARBON FIXED CHIP(1608)	4.7K 1/16W J TAPE	R078
AT387ZKBAE	BRFC164724G	R:CARBON FIXED CHIP(1608)	4.7K 1/16W J TAPE	R147
AT387ZKBAE	BRFC164724G	R:CARBON FIXED CHIP(1608)	4.7K 1/16W J TAPE	R283
AT387ZKBAE	BRFC164724G	R:CARBON FIXED CHIP(1608)	4.7K 1/16W J TAPE	R260
AT387ZKBAE	BRFC164724G	R:CARBON FIXED CHIP(1608)	4.7K 1/16W J TAPE	R070
AT387ZKBAE	BRFC164734G	R:CARBON FIXED CHIP(1608)	47K 1/16W J TAPE	R031
AT387ZKBAE	BRFC164734G	R:CARBON FIXED CHIP(1608)	47K 1/16W J TAPE	R081
AT387ZKBAE	BRFC164734G	R:CARBON FIXED CHIP(1608)	47K 1/16W J TAPE	R140
AT387ZKBAE	BRFC164734G	R:CARBON FIXED CHIP(1608)	47K 1/16W J TAPE	R235
AT387ZKBAE	BRFC164734G	R:CARBON FIXED CHIP(1608)	47K 1/16W J TAPE	R353
AT387ZKBAE	BRFC164734G	R:CARBON FIXED CHIP(1608)	47K 1/16W J TAPE	R351
AT387ZKBAE	BRFC164734G	R:CARBON FIXED CHIP(1608)	47K 1/16W J TAPE	R342
AT387ZKBAE	BRFC164734G	R:CARBON FIXED CHIP(1608)	47K 1/16W J TAPE	R334
AT387ZKBAE	BRFC164734G	R:CARBON FIXED CHIP(1608)	47K 1/16W J TAPE	R297
AT387ZKBAE	BRFC164734G	R:CARBON FIXED CHIP(1608)	47K 1/16W J TAPE	R266
AT387ZKBAE	BRFC164734G	R:CARBON FIXED CHIP(1608)	47K 1/16W J TAPE	R261
AT387ZKBAE	BRFC164734G	R:CARBON FIXED CHIP(1608)	47K 1/16W J TAPE	R250
AT387ZKBAE	BRFC164734G	R:CARBON FIXED CHIP(1608)	47K 1/16W J TAPE	R244
AT387ZKBAE	BRFC164734G	R:CARBON FIXED CHIP(1608)	47K 1/16W J TAPE	R224
AT387ZKBAE	BRFC164734G	R:CARBON FIXED CHIP(1608)	47K 1/16W J TAPE	R083
AT387ZKBAE	BRFC164734G	R:CARBON FIXED CHIP(1608)	47K 1/16W J TAPE	R079
AT387ZKBAE	BRFC164734G	R:CARBON FIXED CHIP(1608)	47K 1/16W J TAPE	R045
AT387ZKBAE	BRFC164734G	R:CARBON FIXED CHIP(1608)	47K 1/16W J TAPE	R054
AT387ZKBAE	BRFC164734G	R:CARBON FIXED CHIP(1608)	47K 1/16W J TAPE	R077
AT387ZKBAE	BRFC164744G	R:CARBON FIXED CHIP(1608)	470K 1/16W J TAPE	R061
AT387ZKBAE	BRFC164744G	R:CARBON FIXED CHIP(1608)	470K 1/16W J TAPE	R067
AT387ZKBAE	BRFC164744G	R:CARBON FIXED CHIP(1608)	470K 1/16W J TAPE	R090
AT387ZKBAE	BRFC164794G	R:CARBON FIXED CHIP(1608)	4.7 1/16W J TAPE	R014
AT387ZKBAE	BRFC165604G	R:CARBON FIXED CHIP(1608)	56 1/16W J TAPE	R223
AT387ZKBAE	BRFC165604G	R:CARBON FIXED CHIP(1608)	56 1/16W J TAPE	R231
AT387ZKBAE	BRFC165614G	R:CARBON FIXED CHIP(1608)	560 1/16W J TAPE	R293
AT387ZKBAE	BRFC165634G	R:CARBON FIXED CHIP(1608)	56K 1/16W J TAPE	R233
AT387ZKBAE	BRFC165644G	R:CARBON FIXED CHIP(1608)	560K 1/16W J TAPE	R126
AT387ZKBAE	BRFC165644G	R:CARBON FIXED CHIP(1608)	560K 1/16W J TAPE	R133
AT387ZKBAE	BRFC166814G	R:CARBON FIXED CHIP(1608)	680 1/16W J TAPE	R025
AT387ZKBAE	BRFC166814G	R:CARBON FIXED CHIP(1608)	680 1/16W J TAPE	R114
AT387ZKBAE	BRFC166824G	R:CARBON FIXED CHIP(1608)	6.8K 1/16W J TAPE	R011
AT387ZKBAE	BRFC166824G	R:CARBON FIXED CHIP(1608)	6.8K 1/16W J TAPE	R095
AT387ZKBAE	BRFC166824G	R:CARBON FIXED CHIP(1608)	6.8K 1/16W J TAPE	R352
AT387ZKBAE	BRFC166824G	R:CARBON FIXED CHIP(1608)	6.8K 1/16W J TAPE	R105
AT387ZKBAE	BRFC166824G	R:CARBON FIXED CHIP(1608)	6.8K 1/16W J TAPE	R094
AT387ZKBAE	BRFC166824G	R:CARBON FIXED CHIP(1608)	6.8K 1/16W J TAPE	R012
AT387ZKBAE	BRFC166834G	R:CARBON FIXED CHIP(1608)	68K 1/16W J TAPE	R060
AT387ZKBAE	BRFC166834G	R:CARBON FIXED CHIP(1608)	68K 1/16W J TAPE	R062
AT387ZKBAE	BRFC166844G	R:CARBON FIXED CHIP(1608)	680K 1/16W J TAPE	R122
AT387ZKBAE	BRFC168204G	R:CARBON FIXED CHIP(1608)	82 1/16W J TAPE	R243

AT387ZKBAE	BRFC180004G	R:CARBON FIXED CHIP(3216)	0 1/8W J TAPE	R022
AT387ZKBAE	BRFC180004G	R:CARBON FIXED CHIP(3216)	0 1/8W J TAPE	R023
AT387ZKBAE	BRFC180004G	R:CARBON FIXED CHIP(3216)	0 1/8W J TAPE	R042
AT387ZKBAE	BRFC180004G	R:CARBON FIXED CHIP(3216)	0 1/8W J TAPE	R039
AT387ZKBAE	BRFT141034G	R:CARBON AXIAL LEAD (52)	10K 1/4W J TAPE	R113
AT387ZKBAE	BRFT141034G	R:CARBON AXIAL LEAD (52)	10K 1/4W J TAPE	R363
AT387ZKBAE	BRPA611034G	R:CARBON AXIAL LEAD (26)	10K 1/6W J TAPE	R310
AT387ZKBAE	BRPA611034G	R:CARBON AXIAL LEAD (26)	10K 1/6W J TAPE	R312
AT387ZKBAE	BRPA611034G	R:CARBON AXIAL LEAD (26)	10K 1/6W J TAPE	R313
AT387ZKBAE	BRPA611034G	R:CARBON AXIAL LEAD (26)	10K 1/6W J TAPE	R311
AT387ZKBAE	BRSJ002214G	R:METAL OXIDE	220 1WS J	R228
AT387ZKBAE	BRSJ034794G	R:METAL OXIDE	4.7 3WS J	R059
AT387ZKBAE	BRTG0600501	R:SEMI-FIXED	RT-600 VZ067TL1B501 500B	RT120
AT387ZKBAE	BRTG0600502	R:SEMI-FIXED	RT-600 VZ067TL1B502 5KB	RT080
AT387ZKBAE	BRTG0600502	R:SEMI-FIXED	RT-600 VZ067TL1B502 5KB	RT140
AT387ZKBAE	BRTG0600502	R:SEMI-FIXED	RT-600 VZ067TL1B502 5KB	RT240
AT387ZKBAE	BRTG0600502	R:SEMI-FIXED	RT-600 VZ067TL1B502 5KB	RT241
AT387ZKBAE	BRTG0600502	R:SEMI-FIXED	RT-600 VZ067TL1B502 5KB	RT350
AT387ZKBAE	BRTG0600502	R:SEMI-FIXED	RT-600 VZ067TL1B502 5KB	RT081
AT387ZKBAE	BRTG0600503	R:SEMI-FIXED	RT-600 VZ067TL1B503 50KB	RT260
AT387ZKBAE	BTFG0083001	TRANSFORMER:AF CHOKE	TF-083	T150
AT387ZKBAE	BTFG0577001	TRANS	TF-577	T100
AT387ZKBAE	BTGP0138001	TEST PIN	TP-138 IPS-1820-01-PT	TP201
AT387ZKBAE	CUAH015011G	WIRE	UL 1007 #24 3-150- 3 GRY	W001
AT387ZKBAE	CUAJ015011G	WIRE	UL 1007 #24 3-150-3 WHT	W002
AT387ZKBAE	CUPJ003511G	WIRE W-004	UL 1571 #26 3- 35- 3 WHT	W003
AT387ZKBBE	BCML811025G	C:CERAMIC M/L (1608) TAPE	0.001UF 50V K B	C550
AT387ZKBBE	BCML811035G	C:CERAMIC M/L (1608) TAPE	0.01UF 50V K B	C551
AT387ZKBBE	BCML811035G	C:CERAMIC M/L (1608) TAPE	0.01UF 50V K B	C552
AT387ZKBBE	BCML811035G	C:CERAMIC M/L (1608) TAPE	0.01UF 50V K B	C553
AT387ZKBBE	BCML811035G	C:CERAMIC M/L (1608) TAPE	0.01UF 50V K B	C554
AT387ZKBBE	BCML811035G	C:CERAMIC M/L (1608) TAPE	0.01UF 50V K B	C555
AT387ZKBBE	BCML811035G	C:CERAMIC M/L (1608) TAPE	0.01UF 50V K B	C556
AT387ZKBBE	BDAG1240001	DIODE:LED	LTL1CHKSKNN	D550
AT387ZKBBE	BDAG1240001	DIODE:LED	LTL1CHKSKNN	D551
AT387ZKBBE	BDAG1423004	DIODE:ZENER	HZK6C	D552
AT387ZKBBE	BDLG0659001	LCD	DL-659 912-442A-4611	DP551
AT387ZKBBE	BJKG1547001	JACK	JK-1547	J550
AT387ZKBBE	BLZG0207601	INDUCTOR:MOLDED CHIP	LZ-207 MMZ1608Y601BT 600	L550
AT387ZKBBE	BLZG0207601	INDUCTOR:MOLDED CHIP	LZ-207 MMZ1608Y601BT 600	L551
AT387ZKBBE	BLZG0207601	INDUCTOR:MOLDED CHIP	LZ-207 MMZ1608Y601BT 600	L553
AT387ZKBBE	BLZG0207601	INDUCTOR:MOLDED CHIP	LZ-207 MMZ1608Y601BT 600	L552
AT387ZKBBE	BPAG0471AA2	PCB:FRONT	PA-471AA 2/4	B550
AT387ZKBBE	BRFC161014G	R:CARBON FIXED CHIP(1608)	100 1/16W J TAPE	R555
AT387ZKBBE	BRFC161024G	R:CARBON FIXED CHIP(1608)	1K 1/16W J TAPE	R551
AT387ZKBBE	BRFC161024G	R:CARBON FIXED CHIP(1608)	1K 1/16W J TAPE	R554
AT387ZKBBE	BRFC161024G	R:CARBON FIXED CHIP(1608)	1K 1/16W J TAPE	R552

AT387ZKBBE	BRFC161024G	R:CARBON FIXED CHIP(1608)	1K 1/16W J TAPE	R553
AT387ZKBBE	BRFC162714G	R:CARBON FIXED CHIP(1608)	270 1/16W J TAPE	R550
AT387ZKBBE	BSWG0877001	SWITCH:TACT	SW-877 TC-1105	S550
AT387ZKBBE	BSWG0877001	SWITCH:TACT	SW-877 TC-1105	S552
AT387ZKBBE	BSWG0877001	SWITCH:TACT	SW-877 TC-1105	S551
AT387ZKBBE	BSWG0922001	SWITCH:SLIDE	SW-922 SS-22F07-G	S553
AT387ZKBBE	BWFG3870709	FLAT CABLE	WF-387 3-70-3 7P	FC550
AT387ZKBBE	BWFG3870709	FLAT CABLE	WF-387 3-70-3 7P	FC553
AT387ZKBBE	BWFG3870709	FLAT CABLE	WF-387 3-70-3 7P	FC551
AT387ZKBBE	BWFG3870709	FLAT CABLE	WF-387 3-70-3 7P	FC552
AT387ZKBCE	BPAG0471AA3	PCB:VOL	PA-471AA 3/4	B600
AT387ZKBCE	BRVG1051001	R:VARIABLE	RV-1051 R09711NS-FR18.7A10-A503	VR600
AT387ZKBCE	BWFG3850509	FLAT CABLE	WF-385 3-50-3 5P	FC600
AT387ZKBDE	BPAG0471AA4	PCB:SQ	PA-471AA 4/4	B650
AT387ZKBDE	BRVG1052001	R:VARIABLE	RV-1052 R09711NO-FR18.7A10-B502	VR650
AT387ZKBDE	BWFG3820509	FLAT CABLE	WF-382 3-50-3 2P	FC650
AT387ZKBEE	BDXG2076001	IC CHIP:DX-2076(001)	MB89985L-G-228-CHIP	IC300
AT387ZKBEE	BMXG2076101	COB MODULE	MX-2076(101)	MO300
AT387ZKBEE	BPXG0002CDZ	PCB:COB PCB 64PIN	PX-0002CD	B300
AT387ZKBYE	BDBL2078105	TRANSISTOR	DB-791 2SC2078E	Q502
AT387ZKBYE	BJKG1639003	JACK:ANT W/O ACC	JK-1639 M-RM-L 102	J501
AT387ZKBYE	BSPG0618001	SPEAKER	SP-618 YD45B-RB38F8-R4	SP501
AT387ZKBYE	BWZY1105001	CORD:DC CORD	WZ-1105 1500 W/P	WA501
AT387ZKBYE	BYYG1659001	INSULATION SHEET	YY-1659 WCP23-16-9.4-2.0	Y501
AT387ZKXYE	BMKG0656001	MICROPHONE	MK-656 IP743-H010605	MC951