

Commander

PR-23

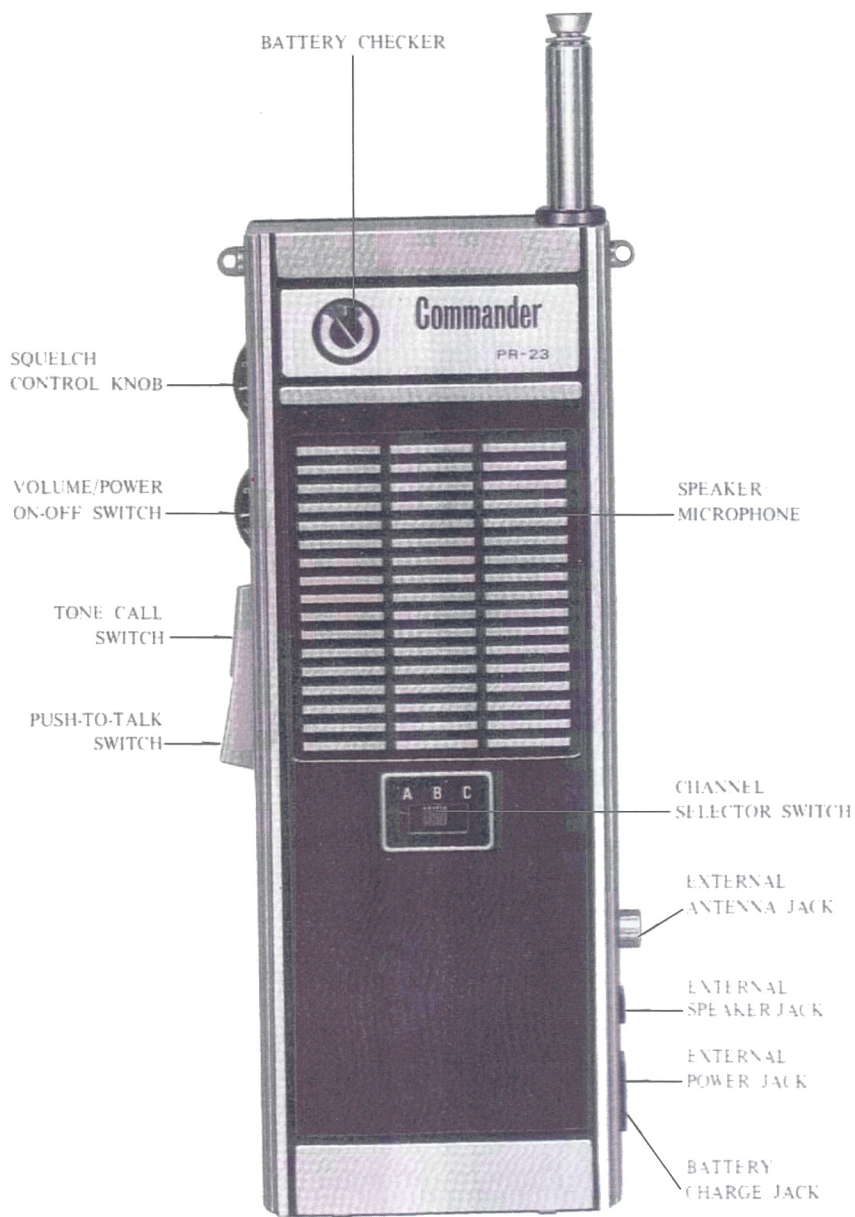

OWNER'S GUIDE



SPECIFICATIONS, PR-23

Transistors	13
Channel Number	3, on 27MHz Citizens Band
Transmitter Frequency	
Tolerance	$\pm 0.005\%$
RF Input Power	2 Watt
Tone Call Frequency	2000Hz
Receiver Type	Superheterodyne
Receiver Sensitivity	0.7 μ V at 10dB S/N
Selectivity	45dB at ± 10 KHz
IF Frequency	455KHz
Audio Output	1 W to External Speaker Jack
Power Supply	8 UM-3 (penlite battery)
Current Drain	Transmitter : 220-380mA Receiver : 25-180mA
Accessory	Sholder strap Battery UM-3, 8 pcs Instruction Manual

INTRODUCTION

Your attractive PR-23 is a compact hand-held transceiver, designed for portable two-way radio communication in 27MHz Citizens band. Housed in a rugged die-cast case, the PR-23 comprises a fully miniaturized transmitter and receiver, both crystal controlled for precise, dependable operation. This unit employs a sensitive superheterodyne receiver circuit with one stage of RF and two stages of IF and three stages of transmitter which uses rugged silicon transistors.

Other receiver features include: an efficient squelch circuit which silences the receiver when no signals are being received. Push-pull audio for high output and undistorted sound and AGC (Automatic Gain Control) to prevent overloading on strong signals and to maintain uniform sound output. For increased selectivity, a 455KHz Ceramic filter is employed.

This unit has a built-in calling device, which allows you to receive and transmit a call signal. The function of the calling device can be tested by pressing both Push-to-Talk switch and tone call switch simultaneously. This transceiver has also a battery checker for your convenience.

BATTERY INSTALLATION

1. Using a coin or screw driver, turn the large screw at lower corner of the rear cover in counter-clockwise direction and open the battery compartment cover. Pry off the snap connector attached to the plastic battery compartment. Insert the eight 1.5 volts penlite cells into the compartment. Note that in all cases the negative end (case) of the battery makes contact with a spring. When inserting a battery, always insert the negative end into the compartment first and then the positive end.
2. When all batteries have been inserted into the unit, attach the snap connector to the compartment.
3. Replace the rear cover.

IMPORTANT: Do not leave batteries in the unit when the transceiver is not used for long period of time. This will prevent battery leakage and possible damage to the unit.

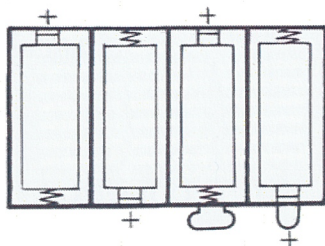

Positioning of Cells:

Install eight penlite (UM-3 type)
batteries as shown in the illustration.

FIGURE 1. BATTERY INSTALLATION

OPERATION INSTRUCTIONS

WARNING: Please do not attempt to transmit with this unit prior to receipt of your license if it is required, unless your authority provides for its use.

1. Extend the telescoping antenna to its full length.
2. Rotate the volume control downward to turn the unit on.
Place the squelch control in open (zero) position initially, and then increase volume until background noise is heard.
3. This transceiver is equipped with a combined speaker/microphone which is located behind the grill. To transmit, hold the unit so that the grill is 3 to 4 inches away from your lips and fully depress the Push-to-Talk switch. (Do not depress both Tone Call and Push-to-Talk switch simultaneously this should be done for tone call operation only).
Speak clearly at the normal voice level. When you complete your message, release the button.

NOTE: When one unit is transmitting, it is not possible for this unit to hear any messages directed to it. Do not, therefore, attempt to talk until the other station is finished transmitting.

4. The squelch circuit in the receiver section of the unit is used to eliminate annoying background noise when no signals are present. To adjust the Squelch control properly during reception, turn the volume control until background noise is heard. (No signals should be present). Slowly rotate the squelch control downward until the background noise almost disappears. At this point, the receiver will be relatively quiet, but a incoming signal will overcome the squelch action and will be heard. Do not advance the control knob too far. or some of the weaker signals will not be heard. If you wish to receive extremely weak signals or disable the squelch circuit, turn the knob fully upward direction.
5. When using the earphone for private listening, simply plug it into the speaker jack on the lower side of the unit.
This will automatically cut off sound from the built-in speaker.
Small build-in meter on front top case serves as a battery checker.
The meter pointer falling on a left red area with no signal received indicates that the battery condition is no good. Replace all the batteries at the same time with new ones. (The pointer falling on green area shows the battery condition is good)

OPERATING FREQUENCIES

The transceiver may be operated on any three channels in the 27MHz Citizens Band. Both receiver and transmitter are crystal-controlled, and are normally equipped with crystals for operation on one channel.

Additional matched pairs of crystals may ordered for operation on other channels.

CHANGING OR ADDING NEW CHANNELS

To change (or add) the channel on which your transceiver operates, it is only necessary to change (or add) the new transmitting and receiving crystals in the unit. This is a relatively simple procedure which requires no returning or other adjustments.

1. Remove two large screws on the rear cover, using a coin or screw driver.
2. Figure 2 shows the location of the transmit and receive crystals.
Replace or insert the new matched crystals to the proper sockets. Each crystal will be marked with the channel, transmit or receive (T or R), frequency. Make sure the transmitter (T) and receiver (R) crystals are installed in their correct sockets. If crystals are reversed, the unit will transmit on one frequency and receive on another, both of which will be outside the Citizens Band, resulting in illegal operation.
3. Replace the rear cover and tighten the screws firmly.
The unit is now ready for operation.

EXTERNAL ANTENNA JACK

An external antenna jack which accept standard RCA type phono plug is provided on right side-cabinet for your convenience. When using this jack with an external antenna connected, collapse the built-in telescoping antenna.

EXTERNAL DC POWER JACK

An external DC power jack is also provided at lower side-cabinet. When a power plug of external power adaptor is connected to this jack, the internal (battery) power circuit is automatically cut off and no power will be drawn from the internal batteries, thus saving the service life of internal batteries.

BATTERY CHARGE JACK

This jack will be used for charging batteries when rechargeable batteries such as nickel cadmium batteries, etc. are installed. (Do not try to charge conventional non-rechargeable batteries.)

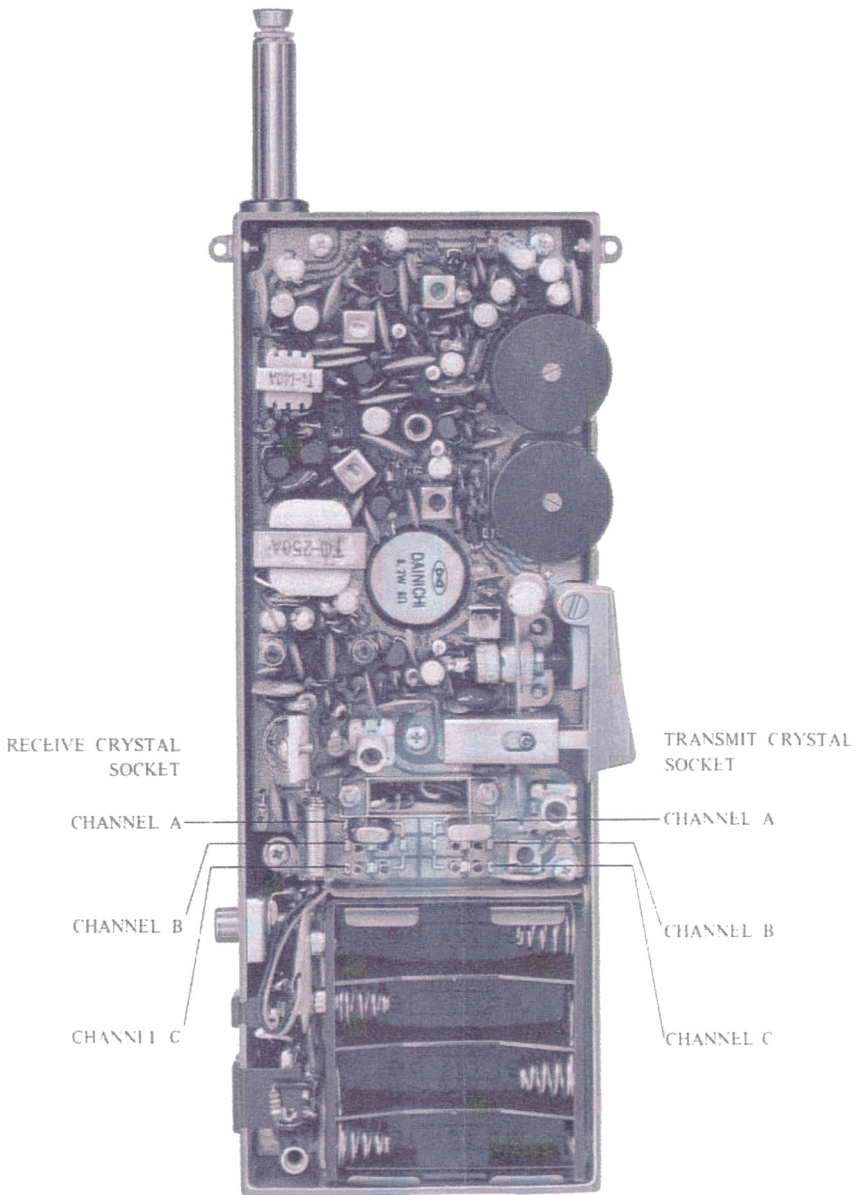
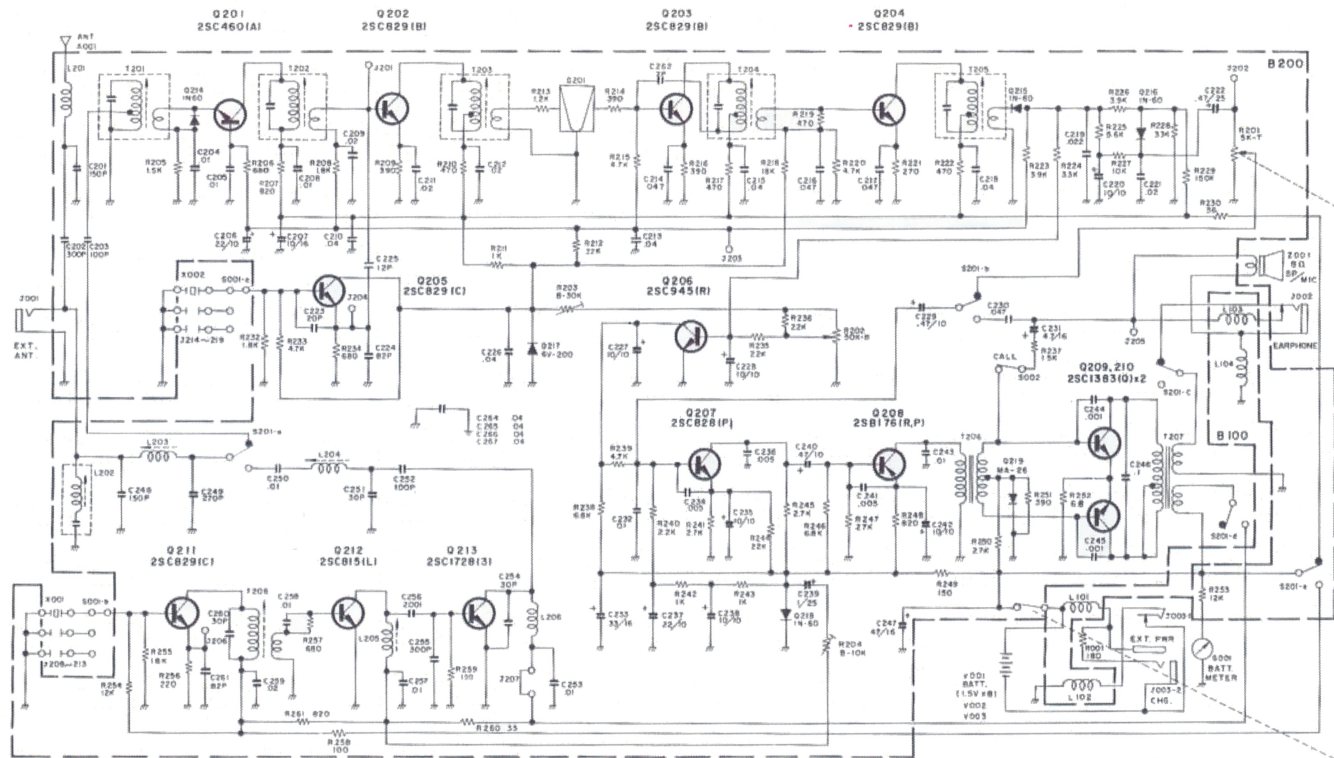

FIGURE 2. RECEIVE AND TRANSMIT CRYSTAL SOCKETS



Schematic Diagram

Lafa RADIO AB

ARLÖV, SWEDEN TEL 040-436020