

REFLECTOR ASSEMBLY - Color Coded YELLOW

Element (part 15) is pre-assembled. Insert element sections (part 17) to desired setting, according to Frequency Chart, and secure with screws (part 8). Place trap assemblies (part 18) into element sections (part 17) and secure with screws (part 8).

DIRECTOR ASSEMBLY - Color Coded GREEN

Element (part 21) is pre-assembled. Insert trap assemblies (part 22) into element sections (part 21), according to Frequency Chart, and secure with screws (part 8).

RADIATOR ASSEMBLY TO BOOM:

Loosely install two U-bolts (part 12) to element support (part 1) with lock washers, nuts, and ground strap (parts 13, 14, and 5). Push boom (part 20) through U-bolts (part 12) until the Red color code mark on boom is centered under support (part 1). Install clamping block (part 10) between element support (part 1) and boom (part 20) and secure U-bolts.

REFLECTOR AND DIRECTOR ASSEMBLY TO BOOM:

Note that radius of grooves on clamping block (part 11) conforms with radius of boom (part 20) and elements (parts 15 and 21). Place element clamping block (part 11) between U-bolt (part 12) and elements (parts 15 and 21). Place U-bolt (part 12) over boom (part 20) and center on top of corresponding color code on boom. Secure with washers and nuts (parts 13 and 14).

BOOM TO MAST PLATE:

The Black mark on boom is to indicate the center of the mast plate (part 19). Secure mast plate to boom by means of U-bolts, clamping blocks, washers and nuts (parts 12, 10, 13, and 14). Use the same method as on the radiator. The remaining U-bolts and hardware are to be used to clamp your 1½" (outside diameter) mast section to the mast plate. For 2" OD masts Mosley Electronics manufactures Model AK-60 Mast Adapter Kit. This kit includes an aluminum angle, hardware and complete instructions.

A package of Mosley Weather Guard has been included with this antenna. After antenna has been assembled, spray or brush weather guard over entire unit and let dry before mounting on mast. Be sure weather guard does not prevent good electrical contact between boom and mast.

FREQUENCY CHART				
ELEMENT	COLOR	BAND	CODE 1*	11**
RADIATOR	RED	10 Meters	28.5	29.00
REFLECTOR	YELLOW	15 Meters	21.150	21.350
DIRECTOR	GREEN	20 Meters	14.150	14.250
<i>*Best for CW</i>			<i>**Best for Phone</i>	

NOTE: To order replacement parts from instruction sheet, refer to Form No. and Part No.

M · E · I

MOSLEY ELECTRONICS, INCORPORATED
4610 North Lindbergh Boulevard
Bridgeton, Missouri 63042

ASSEMBLY INSTRUCTIONS

FOR

MOSLEY THREE ELEMENT

TRAP MASTER ANTENNA

MODEL TA-33 JR.

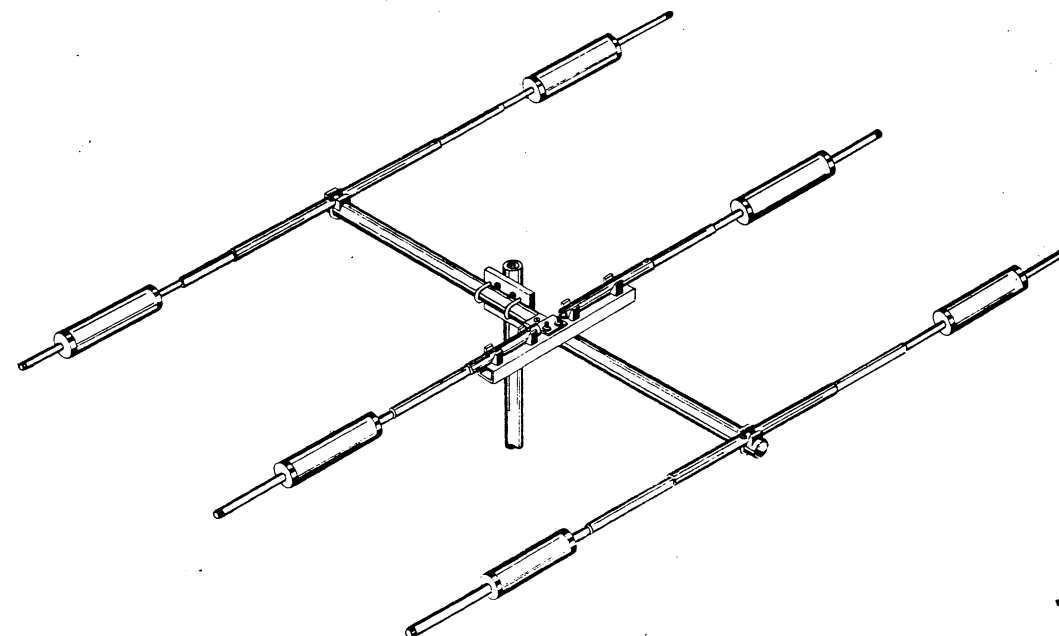

The high performance of your MOSLEY Antenna can only be achieved if the antenna is assembled in accordance with the instructions supplied. Substitution of materials or modification of design will materially lessen this performance.

PARTS LIST

Part	Quantity	Description
✓1	1	Element Support
✓2	4	Insulators
✓3	8	10-32 x 1¼" Screws
✓4	12	No. 10 Internal Lock washers
✓5	1	Ground Strap
✓6	2	Radiator Assembly (color coded RED)
✓7	2	Trap Assemblies (color coded RED)
✓8	8	Sheet Metal Screws, No. 6 x 3/8"
✓9	2	Solder Lugs, No. 6
✓10	5	Element Clamping Blocks, No. 44
✓11	2	Element Clamping Blocks, No. 41
✓12	8	U-Bolts
✓13	16	¼" Internal Lock washers
✓14	16	¼-20 Nuts
✓15	1	Reflector Assembly (color coded YELLOW)
✓16	2	1¼" Metal Caps
✓17	2	5/8" OD Element (color coded YELLOW)
✓18	2	Trap Assemblies (color coded YELLOW)
✓19	1	Mast Plate
✓20	1	Boom
✓21	1	Director Assembly (color coded GREEN)
✓22	2	Trap Assemblies (color coded GREEN)
✓23	2	5/8" Metal Caps
✓24	4	10-32 x 1½" Screws

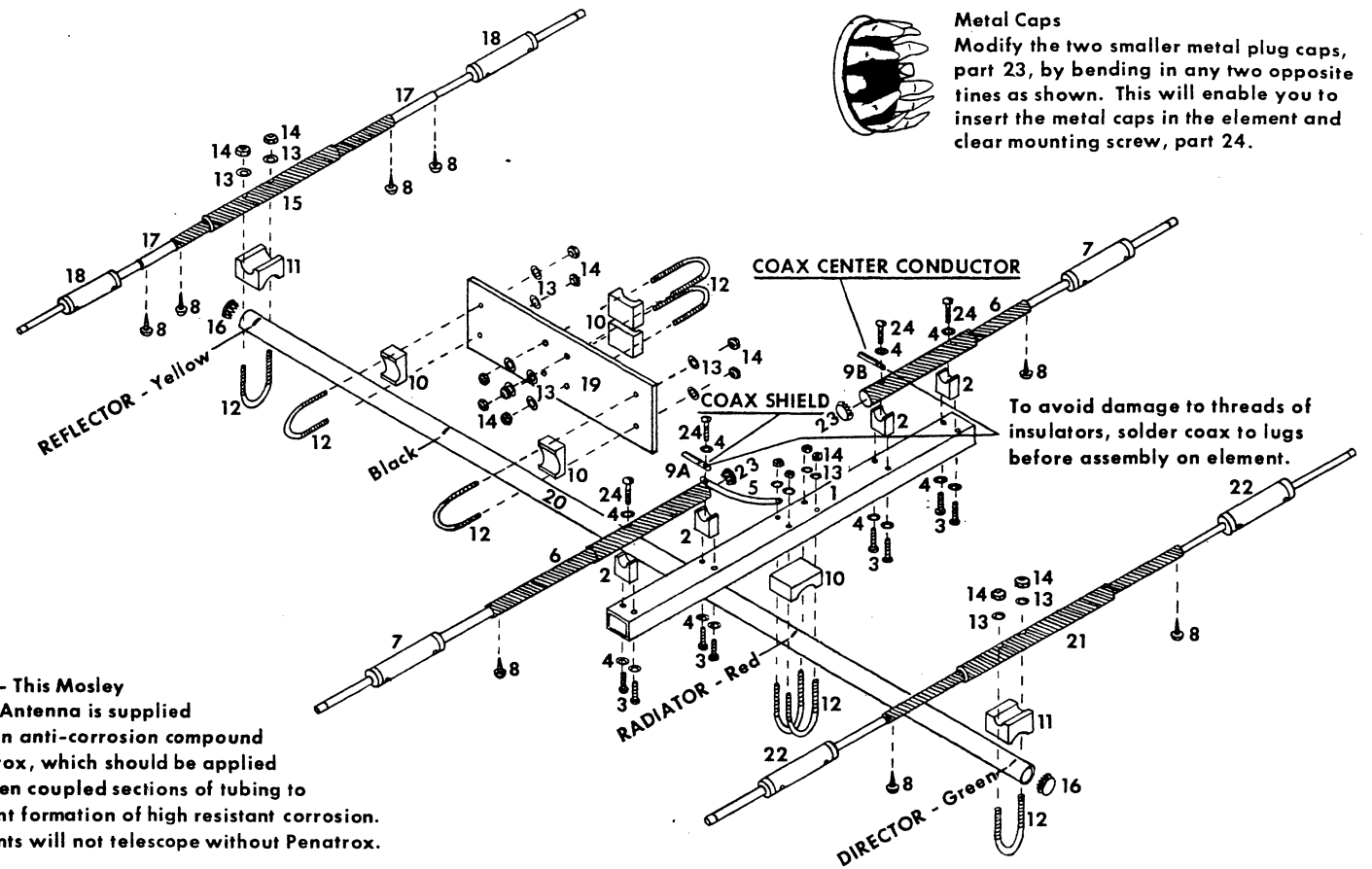

ASSEMBLY

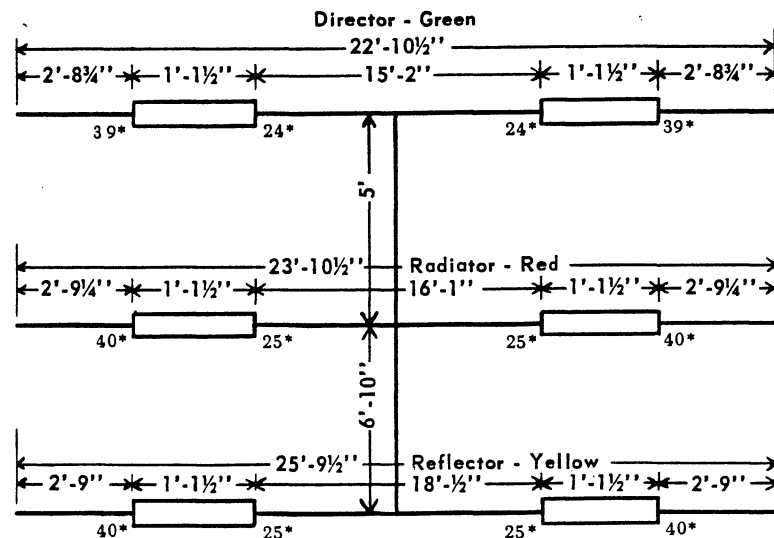

Settings are for Code 11, add 10½" to center dimension for Code 1.

* Indicates number of coil turns.

CAUTION: Coil assemblies are color coded on one end only; this color should ALWAYS be nearest the boom. Reversal of traps will cause high SWR and other malfunction of beam. The ½" element on the trap assembly of the radiator (color coded red) is drilled so that it may be adjusted. The coding on the adjusting holes may be determined from the frequency chart. Adjusting holes do not appear on the reflector (color coded yellow) trap assembly, but on element section (part 17).

All trap assemblies are provided with "breather holes" and should face DOWN.

Each trap assembly has a ½" plastic cap on one end, indicating that it is the outside end of the element and a moisture seal. **DO NOT REMOVE!**

Read Directions Carefully!

Begin assembly by grouping all element and coil sections according

to color code. For proper matching, use 52 ohm coax. RG-8/U is recommended. Use ½ wavelength or more of coax.

RADIATOR ASSEMBLY - Color Coded Red

Loosely install insulators (part 2) to element support (part 1) with screws and lock washers (parts 3 and 4). Place element assembly (part 6) into "V" of insulators (part 2) so that screw hole on Red color end of element (part 6) is facing down. Place screws (part 24) through washers (part 4) and secure to outermost insulators (part 2). Connect coax cable to solder lugs (part 9). Place screws (part 24) through washer, solder lug, ground strap, and element, (parts 4, 9A, 5 and 6) and secure to insulator (part 2). Insert screw (part 24) through washer, solder lug, and element, (parts 4, 9B, and 6) and secure to insulator (part 2). Secure all insulators. Insert Red color coded end of trap assemblies (part 7) into element sections (part 6) and secure with screws (part 8).