



**IOJXX** di Donzello Rosanna

Via della Fattoria di Torrenova 3 - 00133 Roma - Italy















& Fax +39 (0) 6 - 27858223 +39 3282899664

VAT number: IT09527381009

[www.iojxx.com](http://www.iojxx.com) - [info@iojxx.com](mailto:info@iojxx.com)

 Skype: [i0jxx.com](https://www.skype.com/add?contact=i0jxx.com)

## 16JXX2 Yagi

Item		Q.ty	Item		Q.ty
Stainless steel nut M5		7	Stainless steel bolt M4x35		1
Stainless steel nut M6		10	Stainless steel bolt M5x40		2
Nylon nut M8		15	Stainless steel bolt M5x45		2
Clamp Bazooka		1	U_Bolt 50		3
Lock washer 4 mm Ø		1	U_Bolt 40		2
Lock washer 5 mm Ø		7	Ergal Plate <b>PIA40JXX</b>		1
Lock washer 6 mm Ø		10	Horizontal element <b>1 ÷ 16</b>		15
Flat washer 6 mm Ø		10	Stainless steel Turnbuckle		2
Section boom <b>A</b> 25 mm Ø	135 cm.	1	Stainless steel Eyescrew M5		2
Section boom <b>A - B</b> 30 mm Ø	140 cm.	1	Dipole with Bazooka		1
Section boom <b>B - C</b> 35 mm Ø	140 cm.	1	Dacron rope front	410 cm.	1
Section boom <b>C - D</b> 40 mm Ø	142 cm.	1	Dacron rope back	300 cm.	1
Section boom <b>D - E</b> 35 mm Ø	140 cm.	1	Inbuss key 3 mm.		1
Section boom <b>E - F</b> 30 mm Ø	140 cm.	1			
Section boom <b>F</b> 25 mm Ø	140 cm.	1			

Total Field

EZNEC+

Total Field

EZNEC+

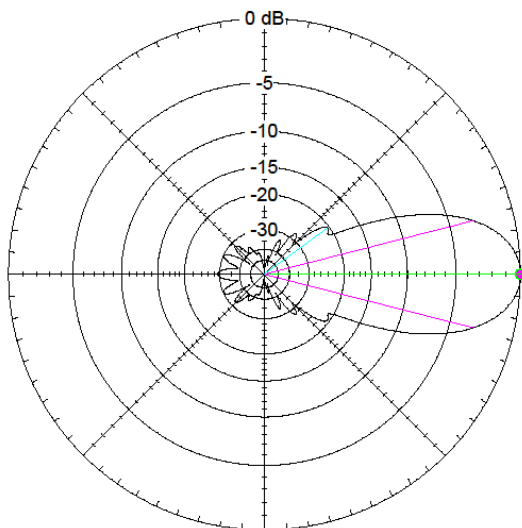

Dipole in free space

144,4 MHz

Azimuth Plot  
Elevation Angle 0,0 deg.  
Outer Ring 16,51 dBi

Cursor Az 0,0 deg.  
Gain 16,51 dBi  
0,0 dBmax  
0,0 dBmax3D

3D Max Gain 16,51 dBi  
Slice Max Gain 16,51 dBi @ Az Angle = 0,0 deg.  
Front/Back 29,22 dB  
Beamwidth 28,8 deg.; -3dB @ 345,6, 14,4 deg.  
Sidelobe Gain -3,87 dBi @ Az Angle = 36,0 deg.  
Front/Sidelobe 20,38 dB

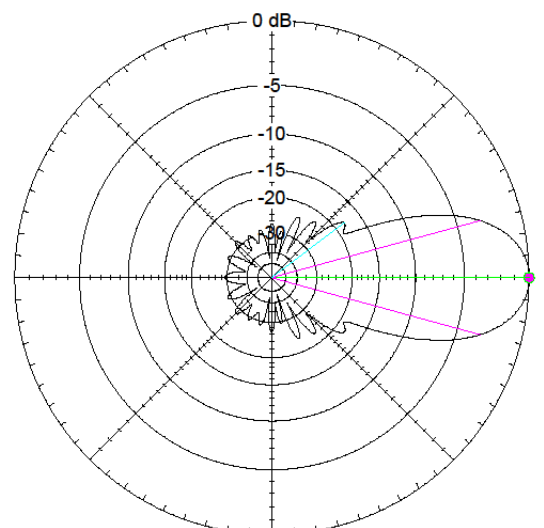

Dipole in free space

144,4 MHz

Elevation Plot  
Azimuth Angle 0,0 deg.  
Outer Ring 16,51 dBi

Cursor Elev 0,0 deg.  
Gain 16,51 dBi  
0,0 dBmax  
0,0 dBmax3D



3D Max Gain 16,51 dBi  
Slice Max Gain 16,51 dBi @ Elev Angle = 0,0 deg.  
Front/Back 29,22 dB  
Beamwidth 30,6 deg.; -3dB @ 344,7, 15,3 deg.  
Sidelobe Gain -1,38 dBi @ Elev Angle = 37,0 deg.  
Front/Sidelobe 17,89 dB

**IOJXX** may vary them without any warning

Made in Italy  
[www.iojxx.com](http://www.iojxx.com)





 Combine the boom respecting the letters placed at the ends of each section. Insert the Eyescrew M5 mm washer and nut into the junction points **A - A** and **F - F** then insert the screws M5x40 mm washer and nut, junction points **B - B** and **E - E**, insert the screws M5x45 mm washer and nut, junction points **C - C** and **D - D**

  Combinez le boom sur les lettres placées aux extrémités de chaque section. Insérez les vis M5 rondelle et un écrou dans les points de jonction **A - A** et **F - F** puis, insérez les vis M5x40 mm rondelle et un écrou, les points de jonction **B - B** et **E - E**, insérez les vis M5x45 mm rondelle et un écrou, les points de jonction **C - C** et **D - D**

 Kombinieren Sie den Boom und achten Sie dabei auf die Buchstaben am Ende jeder Sektion. Fügen Sie die Schrauben M5 Unterlegscheibe und Mutter in die Verbindungsstellen **A - A** und **F - F**, und die Schrauben M5x40 mm Unterlegscheibe und Mutter in den Knotenpunkte **B - B** und **E - E**, und die Schrauben M5x45 mm Unterlegscheibe und Mutter in den Knotenpunkte **C - C** und **D - D**

 Unire il boom rispettando le lettere poste alle estremità di ogni sezione. Inserire le viti ad occhio da M5 mm rondella e dado, nei punti **A - A** e **F - F**, le viti M5x40 mm rondella e dado per **B - B** e **E - E**, le viti M5x45 mm rondella e dado per **C - C** e **D - D**

 Attach the mounting plate between boom and mast **PIA40JXX** between elements **7 - 8**

 Fixez la plaque de montage entre la flèche et le mât **PIA40JXX** entre les éléments **7 - 8**

 Montieren Sie die Montageplatte zwischen Ausleger und Mast **PIA40JXX** zwischen den Elementen **7 - 8**

 Montare la piastra di fissaggio tra boom e mast **PIA40JXX** tra gli elementi **7 - 8**

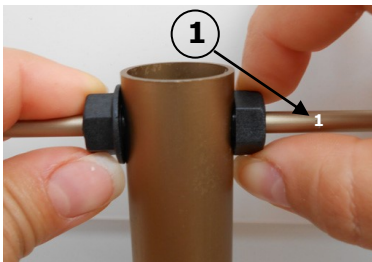



 Insert elements as shown in the figure, hand tighten the nut M8 Nylon (**do not use keys as the material used has a self - locking function**)

 Fügen Sie die Elemente hinein wie in der Abbildung dargestellt, schrauben Sie die Mutter M8 Nylon mit den Händen zusammen (**benutzen Sie keine Schlüssel, da das verwendete Material eine Selbstverriegelung hat**)

 Insertion d'éléments comme indiqué sur la figure, serrez à la main l'écrou M8 nylon (**ne pas utiliser les touches que le matériau utilisé a une auto - verrouillage**)

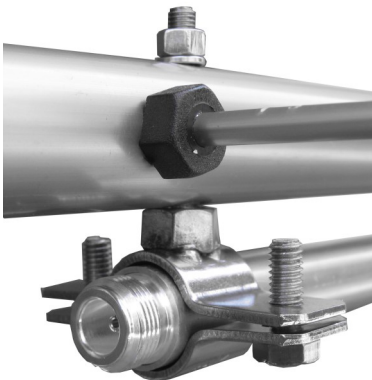
 Inserire gli elementi come riportato in figura, stringere a mano il dado in Nylon da M8 (**non utilizzare chiavi in quanto il materiale impiegato ha effetto auto - bloccante**)



 Match the dipole with M4x35 mm and washer as shown in photo

 Verbinden Sie die Dipole mit der M4x35 mm Schraube und der Unterlegscheibe wie das Foto zeigt

 Installez les dipôles avec M4x35 mm et la rondelle comme sur la photo

 Montare il dipolo con vite M4x35 mm e rondella come in foto

## Stacking

In order to obtain the best results in coupling the antennas, we warmly recommend an adequate antenna stacking calculation which would allow the best forward gain together with low side lobes. The stacking distance may be calculated with the following formula from Güenter Hoch DL6WU

On the basis of further studies conducted by Lionel VE7BQH over the antenna stacking argument, a reduction of 5÷10% may be introduced on stacking distances without noticing significant overall worsening of the characteristics. Do respect the driven element supplying symmetry to allow anti-phase coupling

$$\text{Plane E} = 28.8^\circ = \frac{2079}{2 * \sin(28.8 / 2)} = \frac{2079}{0.4974} \cong 4.18 \text{ m (with VE7BQH from 3.97 m to 3.76 m)}$$

$$\text{Plane H} = 30.6^\circ = \frac{2079}{2 * \sin(30.6 / 2)} = \frac{2079}{0.5277} \cong 3.94 \text{ m (with VE7BQH from 3.74 m to 3.55 m)}$$

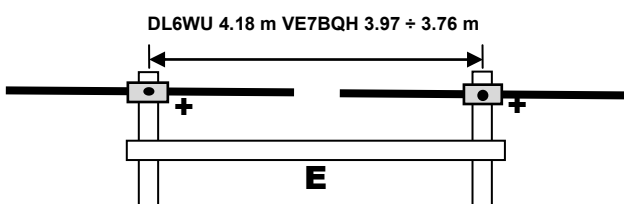

$$d = \frac{L}{2 * \sin(\Phi / 2)}$$

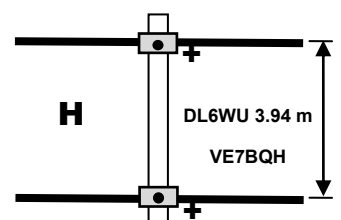

**IØJXX** may vary them without any warning  
**Made in Italy**  
[www.iøjxx.com](http://www.iøjxx.com)

# 16JXX2

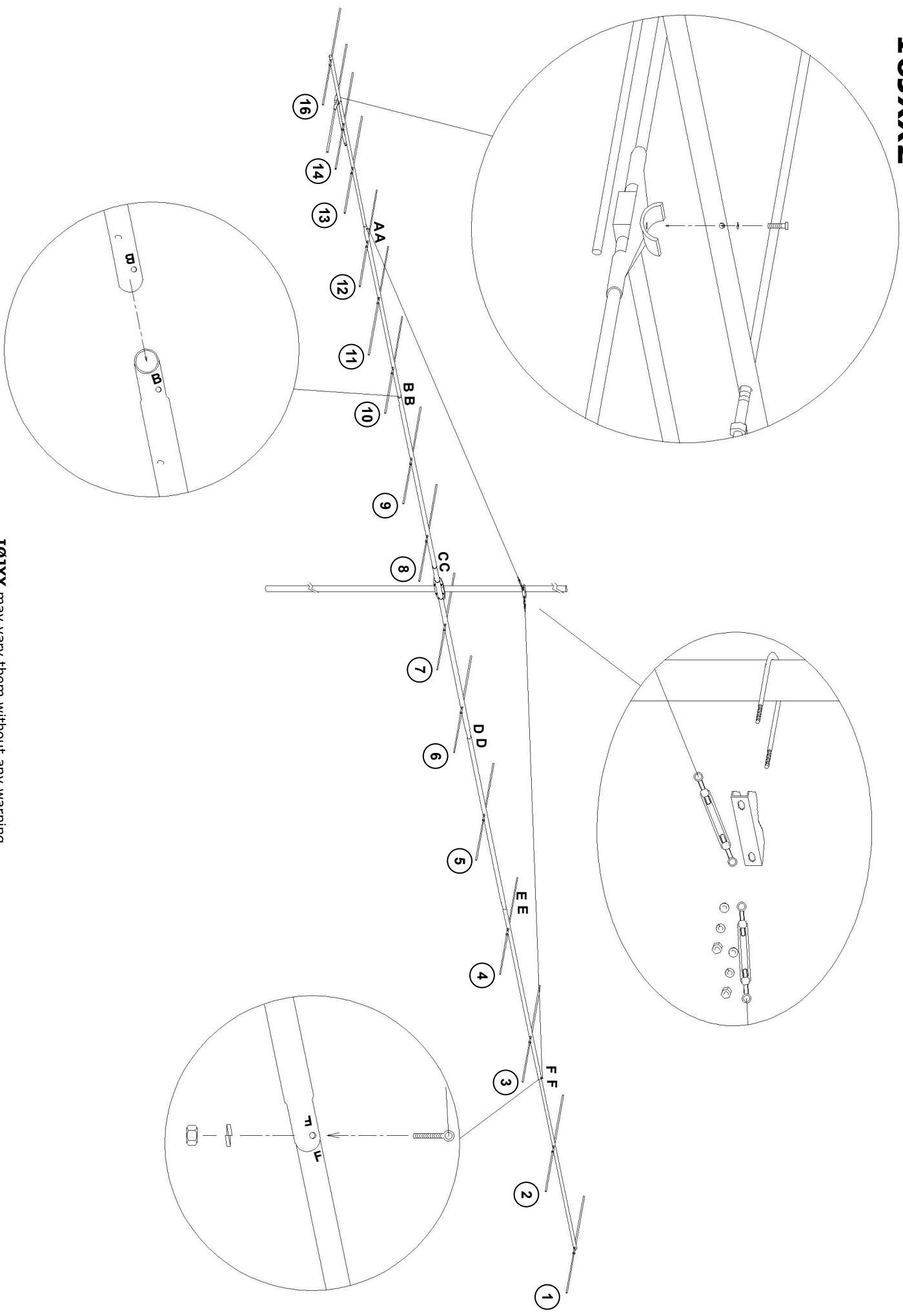

16JXX2 may vary them without any warning

Made in Italy

[www.i0jxx.com](http://www.i0jxx.com)

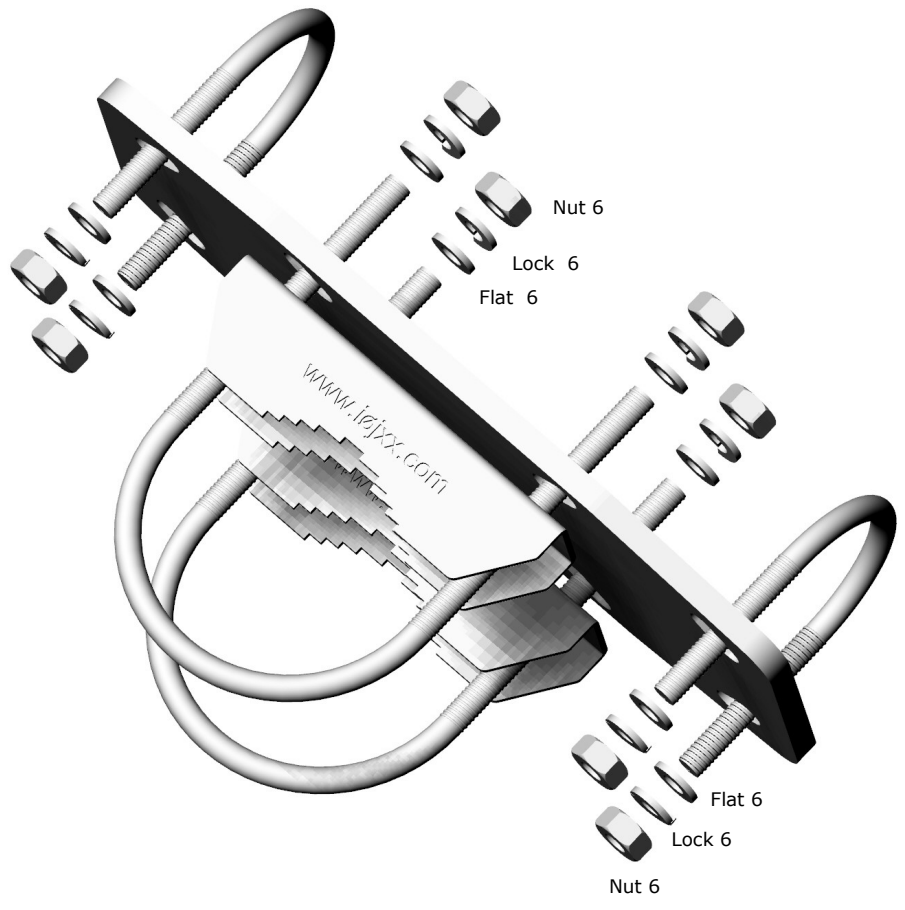
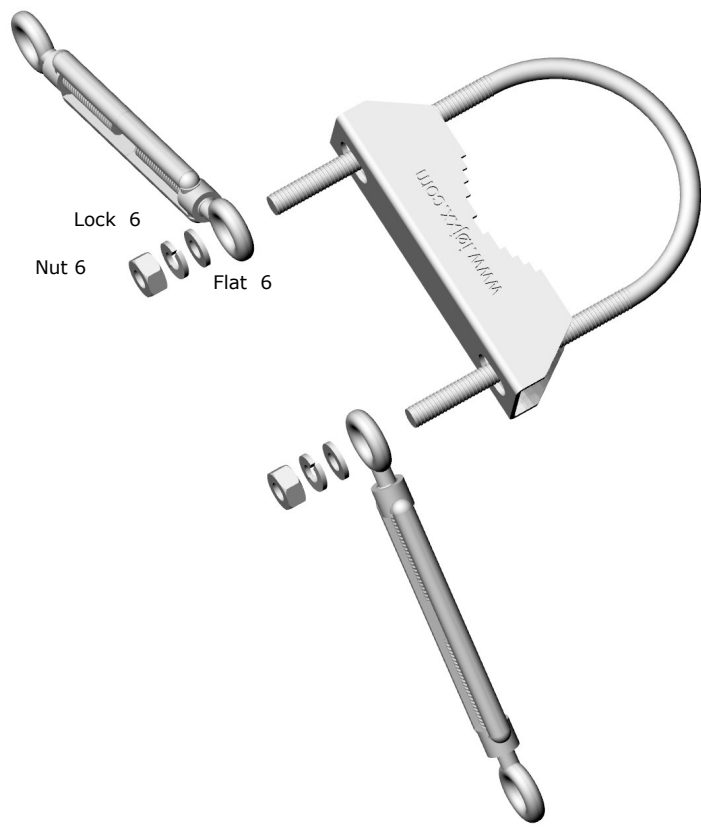

I0JXX may vary them without any warning  
Made in Italy  
[www.i0jxx.com](http://www.i0jxx.com)