

YAESU
The radio

**Network Remote Control System
SCU-LAN10**

Installation Manual

Preparation Procedure

The network remote control system requires a compatible transceiver (FTDX101MP/FTDX101D as of April 2020), a Windows 8.1 or later PC that has a LAN port and audio function, Internet and a LAN network.

System Requirements

- **Supported Transceiver**

- FTDX101MP/FTDX101D (as of April 2020)

- **PC**

- OS : Microsoft® Windows® 8.1/10 (32bit / 64bit)
- LAN Port (100BASE-TX/1000BASE-T)
- Audio interfaces (Speaker or Headphone, and Microphone)

- **Local Area Network**

- **Internet connection** (Download speed: at least 2 Mbps , Upload speed: at least 1.2 M bps are recommended at the PC Side)

- **Ethernet cable**

Commercially available straight Ethernet cable (category 5e or higher)

- **PC Software**

Download the “SCU-LAN10 Remote Software” and “SCU-LAN10 Setting Tool” from our website.

Initial settings for SCU-LAN10 and remote control software are required.

These initial settings are required only once at the first time.

- ① **Check the LAN for installing the transceiver (P.8)**
- ② **Install the software on a computer (P.10)**
- ③ **Preparation for initial setting (P.13)**
- ④ **Setting the SCU-LAN10 (P.18)**
- ⑤ **Restore the network settings of the computer (P.25)**
- ⑥ **Initial setting of FTDX101MP/D (P.28)**
- ⑦ **Open UDP port of router (P.30)**
- ⑧ **Remote connection (P.31)**

Contents

Preparation Procedure	2
Introduction	4
Important	4
Important Notes	4
Precautions for use	4
Trademarks	4
System Requirements (Operating Environment)	5
Other notes and restrictions	6
Packing List	6
SCU-LAN10	7
Front panel.....	7
Rear panel.....	7
① Check the LAN for installing the transceiver	8
② Install the software on a computer	10
Install Microsoft .NET Framework 4.X.....	10
Install the Network Remote Control Software.....	11
③ Preparation for initial setting	13
Connect device.....	13
Temporarily change the PC network settings.....	14
④ Setting the SCU-LAN10	18
Other functions of SCU-LAN10 Setting Tool.....	23
⑤ Restore the network settings of the computer	25
⑥ Initial setting of FTDX101MP/D	28
Settings for transmit audio.....	28
CAT Rate setting.....	28
CAT TIME OUT TIMER setting.....	28
CAT RTS setting.....	28
VOX SELECT setting.....	28
TOT (Time Out Timer) setting.....	28
⑦ Open UDP port of router	30
Open the router setting screen.....	30
Set the UDP port to open.....	30
⑧ Remote connection	31
Install the SCU-LAN10 and FTDX101MP/D.....	31
Initial settings for remote control software.....	33
About setting items.....	34
Initial audio level settings.....	35
Windows volume control.....	35
Volume control of SCU-LAN10 Network Remote Control Software.....	39
Start remote control.....	40

Introduction

The SCU-LAN10 and the Network Remote Control Software are products for remotely operating compatible transceivers using the Internet or LAN.

Important

Before downloading this software, please read the “Important Notes” carefully.

Downloading or installing this software will be taken as indicating your agreement with the contents of the “Important Notes”.

Important Notes

- To remotely control a transceiver using the SCU-LAN10, be sure that you comply with your local regulations.
- All responsibility for the use of this software lies with the customer. Yaesu cannot be held responsible in any way for any damages or losses which may be incurred by the customer as a result of using this software.
- Copyrights and all other intellectual property rights for the software, as well as the software manual, are the property of YAESU MUSEN CO., LTD.
- The revision, modification, reverse engineering, and decompiling of this software is prohibited. Redistribution, transfer, and resale of downloaded files are also prohibited.
- Downloaded files may only be used for personal use.

Precautions for use

- Settings for remote operation require knowledge of PCs and networks as well as transceiver settings. We do not provide support for the PC settings or network settings.
- For the operation of a PC and peripheral devices, follow the instructions provided in the manuals that come with the PC and peripheral devices.
- To use SCU-LAN10, you need to open the port of the router and change the settings of the firewall and security software. Customers are responsible for network security when using this product.
- In communication using a network, changes in audio, operation delay, and changes in voice quality occur, this cannot be improved in principle.
- Depending on the environment or status of a network, PC, OS, security software, etc., the procedures described in this manual may not work as expected.
- As a result of using SCU-LAN10 and software, we will not be liable for incidental damages such as damages caused by missed communication and call opportunities due to customer's incorrect settings, or malfunctions. Use of this software is at your own risk. Yaesu shall not be liable for any damages caused to you by using this software.

Trademarks

Microsoft®, Windows®, Windows® 8.1, Windows® 10 are registered trademarks in the United States and other countries.

System Requirements (Operating Environment)

● Supported Transceivers

FTDX101MP, FTDX101D (As of April 2020)

● The latest Transceiver Firmware



Update to the latest software and firmware on the YAESU website (<https://www.yaesu.com>).

- **FTDX101MP/D** MAIN: V01-14 or later
 DISPLAY: V01-06 or later
 IF DSP: V01-05 or later
 SDR: V02-03 or later

● PC

• OS

Microsoft® Windows® 10(32 bit/64 bit)

Microsoft® Windows® 8.1(32 bit/64 bit)

※ S mode is not supported, application runs in 32bit mode

• CPU

Intel® i5-3470, i7-3770 or higher, or equivalent or higher performance
(CPU clock 3.2GHz, quad core or above)

• RAM (System memory)

4GB or more

• HDD (Hard Disk)

10GB or more free space recommended

• LAN port 100BASE-TX/1000BASE-T

• Audio interfaces

• Speaker or Headphone

• Microphone

• Microsoft .NET Framework 4 or higher is installed (enabled)



When using a USB Audio type microphone or speaker, the performance of the PC including the OS will be affected. Therefore, the sound may be interrupted, or the remote control may be delayed.

● LAN

● Internet connection (Download speed: at least 2 Mbps, Upload speed: at least 1.2 M bps are recommended at the PC Side)

Communication is possible with the following 4 ports among UDP (user datagram protocol) ports.

50000 - 50003 (Factory setting)

※ Address conversion function (NAPT, IP masquerade) is required when using a router.



- If your router or computer has a firewall function, you need to allow communication to the above ports.
 - If the Internet line is also used for other purposes, audio may be interrupted, or remote control may become unstable.
-

● Fixed global IP address or fixed domain name (for remote control using Internet line)

When using the Internet, a fixed global IP address or fixed domain name is required for the network where the remote controlled radio is installed.

● Ethernet cable

Commercially available straight ethernet cable (category 5e or higher)

Other notes and restrictions

In principle, when performing remote operation via a network, delays and data loss are inevitable, and smooth operation may not be possible as in direct transceiver operation. Specifically, the following phenomena may occur.

- Sound may be interrupted
- Since the transmit / standby timing may be delayed, it is not suitable for communications that require quick response such as contests and pileups.
- The voice quality of the transmit and receive audio is altered.
- It does not support image communication such as SSTV and digital mode communication such as RTTY (AFSK), JT65, FT8
- CW mode reception is supported, but remote station operation in CW mode is not possible.
- Transceiver power ON / OFF is not available.

Packing List

- **SCU-LAN10 unit**
- **Connection Cable** (13pin DIN plug)
- **USB A-B Cable**
- **Ferrite core** 2 pcs
- **Cable Tie** 2 pcs (For fixing ferrite cores)

SCU-LAN10

Front panel

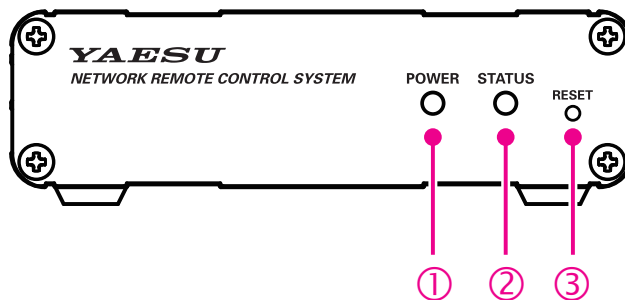

① POWER indicator

Flashes or lights green when the power is on.

② STATUS indicator

In addition to the POWER indicator, various statuses of this unit are displayed.

When main power is supplied to the transceiver, the SCU-LAN10 will start up and enter the standby state. The STATUS indicator (red) starts blinking SCU-LAN10 start up



POWER indicator (green) blinks (after about 12 seconds) SCU-LAN10 standby



POWER indicator (green) lights up Remote control connected

③ RESET switch

When the power is ON, press and hold until the STATUS indicator (red) blinks with a thin object (about 5 seconds), and all the settings of this unit will return to the factory default.

※ Do not push the RESET switch too hard.

Rear panel

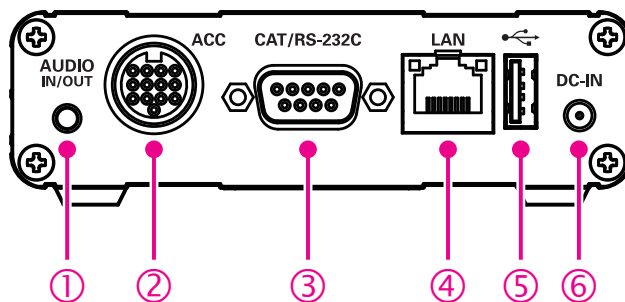

① AUDIO IN/OUT (3.5Φ stereo) jack (Not normally used)*.

This jack is for the output of receive audio and input of (100 mVrms @600Ω).

② ACC connector

Connect to the transceiver with the included connection cable (13pin DIN connector).

③ RS-232C connector*

④ LAN connector

Use a commercially available straight LAN cable (category 5e or higher) to connect to the LAN.

⑤ USB connector

Connect to the transceiver with the included USB cable.

⑥ DC-IN*

External power connector. (DC 10.5 V max 800mA)

* For future expansion. It is not used with the FTDX101D/FTDX101MP.

① Check the LAN for installing the transceiver

As it will be necessary for installation, check the "network environment" of the LAN where the remote control radio is actually installed by following the steps below:



It is not necessary to connect SCU-LAN10 to the network for this confirmation procedure.

Three connection examples are explained below, refer to the explanation that applies to your installation.

(1) For remote control via Internet

When connecting via the Internet, refer to the diagram and check the four designated items.

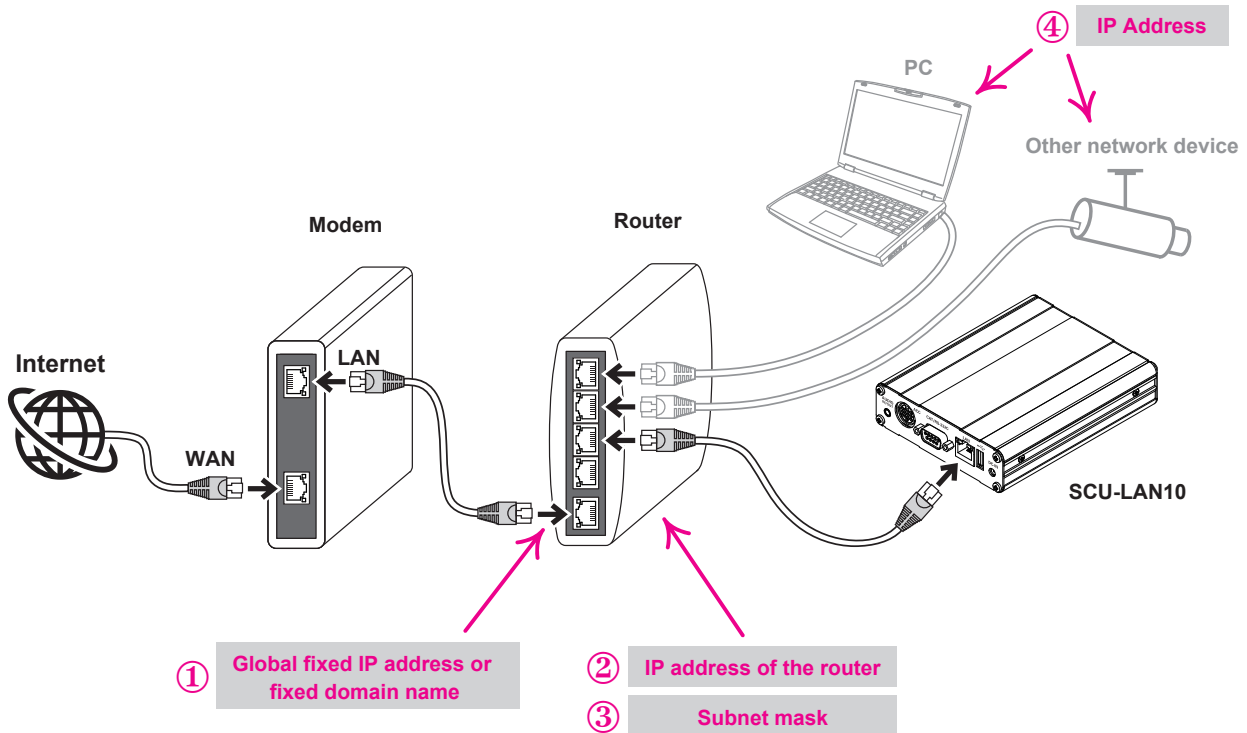

Check the following settings by referring to the instruction manual of your router or other network device. Generally, for setting routers and network devices, use a web browser such as Internet Explorer to access the IP address of the router or network device and display the setting screen.

① Global fixed IP address or fixed domain name on the WAN side of the router

When performing remote control via the Internet, apply in advance to an Internet service provider to obtain a global fixed IP address, or use various DDNS (Dynamic Domain Name System) services to obtain a fixed domain name. When using DDNS, it may be necessary to set the DDNS settings automatically when the dynamic IP address is changed.

② IP address of the router

Example: 192.168.0.1, etc

③ Subnet mask

Example: 255.255.255.0, 255.255.0.0, etc.

④ IP addresses of other devices (other computers, network cameras, etc.) connected to the same router*

If there is a device with the same IP address as SCU-LAN10 in the same network, it will not operate normally.

Example: 192.168.0.2, 192.168.0.3, etc

*Sharing the network with other devices may cause remote control or audio delay, so it is recommended that you do not connect other devices as much as possible.

(2) When connecting directly with an Ethernet cable for remote control

If you connect the FTDX101MP/D and the SCU-LAN10 directly with an Ethernet cable without using a router in the same building, you do not need to check the network environment. Proceed to “② Install the software on a computer” (next page).

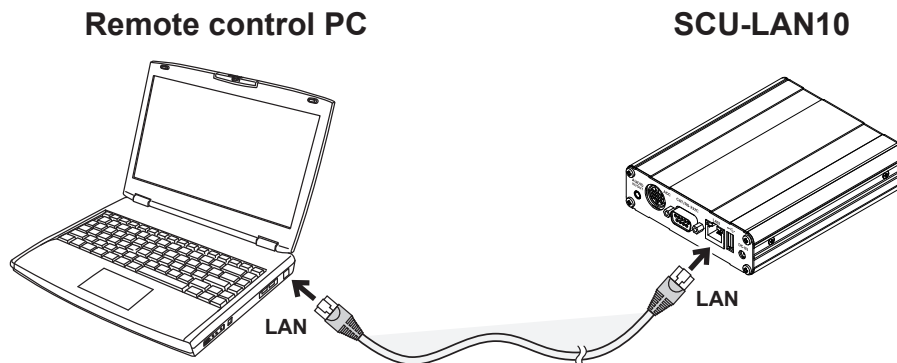

(3) Remote control within the same LAN using a router

When connecting in the same LAN environment using a router such as in a house, check the following three items with reference to the figure.

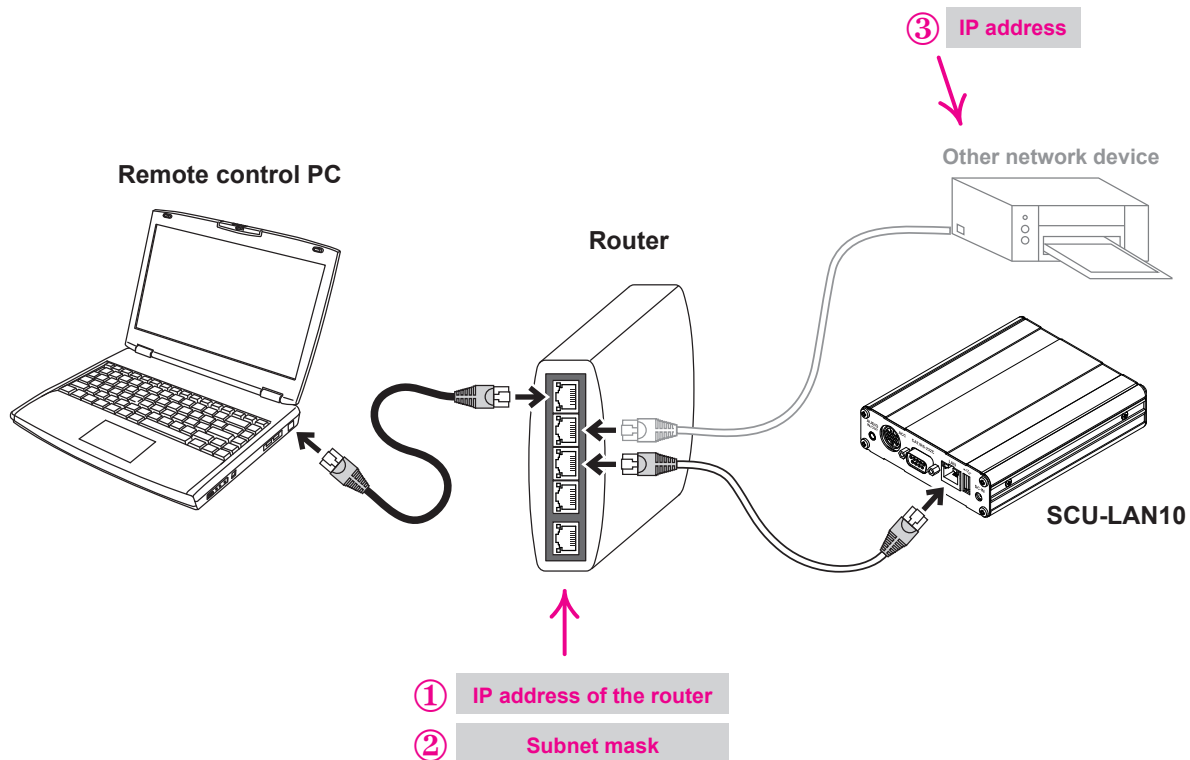

① **IP address of LAN side of the router**

Example: 192.168.0.1, etc

② **Subnet mask**

Example: 255.255.255.0, 255.255.0.0, etc

③ **IP addresses of other devices (other computers, network cameras, etc.) connected to the same router***

Example: 192.168.0.2, 192.168.0.3, etc

*Sharing the network with other devices may cause remote control or audio delay, so it is recommended that you do not connect other devices as much as possible.

② Install the software on a computer

Install the software on the computer that will be used for initial setup and remote control.

※ This step is not necessary if you have already installed the software.

Install Microsoft .NET Framework 4.X

※ Operations on a Windows 10 computer are shown in the procedure below for the purpose of explanation.

Microsoft .NET Framework 4.X is installed in Windows 10 and Windows 8.1 by default. Follow the steps below to confirm that Microsoft .NET Framework 4.X is enabled.

1. Click **[Start]**.
2. Scroll the Start menu and click the Windows System group.
3. Click **[Control Panel]**.
The “**Control Panel**” screen appears.
4. Click **[Programs]**, and then click **[Programs and Features]**.
The “**Programs and Features**” screen appears.
5. Click **[Turn Windows features on or off]**.
“**Windows feature**” screen appears.
6. Make sure that the check box for “**Microsoft .NET Framework 4.X**” is a black box or check mark, and then click the **[Cancel]** button.

If the check box is blank, click the check box to add a black box or check mark, and then click **[OK]**.

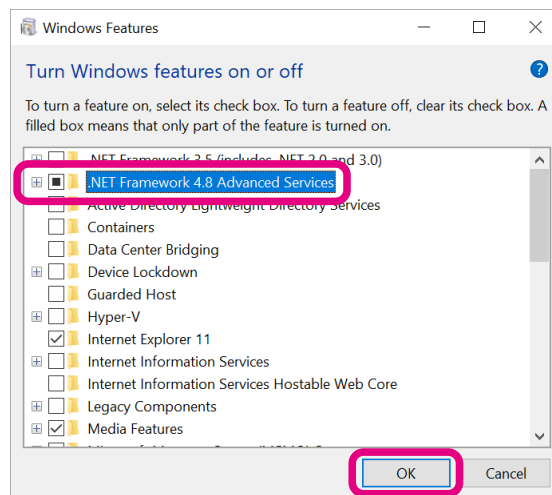

Installation of Microsoft .NET Framework 4.X is completed.

Then proceed to “**Install the Network Remote Control Software**” (Page 11).

Install the Network Remote Control Software

Execute the installer and install the “SCU-LAN10 Network Remote Control Software” and “SCU-LAN10 Setting Tool” on the PC.

Unzip the zip file (SCU-LAN10_Software_V****.zip) downloaded from YAESU website.

The destination folder will be opened automatically.

1. Double-click **[SETUP.exe]** in the folder.

The files are automatically extracted and the “**YAESU SCU-LAN10 Installer**” screen is displayed.



※ If the “**User Account Control**” screen is displayed, click the **[Yes]** button.

2. Click **[Next]**.

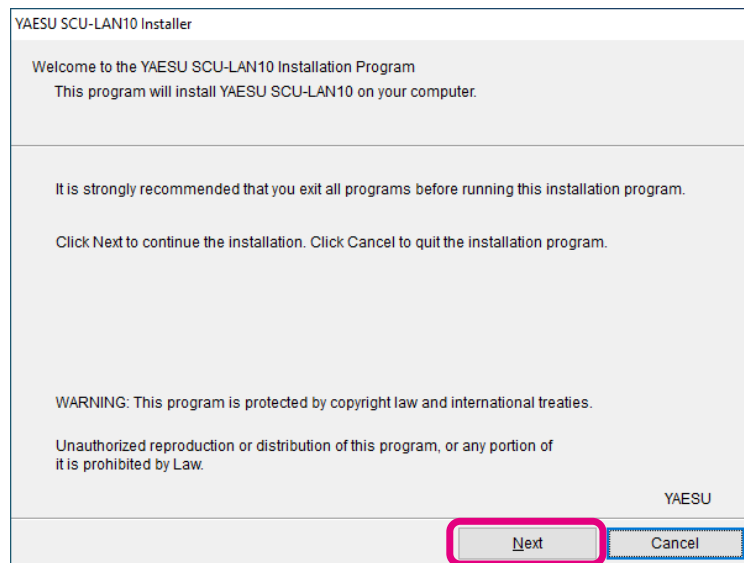

※ If the “**Windows Security**” screen appears, click the **[Install]** button.

3. Click **[Next]**.

To change the installation folder, click the **[Browse]** button and select it.

A confirmation screen for the installation folder appears.

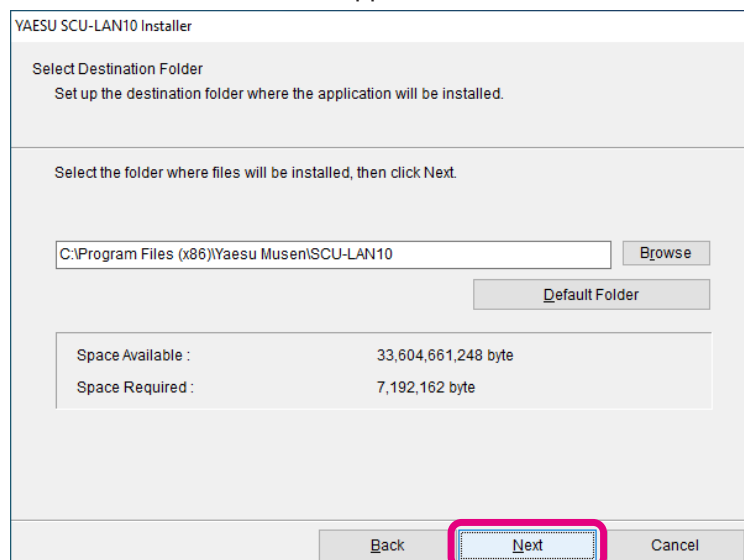

4. After confirming, click the **[Next]** button.

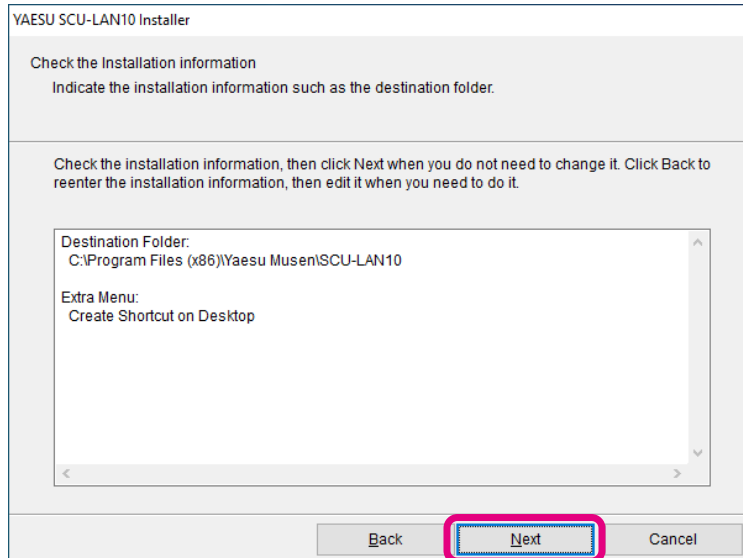

5. If the folder does not exist yet, a confirmation screen will be displayed. To create a new folder, click the **[Yes]** button.

“**SCU-LAN10 Network remote control software**” and “**SCU-LAN10 setting software**” are installed. When the installation is complete, “**Congratulations!**” Will be displayed.

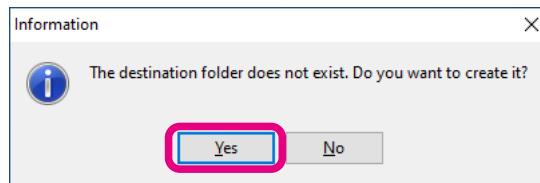

6. Click **[Finish]**.

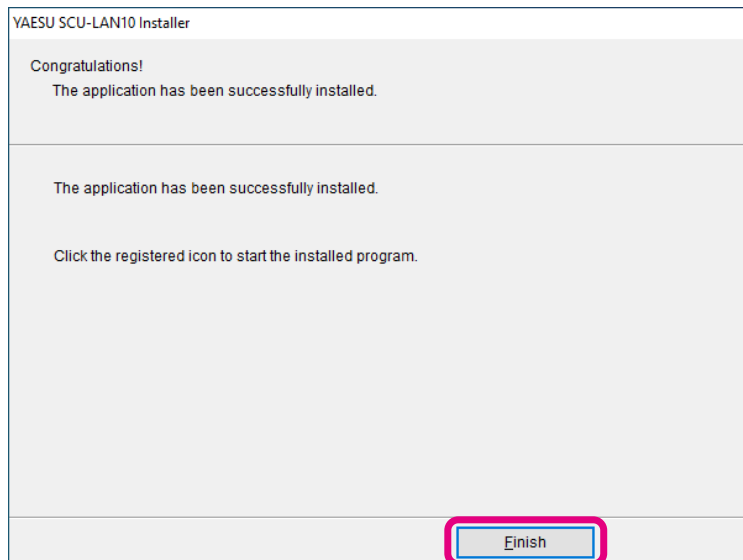

Installation of “**SCU-LAN10 Network Remote Control Software**” and “**SCU-LAN10 Setting Software**” is completed.



If the computer used for the initial settings of SUC-LAN10 and the computer used for remote control are different, install the required software on both computers using the same procedure.

③ Preparation for initial setting

Connect device

For initial setting, refer to the figure and connect the PC and the SCU-LAN10 directly with a commercially available straight Ethernet cable.



- It is recommended to connect the PC and SCU-LAN10 directly with an Ethernet cable as shown in the figure without using a router for the initial setting.
- Initial settings cannot be made via the Internet, so make initial settings before installing the transceiver and SCU-LAN10.

1. Turn the transceiver **OFF**.
2. Refer to the figure and connect the SCU-LAN10 directly to your computer with a commercially available straight Ethernet cable.
3. Connect the SCU-LAN10 and FTDX101MP / D with the included ACC cable and USB cable.

Network settings of PC used for initial setting (example)
IP address: 192.168.49.10
Subnet mask: 255.255.255.0

SCU-LAN10 (Factory default settings)
IP address: 192.168.49.1
User: defaultuser
Password: defaultuser

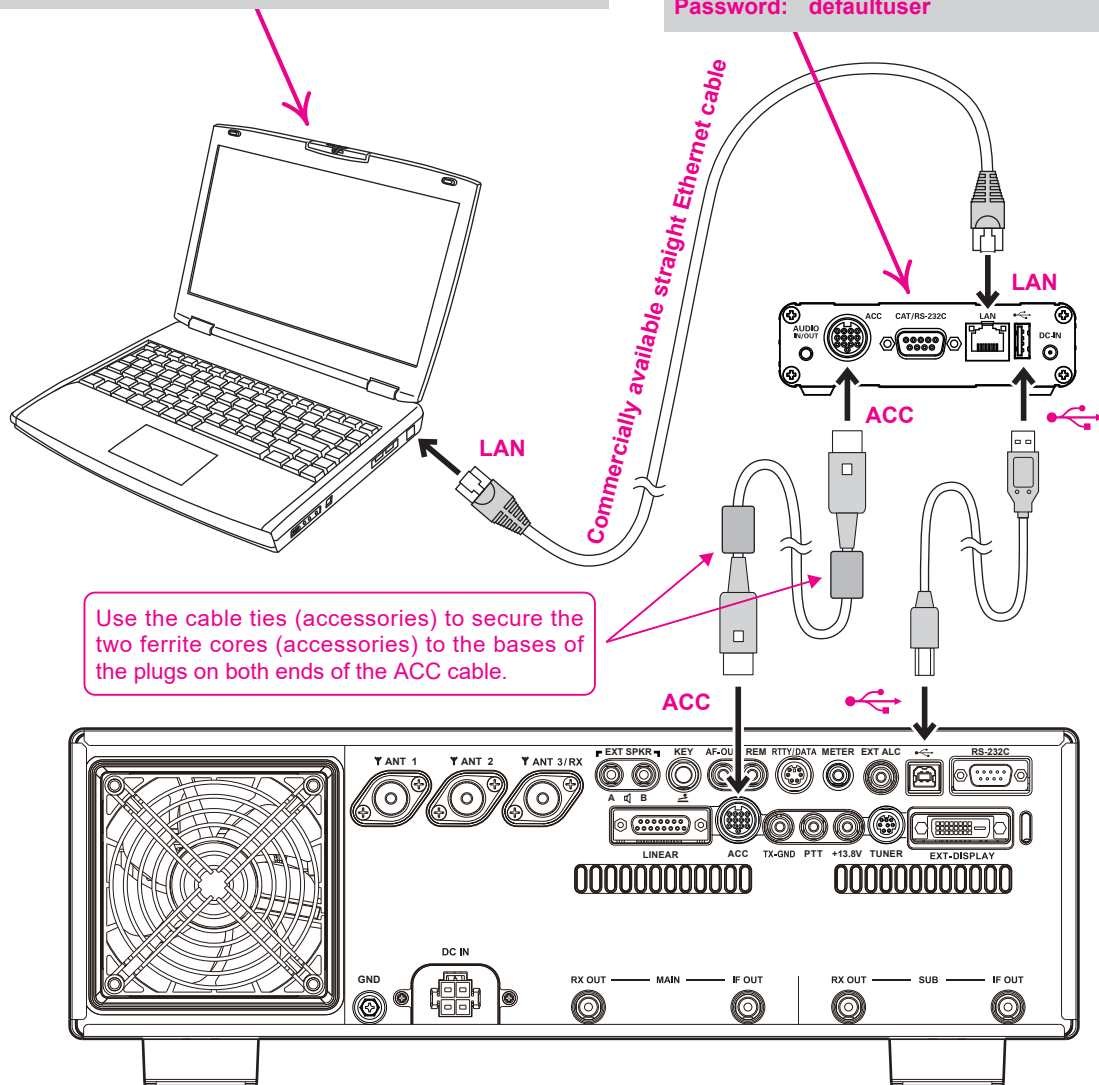

Temporarily change the PC network settings

It is necessary to temporarily change the network settings of the PC that is connected to SCU-LAN10 and used for the initial settings.



When you change the network settings, you may not be able to connect to the Internet or network devices from your computer, so restore the settings at the end of this procedure.

※ Operations on a Windows 10 computer are shown in the procedure below for the purpose of explanation.

1. Right-click [Start] and click [Network Connections].



2. Click [Change adapter options].

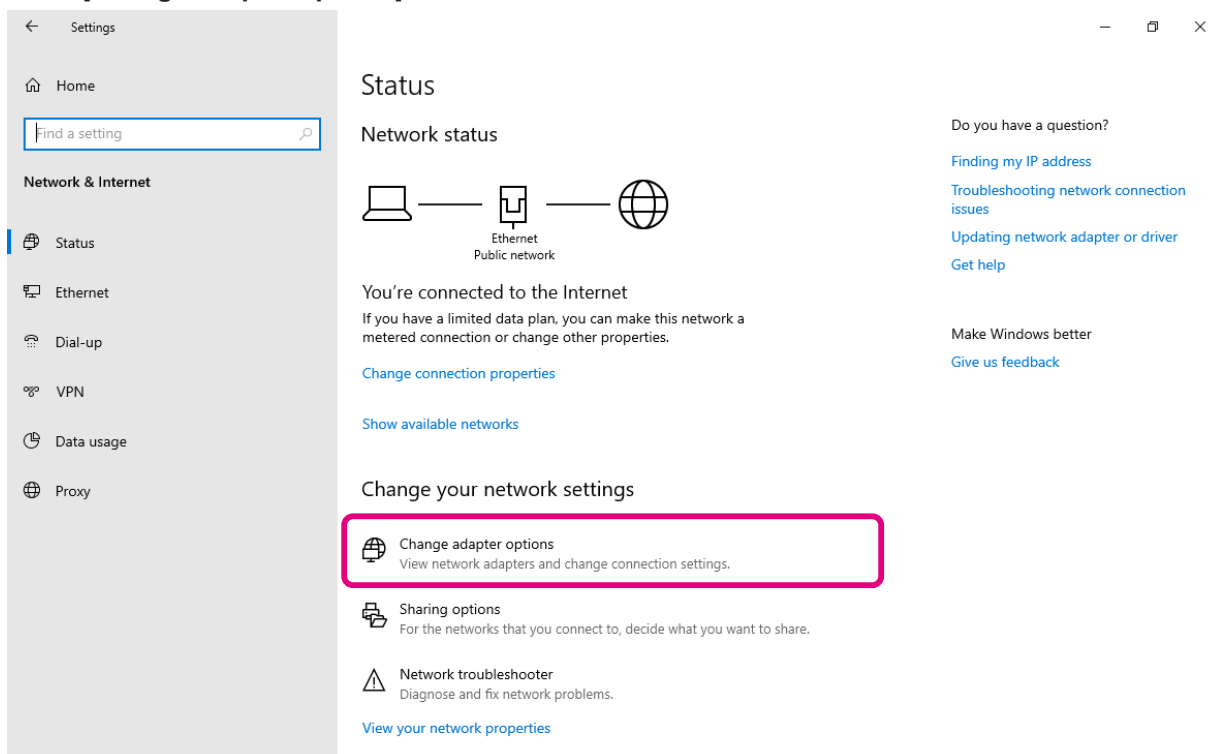

3. Double-click the network adapter (LAN card) connected to SCU-LAN10.
The “Ethernet status” screen is displayed.

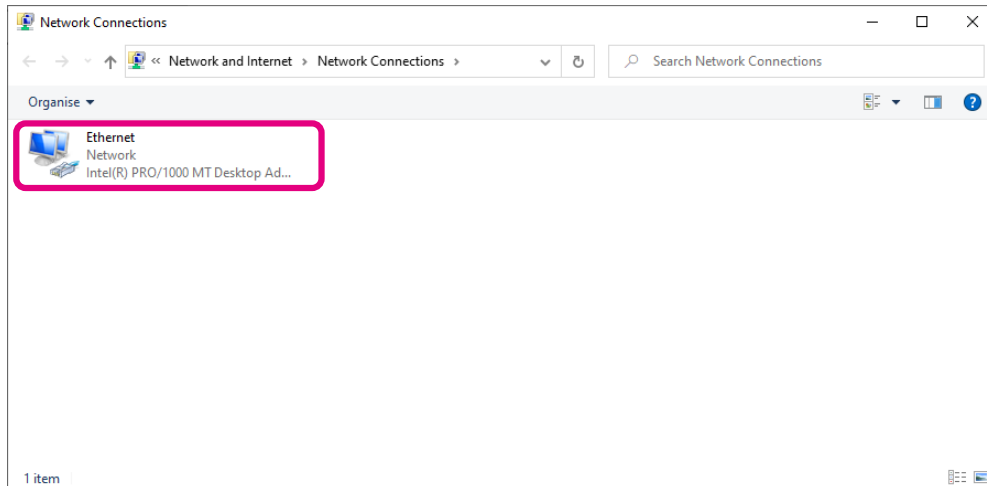

4. Click [Properties].

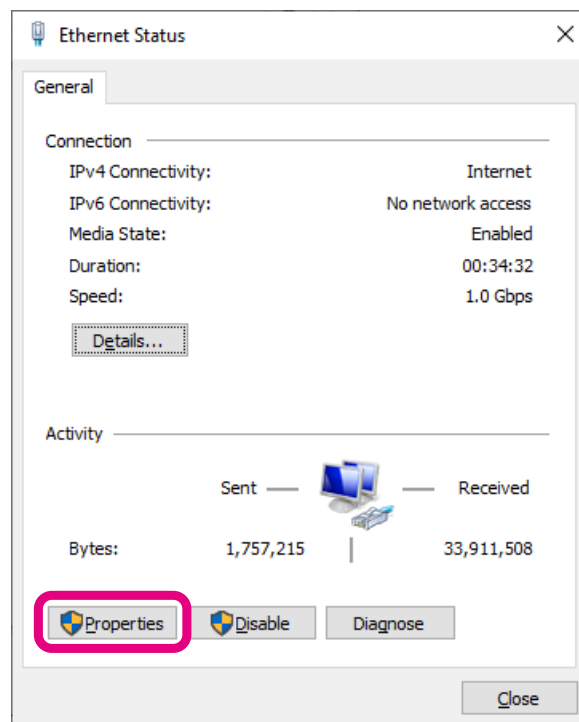

- Click [Internet Protocol Version 4 (TCP/IPv4)], and then click [**Properties**].
 “**Internet Protocol Version 4 (TCP/IPv4) Properties**” screen appears.
 ※ Please note that “Internet Protocol Version 6 (TCP/IPv6)” cannot be used.

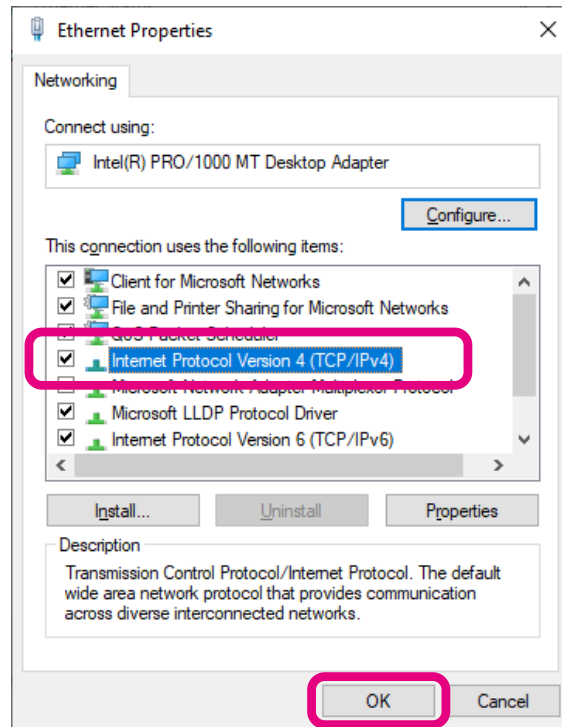

- Make a note of all the settings below before making any changes to restore the network settings after completing the settings.

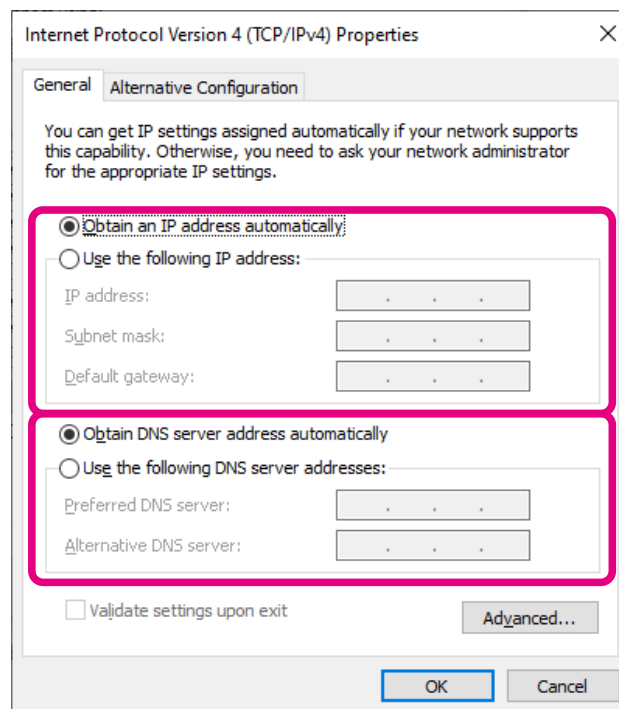

7. Change the settings as follows.
 - (1) Click [**Use the following IP address**] to add a black circle.
 - (2) Set the IP address to “**192.168.49.10**”.
 - (3) Set the Subnet mask to “**255.255.255.0**”.



- Leave the Default gateway field blank.
- It is automatically changed to “Use the following DNS server addresses”. No DNS server settings are required.

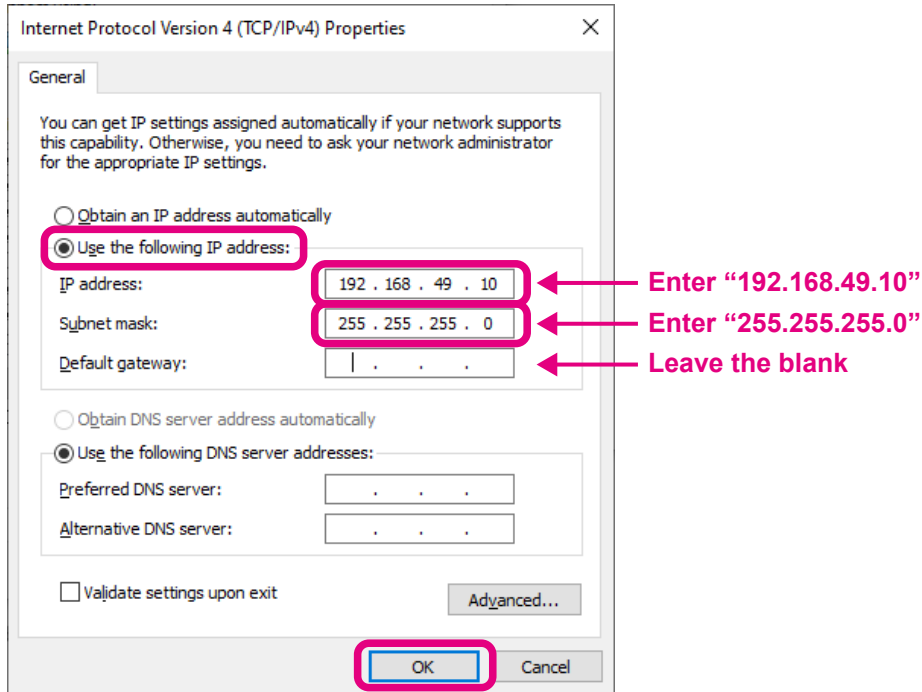

8. Click [**OK**].
 9. Close unnecessary Windows screens.
- The network settings of the PC for initial setting of SCU-LAN10 is completed.

④ Setting the SCU-LAN10

Start the setting software “**SCU-LAN10 Setting Tool**” and perform the initial setting of SCU-LAN10 from a personal computer.

※ The following procedure uses Windows 10 operations as an example.

1. Turn the transceiver **ON**.

Make sure that only the POWER indicator (green) on the SCU-LAN10 is blinking. (It takes about 12 seconds.)

2. Click the Windows **Start** button and click the [**YAESU SCU-LAN10 Setting Tool**] icon in the “**Yaesu Muse**” group to start the setting software.



The initial login screen is displayed.



You can also double-click the [**YAESU SCU-LAN10 Setting Tool**] icon on the desktop to start the setting software.

3. When setting the SCU-LAN10 for the first time, enter the following and click the [**Login**] button.

IP Address: 192.168.49.1 (Automatically entered)

User: defaultuser (Automatically entered)

Password: defaultuser (Enter the same “defaultuser” as User)

※ When logging in for the first time or later, enter the previously set value.

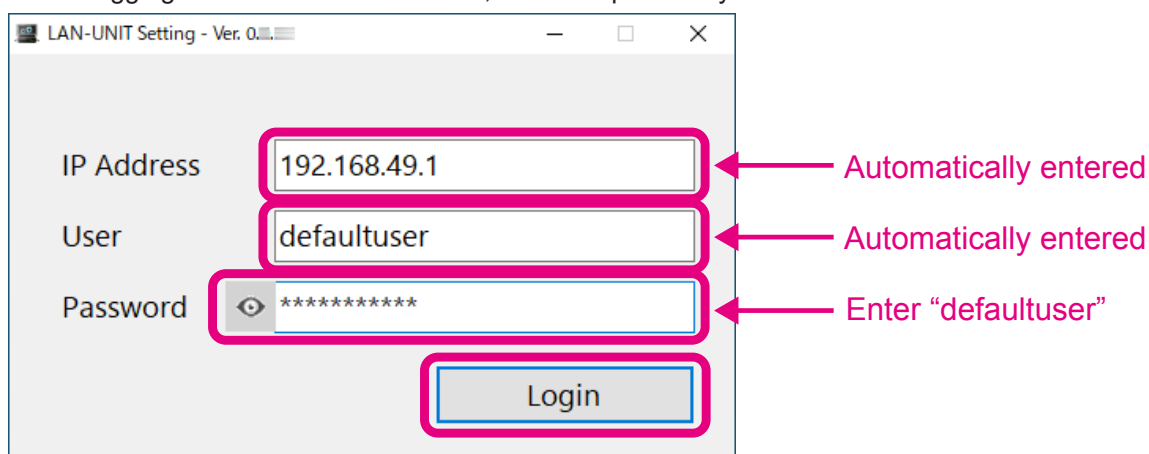

- If you log in successfully, the “**New Account**” screen will be displayed automatically only for the first time.
- If “**login error!**” is displayed, the password may not have been entered correctly, or the computer's network settings may be incorrect. Also, check the connection between the PC and the LAN cable of SCU-LAN10.
- If the settings saved in SCU-LAN10 are lost after the second time, reset SCU-LAN10 and start over from step 3. If “login error!” is still displayed, check the communication status by referring to “**Confirmation procedure of network communication with SCU-LAN10 by ping (pin) command**” (Page 19).



To reset the SCU-LAN10. Press and hold the [**RESET**] button on the front panel of the SCU-LAN10 with the thin-tipped bar for about 5 seconds until only the STATUS indicator (red) blinks. Please note that resetting will restore the SCU-LAN10 settings to the factory default settings.

● **Confirmation procedure of network communication with SCU-LAN10 by ping (pin) command**

- (1) Click **Start** at the bottom left of the Windows screen.
- (2) Scroll the Start menu and click the “**Windows System**” group.
- (3) Click [**Command Prompt**].
The “Command Prompt” screen is displayed.
- (4) Enter “**ping 192.168.49.1**” (for SCU-LAN10 set at the factory) and press the **Enter** key.
“**Reply from 192.168.49.1:**” is displayed, network communication is normal.
If “**Reply from 192.168.49.1:**” is not displayed, refer to “③ **Preparation for initial setting**” (Page 13) and recheck the device connection and network settings of the PC.

4. On the “**New Account**” screen, set “**User**” and “**Password**” for future remote control.
User (Alphabet or number from 4 to 32 alphanumeric characters and some symbols*)
Password (Alphabet or number from 10 to 32 alphanumeric characters and some symbols*)
*:Uppercase and lowercase letters are distinguished.
※ Be sure to make a note of the set User and Password.

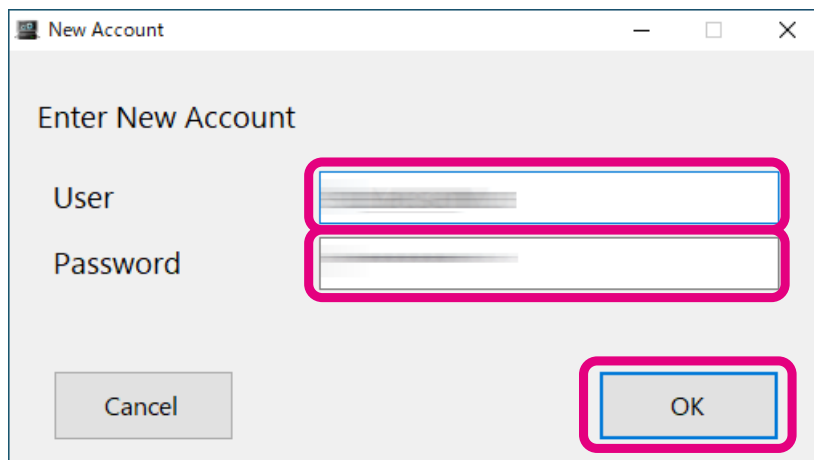

5. Click the [**OK**] button.
6. When the setting is completed, “**Success.**” Is displayed. Click the [**OK**] button.
Then the login screen is displayed.
7. The set User and Password are automatically entered, so click [**Login**].
A screen for configuring SCU-LAN10 opens.

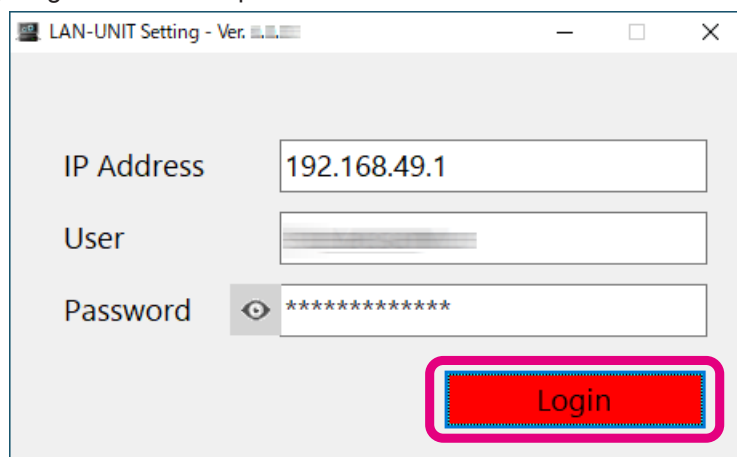

8. Set it according to the network environment of the place where SCU-LAN10 and the transceiver are actually installed, which was confirmed in “① **Check the LAN for installing the transceiver**” (Page 8)
The following three connection examples are explained, so please refer to the diagram that applies to your installation.

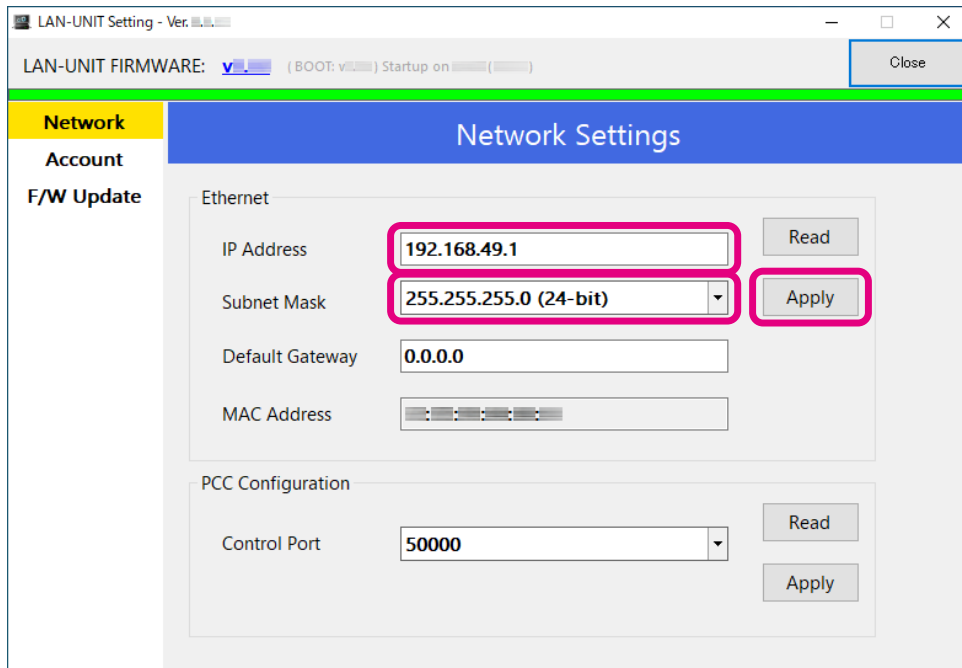

(1) For remote control via the Internet

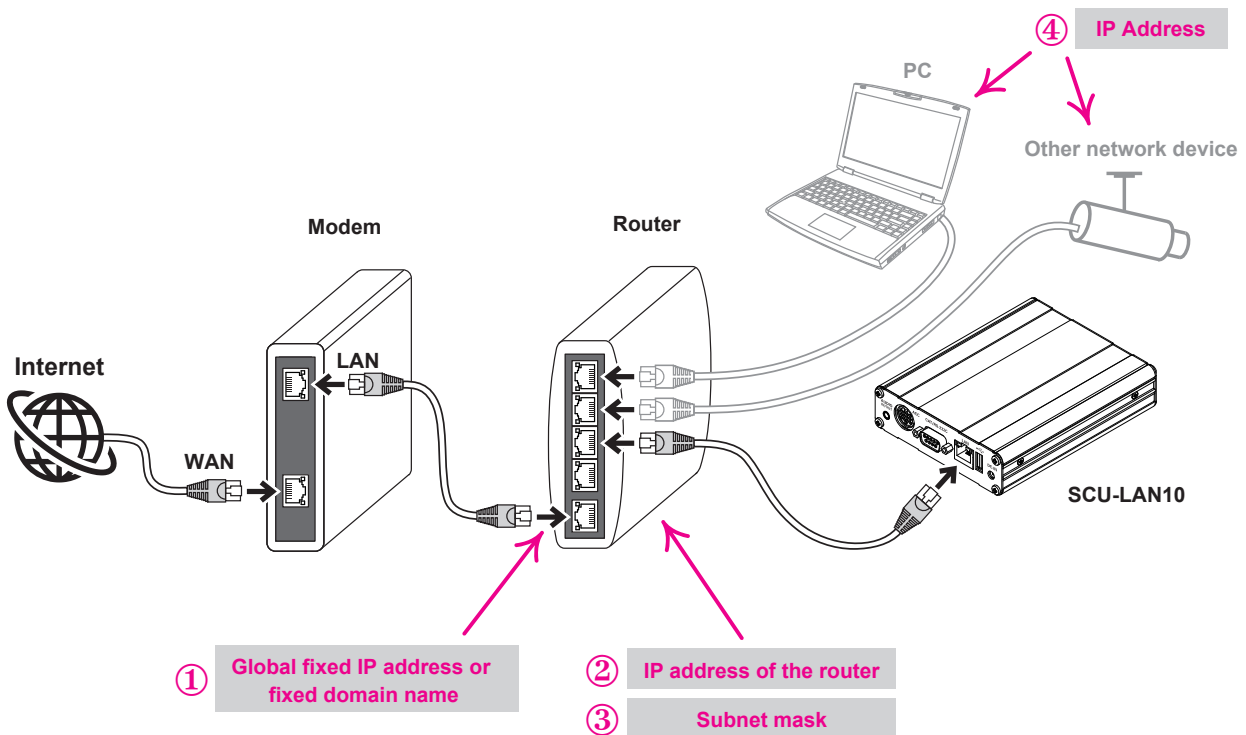

Set according to the following network environment confirmed in “① **Check the LAN for installing the transceiver**” (Page 8). Check the LAN for installing the transceiver.

- ① **WAN side global fixed IP address or fixed domain name**
- ② **IP address of LAN side of router**
- ③ **Sub-net mask LAN**
- ④ **IP address of another device (PC, network camera, etc.) connected to the same router**

(1) Setting an "IP Address"

- Set an IP address other than "② IP address of LAN side of router" and "④ IP address of another device connected to the same router". (*Note that this is not a global fixed IP address on the WAN side.)
- If the subnet mask is "255.255.255.0", the range of IP addresses that can be used are from "192.168.xxx.2" to "192.168.xxx.254" but the IP address that may be set automatically by the DHCP function of the router is recommended to set it outside the range. For general routers, we recommend setting the IP address in the range of "192.168.xxx.65" to "192.168.xxx.254".

Example: 192.168.0.100

(2) Setting "Subnet Mask"

Set the same as "③ Sub-net mask LAN"

Example: 255.255.255.0 or 255.255.0.0 etc.

(3) Setting a "Default Gateway" (When using a router only)

Set the same as "② IP address of LAN side of router"

Example: 192.168.0.1

※ "Control Port" usually does not need to be changed. If it conflicts with other software, it can be changed within the range of 49990 to 50009. (default value: 50000)

(4) Go to step 9 on the next page

(2) When connecting directly with a LAN cable for remote control

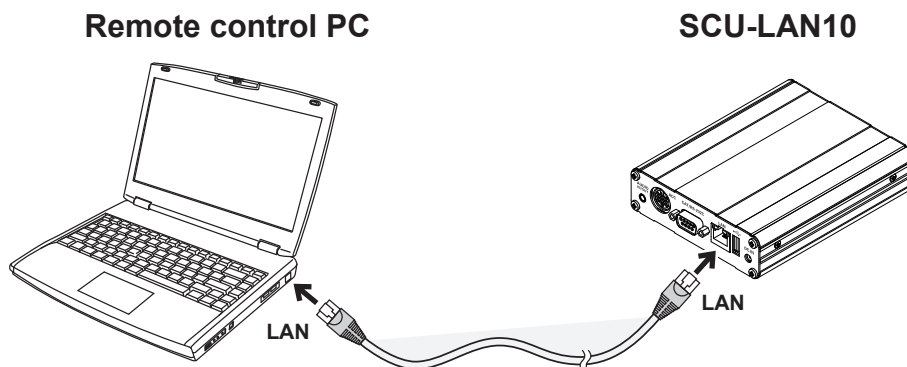

(1) Setting an "IP Address"

Set an IP address other than the computer's IP address. Generally, set as follows.

Example: 192.168.0.100

(2) Setting a "Subnet Mask"

Any setting can be used, but generally set as follows.

Example: 255.255.255.0

(3) No "Default Gateway" setting is required.

It is "0.0.0.0" and does not need to be changed.

※ "Control Port" usually does not need to be changed. It can be changed within the range of 49990 to 50009. (default value: 50000)

(4) Press **[Apply]** button to save the settings.

(5) A confirmation screen is displayed. Click **[OK]**.

(6) Go to step 9 on the next page

(3) Remote control within the same LAN using a router

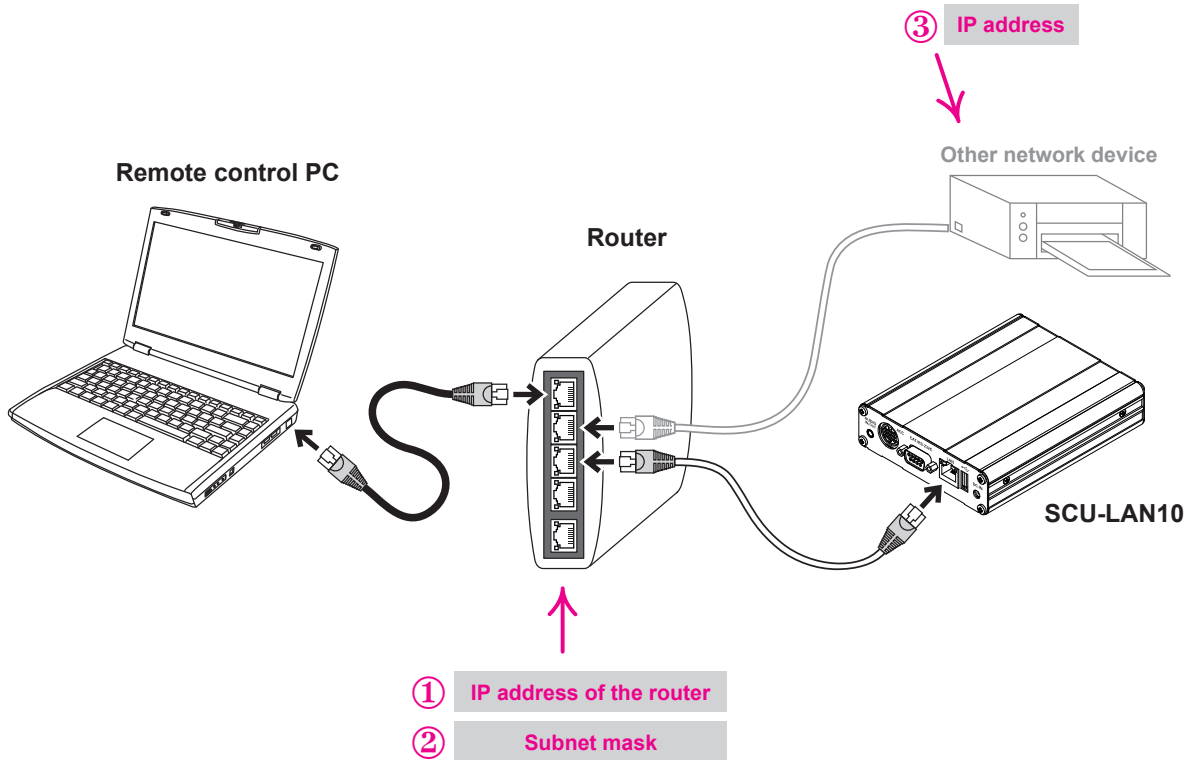

Set according to the following network environment confirmed in “① Check the LAN for installing the transceiver”.

① IP address of LAN side of the router

② Subnet mask

③ IP addresses of other devices (other computers, network cameras, etc.) connected to the same router

(1) Set the “IP Address”

- Set an IP address other than (1) IP address of router and (3) IP address other than network device.
- If the subnet mask is “**255.255.255.0**”, the IP address range from “**192.168.xxx.2**” to “**192.168.xxx.254**” can be used, but the range of IP address that may be automatically set by the DHCP function of the router. It is recommended to leave it outside. For general routers, we recommend setting the IP address in the range of “**192.168.xxx.65**” to “**192.168.xxx.254**”.

Example: 192.168.0.100

(2) Set the “Subnet Mask”

Set the same as the confirmed “② Subnet mask”.

Example: 255.255.255.0, 255.255.0.0

(3) Set “Default Gateway” (only when using a router)

Set the same IP address as the one you have checked “③ Router IP address”.

Example: 192.168.0.1

※ Normally you do not need to change the “Control Port”. If it conflicts with other software, it can be changed within the range of 49990 to 50009. (Factory setting: 50000)

9. Click [Apply] to save settings.

The confirmation screen will be displayed.

10. Click **[OK]**.

Note

At this time, if the setting environment and the actually used network environment are different, the connection between the setting software and SCU-LAN10 will be disconnected, but this is normal.

12. Click **[Close]** at the top right of the screen to close the screen.

Initial settings are complete.

Proceed to “⑤ **Restore the network settings of the computer**” (Page 25).

Other functions of SCU-LAN10 Setting Tool

● Account Settings Screen

Configure the account settings for remote control.

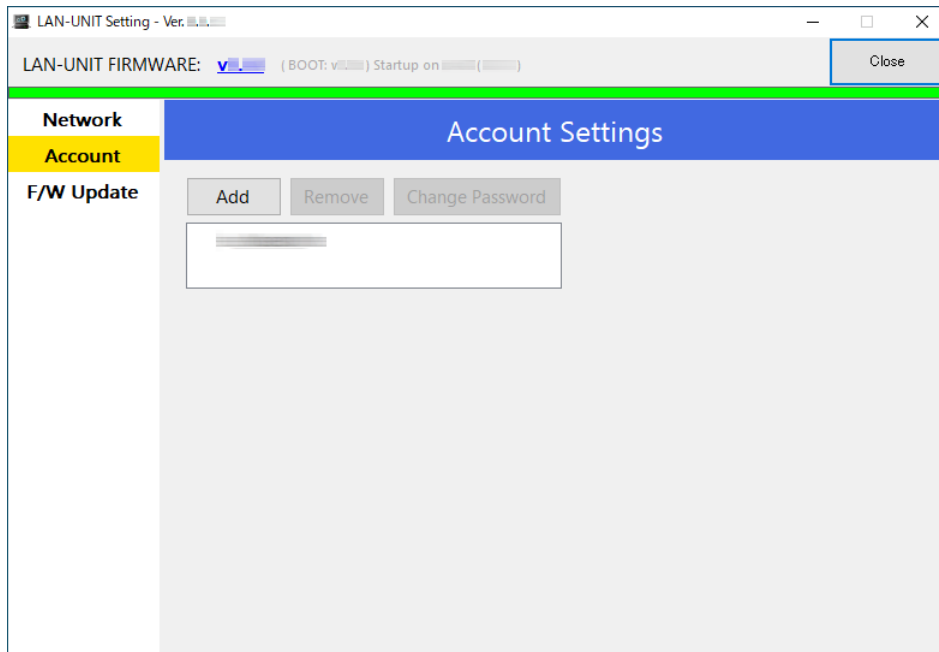

Add

Add the account used for remote control. You can register up to two accounts.

1. Click **[Add]**.

The new account settings screen is displayed.

2. Enter “**User**” (4 to 32 alphanumeric characters and some symbols*) and “**Password**” (10 to 32 alphanumeric characters and some symbols*) and click **[OK]**.

*Uppercase and lowercase letters are distinguished.

The new account will be saved.

Remove

Delete the account.

1. Click the account you want to delete.

2. Click **[Remove]**.

A confirmation screen is displayed.

3. Click **[OK]**.

The account will be deleted.



If you delete both accounts, it will revert to the default account (User: defaultuser, Password: defaultuser).

Change Password

Change account password.

1. Click the account whose password you want to change.
2. Click [**Change Password**].
The new password setting screen is displayed
3. Enter the “**password**” (10 to 32 alphanumeric characters and some symbols*) and click [**OK**].

*Uppercase and lowercase letters are distinguished

The new password will be saved.

● F/W Update screen

When the firmware of SCU-LAN10 is updated, the firmware will be downloaded from YAESU website and updated. Updates can be done remotely via the Internet or LAN.

※ For details on the update operation, refer to the update manual attached to the SCU-LAN10 firmware.

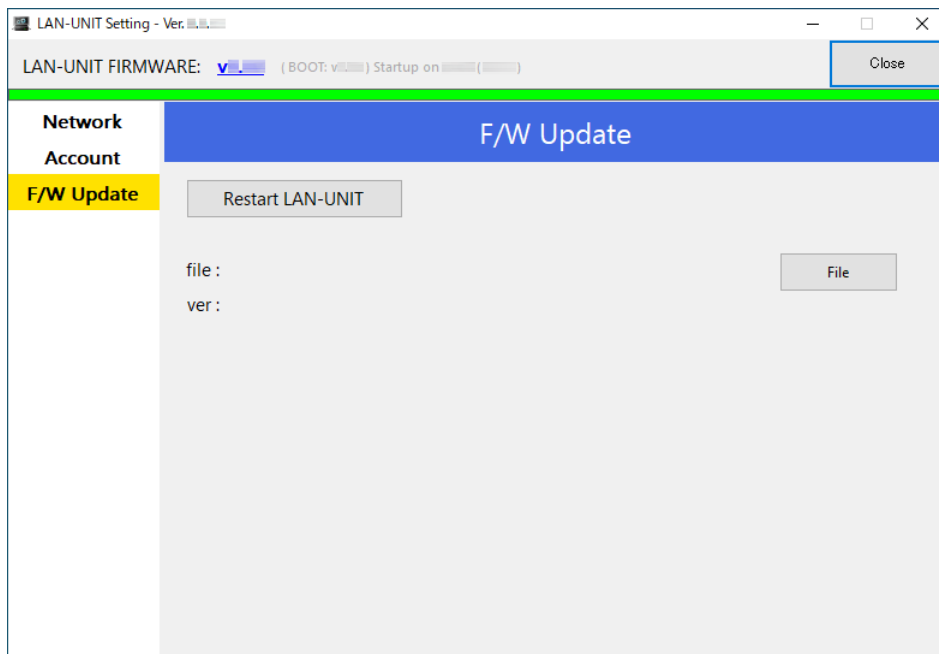

⑤ Restore the network settings of the computer

After completing the initial settings of SCU-LAN10, restore the network settings of the personal computer.



If you do not restore the settings, you may not be able to connect to the Internet or network devices from your computer.

※ The following procedure uses Windows 10 operations as an example.

1. Right-click [**Start**] at the bottom left of the Windows screen, and click [**Network Connections**].

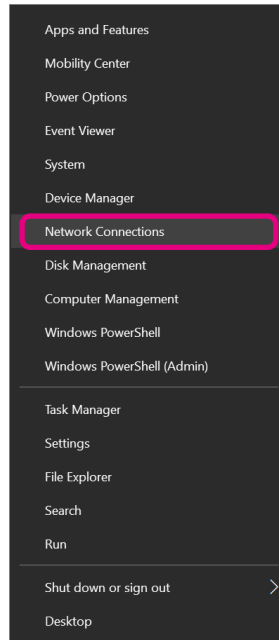

2. Click [**Change adapter options**].

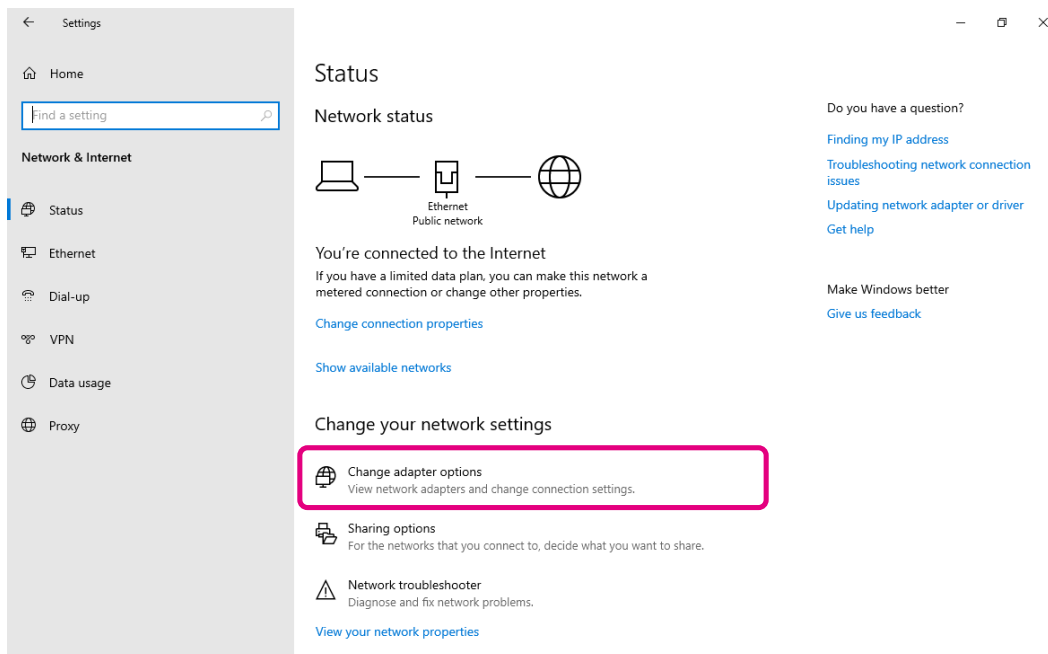

3. Double-click the network adapter (LAN card) to which SCU-LAN10 is connected.
The “Ethernet status” screen is displayed.

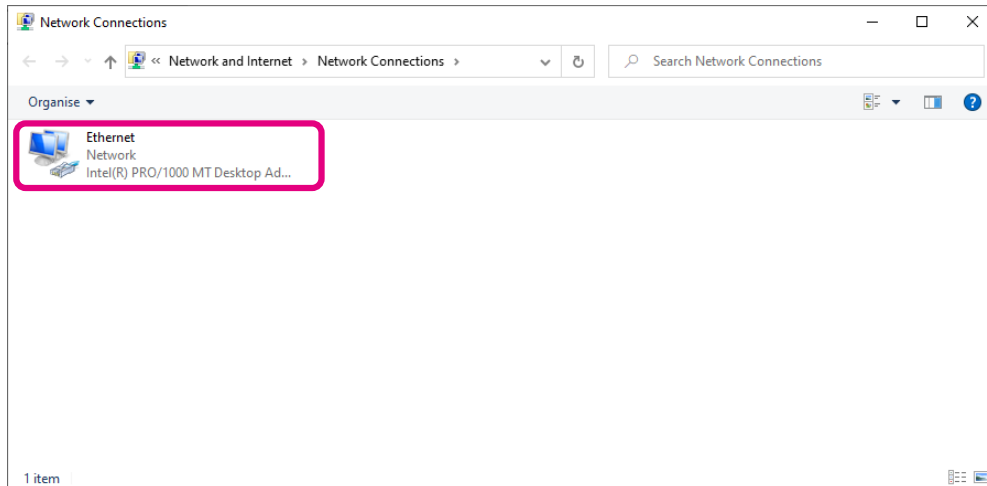

4. Click [Properties].

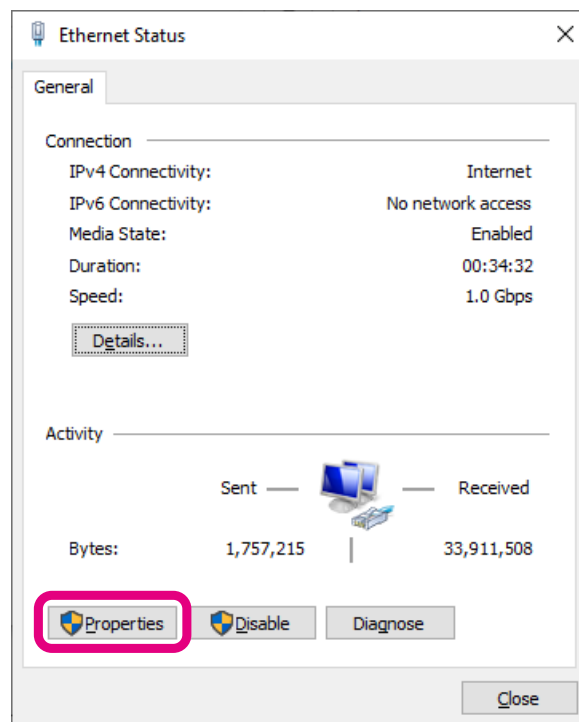

5. Click [Internet Protocol Version 4 (TCP/IPv4)], and then click [**Properties**].
“**Internet Protocol Version 4 (TCP/IPv4) Properties**” screen appears.

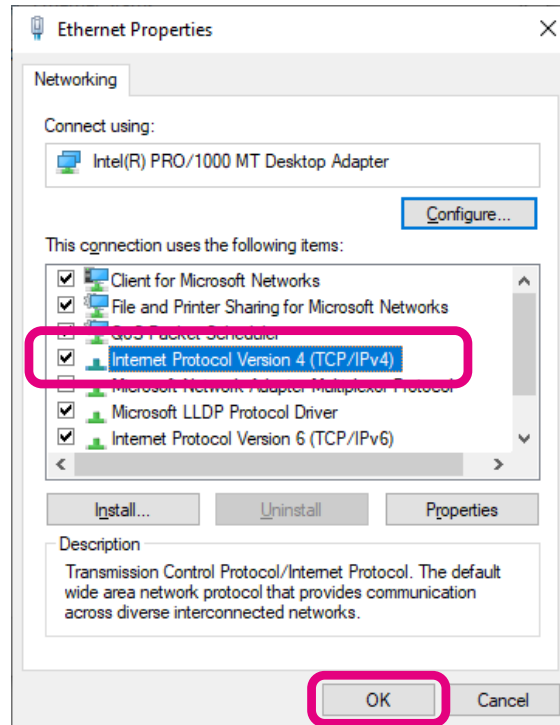

6. Set the LAN environment as it was in step 6 of “Temporarily change the PC network settings” (Page 14) before the change.
× If it was set to “**Obtain DNS server address automatically (B)**” before changing, it is automatically changed to “**Use the next DNS server address (E)**” So don't forget to bring it back.

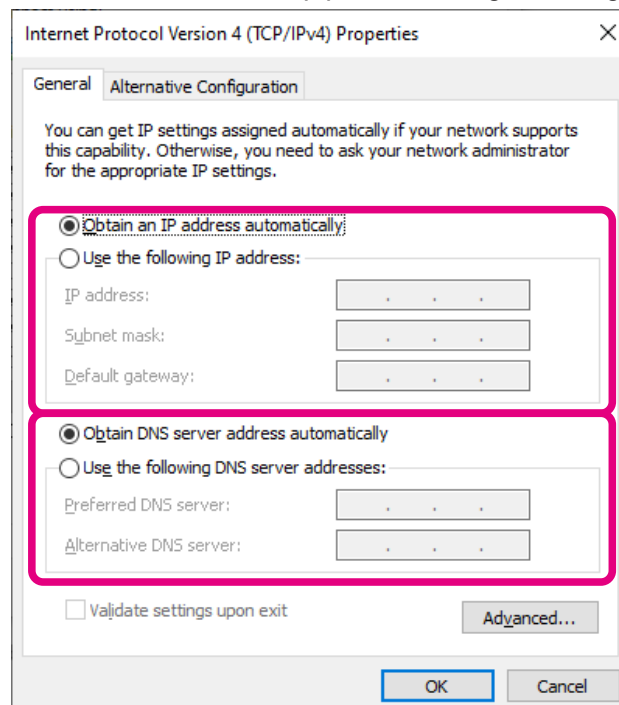

7. Click [**OK**] bottom.
8. Close any open windows that you don't need.
This completes the work of restoring the network settings of the PC.

⑥ Initial setting of FTDX101MP/D

Set the FTDX101MP/D in advance as follows for remote control. All the following settings are required for normal remote control. Please refer to “**FTDX101MP/D setting menu operation procedure**” (Next page) for the setting operation of FTDX101MP/D.

Settings for transmit audio

Change the transmit audio setting for each mode to **SOURCE: REAR, REAR SELECT: USB**.

SSB

RADIO SETTING → MODE SSB → SSB MOD SOURCE: REAR

RADIO SETTING → MODE SSB → REAR SELECT: USB

AM

RADIO SETTING → MODE AM → AM MOD SOURCE: REAR

RADIO SETTING → MODE AM → REAR SELECT: USB

FM

RADIO SETTING → MODE FM → FM MOD SOURCE: REAR

RADIO SETTING → MODE FM → REAR SELECT: USB

CAT Rate setting

Set the communication baud rate of CAT to 38400bps.

OPERATION SETTING → GENERAL → CAT RATE: 38400(bps)

CAT TIME OUT TIMER setting

Set the CAT TIME OUT TIMER setting to 10 (msec)

OPERATION SETTING → GENERAL → CAT TIME OUT TIMER: 10 (msec)

CAT RTS setting

Set the CAT RTS setting to ON.

OPERATION SETTING → GENERAL → CAT RTS: ON

VOX SELECT setting

Set VOX Select to DATA.

OPERATION SETTING → TX GENERAL → VOX SELECT: DATA

TOT (Time Out Timer) setting

It is recommended to set the transmit timeout timer function in case the transceiver remains in the transmit state for some reason.

OPERATION SETTING → GENERAL → TX TIME OUT TIMER: 1(min) - 30(min)

- **FTDX101MP/D setting menu operation procedure**

1. Press the **[FUNC]** key.
2. Touch the category item you want to set.
Or turn the **[MULTI]** knob to select a category item and press the **[MULTI]** knob.

Comprehensive settings such as: Transmit & Receive, Interference Reduction, Memory, Scan, etc.

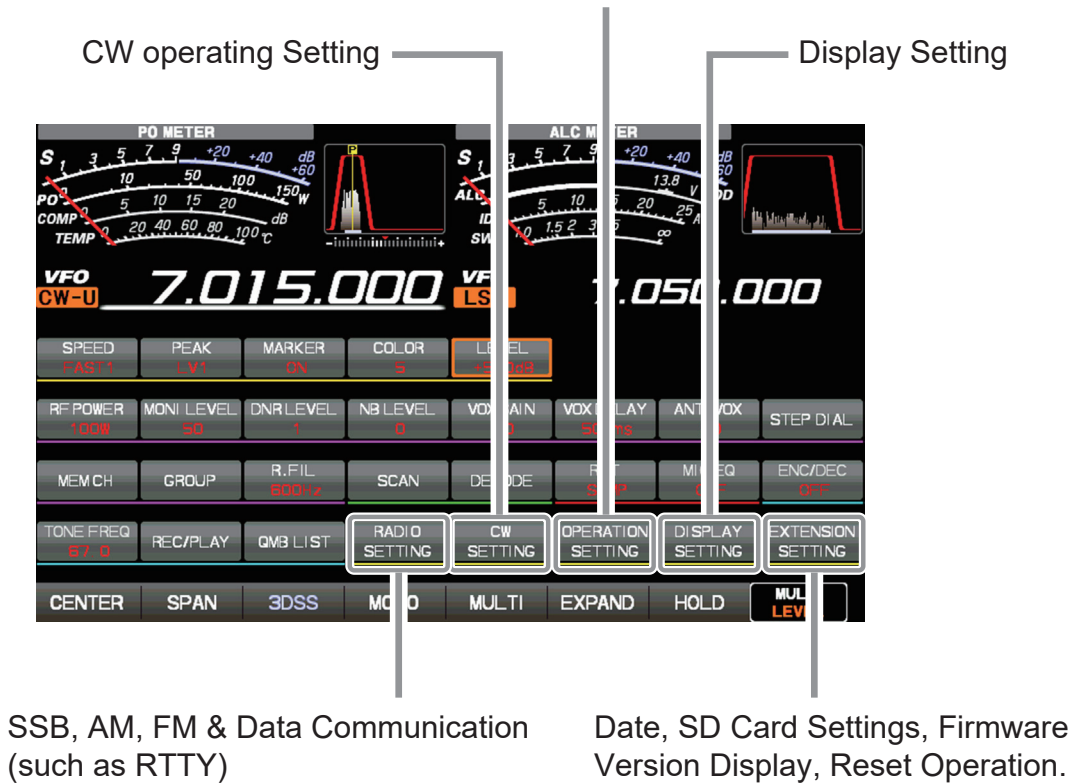

SSB, AM, FM & Data Communication (such as RTTY)

Date, SD Card Settings, Firmware Version Display, Reset Operation.

3. Touch the item to set.
4. Rotate the **[MULTI]** knob to select the item setting you want to change, and touch the item.
5. Either touch the desired setting or turn the **[MULTI]** knob to change the setting.
6. Press the **[FUNC]** key to save the setting and return to the function screen.
7. Press the **[FUNC]** key to return to the normal operation screen.

The setting of the FTDX101MP/D is completed.

If you do not use a router, proceed to “**Remote connection**” (Page 31).

⑦ Open UDP port of router

When using a router or firewall in the LAN environment where the transceiver and SCU-LAN10 are installed, it is necessary to open the UDP (User Datagram Protocol) port (permit communication).

By default, the following 4 UDP ports are used.

50000, 50001, 50002 and 50003

The name of the function in the router that opens the port differs depending on the company, and includes “Port translation”, “Port forwarding”, “IP masquerade”, “NAT address translation”, etc.

In general, use a web browser such as Internet Explorer on your computer to access the IP address of the router itself to set the settings, or use the dedicated setting software provided by the router manufacturer to set the settings.

For the setting method, refer to the instruction manual of your router.

Setting Example

Open the router setting screen

1. Start a web browser (such as Internet Explorer) on your computer.
2. Enter “192.168.***.***” (default value) in the address field and press the **[Enter]** key on your computer.



The initial value of the IP address of the router for displaying the setting screen varies depending on the product of each company.

IP address examples: 192.168.11.1, 192.168.0.1, 192.168.10.1, 192.168.1.1, 192.168.12.1, etc.

The login screen is displayed.

3. Enter “*****” (user name) as the user name.
4. Enter “*****” (password) in the password field.



The initial values for the user name and password differ depending on the product of each company.

Example user name: admin, root, etc.

Password examples: None (Enter only), password saved the first time, admin, password, etc.

Set the UDP port to open

1. Click the “**Port conversion**” function from the menu.
2. Set the following contents.
 - Protocol: TCP/UDP
 - Port number: “**50000**”
 - LAN side IP address: IP address set in SCU-LAN10 (example: 192.168.0.100)
3. Save the settings.
4. Repeat steps 2 - 3 to add the next port to the table.
 - 50001
 - 50002
 - 50003
5. Confirm that 4 ports from 50000 to 50003 are set.
6. Close the web browser.

⑧ Remote connection

Install the SCU-LAN10 and FTDX101MP/D

Install the SCU-LAN10 and FTDX101MP/D according to the network environment of the installation location referring to the diagram.

1. Turn the transceiver **OFF**.
2. Connect the SCU-LAN10 to a router or computer with a commercially available straight LAN cable.
3. Connect the SCU-LAN10 and FTDX101MP/D with the included ACC cable and USB cable.
× Attach the two included ferrite cores to the bases of the connectors on both ends of the ACC cable using the cable ties (accessory).

(1) Connection diagram for remote control via the Internet

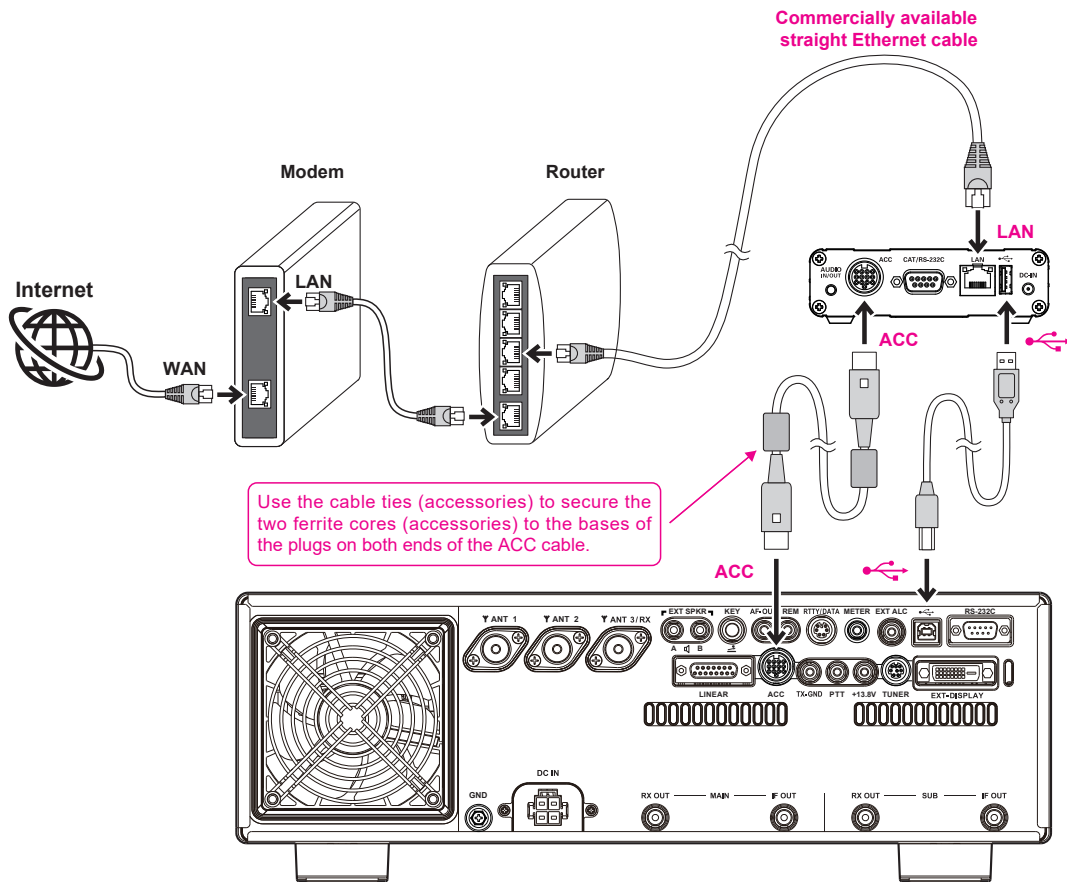

(2) Connection diagram when connecting directly with a LAN cable and performing remote control

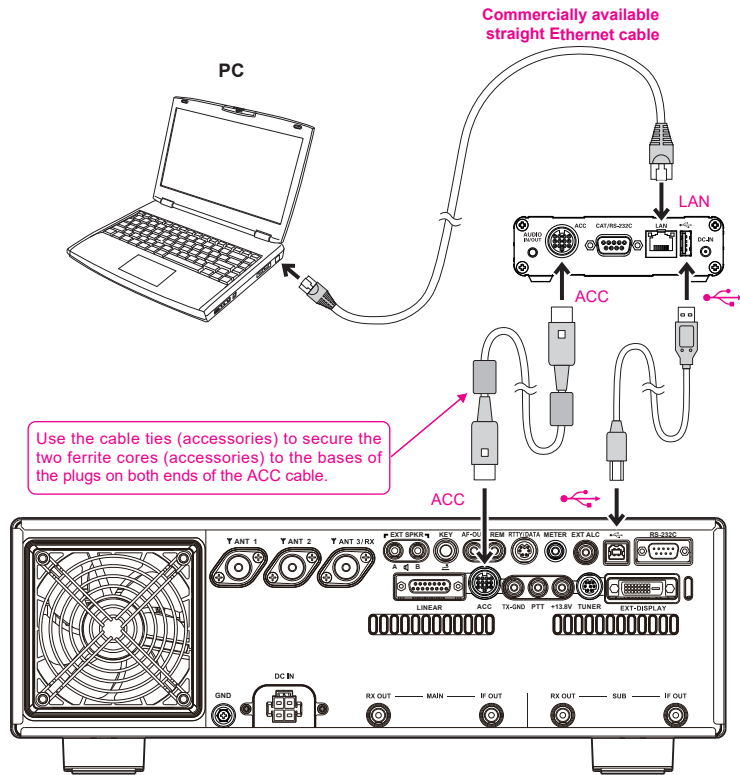

(3) Connection diagram for remote control within a local LAN using a router

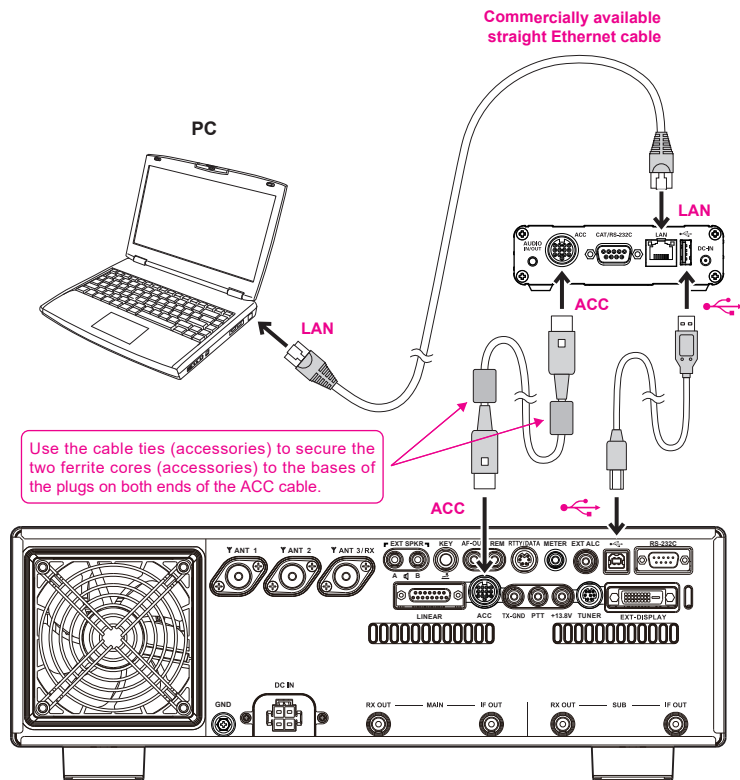

1. Turn the transceiver **ON**.
Confirm that only the POWER indicator (green) of SCU-LAN10 is in the state of blinking. (It takes about 12 seconds.)

Initial settings for remote control software

Start the remote control software “SCU-LAN10 Network Remote Control Software”.

1. Click the Windows **Start** button, and then click the [YAESU SCU-LAN10] icon in the “Yaesu Musen” group to start the remote control software.

When connecting to SCU-LAN10 for the first time, the “**Connection Setup**” screen will be displayed automatically.



You can also double-click the [YAESU SCU-LAN10] icon on the desktop to start the remote control software.

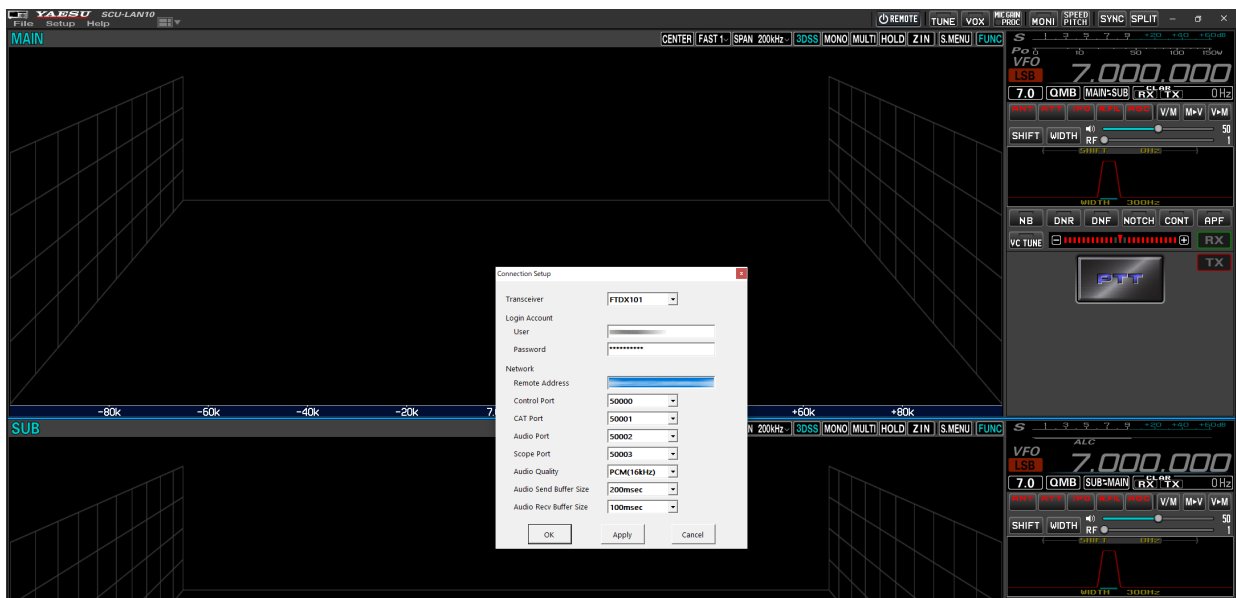

2. On the “**Connection Setup**” screen, configure the settings required to connect to SCU-LAN10.
 - This setting is required only once the first time.
 - You can always change it later with “**Connection Setup**” in the Setup menu.

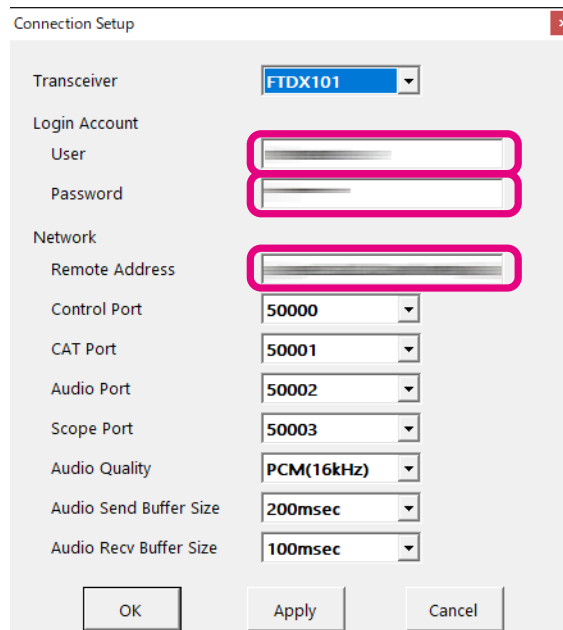

(1) Login Account settings

User: Enter the User that is set for SCU-LAN10.

Password: Enter the password that is set for SCU-LAN10.

(2) Network settings

Remote Address: Enter the remote address to connect to SCU-LAN10.

The settings differ depending on the network environment as follows:

When using the Internet

For fixed global IP: Enter the fixed IP address obtained from the provider

For dynamic DNS service: Enter the acquired domain name

When using a local LAN

Enter the IP address set for SCU-LAN10

Example: 198.168.0.100

Normally, other setting items do not need to be changed.

3. After completing the settings, click the **[OK]** button.

The connection settings are complete.

About setting items

Transceiver Select the transceiver to connect. Only “**FTDX101**” can be selected. (As of April 2020)

Login Account

User See above for details.

Password See above for details.

Network

Address See above for details.

Control Port PORT number used for remote control. It can be set in the range of 49990 to 50009. (Default setting: 50000) Normally, it does not need to be changed.



If you set another port number with the setting software in the initial setting, you need to set the same port number.

CAT Port PORT number used for remote control. It can be set in the range of 49990 to 50009. (Default setting: 50001) Normally, it does not need to be changed.

Audio Port PORT number used for remote control. It can be set in the range of 49990 to 50009. (Default setting: 50002) Normally, it does not need to be changed.

Scope Port PORT number used for remote control. It can be set in the range of 49990 to 50009. (Default setting: 50003) Normally, it is not need to be changed this.

Audio Quality Select the audio format sampling rate to use for transmission. (Default setting: PCM (16kHz)) Normally, there is no need to change this. Depending on the line status, changing the setting may stabilize the voice quality.
PCM(16kHz), PCM(8kHz), μ-Law(16kHz), μ-Law(8kHz)
μ-Law is a compressed format.

Audio Send Buffer Size Select the transmission buffer size of the audio transmitted from the transceiver. (Default setting: 200 (msec)) Normally, it is not necessary to change this. Depending on the line status, changing the setting may stabilize the voice quality.

Audio Recv Buffer Size Select the audio buffer size for the audio received by the transceiver. (Default setting: 100 (msec)) Normally, it is not necessary to change this. Depending on the line status, changing the setting may stabilize the voice quality

Initial audio level settings

Make the initial settings for levels of the transmitted audio and received audio.

Make settings on the Windows system and fine-tune on the screen of the remote control software during operation.

Windows volume control

1. Click **[Setup]**, and then click **[Audio Setup]**.

The “**Audio Setup**” screen will appear.

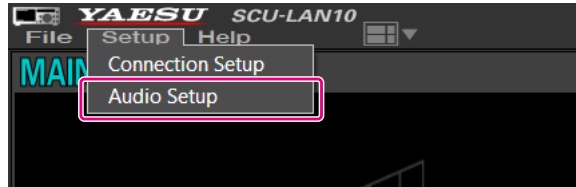

2. Click “**Open System Sound**”.

The Windows “**Sound**” screen appears.

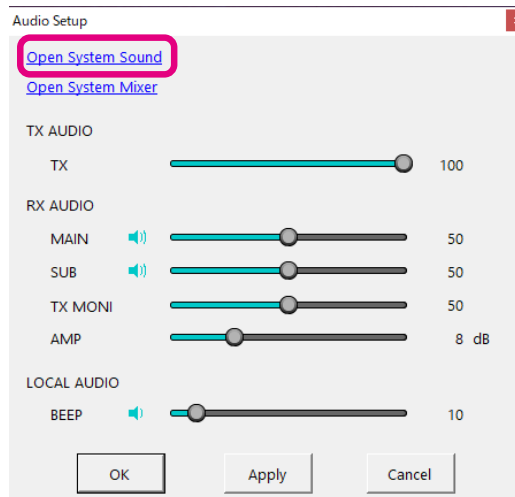

3. Click **[Speaker]** and then click **[Properties]**.

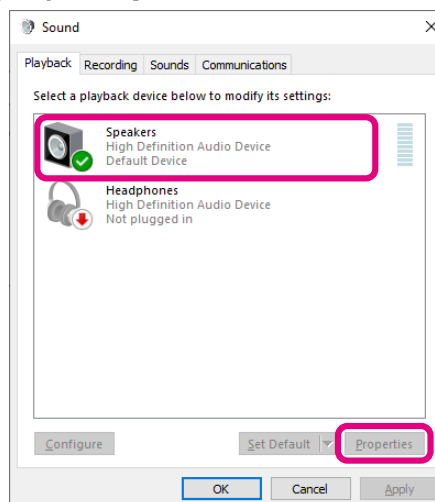

4. Click the [Level] tab.

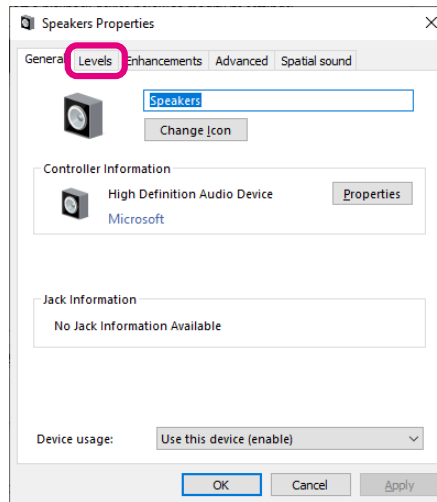

5. Drag the [Slide Bar] to adjust the volume and then click [OK].

✘ This volume level is the system master volume. You cannot hear the received sound if it is muted or is zero.

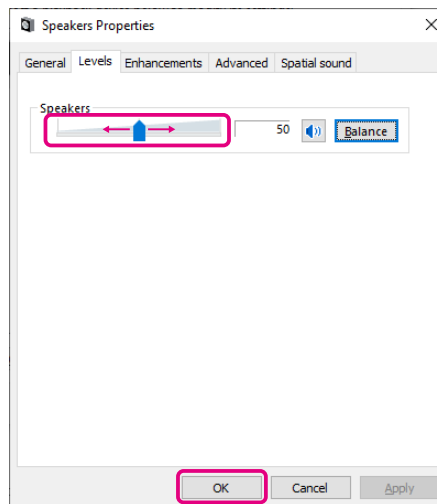

6. Click the [Recording] tab.

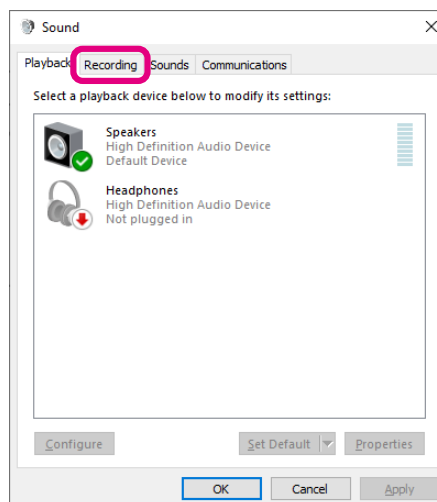

7. Click the [Recording device] that is connected to the microphone, and then click [Properties].
The “Properties” screen of the recording device is displayed.

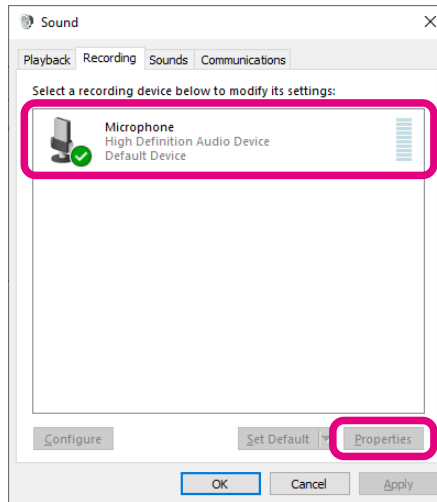

8. Click the [Level] tab.

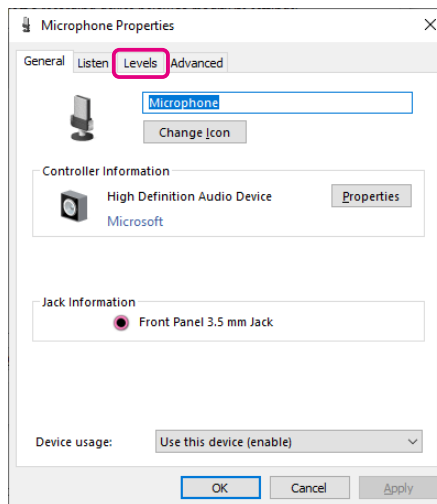

9. Drag the [Slide Bar] to adjust the microphone volume, then click [OK].
※ If it is muted (no sound) or set to zero, the transceiver cannot be modulated from the microphone of the computer.

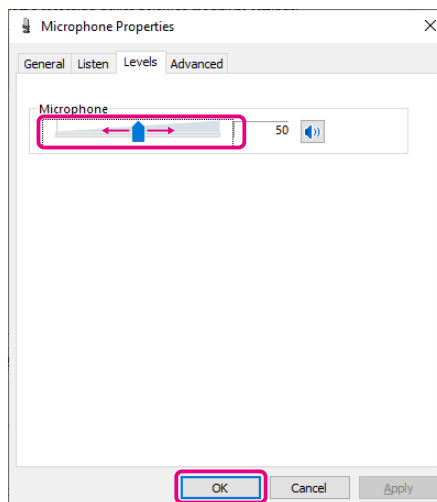

10. Click [OK] on the Windows “Sound” screen.

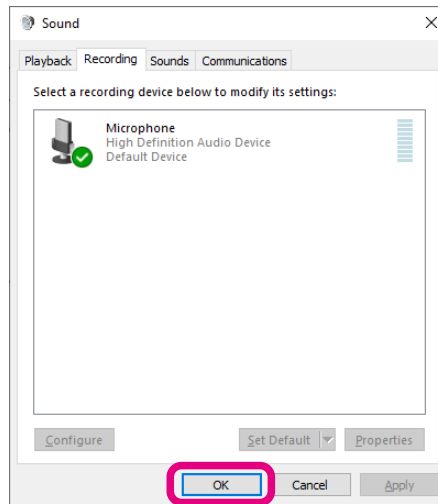

11. On the “Audio Setup” screen, click “Open System Mixer”.
The Windows “Volume Mixer” screen appears.

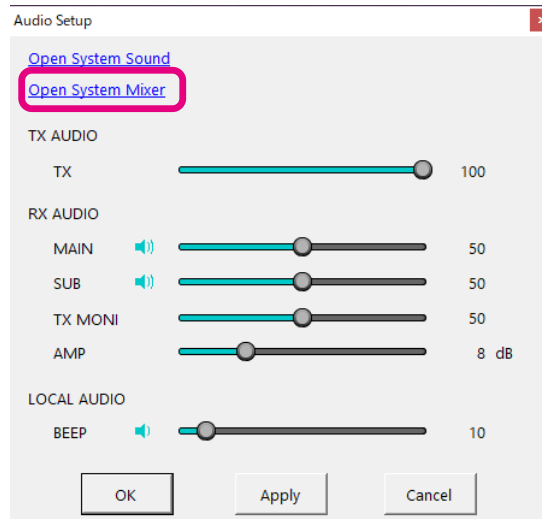

12. Drag the “SCN-LAN10 Remote Control Software” [slide bar] to adjust the speaker volume.

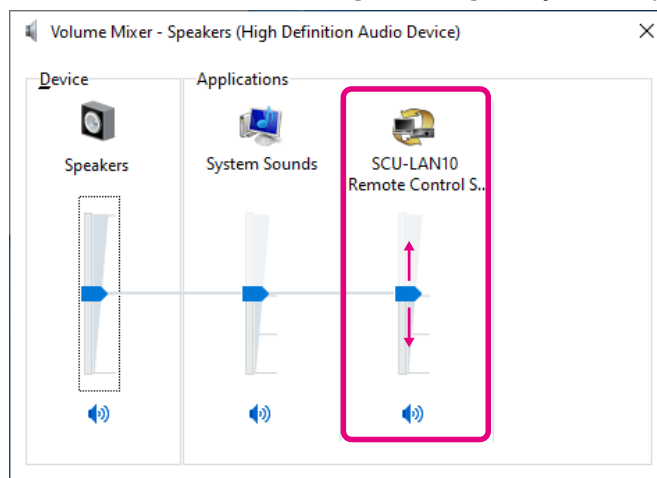

13. Click the [X] at the top right of the screen to close the screen.

Volume control of SCU-LAN10 Network Remote Control Software

1. Adjust the volume on the “**Audio Setup**” screen.

If the “**Audio Setup**” screen is not open, click [**Setup**] and then [**Audio Setup**].

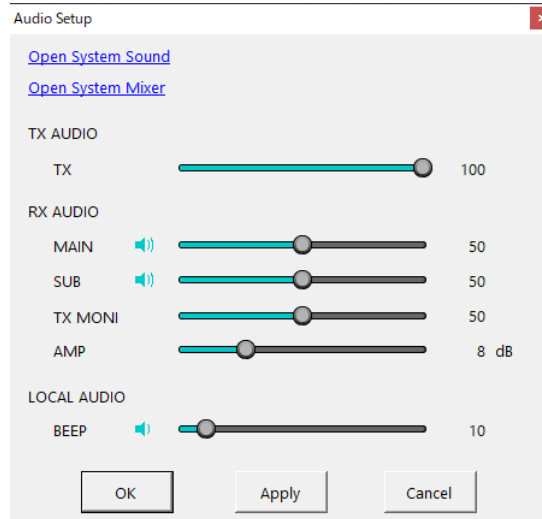

TX AUDIO

TX

Adjust the transmit modulation level.

This adjustment is the same as the MIC GAIN adjustment bar that appears when you right-click the MIC GAIN/PROC button.



RX AUDIO

MAIN

Adjusts the receive volume of the MAIN band.

This adjustment is the same as the volume control bar on the MAIN band operation block.



SUB

Adjusts the receive volume of the SUB band.

This adjustment is the same as the volume control bar on the SUB band operation block.



TX MONI

Adjusts the volume of the transmit audio that is monitored by the monitor function.

This adjustment is the same as the MONI adjustment bar that appears when you right-click the MONI button.



AMP

Adjust this when the receive sound of the MAIN and SUB band, or the TX MONI volume is extremely low or distorted even after the Windows volume adjustment or the above volume adjustment. Normally you do not need to change. (Factory setting: 8 dB)

LOCAL AUDIO

BEEP

Adjusts the beep volume when operating the remote control software.

※ If the volume is extremely low or distorted even after adjustment on the “**Audio Setup**” screen, perform the Windows volume adjustment again with “**Windows volume control**” (Page 35).

Start remote control

1. Press [REMOTE] button.

If “NETWORK ERROR” is displayed or remote control does not start, reconfirm “Install the Network Remote Control Software” (Page 11).

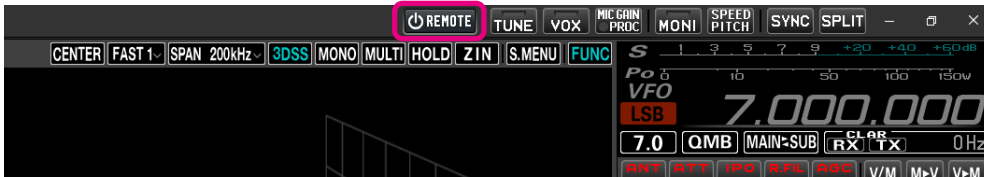

• Warning sign

If the warning sign illuminates or occasionally opens, there may be a problem with the network line or port open settings. Refer to the SCU-LAN10 Installation Manual and restart the settings from the beginning. Click the warning sign to see the detected issues.

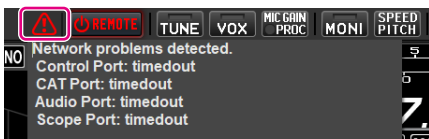

Refer to the Remote Control Unit SCU-LAN10 Operation Manual for details on remote control operation. The operation manual can be opened by clicking “Operation Manual (English)” from the Help menu of the remote control software. Or open the pdf file (SCU-LAN10_Operation_Manual_ENG.pdf) in the software folder.

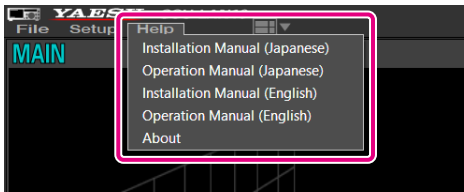

Installation Manual (English)
Operation Manual (English)

Open the PDF file (this document) of the installation manual (This manual).
Open the PDF file of the Operation manual (English).

● Exit remote control

1. Press [REMOTE] button again.



Copyright 2020
YAESU MUSEN CO., LTD.
All rights reserved.

No portion of this manual may be
reproduced without the permission of
YAESU MUSEN CO., LTD.

YAESU MUSEN CO., LTD.

Tennozu Parkside Building
2-5-8 Higashi-Shinagawa, Shinagawa-ku, Tokyo 140-0002 Japan

YAESU USA

6125 Phyllis Drive, Cypress, CA 90630, U.S.A.

YAESU UK

Unit 12, Sun Valley Business Park, Winnall Close
Winchester, Hampshire, SO23 0LB, U.K.