

POCKET-SCAN FM Monitor Receiver

Dual Band : 30—50 & 144—174 MHz

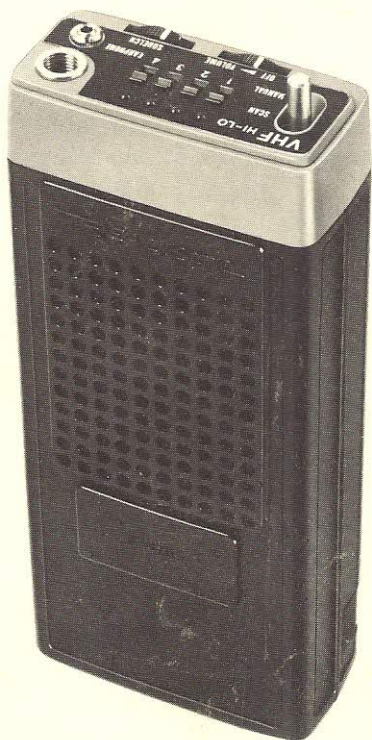

PRO-20

**OWNER'S
MANUAL**

PLEASE READ BEFORE
USING THIS EQUIPMENT

REALISTIC[®]

**CAT. NO.
20-101**

CUSTOM MANUFACTURED FOR RADIO SHACK



A DIVISION OF TANDY CORPORATION

Your Realistic Pocket Scan FM Monitor Receiver will let you follow the "action bands" wherever you go. The compact unit is capable of scanning any four frequencies in the VHF Hi and Lo bands. That means you can receive police, fire, civil defense, radio telephone, National Weather Service and many other public service channels. Just obtain the correct crystals for the channel(s) you wish to monitor and plug them in. (Your Radio Shack salesperson can help you determine which crystals to buy for your needs and interests.)

The PRO-20 has many special internal features you can't see from the outside—but they sure make a difference in the performance!

- Sensitive, dual-conversion superheterodyne circuit
- One crystal filter and one ceramic filter for superior selectivity
- Built-in scan delay to prevent missed callbacks
- Stable and dependable solid-state circuitry, including 2 ICs, 14 Silicon Transistors, 16 Diodes and 4 LEDs

And there are plenty of convenience features, too:

- Selectable automatic or manual scanning
- Individual channel lockout switches so you can skip over any channel(s) you're not interested in monitoring
- LED channel indicators
- Two screw-in antennas, one short for convenient use anywhere, the other longer for optimal reception
- Earphone and earphone jack for private listening
- Recharger jack for use with Nickel-Cadmium batteries
- External power jack so you can operate the Pocket Scan from an external source of 6-volt DC negative ground power

For your own protection, we urge you to record the Serial Number of this unit in the space provided. You'll find the Serial Number on the back of this unit.

Serial No.

839496

RADIO SHACK LIMITED WARRANTY

This equipment is warranted against defects for 1 year from date of purchase. Within this period, we will repair it without charge for parts and labor. Simply **bring your sales slip** as proof of purchase date to any Radio Shack store. Warranty does not cover transportation costs. Nor does it cover equipment subjected to misuse or accidental damage.

This Warranty gives you specific legal rights and you may also have other rights which vary from state to state.

We Service What We Sell

WARNING

The PRO-20 is designed to operate from four penlight (AA) batteries (connected in series), or an external source of +6 volts DC (**negative ground**). If it fails to operate, and there is no clear reason for the failure, first check the batteries. Before you try connecting the PRO-20 to an external 6-volt DC power supply, check the voltage polarity. **Attempting to operate the negative ground PRO-20 from a positive ground electrical system, may damage it.** The Radio Shack warranty does not apply to any damage caused by improper power connections or other damage caused by misuse, or neglect.

SPECIFICATIONS

CHANNELS OF OPERATION:	Four—as determined by any one of 4 crystals operating in the frequency range
FREQUENCY RANGE:	30 to 50 MHz and 144 to 174 MHz
FREQUENCY COVERAGE:	VHF Lo 6 MHz for maximum sensitivity (40 MHz \pm 3 MHz) VHF Hi 8 MHz for maximum sensitivity (153MHz \pm 4 MHz)
SENSITIVITY:	Better than $1\mu\text{V}$ for $(S+N)/N=20\text{dB}$
SELECTIVITY:	± 9 kHz, -6 dB ± 17 kHz, -50 dB
MODULATION ACCEPTANCE:	± 7 kHz
I.F.:	10.7 MHz and 455 kHz
FILTERS:	10.7 MHz Crystal Filter and 455 kHz Ceramic Filter
SQUELCH SENSITIVITY:	Variable from less than $1\mu\text{V}$
SCANNING SPEED:	6 channels/second
DELAY TIME:	1 to 3 seconds
AUDIO POWER:	150 mW
POWER REQUIREMENTS:	+6V DC (negative ground only) Current drain: 40 mA (Squelched) 100 mA (full volume, unsquelched)
SEMICONDUCTOR COMPLEMENT:	2 Integrated Circuits 14 Silicon Transistors 16 Diodes 4 Light Emitting Diodes (LED's)
SPEAKER:	2" (5cm), 16 ohm, Permanent Magnet, dynamic type
ANTENNAS:	Telescopic and flexible types 24-3/4" (63cm) 7-3/4" (19.5cm)
CRYSTAL REQUIREMENTS:	Standard HC-25/u 3rd overtone

PREPARATION FOR USE

To use your POCKET-SCAN, you must do three things:

- Install the batteries
- Connect one of the antennas supplied
- Install 1, 2, 3 or 4 crystals

To install the batteries, turn the receiver face down, press in firmly on both sides of the section marked BATTERY PACK, and lift the compartment up and away.

Remove the battery pack. Insert four AA batteries, one at a time, making sure the polarity markings inside the battery pack match up (+ to + and - to -) with markings on the batteries.

We recommend that you use rechargeable Nickel Cadmium AA batteries, Radio Shack Catalog Number 23-125, or AA Alkaline ENERGCELLS, Catalog Number 23-552.

Press the Battery Pack into place (press sides of Battery Pack inward to snap it back into the case).

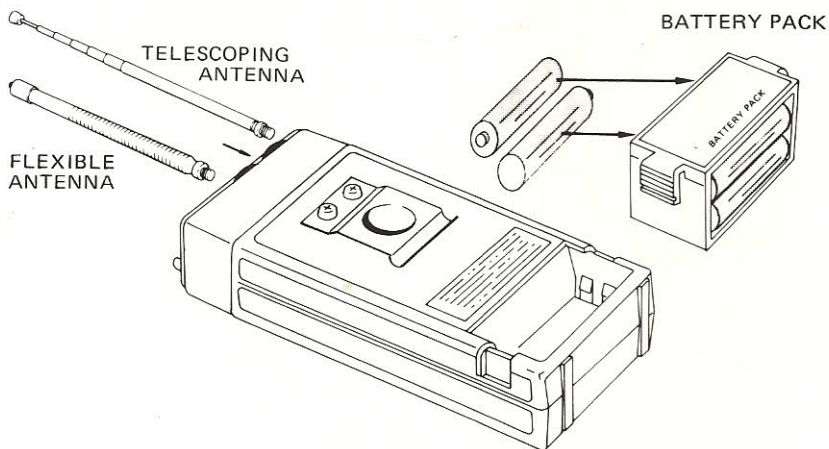

Two antennas are provided with the PRO-20: a flexible "rubber duck" antenna and a telescoping one. The flexible antenna is for use in cramped areas or wherever a longer antenna would get in the way. The telescoping antenna is for obtaining the very best possible reception from your receiver. The telescoping antenna must be extended fully for proper operation.

Crystals are not included with your POCKET-SCAN because the frequencies are so numerous. The frequencies used in your part of the country will be different from those used in other areas. Your Radio Shack Store Manager will advise you as to what frequencies are most used and help you in your selection of crystals.

Remove the Crystal Compartment Cover by sliding it to the left and insert crystal(s) into the crystal socket (Lo or Hi). Provision is made to install 4 crystals; each position can be used for either VHF Hi or VHF Lo. Follow the illustration provided for proper installation of each crystal.

For VHF Lo crystals, use the center and lower crystal socket holes.

For VHF Hi crystals, use the center and upper crystal socket holes.

In the example shown, Channel 1 will have a VHF Lo crystal and Channel 4 will have a VHF Hi crystal.

CRYSTAL COMPARTMENT COVER

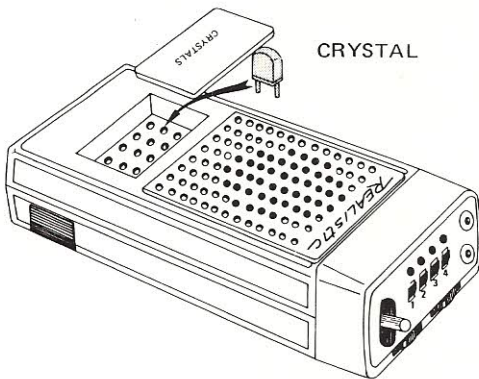

CRYSTAL SOCKETS

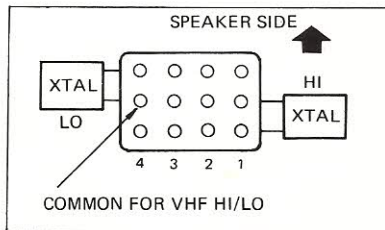

Since crystal frequencies must be extremely accurate and crystals should be matched for specific units, we recommended you obtain crystals for your POCKET-SCAN only from Radio Shack. Be sure to specify the Catalog Number and Model description of your Monitor Receiver. We can not be responsible for the poor or improper operation of crystals from any other manufacturer.

CONTROL LOCATION AND FUNCTION

OFF-VOLUME is the power switch and volume control. When not in use, rotate this control to the left to turn it off.

SQUELCH control is to eliminate annoying background noise between signal transmissions. When properly set, SQUELCH will keep the PRO-20 silent until a signal comes in on the channel(s) you are listening to—then, the Squelch circuit will “open” and you’ll hear the signal.

SCAN/MANUAL Switch determines the function of the scanning feature. In SCAN position, each channel will be scanned automatically. In the center (stop) position, the PRO-20 will not scan, but will remain tuned to the channel indicated by the LED. To advance the receiver to the next channel in sequence, press to the MANUAL position momentarily; each time you do so, the receiver will advance one channel.

Channel Lock-Out Switches—let you activate the four channels individually. When a switch is up (next to LED), that channel will be scanned for messages in either automatic or manual mode; when switch is down, that channel will be skipped (“locked out”) by the scanner. When a channel is vacant (no crystal plugged in) or when you don’t want to monitor that channel, leave its switch down. Otherwise leave the switches in the “up” position.

LED Channel Indicators—show which channel is currently being scanned or monitored. Each channel indicator will light up for an instant as it is scanned; if there is a message on that channel, the LED will remain lit until message is over and scanning resumes. Locked-out channels will not be scanned; therefore their indicators will not light up.

EARPHONE jack is for plugging in the earphone. Use it for private listening or in areas where background noise is excessive (in factories, at the scene of an accident or fire, in a vehicle, etc.). Plugging in the Earphone disconnects the PRO-20’s internal speaker.

Antenna jack is for connecting an antenna to the PRO-20. You can use either the telescopic antenna or flexible antenna provided.

A Belt Clip is provided so you can attach the PRO-20 to your belt or other convenient place.

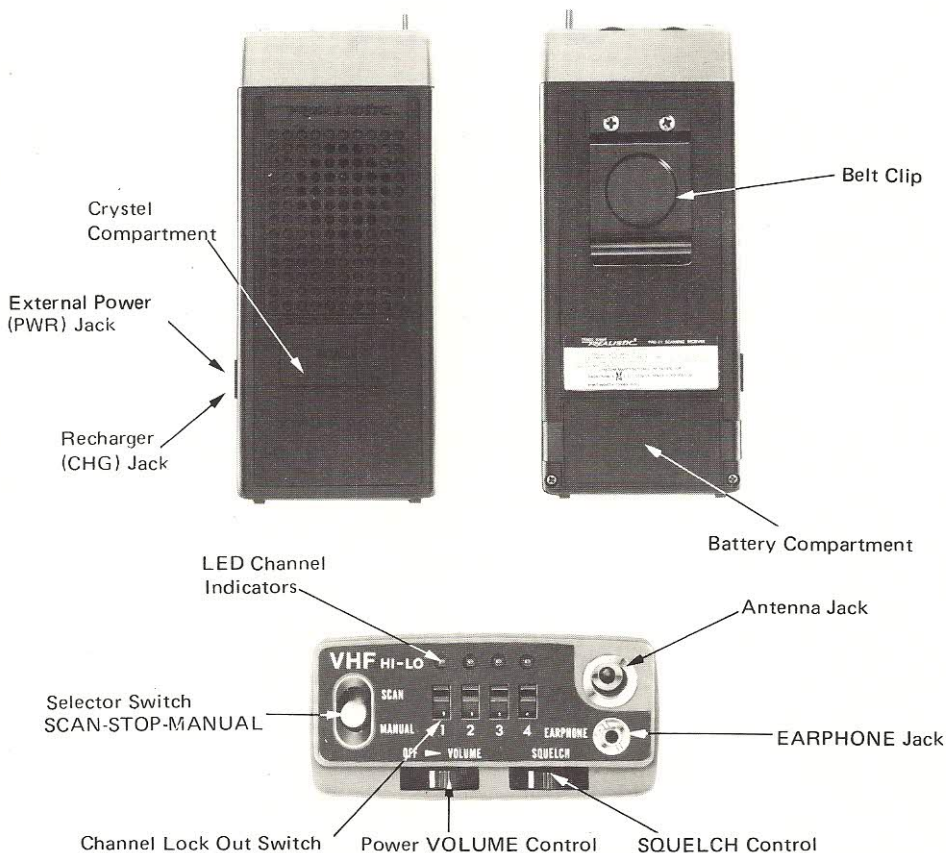

Battery Compartment holds the internal power source (4 type AA batteries).

Crystal Compartment contains crystals selected for operation.

External PoWeR Jack lets you connect an external source of 6 volts DC (negative ground) for operation without batteries.

To recharge Nickel Cadmium batteries in the receiver, simply plug an external 6 volt DC power source into the **CHG JACK**. To fully charge Ni-Cads, leave them on charge for 10–18 hours.

NOTE

The **Recharge (CHG) jack** is to be used only when Nickel Cadmium batteries are installed in the receiver. Also, do not attempt to operate the unit while recharging Ni-Cads.

OPERATION

After batteries, crystal(s) and antenna (telescopic or flexible) have been installed, your PRO-20 is ready to use.

Turn Power "on" by rotating **VOLUME** to the right. Rotate **SQUELCH** to the minimum position by rotating to the left. Set all the **Channel Lock-out Switches** "on" (in the up position, toward the LED indicators). You should hear a rushing sound from the speaker. Rotate **SQUELCH** toward the right until the background noise abruptly stops. You can't adjust **SQUELCH** properly while listening to a station, so wait until signals cease. If you set **SQUELCH** correctly, the PRO-20 will appear "dead" until a signal comes in; when a signal comes in, the Squelch circuit will "open up" and you'll hear the signal. When the signal ceases, the Squelch circuit will "close" and cut out all sound until the next signal comes in.

If you want the PRO-20 to continuously scan the channels for which you have crystals installed, you must adjust **SQUELCH** as previously instructed, then set the **Selector Switch** to the SCAN position. The PRO-20 will constantly scan each channel in sequence; when a signal appears on one of the channels the receiver will lock onto that channel and you will hear the signal.

If you do not want automatic scanning on one or more channels, switch their **Channel Lock-out Switches** to the "off" position (down or away from the LED indicator).

If you want to stay tuned to one channel only, set the **Selector Switch** to the center position (stop scanning) and then press to the **MANUAL** position momentarily to advance to the channel you want to listen to (as indicated by the LED above that channel switch). For **MANUAL** scanning, the receiver can be either "squelched" (adjusted as previously indicated) or "unsquelched" (**SQUELCH** control set to extreme left). For **AUTOMATIC** scanning, **SQUELCH** must be set to eliminate the background noise.

MAXIMUM SENSITIVITY RANGE

This Receiver will function very adequately down to 30 and up to 50 and from 144 to 174 MHz, but with reduced sensitivity at the upper and lower extremes. For maximum sensitivity on the VHF-Lo band, the channel frequencies you choose should be within 3 MHz of 40 MHz (that is, in the spread of 37 to 43 MHz). For the VHF-Hi band, stay within 4 MHz of 153 MHz (that is, 149 to 157 MHz). The superior reception spread of 6 or 8 MHz ($\pm 3/4$ MHz) can be moved up or down in either band of frequencies by special realignment of the front end circuitry of this Receiver (which should be attempted only be qualified Electronics Service Technicians who have adequately calibrated, precision test equipment).

With such realignment, your Receiver can tune signals in the Ham bands and other services. We call your attention to the fact that this Receiver is designed for reception of FM signals and thus can not be used for monitoring AM signals (even though they may be within the frequency coverage range). These AM signals include much of the aircraft services.

TYPES OF SIGNALS YOU'LL BE ABLE TO MONITOR

Your community is alive with action—action which is constantly being reported on the airwaves. And your PRO-20 will automatically scan the airwaves to bring you that action—your police force at work, a fire truck on a mission, Ham Radio operators, highway and other emergency-type services, some industrial services, some transportation services (taxi, trucks, railroad), plus some Government services. Lots of things are going on that most of us just are never aware of. But, with the right frequency crystals in your PRO-20 you can monitor such exciting signals. You'll have to do a little investigating in your community to find out what services are active and on what frequencies. You will find one of our books to be very interesting and helpful in this area: *REALISTIC GUIDE TO POLICE, FIRE AND AIRCRAFT RADIO*.

What to listen for and where? That is a little difficult for a specific answer. Each area of the country can and will use different frequencies. All we can do is give you some general pointers and let you take it from there.

Find out if there is a local club which monitors these frequencies. Often a local electronics repair shop that does work on the equipment can give you the channel frequencies used by local radio services. A volunteer police or fire employee can also be a good source of this information.

An interesting service is the Mobile Telephone. FCC has assigned this service channels in the range of 152.51 to 152.81 MHz at every 0.030 MHz (channels are 30 kHz apart).

As a general rule on VHF, most activity will be concentrated between 153.785 and 155.98 and then again from 158.73 to 159.46 MHz. Here you'll find local government, police, fire and most such emergency services. If you are near a railroad yard or major railroad tracks, look around 160.0 to 161.9 MHz for them.

If you live near the coast or the Great Lakes, another interesting service is Marine Radiotelephone (operates in the frequency range of 156 to 158 MHz).

Some of the more interesting frequencies are:

156.8 MHz for calling and distress safety

156.3 MHz for intership safety, plus search and rescue

157.1 MHz U.S. Coast Guard Liaison

156.425 MHz non-commercial ship-to-ship/ship-to-coast/coast-to-ship

Other frequencies may be of special interest; check with local Coast Guard offices.

NATIONAL WEATHER SERVICE RECEPTION

Continuous weather broadcasts are transmitted 24 hours a day in many parts of the country. If you are using a crystal set to one of the three channels assigned (162.55, 162.40 or 162.475 MHz), your PRO-20 will automatically lock-in on that channel, since the broadcasts are continuous. To prevent automatic locking, set the channel lock-out switch for that channel to the "off" position (down). When you want a weather report, set the Lock-Out Button to the "on" position (up) for that channel. Check with your local FCC office or the Weather Bureau to find out which of the three frequencies (162.40, 162.55, or 162.475 MHz) is used in your area.

ACCESSORIES

Your PRO-20 can be powered from any source of 6 volts DC, negative ground, by connecting the external power source to the PWR jack. Using an AC adapter will save on batteries; so, if you intend to use the PRO-20 in a location where 120 volts is readily available, and it does not need to be moved around, consider an adapter. Radio Shack has two power adapters which you might be interested in. Catalog Number 20-189 is an adapter for 120 volts AC, specifically designed for Radio Shack's Pocket Scanners. It provides 6 volts DC and can be used either as a Charger or an AC Adapter.

Catalog Number 270-1561 is a power adapter for plugging into a cigarette lighter socket in your vehicle and providing either 6 or 9 volts DC (positive or negative—set for tip positive). This will permit you to use the PRO-20 in your car or truck without wearing down your batteries. This adapter can also be used with either CHG jack (to recharge Ni-Cads) or with the PWR jack.

MAINTENANCE

The PRO-20 is a ruggedly built electronic unit, with all parts conservatively rated. However, you should treat it with care; don't subject it to excessively rough handling. You will find it will give you long life if kept free from dirt and excessive humidity.

If the sound becomes weak and distorted, it is time for new batteries. We recommend Radio Shack Alkaline batteries, Catalog Number 23-552. Or, use our ENERCELL rechargeable batteries (23-125)—you can recharge them hundreds of times. You can charge them while in the unit; just connect 20-189 to the CHG jack. Or, you can charge them out of the unit by using our 270-1501. If you do not intend to use the PRO-20 for a few weeks, it is best to remove the batteries. Also, never leave weak or dead batteries in the unit.

BLOCK DIAGRAM

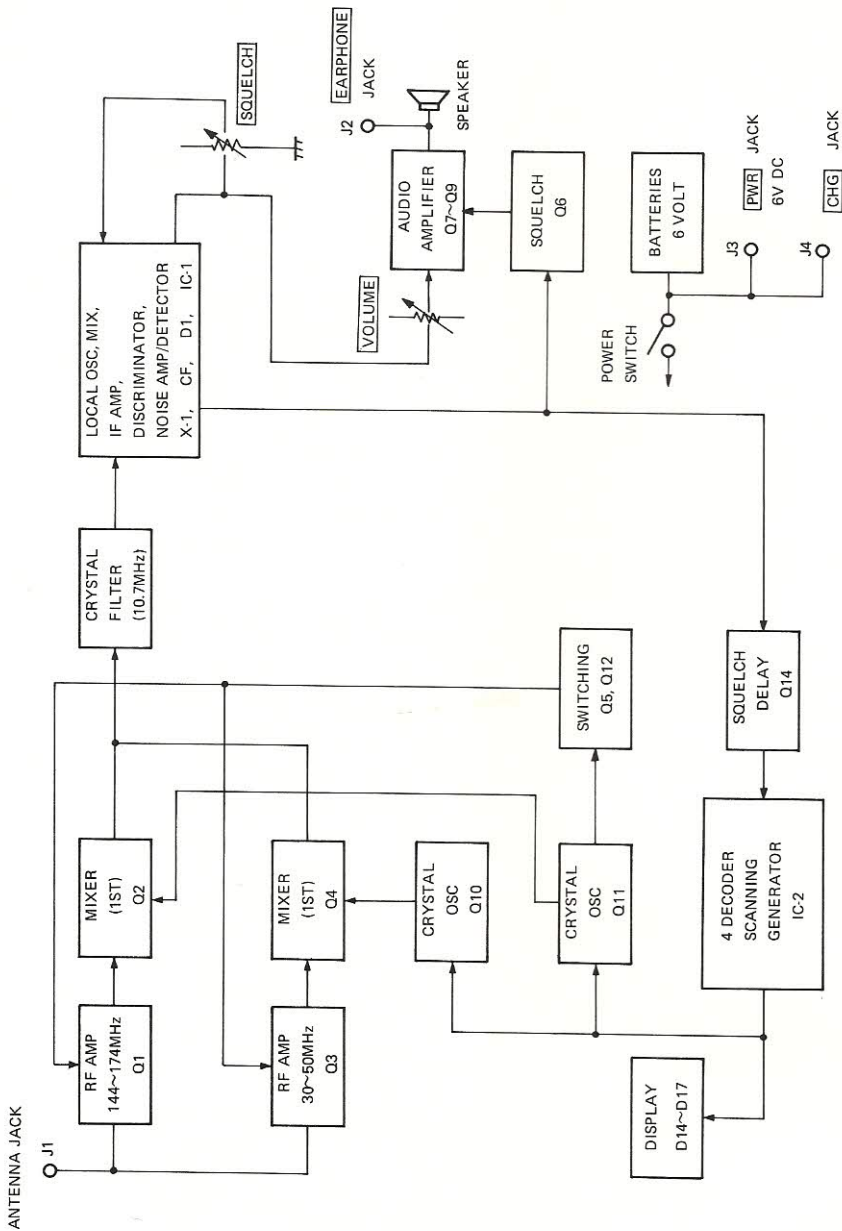

SCHEMATIC DIAGRAM

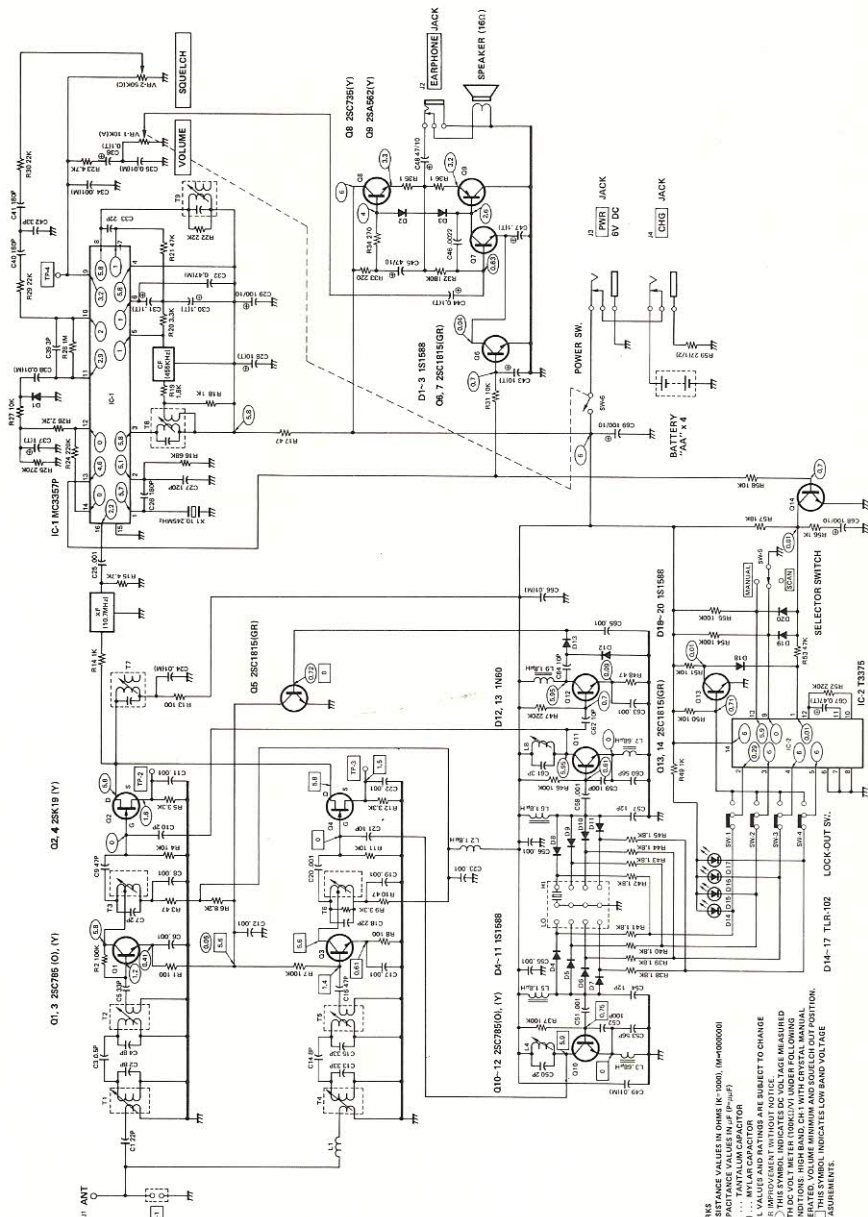

- REMARKS:
1. RESISTANCE VALUES IN OHMS (Ω), 1000 (K)=1000000
 2. CAPACITANCE VALUES IN μF (P=picofarad)
 3. MV=millivolt
 4. SW SWITCH
 5. ALL VALUES AND RATIOS ARE SUBJECT TO CHANGE
 6. THIS SYMBOL INDICATES DC VOLTAGE MEASURING POINTS
 7. THIS SYMBOL INDICATES LOW BAND VOLTAGE MEASUREMENT.

RADIO SHACK  **A DIVISION OF TANDY CORPORATION**
U.S.A.: FORT WORTH, TEXAS 76102
CANADA: BARRIE, ONTARIO L4M 4W5

TANDY CORPORATION

AUSTRALIA	BELGIUM	U. K.
280-316 VICTORIA ROAD RYDALMERE, N.S.W. 2116	PARC INDUSTRIEL DE NANINNE 5140 NANINNE	BILSTON ROAD WEDNESBURY, WEST MIDLANDS WS10 7JN