

handic

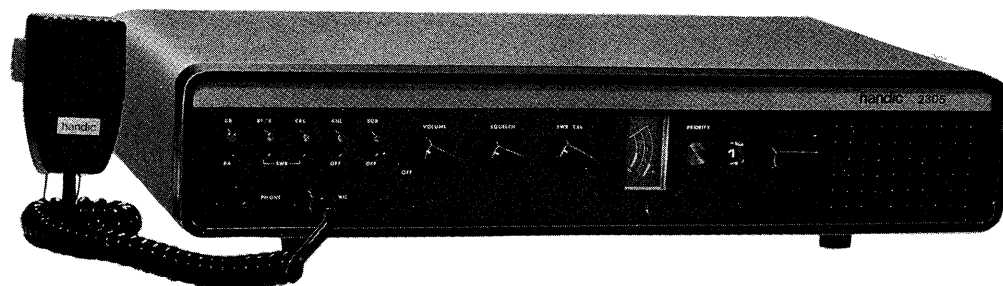

**SERVICE MANUAL
FOR
handic 2305
CITIZEN'S BAND
23 CHANNELS PLUS ONE
5 WATTS BASE STATION
TRANSCEIVER**



handic
bolagen



Telex 2558 Telephone 031-45 01 80
Box 156 S-42122 V. Frölunda, Sweden

CONTENTS

	Page
1. SPECIFICATIONS	3
2. DISASSEMBLY AND SUBRECEIVER CRYSTAL INSTRUCTIONS	4
3. SELECTIVE CALL	4
4. GENERAL ALIGNMENT INSTRUCTIONS	4
5. ALIGNMENT POSITIONS	5
6. TRANSMITTER ALIGNMENT	6
7. AUTOMATIC MODULATION CONTROL ADJUSTMENT	6
8. RF POWER METER ADJUSTMENT	6
9. MAIN RECEIVER SECTION	
IF SECTION ALIGNMENT	6
RECEIVER ALIGNMENT	7
SQUELCH SENSITIVITY ADJUSTMENT	7
S-METER SENSITIVITY ADJUSTMENT	7
10. SUB RECEIVER SECTION	
RECEIVER ALIGNMENT	7
SQUELCH TIGHT SENSITIVITY ADJUSTMENT	7
11. MAIN AND SUB RECEIVER LEVEL SETTING	8
12. CRYSTAL OSCILLATOR FREQUENCY CHECK	8
13. REGULATED DC POWER SUPPLY ADJUSTMENT	8
14. BLOCK DIAGRAM	9
15. RF P.C.B. PARTS LOCATION TOP VIEW	10
16. RF P.C.B. PARTS LOCATION BOTTOM VIEW	11
17. AF/POWER SUPPLY P.C.B. PARTS LOCATION TOP VIEW	12
18. AF/POWER SUPPLY P.C.B. PARTS LOCATION BOTTOM VIEW	13
19. S.W.R. P.C.B. PARTS LOCATION TOP VIEW	14
20. S.W.R. P.C.B. PARTS LOCATION BOTTOM VIEW	14
21. BUFFER AMP P.C.B. PARTS LOCATION TOP VIEW	14
22. BUFFER AMP P.C.B. PARTS LOCATION BOTTOM VIEW	14
23. WIRING DIAGRAM	15
24. TROUBLE SHOOTING	16
25. RF P.C.B. PARTS LIST	17 ~ 22
26. AF/POWER SUPPLY P.C.B. PARTS LIST	23 ~ 25
27. S.W.R. P.C.B. PARTS LIST	25
28. BUFFER AMP P.C.B. PARTS LIST	25
29. CHASSIS ASSEMBLY PARTS LIST	26 ~ 27
30. TRANSISTOR LEAD IDENTIFICATIONS	27
31. SCHEMATIC DIAGRAM	28, 29
32. CHASSIS DISASSEMBLY DIAGRAM	30, 31

SPECIFICATIONS

Description	Nominal spec.	Limit spec.
TRANSMITTER SECTION		
Frequency range	26.965 – 27.255 MHz	Adjustable to 31 MHz
Frequency tolerance	±0.003%	±0.005%
DC power input	5 watts	
RF power output	3.5 watts	2.8 watts
Modulation	AM 90 ~ 100%	100%
Antenna impedance	50Ω	
MAIN RECEIVER SECTION		
Frequency range	26.965 ~ 27.255 MHz	Adjustable to 31 MHz
Sensitivity	0.5μV for 10 dB (S+N)/N	1μV for 10 dB (S+N)/N
Selectivity	100 dB at ±10 kHz	60 dB at ±10 kHz
I.F. 1st	10.595 to 10.635 MHz	
2nd	455 kHz	
Signal to noise ratio	45 dB at 1mV RF input	40 dB at 1mV RF input
Squelch sensitivity		
Threshold	0.5μV	1μV
Tight	500μV	50μV to 3mV
Audio output (10% distortion)	3.5 watts	3 watts
SUB RECEIVER SECTION		
Frequency range	26.965 ~ 27.255 MHz	Adjustable to 31 MHz
Sensitivity	0.7μV for 10 dB (S+N)/N	1μV for 10 dB (S+N)/N
Selectivity	45 dB at ±10 kHz	40 dB at ±10 kHz
I.F.	255 kHz	
Signal to noise ratio	45 dB at 1mV RF input	40 dB at 1mV RF input
Squelch sensitivity		
Threshold	0.7μV	1μV
Tight	500μV	50μV to 3mV
Audio output (10% distortion)	3.5 watts	3 watts
Semiconductors	38 Transistors, 25 Diodes (26 Diodes for U.S.A. Model only), 2 Rectifiers, 4 Thermistors and 1 Integrated circuit	
Channels	23 channels (transmitter and Main receiver)	
	1 channel (Sub receiver)	
Frequency control	Crystal control	

DISASSEMBLY AND SUBRECEIVER CRYSTAL INSTRUCTIONS

1. Remove the power plug from outlet.
2. Remove the 6 screws from back of the metal cabinet.
3. Push out the chassis.
4. Plug the subreceiver crystal into CRYSTAL SOCKET.

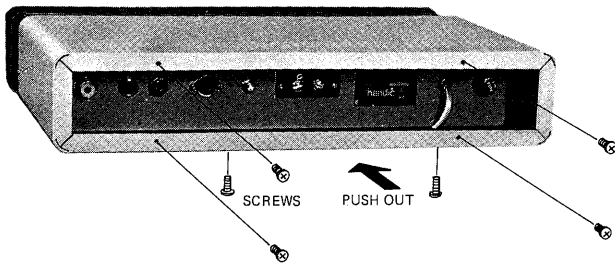

FIGURE 1

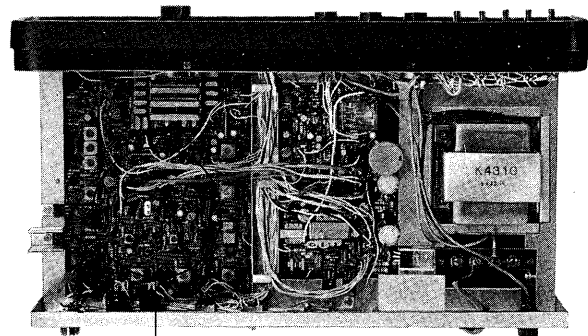

FIGURE 2

SELECTIVE CALL

Selective call 6P DIN jack is provided on the back of cabinet.
This jack is matched for **handic** S-10 and S-12 selective call units.

GENERAL ALIGNMENT INSTRUCTIONS

Test equipment required

1. RF standard signal generator (S.S.G.)
2. AF signal generator
3. V.T.V.M.
4. RF power meter
5. Oscilloscope
6. Monitor receiver
7. Frequency counter
8. 8 Ω dummy load
9. 50 Ω dummy load
10. 15 Ω dummy load

ALIGNMENT POSITIONS

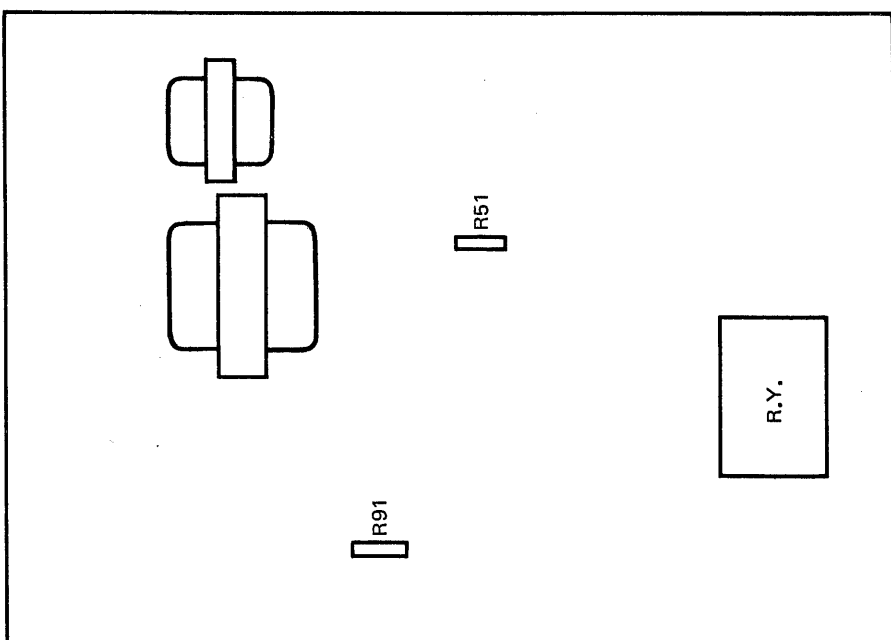
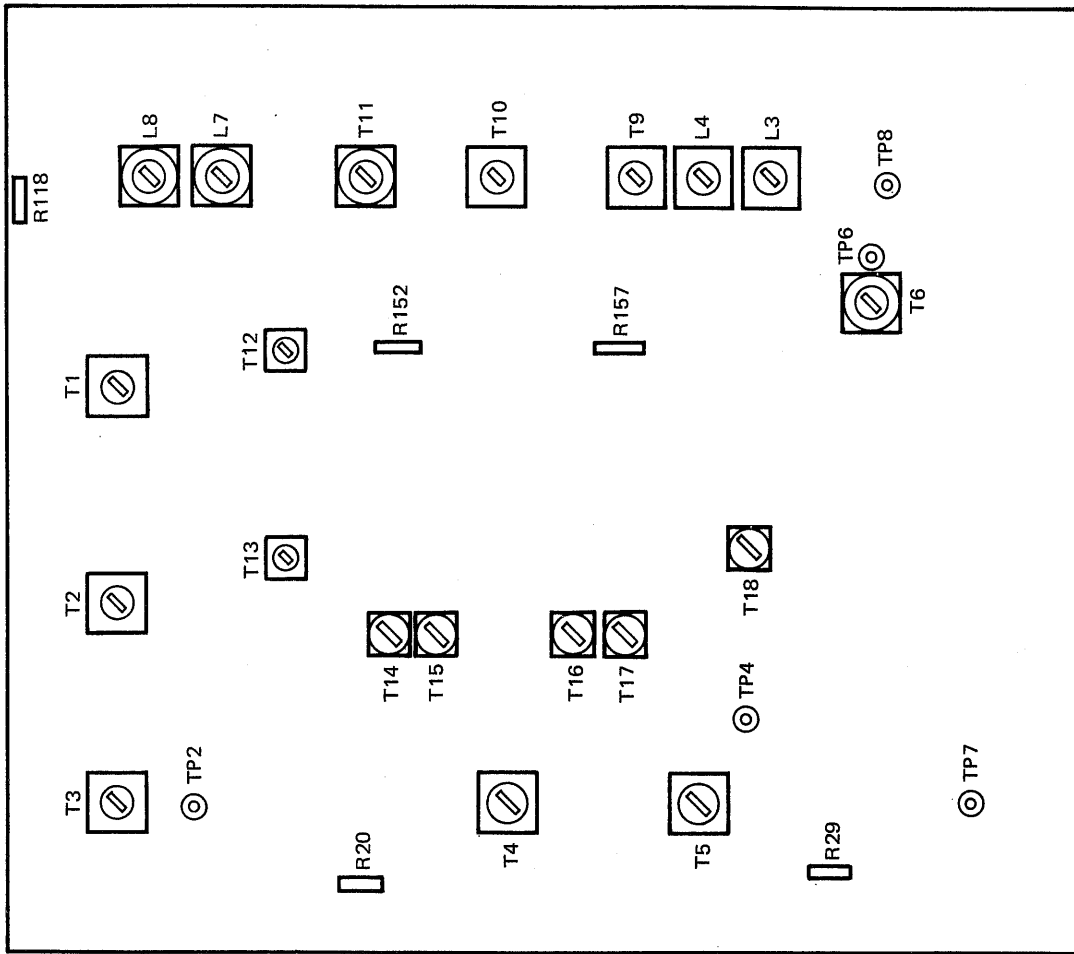

FRONT SIDE

FIGURE 3

TRANSMITTER ALIGNMENT

- Step 1: Connect the instrument as shown in Figure 4.
- Step 2: Set the channel selector to CH 13.
- Step 3: Adjust L3, L4, L7, L8, T6, T9, T10 and T11 to maximum reading on the power meter.
- Step 4: Check the power output CH 1 thru 23

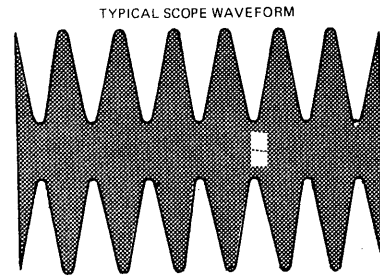
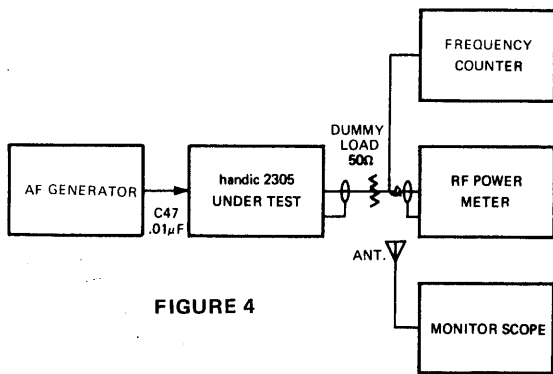

FIGURE 5

AUTOMATIC MODULATION CONTROL ADJUSTMENT

- Step 1: Connect an AF generator to pin 2 of J1 microphone jack.
- Step 2: Set the frequency of the AF generator to 2.5 kHz. Adjust the output for 50% modulation and after this increase the AF generator output 20 dB.
- Step 3: Adjust R51 semifixed resistor for 90 ~ 100% modulation.

RF POWER METER ADJUSTMENT

- Step 1: Connect the instrument as shown in Figure 4.
- Step 2: Set the channel selector to CH13.
- Step 3: Adjust R118 semifixed resistor to same reading on **handic 2305** meter as test power meter indication.

MAIN RECEIVER SECTION

IF SECTION ALIGNMENT

- Step 1: Connect the instruments as shown in Figure 6.
- Step 2: Set the channel selector to vacant channel. CH22 ~ 23 or CH22 ~ 11A (marked ● on the dial)
- Step 3: Adjust T4 and T5 for peak waveform.

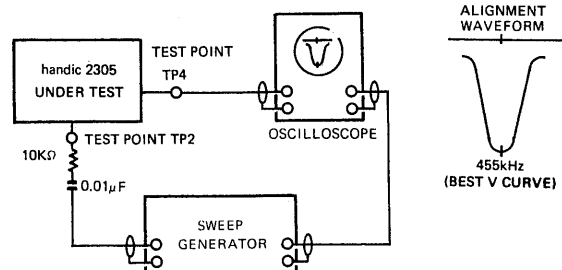

FIGURE 6

RECEIVER ALIGNMENT

- Step 1: Connect the instruments as shown in Figure 7.
- Step 2: Turn the VOLUME control full clockwise and SQUELCH control full counter-clockwise.
- Step 3: Adjust T1 for the best S/N point, T2 and T3 for the best sensitivity.

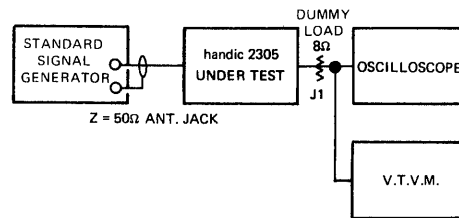

FIGURE 7

SQUELCH SENSITIVITY ADJUSTMENT

- Step 1: Connect the instruments as shown in Figure 7.
- Step 2: Set the channel selector to CH13 and SQUELCH control to maximum clockwise.
- Step 3: Set the signal generator output to $500\mu\text{V}$.
- Step 4: Set R20 semifixed resistor to open squelch point.

S-METER SENSITIVITY ADJUSTMENT

- Step 1: Connect the instruments as shown in Figure 7.
- Step 2: Set the channel selector to CH13.
- Step 3: Set the signal generator output to $100\mu\text{V}$.
- Step 4: Set R29 semifixed resistor for S9 reading on the S-meter.

SUBRECEIVER SECTION

RECEIVER ALIGNMENT

- Step 1: Insert a crystal into the socket.
- Step 2: Connect the instruments as shown in Figure 7.
- Step 3: Adjust T12, T13, T14, T15, T16, T17 and T18 for best sensitivity.

Note: Crystal frequency calculation.
The crystal frequencies are obtained by the following formula:
Frequency (MHz) = Receive frequency - 0.255

SQUELCH TIGHT SENSITIVITY ADJUSTMENT

- Step 1: Insert a crystal into the socket.
- Step 2: Connect the instruments as shown in Figure 7.
- Step 3: Turn the SQUELCH control on the back side full clockwise.
- Step 4: Set the signal generator output to $500\mu\text{V}$.
- Step 5: Set R152 semifixed resistor to open squelch point.

MAIN AND SUB RECEIVER LEVEL SETTING

- Step 1: Insert a SUB receiver crystal into the socket.
- Step 2: Connect the instruments as shown in Figure 7.
- Step 3: Set the signal generator output to $1\mu V$.
- Step 4: Receive the signal from MAIN receiver and set the VOLUME control for 1 Volt reading on the VTVM.
- Step 5: Receive the signal from SUB receiver and set the R157 for 1 Volt reading on the VTVM.

REGULATED DC POWER SUPPLY ADJUSTMENT

- Step 1: Connect a 15Ω 20W dummy load paralleled with DC VTVM between the emitter of Q22 2SC789 and ground.
- Step 2: Adjust R91 for 13.8 Volt reading on the DC VTVM.

CRYSTAL OSCILLATOR FREQUENCY CHECK

- Step 1: Connect the frequency counter as shown in Figure 3 and table 1.
- Step 2: Check if those crystals are oscillating.

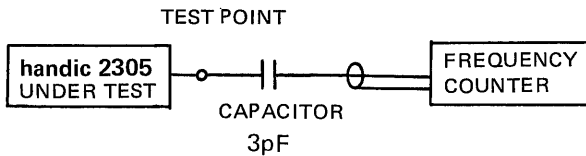

FIGURE 8

	TEST POINT
MASTER OSC	TP6
2ND OSC	TP7
TRANSMIT OSC	TP8

TABLE 1

Item Channel	Receiving or Transmitting Frequency	Test point TP-6 Master Osc.	Test point TP-8 Transmit Osc.	Testpoint TP-7 RX 2nd Osc.
1	26.965 MHz	37.600 MHz	10.635 MHz	10.180 MHz
2	26.975	"	10.625	10.170
3	26.985	"	10.615	10.160
4	26.005	"	10.595	10.140
5	27.015	37.650	10.635	10.180
6	27.025	"	10.625	10.170
7	27.035	"	10.615	10.160
8	27.055	"	10.595	10.140
9	27.065	37.700	10.635	10.180
10	27.075	"	10.625	10.170
11	27.085	"	10.615	10.160
12	27.105	"	10.595	10.140
13	27.115	37.750	10.635	10.180
14	27.125	"	10.625	10.170
15	27.135	"	10.615	10.160
16	27.155	"	10.595	10.140
17	27.165	37.800	10.635	10.180
18	27.175	"	10.625	10.170
19	27.185	"	10.615	10.160
20	27.205	"	10.595	10.140
21	27.215	37.850	10.635	10.180
22	27.225	"	10.625	10.170
23	27.255	"	10.595	10.160
11A	27.095	37.690	10.595	10.140

TABLE 2

BLOCK DIAGRAM

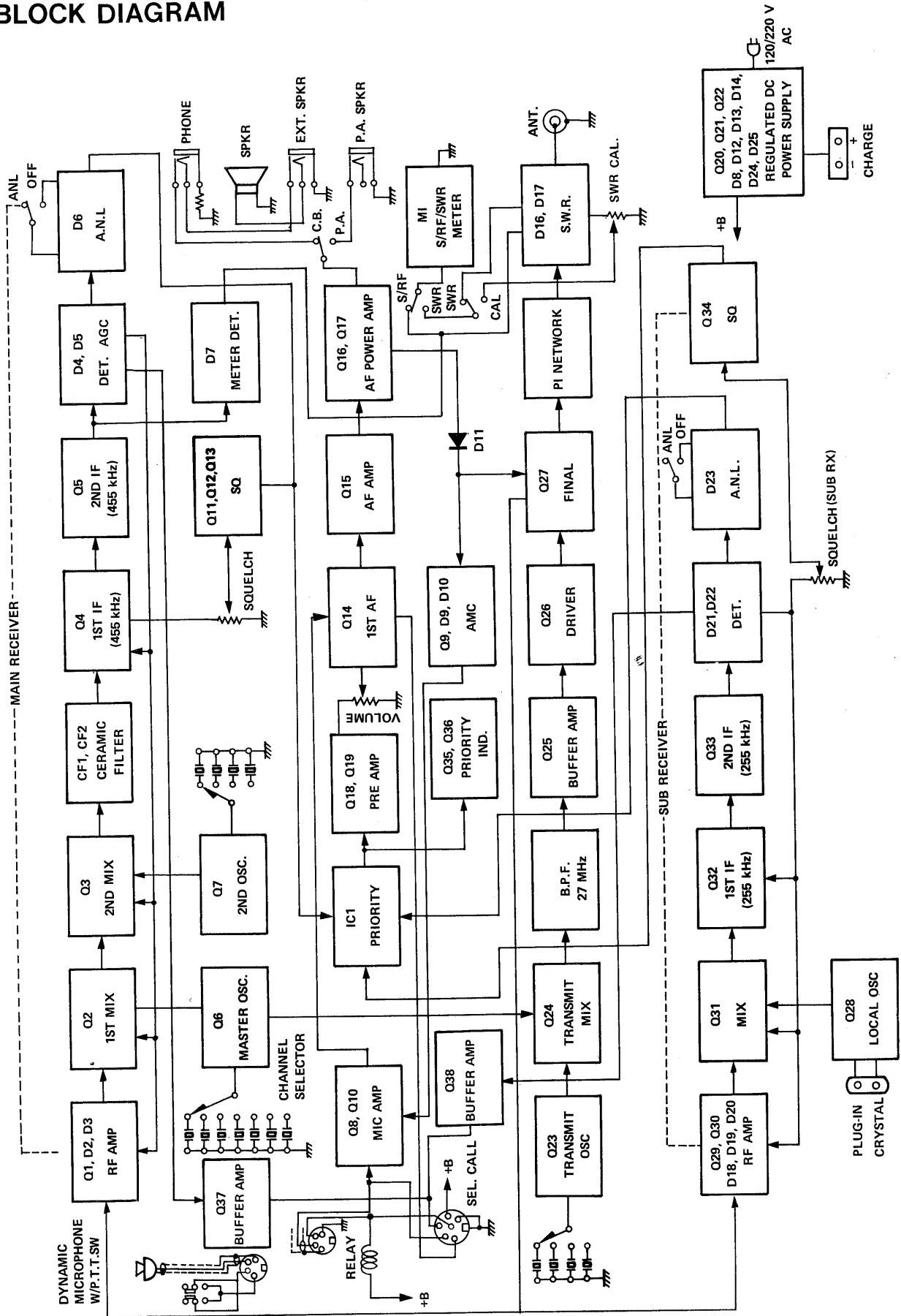

AF/POWER SUPPLY P.C.B. PARTS LOCATION BOTTOM VIEW

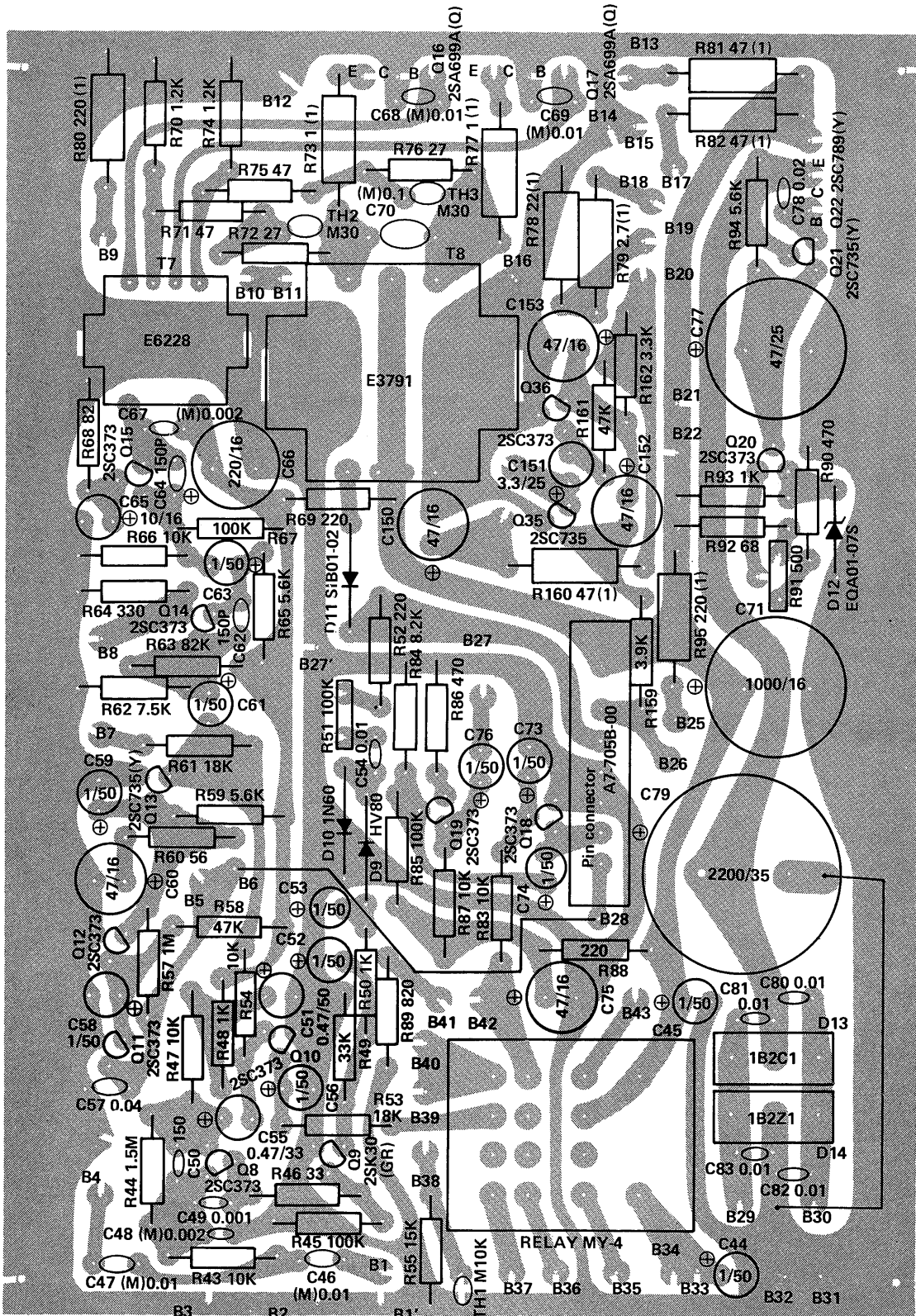

S.W.R. P.C.B. PARTS LOCATION

TOP VIEW

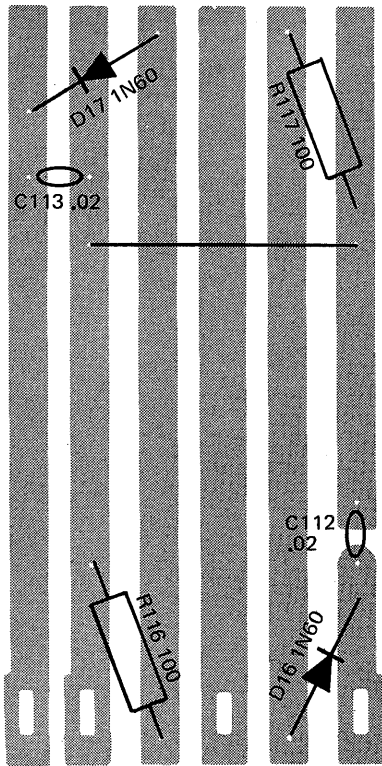

REAR VIEW

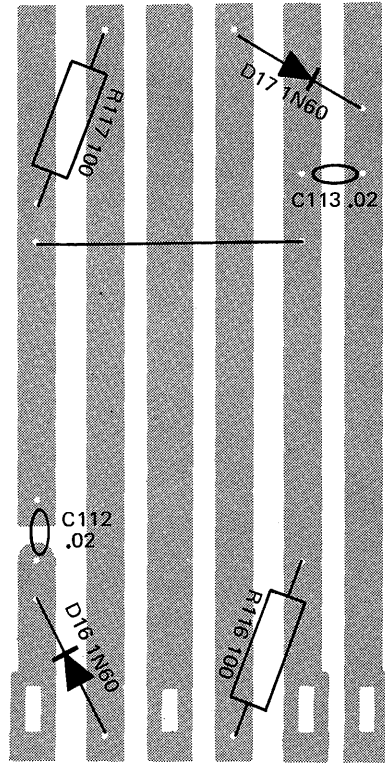

BUFFER AMP P.C.B. PARTS LOCATION

TOP VIEW

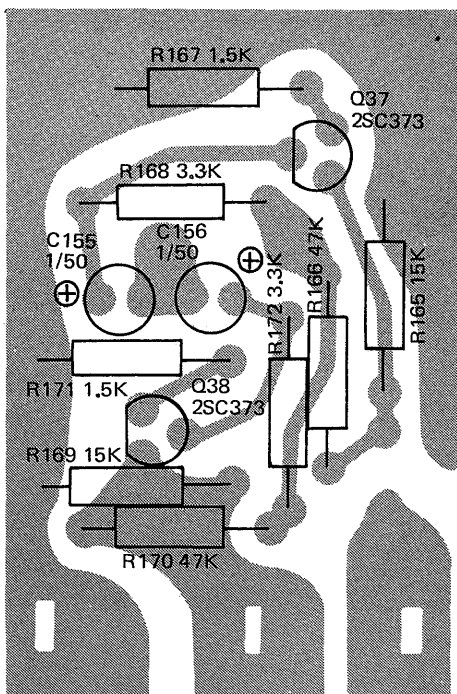

REAR VIEW

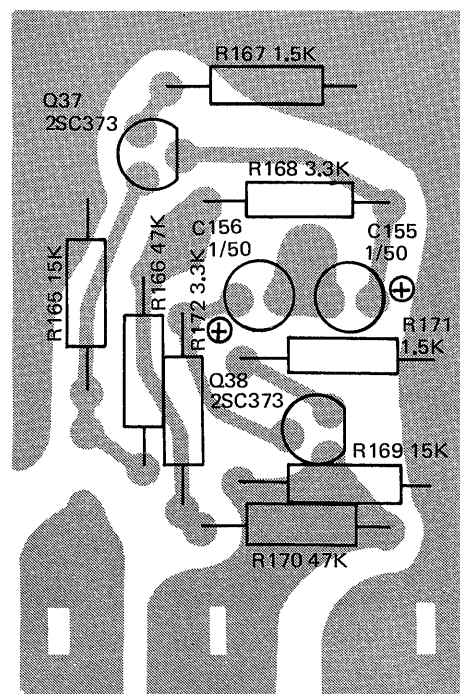

WIRING DIAGRAM

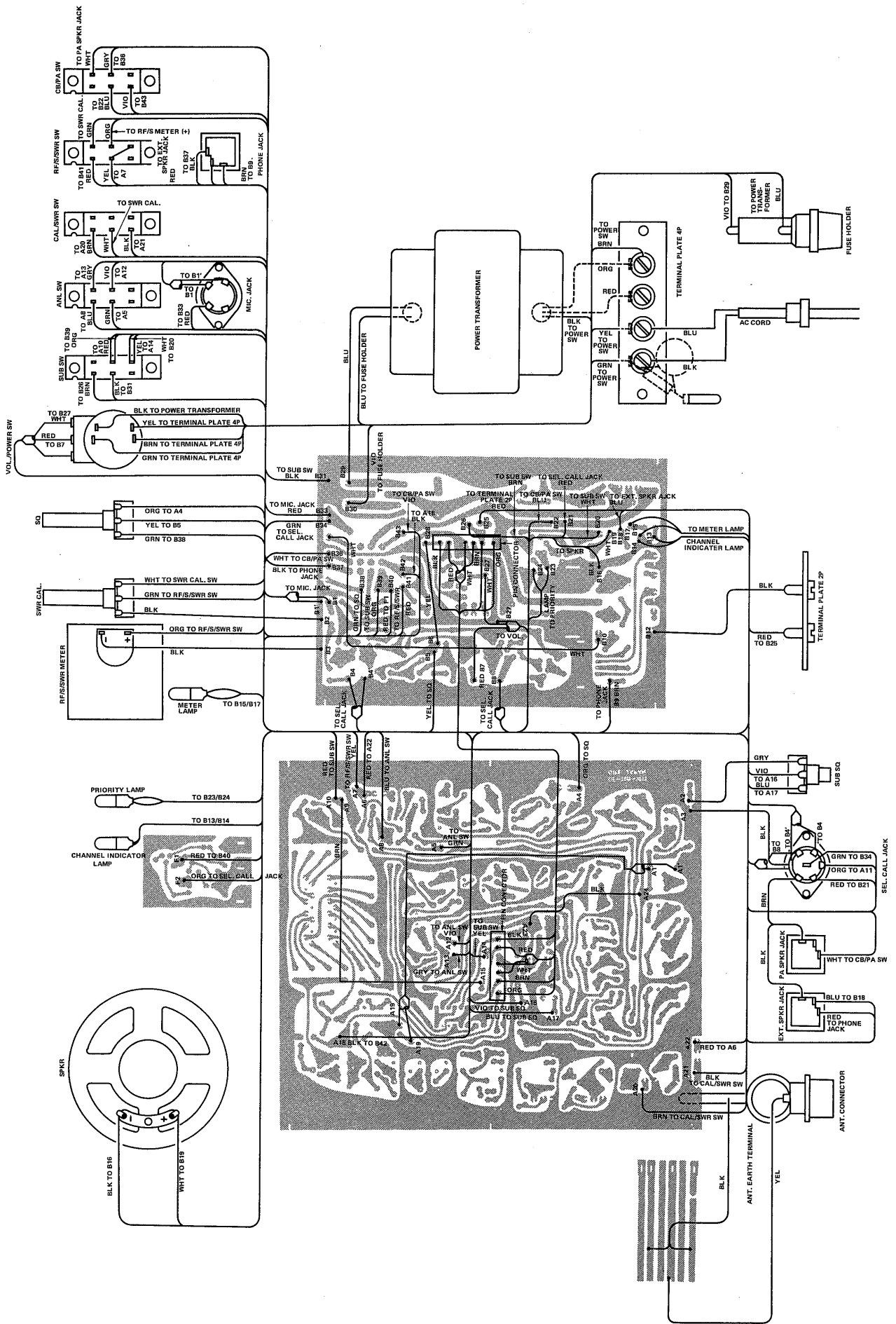

TROUBLE SHOOTING

Sympton	Possible Cause
1) Channel lamp and meter lamp do not light and/or set fails to operate when Power is ON.	A) Faulty Power cord. B) Defective Power switch. C) Fuse blown. D) Defective Q20, Q21 and/or Q22.
2) Fuse blows when Power switch is ON.	A) Defective Q16 or Q17. B) Defective Q26 and/or Q27. C) Defective C71.
3) Pilot lamp lighted but no sound on any channel.	A) Defective Speaker or defective Ext. speaker Jack J5. B) Defective Q14, Q15, Q16 and Q17 or associated circuit components. C) Defective Q6 or associated circuit components. D) Defective Q7 or associated circuit components. E) Defective IC1. F) Faulty Volume control
4) Does not receive on main RX. TX : OK SUB RX : OK	A) Defective Q7 or associated circuit components. B) Defective Q34, IC and/or misadjustment of subreceiver squelch control R151.
5) Does not receive on SUB RX MAIN : OK	A) Defective Q28 or associated circuit components. B) Defective Q34 and/or IC1.
6) Priority lamp does not go on and off.	A) Defective Q35 and/or Q36. B) Defective PL3.
7) Reception sensitivity low.	A) Faulty RF amplifier or Mixer circuit components. B) Faulty IF amplifier circuit.
8) Main receiver squelch control does not operate.	A) Defective Q11, Q12 and/or Q13. B) Faulty R20 and/or R57.
9) SUB receiver squelch control does not operate.	A) Defective Q34 and/or IC1. B) Faulty R151 or R152.
10) Does not transmit. RX : OK	A) Faulty P.T.T. switch. B) Defective Q23 or associated circuit components.
11) RF power low.	A) Mismatched antenna. B) Mismatched π network. C) Low supply voltage.
12) No modulation Receiver : OK	A) Defective microphone cartridge. B) Faulty microphone cord. C) Defective Q8, Q9, Q10 and/or associated circuit components. D) Defective modulator transformer.

RF P.C. BOARD

Ref. No.	Description			handic Stock Number	MFR's Part Number
CAPACITORS					
C1	Ceramic	0.01 μ F		-20% ~ +80%	990477 MC-70
C2	Ceramic	10pF		\pm 10%	990377 FCC-50
C3	Ceramic	0.01 μ F		-20% ~ +80%	990477 MC-70
C4	Electrolytic	10 μ F	16WV	-10% ~ +50%	990036 CE04W1C100C
C5	Ceramic	0.01 μ F		-20% ~ +80%	990477 MC-70
C6	Electrolytic	1 μ F	50WV	-10% ~ +75%	990008 CE04W1H010
C7	Ceramic	0.04 μ F		-20% ~ +80%	990491 MC-100
C8-11	Ceramic	0.01 μ F		-20% ~ +80%	990477 MC-70
C12	Ceramic	150pF		\pm 10%	990309 FC-80
C13-15	Ceramic	0.01 μ F		-20% ~ +80%	990477 MC-70
C16	Ceramic	1pF		\pm 0.5pF	990666 FCC-50
C17	Mylar	0.04 μ F	50WV	\pm 20%	990127
C18	Ceramic	0.04 μ F		-20% ~ +80%	990491 MC-100
C19, 20	Mylar	0.04 μ F	50WV	\pm 20%	990127
C21	Ceramic	0.04 μ F		-20% ~ +80%	990491 MC-100
C22	Ceramic	100pF		\pm 10%	990428 FCC-120
C23	Mylar	0.01 μ F	50WV	\pm 20%	990099
C24, 25	Electrolytic	0.47 μ F	50WV	-10% ~ +75%	990001 CE04W1HR47
C26	Electrolytic	1 μ F	50WV	-10% ~ +75%	990008 CE04W1H010
C27	Mylar	0.02 μ F	50WV	\pm 20%	990106
C28, 29	Electrolytic	3.3 μ F	25WV		990603 CE04W1E3R3
C30	Mylar	0.01 μ F	50WV	\pm 20%	990099
C31	Mylar	0.001 μ F	50WV	\pm 20%	990085
C32, 33	Ceramic	0.01 μ F		-20% ~ +80%	990477 MC-70
C34	Ceramic	0.04 μ F		-20% ~ +80%	990491 MC-100
C35	Ceramic	150pF		\pm 10%	990442 FCC-150
C36	Ceramic	15pF		\pm 10%	990386 FCC-60
C37	Ceramic	150pF		\pm 10%	990442 FCC-150
C38	Ceramic	0.01 μ F		-20% ~ +80%	990477 MC-70
C39	Ceramic	10pF		\pm 10%	990377 FCC-50
C40	Mylar	0.001 μ F	50WV	\pm 20%	990085
C41	Ceramic	68pF		\pm 10%	990414 FCC-100
C42	Ceramic	0.01 μ F		-20% ~ +80%	990477 MC-70
C43	Ceramic	33pF		\pm 10%	990393 FCC-80
C44-83	Used in AF/Power supply P.C.B.				
C84	Mylar	0.001 μ F	50WV	\pm 20%	990085
C85	Ceramic	0.01 μ F		-20% ~ +80%	990477 MC-70
C86	Polystyrene	100pF	125WV	\pm 10%	990407
C87	Ceramic	180pF	NPO	\pm 10%	990435 FCC-150
C88	Polystyrene	130pF	125WV	\pm 10%	990400
C89, 90	Ceramic	0.01 μ F		-20% ~ +80%	990477 MC-70
C91	Ceramic	150pF		\pm 10%	990456 FCR-120
C92, 93	Ceramic	0.01 μ F		-20% ~ +80%	990477 MC-70
C94	Ceramic	5pF		\pm 0.5pF	990377 FCC-50
C95	Ceramic	150pF		\pm 10%	990456 FCR-120
C96	Ceramic	5pF		\pm 0.5pF	990377 FCC-50
C97-99	Ceramic	0.01 μ F		-20% ~ +80%	990477 MC-70
C100	Polystyrene	470pF	125WV	\pm 5%	990197
C101	Ceramic	0.01 μ F		-20% ~ +80%	990477 MC-70
C102	Polystyrene	470pF	125WV	\pm 5%	990197
C103	Ceramic	15pF		\pm 10%	990386 FCC-60
C104	Polystyrene	470pF	125WV	\pm 5%	990197

Ref. No.	Description				handic Stock Number	MFR's Part Number
C105	Ceramic	0.01 μ F		-20% ~ +80%	990477	MC-70
C106	Ceramic	100pF		\pm 10%	990428	FCC-120
C107	Ceramic	10pF		\pm 10%	990377	FCC-50
C108	Ceramic	33pF		\pm 10%	990393	FCC-80
C109	Polystyrene	360pF		\pm 5%	990190	
C110	Ceramic	22pF		\pm 10%	990680	FCC-60
C111	Polystyrene	180pF		\pm 5%	990687	
C112,113	Used in S.W.R. P.C.B.					
C114	Ceramic	100pF		\pm 10%	990428	FCC-120
C115	Ceramic	68pF		\pm 10%	990414	FCC-100
C116	Ceramic	0.01 μ F		-20% ~ +80%	990477	MC-70
C117	Ceramic	3pF		\pm 0.5pF	990673	FCC-50
C118	Ceramic	0.01 μ F		-20% ~ +80%	990477	MC-70
C119	Ceramic	10pF		\pm 10%	990377	FCC-50
C120	Ceramic	0.01 μ F		-20% ~ +80%	990477	MC-70
C121	Electrolytic	10 μ F	16WV	-10% ~ +50%	990036	CE04W1C100C
C122-126	Ceramic	0.01 μ F		-20% ~ +80%	990477	MC-70
C127	Mylar	0.04 μ F	50WV	\pm 20%	990127	
C128	Ceramic	0.01 μ F		-20% ~ +80%	990477	MC-70
C129,130	Mylar	0.04 μ F	50WV	\pm 20%	990127	
C131	Ceramic	0.04 μ F		-20% ~ +80%	990491	MC-100
C132	Electrolytic	4.7 μ F	16WV		990561	
C133	Mylar	0.04 μ F	50WV	\pm 20%	990127	
C134	Electrolytic	3.3 μ F	25WV		990603	
C135	Mylar	0.04 μ F	50WV	\pm 20%	990127	
C136	Ceramic	0.04 μ F		-20% ~ +80%	990491	MC-100
C137	Ceramic	120pF		\pm 10%	990435	FCC-120
C138	Mylar	0.04 μ F	50WV	\pm 20%	990127	
C139	Mylar	0.02 μ F	50WV	\pm 20%	990106	
C140,141	Electrolytic	1 μ F	50WV	-10% ~ +75%	990008	CE04W1H010
C142	Electrolytic	3.3 μ F	25WV		990603	CE04W1E3R3
C143	Mylar	0.02 μ F	50WV	\pm 20%	990106	
C144	Mylar	0.002 μ F	50WV	\pm 20%	990092	
C145	Mylar	0.01 μ F	50WV	\pm 20%	990099	
C146,147	Electrolytic	47 μ F	16WV	-10% ~ +50%	990043	CE04W1C470B
C148	Electrolytic	1 μ F	50WV	-10% ~ +75%	990008	CE04W1H010
C149	Mylar	0.01 μ F	50WV	\pm 20%	990099	
C150-153	Used in AF/Power supply P.C.B.					
C154	Ceramic	0.01 μ F	1KWV		990694	CKA3A230
RESISTORS						
R1	Carbon film	8.2K Ω	1/4W	\pm 5%	950665	ERD-14TJ-822
R2	Carbon film	1K Ω	1/4W	\pm 5%	950511	ERD-14TJ-102
R3	Carbon film	1.5M Ω	1/4W	\pm 5%	954235	ERD-14TJ-155
R4	Carbon film	270 Ω	1/4W	\pm 5%	950413	ERD-14TJ-271
R5	Carbon film	3.3K Ω	1/4W	\pm 5%	950595	ERD-14TJ-332
R6	Carbon film	220K Ω	1/4W	\pm 5%	950903	ERD-14TJ-224
R7	Carbon film	100 Ω	1/4W	\pm 5%	950343	ERD-14TJ-101
R8	Carbon film	470 Ω	1/4W	\pm 5%	950455	ERD-14TJ-471
R9	Carbon film	27K Ω	1/4W	\pm 5%	950749	ERD-14TJ-273
R10	Carbon film	470K Ω	1/4W	\pm 5%	950959	ERD-14TJ-474
R11	Carbon film	1K Ω	1/4W	\pm 5%	950511	ERD-14TJ-102
R12	Carbon film	470 Ω	1/4W	\pm 5%	950455	ERD-14TJ-471

Ref. No.	Description	handic Stock Number	MFR's Part Number
R13	Carbon film 10K Ω 1/4W \pm 5%	950679	ERD-14TJ-103
R14	Carbon film 470K Ω 1/4W \pm 5%	950959	ERD-14TJ-474
R15	Carbon film 1K Ω 1/4W \pm 5%	950511	ERD-14TJ-102
R16, 17	Carbon film 2.2K Ω 1/4W \pm 5%	950567	ERD-14TJ-222
R18	Carbon film 27K Ω 1/4W \pm 5%	950749	ERD-14TJ-273
R19	Carbon film 150K Ω 1/4W \pm 5%	950875	ERD-14TJ-154
R20	Potentiometer 10K Ω 0.1W	984102	EVN-J0AA00B14
R21	Carbon film 1K Ω 1/4W \pm 5%	950511	ERD-14TJ-102
R22	Carbon film 33K Ω 1/4W \pm 5%	950763	ERD-14TJ-333
R23	Carbon film, 470 Ω 1/4W \pm 5%	950455	ERD-14TJ-471
R24	Carbon film 4.7K Ω 1/4W \pm 5%	950623	ERD-14TJ-472
R25	Carbon film 22K Ω 1/4W \pm 2%	950735	ERD-14TJ-223
R26	Carbon film 470 Ω 1/4W \pm 5%	950455	ERD-14TJ-471
R27	Carbon film 100 Ω 1/4W \pm 5%	950343	ERD-14TJ-101
R28	Carbon film 470 Ω 1/4W \pm 5%	950455	ERD-14TJ-471
R29	Potentiometer 20K Ω 0.1W \pm 5%	984109	EVN-J0AA00B24
R30	Carbon film 5.6K Ω 1/4W \pm 5%	950637	ERD-14TJ-562
R31	Carbon film 6.8K Ω 1/4W \pm 5%	950651	ERD-14TJ-682
R32	Used in Chassis assembly		
R33	Carbon film 150 Ω 1/4W \pm 5%	950371	ERD-14TJ-151
R34	Carbon film 150K Ω 1/4W \pm 5%	950875	ERD-14TJ-154
R35	Carbon film 1.8K Ω 1/4W \pm 5%	950553	ERD-14TJ-182
R36	Carbon film 220 Ω 1/4W \pm 5%	950399	ERD-14TJ-221
R37	Carbon film 100 Ω 1/4W \pm 5%	950343	ERD-14TJ-101
R38	Carbon film 3.3K Ω 1/4W \pm 5%	950595	ERD-14TJ-332
R39	Carbon film 8.2K Ω 1/4W \pm 5%	950665	ERD-14TJ-822
R40	Carbon film 1K Ω 1/4W \pm 5%	950511	ERD-14TJ-102
R41	Carbon film 220 Ω 1/4W \pm 5%	950399	ERD-14TJ-221
R42	Carbon film 330 Ω 1/4W \pm 5%	950427	ERD-14TJ-331
R43-95	Used in AF/Power supply P.C.B.		
R96	Carbon film 4.7K Ω 1/4W \pm 5%	950623	ERD-14TJ-472
R97	Carbon film 6.8K Ω 1/4W \pm 5%	950651	ERD-14TJ-682
R98	Carbon film 1K Ω 1/4W \pm 5%	950511	ERD-14TJ-102
R99	Carbon film 470 Ω 1/4W \pm 5%	950455	ERD-14TJ-471
R100	Carbon film 68K Ω 1/4W \pm 5%	950819	ERD-14TJ-683
R101	Carbon film 470K Ω 1/4W \pm 5%	950959	ERD-14TJ-474
R102	Carbon film 47K Ω 1/4W \pm 5%	950791	ERD-14TJ-473
R103	Carbon film 47 Ω 1/4W \pm 5%	950287	ERD-14TJ-470
R104	Carbon film 470 Ω 1/4W \pm 5%	950455	ERD-14TJ-471
R105	Carbon film 2.2K Ω 1/4W \pm 5%	950567	ERD-14TJ-222
R106	Carbon film 15K Ω 1/4W \pm 5%	950707	ERD-14TJ-153
R107	Carbon film 2.2 Ω 1/4W \pm 5%	950063	ERD-14TJ-2R2
R108	Carbon film 82 Ω 1/4W \pm 5%	950329	ERD-14TJ-820
R109	Carbon film 10 Ω 1/4W \pm 5%	950175	ERD-14TJ-100
R110	Carbon film 68 Ω 1/4W \pm 5%	950315	ERD-14TJ-680
R111	Carbon film 120 Ω 1/4W \pm 5%	950357	ERD-14TJ-121
R112	Carbon film 1K Ω 1/2W \pm 10%	954130	ERD-12TK-102
R113	Carbon film 300 Ω 1/4W \pm 5%	950420	ERD-14TJ-301
R114	Carbon film 1K Ω 1/2W \pm 10%	954130	ERD-12TK-102
R115	Carbon film 1.8M Ω 1/2W \pm 10%	954228	ERD-12TK-185
R116, 117	Used in S.W.R. P.C.B.		
R118	Potentiometer 2K Ω (B) 0.1W	984-95	EVN-J0AA00B23
R119	Deletion		
R120	Carbon film 150K Ω 1/4W \pm 5%	950875	ERD-14TJ-154

Ref. No.	Description				handic Stock Number	MFR's Part Number
R121,122	Carbon film	470Ω	1/4W	±5%	950455	ERD-14TJ-471
R123	Carbon film	1KΩ	1/4W	±5%	950511	ERD-14TJ-102
R124	Carbon film	4.7KΩ	1/4W	±5%	950623	ERD-14TJ-472
R125	Carbon film	10KΩ	1/4W	±5%	950679	ERD-14TJ-103
R126	Carbon film	220KΩ	1/4W	±5%	950903	ERD-14TJ-224
R127	Carbon film	390Ω	1/4W	±5%	950441	ERD-14TJ-391
R128,129	Carbon film	10KΩ	1/4W	±5%	950679	ERD-14TJ-103
R130	Carbon film	120Ω	1/4W	±5%	950357	ERD-14TJ-121
R131	Carbon film	470Ω	1/4W	±5%	950455	ERD-14TJ-471
R132	Carbon film	22KΩ	1/4W	±5%	950735	ERD-14TJ-223
R133	Carbon film	220KΩ	1/4W	±5%	950903	ERD-14TJ-224
R134	Carbon film	470Ω	1/4W	±5%	950455	ERD-14TJ-471
R135	Carbon film	100Ω	1/4W	±5%	950343	ERD-14TJ-101
R136	Carbon film	470Ω	1/4W	±5%	950455	ERD-14TJ-471
R137	Carbon film	220KΩ	1/4W	±5%	950903	ERD-14TJ-224
R138	Carbon film	10KΩ	1/4W	±5%	950679	ERD-14TJ-103
R139	Carbon film	100KΩ	1/4W	±5%	950847	ERD-14TJ-104
R140	Carbon film	1KΩ	1/4W	±5%	950511	ERD-14TJ-102
R141	Carbon film	470Ω	1/4W	±5%	950455	ERD-14TJ-471
R142	Carbon film	4.7KΩ	1/4W	±5%	950623	ERD-14TJ-472
R143	Carbon film	33KΩ	1/4W	±5%	950763	ERD-14TJ-333
R144	Carbon film	680Ω	1/4W	±5%	950483	ERD-14TJ-681
R145	Carbon film	100Ω	1/4W	±5%	950343	ERD-14TJ-101
R146	Carbon film	470Ω	1/4W	±5%	950455	ERD-14TJ-471
R147	Carbon film	8.2KΩ	1/4W	±5%	950665	ERD-14TJ-822
R148	Carbon film	150Ω	1/4W	±5%	950371	ERD-14TJ-151
R149	Carbon film	270Ω	1/4W	±5%	950413	ERD-14TJ-271
R150	Carbon film	2.7KΩ	1/4W	±5%	950581	ERD-14TJ-272
R151	Used in Chassis assembly					
R152	Potentiometer	50KΩ	0.1W		984116	EVN-J0AA00B54
R153	Carbon film	22KΩ	1/4W	±5%	950735	ERD-14TJ-223
R154	Carbon film	56KΩ	1/4W	±5%	950805	ERD-14TJ-563
R155	Carbon film	27KΩ	1/4W	±5%	950749	ERD-14TJ-273
R156	Carbon film	100KΩ	1/4W	±5%	950847	ERD-14TJ-104
R157	Potentiometer	50KΩ	0.1W		984116	EVN-J0AA00B54
R158	Carbon film	47KΩ	1/4W	±5%	950791	ERD-14TJ-473
R159-162	AF/Power supply P.C.B.					
R163	Carbon film	1.8MΩ	1/2W	±10%	954228	ERD-12TK-185
R164	Carbon film	15KΩ	1/4W	±5%	950707	ERD-14TJ-153
SEMICONDUCTORS						
Q1	Transistor	silicon			992101	2SC784(O)
Q2,3	Transistor	silicon			992038	2SC371(O)
Q4,5	Transistor	silicon			992059	2SC372(Y)
Q6,7	Transistor	silicon			992038	2SC371(O)
Q8-22	Used in AF/Power supply P.C.B.					
Q23	Transistor	silicon			992038	2SC371(O)
Q24	F.E.T.	silicon			992003	3SK45
Q25	Transistor	silicon			992087	2SC735(Y)
Q26	Transistor	silicon			992332	2SC1728
Q27	Transistor	silicon			992325	2SC1816
Q28	Transistor	silicon			992038	2SC371(O)
Q29	Transistor	silicon			992101	2SC784(O)
Q30	Transistor	silicon			992318	2SC394(O)
Q31	Transistor	silicon			992038	2SC371(O)
Q32,33	Transistor	silicon			992059	2SC372(Y)

Ref. No.	Description	handic Stock Number	MFR's Part Number
Q34	Transistor silicon	992066	2SC373
D1,2	Diode silicon	992150	1S1555
D3	Diode silicon	992164	HV80
D4-7	Diode germanium	992143	1N60
D8	Diode zener (7V)	992311	EQA01-07S
D9-14	Used in AF/Power supply P.C.B.		
D15	Diode zener (33V)	992185	AW01-33
D16,17	Used in S.W.R. P.C.B.		
D18,19	Diode silicon	992150	1S1555
D20	Diode silicon	992164	HV80
D21-23	Diode germanium	992143	1N60
D24	Diode zener (7V)	992199	EQA01-07S
D25	Diode zener (5V)	992304	EQA01-05S
TH-4	Thermistor	992346	SDT500
IC-1	Integrated circuit	992353	SN7405A
COIL/TRANSFORMER/FILTER			
T1	ANT coil (27MHz)	995150	TKXN23345X
T2	RF coil (27MHz)	995157	TKXC23344X
T3	MIX coil (10.6MHz)	995164	TKXN23346X
T4	IFT (455kHz)	995178	YOC15001A
T5	IFT (455kHz)	995185	YMC15002A
T6	OSC coil (37MHz)	995192	10PN0-091
T7,8	Used in AF/Power supply P.C.B.		
T9	B.P.F. (27MHz)	995199	TKXC15950N
T10	BUFFER coil (27MHz)	995206	TKXC23343N
T11	DRIVE coil (27MHz)	995115	8SND-061
T12	ANT coil (27MHz)	995101	113CN2544A0
T13	RF coil (27MHz)	995045	1624B
T14	IFT (255kHz)	995437	7JE-402123N6
T15	IFT (255kHz)	995444	7JE-101102M0
T16	IFT (255kHz)	995437	7JE-402123N6
T17,18	IFT (255kHz)	995444	7JE-101102M0
L1	RF choke coil (2mH)	995297	EL0610-202K
L2	RF choke coil (10 μ H)	995094	LF1-100K
L3,4	B.P.F. (27MHz)	995213	TKXN23571Z
L5,6	RF choke coil (2 μ H)	995220	4LNC-054
L7	T NET coil (27MHz)	995227	8SNF-064
L8	π NET coil (27MHz)	995031	10PNP-028
L9	RF choke coil	995465	4LNC-092
L10	RF choke coil (2.2 μ H)	995010	LF4-2R2K
CF-1	Ceramic filter	995451	LF-B6S
CF-2	Ceramic filter	995458	LF-A10
CRYSTALS			
X1	Crystal 37.600MHz	452298	
X2	Crystal 37.650MHz	452305	
X3	Crystal 37.700MHz	452312	
X4	Crystal 37.750MHz	452319	
X5	Crystal 37.800MHz	452326	
X6	Crystal 37.850MHz	452333	
X7	Crystal 37.690MHz (handic 2305A)	452340	

Ref. No.	Description	handic Stock Number	MFR's Part Number
X8	Crystal 10.180MHz	452347	
X9	Crystal 10.170MHz	452354	
X10	Crystal 10.160MHz	452361	
X11	Crystal 10.140MHz	452368	
X12	Crystal 10.635MHz	452375	
X13	Crystal 10.625MHz	452382	
X14	Crystal 10.615MHz	452389	
X15	Crystal 10.595MHz	452396	
MISCELLANEOUS			
S1-3	Rotary switch		SRA-2424
TP1-13	Test pin	599449	C.P.T
RA1,2	Resistor array		7403
	Crystal socket	599099	S2-101P01
	Pin connector		A7-705B-00
②	RF P.C.B.		GE-20B-5013

AF/POWER SUPPLY P.C.B. PARTS LIST

Ref. No.	Description	handic Stock Number	MFR's Part Number
CAPACITORS			
C44,45	Electrolytic 1 μ F 50WV -10% ~ +75%	990008	CE04W1H010
C46,47	Mylar 0.01 μ F 50WV \pm 20%	990099	
C48	Mylar 0.002 μ F 50WV \pm 20%	990092	
C49	Ceramic 0.001 μ F -20% ~ +80%	990463	MC-60
C50	Ceramic 150pF \pm 20%	990456	FCR-120
C51	Electrolytic 0.47 μ F 50WV -10% ~ +75%	990001	CE04W1HR47
C52,53	Electrolytic 1 μ F 50WV -10% ~ +75%	990008	CE04W1H010
C54	Ceramic 0.01 μ F -20% ~ +80%	990477	MC-70
C55	Electrolytic 0.47 μ F 50WV -10% ~ +75%	990001	CE04W1HR47
C56	Electrolytic 1 μ F 50WV -10% ~ +75%	990008	CE04W1H010
C57	Ceramic 0.04 μ F -20% ~ +80%	990491	MC-100
C58,59	Electrolytic 1 μ F 50WV -10% ~ +75%	990008	CE04W1H010
C60	Electrolytic 47 μ F 16WV -10% ~ +50%	990043	CE04W1C470B
C61	Electrolytic 1 μ F 50WV -10% ~ +75%	990008	CE04W1H010
C62	Ceramic 150pF \pm 20%	990456	FCR-120
C63	Electrolytic 1 μ F 50WV -10% ~ +75%	990008	CE04W1H010
C64	Ceramic 150pF \pm 20%	990456	FCR-120
C65	Electrolytic 10 μ F 16WV -10% ~ +50%	990036	CE04W1C100C
C66	Electrolytic 220 μ F 16WV -10% ~ +50%	990057	CE04W1C221
C67	Mylar 0.002 μ F 50WV \pm 20%	990092	
C68,69	Mylar 0.01 μ F 50WV \pm 20%	990099	
C70	Mylar 0.1 μ F 50WV \pm 20%	990134	
C71	Electrolytic 1000 μ F 16WV	990701	
C72	Ceramic 300pF \pm 10%	990344	FC-90
C73,74	Electrolytic 1 μ F 50WV -10% ~ +75%	990008	CE04W1H0101
C75	Electrolytic 47 μ F 16WV -10% ~ +50%	990043	CE04W1C470B
C76	Electrolytic 1 μ F 50WV -10% ~ +75%	990008	CE04W1H010
C77	Electrolytic 47 μ F 25WV -10% ~ +75%	990715	CE04W1E470C
C78	Ceramic 0.02 μ F -20% ~ +80%	990484	MC-75
C79	Electrolytic 2200 μ F 35WV	990708	
C80-83	Ceramic 0.01 μ F -20% ~ +80%	990477	MC-70
C150	Electrolytic 47 μ F 16WV -10% ~ +50%	990043	CE04W1C470B
C151	Electrolytic 3.3 μ F 25WV	990603	CE04W1E3R3
C152,153	Electrolytic 47 μ F 16WV -10% ~ +50%	990043	CE04W1C470B
RESISTORS			
R43	Carbon film 10K Ω 1/4W \pm 5%	950679	ERD-14TJ-103
R44	Carbon film 1.5M Ω 1/4W \pm 5%	954235	ERD-14TJ-155
R45	Carbon film 100K Ω 1/4W \pm 5%	950847	ERD-14TJ-104
R46	Carbon film 33 Ω 1/4W \pm 5%	950259	ERD-14TJ-330
R47	Carbon film 10K Ω 1/4W \pm 5%	950679	ERD-14TJ-103
R48	Carbon film 1K Ω 1/4W \pm 5%	950511	ERD-14TJ-102
R49	Carbon film 33K Ω 1/4W \pm 5%	950763	ERD-14TJ-333
R50	Carbon film 1K Ω 1/4W \pm 5%	950511	ERD-14TJ-102
R51	Potentiometer 100K Ω 0.1W	984123	EVN-J0AA00B15
R52	Carbon film 220 Ω 1/4W \pm 5%	950399	ERD-14TJ-221
R53	Carbon film 18K Ω 1/4W \pm 5%	950721	ERD-14TJ-183
R54	Carbon film 10K Ω 1/4W \pm 5%	950679	ERD-14TJ-103
R55	Carbon film 15K Ω 1/4W \pm 5%	950707	ERD-14TJ-153
R57	Carbon film 1M Ω 1/4W \pm 5%	951015	ERD-14TJ-105
R58	Carbon film 47K Ω 1/4W \pm 5%	950791	ERD-14TJ-473

Ref. No.	Description				handic Stock Number	MFR's Part Number
R59	Carbon film	5.6K Ω	1/4W	$\pm 5\%$	950637	ERD-14TJ-562
R60	Carbon film	56 Ω	1/4W	$\pm 5\%$	950301	ERD-14TJ-560
R61	Carbon film	18K Ω	1/4W	$\pm 5\%$	950721	ERD-14TJ-183
R62	Carbon film	7.5K Ω	1/4W	$\pm 5\%$	950658	ERD-14TJ-752
R63	Carbon film	82K Ω	1/4W	$\pm 5\%$	950833	ERD-14TJ-823
R64	Carbon film	330 Ω	1/4W	$\pm 5\%$	950427	ERD-14TJ-331
R65	Carbon film	5.6K Ω	1/4W	$\pm 5\%$	950637	ERD-14TJ-562
R66	Carbon film	10K Ω	1/4W	$\pm 5\%$	950679	ERD-14TJ-103
R67	Carbon film	100K Ω	1/4W	$\pm 5\%$	950847	ERD-14TJ-104
R68	Carbon film	82 Ω	1/4W	$\pm 5\%$	950329	ERD-14TJ-820
R69	Carbon film	220 Ω	1/4W	$\pm 5\%$	950399	ERD-14TJ-221
R70	Carbon film	1.2K Ω	1/4W	$\pm 5\%$	950525	ERD-14TJ-122
R71	Carbon film	47 Ω	1/4W	$\pm 5\%$	950287	ERD-14TJ-470
R72	Carbon film	27 Ω	1/4W	$\pm 5\%$	950245	ERD-14TJ-270
R73	Metal film	1 Ω	1W		954151	
R74	Carbon film	1.2K Ω	1/4W	$\pm 5\%$	950525	ERD-14TJ-122
R75	Carbon film	47 Ω	1/4W	$\pm 5\%$	950287	ERD-14TJ-470
R76	Carbon film	27 Ω	1/4W	$\pm 5\%$	950245	ERD-14TJ-270
R77	Metal film	1 Ω	1W		954151	
R78	Metal film	22 Ω	1W		954165	
R79	Metal film	2.7 Ω	1W		954158	
R80	Metal film	220 Ω	1W		954221	
R81,82	Metal film	47 Ω	1W		954214	
R83	Carbon film	10K Ω	1/4W	$\pm 5\%$	950679	ERD-14TJ-103
R84	Carbon film	8.2K Ω	1/4W	$\pm 5\%$	950665	ERD-14TJ-822
R85	Carbon film	100K Ω	1/4W	$\pm 5\%$	950847	ERD-14TJ-104
R86	Carbon film	470 Ω	1/4W	$\pm 5\%$	950455	ERD-14TJ-471
R87	Carbon film	10K Ω	1/4W	$\pm 5\%$	950679	ERD-14TJ-103
R88	Carbon film	220 Ω	1/4W	$\pm 5\%$	950399	ERD-14TJ-221
R89	Carbon film	820 Ω	1/4W	$\pm 5\%$	950497	ERD-14TJ-821
R90	Carbon film	470 Ω	1/4W	$\pm 5\%$	950455	ERD-14TJ-471
R91	Potentiometer	500 Ω	0.1W			EVN-K0AA00B52
R92	Carbon film	68 Ω	1/4W	$\pm 5\%$	950315	ERD-14TJ-680
R93	Carbon film	1K Ω	1/4W	$\pm 5\%$	950511	ERD-14TJ-102
R94	Carbon film	5.6K Ω	1/4W	$\pm 5\%$	950637	ERD-14TJ-562
R95	Metal film	220 Ω	1W		954221	
R159	Carbon film	3.9K Ω	1/4W	$\pm 5\%$	950609	ERD-14TJ-392
R160	Metal film	47 Ω	1W		954214	
R161	Carbon film	47K Ω	1/4W	$\pm 5\%$	950791	ERD-14TJ-473
R162	Carbon film	3.3K Ω	1/4W	$\pm 5\%$	950595	ERD-14TJ-332
SEMICONDUCTORS						
Q8	Transistor	silicon			992066	2SC373
Q9	F.E.T.	silicon			992276	2SK30A(GR)
Q10-12	Transistor	silicon			992066	2SC373
Q13	Transistor	silicon			992087	2SC735(Y)
Q14,15	Transistor	silicon			992066	2SC373
Q16,17	Transistor	silicon			992017	2SA699A(O)
Q18-20	Transistor	silicon			992066	2SC373
Q21	Transistor	silicon			992087	2SC735(Y)
Q22	Transistor	silicon			992339	2SC789(Y)
Q35	Transistor	silicon			992087	2SC735(Y)
Q36	Transistor	silicon			992066	2SC373

Ref. No.	Description	handic Stock Number	MFR's Part Number
D9	Diode silicon	992164	HV80
D10	Diode germanium	992143	1N60
D11	Diode silicon	992171	SIB01-02
D12	Diode zener	992199	EQA01-07S
D13	Diode silicon	992290	1B2C1
D14	Diode silicon	992297	1B2Z1
TH1	Thermistor	992213	M-10K
TH2,3	Thermistor	992262	M-30
TRANSFORMER			
T7	AF transformer (INPUT)	995381	E6228
T8	AF transformer (MOD.)	995402	E3791
MISCELLANEOUS			
⑬	Relay Pin connector AF/Power supply P.C.B.		MY-4 A7-705B-00 GE-20C-5019

S.W.R. P.C.B. PARTS LIST

Ref. No.	Description	handic Stock Number	MFR's Part Number
C112,113	Ceramic 0.02 μ F -20% ~ +80%	990484	MC-75
R116,117	Carbon film 100 Ω 1/4W \pm 5%	950343	ERD-14TJ-101
D16,17	Diode germanium S.W.R. P.C.B.	992143	1N60 GE-20D-5029

BUFFER AMP P.C.B. PARTS LIST

Ref. No.	Description	handic Stock Number	MFR's Part Number
C115,156	Electrolytic 1 μ F 50WV	990008	CE04W1H010
R165	Carbon film 15K Ω 1/4W	950707	ERD-14TJ-153
R166	Carbon film 47K Ω 1/4W	950791	ERD-14TJ-473
R167	Carbon film 1.5K Ω 1/4W	950539	ERD-14TJ-152
R168	Carbon film 3.3K Ω 1/4W	950595	ERD-14TJ-332
R169	Carbon film 15K Ω 1/4W	950707	ERD-14TJ-153
R170	Carbon film 47K Ω 1/4W	950791	ERD-14TJ-473
R171	Carbon film 1.5K Ω 1/4W	950539	ERD-14TJ-152
R172	Carbon film 3.3K Ω 1/4W	950595	ERD-14TJ-332
Q37,38	Transistor silicon P.C.B.	992066	2SC373 GE-20D-5266

CHASSIS ASSEMBLY

Ref. No.	Description	handic Stock Number	MFR's Part Number
SWITCHES			
S4,5 (13)	CB. transceiver/P.A. amplifier SW		T-807AB 5X30FD1S
S6,7 (13)	RF. power & S meter/S.W.R. SW		T-807AB 5X30FD1S
S8 (13)	Calibration/S.W.R. SW		T-807AB 5X30FD1S
S9,10 (13)	Automatic noise limiter SW		T-807AB 5X30FD1S
S11,12 (13)	SUB receiver SW		T-807AB 5X30FD1S
VOLUMES			
R32 (15) (S14,15)	Volume control/Power switch 50K Ω (A)	984074	VJ11A-SF21-50KA EVC-B6M-K30A54
R56 (16)	MAIN squelch control 50K Ω (C)	984025	VM10A-5KC
R119 (17)	S.W.R. calibration 50K Ω (C)	984081	VM10A-50KB
R151 (27)	SUB squelch control 5K Ω (C)	984025	VM10A-5KC
MISCELLANEOUS			
(28)	DIN connector 6P	599645	CS-260
(12)	DIN connector 4P		CS-240
(14) (22)	Phone jack		SG7625
(30)	Antenna connector	599428	SO-239
	Antenna earth terminal	599330	GE-19D-4646
(8)	Speaker		C065A03
	Wrapping post		GE-18D-4022
(11)	Meter		KL-218L-84
T19 (23)	Power transformer		K4310
	AC cord (handic 2305A)		CEE class 0 type
	AC cord (handic 2305B)		EP N013
(26)	Cord stopper	599659	3P-4
(18)	Terminal plate 4P		
(29)	Terminal plate 2P		
(25)	Fuse holder		SN2050
F1	Fuse	599680	2A
	Lamp 12V 40mA L=280m/m PL1		
	Lamp 12V 40mA L=200m/m PL2		
	Lamp 12V 40mA L=300m/m PL3		
	Lamp grommet	599743	BU-687
	Heat sink	599470	GE-19D-4751
(2)	Channel knob		GE-19D-4978
(1)	Volume knob	599043	GE-19D-4631
(18)	Channel dial board (handic 2305A)		GE-20D-5001
(10)	Channel dial board (handic 2305B)		GE-20D-5031
(5)	Channel window		GE-19D-4981
(4)	Lamp jewel		GE-19D-4980
(21)	Chassis		GE-19D-4974
(31)	Bonnet		GE-19A-4975
(7)	Escutcheon		GE-19A-4976
(3)	Front panel		GE-19B-4977
(6)	Speaker cloth		GE-20D-5091
	Cloth for bonnet		GE-19C-4982
(32)	Foot		7103
	Poly case		GE-20B-5183

Ref. No.	Description	handic Stock Number	MFR's Part Number
⑳	Model label Voltage change label Caution label Microphone SW. sponge		GE-20D-5018 GE-20D-5037 GE-20D-3036B handic 50 GE-20D-5134
U.S.A. model only			
R32 ⑮ (S14,15) L11 C157,158 D26	Volume control/Power switch 50KΩ(A) Line choke coil Mylar 0.02μF 50WV ±20% Diode silicon AC line cord		VJ11A-SF21-50KA E5701 1N4141

TRANSISTOR LEAD IDENTIFICATIONS

- A: 2SC371(O), 2SC372(O), 2SC372(Y), 2SC373, 2SC735(Y), 2SC394(O), 2SC784(O)
 B: 2SA699A(Q)
 C: 2SC1816
 D: 2SC1728
 E: 2SK30A(GR)
 F: 3SK45

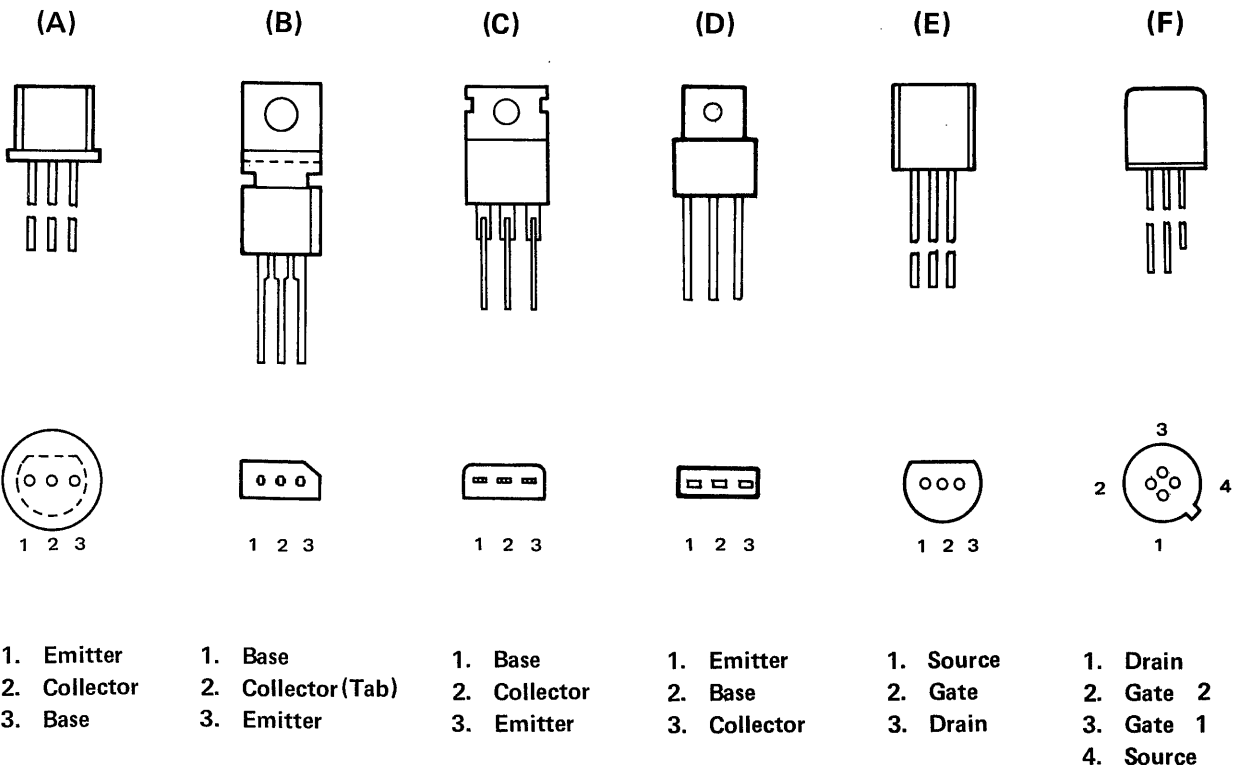

SCHEMATIC DIAGRAM

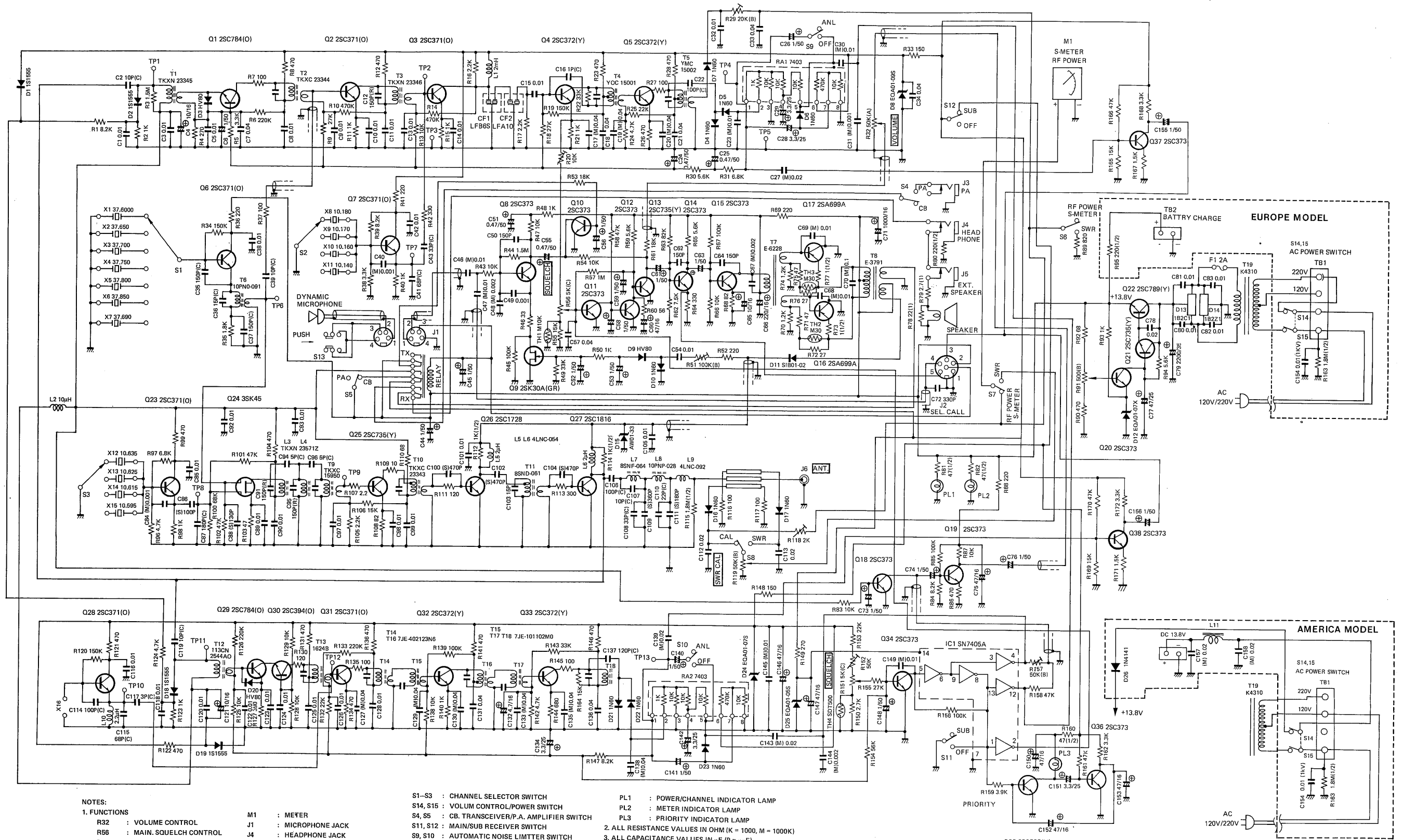

NOTES:

1. FUNCTIONS

- R32 : VOLUME CONTROL
- R56 : MAIN SQUELCH CONTROL
- R151 : SUB. SQUELCH CONTROL
- R119 : S.W.R CALIBRATION
- F1 : FUSE 2A

M1

- J1 : MICROPHONE JACK
- J4 : HEADPHONE JACK
- J2 : SEL CALL JACK
- J5 : EXTERNAL SPEAKER JACK
- J6 : ANTENNA JACK (SO-239 TYPE)

S1-S3 : CHANNEL SELECTOR SWITCH

- S14, S15 : VOLUM CONTROL/POWER SWITCH
- S4, S5 : CB. TRANSCIEVER/P.A. AMPLIFIER SWITCH
- S11, S12 : MAIN/SUB RECEIVER SWITCH
- S9, S10 : AUTOMATIC NOISE LIMITTER SWITCH
- S13 : MICROPHONE PUSH TO TALK SWITCH
- S8 : CALIBRATION/S.W.R SWITCH
- S6, S7 : RF. POWER & S METER/S.W.R SWITCH

PL1 : POWER/CHANNEL INDICATOR LAMP

- PL2 : METER INDICATOR LAMP
- PL3 : PRIORITY INDICATOR LAMP

2. ALL RESISTANCE VALUES IN OHM (K = 1000, M = 1000K)
3. ALL CAPACITANCE VALUES IN μ F (P = μ P F)
4. RATING OR TYPE NUMBER OF COMPONENT PARTS ARE SUBJECT TO CHANGE FOR IMPROVEMENT WITHOUT NOTICE

CHASSIS DISASSEMBLY DIAGRAM

