



Cobra 21XLR
40-Channel
Citizens Band 2-Way
Mobile Radio



Cobra Communications Product Group

DYNASCAN CORPORATION

6460 W. Cortland Street
Chicago, Illinois 60635

Instruction Manual
for
Cobra 21XLR
40-Channel
Citizens Band Solid State
2-Way Radio



Cobra Communications Product Group
DYNASCAN CORPORATION
6460 W. Cortland Street
Chicago, Illinois 60635

THE CB STORY

The Citizens Band lies between the shortwave broadcast and 10-meter amateur radio bands, and was established by law in 1949. The Class D two-way communications service was opened in 1959. (CB also includes a Class A business band and Class C remote control frequencies.) Acquiring the Class D license requires no detailed technical or Morse-code knowledge that is required for a "Ham" license.

In March, 1975, the FCC reduced the cost of a CB license from \$20 to \$4. One license can be good for any number of sets used by a given family or business. Once you receive your Class D license for your equipment, anyone may use it.

For example, though the equipment must be licensed to someone over 18 years of age, a child can use the equipment to talk to another child, or an employee can use the equipment as part of his or her routine services. However, final responsibility of legal operation rests with the CB licensee.

NOTE

FCC regulations permit only "transmissions" (one party to another) rather than "broadcasts" (to a wide audience). Thus, advertising is not allowed on CB channels because it is *broadcasting*.

**HAVE
A GOOD DAY
TODAY
AND
A BETTER DAY
TOMORROW!**

TABLE OF CONTENTS

Section I: Introduction	3
Frequency Range	3
FCC Warning	4
Section II: Specifications	5
Section III: Installation	
Location	7
Mounting and Connection	7
Ignition Noise Interference	8
Antenna Matching	8
Base Station Operation	9
External Speaker	9
Public Address	10
Section IV: Operation	
Controls and Indicators	11
Control Functions	11
Indicator Functions	13
Operating Procedure to Receive	13
Operating Procedure to Transmit	13
Alternate Microphones and Installation	14
Section V: Maintenance and Adjustment	17
Section VI: Appendix	
Ten Code	18
A Few Rules That Should Be Obeyed	19
How Your CB Can Serve You	20
Use Channel 9 for Emergency Messages Only	21
Warrant Service Instructions	22
Limited 90-Day Warranty	23

Section I

Introduction

The Cobra 21XLR has been designed to provide high level, trouble-free performance in the Citizens Radio Service which is comprised of the following frequency assignments:

Channel	Channel Frequency in MHz	Channel	Channel Frequency in MHz
1	26.965	21	27.215
2	26.975	22	27.225
3	26.985	23	27.255
4	27.005	24	27.235
5	27.015	25	27.245
6	27.025	26	27.265
7	27.035	27	27.275
8	27.055	28	27.285
9	27.065	29	27.295
10	27.075	30	27.305
11	27.085	31	27.315
12	27.105	32	27.325
13	27.115	33	27.335
14	27.125	34	27.345
15	27.135	35	27.355
16	27.155	36	27.365
17	27.165	37	27.375
18	27.175	38	27.385
19	27.185	39	27.395
20	27.205	40	27.405

To insure that you obtain the maximum performance from your Cobra 21XLR please read carefully the following control descriptions and operating instructions. These frequencies are generated and accurately controlled by a phase lock loop (PLL) circuit, comprised of the latest “state of the art” integrated circuit technology, thereby ensuring high reliability and excellent frequency stability on the above channels.

FCC WARNING*

1. Operation of this equipment requires a valid Station License issued by the Federal Communications Commission. Do not transmit with your equipment until you have received your License. Illegal operation can result in severe penalties. Be certain you have read Part 95 of the FCC Rules and Regulations, before operating your station.
2. License applications are to be made on FCC Form 505, available from your nearest field office. (A copy of this form is included with your new COBRA transceiver.)
3. You are required to maintain a current copy of Part 95 of the FCC Rules, as part of your Station records. Copies of Part 95 are available from the Superintendent of Documents, GPO, Washington, D.C. 20402.
4. Your Station License is to be posted in accordance with paragraph 95.101 of the Rules and an executed Transmitter Identification Card (FCC Form 452-C) is to be attached to each transmitter. (A copy of this form also is included with your new COBRA transceiver.)
5. FCC Rules require that ALL transmitter adjustments other than those supplied by the manufacturer as front panel operating controls, be made by, or under the supervision of, the holder of an FCC-issued 1st or 2nd Class Radio Operator License.
6. Replacement or substitution, of crystals, transistors, regular diodes or any other part of a unique nature, with parts other than those recommended by Dynascan, may cause violation of the technical regulations of Part 95 of the FCC Rules, or violation of the Type Acceptance requirements of Part 2 of the Rules.

*Excerpted from Part 95 of the FCC Rules and Regulations.

Section II Specifications

GENERAL

Channels	40.
Frequency Range	26.965 to 27.405 MHz.
Frequency Control	Phase Lock Loop (PLL).
Frequency Tolerance	0.005%.
Operating Temperature Range	-30°C to +50°C.
Microphone	Plug-in type; dynamic.
Input Voltage	13.8 VDC nom. (reversible ground).
Current Drain	<i>Transmit:</i> AM full mod. 2A (nominal). <i>Receive:</i> Squelched, 0.5; full audio output 1.5A (nominal).
Size	9- 3/8 "L x 6-1/4 "W x 2-1/8 "H.
Weight	3- 7/8 pounds.
Antenna Connector	UHF, SO239.
Semiconductors	21 transistors, 17 Diodes, 6 integrated circuits.
Meter	Illuminated, indicates relative power output and received signal strength.

TRANSMITTER

Power Output	4 watts.
Modulation	High- and low-level Class B.
Frequency Response	300 to 3000 Hz.
Output Impedance	500 ohms, unbalanced.

RECEIVER

Sensitivity	Less than $1\mu\text{V}$ for 10DB(S+N)/N.
Selectivity	6dB @ 7KHz, 60dB @10KHz.
Image Rejection	80dB. typical
Adjacent-Channel Rejection	60dB. typical
I.F. Frequencies	Double conversion, 1st: 10.695MHz. 2nd: 455KHz.
Automatic Gain Control (AGC)	Less than 10dB change in audio output for inputs from 10 to 50,000 microvolts.
Squelch	Adjustable; threshold less than $1\mu\text{V}$.
Audio Output Power	4 watts.
Frequency Response	300 to 3000 Hz.
Distortion	Less than 7 % @ 4 watts @ 1000 Hz.
Built-in Speaker	8 ohms, round.
External Speaker (Not Supplied)	8 ohms; disables internal speaker when connected.

PA SYSTEM

Power Output	4 watts into external speaker.
External Speaker for PA (Not Supplied)	8 ohms; when PA-CB switch in in PA, the PA speaker also monitors the receiver.

Section III

Installation

LOCATION

Plan the location of the transceiver and microphone bracket before starting the installation. Select a location that is convenient for operation and does not interfere with the driver or passengers in the vehicle. In automobiles, the transceiver is usually mounted to the underneath of the dash panel, with the microphone bracket beside it.

MOUNTING AND CONNECTION

The COBRA 21XLR is supplied with a universal mounting bracket. The transceiver is held in the bracket by four bolts, permitting adjustment at the most convenient angle.

The bracket must be mounted with the machine screws and nuts supplied. The mounting must be mechanically strong and also provide a good electrical connection to the chassis of the vehicle. Proceed as follows to mount the transceiver:

1. After you have determined the most convenient location in your vehicle, hold the COBRA 21XLR with mounting bracket in the exact location desired. If nothing will interfere with mounting it in the desired position, remove the mounting bracket and use it as a template to mark the location for the mounting bolts. Before drilling the holes, make sure nothing will interfere with the installation of the mounting bolts.
2. Connect the antenna cable plug to the standard receptacle on the rear panel. Most CB antennas are terminated with a type PL-259 plug and mate with the receptacle.
3. Connect the DC power input wire with the fuse to +13.8 VDC. This wire extends from the rear panel. In automobile installation, +13.8 VDC is usually obtained from the accessory contact on the ignition switch. This prevents the set from being left on accidentally when the driver leaves the car and also permits operating the unit without the engine running. Locate the accessory contact on most ignition switches by tracing the power wire from the AM broadcast receiver in the car.

4. Connect the black leads to 13.8 VDC. This is usually the chassis of the car: **Any convenient location with good electrical contact (remove paint) may be used.**
5. Mount the microphone bracket on the right side of the transceiver or near the transceiver, using two screws supplied. When mounting in an automobile, place the bracket under the dash so the microphone is readily accessible.

Ignition Noise Interference

Use of a mobile receiver at low signal levels is normally limited by the presence of electrical noise. The primary source of noise in automobile installations is from the generator and ignition system in the vehicle. Under most operating conditions, when signal level is adequate, the background noise does not present a serious problem. Also, when extremely low level signals are being received, the transceiver may be operated with vehicle engine turned off. The unit requires very little current and therefore will not significantly discharge the vehicle battery.

Even though the COBRA 21XLR has a selectable automatic noise limiter, in some installations ignition interference may be high enough to make good communications impossible. The electrical noise may come from several sources. Many possibilities exist and variations between vehicles require different solutions to reduce the noise. Consult your COBRA dealer or a 2-way radio technician for help in locating and correcting the source of severe noise.

Antenna Matching

Since the maximum allowable power output of the transmitter is limited by the FCC, the antenna is one important factor affecting transmission distance. Only a properly matched antenna system will allow maximum power transfer from the 50 ohm transmission line to the radiating element. In mobile installations (cars, trucks, boats, etc.), an antenna system that is non-directional should be used.

A vertically polarized quarter-wavelength whip antenna provides the most reliable operation and greatest range. The shorter, loaded-type whip antennas are more attractive, compact and adequate for applications where the maximum possible distance is not required. Also the loaded whips do not present the problems of height imposed by the full quarter-wavelength whip.

Mobile whip antennas utilize the metal body of the vehicle as a ground plane.

When mounted at a corner of the vehicle they are **slightly directional**, in the direction of the body of the vehicle. For all practical purposes, however, the radiation pattern is non-directional. The slight directional characteristic will be observed only at extreme distances. A standard antenna connector (Type SO-239) is provided on the transceiver for easy connection to a standard PL-259 cable termination.

If the transceiver is not mounted on a metal surface, it is necessary to run a separate ground wire from the unit to a good metal electrical ground in the vehicle. When installed in a boat, the transceiver will not operate at maximum efficiency without a ground plate, unless the vessel has a steel hull.

Before installing the transceiver in a boat, consult your dealer for information regarding an adequate grounding system and prevention of electrolysis between fittings in the hull and water.

Base Station Operation

(Operation from 110-120 VAC, house current)

To operate your transceiver from your home or office, using the regular house current as the power source, you will require the DYNASCAN Model CA-20 Power Pak which has been specially designed for the purpose. It is available as optional equipment from your dealer. It consists of a precision-built AC-DC power converter that delivers the required 13.8 VDC power for operation of the transceiver. The CA-20 operates from any 120-volt, 60 Hz power source. Simply connect the red (+) and Black (-) leads of the transceiver to the corresponding terminals of the CA-20.

NOTE

Do not attempt to operate the COBRA 21XLR by connecting the transceiver directly to 110 volts AC.

When the CA-20 Power Pak is used with the transceiver for base station operation, any Citizens Band beam, dipole, ground plane or vertical antenna may be used. A ground plane vertical antenna will provide the most uniform horizontal coverage.

External Speaker

The external speaker jack (EXT. SPK.) on the rear panel is used for remote receiver monitoring. The external speaker should have 8 ohms impedance and be able to handle at least 4 watts. When the external speaker is plugged in, the internal speaker is disconnected.

Public Address

To use the transceiver as a public address system connect an external 8 ohm speaker (4 watts minimum) to the PA SPK. jack located on the rear panel. Direct away from the microphone to prevent acoustic feedback. Physical separation or isolation of the microphone and speaker is important when operating the PA at high output levels.

Section IV Operation

CONTROLS AND INDICATORS

There are seven controls and two indicators on the front panel of your COBRA 21XLR.

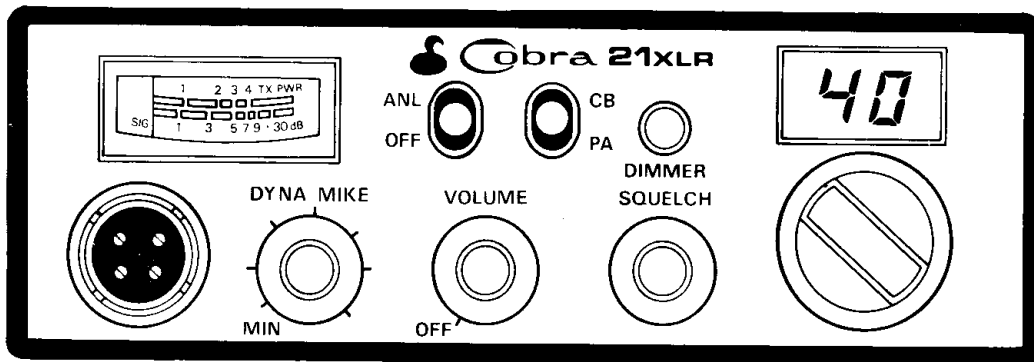

A. CONTROL FUNCTIONS

1. **OFF/ON/VOLUME.** Turn clockwise to apply power to the unit and to set the desired listening level.
2. **SQUELCH.** This control is used to cut off or eliminate receiver background noise in the absence of an incoming signal. For maximum receiver sensitivity it is desired that the control be adjusted only to the point where the receiver background noise or ambient background noise is eliminated. Turn fully counterclockwise then slowly clockwise until the receiver noise disappears. Any signal to be received must now be slightly stronger than the average received noise. Further clockwise rotation will increase the threshold level which a signal must overcome in order to be heard. Only strong signals will be heard at a maximum clockwise setting.
3. **CHANNEL SELECTOR.** This switch selects any one of the forty Citizens Band channels desired. The selected channel appears on the LED readout directly above the Channel Selector knob. Channel 9 has been reserved by the FCC for emergency communications involving the immediate safety of life of individuals or immediate protection of property. Channel 9 may also be used to render assistance to a motorist.

4. **ANL SWITCH.** In the ANL position the automatic noise limiter in the audio circuits is activated.
5. **PA/CB SWITCH.** Selects the mode of operation. In the CB position, the PA function is disabled and the unit will transmit and receive on the selected frequency. *The PA function should not be used unless a PA speaker is connected.*

To use this PA feature, a speaker having a voice coil impedance of 8 ohms and a power handling capability of at least four watts should be used. This speaker must be plugged into the PA SPKR jack at the rear of the transceiver. If the public address feature is to be used primarily for outdoor applications, the use of a weatherproof horn type public address speaker is recommended. The durability of this type speaker plus the inherent efficiency of such a speaker will provide more than adequate results when combined with the high audio output level available from the COBRA 21XLR. With the PA speaker connected as outlined previously, be sure that there is physical separation between the microphone and the speaker itself. If the speaker is located close to the microphone, acoustic feedback will result when the public address system is operated at high volume. A directional type outdoor speaker reduces the amount of isolation required. Some experimentation will determine the minimum amount of isolation required for a given sound level from the public address system.

NOTE

PA volume is controlled by adjusting the DYNAMIKE knob to the desired volume.

6. **DYNAMIKE.** Adjusts the microphone gain in the transmit and PA modes. This controls the gain to the extent that full talk power is available several inches away from the microphone. In the Public Address (PA) mode, the control functions as the volume control.
7. **DIMMER CONTROL.** Allows you to adjust the brightness of the LED channel readout for optimum intensity for day or night-time driving.

PRESS-TO-TALK MICROPHONE. The receiver and transmitter are controlled by the press-to-talk switch on the microphone. Press the switch and the transmitter is activated; release switch to receive. When transmitting, hold the microphone two inches from the mouth and speak clearly in a normal "voice". The radios come complete with a low-impedance (500 ohm) dynamic microphone. For installation instructions on other microphones, see next section, **ALTERNATE MICROPHONES AND INSTALLATION.**

B. INDICATOR FUNCTIONS

S-METER. Swings proportionally to the strength of the incoming signal.

RF METER. Swings proportionally to the RF output power.

OPERATING PROCEDURE TO RECEIVE

1. Place CB-PA switch in CB position.
2. Turn the set ON by turning the **VOLUME** control clockwise, until a click is heard.

NOTE

Microphone must be plugged in for receiver to operate.

3. Set the **VOLUME** for a comfortable listening level.
4. Listen to the background noise from the speaker. Turn the **SQUELCH** control slowly clockwise, until the noise just disappears. (No signal should be present.) Leave the control at this setting. The **SQUELCH** is now properly adjusted. The receiver will remain quiet until a signal is actually received. Do not advance the control too far, or some of the weaker signals will not be heard.
5. Set the **CHANNEL** selector switch to the desired channel.

OPERATING PROCEDURE TO TRANSMIT

1. Select the desired channel of transmission.
2. Set the **DYNAMIKE** control fully clockwise.
3. If the channel is clear, depress the push-to-talk switch on the microphone and speak in a normal voice.

ALTERNATE MICROPHONES AND INSTALLATION

For best results, the user should select a low-impedance dynamic type microphone or a transistorized microphone. Transistorized type microphones have a low output impedance characteristic. The microphones must be provided with a four-lead cable. The audio conductor and its shielded lead comprise two of the leads. The third lead is for transmit control and the fourth lead is ground (see schematic, Fig. 3). The microphone should provide the functions shown below:

4-Wire Mic Cable

Pin Number	Mic Cable Lead
1	Audio Shield
2	Audio Lead
3	Transmit Control
4	Receive Control

If the microphone to be used is provided with pre-cut leads, they must be revised as follows:

1. The leads should be cut so that they extend $7/16''$ beyond the plastic insulating jacket of the microphone cable. See Fig. 1 below.
2. All leads should be cut to the same length. Strip the ends of each wire $1/8''$ and tin the exposed wire.

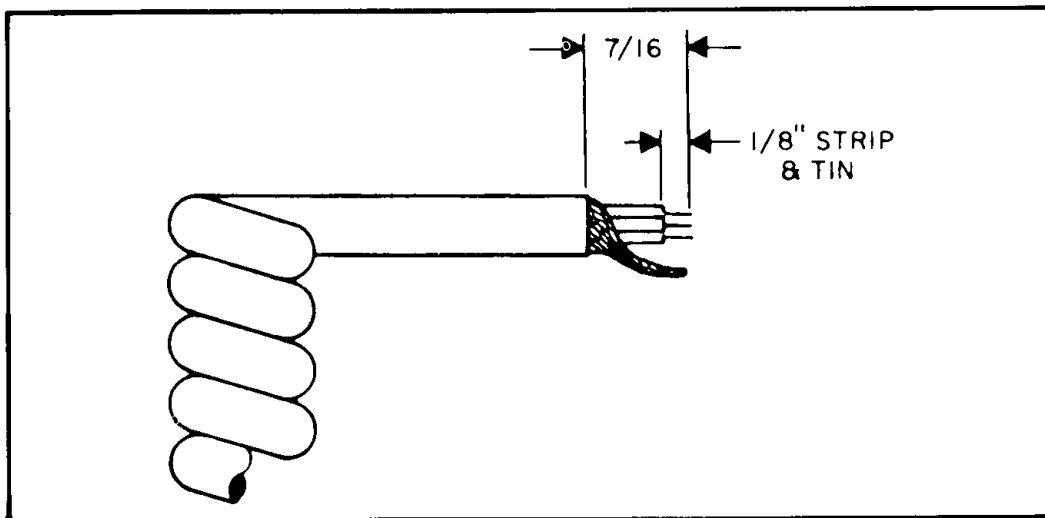

Fig. 1. Microphone cable preparation.

Before beginning the actual wiring, read carefully the circuit and wiring information provided with the microphone you select. Use the minimum heat required in soldering the connections. Keep the exposed wire lengths to a minimum to avoid shorting when the microphone plug is reassembled.

To wire the microphone cable to the plug provided, proceed as follows (see Fig. 2):

1. Remove the retaining screw.
2. Unscrew the housing from the pin receptacle body.
3. Loosen the two cable clamp retainer screws.
4. Feed the microphone cable through the housing, knurled ring and washer below.

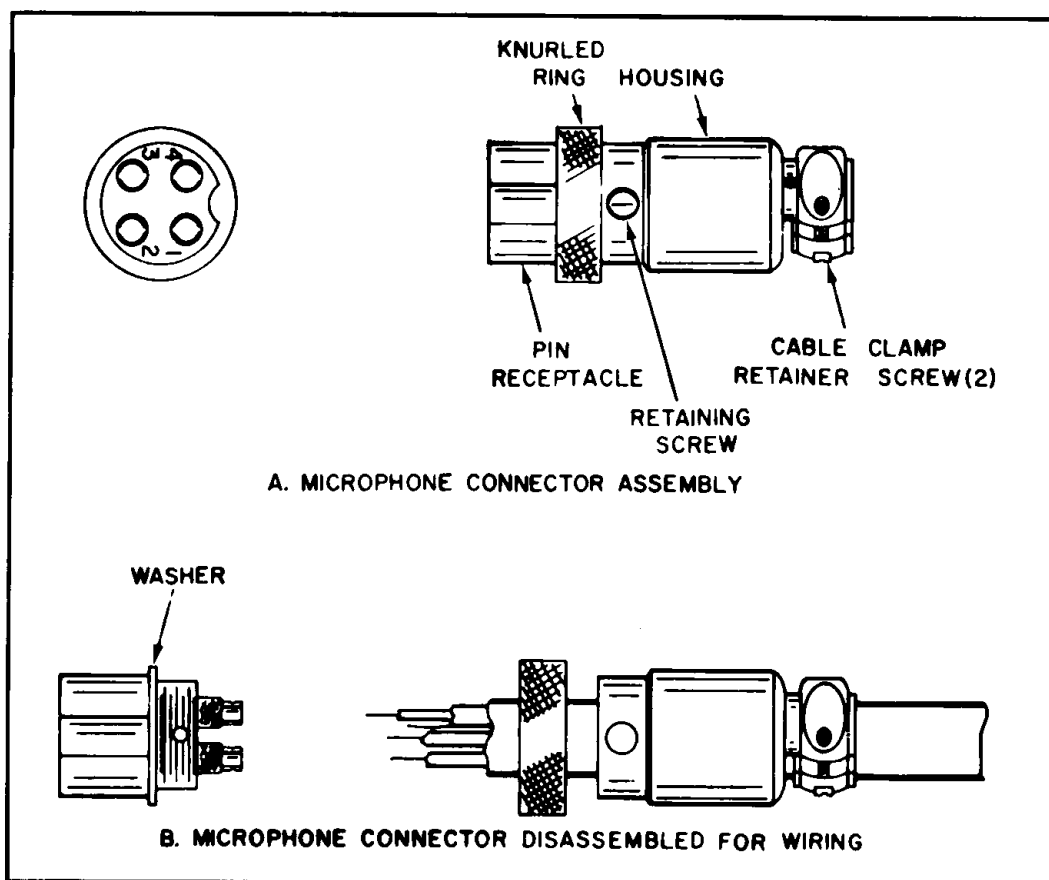

Fig. 2. Microphone plug wiring.

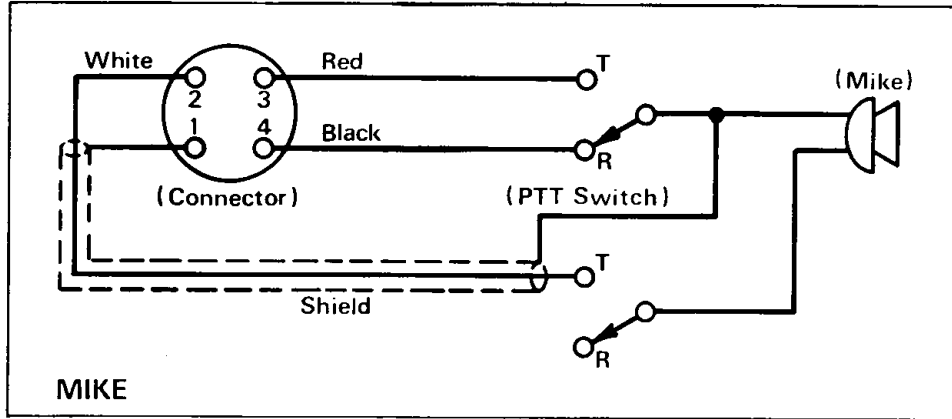

Fig. 3. Microphone and connector wiring diagram.

Section V

Maintenance and Adjustment

The COBRA 21XLR transceiver is specifically designed for the environment encountered in mobile installations. The use of all solid state circuitry and its light weight result in high reliability. Should a failure occur, however, replace parts only with identical parts. Do not substitute. Refer to the schematic diagram and parts list.

NOTE

If the performance described in the OPERATION and MAINTENANCE AND ADJUSTMENT sections is not obtained, review the operating instructions to insure that proper procedures were followed. If a problem still exists, refer to WARRANTY SERVICE INSTRUCTIONS elsewhere in this manual.

FCC WARNING

Federal law required that adjustment of the radio frequency section of this transceiver may not be made by a Citizens Band operator. Only a United States licensed First or Second Class commercial license holder may tune the transmitter section of this transceiver, per FCC part 95 section 95.97d.

Section VI

Appendix

Citizens Band radio operators have largely adopted the “10-code” for standard questions and answers. Its use permits faster communications and better understanding in noisy areas. The following table lists some of the more common codes and their meanings.

10 CODE

Code	Meaning	Code	Meaning
10-1	Receiving poorly	10-29	Time is up for contact
10-2	Receiving well	10-30	Does not conform to FCC rules
10-3	Stop transmitting	10-32	I will give you a radio check
10-4	OK, message received	10-33	EMERGENCY TRAFFIC
10-5	Relay message	10-34	Trouble at this station
10-6	Busy, stand by	10-35	Confidential information
10-7	Out of service, leaving air	10-36	Correct time is
10-8	In service, subject to call	10-37	Wrecker needed at
10-9	Repeat message	10-38	Ambulance needed at
10-10	Transmission completed, standing by	10-39	Your message delivered
10-11	Talking too rapidly	10-41	Please turn to channel
10-12	Visitors present	10-42	Traffic accident at
10-13	Advise Weather/Road conditions	10-43	Traffic Tie up at
10-16	Make pick up at	10-44	I have a message for you
10-17	Urgent business	10-45	All units within range please report
10-18	Anything for us?	10-50	Break channel
10-19	Nothing for you, return to base	10-60	What is next message number?
10-20	My location is	10-62	Unable to copy, use phone
10-21	Call by telephone	10-63	Net directed to
10-22	Report in person to	10-64	Net clear
10-23	Stand by	10-65	Awaiting your next message/assignment
10-24	Completed last assignment	10-67	All units comply
10-25	Can you contact	10-70	Fire at
10-26	Disregard last information		
10-27	I am moving to channel		
10-28	Identify your station		

10 CODE (Continued)

Code	Meaning	Code	Meaning
10-71	Proceed with transmission in sequence	10-91	Talk closer to mike
10-73	Speed trap at	10-92	Your transmitter is out of adjustment
10-75	You are causing interference	10-93	Check my frequency on this channel
10-77	Negative contact	10-94	Please give me a long count
10-81	Reserve hotel room for	10-95	Transmit dead carrier for 5 seconds
10-82	Reserve room for	10-99	Mission completed, all units secure
10-84	My telephone number is		
10-85	My address is		
10-89	Radio repairman needed at		
10-90	I have TVI	10-200	Police needed at

A FEW RULES THAT SHOULD BE OBEYED

1. You must identify **your** official licensed call sign at the beginning and end of every conversation.
2. You are not allowed to carry on a conversation with another station for more than five minutes at a time without taking a one-minute break, to give others a chance to use the channel.
3. You are not allowed to blast others off the air by over-powering them with illegally amplified transmitter power, or illegally high antennas.
4. You can't use CB to promote illegal activities.
5. You are not allowed to use profanity.
6. You may not play music in your CB.
7. You may not use your CB to sell merchandise or professional services.

HOW YOUR CB CAN SERVE YOU

- Warn of traffic tie ups ahead.
- Provide weather and road information.
- Provide help fast in event of emergency or breakdown.
- Suggest good spots to eat and sleep.
- Make long trips more interesting, and help keep you awake.
- Provide direct contact with your office or home.
- Make friends for you as you travel.
- Provide “local information” to find your destination.
- Help law enforcement officers by reporting drunk and reckless drivers.

Colonel Samuel S. Smith of the Missouri Highway Patrol called the number of drunken drivers, wrong-way drivers and speeders reported by CBers as “amazing.” He said, that even the “Smokey Bear” warnings don’t shake their beliefs that “the potential benefits of CB radio to law enforcement are so great that they far outweigh the disadvantages.” In regards to CB radar warnings to other CBers, Colonel Smith said cheerfully that “We’ve overheard warnings being relayed to truckers long after our operations have been discontinued . . . so we actually receive a residual benefit from these warnings.”

USE CHANNEL 9 FOR EMERGENCY MESSAGES ONLY

FCC gives the following examples of permitted and prohibited types of communications for use on Channel 9. These are guidelines and are not intended to be all-inclusive.

Permitted	Example Message
Yes	“A tornado sighted six miles north of town.”
No	“This is observation post number 10. No tornado sighted.”
Yes	“I am out of gas on Interstate 95.”
No	“I am out of gas in my driveway.”
Yes	“There is a four-car collision at Exit 10 on the Beltway, send police and ambulance.”
No	“Traffic is moving smoothly on the Beltway.”
Yes	“Base to Unit 1, the Weather Bureau has just issued a thunderstorm warning. Bring the sailboat into port.”
No	“Attention all motorists. The Weather Bureau advises that the snow tomorrow will accumulate 4 to 6 inches.”
Yes	“There is a fire in the building on the corner of 6th and Main Streets.”
No	“This is Halloween patrol unit number 3. Everything is quiet here.”

WARRANTY SERVICE INSTRUCTIONS

1. Refer to the **MAINTENANCE** section of your Cobra instruction manual for adjustments that may be applicable.
2. Defective parts removed from units which are within the 90-Day Limited Warranty period should be sent **PREPAID** to the Service Department listed below. Be sure to state the model and serial number of the unit from which the parts were removed and date the unit was purchased. These parts will be exchanged at no charge, under the terms of the Warranty.
3. If the above-mentioned procedures do not correct the problem you are experiencing with your unit, pack it securely (preferably in the original carton or double-packed). Enclose a letter describing the problem and include your name and address. Deliver to, or ship **PREPAID (UPS preferred)** to the nearest Cobra authorized service agency (see list enclosed with unit).

If your list of authorized Cobra service agencies has been misplaced, contact your local dealer for the name of your nearest service agency, or write to:

Service Department

Cobra Product Group
DYNASCAN CORPORATION
2815 West Irving Park Road
Chicago, Illinois 60618

LIMITED 90-DAY WARRANTY

DYNASCAN CORPORATION warrants to the original purchaser that its **COBRA** Citizens Band Radios, and the component parts thereof, will be free from defects in workmanship and materials for a period of ninety (90) days from the date of purchase.

DYNASCAN will, without charge, repair or replace, at its option, defective radios or component parts upon delivery to an authorized **COBRA** service contractor or the factory service department, accompanied by proof of the date of purchase in the form of a sales receipt.

To obtain warranty coverage, this CB radio must be registered by completing and mailing the enclosed warranty registration card to DYNASCAN Cobra Communications, P. O. Box 35148, Chicago, Illinois 60635 within five (5) days from the date of purchase.

Exclusions: This warranty does not apply in the event of misuse or abuse of the product or as a result of unauthorized alterations or repairs. It is void if the serial number is altered, defaced or removed.

As indicated in your product instruction booklet, certain **COBRA** models are suitable for dash board installation without modification of the dash. In other cases professional installation is recommended. In either event, DYNASCAN is not responsible for damages to the product or the automobile resulting from improper installation.

DYNASCAN shall not be liable for any consequential damages, including without limitation damages resulting from loss of use or cost of installation. Some states do not allow limitation of incidental or consequential damages, so the above limitation or exclusion may not apply to you.

This warranty gives you specific rights and you may also have other rights which vary from state to state.

For your convenience we suggest you contact your dealer, who may be authorized to make repairs or can refer you to the nearest service contractor. If warranty service cannot be obtained locally, please send the unit to Cobra Communications Service, 2815 West Irving Park Road, Chicago, Illinois 60618, properly packaged to avoid damage in shipment.

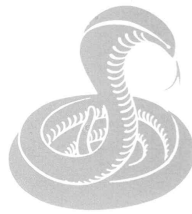

Cobra

Cobra Communications Product Group
DYNASCAN CORPORATION
6460 W. Cortland Street
Chicago, Illinois 60635