

AR / 240

gives you

800

channels in the palm of your hand



**...the world's
first synthesized 800
channel hand held
transceiver**

SPECIFICATIONS

Frequency Coverage:	144 to 148 MHz
Channel Spacing:	Every 5 KHz
Power Requirements:	9.6 VDC
Current Drain:	17 ma-standby 400 ma-transmit
Batteries:	Ni-cad battery pack included
Antenna Impedance:	50 ohms
Dimensions:	40 mm x 62 mm x 165 mm (1.6" x 2.5" x 6.5")
RF Output:	Better than 1.5 watts
Sensitivity:	Better than 5 microvolts

SUPPLIED ACCESSORIES

Telescoping whip antenna, ni-cad battery pack, charger.

"A staggering technical achievement"; "How can they get it into such a small size"; "Outperforms any rig I've ever had"; these are typical of the comments made by amateur radio operators after seeing and using the remarkable AR240 2 metre FM handheld transceiver. What does it mean to you? Well, at last you can really take your amateur radio with you, anywhere you want to go, because in this handheld unit, you have a complete synthesised 2 metre FM transceiver covering 144.000 - 147.995 KHz in 5 KHz steps. Also included are + and - 600 KHz repeater shifts and a crystal controlled tone burst unit.

The AR240 design is based on a very advanced PLL synthesiser which generates the local oscillator signal for a single conversion transmitter with an outstandingly clean signal and an output power well in excess of the 1.5Watt specification. Transmit audio is penetrating and easy to copy, helped in no small measure by the electret capacitor microphone built into the AR240. Tone burst for repeater access is generated by a 7.168 MHz crystal which is divided in a custom IC to give 1750 Hz literally "rock steady" tone.

The AR240 receiver is the equal of many full size base stations; samples measuring out at 12 dB SINAD for less than 0.2 microvolts. The receiver is fitted with a suffix "G" filter which as you will know, is perfectly matched to current or future European deviation standards. The recovered audio is exceptionally good, even on weak signals and the internal loudspeaker produces more than enough output for use anywhere. An external loudspeaker socket is provided should you wish to use either an earphone, or larger speaker unit.

Operation of the AR240 is very simple indeed. You simply select the frequency required on the direct reading frequency decade switches, switch on the transceiver, pull out the telescopic whip and speak into the microphone. Repeater shift is selected by a switch on the rear panel and tone burst activated by a secondary button on the PTT bar.

If you are considering a handheld 2 metre unit, there is nothing to compare with the AR240. Other units which are bulkier and heavier usually offer only six crystal controlled channels.

ADR AR240

RX CCT J-020-01

BANDPASS TUNING

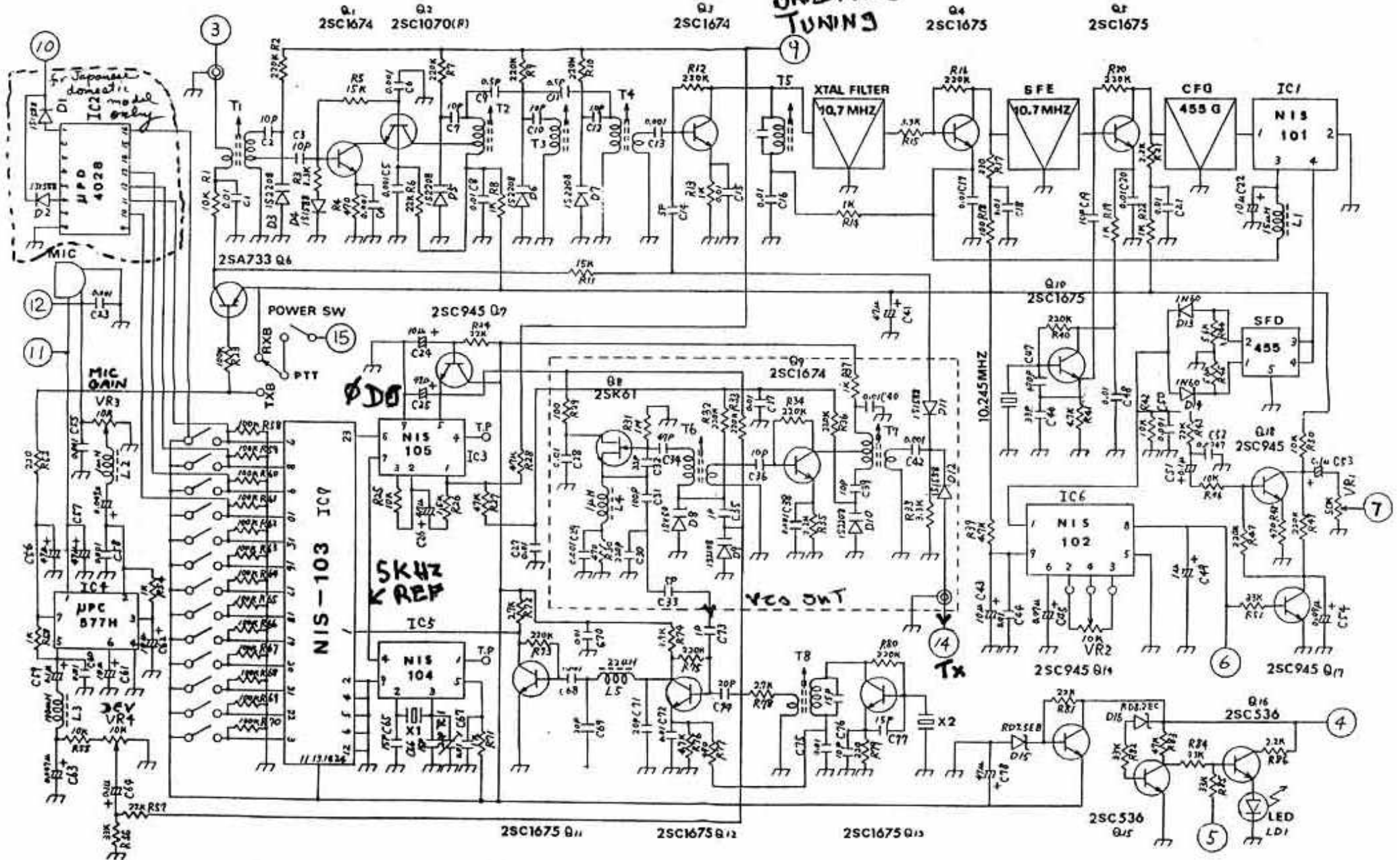

25K61 Q19

J-020-02

25C206 Q21

25C206 Q23

25C206 Q23

25C221 Q24

