

VHF FM TRANSCEIVER **ALR-206T/E**

I N S T R U C T I O N M A N U A L



ALINCO ELECTRONICS INC.

P. O. Box 20009 · Reno, Nevada 89515. U.S.A.
44 Glen Carran Circle · Sparks, Nevada 89431. U.S.A.
Phone (702)359-1414 · Telex 4993999 EGELECTR
Facsimile (702)359-1424

1-1-1 Mishimae, Takatsuki city, Osaka 569. Japan



ALINCO ELECTRONICS INC.

CONTENTS

SPECIFICATIONS.	page 1
Section 1 CONTROL FUNCTIONS.	page 2
Section 2 INSTALLATION.	page 8
Section 3 KEYBOARD OPERATION.	page 10
Section 4 OPERATION.	page 14
Section 5 BLOCK DIAGRAM.	page 15

INTRODUCTION

Congratulation, now you are the owner of one of our many "ALINCO" products.

Your ALR-206T/E has been manufactured and tested very carefully at the factory and will give you satisfactory operation for many years.

ACCESSORIES

Carefully unpack your transceiver and you will find the following accessories included with the transceiver.

- * Microphone (with key pad) x 1
- * D.C. Power Cord x 1
- * Spare fuse (8A) x 1
- * Installing angle joint x 1
- * M5 x 20mm screw x 4
- * M5 x 20mm Mounting screw x 4
- * M5 Nut x 4
- * M5 Flat Washer x 4
- * M5 Spring Washer x 4
- * Screws for Bracket x 4
- * External Speaker Plug x 1

SPECIFICATIONS

■ GENERAL

Frequency Coverage	144.000-147.995MHz (USA) 144.000-145.9875MHz (EU)
Frequency Resolution	5kHz step 800 channels (USA) 12.5kHz step 160 channels (EU)
Antenna Impedance	50 ohms unbalanced
Power Supply Voltage	D.C. 13.8V
Current Drain at 13.8V	Receiving Squelched: Approx. 300mA Transmitting High: 25W Approx. 5A Low: 5W Approx. 2.5A
Dimension	147mm(W) x 51mm(H) x 193mm(D) (5-1/2 inch) (2 inch) (7-1/2 inch)
Weight	Approx. 1.3kgs-2.8 lbs.

■ TRANSMITTER

Output Power	High: 25 WATTS Low: Approx. 5 WATTS
Emission Mode	16F3
Modulation System	Variable reactance frequency Modulation
Max. freq. deviation	±5kHz
Spurious emission	More than 60db below carrier
Microphone	Electret condenser microphone
Operating mode	Simplex Duplex: ±600kHz from receive frequency (Memory channel No. 0 accepts any non-standard TX Offsets) *DTMF encoder included as standard in Model ALR-206T.

■ RECEIVER

Receiving system	Double conversion superheterodyne
Modulation acceptance	16F3
Intermediate frequency	1st: 10.7MHz, 2nd: 455kHz
Sensitivity	Less than -6db for 20db Noise quieting
Selectivity	More than ±7.5kHz at -6db point Less than ±15kHz at -60db point
Audio output power	More than 1.6W
Audio output impedance	8 ohms

1. CONTROL FUNCTION

■ Front Panel

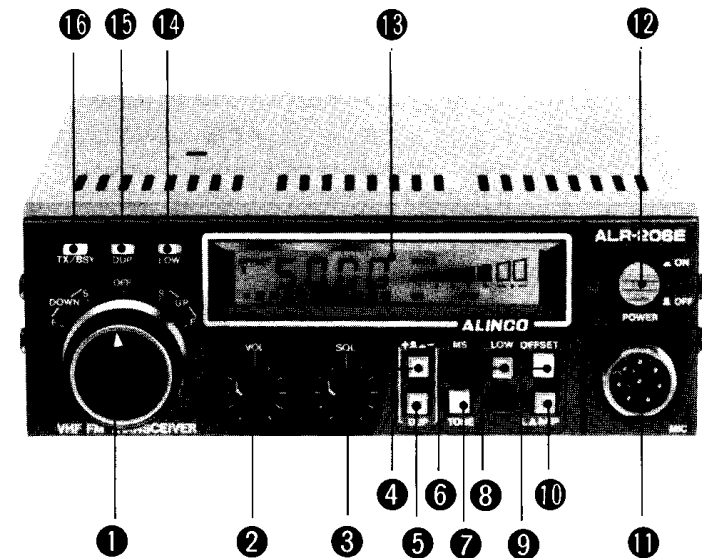

(1) Frequency UP/DOWN Knob

This knob selects the operating frequency. Normally, it indicates the OFF position and the frequency shifts up with 5kHz (ALR-206E: 12.5kHz) step by setting this knob to the UP (S (Slow) or F (Fast)) position and shifts down with 5kHz (12.5kHz) step by setting the knob to the DOWN (S or F) position.

If you lose hold of the knob, it automatically returns to the OFF position. When the knob is set at the S (Slow) position (UP or DOWN), the frequency is scanned at the speed of 1/2 second per channel and beep sound is heard at each increment.

When this knob is set at the F (Fast) position (UP or DOWN), the frequency is scanned at the speed of 1/20 second per channel.

Also, when using the "Program Scan Function", set this knob to the "DOWN-S" position for resuming the scan. (Refer to Section 3: Keyboard Operation)

(2) Volume Control

The audio output level increases by rotating this control clockwise.

(3) Squelch Control

When no signal is present in the receive mode, adjust this control clockwise until the noise threshold is reached.

In scan operation, this control must be set to the threshold point.

(4) TX OFFSET Switch

This switch is used for selecting whether the transmitting frequency is to be 600kHz above (+) or below (-) the receive frequency.

(5) Duplex/Simplex Switch

For repeater operation, set this switch at the Dup (Duplex) position (Subaudible tone unit is activated at the same time. (for ALR-206T only).) and for simplex operation, set this switch at the Simp (Simplex) position, making (4): TX OFFSET Switch non-functional.

*Subaudible tone unit (For ALR-206T only) : For setting the built-in DIP switch, refer to the chart below.

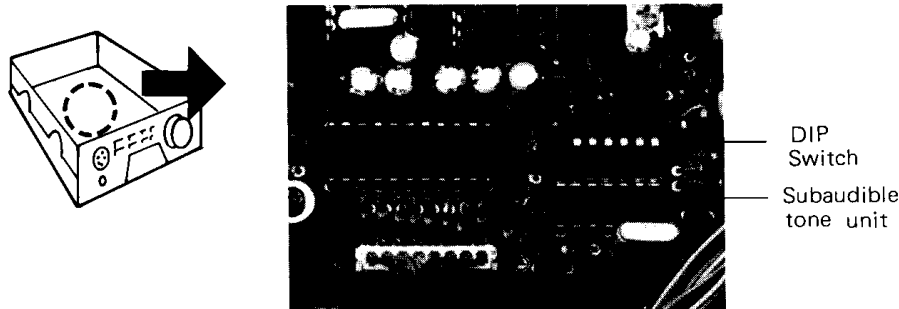

Subaudible Tone Chart (ON = 1)

Freq. (Hz)	P1	P2	P3	P4	P5	P6
67.0	1					
71.9		1				
74.4	1	1				
77.0			1			
79.7	1		1			
82.5		1	1			
85.4	1	1	1			
88.5				1		
91.5	1			1		
94.8		1		1		
97.4	1	1		1		
100.0			1	1		
103.5	1		1	1		
107.2		1	1	1		
110.9	1	1	1	1		
114.8					1	
118.8	1				1	
123.0		1			1	
127.3	1	1			1	
131.8			1		1	

Freq. (Hz)	P1	P2	P3	P4	P5	P6
136.5	1		1		1	
141.3		1	1		1	
146.2	1	1	1		1	
151.4				1	1	
156.7	1			1	1	
162.2		1		1	1	
167.9	1	1		1	1	
173.8			1	1	1	
179.9	1		1	1	1	
186.2		1	1	1	1	
192.8	1	1	1	1	1	
203.5						1
210.7	1					1
218.1		1				1
225.7	1	1				1
233.6			1			1
241.8	1		1			1
250.3		1	1			1

(6) Memory Scan Switch

By pressing this switch, scan starts and memorized channel numbers and frequencies are displayed.

(Scan speed is fixed: 1/2 second per channel) and the scan stops at a channel where the signal is present and resumes 2 seconds later after the signal goes away. To resume the scan while stopped on a signal, press the MS switch again.

To clear this function, press C key or P.T.T. switch of the microphone.

(7) Tone-Burst Button (for ALR-206E only)

This switch activates a 1750Hz tone-burst generator for initial access of the repeater. Depress this switch for a required period and carrier with a 1750Hz tone will be transmitted.

HI/LOW Switch

This switch is used to set output power to HIGH and LOW.

In the HIGH (out) position, the output power is 25W.

In the LOW (locked-in) position, the output power is approx. 5W.

(9) Offset CH Switch (for non-standard repeater offsets)

When this switch is set in the locked-in position, the frequency memorized in channel No. 0 is transmitted by pressing the P.T.T. Switch.

Subaudible tone unit is activated at the same time.

(10) LAMP Switch

When this switch is set in the locked-in position, the LCD display panel is lit up.

(11) MIC (Microphone) Jack

An electret condenser microphone with keypad is supplied with the transceiver.

Plug it into this 8-pin jack.

CIRCUIT DIAGRAM

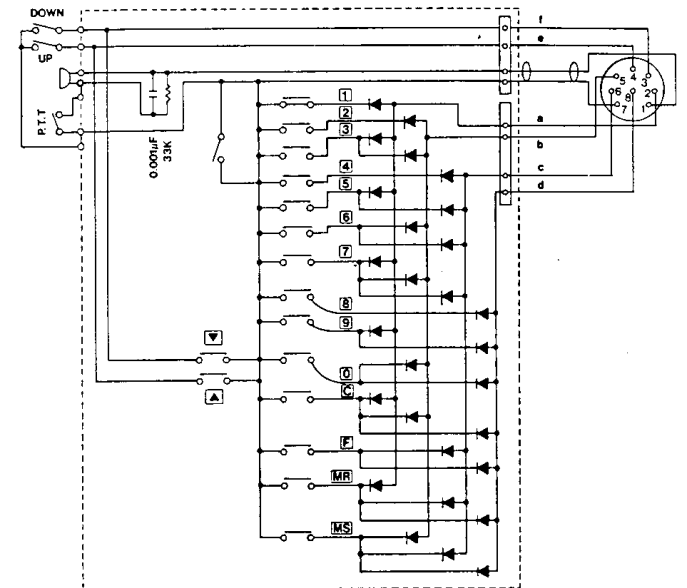

(12) Power ON/OFF Switch

(13) LCD (Display)

This LCD panel indicates the operating frequency, signal strength, power output or some other functions as shown in the drawing below.

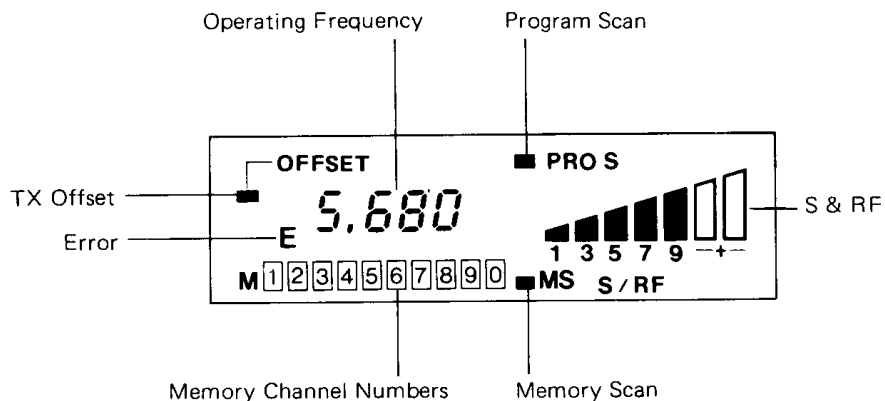

(14) LOW Indicator

This LED is lit when the 'LOW' Power Switch is set in the 'ON' (locked-in) position.

(15) DUP Indicator

This LED will indicate 'DUPLEX' (repeater) mode.

(16) TX/BSY Indicator

A red LED is lit in the transmit mode and, in the receive mode, a green LED is lit when the signal is received or whenever the squelch is open.

■ REAR PANEL

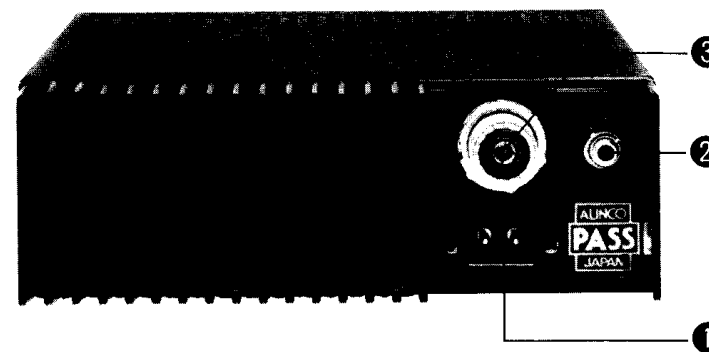

(1) Power Connector

Connect the supplied power cable to this connector.

(2) External Speaker Jack

When an external speaker (Imp.: 8 Ohms) is used, connect it to this jack.

(3) Antenna Connector

Used to connect the antenna to the set.
Use a PL259 antenna-plug with 50 Ohms impedance.

■ MICROPHONE

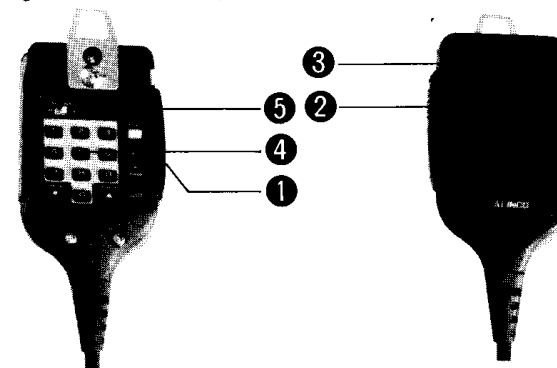

(1) P.T.T. Switch (Press-to-talk switch)

For transmission, press this switch and speak into the microphone.

(2) DOWN Switch

By pressing this switch, the operating frequency shifts down with 5kHz step. (ALR-206E: 12.5kHz step)
When this switch is kept depressed for more than one second, the frequency is manually scanned.

2. INSTALLATION

(3) ▲ UP Switch

By pressing this switch, the operating frequency shifts up with 5kHz step. (12.5kHz)
When this switch is kept depressed for more than one second, the frequency is manually scanned.

(4) Key Board Switches (Also refer to Key Board Operation)

① – ⑩: Numerical keys

Used to set operation frequencies and channel numbers to be memorized.

ⓐ: Clear/Stop key

Press this key and the entered digits are canceled and the lowest band edge frequency is recalled.

When this key is pressed during Memory or Program scan, operating frequency or memory channel stops on the displayed one.

ⓑ: Function key

Used to store and erase the memory with the ⓂⓇ key, to preset the scan width and scan step for program scan with the ▲ key, and to Operate program scan with the ▼ key.

ⓂⓇ: (Memory/Memory Recall) key

Used to 1. STORE and 2. ERASE the memory with the ⓑ key and desired set key ① – ⑩ and to 3. RECALL memory with desired set key ① – ⑩.

1: Please refer to: Memorizing Frequency

2: " : Erasing Memory

3: " : Recalling Memorized Frequency

ⓂⓈ: Memory Scan key

By pressing this key, scan starts and memorized channel numbers and frequencies are displayed (Scan speed is fixed: 1/2 second per channel) and the scan stops at a channel where signal is present and resumes 2 seconds later after the signal goes away. To resume the scan while stopped on a signal, press the ⓂⓈ key.

▲ (Up/Scan. W) key

By pressing this key, the operating frequency shifts up with 5kHz. step. (ALR-206E: 12.5kHz step)

When this key is kept depressed for more than 1 second, the frequency is manually scanned.

This key is also used with the ⓑ key to set the scan width and scan step for program scanning.

The scan step must be 5kHz. (12.5kHz) or its multiples. (5.10 . . . 20.25kHz.) (12.5, 25, 37.5, 50kHz)

▼ (Down/Prog. S) key

By pressing this key, the operating frequency shifts down with 5kHz. step. (12.5kHz)
When this key is kept depressed for more than 1 second, the frequency is manually scanned.

This key is also used with the ⓑ key for program scan operation.

Scan width and Scan step must be preset.

(5) KEY LOCK Switch

When this switch is set in the "ON" position, the 16 keys on the keyboard will not function.

■ MOBILE INSTALLATION

(1) Location

The transceiver may be installed in any position in your car, where the controls and microphone are easily accessible and safe operation of the vehicle or the performance of the set will not be interfered with.

Refer to the diagrams for installation of the Mounting Bracket.:

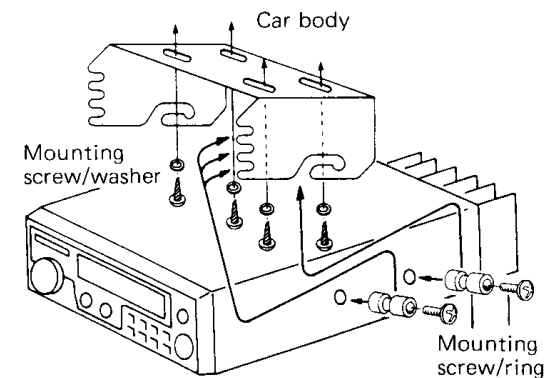
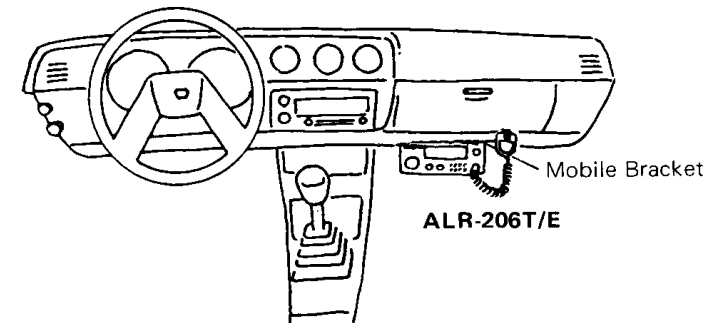

3. KEYBOARD OPERATION

(2) Power Requirements

The transceiver can be operated from any regulated 12 or 13.8V negative ground source. For mobile use, power connections should be made directly to the battery to minimize the possible ignition noise pickup.

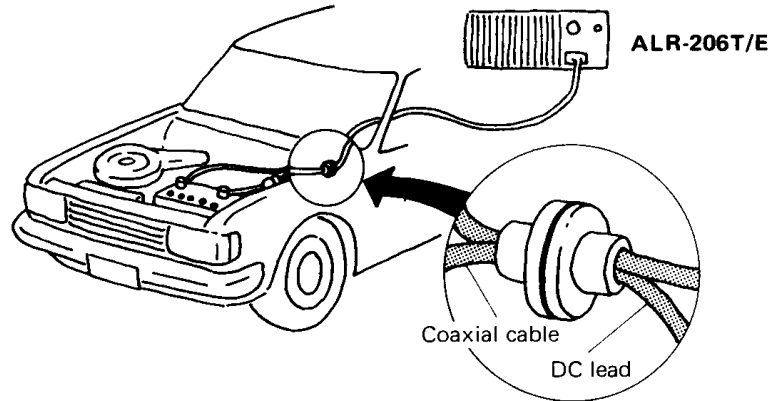

■ BASE STATION INSTALLATION

For fixed base operation, a 13.8V D.C. Power Supply capable of providing at least 8A continuously is required. The "ALINCO" EPS-110M D.C. Power Supply is suitable for this purpose. Connect the red lead of the power cable to the Positive (+) terminal, and the black lead to the Negative (-) terminal of EPS-110M.

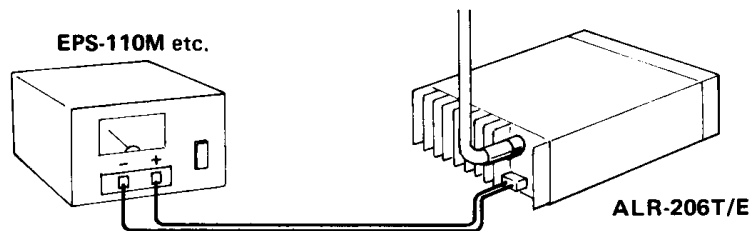

The ALR-206T/E employs a 16 key channel selection system. These instructions cover the basic operation of the keyboard. It is also advisable to refer Section 4 "Operation".

■ Channel Selection

Frequencies are entered in 4 digits so, when entering 145.445, press keys **5** **4** **4** and **5** in that order. (ALR-206E: When entering 145.4375MHz, Press **5** **4** **3** in 3 digits. In this case, 0.5kHz digit is not displayed on LCD panel.)

(When entering frequencies, please confirm that the frequencies are within the coverage of the Transceiver, otherwise,

E (ERROR) Symbol is displayed on LCD.)

If the key setting is found to be incorrect after pressing 4 keys, press the correct keys once again.

To correct the setting before all the 4 keys are pressed, press the **C** key and then press the correct set keys.

■ To Shift frequency, proceed

Press the keys as outlined above, or press the **▲** or **▼** key.

The frequency shifts up or down by 5kHz. (ALR-206E: 12.5kHz) at each press of the **▲** or **▼** key; frequency is scanned when either key is kept depressed for more than one second.

(for ALR-206T)

For example

(for ALR-206E)

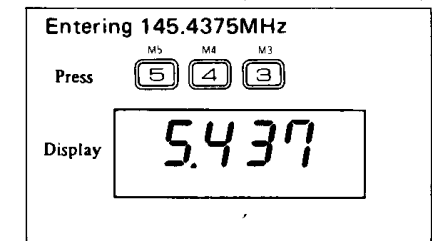
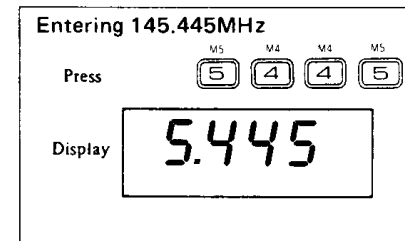

Shifting Frequency

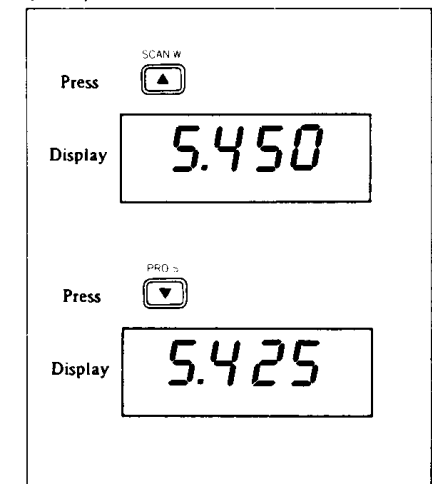
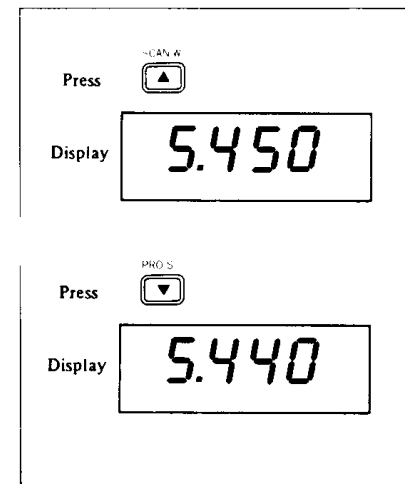

■ Memorizing Frequency

First display the frequency to be memorized by pressing Set keys then press the **F** **MR** keys.

All memorized channel numbers are displayed on LCD.

Next, press a Set key **1** - **0** to select a storage channel.

A lower-key beep sound is heard to confirm the frequency has been memorized in that channel.

For example:

To memorize 145.805MHz. into channel No. 4.

(1) With the frequency 5.805 displayed, press the **F** **MR** keys.

Only memorized channel addresses are displayed on the LCD.

(2) Press the **4** key

A lower-key beep is heard confirming 145.805MHz. has been memorized into channel **4**.

Memorizing Frequency

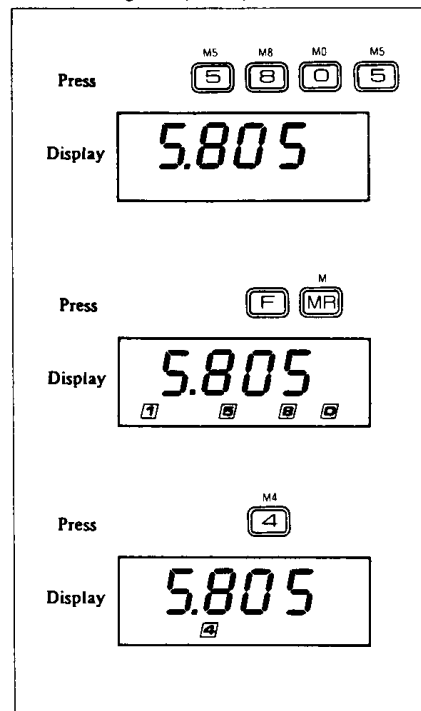

Recalling Memorized Frequency

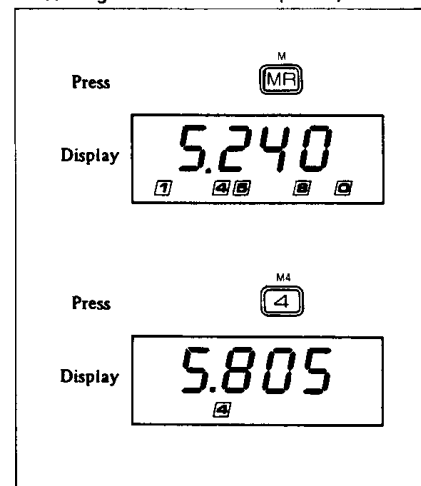

■ Recalling Memorized Frequency

Press the **MR** key and all memorized channel addresses are displayed then press a Set key **1** - **0** for the desired channel.

The channel number and the frequency, memorized in that channel are displayed on LCD.

For example:

To recall the frequency memorized in 4 channel.

(1) Press the **MR** key

(2) Among the displayed channel numbers, press the **4** key.

(3) The channel number **4** and the memorized frequency 145.805 in that channel are displayed on LCD.

■ Erasing Memory

(1) To erase all memories, push the RE SET Switch.

(2) To erase each memory, press **F** **MR** **F**, then the channel number to be erased.

The ALR-206T/E will scan only the occupied channels, so the scan speed will be faster by erasing unwanted channels.

Erasing Memory

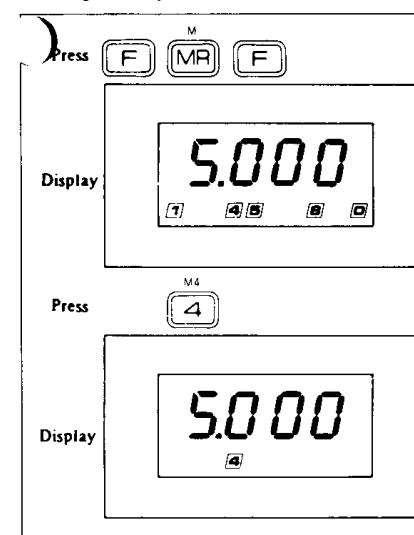

■ Memory Scan

Set the SQUELCH control knob to the threshold level and then push the **MS** key.

The scan starts and memorized channel numbers and frequencies are displayed (scan speed is fixed: 1/2 second per channel) and the scan stops at a channel where signal is present and resumes 2 seconds later after the signal goes away.

If you want to resume the scan when the scan stops on a signal, press the **MS** key again, and the displayed memorized channel changes one increment, to the upper channel.

To clear the scan function, press the **C** key and the scan stops on the memory

channel displayed.

Scan function is also cleared when you push the P.T.T. switch.

Memory Scan

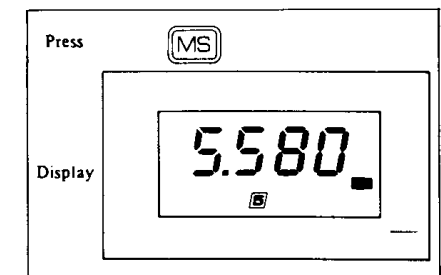

■ Program Scan

This is to scan between the two desired frequencies by setting the scan width and scan step beforehand.

A. Setting the Scan Width and Scan Step.

First, enter the low edge frequency and then press **F** - **▲** keys. Next, by pressing the digit key or **▲** button, enter the next higher frequency with the desired channel step (5, 10, 15 - 25kHz.) (ALR-206E: 12.5, 25, 37.5, 50kHz.) and then press **F** - **▲** keys.

Finally, enter the upper edge frequency and then press **F** - **▲** keys. A lower-key beep sound is heard confirming scan programming is complete.

Note: If the key setting is incorrect, a lower-key beep will not sound.

In this case, press the **C** key and enter the correct keys.

For example:

Low edge frequency: 144.000MHz.
Frequency step: 15kHz.

High edge frequency: 145.995MHz.

(1) Set frequency: 4.000, then press **F** - **▲** keys

(2) Set frequency: 4.015, then press **F** - **▲** keys

(3) Set frequency: 5.995, then press **F** - **▲** keys

(4) Set the SQUELCH Control to the threshold level and then push the **F** - **▼** keys.

4. OPERATION

■ Program Scan Operation

1. The scan starts from the low edge frequency and when the scanning frequency reaches the high edge frequency, it automatically returns to the low edge frequency and continues scanning to provide endless scanning operation.
2. The scan stops at a channel where signal is present and resumes 2

seconds later after the signal goes away.

If you want to resume the scan when the scan stops on a signal, press the \downarrow key again.

3. To clear the scan function, press the \square key.

Scan function is also cleared when you push the P.T.T. switch.

Program Scan

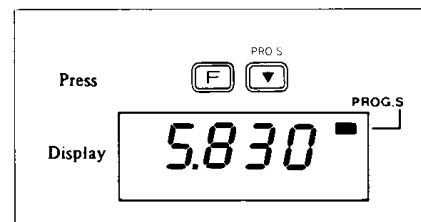
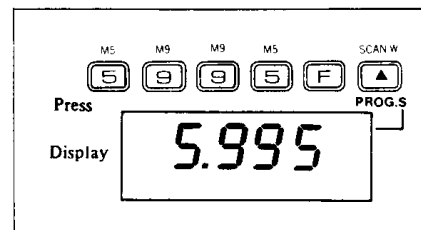
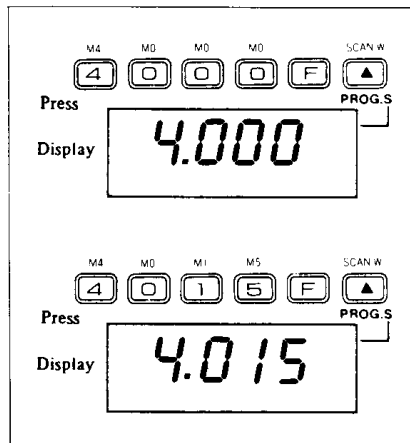

■ RECEPTION

1. Push the Power Switch to "ON".
2. A frequency will be displayed on LCD Panel.
3. Turn the SQL (Squelch Control) completely counterclockwise and VOL (Volume Control) clockwise slowly to a comfortable level.
4. Select the desired frequency by turning the main Knob or pushing keys on the Keyboard of the Microphone.
5. If no signal can be heard but only noise, turn the SQL clockwise until the noise from the speaker stops and set it just below this threshold.

■ TRANSMISSION

1. For SIMPLEX operation, set the DUP/SIMP (DUPLICATE/SIMPLEX) Switch to the SIMP Position.
2. For DUPLEX (Repeater) operation, set the DUP/SIMP Switch to the "DUP" position and select the TX OFFSET frequency by the \pm (+: +600kHz., -: -600kHz. from the receive frequency.)
3. Select either LOW POWER or HIGH POWER.
4. Depress the P.T.T. (Press-To-Talk) switch and speak into the microphone with your normal speech level for the proper microphone level. The On-AIR indicator LED (red) will be lit.

DIAGRAM

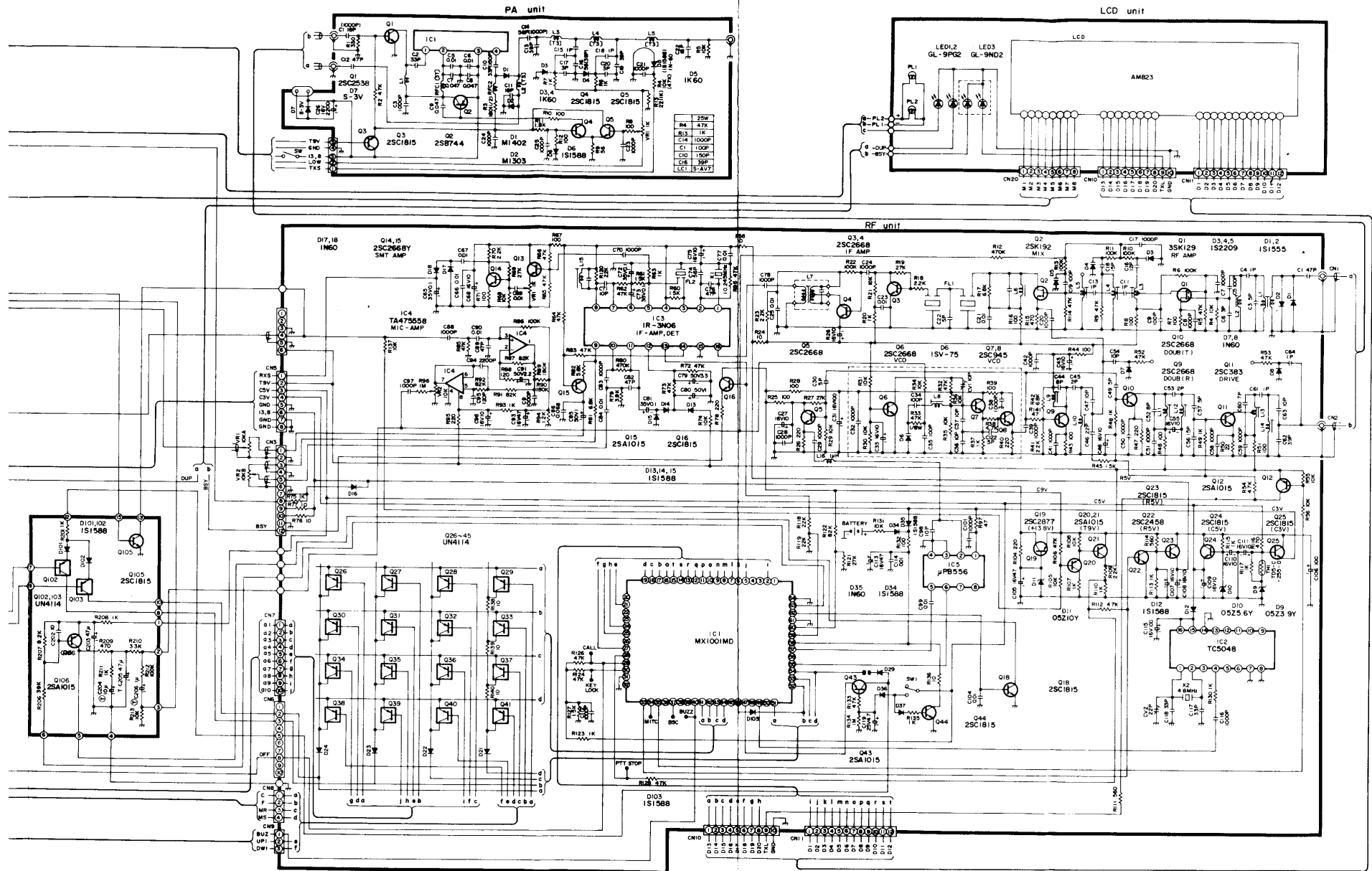

ALINCO ELECTRONICS INC.

Some components subject to change for an improvement without notice.

ALR-206T SCHEMATIC DIAGRAM

CONTROL unit

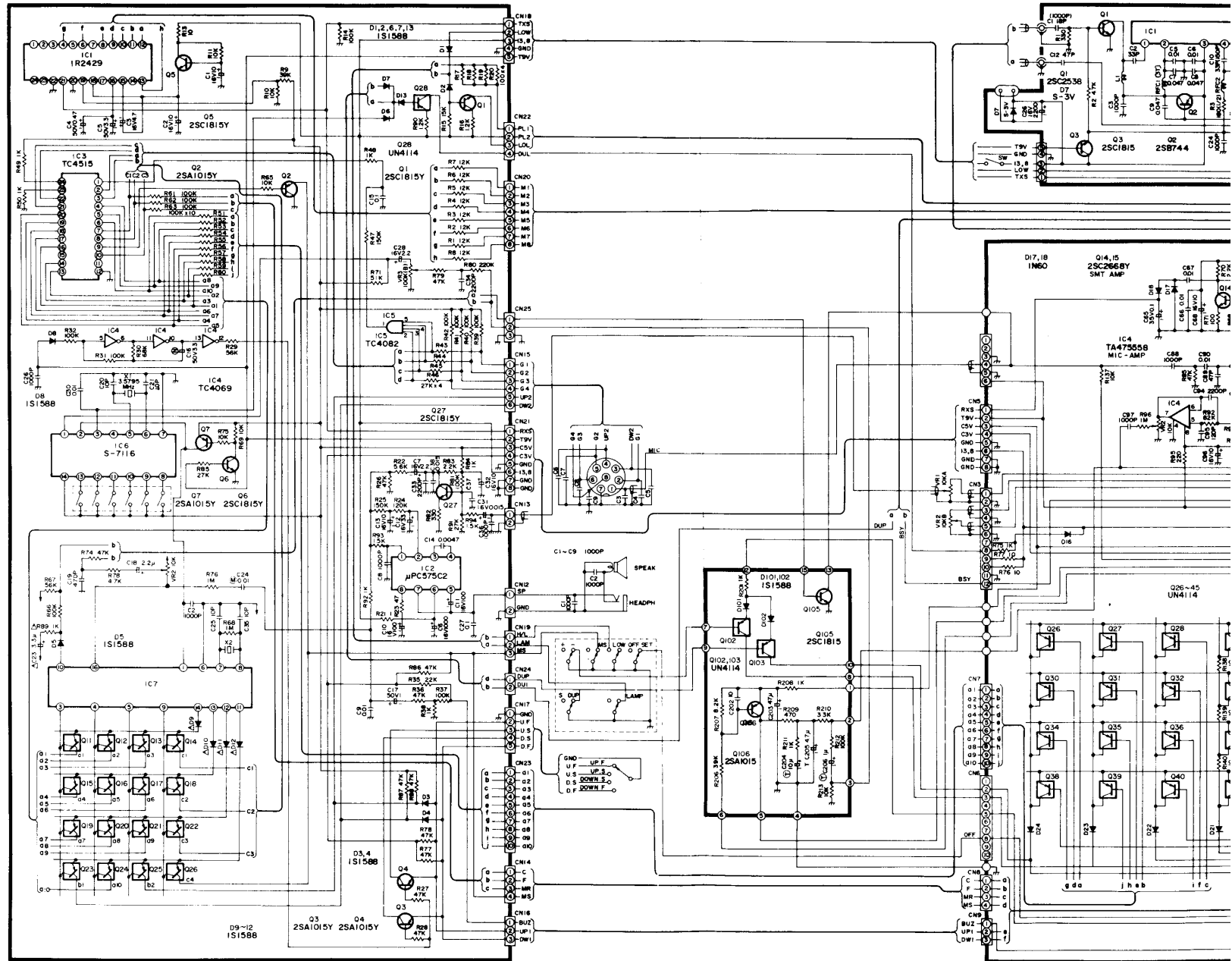

D9-12
1S1588

Q3
25A1015Y 25A1015Y

