



Model No: 3419

Model No:

Drawing No:

Customer :

M-795 Power

Rev,Date:

# M-795 Power

# Service Manual

Created by:	Approved by:	Rev.No:
For Stage:	Release Date:	Page: 1 / 55



Model No: 3419	Title	Drawing No:
Customer :	M-795 Power	Rev,Date:

## Table of Contents

	Page
Specifications	3
Block Diagram	14
Schematic Diagram	15
Printed Circuit Board	25
Channel Frequency Charts	26
Test and Alignment Procedure	4
Parts List	38
Semiconductor Voltage Chart	48
Semiconductor Lead Assignment and Block Diagram	49
Exploded View Part list	54
Exploded View	55

Created by:	Approved by:	Rev.No:
For Stage:	Release Date:	<b>Page:</b> 2 / 55



Model No: 3419	Title	Drawing No:
Customer :	M-795 Power	Rev,Date:

## SPECIFICATIONS

### 1. GENERAL

Channels..... 400 Ch AM/FM 4W  
Frequency Range..... ..25.615 to 30.105 MHz  
FrequencyControl.....PLL  
Operating Temperature Range.....-10° / +55°C  
DC Input Voltage.....13.2 V DC ±15%  
Size.....180(L) X 35(H) X 140(D) mm  
Weight.....0.850 kg

### 2. RECEIVER

Receiving System.....Dual Conversion Super Heterodyne  
Intermediate Frequency.....1<sup>st</sup> IF: 10.695 MHz, 2<sup>nd</sup> IF: 455 MHZ  
Sensitivity.....0.5 µV for 20 db SINAD in FM mode  
Audio Distortion.....Less Than 8% @ 1 KHz  
ImageRejection.....65 dB  
Adjacent ChannelRejection.....65 dB  
Signal/ Noise Ratio.....45 dB  
Current Drain at standby.....325 mA

### 3. TRANSMITTER

Output Power.....4W @ 13.2 V DC  
Modulation.....FM: 1.8 KHz ±0.2 KHz  
Frequency response.....From 400 Hz to 2.5 KHz  
Output impedance.....RF 50 ohm Unbalance  
Signal/ Noise Ratio.....40 dB MIN  
Current Drain.....1300 mA

Created by:	Approved by:	Rev.No:
For Stage:	Release Date:	Page: 3 / 55



Model No: 3419

Model No:

Drawing No:

Customer :

M-795 Power

Rev,Date:

## OPERATION INSTRUCTIONS

Having properly installed your batteries and hooked-up the antenna, you are now ready to operate your radio for optimum reception and voice transmission.

Turn the power "ON" with ON/OFF switch.

Set the desired channel.

Adjust the squelch control knob to reduce any undesirable background noise when no signal is being received. To do this, select a channel where no signal are present, or wait until signals cease on your channel. Then, rotate the squelch control knob clockwise to a point where the background noise disappears.

**Note:** When the squelch is set properly, the speaker will remain quiet until a signal is received. In order to receive weak signals, do not set the squelch too high.

Adjust the volume to the desired listening level.

### To Transmit

Press and hold the push-to-talk button. Speak slowly and clearly in a normal voice two to three inches from the microphone. A built-in modulation control circuit will automatically adjust the microphone input level. There is no need to speak loudly.

### To Receive

Release the push-to-talk button.

Created by:	Approved by:	Rev.No:
For Stage:	Release Date:	Page: 4 / 55



Model No: 3419

Model No:

Drawing No:

Customer :

M-795 Power

Rev,Date:

## THEORY OF OPERATIONS

### TRANSMITTER

#### A. RF Amplification

The output of double AMP Q301 is fed through tuning IFT L301 and L302 to the base of pre driver AMP Q302. The output is then supplied through tuning circuit L303 to RF driver AMP Q303. The output of Q303 is supplied with tuning circuit L304 and C317,C315,C21 and goes to the base of final RF AMP Q304. The output of Q304 is supplied to the antenna through L-C tuning circuit.

#### B. Circuit for Suppression of Spurious Radiation

The tuning circuit between the output of final AMP Q304 and antenna, 4-stage "PHI" network L308, C324, C1, C327, L311, C337, C333, L312, C328, C334, C338, L313 serves as a spurious radiation suppressor . This network also serves to match the impedance between TX power AMP Q304 and the antenna.

#### C. Circuit for Limiting Power

After finished all alignment, the constant voltage supply circuit limits the available power 4 W or slightly less. RV1 and corresponding three transistors control supply voltage of RF amplifier and other circuits.

Tune all the trimmer parts for maximum indication of RF power meter and adjust RV1 to make 4 w indication of RF power meter.

The tuning is adjusted so that the actual power is from 3.8 to 4.0 W. There are no other additional controls for adjusting the TX output power.

#### D. Modulation Control

##### a. FM

The mic input is fed to mic audio amplifier IC KIA324 which drives modulation varicap diode D403 in the VCO circuit. RV401 limits the incoming modulation audio levels to inhibit over modulation. While reading the modulation factor on the modulation analyzing equipment, adjust RV401 shall not exceed  $\pm 1.8$  KHz/Dev. After 20 dB up from 1.25 KHz/1.2 KHz/Dev. Audio level

##### b. AM

Modulation signals are filtered with RC network and goes to the audio power AMP IC IC103 to make nominal signal level to achieve wanted modulation. To control incoming audio signal, diode D203 and corresponding ALC circuit limits the modulation shall not exceed  $\pm 80\%$  adjust RV201  $\pm 80\%$  modulation under 1.0 KHz AF 60% mod plus 20 dB of audio signal.

Created by:	Approved by:	Rev.No:
For Stage:	Release Date:	Page: 5 / 55



Model No: 3419	Model No:	Drawing No:
Customer :	M-795 Power	Rev,Date:

### E. Receiver

CB receiver is dual conversion super-heterodyne type with the first IF 10.695 MHz and second IF 455 KHz. Receiver is separated two blocks, 1<sup>st</sup> IF section and 2<sup>nd</sup> IF section.

The PLL synthesizer supplies first local frequency 16.270 ~ 16.710 MHz.(for EU) and 16.90625 MHz ~ 17.29625 MHz (for UK) With the provided first local frequencies Q105,Q106 mixes the incoming RF signal to generate first IF signal. Mixed signals were filtered with the XF101 (10.695 MHz) crystal filter and other tuning circuits. Output signal of mixer is filtered with CF101 (455 KHz ceramic filter). The 455 KHz signal from the 2<sup>nd</sup> IF filter was amplified and limits internally. After amplification the signals fed the quadrature detector loop L104. Then we can see the recovered audio signals on Pin 11 for FM of IC102. With the amplitude of recovered signals, Q112 serves as an audio amplifier. For AM signal Will be pass filter CF101 and induced to Q116, Q117 respective and detected to voice signal by D111.

### TROUBLESHOOTING HINTS

<i>Symptom</i>	<b>Probable Cause</b>	<b>Remedy</b>
Unit does not work at all	<ul style="list-style-type: none"> <li>• Defective power switch VR102.</li> <li>• Blown fuse.</li> <li>• Broken DC power cord.</li> <li>• Defective IC101.</li> </ul>	<ul style="list-style-type: none"> <li>• Replace</li> <li>• Replace</li> <li>• Replace</li> <li>• Replace</li> </ul>
No output from speaker at all	<ul style="list-style-type: none"> <li>• Defective external speaker jack.</li> <li>• Poor connection on microphone connector</li> <li>• Defective push switch on microphone.</li> <li>• Defective internal speaker.</li> <li>• Defective VR102, IC103 other components.</li> </ul>	<ul style="list-style-type: none"> <li>• Repair or replace</li> <li>• Repair or replace</li> <li>• Repair or replace</li> <li>• Replace</li> <li>• Replace the defective components.</li> </ul>
No noise on speaker	<ul style="list-style-type: none"> <li>• Measure all the voltage of IC102 with voltage chart</li> <li>• Defective squelch circuit components (RV102, VR1, IC102)</li> </ul>	<ul style="list-style-type: none"> <li>• Replace</li> <li>• Replace</li> </ul>
Squelch does not work	<ul style="list-style-type: none"> <li>• Defective VR1, RV2, IC2.</li> </ul>	<ul style="list-style-type: none"> <li>• Replace the defective components.</li> <li>• Re-adjust</li> </ul>

Created by:	Approved by:	Rev.No:
For Stage:	Release Date:	<b>Page:</b> 6 / 55



Model No: 3419

Model No:

Drawing No:

Customer :

M-795 Power

Rev,Date:

No modulation	<ul style="list-style-type: none"><li>• Defective microphone.</li><li>• Poor audio output and defective modulation microphone amplifier components (IC103).</li><li>• Defective microphone connector components.</li><li>• Defective ALC circuit D413, D414.</li></ul>	<ul style="list-style-type: none"><li>• Replace</li><li>• Replace the defective components.</li> <li>• Replace</li><li>• Replace the defective components.</li></ul>
LCD meter does not work	<ul style="list-style-type: none"><li>• Defective D5.D3</li><li>• Defective IC101.</li><li>• Defective RV101.RV202</li></ul>	<ul style="list-style-type: none"><li>• Replace</li><li>• Replace</li><li>• Replace</li></ul>
LCD display does not work	<ul style="list-style-type: none"><li>• Defective RED wire fuse.</li><li>• Defective IC101, Q414.</li></ul>	<ul style="list-style-type: none"><li>• Replace</li><li>• Replace</li></ul>
Channel selector does not work	<ul style="list-style-type: none"><li>• Defective IC101, SW105.</li></ul>	<ul style="list-style-type: none"><li>• Replace</li></ul>
EMG CH9.19 does not work	<ul style="list-style-type: none"><li>• Defective EMG SW.</li><li>• Defective IC101.</li></ul>	<ul style="list-style-type: none"><li>• Replace</li><li>• Replace</li></ul>

Created by:

Approved by:

Rev.No:

For Stage:

Release Date:

Page: 7 / 55

## ALIGNMENT PROCEDURE

Step	Setting	Connection	Adjuster	Adjust for
1	Frequency adjustment MIC : Receive Volume : optional Squelch : optional CH selector : 19 EU CH9 : off	Frequency counter to dummy load (Figure 1).	CT201	27.185MHz±300Hz
2	VCO Voltage adjustment MIC : Receive Volume : optional Squelch : optional CH selector : 1A CH9 : OFF	Connect DC voltmeter between R406, C411 and GND. (Figure 2).	L501	1V at TX.

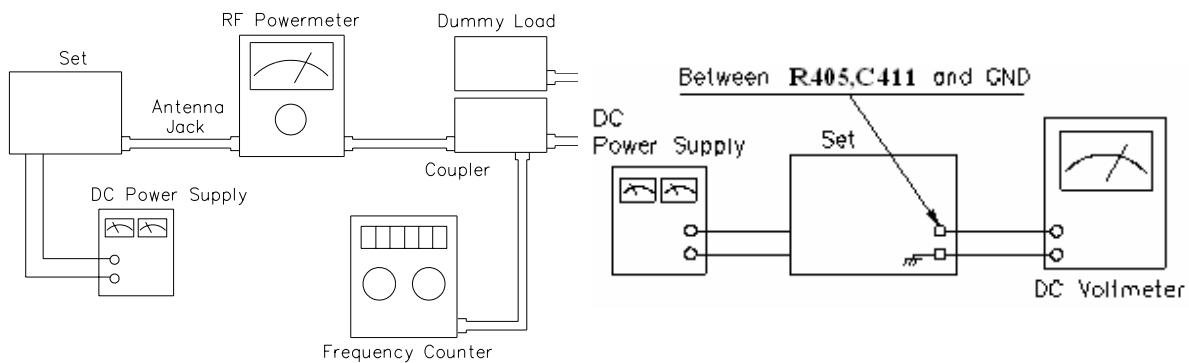

Figure 1

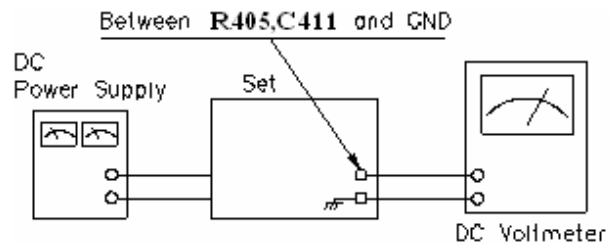

Figure 2





Model No: 3419	Model No:	Drawing No:
Customer :	M-795 Power	Rev,Date:

## TRANSMITTER SECTION

### Test Equipment Required

- RF power meter (RF SSVM)
- 50 ohms dummy load (non-inductive)
- RF attenuator (50 ohms non-inductive)
- Oscilloscope
- Audio generator
- DC power supply (13.2 volt, 3 amp)
- Spectrum analyzer
- Frequency counter
- Coupler

### ALIGNMENT PROCEDURE

Step	Setting	Connection	Adjuster	Adjust for
1	RF power stage MIC : Transmit Volume : optional Squelch : optional CH : selector : 19 CH9 : OFF	Connect dummy load and RF power meter to the EXT-ANT jack on the set (Figure 3).	L301 L302 L303	Maximum indication on the power meter (4 watts). If indication is not in 4 watts range, adjust L301, L302, L303.
2	Second harmonic check MIC : Transmit Volume : optional Squelch : optional CH : selector : 19 CH9 : OFF	Connect RF power meter With dummy load to spectrum analyzer through coupler /-40 dB Attenuator to EXT-ANT jack on the set (Figure 4).		At no modulation, compare the level o fundamental frequency to the level of harmonic frequency. Suppression of the 2 <sup>nd</sup> harmonic frequency level must be lower than -60 dB. Check for the other channels.
3	Frequency check MIC : Transmit Volume : optional Squelch : optional CH : selector : 19 CH9 : OFF	Connect dummy load and frequency counter though coupler to RF powermeter. Connect RF powermeter to EXT-ANT jack on the set (Figure 5).	CT201	Be sure that the indication of the transmitter frequency is 27.185MHz±300Hz on the frequency counter.

Created by:	Approved by:	Rev.No:
For Stage:	Release Date:	Page: 9 / 55

Model No: 3419	Model No: M-795 Power	Drawing No:
Customer :		Rev,Date:

4	TX power level adjustment Volume : optional Squelch : optional CH : selector : 1 CH9 : OFF	Connect dummy load and oscilloscope through Coupler to RF powermeter connect audio generator to microphone jack (Figure 6).	RV202	Adjust until the 5 <sup>th</sup> bar appears on the channel display LCD.
---	--	---	-------	--

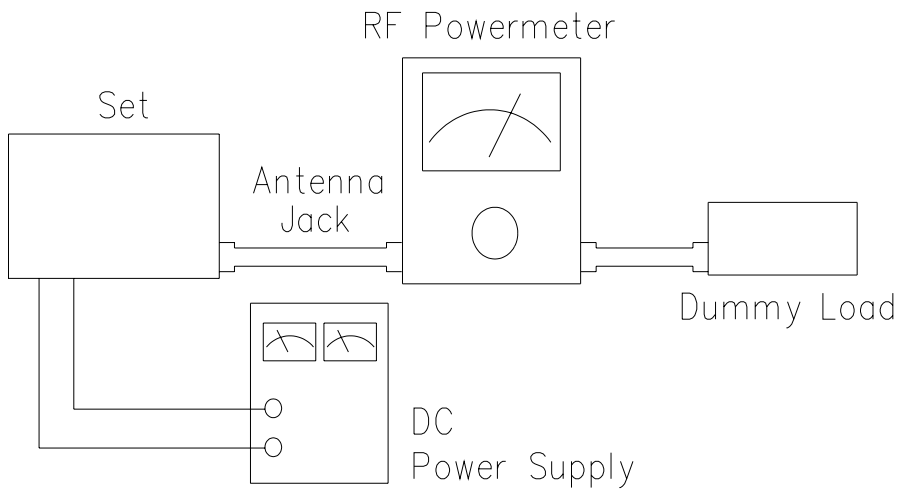

Figure 3

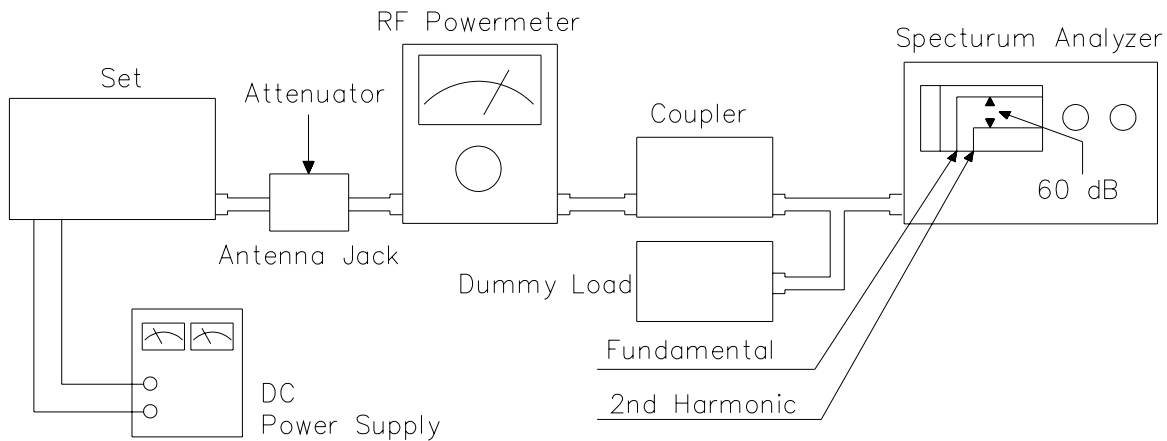

Figure 4

## RECEIVER SECTION

### Test Equipment Required

- RF Signal generator (RFSG)
- SSVM
- Distortion meter
- DC power supply

### ALIGNMENT PROCEDURE

Step	Setting	Connection	Adjuster	Adjust for
1	Audio output adjustment MIC : Receive Volume : Fully clockwise Squelch: Turn to- Counter clockwise CH selector : 19 RF gain : Fully clockwise CH9 : OFF RFSG:27.185 MHz,1kHz 1 $\mu$ V , 1.2 K Dev.	Connect RF signal generator to EXT-ANT jack. Connect SSVM and distortion meter with 8 ohm dummy load (Figure 7).	L101 L102 L103 L104 L106 L401 L402 L403	Maximum indication on SSVM. Reduce output from RFSG until the audio output becomes about 500mW (2V).

Model No: 3419	Model No:	Drawing No:
Customer :	M-795 Power	Rev,Date:

2	Squelch adjustment MIC : Receive Volume : 50mW (2V) Squelch : Clockwise CH selector : 19 RFSG:27.185MHz, 1kHz 1mV, 1.2K DEV.	Connect RF signal generator to EXT-ANT Jack. Connect SSVM and distortion meter to EXT speaker jack with 8 ohm dummy load (Figure 7).	RV1	Adjust until the audio output appears.
3	RF signal meter adjustment MIC : Receive Volume : 500mW (2V) Squelch : Fully counter Clockwise RFSG: 27.185 MHz, 1kHz, 1μV, 1.2K Dev.	Connect RF signal generator to EXT-ANT Jack. Connect SSVM and distortion meter to EXT speaker jack with 8 ohm dummy load (Figure 7).	RV101	Adjust until the 3 <sup>rd</sup> LED on the S/RF meter lights up.

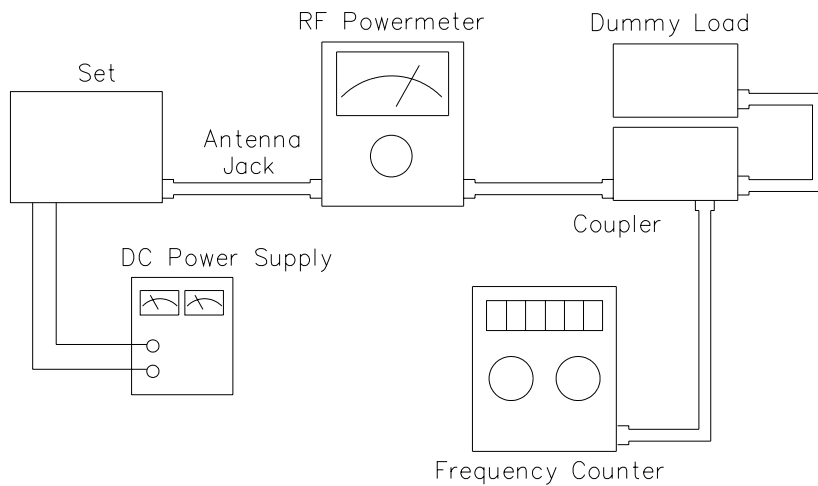

Figure 5

Created by:	Approved by:	Rev.No:
For Stage:	Release Date:	Page: 12 / 55

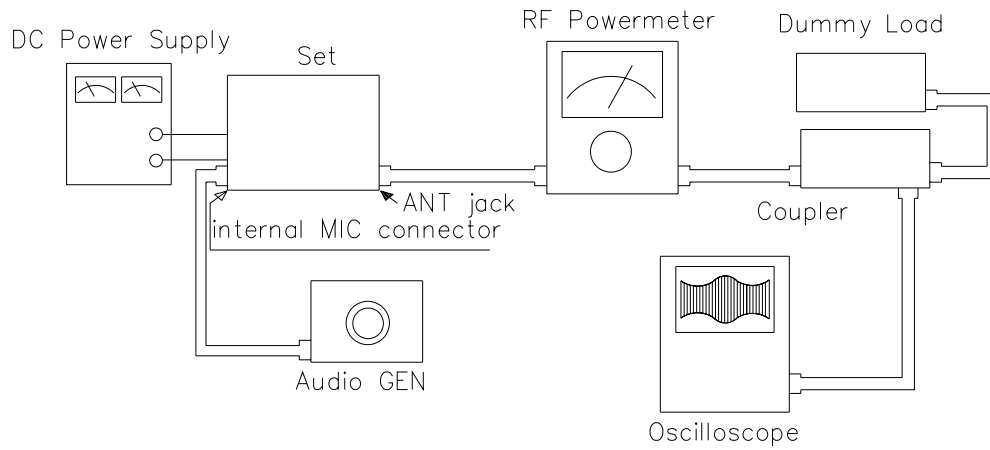

Figure 6

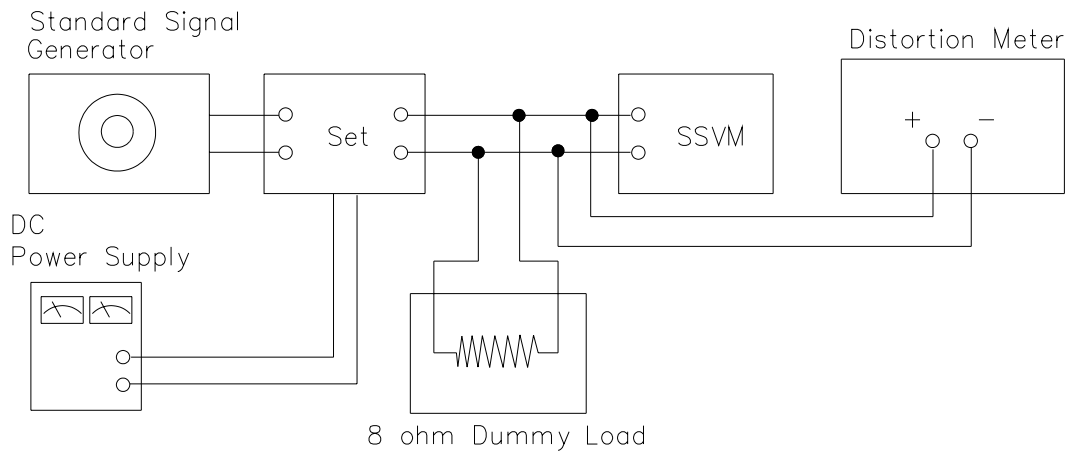
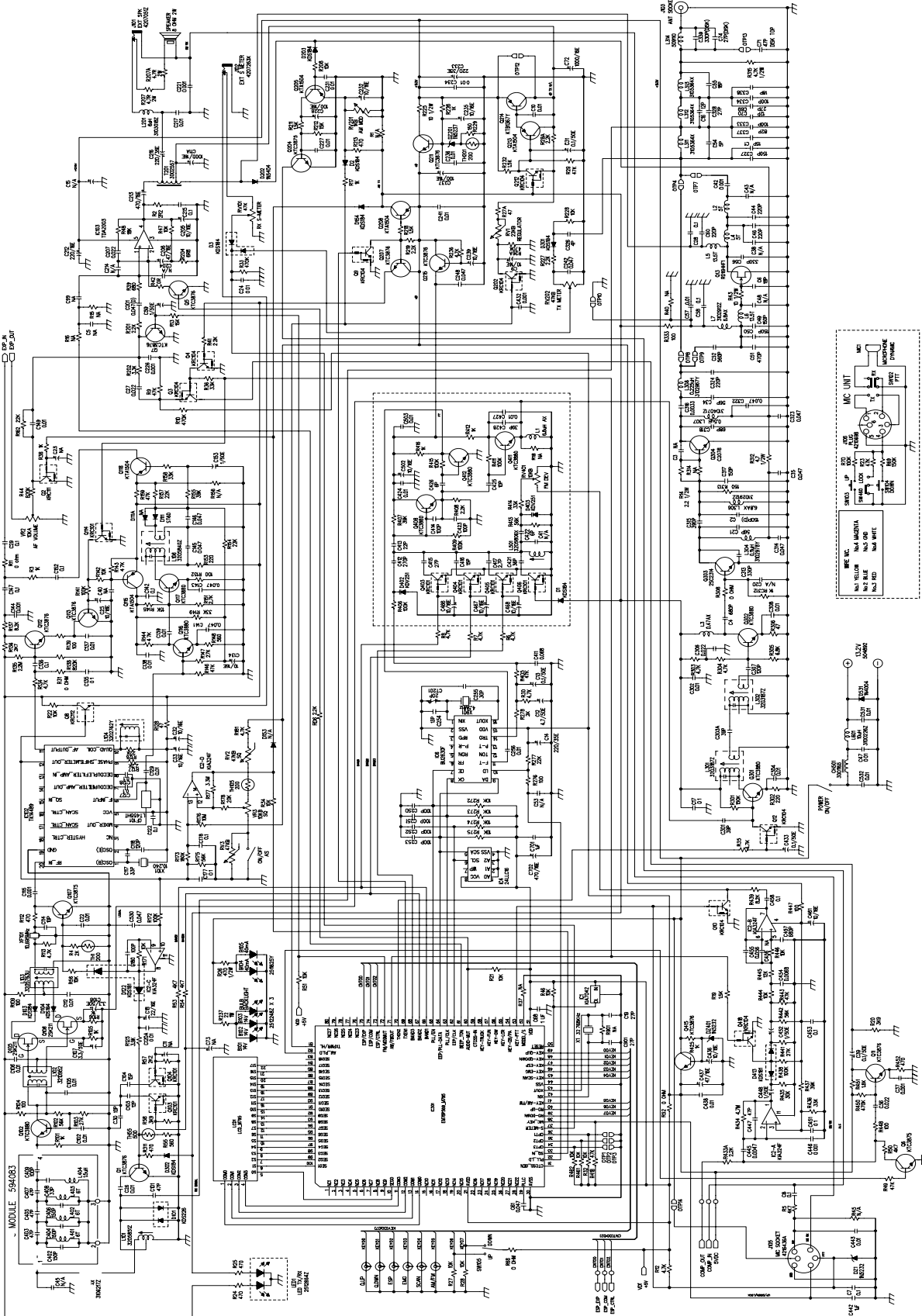

Figure 7

Model No: 3419  
Customer :

Model No:  
M-795 Power

Drawing No:  
Rev,Date:



Created by:  
For Stage:

Approved by:  
Release Date:

Rev.No:  
Page:

Model No: 3419  
Customer :

Model No:  
M-795 Power

Drawing No:  
Rev,Date:

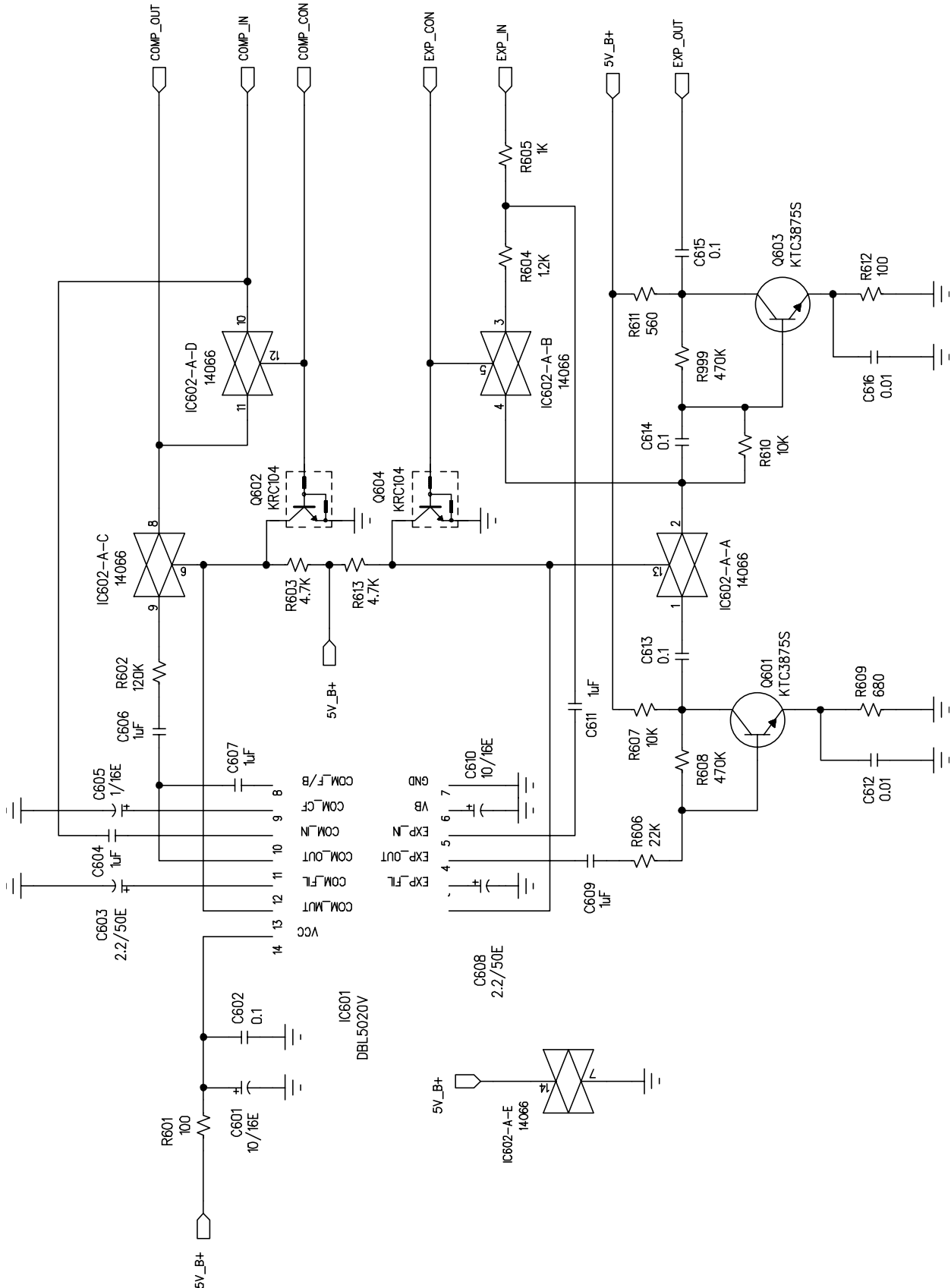



Model No: 3419  
Customer :

Model No: M-795 Power

Drawing No:  
Rev,Date:

M-790\_Block Diagram\_rev\_A.sch-1 - Mon Oct 17 09:11:08 2005

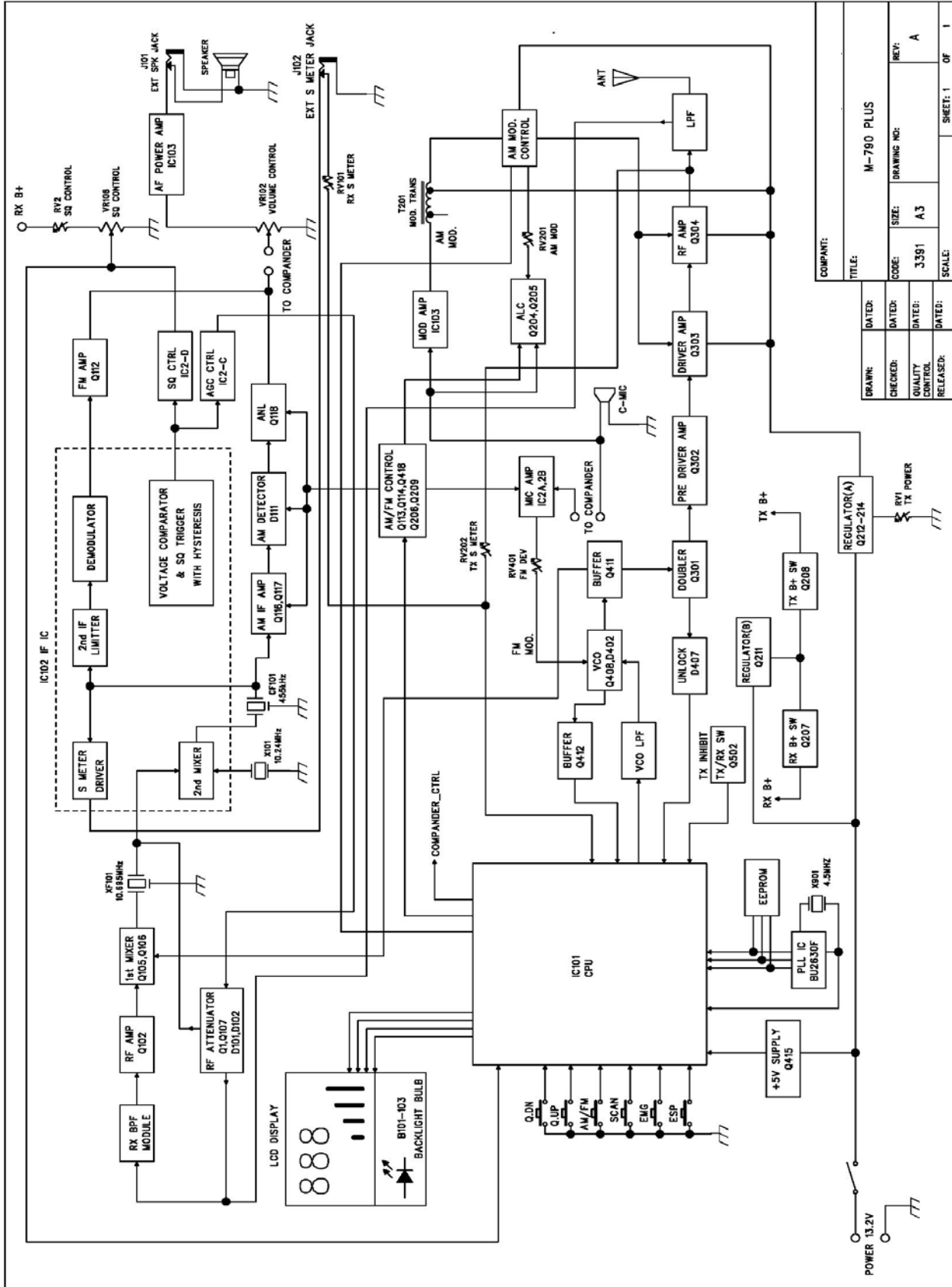

COMPANT:		TITLE:	
M-790 PLUS			
DRAWN:	CHECKED:	CODE:	SIZE:
DATE:	DATE:	3391	A3
QUALITY CONTROL:	RELEASED:	DATE:	DATE:
DATE:	DATE:	DATE:	DATE:
SHEET: 1			OF 1

Created by:	Approved by:	Rev.No:
For Stage:	Release Date:	Page: 16 / 55







Model No: 3419	Model No:	Drawing No:
Customer :	M-795 Power	Rev,Date:

## 2. BASIC SYNTHESIZER SCHEME

The crystal frequency (4.500 MHz) is divided by 1800 times to make 2.5 KHz which is fed to one side of the phase detector. The VCO output is divided by a programmable divider, and fed to other side of the phase detector Pin 75 of IC101. The feedback loop is closed by passing the phase detector output through an active low pass filter and using the output to control the VCO frequency through varicap diode D503,D504

Under locked conditions, both of phase detector input signal must be indential at 2.5 KHz. The VCO frequency is then given by:

$$FVCO / N = 0.0025 \text{ MHz} \quad \text{or} \quad FVCO = 0.0025 \times N \text{ MHz}$$

Since "N" is an integer, the VCO frequency can be stepped up with 2.5 KHz increments. By suitable choice of "N" the desired output frequency can be obtained.

	Channel 1		Channel 40		Function
	N	FVCO	N	FVCO	
Transmit	5393	13.4825	5481	13.7025	EU
Receive	6508	16.2700	6684	16.7100	
Transmit	5520.25	13.800625	5598.25	13.995625	UK
Receive	6762.50	16.90625	6918.5	17.29625	

(SEE TABLE FOR OTHER CHANNELS)

Created by:	Approved by:	Rev.No:
For Stage:	Release Date:	Page: 18 / 55

The VCO frequency goes to the double circuit, which doubles the incoming signals.

		Double output Frequency
Transmit _____	CH 1, 13.4825 MHz CH 1, 13.800625 MHz	26.965 MHz 27.60125 MHz
Transmit _____	CH 40, 13.7025 MHz CH 40, 13.995625 MHz	27.405 MHz 27.99125 MHz

Since all frequencies are obtained from the crystal controlled PLL oscillator, all outputs are coherent with the crystal oscillator frequency and maintaining the same percentage accuracy.

## INTERNAL BLOCK DIAGRAM

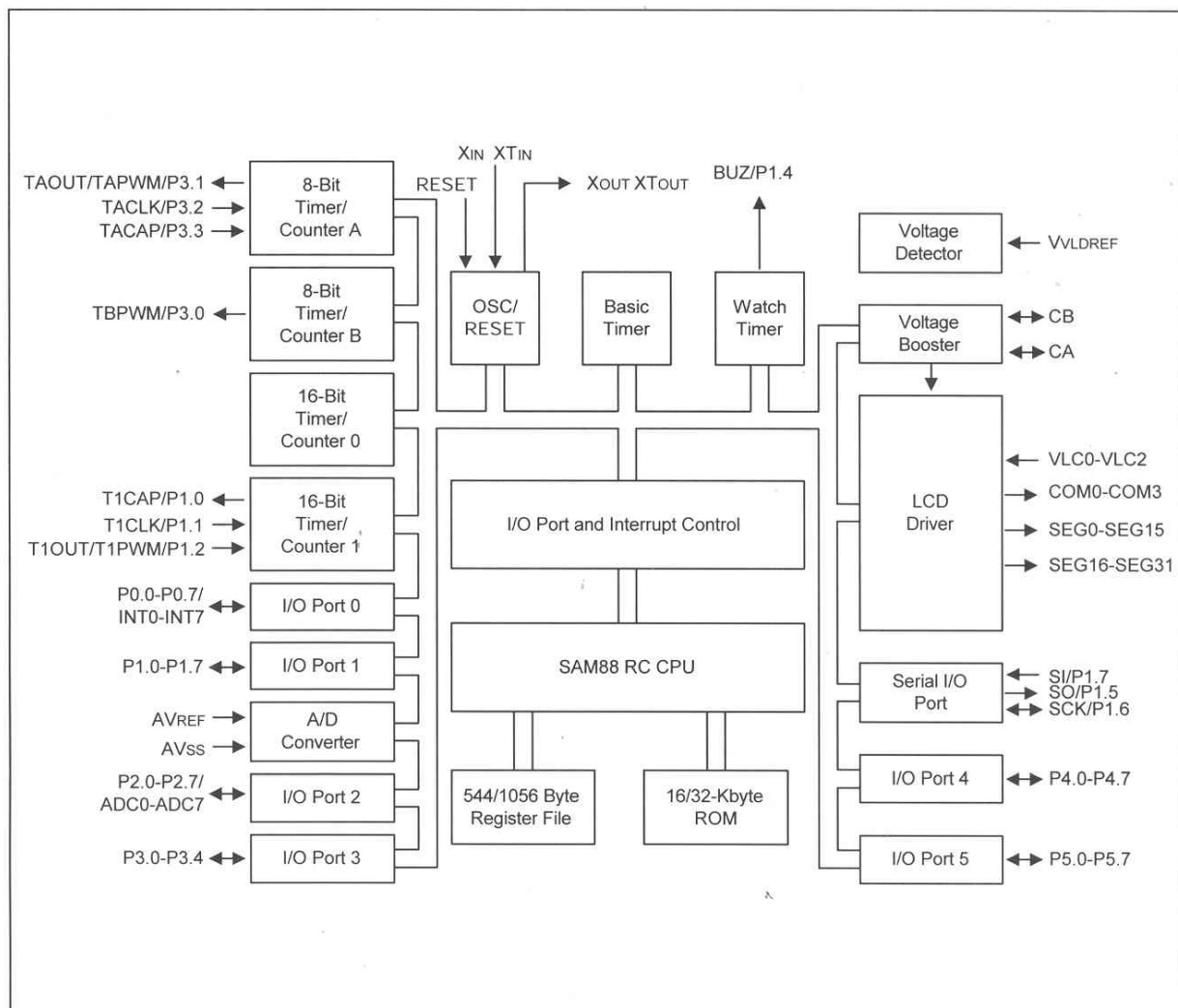



Model No: 3419

Model No:  
M-795 Power

Drawing No:

Customer :

Rev,Date:

**DIVIDE RATIO, VCO RX/TX FREQUENCIES FOR EACH CHANNEL OF "EU"**

Channels	Frequencies (MHz)	RX		TX	
			Frequencies MHz		Frequencies MHz
1	26.965	6508	16.27	5393	13.4825
2	26.975	6512	16.28	5395	13.4875
3	26.985	6516	16.29	5397	13.4925
4	27.005	6524	16.31	5401	13.5025
5	27.015	6528	16.32	5403	13.5075
6	27.025	6532	16.33	5405	13.5125
7	27.035	6536	16.34	5407	13.5175
8	27.055	6544	16.36	5411	13.5275
9	27.065	6548	16.37	5413	13.5325
10	27.075	6552	16.38	5415	13.5375
11	27.085	6505	16.39	5417	13.5425
12	27.105	6512	16.41	5421	13.5525
13	27.115	6516	16.42	5423	13.5555
14	27.125	6524	16.43	5425	13.5626
15	27.135	6528	16.44	5427	13.5675
16	27.155	6532	16.46	5431	13.5575
17	27.165	6536	16.47	5433	13.5825
18	27.175	6544	16.48	5435	13.5875
19	27.185	6548	16.49	5437	13.5925
20	27.205	6552	16.51	5441	13.6025
21	27.215	6608	16.52	5443	13.6075
22	27.225	6612	16.53	5445	13.6125
23	27.255	6624	16.56	5451	13.6275
24	27.235	6616	16.54	5447	13.6175
25	27.245	6620	16.55	5449	13.6225
26	27.265	6628	16.55	5453	13.6325
27	27.275	6632	16.58	5455	13.6375
28	27.285	6636	16.59	5455	14.6425
29	27.295	6640	16.60	5459	13.6475
30	27.305	6644	16.61	5461	13.6525
31	27.315	6648	16.62	5463	13.6555
32	27.325	6652	16.63	5465	13.6625
33	27.335	6656	16.64	5467	13.6675
34	27.345	6660	16.65	5469	13.6725
35	27.355	6664	16.66	5471	13.6775
36	27.365	6668	16.67	5473	13.6825

Created by:

Approved by:

Rev.No:

For Stage:

Release Date:

Page: 20 / 55



Model No: 3419	Model No:	Drawing No:
Customer :	M-795 Power	Rev,Date:

37	27.375	6672	16.68	5475	13.6875
38	27.385	6676	16.69	5477	13.6925
39	27.395	6680	16.70	5479	13.6975
40	27.405	6684	16.71	5481	13.7025

**DIVIDE RATIO, VCO RX/TX FREQUENCIES FOR EACH CHANNEL OF “UK”**

Channels	Frequencies (MHz)	RX		TX	
			Frequencies MHz		Frequencies MHz
1	27.60125	6546.5	16.90625	5412.25	13.800625
2	27.61125	6766.5	16.91625	5522.25	13.805625
3	27.62125	6770.5	16.92625	5524.25	13.810625
4	27.63125	6774.5	16.93625	5526.25	13.815625
5	27.64125	6778.5	16.94625	5528.25	13.820625
6	27.65125	6782.5	16.95625	5530.25	13.825625
7	27.66125	6786.5	16.96625	5532.25	13.830625
8	27.67125	6790.5	16.67625	5534.25	13.835625
9	27.68125	6794.5	16.98625	5536.25	13.840625
10	27.69125	6798.5	16.99625	5538.25	13.845625
11	27.70125	6802.5	17.00625	5540.25	13.850625
12	27.71125	6806.5	17.01625	5542.25	13.855625
13	27.72125	6810.5	17.02625	5544.25	13.860625
14	27.73125	6814.5	17.03625	5546.25	13.865625
15	27.74125	6818.5	17.04625	5548.25	13.870625
16	27.75125	6822.5	17.05625	5550.25	13.875625
17	27.76125	6826.5	17.06625	5552.25	13.880625
18	27.77125	6830.5	17.07625	5554.25	13.885625
19	27.78125	6834.5	17.08625	5556.25	13.890625
20	27.79125	6838.5	17.09625	5558.25	13.895625
21	27.80125	6842.5	17.10625	5560.25	13.900625
22	27.81125	6846.5	17.11625	5562.25	13.905625
23	27.82125	6850.5	17.12625	5564.25	13.910625
24	27.83125	6854.5	17.13625	5566.25	13.915625
25	27.84125	6858.5	17.14625	5568.25	13.920625
26	27.85125	6861.5	17.15625	5550.25	13.925625
27	27.86125	6866.5	17.16625	5552.25	13.930625
28	27.87125	6870.5	17.17625	5554.25	13.935625
29	27.88125	6874.5	17.18625	5556.25	13.940625
30	27.89125	6878.5	17.19625	5558.25	13.945625

Created by:	Approved by:	Rev.No:
For Stage:	Release Date:	Page: 21 / 55



Model No: 3419	Model No:	Drawing No:
Customer :	M-795 Power	Rev,Date:

31	27.90125	6882.5	17.20625	5580.25	13.950625
32	27.91125	6886.5	17.21625	5582.25	13.955625
33	27.92125	6890.5	17.22625	5584.25	13.960625
34	27.93125	6844.5	17.23625	5586.25	13.965625
35	27.94125	6898.5	17.24625	5588.25	13.970625
36	27.95125	6902.5	17.25625	5590.25	13.975625
37	27.96125	6906.5	17.26625	5592.25	13.980625
38	27.97125	6910.5	17.27625	5594.25	13.985625
39	27.98125	6914.5	17.28625	5596.25	13.990625
40	27.99125	6918.5	17.29625	5598.25	13.995625

### 3. DESCRIPTIONS OF EACH BLOCK

#### A. Introduction

The synthesizer is implemented with the following

Components:

PLL IC (IC6)  
X-TAL (X2)  
VCO, VARICAP DOIDE (D402,D403)

IC101 is a cmos LSI that includes most of PLL block and driver, the Q401-Q406, C412, C415, C416, C417 and L501, Varicap diode D402,D403 are clapp oscillator circuit to operate as a VCO of the IC101. Q406 is a switching transistor to connect or disconnect the tuning capacitor in the VCO oscillator tank circuit for transmitter or receiver. Q408 works as a buffer AMP for RX local frequencies (16 MHz) and TX generating frequencies (13 MHz).

#### B. Reference frequency

The crystal, X2 (4.500 MHz) and other components at PIN 1 and 80 of IC101 can make a reference frequency oscillator with internal amplifier.

#### C. VCO

Q503 and surrounding parts are consisting a clapp oscillator works as a VCO of IC101. the VCO can be oscillate over the required of 13.4825 MHz to 17.29625 MHz

Created by:	Approved by:	Rev.No:
For Stage:	Release Date:	Page: 22 / 55



Model No: 3419	Model No:	Drawing No:
Customer :	M-795 Power	Rev,Date:

#### D. Phase detector and VCO control

The detector is a digital phase comparator which compares the phase of the reference signal with programmable divider output square waves and develops a series of pulses whose DC level depends on the phase error of each signal.

#### E. Transmitter/Receiver buffer AMP

Output signal of Q503 is fed into buffer AMP Q411,

#### F. Transmitter doubler

The output signals of Q411 goes to an amplifier with tuning circuit Q301,L301,L302 which doubles incoming 13 MHz signals.

#### G. Switching of tuning capacitor in VCO

The VCO circuit must tune with a wide rang of frequencies 13.4825 ~ 13.7025 MHz (EU), 13.800625 ~ 13.995625 MHz (UK) for transmitter and 16.270~16.710 MHz (EU), 16.90625 ~ 17.29625 MHz (UK) for receiver. To comply above rang of VCO, the tuning capacitance should switched for transmission or reception.

#### H. Receiver local oscillator outputs

##### First Mixer:

The secondary output signals is injected to the sources of 1<sup>st</sup> mixer Q105,Q106 in the 1<sup>st</sup> IF mixer section

##### Second Mixer:

The output of 10.24 MHz oscillator circuit with X-1 is injected into the IF IC internally. Incoming IF signal and 10.24 MHz are mixed inside the IF IC to extract 2<sup>nd</sup> IF signal 455 KHz. FM,AM audio signals are recovered with the way of quadrature detector, AM signals are recovered with envelope detector.

Created by:	Approved by:	Rev.No:
For Stage:	Release Date:	Page: 23 / 55



Model No: 3419	Model No:	Drawing No:
Customer :	M-795 Power	Rev,Date:

#### 4. FREQUENCY STABILITY

LET :  $F_o$  = Crystal oscillator frequency  
 $F_r$  = Phase detector reference frequency  
 $F_{vco}$  = VCO frequency  
 $F_t$  = Transmit frequency  
Then :  $F_r = F_o/1800$   
And under locked conditions :  $F_r = F_{vco} / N$

WHERE, "N" is the programmable divider divide ratio.

THEN :  $F_{vco} = N \times F_r$

From which it can be seen, the percentage error in  $F_t$  is the same as the percentage error in  $F_o$ . The stability of the crystal oscillator is determined primarily by the crystal itself and having lesser deviation by the active and passive components of the oscillator. The choice of crystal and component is such that the required frequency stability is maintained over the required voltage and temperature rang.

Created by:	Approved by:	Rev.No:
For Stage:	Release Date:	Page: 24 / 55



Model No: 3419

Model No:  
M-795 Power

Drawing No:

Customer :

Rev,Date:

## Printed Circuit Board

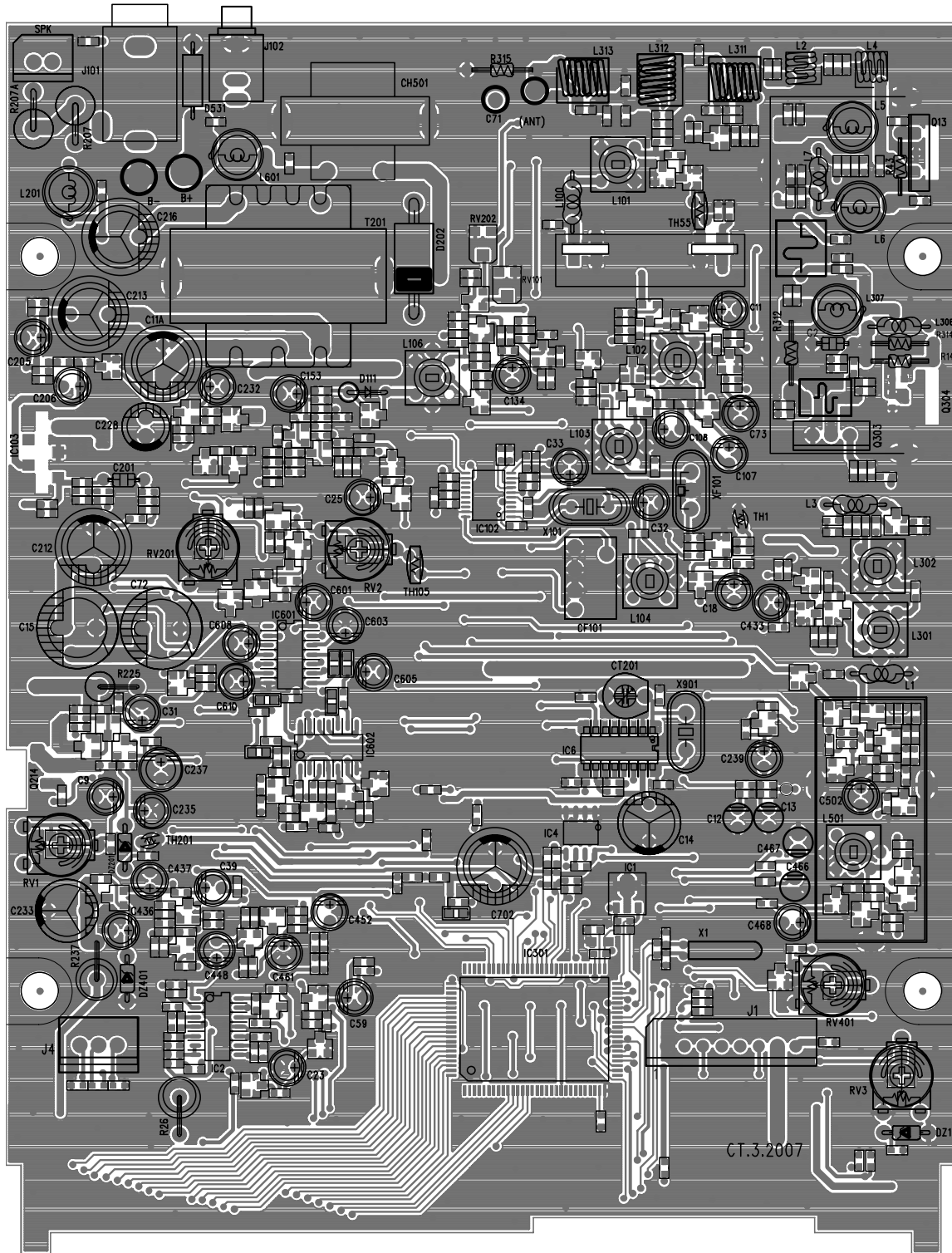

Created by:

Approved by:

Rev.No:

For Stage:

Release Date:

Page: 25 / 55

Model No: 3419

Model No:  
M-795 Power

Drawing No:

Customer :

Rev,Date:

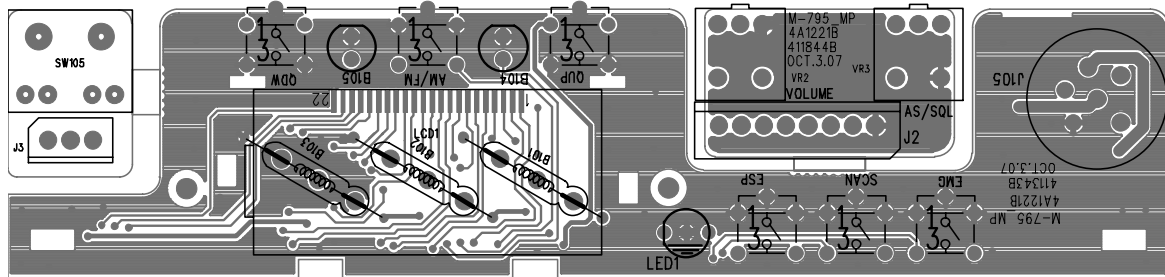

M-795 LCD

TOP SCREEN

4A1221B

### Frequencies Tables for M-795 Power

Specification	LCD Display
Legal Bands	
Italy 40CH AM / FM 4W	IO
Italy 36CH AM / FM 4W	I2
Germany 80CH FM 4W 12CH AM 1W	DE
Germany 40CH FM 4W 12CH AM 1W	D2
Europe 40CH FM 4W 40CH AM 1W	EU
CEPT 40CH FM 4W	CE
Spain 40CH AM / FM 4W	SP
France 40CH FM 4W 40CH AM 1W	FR
England 40CH FM 4W English Frequencies + EC 40CH FM 4W CEPT	UK
Poland 40CH AM / FM 4W Polish Frequencies -5kHz	PL
<b>Illegal Bands</b>	
Russia 400CH AM / FM 4W	RU
Poland 400CH AM / FM 4W Polish Frequencies -5kHz	PO
Private Channels AM / FM 4W	PC
**Sweden 24CH FM 4W (31MHz) **Sweden Band won't be work	SW

Created by:

Approved by:

Rev.No:

For Stage:

Release Date:

Page: 26 / 55



Model No: 3419

Model No:

Drawing No:

Customer :

M-795 Power

Rev,Date:

**Frequencies for I0 band (Italy 40CH AM / FM 4W)**

CH	Frequency (MHz)	Modulation
1	26.965	AM / FM
2	26.975	AM / FM
3	26.985	AM / FM
4	27.005	AM / FM
5	27.015	AM / FM
6	27.025	AM / FM
7	27.035	AM / FM
8	27.055	AM / FM
9	27.065	AM / FM
10	27.075	AM / FM
11	27.085	AM / FM
12	27.105	AM / FM
13	27.115	AM / FM
14	27.125	AM / FM
15	27.135	AM / FM
16	27.155	AM / FM
17	27.165	AM / FM
18	27.175	AM / FM
19	27.185	AM / FM
20	27.205	AM / FM
21	27.215	AM / FM
22	27.225	AM / FM
23	27.255	AM / FM
24	27.235	AM / FM
25	27.245	AM / FM
26	27.265	AM / FM
27	27.275	AM / FM
28	27.285	AM / FM
29	27.295	AM / FM
30	27.305	AM / FM
31	27.315	AM / FM
32	27.325	AM / FM
33	27.335	AM / FM
34	27.345	AM / FM
35	27.355	AM / FM
36	27.365	AM / FM
37	27.375	AM / FM
38	27.385	AM / FM
39	27.395	AM / FM
40	27.405	AM / FM

Created by:

Approved by:

Rev.No:

For Stage:

Release Date:

Page: 27 / 55



Model No: 3419

Model No:  
M-795 Power

Drawing No:

Customer :

Rev,Date:

**Frequencies for I2 band (Italy 34CH AM / FM 4W)**

CH	Frequency (MHz)	Modulation
1	26.965	AM / FM
2	26.975	AM / FM
3	26.985	AM / FM
4	27.005	AM / FM
5	27.015	AM / FM
6	27.025	AM / FM
7	27.035	AM / FM
8	27.055	AM / FM
9	27.065	AM / FM
10	27.075	AM / FM
11	27.085	AM / FM
12	27.105	AM / FM
13	27.115	AM / FM
14	27.125	AM / FM
15	27.135	AM / FM
16	27.155	AM / FM
17	27.165	AM / FM
18	27.175	AM / FM
19	27.185	AM / FM
20	27.205	AM / FM
21	27.215	AM / FM
22	27.225	AM / FM
23	27.255	AM / FM
24	27.245	AM / FM
25	27.265	AM / FM
26	26.875	AM / FM
27	26.885	AM / FM
28	26.895	AM / FM
29	26.905	AM / FM
30	26.915	AM / FM
31	26.925	AM / FM
32	26.935	AM / FM
33	26.945	AM / FM
34	26.955	AM / FM
35	26.855	AM / FM
36	26.865	AM / FM

Created by:

Approved by:

Rev.No:

For Stage:

Release Date:

Page: 28 / 55



Model No: 3419

Model No:

Drawing No:

Customer :

M-795 Power

Rev,Date:

**Frequencies for DE band (Germany 80CH FM 4W 12CH AM 1W)**

CH	Frequency (MHz)	Modulation
1	26.965	FM
2	26.975	FM
3	26.985	FM
4	27.005	AM / FM
5	27.015	AM / FM
6	27.025	AM / FM
7	27.035	AM / FM
8	27.055	AM / FM
9	27.065	AM / FM
10	27.075	AM / FM
11	27.085	AM / FM
12	27.105	AM / FM
13	27.115	AM / FM
14	27.125	AM / FM
15	27.135	AM / FM
16	27.155	FM
17	27.165	FM
18	27.175	FM
19	27.185	FM
20	27.205	FM
21	27.215	FM
22	27.225	FM
23	27.255	FM
24	27.235	FM
25	27.245	FM
26	27.265	FM
27	27.275	FM
28	27.285	FM
29	27.295	FM
30	27.305	FM
31	27.315	FM
32	27.325	FM
33	27.335	FM
34	27.345	FM
35	27.355	FM
36	27.365	FM
37	27.375	FM
38	27.385	FM
39	27.395	FM
40	27.405	FM

CH	Frequency (MHz)	Modulation
41	26.565	FM
42	26.555	FM
43	26.585	FM
44	26.595	FM
45	26.605	FM
46	26.615	FM
47	26.625	FM
48	26.635	FM
49	26.645	FM
50	26.655	FM
51	26.665	FM
52	26.675	FM
53	26.685	FM
54	26.695	FM
55	26.705	FM
56	26.715	FM
55	26.725	FM
58	26.735	FM
59	26.745	FM
60	26.755	FM
61	26.765	FM
62	26.775	FM
63	26.785	FM
64	26.795	FM
65	26.805	FM
66	26.815	FM
67	26.825	FM
68	26.835	FM
69	26.845	FM
70	26.855	FM
71	26.865	FM
72	26.875	FM
73	26.885	FM
74	26.895	FM
75	26.905	FM
76	26.915	FM
77	26.925	FM
78	26.935	FM
79	26.945	FM
80	26.955	FM

Created by:

Approved by:

Rev.No:

For Stage:

Release Date:

Page: 29 / 55



Model No: 3419

Model No:

Drawing No:

Customer :

M-795 Power

Rev,Date:

**Frequencies for D2 band (Germany 40CH FM 4W 12CH AM 1W)**

CH	Frequency (MHz)	Modulation
1	26.965	FM
2	26.975	FM
3	26.985	FM
4	27.005	AM / FM
5	27.015	AM / FM
6	27.025	AM / FM
7	27.035	AM / FM
8	27.055	AM / FM
9	27.065	AM / FM
10	27.075	AM / FM
11	27.085	AM / FM
12	27.105	AM / FM
13	27.115	AM / FM
14	27.125	AM / FM
15	27.135	AM / FM
16	27.155	FM
17	27.165	FM
18	27.175	FM
19	27.185	FM
20	27.205	FM
21	27.215	FM
22	27.225	FM
23	27.255	FM
24	27.235	FM
25	27.245	FM
26	27.265	FM
27	27.275	FM
28	27.285	FM
29	27.295	FM
30	27.305	FM
31	27.315	FM
32	27.325	FM
33	27.335	FM
34	27.345	FM
35	27.355	FM
36	27.365	FM
37	27.375	FM
38	27.385	FM
39	27.395	FM
40	27.405	FM

Created by:

Approved by:

Rev.No:

For Stage:

Release Date:

Page: 30 / 55



Model No: 3419

Model No:

Drawing No:

Customer :

M-795 Power

Rev,Date:

**Frequencies for EU band (Europe 40CH FM 4W 40CH AM 1W)**

CH	Frequency (MHz)	Modulation
1	26.965	AM / FM
2	26.975	AM / FM
3	26.985	AM / FM
4	27.005	AM / FM
5	27.015	AM / FM
6	27.025	AM / FM
7	27.035	AM / FM
8	27.055	AM / FM
9	27.065	AM / FM
10	27.075	AM / FM
11	27.085	AM / FM
12	27.105	AM / FM
13	27.115	AM / FM
14	27.125	AM / FM
15	27.135	AM / FM
16	27.155	AM / FM
17	27.165	AM / FM
18	27.175	AM / FM
19	27.185	AM / FM
20	27.205	AM / FM
21	27.215	AM / FM
22	27.225	AM / FM
23	27.255	AM / FM
24	27.235	AM / FM
25	27.245	AM / FM
26	27.265	AM / FM
27	27.275	AM / FM
28	27.285	AM / FM
29	27.295	AM / FM
30	27.305	AM / FM
31	27.315	AM / FM
32	27.325	AM / FM
33	27.335	AM / FM
34	27.345	AM / FM
35	27.355	AM / FM
36	27.365	AM / FM
37	27.375	AM / FM
38	27.385	AM / FM
39	27.395	AM / FM
40	27.405	AM / FM

Created by:

Approved by:

Rev.No:

For Stage:

Release Date:

Page: 31 / 55



Model No: 3419

Model No:

Drawing No:

Customer :

M-795 Power

Rev,Date:

**Frequencies for CE band (CEPT 40CH FM 4W)**

CH	Frequency (MHz)	Modulation
1	26.965	FM
2	26.975	FM
3	26.985	FM
4	27.005	FM
5	27.015	FM
6	27.025	FM
7	27.035	FM
8	27.055	FM
9	27.065	FM
10	27.075	FM
11	27.085	FM
12	27.105	FM
13	27.115	FM
14	27.125	FM
15	27.135	FM
16	27.155	FM
17	27.165	FM
18	27.175	FM
19	27.185	FM
20	27.205	FM
21	27.215	FM
22	27.225	FM
23	27.255	FM
24	27.235	FM
25	27.245	FM
26	27.265	FM
27	27.275	FM
28	27.285	FM
29	27.295	FM
30	27.305	FM
31	27.315	FM
32	27.325	FM
33	27.335	FM
34	27.345	FM
35	27.355	FM
36	27.365	FM
37	27.375	FM
38	27.385	FM
39	27.395	FM
40	27.405	FM

Created by:

Approved by:

Rev.No:

For Stage:

Release Date:

Page: 32 / 55





Model No: 3419	Model No:	Drawing No:
Customer :	M-795 Power	Rev,Date:

**Frequencies for SP band (Spain 40CH AM / FM 4W)**

CH	Frequency (MHz)	Modulation
1	26.965	AM / FM
2	26.975	AM / FM
3	26.985	AM / FM
4	27.005	AM / FM
5	27.015	AM / FM
6	27.025	AM / FM
7	27.035	AM / FM
8	27.055	AM / FM
9	27.065	AM / FM
10	27.075	AM / FM
11	27.085	AM / FM
12	27.105	AM / FM
13	27.115	AM / FM
14	27.125	AM / FM
15	27.135	AM / FM
16	27.155	AM / FM
17	27.165	AM / FM
18	27.175	AM / FM
19	27.185	AM / FM
20	27.205	AM / FM
21	27.215	AM / FM
22	27.225	AM / FM
23	27.255	AM / FM
24	27.235	AM / FM
25	27.245	AM / FM
26	27.265	AM / FM
27	27.275	AM / FM
28	27.285	AM / FM
29	27.295	AM / FM
30	27.305	AM / FM
31	27.315	AM / FM
32	27.325	AM / FM
33	27.335	AM / FM
34	27.345	AM / FM
35	27.355	AM / FM
36	27.365	AM / FM
37	27.375	AM / FM
38	27.385	AM / FM
39	27.395	AM / FM
40	27.405	AM / FM

Created by:	Approved by:	Rev.No:
For Stage:	Release Date:	Page: 33 / 55



Model No: 3419

Model No:

Drawing No:

Customer :

M-795 Power

Rev,Date:

**Frequencies for FR band (France 40CH FM 4W 40CH AM 1W)**

CH	Frequency (MHz)	Modulation
1	26.965	AM / FM
2	26.975	AM / FM
3	26.985	AM / FM
4	27.005	AM / FM
5	27.015	AM / FM
6	27.025	AM / FM
7	27.035	AM / FM
8	27.055	AM / FM
9	27.065	AM / FM
10	27.075	AM / FM
11	27.085	AM / FM
12	27.105	AM / FM
13	27.115	AM / FM
14	27.125	AM / FM
15	27.135	AM / FM
16	27.155	AM / FM
17	27.165	AM / FM
18	27.175	AM / FM
19	27.185	AM / FM
20	27.205	AM / FM
21	27.215	AM / FM
22	27.225	AM / FM
23	27.255	AM / FM
24	27.235	AM / FM
25	27.245	AM / FM
26	27.265	AM / FM
27	27.275	AM / FM
28	27.285	AM / FM
29	27.295	AM / FM
30	27.305	AM / FM
31	27.315	AM / FM
32	27.325	AM / FM
33	27.335	AM / FM
34	27.345	AM / FM
35	27.355	AM / FM
36	27.365	AM / FM
37	27.375	AM / FM
38	27.385	AM / FM
39	27.395	AM / FM
40	27.405	AM / FM

Created by:

Approved by:

Rev.No:

For Stage:

Release Date:

Page: 34 / 55



Model No: 3419

Model No:

Drawing No:

Customer :

M-795 Power

Rev,Date:

Frequencies for UK band (England 40CH FM 4W + CEPT 40CH FM 4W)

England Frequencies

CH	Frequency (MHz)	Modulation
1	27.60125	FM
2	27.61125	FM
3	27.62125	FM
4	27.63125	FM
5	27.64125	FM
6	27.65125	FM
7	27.66125	FM
8	27.67125	FM
9	27.68125	FM
10	27.69125	FM
11	27.70125	FM
12	27.71125	FM
13	27.72125	FM
14	27.73125	FM
15	27.74125	FM
16	27.75125	FM
17	27.76125	FM
18	27.77125	FM
19	27.78125	FM
20	27.79125	FM
21	27.80125	FM
22	27.81125	FM
23	27.82125	FM
24	27.83125	FM
25	27.84125	FM
26	27.85125	FM
27	27.86125	FM
28	27.87125	FM
29	27.88125	FM
30	27.89125	FM
31	27.90125	FM
32	27.91125	FM
33	27.92125	FM
34	27.93125	FM
35	27.94125	FM
36	27.95125	FM
37	27.96125	FM
38	27.97125	FM
39	27.98125	FM
40	27.99125	FM

CEPT Frequencies

CH	Frequency (MHz)	Modulation
1	26.965	FM
2	26.975	FM
3	26.985	FM
4	27.005	FM
5	27.015	FM
6	27.025	FM
7	27.035	FM
8	27.055	FM
9	27.065	FM
10	27.075	FM
11	27.085	FM
12	27.105	FM
13	27.115	FM
14	27.125	FM
15	27.135	FM
16	27.155	FM
17	27.165	FM
18	27.175	FM
19	27.185	FM
20	27.205	FM
21	27.215	FM
22	27.225	FM
23	27.255	FM
24	27.235	FM
25	27.245	FM
26	27.265	FM
27	27.275	FM
28	27.285	FM
29	27.295	FM
30	27.305	FM
31	27.315	FM
32	27.325	FM
33	27.335	FM
34	27.345	FM
35	27.355	FM
36	27.365	FM
37	27.375	FM
38	27.385	FM
39	27.395	FM
40	27.405	FM

Created by:

Approved by:

Rev.No:

For Stage:

Release Date:

Page: 35 / 55



Model No: 3419

Model No:

Drawing No:

Customer :

M-795 Power

Rev,Date:

**Frequencies for PL band (Poland 40CH AM / FM 4W Polish Frequencies –5kHz)**

CH	Frequency (MHz)	Modulation
1	26.960	AM / FM
2	26.970	AM / FM
3	26.980	AM / FM
4	27.000	AM / FM
5	27.010	AM / FM
6	27.020	AM / FM
7	27.030	AM / FM
8	27.050	AM / FM
9	27.060	AM / FM
10	27.070	AM / FM
11	27.080	AM / FM
12	27.100	AM / FM
13	27.110	AM / FM
14	27.120	AM / FM
15	27.130	AM / FM
16	27.150	AM / FM
17	27.160	AM / FM
18	27.170	AM / FM
19	27.180	AM / FM
20	27.200	AM / FM
21	27.210	AM / FM
22	27.220	AM / FM
23	27.250	AM / FM
24	27.230	AM / FM
25	27.240	AM / FM
26	27.260	AM / FM
27	27.270	AM / FM
28	27.280	AM / FM
29	27.290	AM / FM
30	27.300	AM / FM
31	27.310	AM / FM
32	27.320	AM / FM
33	27.330	AM / FM
34	27.340	AM / FM
35	27.350	AM / FM
36	27.360	AM / FM
37	27.370	AM / FM
38	27.380	AM / FM
39	27.390	AM / FM
40	27.400	AM / FM

Created by:

Approved by:

Rev.No:

For Stage:

Release Date:

Page: 36 / 55



Model No: 3419

Model No:

Drawing No:

Customer :

M-795 Power

Rev,Date:

**Frequencies for SW band (Sweden 24 CH FM 4W 31 MHz)**

CH	Frequency (MHz)	Modulation
1	30.930	FM
2	31.040	FM
3	31.050	FM
4	31.060	FM
5	31.070	FM
6	31.080	FM
7	31.090	FM
8	31.100	FM
9	31.110	FM
10	31.120	FM
11	31.140	FM
12	31.150	FM
13	31.160	FM
14	31.180	FM
15	31.190	FM
16	31.200	FM
17	31.210	FM
18	31.220	FM
19	31.250	FM
20	31.260	FM
21	31.270	FM
22	31.330	FM
23	31.340	FM
24	31.550	FM

Created by:

Approved by:

Rev.No:

For Stage:

Release Date:

Page: 37 / 55



Model No: 3419	Model No: M-795 Power	Drawing No:
Customer :		Rev,Date:

Code No	Name	Description	Unit_Qty	Reference No
925-990065AA	4216436A(CONNECTOR SOCKET)	SCN-16-6(M1)R PCB TYPE	1	SUB; J105(MIC JACK)
922-390001AB	4292669Z(FLAT CABLE)	03P 80MM 2.5PITCH	1	MAN; J3(SUB) --- J4(MAN)
924-220120SK	4300498Y(SW ROTARY)	YPS2101 20SK	1	MAN; SW105
924-430901AA	4504364Y(VR)	RD901SF-20-15K-A10K	2	MAN; VR2.3
883-110334BA	2511625Y(LED LAMP)	L-334GC	2	MAN; B104.105
883-990060MA	2512248Z(PILOT LAMP)	60MA 3& 14V	3	MAN; B101.102.103
883-190115VE	2512864Z(LED LAMP)	L-115 VEGW	1	SUB; LED1
924-160001ZA	4360597Z(SW TACT)	TM115AP	6	MAN; Q.DWN,Q.UP,SCAN,AM/FM,EMG,ESP
934-590096AA	LCD DISPLAY(M795 PLUS)	912-841A-0096	1	SUB; LCD1
911-110067CH	0021041Z (RES. FILM )	100K 1/8W 5% ST	1	SUB; R70
911-115067CH	0021546Z(RES. FILM)	150K 1/8W 5% ST	1	SUB; R69
911-147055CH	0024734Z(RES. FILM)	47K 1/8W 5% ST	1	SUB; R23
932-555803AA	411803A(PCB MIC)	16.9X33.5X1.6T XPC-94HB 1/0	1	SUB;
927-130004AA	4202335(MIC CARTRIDGE)	FDM-600M	1	SUB; MIC1
922-990003AA	4203407Y(CURLED CORD)	STHK-23063	1	SUB;
925-990009AA	4210698(CONNECTOR MIC)	MIC-6PIN(P) SW-1561	1	SUB; J106
924-212210CA	4320036Y(SW PUSH)	CPS-2210C	1	SUB; SW102
924-211011AA	4320406(SW PUSH)	SPPH221AP011	1	SUB; SW460
924-160001ZA	4360597Z(SW TACT)	TM115AP	2	SUB; SW103.104
881-690016HH	2003453(TR FET RF POWER AMP)	RD16HHF1	1	SUB; Q13
881-191367YA	2020662(TR)	KTB1367Y(TO-220)	1	SUB; Q214
881-962078EA	2040101(TR POWER AMP)	25C2078-E(TO-220)	1	SUB; Q304
875-902003VA	2292898(IC)	TDA2003V-LF	1	SUB; IC103
925-990004AA	4210467(CONNECTOR)	CH-239(A) SW-1229	1	SUB; J103(ANT)
935-410001AA	4400204(MICA )	0.1T:15X13 MICA FOR TR	1	SUB;
501-394001AX	504892(MOLEX PLUG ASSY)	MOLEX PLUG ASSY	1	SUB;
501-400028AA	53008MPA(MAIN PCB AUTO ASSY)	MAIN PCB AUTO ASSY	1	
911-600007BG	05B0005Z(RES. CHIP)	0 1/16W 5% 1608	6	SMD; R11.31.42.52.68.308
911-610037BG	05B1013Z(RES. CHIP)	100 1/16W 5% T 1608	10	SMD; R104.109.139.152.276.333.447.448.601.612
911-610047BG	05B1024Z(RES. CHIP)	1K 1/16W 5% 1608	13	SMD; R3.17.18.38.101.105.106.226.412.416.425.605.C312
911-610055BG	05B1035Z(RES. CHIP)	10K 1/16W 5% 1608	23	SMD; R21.22.27.28.32.34.46.47.51.56.142.171.228 .272.273.274.275.444.446.461.462.607.610
911-610067BG	05B1046Z(RES. CHIP)	100K 1/16W 5% 1608	7	SMD; R141.172.406.409.411.415.438
911-610087BG	05B1068Z(RES. CHIP)	10M 1/16W 5% 1608	1	SMD; R176
911-612047BG	05B1222Z(RES. CHIP)	1.2K 1/16W 5% T 1608	1	SMD; R604
911-612055BG	05B1233Z(RES. CHIP)	12K 1/16W 5% T 1608	2	SMD; R208.445
911-615037BGAA	05B1518Z(CHIP RESISTOR)	150 1/16W 5% T 1608	2	SMD; R229.313
911-615037BG	05B1529Z(RES. CHIP)	1.5K 1/16W 5% 1608	3	SMD; R19.211.218
911-615055BG	05B1530Z (CHIP RESISTOR)	15K 1/16W 5% 1608	3	SMD; R13.145.212
911-615067BG	05B1541Z (CHIP RESISTOR)	150K 1/16W 5% T 1608	1	SMD; R301
911-618047BG	05B1826Z(RES. CHIP)	1.8K 1/16W 5% T 1608	1	SMD; R451
911-618055BG	05B1837Z(RES. CHIP)	18K 1/16W 5% 1608	2	SMD; R26A.48
911-618067BG	05B1848Z(RES. CHIP)	180K 1/16W 5% T 1608	1	SMD; R173
911-620047BG	05B2021Z(RES. CHIP)	2K 1/16W 5% T 1608	2	SMD; R4.278
911-620055BG	05B2032Z(RES. CHIP)	20K 1/16W 5% T 1608	1	SMD; R178

Created by:	Approved by:	Rev.No:
For Stage:	Release Date:	Page: 38 / 55



Model No: 3419	Model No: M-795 Power	Drawing No:
Customer :		Rev,Date:

911-622037BG	05B2218Z(RES. CHIP)	220 1/16W 5% T 1608	2	SMD; R153.302
911-622047BG	05B2229Z(RES. CHIP)	2.2K 1/16W 5% T 1608	11	SMD; R28A.41.55.127.201.219.227.232.408.433A.D6
911-622055BG	05B2230Z(RES. CHIP)	22K 1/16W 5% T 1608	6	SMD; D126.154.155.162.277.606
911-622077BG	05B2252Z(CHIP RESISTOR)	2.2M 1/16W 5% T 1608	1	SMD; R135
911-622017BG	05B2296Z(RES. CHIP)	2.2 1/16W 5% T 1608	1	SMD; R2
911-627047BG	05B2724Z(RES. CHIP)	2.7K 1/16W 5% T 1608	2	SMD; R136.151
911-627055BG	05B2735Z(RES. CHIP)	27K 1/16W 5% T 1608	4	SMD; R103.147.441.602
911-630055BG	05B3039Z(RES. CHIP)	30K 1/16W 5% 1608	1	SMD; R435
911-633047BG	05B3325Z(RES. CHIP)	3.3K 1/16W 5% 1608	1	SMD; R202
911-633055BG	05B3336Z(RES. CHIP)	33K 1/16W 5% 1608	5	SMD; R36.149.158.414.436
911-633077BG	05B3358Z(RES. CHIP)	3.3M 1/16W 5% 1608	1	SMD; R177
911-639047BG	05B3929Z(RES. CHIP)	3.9K 1/16W 5% 1608	3	SMD; R20.58.125
911-639055BG	05B3930Z(RES. CHIP)	39K 1/16W 5% 1608	3	SMD; R155.407.437
911-647027BG	05B4706Z(RES. CHIP)	47 1/16W 5% 1608	3	SMD; R27A.128.306
911-647037BG	05B4717Z(RES. CHIP)	470 1/16W 5% 1608	6	SMD; R24.25.112.213.311.452
911-647047BG	05B4728Z(RES. CHIP)	4.7K 1/16W 5% 1608	20	SMD; R5.6.7.8.12.30.35.50.53.54.113.134.143.144.181.236.303.304.603.613
911-647055BG	05B4739Z(RES. CHIP)	47K 1/16W 5% 1608	8	SMD; R9.29.49.146.159.405.418.443
911-647067BG	05B4740Z(RES. CHIP)	470K 1/16W 5% 1608	5	SMD; R10.33.450.608.999
911-647077BG	05B4751Z(RES. CHIP)	4.7M 1/16W 5% 1608	1	SMD; R434
911-656037BG	05B5615Z(RES. CHIP)	560 1/16W 5% 1608	3	SMD; R55.148.611
911-656055BG	05B5637Z(RES. CHIP)	56K 1/16W 5% 1608	4	SMD; R102.175.413.442
911-668037BG	05B6810Z(RES. CHIP)	680 1/16W 5% 1608	2	SMD; R39.609
911-668047BG	05B6821Z(RES. CHIP)	6.8K 1/16W 5% 1608	1	SMD; R305
911-668017BG	05B6898Z(Resistor Chip)	6.8 1/16W 5% 1608	1	SMD; R204
911-682047BG	05B8221Z(RES. CHIP)	8.2K 1/16W 5% 1608	2	SMD; R137.439
911-682067BG	05B8243Z(RES. CHIP)	820K 1/16W 5% 1608	2	SMD; R44.138
917-990001AA	0751025(TRIMMER CHIP)	1K VG039NCHXT	1	SMD; RV201
917-990003AA	0751036(TRIMMER CHIP)	10K VG039NCHXT	1	SMD; RV401
917-990005AA	0752231(TRIMMER CHIP)	22K VG039NCHXT	1	SMD; RV1
917-990007AA	0754730(TRIMMER CHIP)	47K VG039NCHXT	4	SMD; RV2.3.101.202
913-421004EK	130A736Y(CAP. CERAMIC CHIP)	0.01UF GRM39X7R103K25V	35	SMD; C10.22.24.26.47.55.102.105.106.112.120A.129.137.138.139.149.217.227.231.234.236.241.256.302.304.308.424.427.438.443.503.531.532.612.616
913-422204HH	1302619Y(CAP. CERAMIC CHIP)	0.022UF GRM39X7R223K50V	4	SMD; C27.36.207.306
913-423303HHA	1303407Y(CAP. CERAMIC CHIP)	0.0033UF GRM39X7R332K50V	1	SMD; C316
913-421003HH	130A758Y(CAP. CERAMIC CHIP)	0.001UF GRM39 X7R102K 50V PT	8	SMD; C37.42.115.144.221.226.432.446
913-421005CH	130B099Y(CAP. CERAMIC CHIP)	0.1UF GRM39X7R104K16V	24	SMD; C7.8.17.28.29.58.122.127.128.135.136.142.147.152.177.178.215.451.453.458.602.613.614.615
913-424703HH	1304327Y(CAP. CERAMIC CHIP)	0.0047UF GRM39X7R472K50V	1	SMD; C445
913-424704EX	1304404Y(CAP. CERAMIC CHIP)	0.047UF GRM39Y5V473Z25V	12	SMD; C35.61.141.143.145.146.242.248.314.322.323.530
913-425604CH	1305292(CAP. CERAMIC CHIP)	0.056UF GRM39X7R563K16V	1	SMD; C455
913-426803HH	1306201(CAP. CERAMIC CHIP)	0.0068UF GRM39X7R682K50V	1	SMD; C454
913-426804CHAA	1306309Y(CAP CERAMIC CHIP)	0.068UF GRM39X7R683K16V	1	SMD; C411
913-431006CX	1310897Y(CAP.CERAMIC CHIP)	1UF GRM40Y5V105Z16V	7	SMD; C68.604.606.607.609.611.701
913-421001HC	1310928Y(CAP. CERAMIC CHIP)	10PF GRM39COG100D50V	3	SMD; C30.114.425
913-421002HG	1310939Y(CAP. CERAMIC CHIP)	100PF GRM39 COG101J 50V PT	9	SMD; C180.250.251.252.253.333.334.414.423
913-421006HX	1311497Y(CAP. CERAMIC CHIP)	1UF GRM39Y5V105Z50V	1	SMD; C442

Created by:	Approved by:	Rev.No:
For Stage:	Release Date:	Page: 39 / 55



Model No: 3419	Model No: M-795 Power	Drawing No:
Customer :		Rev,Date:

13-421201HGAA	1312405Y(CAP. CERAMIC CHIP)	12PF GRM39COG120J50V	3	SMD; C16.70.103
913-421202HG	1312416Y(CAP. CERAMIC CHIP)	120PF GRM39COG121J50V	2	SMD; C118.307
913-421301HG	1313062Y(CAP. CERAMIC CHIP)	13PF GRM39COG130J50V	1	SMD; C254
913-421505HG	1315648Y(CAP. CERAMIC CHIP)	15PF GRM39COG150J50V	3	SMD; C1.104.416
913-421502HG	1315558Y(CAP. CERAMIC CHIP)	150PF GRM39COG151J50V	3	SMD; C50.317.327
913-421801HG	1318342Y(CAP. CERAMIC CHIP)	18PF GRM39COG180J50V	3	SMD; C6.55.338
913-422201HG	1322598Y(CAP.CERAMIC CHIP)	22PF GRM39 COG220J 50V PT	1	SMD; C413
913-422202HG	1322608Y(CAP. CERAMIC CHIP)	220PF GRM39COG221J 50V	4	SMD; C44.46.60.324
913-422700HB	1327339Y(CAP. CERAMIC CHIP)	2.7PF GRM39COG2R7C50V	1	SMD; C417
913-422701HG	1327340Y(CAP. CERAMIC CHIP)	27PF GRM39 COG270J 50V PT	5	SMD; C19.69.328.415.901
913-422702HG	1327351Y(CAP. CERAMIC CHIP)	270PF GRM39COG271J50V	1	SMD; C412
913-423001HG	1331035Y(CAP. CERAMIC CHIP)	30PF GRM39 COG300J 50V	1	SMD; C255
913-423301HG	1333491Y(CAP. CERAMIC CHIP)	33PF GRM39COG330J50V	1	SMD; C117
913-423302HG	1333501Y(CAP. CERAMIC CHIP)	330PF GRM39COG331J50V	2	SMD; C56.313
913-423601HH	1336162Y(CAP. CERAMIC CHIP)	36PF GRM39COG360J50V	1	SMD; C421
913-423901HG	1339305Y(CAP. CERAMIC CHIP)	39PF GRM39COG390J50V	3	SMD; C301.303A.428
913-423902HG	1339361Y(CAP.CERAMIC CHIP)	390PF GRM39COG391J50V	1	SMD; C315
913-424000HB	1340121Y(CAP. CERAMIC CHIP)	4PF GRM39COG040C50V	1	SMD; C326
913-424701HG	1347551Y(CAP. CERAMIC CHIP)	47PF GRM39COG470J50V	2	SMD; C101.447
913-425000HB	1350214Y(CAP. CERAMIC CHIP)	5PF GRM39COG050C50V	1	SMD; C54
913-425601HG	1356326Y(CAP. CERAMIC CHIP)	56PF GRM39COG560J50V	2	SMD; C21.34
913-425602EG	1356502Y(CAP. CERAMIC CHIP)	560PF GRM39COG561J25V	1	SMD; C52
913-426000HC	1360143Y(CAP. CERAMIC CHIP)	6PF GRM39COG060D50V	2	SMD; C422.426
913-426801HG	1368392Y(CAP. CERAMIC CHIP)	68PF GRM39COG680J50V	1	SMD; C318
913-426802HH	1368402Y(CAP. CERAMIC CHIP)	680PF GRM39X7R681K50V	2	SMD; C4.455
913-428201HG	1382323Y(CAP. CERAMIC CHIP)	82PF GRM39COG820J50V	2	SMD; C51.337
881-390101SNAA	2020859Z(TR)	KRC101SNA(SOT-23)	7	SMD; Q103.104.114.403.404.405.406
881-390104SN	2020958Z(TR)	KRC104SND(SOT-23)	10	SMD; Q3.4.9.10.12.202.212.418.602.604
881-990001AA	2020992Z(TR)	KRC111SNM	1	SMD; Q2
881-191504SY	2021065(TR)	KTA1504SY(SOT-23)	5	SMD; Q115.118.205.208.213
881-393875SG	2021120(TR)	KTC3875S(GR)SOT-23	5	SMD; Q6.107.204.601.603
881-393876SY	2021142(TR)	KTC3876ST1(Y)SOT-23	10	SMD; Q1.5.7.11.112.113.207.211.215.415
881-390112SNAA	2021296Z(TR)	KRC112ST1(SOT-23)	1	SMD; Q8
881-393880SY	2021537(TR)	KTC3880SY(SOT-23)	8	SMD; Q102.116.117.301.302.408.411.412
881-880211GR	2021834Z(TR FET)	2SK211-GR	2	SMD; Q105.106
875-314489	2200482Y(IC IF)	TK14489V	1	SMD; IC102
874-102630FA	2214605(IC PLL(DUAL))	BU2630F	1	SMD; IC6
875-905020SP	2217178(IC COMPANDER)	DBL5020V (SOP)	1	SMD; IC601
876-900001AA	2218051(IC E2PROM )	24LC16A(SOP-8)	1	SMD; IC4
874-178569AL	2218858 ( IC OTP)	EM78P569ALQJ	1	SMD; IC301
875-100324FL	2220185A(IC OP AMP)	KIA324F-EL	1	SMD; IC2
875-907042SO	2220239A(IC VOLT. DETECTOR)	KIA7042AF	1	SMD; IC1
874-114066BD	2232249(IC)	MC14066BDR2G	1	SMD; IC602
882-590251SA	2420246(DIODE)	KDV251S	2	SMD; D402.403
882-190226AA	2430494(DIODE SWITCHING)	KDS226	1	SMD; D101
882-190184SA	2430515(DIODE SWITCHING)	KDS184S	11	SMD; D1.2.3.103.104.111A.122.154.203.301.302

Created by:	Approved by:	Rev.No:
For Stage:	Release Date:	Page: 40 / 55





Model No: 3419	Model No: M-795 Power	Drawing No:
Customer :		Rev,Date:

82-190181SA	2430636(DIODE SWITCHING)	KDS181S	1	SMD; D413
932-555418AB	411418B ( PCB MAIN M-795 )	148 X 166 X 1.6T	1	SMD;
501-400022AB	4A1221B ( PCB ASSY M-795 )	183 X 150 X 1.6T	1	SMD;
932-555273AB	411273B ( PCB ROTARY M-795 )	13.9 X 18.7 X 1.6T	1	SUB;
932-555343AB	411343B ( PCB LCD M-795 )	130 X 30 X 1.6T	1	SUB;
932-555844AB	411844B ( PCB VOLUME M-795 )	28 X 16.5 X 1.6T	1	SUB;
501-400028AB	53008MPM(MP MANUAL ASSY)	MP MANUAL ASSY	1	
911-322027JH	0182205X(RES. METALOXIDE)	22 1W 5% ST	1	MAN; R237
911-387017LH	0194798W(RES.METALOXIDE)	4.7 2W 5% ST	1	MAN; R207A
911-347017LH	0194798X(METAL OXID RESISTOR)	4.7 2W 5% ST BULK	1	MAN; R207
911-110027GH	0301006Z(RES. FILM)	10 1/2W 5% ST MINI	2	MAN; R43.225
911-122017GH	0302290Z(RES. FILM)	2.2 1/2W 5% ST MINI	1	MAN; R14
911-147037GH	0304711Z(RES. FILM)	470 1/2W 5% ST MINI	1	MAN; R26
911-147047GH	0304722Z(RES. FILM)	4.7K 1/2W 5% ST MINI	1	MAN; R315
911-147027GH	0304793Z(RES. FILM)	4.7 1/2W 5% ST MINI	1	MAN; R312
884-190006AA	0982012(THERMISTOR DISK)	200 15% KC5B120L	3	MAN; TH1.201.105
884-190010AA	0985013(THERMISTOR DISK)	500 KC5C150L	1	MAN; TH55
915-121005HKAD	1001019Y(CAP. ELECT)	0.1UF 50V 20% 5X11 T2.5pt	5	MAN; C13.31.39.433.605
915-121006HKAC	1010062Y(CAP. ELECT)	1UF 50V 20% 5X11 T2.5pt	4	MAN; C59.153.448.452
915-121007CKAB	1010435Z(CAP. ELECT)	10UF 16V SRA(M) 4X7 T2.5pt	17	MAN; C9.25.32.33.134.205.232.235.239.436.461.466.467.468.502.601.610
915-121009CKAF	1011179(CAP. ELECT)	1000UF 16V 20% 10X16 T5.0pt	2	MAN; C11A.72
915-121008CKZZ	1011223(CAP. ELECT)	100UF 16V 20% 6.3X11 T5.0pt	2	MAN; C228.237
915-12207AA	1022104Z(CAP. ELECT)	22UF 16V 20% 5X11 T2.5pt	1	MAN; C18
915-122206HKAB	1022412Y(CAP. ELECT)	2.2UF 50V 20% 4X7 T2.5pt	2	MAN; C603.608
915-122208FKAE	1023013(CAP. ELECT)	220UF 35V 20% 8X12 T5.0pt	4	MAN; C14.212.216.233
915-123306HKAB	1033393T(CAP. ELECT)	3.3UF 50V 20% 4X7	2	MAN; C107.108
915-124707CAAD	1047714X(CAP. ELECT)	47UF 16V 20% 5X11 T2.5pt	2	MAN; C206.437
915-124708CKAE	1048139X(CAP. ELECT)	470UF 16V 20% 8X12 T3.5pt	2	MAN; C213.702
915-124706EKAB	1048250(CAP. ELECT)	4.7UF 50V 20% 4X7	1	MAN; C12
913-114704AA	1304053X(CAP. CERAMIC DISK)	0.047UF SDD360Y5V473M50V	1	MAN; C201
913-111502AA	1315109X(CAP. CERAMIC DISK)	150PF NPO151K 50V	1	MAN; C2
913-113902HH	1339042(CAP. CERAMIC DISK)	390PF SL391K 50V	1	SUB; C339
913-114701HH	1347087X(CAP. CERAMIC DISK)	47PF NPO470K 50V	1	SUB; C71
917-112001AB	1720156W(TRIMMER DIP)	20PF CVN620	1	MAN; CT201
881-962314EA	2040167(TR)	2SC2314-E	1	MAN; Q303
882-215232BS	2412630(DIODE ZENER)	1N5232BST	2	MAN; DZ1.401
882-215237BA	2412632(DIODE ZENER)	1N5237BST	1	MAN; DZ201
882-315404AA	2450087X(DIODE RECTIFIER)	1N5404	1	MAN; D202
882-900001AA	2450153X(DIODE RECTIFIER)	1N4004	1	MAN; D531
928-130001BA	2604855V(CRYSTAL HC49U)	10.240MHZ -30 30PM 32P	1	MAN; X101
928-130001AF	2620439Y(CRYSTAL HC-49U)	4.5MHZ -30 30PPM 16PF	1	MAN; X901
928-130001AW	2634855(CRYSTAL OSCILLATOR)	32.768KHZ -10 20PPM 12.5PF	1	MAN; X1
929-310455HTAB	2700070X(FILTER CERAMIC)	LT455HT	1	MAN; CF101
929-300049TA	2710305Z(FILTER CRYSTAL)	HC49/T (10.695M)	1	MAN; XF101
918-900003AA	3001165(Transformer)	EI-19(CHOKE)	1	MAN; CH501
918-900012AA	TRANSFORMER	EI-28(6.7mH)	1	MAN; T201

Created by:	Approved by:	Rev.No:
For Stage:	Release Date:	Page: 41 / 55



Model No: 3419	Model No: M-795 Power	Drawing No:
Customer :		Rev,Date:

919-220001AA	3100226Z(COIL RF CHOKE)	10UF CR5K-869538	1	MAN; L601
919-120001AD	3102912Z(COIL AXIAL)	6.8UH:TCEC-6R8K	2	MAN; L7.306
919-420225ZCAB	3102967Y(COIL SPRING)	0.8X6.0X5.5TR	1	MAN; L308
919-420110ZBAB	3102978Y(COIL SPRING)	0.8X2.5X7TR	1	MAN; L304
919-120001AEAA	3103018Z(COIL CHOKE)	6UH BOBBIN CORE +-20%	1	MAN; L201
919-120001AG	3103166(COIL AXIAL)	0.47UH:LAL03TBR47K	1	MAN; L3
919-490004AB	3104071Z(COIL SPRING)	0.6X5.0X13.5TR	3	MAN; L5.6.307
919-490005AB	3105364X(COIL SPRING)	4 X 0.45 X 12TR	3	MAN; L311.312.313
919-120001AL	3106217Z(COIL AXIAL)	1.5UH:CESS-1R5K	1	MAN; L100
919-490012YA	3122648Z(COIL SPRING)	0.5X4.0X5TR	2	MAN; L2.4
919-290001AC	3202762Y(COIL IFT DET )	R4251-AHK7-854462	1	MAN; L104
919-290359AA	3203187Z(COIL IFT)	Z73C-359	2	MAN; L301.302
919-290010AA	3205563U(COIL IFT)	10.7MHZ MAX RX	1	MAN; L103
919-990001AC	3205806X(COIL IFT)	16.5MHZ 82PF COIL VCO	1	MAN; L501
919-294251AA	3205840Z(COIL IFT)	R4251-AHK7-854461	1	MAN; L106
919-390073AA	3205851Z(COIL IFT)	27MHZ Z073I-1	1	MAN; L101
919-990002AA	3210952(COIL IFT)	27MHZ RX (7RC)	1	MAN; L102
925-740002AA	4207051Z(JACK DC)	TC38-078-01	1	MAN; J101
925-770001AA	4207263X(JACK MINIATURE)	FJ-2506 2.5MM	1	MAN; J102
937-901001AF	509110Z(COIL SPRING)	0.55X3.4RX6.5T	1	SUB; L314
501-900004AF	594083(CB BPF MODULE)	CB BPF MODULE ALAN-78 PLUS	1	SMD;
913-431002HG	1310270Y(CAP. CERAMIC CHIP)	100PF GRM40COG101J50V	2	SMD; C400.409
913-431502HG	1315297Y(CAP. CERAMIC CHIP)	150PF GRM40COG151J50V	3	SMD; C402.404.406
913-433301HG	1333062Y(CAP. CERAMIC CHIP)	33PF GRM40COG330J50V	1	SMD; C408
913-434701HG	1347221Y(CAP. CERAMIC CHIP)	47PF GRM40COG470J50V	3	SMD; C403.405.407
919-120001AL	3106217Z(COIL AXIAL)	1.5UH:CESS-1R5K	1	MAN; L404
919-490023ZA	3108233Z(CORE SPRING ASSY)	0.17UH 0.45X2.3RX5.5T	3	MAN; L401.402.403
932-555985AZ	411985(PCB SUB)	25.5X9.0X1.2 FR4 1/1	1	SMD;
923-111502AC	4270236(WIRE)	1007 AWG 24 (11/0.16) RED	0.06	SUB; SW --- PCB MIC 0.5:0.5
923-111502AF	4270258(WIRE)	1007 AWG 24 (11/0.16) YEL	0.06	SUB; SW --- MIC(+) 0.5:0.5
923-111502AH	4270269(WIRE)	1007 AWG 24 (11/0.16) G	0.08	SUB; SW --- MIC(-) 0.5:0.5
501-900028WP	53008WMP(WIRE MAIN PCB ASSY)	WIRE MAIN PCB ASSY	1	
923-111502AN	4270456(WIRE)	1007 AWG 26(7/0.16) YEL	0.19	MAN; SPK(+) --- MP SPK(+) 0.5:0.5
923-111502AP	4270467(WIRE)	1007 AWG 26(7/0.16) GRN	0.19	MAN; SPK(-) --- MP SPK(-) 0.5:0.5

Created by:	Approved by:	Rev.No:
For Stage:	Release Date:	Page: 42 / 55



Model No: 3419

Model No:

Drawing No:

Customer :

M-795 Power

Rev,Date:

## Voltage Chart

### TRANSISTOR

Ref.	Pin	TX	RX	Ref.	Pin	TX	RX
Q1	E	0	0	Q104	E	0	0
KTC3876	C	0	0	KRC101	C	0	0
	B	0.8	0.6		B	0	0
Q2	E	0	0	Q105	G	0	0
KRC111	C	0	0.2	KTK211	S	0	1.14
	B	6.6	0		D	0	6.3
Q3	E	0	0.3	Q106	G	0	0
KRC104	C	0	0	KTK211	S	0	1
	B	3.2	0		D	0	6.3
Q4	E	0	0	Q107	E	0	0
KRC104	C	0	3.2	KTC3875	C	0	0
	B	6.8	0		B	0	0.6
Q6	E	0	0	Q112	E	0	1.5
KTC3880	C	2.5	2.5	KTC3876	C	0	0
	B	0.7	0.7		B	0	1.8
Q7	E	0	0	Q113	E	0	0
KTC3876	C	0	0	KTC3876	C	0	1.5
	B	0	0		B	0	0
Q8	E	0	3.15	Q114	E	0	0
KRC112	C	0	6.3	KRC101	C	0	0
	B	0	3.7		B	2.7	2.7
Q9	E	0	0	Q115	E	0	7.1
KRC104	C	7.8	0	KTA1504	C	0	7.1
	B	0	4.3		B	0	6.4
Q10	E	0	0	Q116	E	0	0
KRC104	C	0	0	KTC3880	C	0	6.8
	B	0	4.2		B	0	0.7
Q11	E	0.3	0.3	Q117	E	0	0.3
KTC3876	C	2.7	2.7	KTC3880	C	0	6.4
	B	0.9	0.9		B	0	1
Q102	E	0	1.4	Q118	E	0	0
KTC3880	C	0	7	KTA1504	C	0	0
	B	0	2.1		B	0	-0.5
Q103	E	0	0	Q202	E	0	0
KRC101	C	0	0	KRC102	C	0	0
	B	4.2	4		B	4.3	4.3

Created by:

Approved by:

Rev.No:

For Stage:

Release Date:

Page: 43 / 55



Model No: 3419

Model No:

Drawing No:

Customer :

M-795 Power

Rev,Date:

TRANSISTOR

Ref.	Pin	TX	RX	Ref.	Pin	TX	RX
Q204	E	0	0	Q304	E	0	0
KTC3876	C	0.3	0.3	2SC2078	C	12	4.5
	B	0	0		B	0	0
Q205	E	3.6	0	Q403	E	0	0
KTA1504	C	0	0	KRC101	C	0.3	0.3
	B	3	0.2		B	0	0
Q207	E	0	7	Q404	E	0	0
KTC3876	C	8	8	KRC101	C	0	0
	B	4.3	0		B	4	4
Q208	E	8	8	Q405	E	0	0
KTA1504	C	7.8	0	KRC101	C	0.3	0.3
	B	7.1	7.8		B	0	0
Q211	E	8	8	Q406	E	0	0
KTC3876	C	11.2	12.39	KRC101	C	0	0.5
	B	8.7	8.7		B	7.8	0
Q212	E	6.7	1.4	Q408	E	0	0
KRC102	C	10.8	12.4	KTC3880	C	7	7
	B	7.8	0		B	4.8	4.8
Q213	E	11.5	12.5	Q409	E	0	0
KTA1504	C	1.5	11.4	KTC3876	C	1.7	0
	B	10.7	12.4		B	0	0.7
Q214	E	12.3	12.9	Q411	E	0	0
KTB1367	C	11	1.4	KTC3880	C	3.5	3.5
	B	11	12.6		B	0.8	0.8
Q215	E	7.1	7.1	Q412	E	0	0
KTC3876	C	8	8	KTC3880	C	3.4	3.4
	B	7.8	7.8		B	0.7	0.7
Q301	E	1.2	0	Q415	E	5	5
KTC3880	C	8	0	KTC3876	C	12.8	12.8
	B	1.9	0		B	5.6	5.6
Q302	E	0.8	0	Q418	E	0	0
KTC3880	C	7.8	0	KRC101	C	0	0
	B	1.3	0		B	2.7	2.7
Q303	E	0	0	Q601	E	0.2	0.2
2SC2314	C	7.8	4.5	KTC3875	C	1.5	1.5
	B	0	0		B	0.8	0.8

Created by:

Approved by:

Rev.No:

For Stage:

Release Date:

Page: 44 / 55



Model No: 3419	Model No:	Drawing No:
Customer :	M-795 Power	Rev,Date:

TRANSISTOR

Ref.	Pin	TX	RX	Ref.	Pin	TX	RX
Q602	E	0	0	Q603	E	0	0
KRC104	C	0	0	KTC3875	C	4	4
	B	4.3	4.3		B	0.8	0.8

DIODE

Ref.	Pin	TX	RX	Ref.	Pin	TX	RX
D1	A	0	0	D122	A	0	3.6
KDS184	K	0	0	KDS184	K	0.7	3.1
D2	A	3.6	0	D154	A	7.2	0
KDS184	K	4.3	4.3	KDS184	K	7.8	0
D3	A	0	1.3	D203	A	3	0
KDS184	K	2.2	1	KDS184	K	9	4.4
D4	A	5	5	D301	A	0	0
KDS184	K	4.3	4.3	KDS184	K	5.8	0
D5	A	2.5	0	D302	A	7.7	0
KDS184	K	2.2	1	KDS184	K	7	0.5
D56	A	0	3.6	D303	A	0	7
KDS184	K	0	3.1	KDS184	K	0	6.4
D101	A	0	0	D402	A	0	0
KDS184	K	0	0	KDV251	K	5	5
D102	A	0	0	D403	A	0	0
KDS184	K	0	0	KDV251	K	0	0
D103	A	0	0	D407	A	1.6	0
KDS184	K		0	KDS184	K	4.3	0
D104	A	0	6.8	D413	A	0	0
KDS184	K	0	6	KDS184	K	0	0
D111	A	0	-2.6	D414	A	0	0
1N60	K	0	0	KDS184	K	0	0

Created by:	Approved by:	Rev.No:
For Stage:	Release Date:	Page: 45 / 55



Model No: 3419	Model No:	Drawing No:
Customer :	M-795 Power	Rev,Date:

DIODE

Ref.	Pin	TX	RX	Ref.	Pin	TX	RX
DZ201	A	0.3	0.3	D202	A	10	1
1N5237	K	8.7	8.7	1N5404	K	9.2	2.5
DZ401	A	0	0	D531	A	0	0
1N5232	K	5.6	5.6	1N4004	K	13	13

IC 102 TK14489

PIN	TX	RX	PIN	TX	RX
1	0	0	11	0	0
2	0	6.2	12	0	3.6
3	0	0	13	0	0.4
4	0	5.4	14	0	0
5	0	6.8	15	0	2.2
6	0	1	16	0	0
7	0	1	17	0	0
8	0	1	18	0	6.3
9	0	6.8	19	0	0
10	0	6.8	20	0	1.4

IC6 BU2630F

PIN	TX	RX	PIN	TX	RX
1	1.7	1.7	9	0	0
2	0	0	10	0	0
3	0.2	0.2	11	4.7	4.7
4	0	0	12	0.2	0.2
5	0	0	13	0.3	0.3
6	0	0	14	1.3	1.3
7	0	0	15	5	5
8	0	0	16	2.1	2.1

Created by:	Approved by:	Rev.No:
For Stage:	Release Date:	Page: 46 / 55



Model No: 3419

Model No:  
M-795 Power

Drawing No:

Customer :

Rev,Date:

IC601 DBL5020V

PIN	TX	RX	PIN	TX	RX
1	1.2	1.2	8	2.3	2.3
2	1.3	1.3	9	2.3	2.3
3	0	0	10	2.3	2.3
4	2.4	2.4	11	2.3	2.3
5	2.4	2.4	12	0.5	0.5
6	3	3	13	1.3	1.3
7	0	0	14	4.7	4.7

IC103 KIA7212

PIN	TX	RX	PIN	TX	RX
1	12.3	12.9	6	3	3.2
2	11	11.9	7	3	3.2
3	3.7	3.8	8	1.2	0.8
4	7.4	7.7	9	0	0
5	1.4	1.4	10	6.2	6.5

Created by:

Approved by:

Rev.No:

For Stage:

Release Date:

Page: 47 / 55



Model No: 3419

Model No:  
M-795 Power

Drawing No:

Customer :

Rev,Date:

IC101 S3P8249XZZ-TWR9

PIN	TX	RX	PIN	TX	RX
1	4.3	4.3	41	4.3	4.3
2	0.7	0.7	42	0	0
3	0.7	0.7	43	4.8	4.8
4	4.3	4.3	44	4.4	4.4
5	4.3	4.3	45	0	0
6	0	4.3	46	1	1
7	4	4	47	2.6	2.6
8	0	0	48	1.5	1.5
9	0	0	49	3	3
10	4.3	0	50	4.5	4.5
11	4	4	51	2.2	2.2
12	4.4	4.4	52	2.2	2.2
13	0	0	53	2.2	2.2
14	2.2	2.2	54	2.2	2.2
15	2.1	2.1	55	2.2	2.2
16	0	0	56	2.2	2.2
17	0	0	55	2.2	2.2
18	4.3	4.3	58	2.2	2.2
19	4.3	4.3	59	2.2	2.2
20	4.3	4.3	60	2.2	2.2
21	0	0	61	2.2	2.2
22	0	0	62	2.2	2.2
23	0	0	63	2.2	2.2
24	0	0	64	2.2	2.2
25	4.7	4.7	65	2.2	2.2
26	4.3	0	66	2.2	2.2
27	4.3	0	67	2.2	2.2
28	0	0	68	2.2	2.2
29	0	0	69	2.2	2.2
30	0	0	70	2.2	2.2
31	4.3	4.3	71	2.2	2.2
32	4.3	4.3	72	2.2	2.2
33	4.3	4.3	73	2.2	2.2
34	4.3	4.3	74	2.2	2.2
35	0	0	75	4.4	4.4
36	0	0	76	4.4	4.4
37	0	0	77	4.4	4.4
38	0	0	78	4.4	4.4
39	4.3	4.3	79	4.4	4.4
40	2.2	0	80	4.4	4.4

Created by:

Approved by:

Rev.No:

For Stage:

Release Date:

Page: 48 / 55





Model No: 3419

Model No:

Drawing No:

Customer :

M-795 Power

Rev,Date:

IC9 24LLC02A

PIN	TX	RX	PIN	TX	RX
1	0	0	5	0	0
2	0	0	6	4.3	4.3
3	0	0	7	0	0
4	0	0	8	4.3	4.3

IC2 KIA324

PIN	TX	RX	PIN	TX	RX
1	0	0	8	0	3.8
2	3.2	3.2	9	0	3.7
3	3.2	3.2	10	0	3.7
4	7.9	7.9	11	0	0
5	3.8	3.8	12	0	0
6	3.8	3.8	13	0	3.7
7	3.8	3.8	14	0	0

IC1 KIA7042F

PIN	TX	RX	PIN	TX	RX
1	5	5	3	4.4	4.4
2	0	0	-	-	-

IC602 MC14066BDR2

PIN	TX	RX	PIN	TX	RX
1	0	0	8	0.3	0.3
2	0.8	0.8	9	0.5	0.5
3	0.8	0.8	10	0.3	0.3
4	0.8	0.8	11	0.2	0.2
5	4.3	4.3	12	4.3	4.3
6	0	0	13	0	0
7	0	0	14	5	5

Created by:

Approved by:

Rev.No:

For Stage:

Release Date:

Page: 49 / 55

Model No: 3419

Model No:  
M-795 Power

Drawing No:

Customer :

Rev,Date:

## SEMICONDUCTOR LEAD IDENTIFICATION AND IC INTERNAL CONNECTIONS

### INTERATED CIRCUITS

IC101 : S3P8249XZZ-TWR9

IC102 : TK14489

IC9 : 24LLC02  
8 PIN

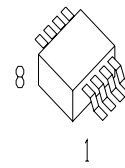
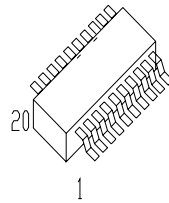
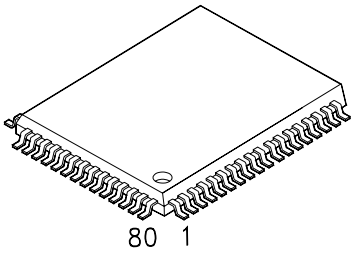

IC104 : KIA7217A

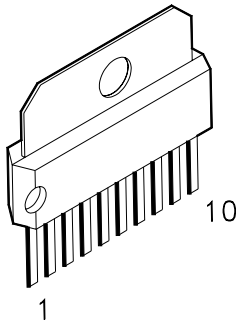

### DIODES

1N4004 .1N60 .1N5232  
1N5404 .1N5237

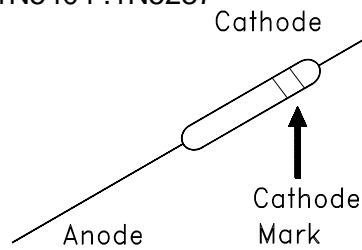

KDV251

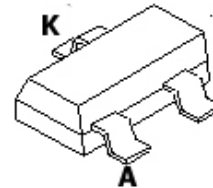

### TRANSISTORS

KTK211

KRC101S, KRC110, 2SC2314  
KTC3876, KTC3880  
KTC3875,3880  
KRC101~104

2SC2078,KTB1367

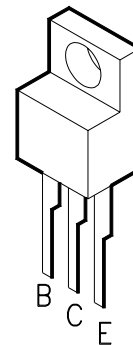
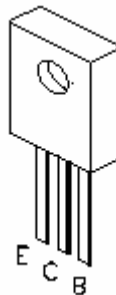
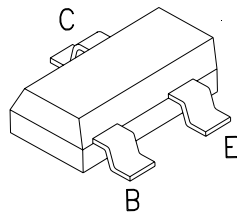
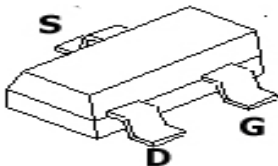

Created by:

Approved by:

Rev.No:

For Stage:

Release Date:

Page: 50 / 55

Model No: 3419

Model No:  
M-795 Power

Drawing No:

Customer :

Rev,Date:

KDS184

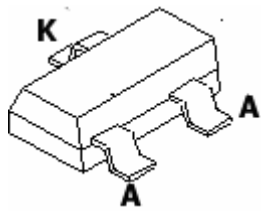

MC14066BDR2  
KIA324  
DBL5020V

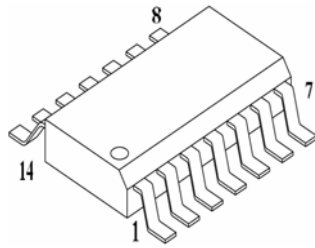

BU2630F

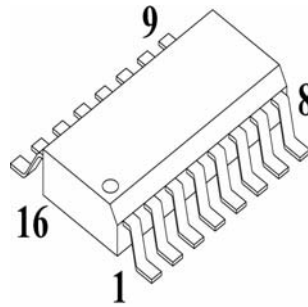

IC1 KIA7042F

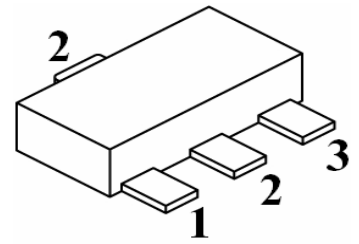

IC104 KIA7217A

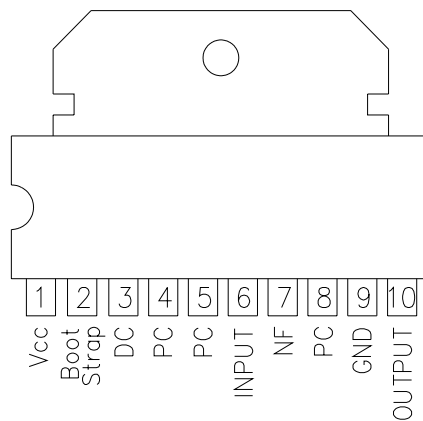

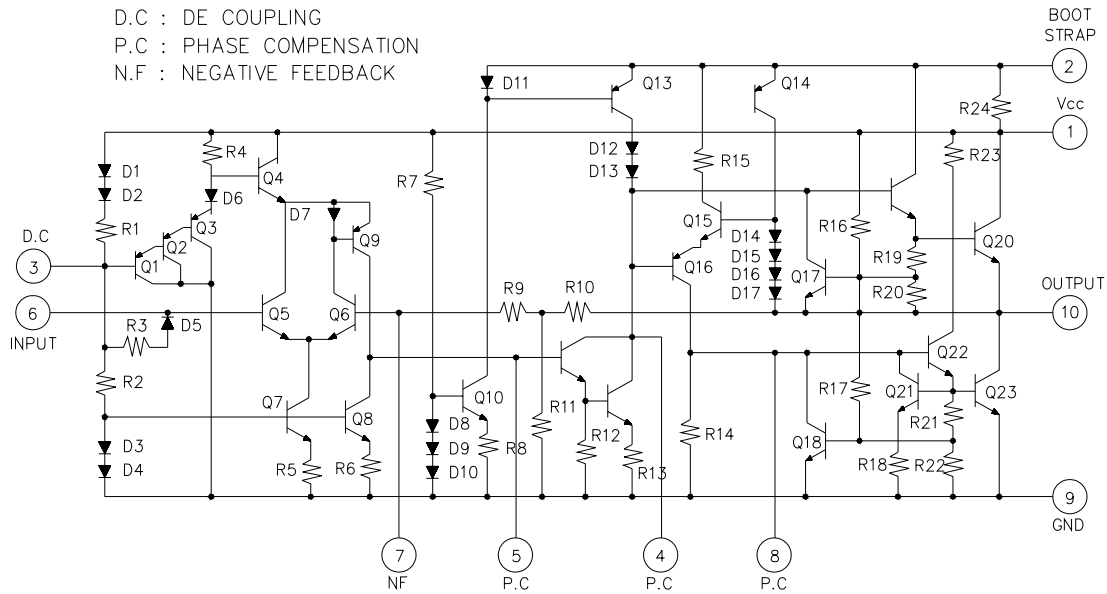



Model No: 3419

Model No:

Drawing No:

Customer :

M-795 Power

Rev,Date:

**Model M-790 Explode view (Part list)**

NO.	Part No.	Part name & Description	Q'ty	Ref.	Remark
1.	633-082	(+)TAP TITE SCREW BH3X6 BLK	7	COVER WITH	
2.	633-152	(+)TAP TITE SCREW BH3X4-3S BLK	2	UP.COV.+MAIN	
3.	719-062-A	COVER BOTTOM SECC+PVC T0.75	1		
4.	719-063-I	UPPER COVER SECC+PVC T0.75	1		
5.	730-015-A	HOLDER(SPK) EGI T1 USCOATING	3		
6.	891-590	CUSHION 25X25XT5 RUBB.SP0.BLK STI	1		
7.	901-226	FELT &65XT0.3 FELT BLK	1		
8.	611-095	(+)MACHINE SCREW(FH)2.6X5 ZN-PLAT	4		
9.	621-131	(+)TAPPING SCREW(BH)2.6X6-2S ZN-PLAT	2		
10.	834-501165AB	E.S.C ABS94HB L380-9001 BLK	1		
11.	834-501199BB	LENS ACRYL CLEAR	1		
12.	834-501217BB	KNOB VOL ABS 94HB BLK	2		
13.	834-501218BB	KNOB CH ABS 94HB BLK	1		
14.	896-403	KEY PAD"A" SILICONE RUBBER HS60'	1		
15.	896-414	KEY PAD "B" SILI RUBB RED/GRAY/BLUE	1		
16.	907-561	DOUBLE TAPE 3M 9448HK T0.16	1		
17.	613-332	(+)MACHINE SCREW(BH)3X10 ZN-PLAT	3		
18.	623-265	(+)TAPPING SCREW(BH)3X6-2S ZN-PLAT	4		
19.	651-024	NUT SS41 M3-1S ZN-PLAT	3		
20.	662-305	WASHER (SPRING) M3 ZN-PLAT	3		
21.	702-425-D	BODY MAIN EGI US COATING T1.0	1		
22.	719-119-A	HOUSING LCD PC 141 WHT (ALAN-78PLUS)	1		
23.	723-968	BRACKET LCD SPT0 T0.3	1		
24.	732-560	HOLDER(ANT MTG) SPT0 T0.3	1		
25.	750-039-A	CORD STOPPER P.P BLK	1		
26.	760-705	HEAT SINK ALP3 T2	1		
27.	795-697	PLATE BACK PC T0.5	1		
28.	853-105	BUSHING NYLON66+GLASS	2		
29.	895-682	ZEBRA SILICONE RUBBER HS65'	1		
30.	901-794-A	FELT 8X45XT0.3 FELT STIC.ALAN4	1		
31.	771-525	SHIELD HOUSHING SPT0 T0.3	1		
32.	771-710-A	SHIELD PLATE SPT0 T0.3	1		
33.		LABEL NAME POLYESTER 40 X 27 X T0.	1		
34.	420-128-4Z	SPEAKER NP-250-2 8 OHM 2W 66MM	1		
35.	202-066-2	TRANSISTOR KTB1367	1	Q214	
36.	204-010-1	TRANSISTOR 2SC2078(E)	1	Q304	
37.	222-006-4	I.C KIA7217AP	1	IC103	
38.	420-705-1Z	JACK DC TC38-078-01	1	J101	
39.	420-726-3X	JACK MINIATURE FJ-2506 2.5MM	1	J102	
40.	421-046-7	CONNECTOR CH-239(A) SW-1229	1	J103(ANT)	
41.	421-643-6A	CONNECTOR SOCKET SCN-16-6(M1)R PCB TYPE	1	J105(MIC JACK)	
42.	430-049-8Y	SW ROTARY YPS210120SK	1	SW105	
43.	440-020-4	MICA 0.1T:15X13 MICA FOR TR	1		
44.	450-436-4Z	VARIABLE RESISTER CSPNS-0906-15SP-A10K	1	VR102	

Created by:

Approved by:

Rev.No:

For Stage:

Release Date:

Page: 53 / 55



Model No: 3419

Model No:

Drawing No:

Customer :

M-795 Power

Rev,Date:

45.	450-437-5W	VR	RV0915N-15KQA1-B10K-A	1	VR1	
46.	251-162-5Z	LED LAMP	LTL-81HGK	2	B104.105	
47.	251-224-8Z	PILOT LAMP	60MA 3& 14V	3	B101.102.103	
48.	251-286-4Z	LAMP LED	L-115 VEGW	1	LED1	
49.	252-324-7	LCD DISPLAY	IS05228E	1	LCD1	
50.	436-059-7Z	SW TACT	TM115AP	6		
51.	504-892	MOLEX PLUG ASS'Y		1		
52.	932-557418AB	P.C.B LCD	130 X 30 X 1.6T	1		
53.	932-557273AB	P.C.B VOL	28 X 12.5 X 1.6T	1		
54.	932-557343AB	P.C.B ROTARY	13.9 X 14.4 X 1.6T	1		
55.	932-557844AB	P.C.B MAIN	148 X 166 X 1.6T FR4 2/S	1		
56.	832-501226AA	HEAT SINK		1		
57.	832-501227AA	SINK L		1		

Created by:	Approved by:	Rev.No:
For Stage:	Release Date:	Page: 54 / 55

# INTEK

Model No: 3419

Model No:

M-795 Power

Drawing No:

Customer :

Rev,Date:

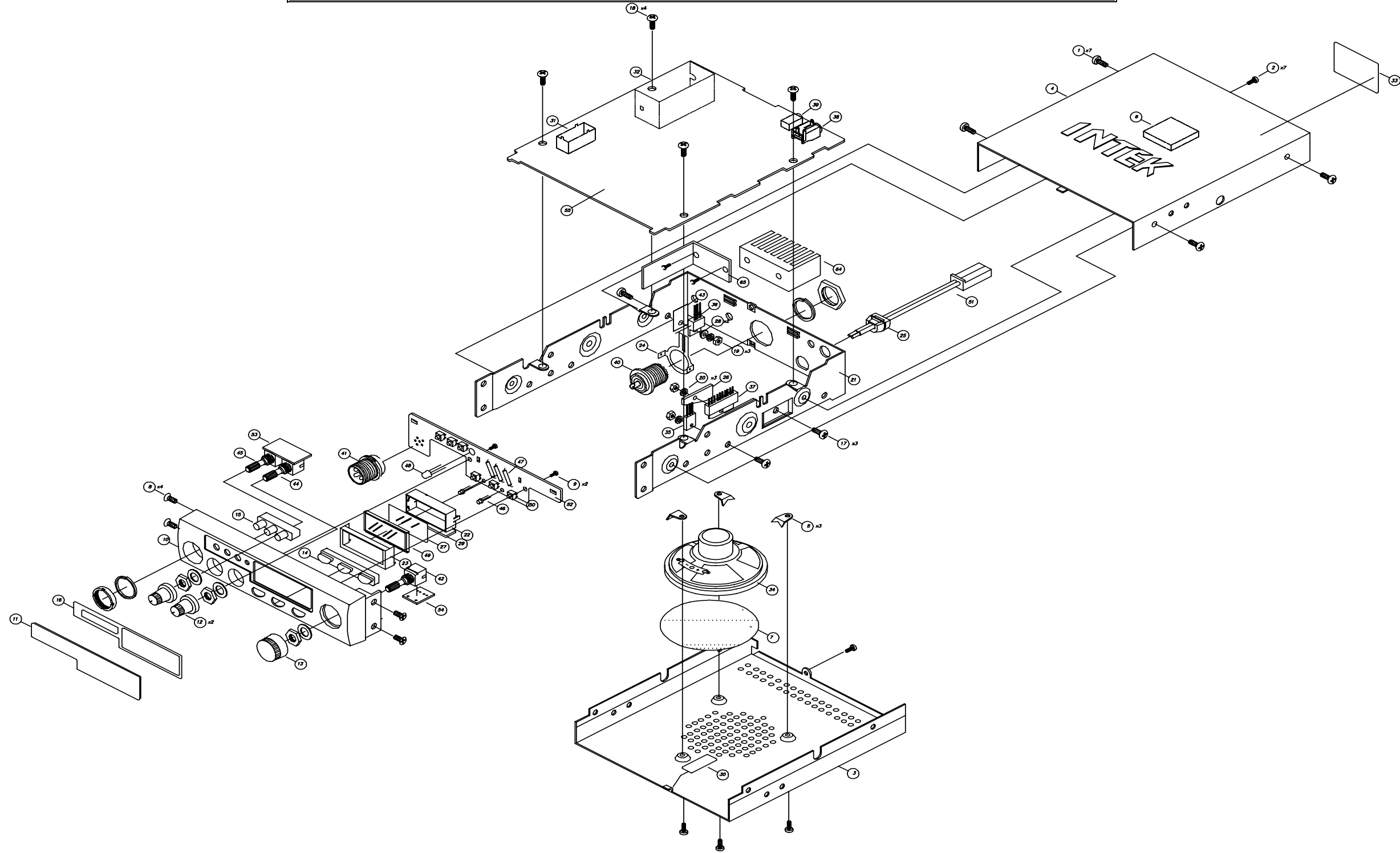

Created by:

Approved by:

Rev.No:

For Stage:

Release Date:

Page: 55 / 55