

# SIRIO 2000 series

## 26.4...28.2 MHz Tunable Base Station Antennas

### DESCRIPTION

Hi-quality base station antennas tunable from 26.4 to 28.2 MHz. They are made of anti-corodal aluminium tubes and supplied with polythene jointing sleeves to guarantee a perfect waterproofing. Strong and easy to install, they allow very good links.

### SPECIFICATIONS

#### Electrical Data

Type	: 5/8 $\lambda$ Ground Plane
Frequency range	: 26.4...28.2 MHz tunable (see table)
Impedance	: 50 $\Omega$
Radiation (H-plane)	: 360° omnidirectional
Polarization	: Linear Vertical
Gain	: 1.3 dBd, 3.45 dBi
Bandwidth @ SWR $\leq 2$	
SIRIO 2008, SIRIO 2012	: $\geq 1750$ KHz
SIRIO 2016	: $\geq 2100$ KHz
SWR @ res. freq.	: $\leq 1.1$
Max Power	: 1000 Watts (CW) continuous : 3000 Watts (CW) short time
Feed system/ position	: Transformer DC-ground / base
Connector	: UHF-female

#### Mechanical Data

Materials	: Aluminium, Copper, Nylon Brass, Galvanized Steel
Wind Load / Resistance	: 166 N @ 150Km/h / 130 Km/h
Wind surface	: 0.14 m <sup>2</sup>
Length (approx.)	: 6100 mm
Weight (approx.)	: 5300 gr
Radial lenght	
SIRIO 2008, SIRIO 2012	: 1320 mm
SIRIO 2016	: 700 mm
Mounting Mast	: $\varnothing$ 40-50 mm

#### HIGH POWER IMPEDANCE TRANSFORMER

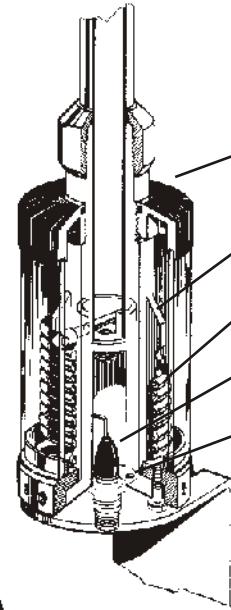

#### Construction details:

- Coil cover made of transparent anti-shock material.
- Low loss coil support with finger spacers.
- $\varnothing$  75mm coil made of  $\varnothing$  4.5mm copper wire.
- UHF-female connector with protection cap.
- Discharge holes for possible condensations.

TYPICAL S.W.R. RESPONSE

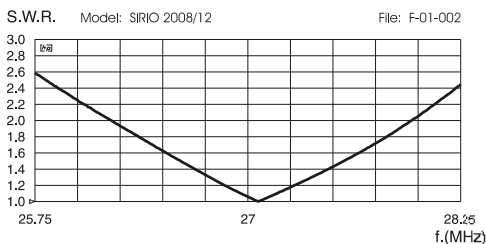

TYPICAL S.W.R. RESPONSE

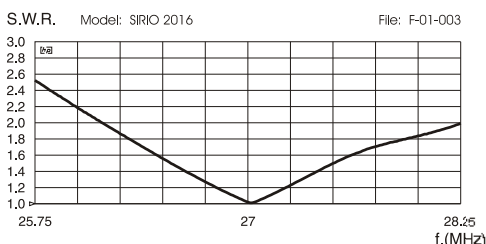

#### SIRIO 2000 series features:

- SIRIO 2008 : with 8 G.P. radials lenght=1320mm
- SIRIO 2012 : with 12 G.P. radials lenght=1320mm
- SIRIO 2016 : with 16 G.P. radials lenght= 700 mm

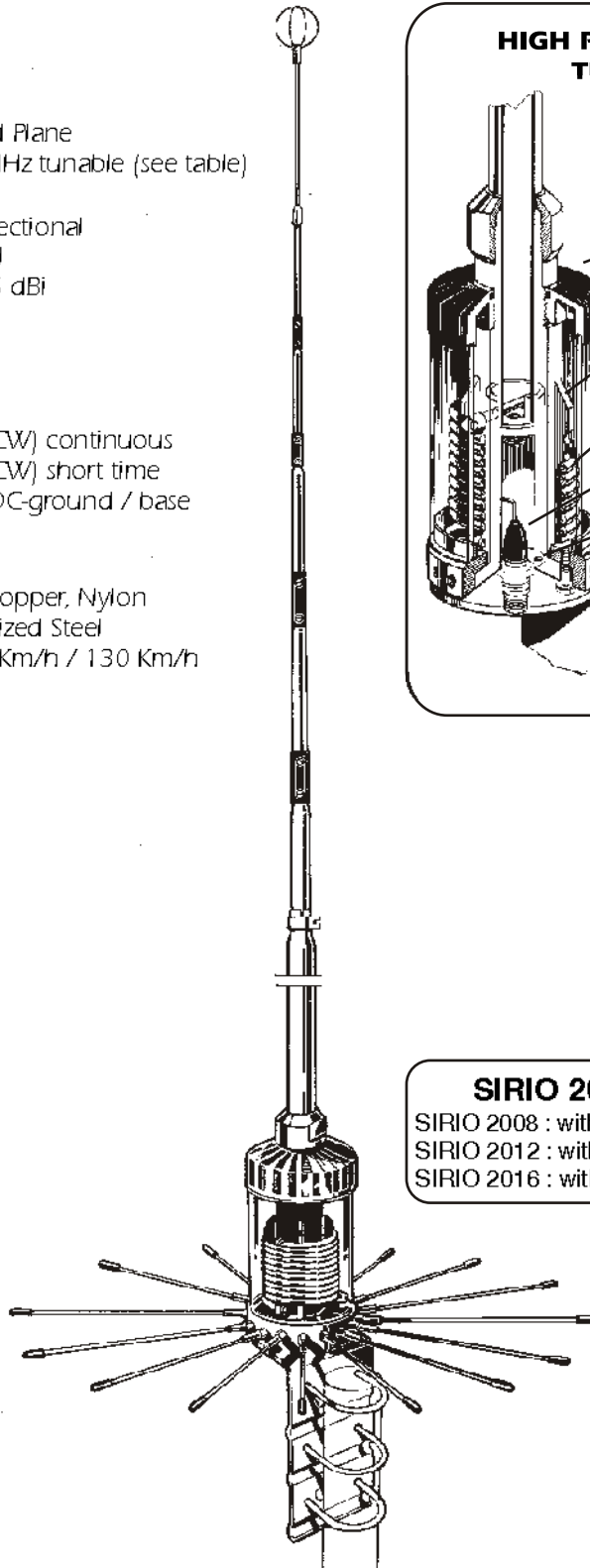

TUNING TABLE	
Freq. (MHz)	L (mm)
26.4	545
27.0	381
27.185	330
27.5	241
28.0	101
28.2	45

Mounting needed tools:	
n. 1	tape rules (meter)
n. 1	phillips screwdriver
n. 1	8 mm open key
n. 1	10 mm open key
n. 1	13 mm open key

Parts List		
Pos	Q.ty	Description
1	1	5 sections telescopic aluminium whip
2	4	plastic jointing sleeves (4 different sizes)
3	8	Ø 3.9x6.5 mm phillips tapping screws
4	1	top section with cage
5	1	M4x4 hexagon socket set screw cup point
6	1	2 mm hexagonal key
7	1	Bottom section assembled with coil and connector
8	6	M8 washers
9	6	M8 spring lock washers
10	6	M8 hexagonal nuts
11	3	M8x200 mm U-bolts
12	1	Ø 26-28 mm hose clamps
13	8/12 16	Ø 6x8x1320mm radials aluminium tubes with joint (SIRIO 2008/12) Ø 6x8x700mm radials aluminium tubes with joint (SIRIO 2016)
14	8/12/16	PVC cap for Ø 8mm aluminium tubes (models dependent)

### MOUNTING INSTRUCTIONS

**1**

Pull out the sections of telescopic aluminium whip (1), insert the jointing sleeves (2) and lock them using the screws (3). Insert the top section with the cage (4) at L (see tuning table for frequency) and lock it using the screw (5) and 2 mm hexagonal key (6).

**NOTE:** Use the table just as a guide. For fine-tuning please use an SWR-meter

**2**

Fit the whip (1) on the bottom section (7). Well lock the hose clamps (12) by using the suitable 8mm open key.

**3**

Mount the bottom section with coil (7) on the mast using parts (8), (9), (10) and (11) in accordance to the picture.

Mast Ø 40-50mm (not supplied)

**4**

Mount the PVC cap (14) at the end of radials tubes (13) and lock them on the coil by using the suitable 10mm open key.