

YAESU YS-500

IN-LINE WATTMETER & SWR BRIDGE
FOR 140 - 525 MHz

The YS-500 is a handsome compact measuring instrument which provides a convenient means for monitoring both average and peak transmitter power output and reflected power, and voltage standing wave ratio (VSWR) of antenna systems in two-way VHF and UHF radio stations. The small size and color-coordinated housing make this an ideal addition to any Yaesu transceiver, for transmitter power levels from 0 to 200 watts (at least 4 watts required for accurate SWR readings). Three functions provide monitoring of either forward or reflected average transmitter output power for CW, AM, FM and FSK modes, or peak envelope power (PEP) for SSB modes, and VSWR for testing and monitoring the performance of transmitting antenna systems. The efficient, linear circuit design assures accurate measurements with less than 0.2dB insertion loss over most of the specified frequency range.

Connections and Controls

(1) Meter

Five meter scales are provided, the lower three of which are marked for power measurements: 0 - 4, 0 - 20 and 0 - 200 watts, respectively. The upper scales are for SWR measurements, with the outermost for SWR measurements with power levels more than 20 watts, and the inner of these two scales for SWR measurements at power levels less than 20 watts.

(2) RANGE Selector

This 3-position lever switch selects the 4-, 20- or 200-watt power scale for average or PEP measurements.

(3) FUNCTION Selector

This 3-position lever switch selects POWER, CAL (calibrate, prior to swr measurement), or SWR (after calibration).

(4) CAL - AVG/PEP Knob

This knob serves two functions: pressing or pulling it selects AVG (average) or PEP (peak) power measuring modes, respectively; and, while in the depressed position, rotating it calibrates the meter for SWR measurements.

(5) POWER Selector

This 2-position lever switch selects forward (FWD) or reverse (REV) power measurement.

(6) Zero Adjustment

This slotted control should be adjusted so that the meter needle rests on the

"0" scale markers while the YS-500 has no power applied.

(7) TX Jack (indicated on label plate)

This type SO-239 coaxial jack accepts RF input directly from the transmitter, transceiver or RF power amplifier via short length of coaxial cable with type PL-259 plugs on each end.

(8) ANT Jack

This type SO-239 coaxial jack provides (measured) transmitter power to the antenna system. Note that the impedance of the antenna system at this point must be 50 ohms for proper operation, so an antenna matching unit, if used, should be connected between this jack and the antenna itself. A 50-ohm dummy load, if used, may also be connected here.

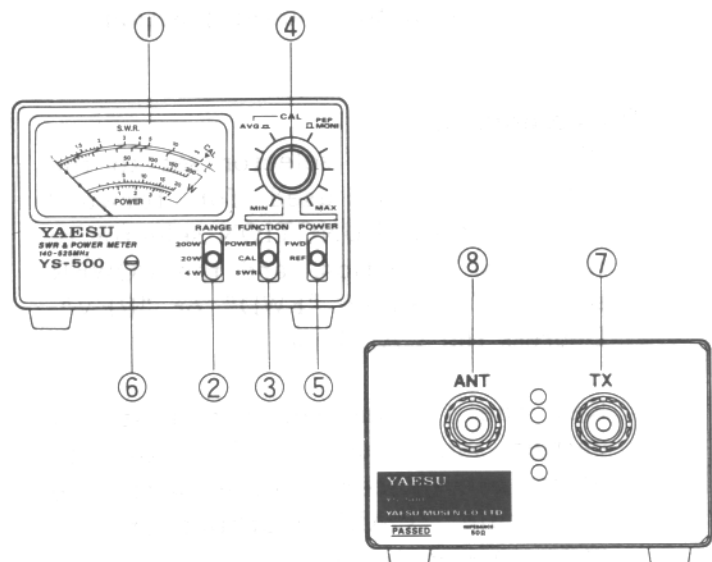

Forward Power Measurement

- (1) Set the selectors as follows;
 - RANGE to desired range (if unknown, select the highest possible range)
 - FUNCTION to "POWER" position,
 - POWER to "FWD" position,
 - CAL knob depressed ("AVG" position)
- (2) Activate the transmitter to send a steady carrier (do not use an SSB mode). If the meter indicates either too low or too high on the scale, select the adjacent RANGE. Read the average forward power output on the appropriate scale for the selected range.

- (3) For PEP measurement, pull the CAL knob out. The transmitter mode may now be set for SSB. Speak into the microphone normally and observe the meter for PEP forward power output, in watts.

Reflected Power Measurement

After setting up the selectors and measuring forward power as above, reflected power (average or PEP) can be measured by switching the POWER selector to the "REF" position. If the meter does not deflect enough for a good reading, move the RANGE switch to a lower position.

SWR Measurement

- (1) With the RANGE selector set to the same range as used for forward power, set the FUNCTION selector to the "CAL" position, and the POWER selector to either "FWD" or "REV". Depress the CAL knob.
- (2) Key the transmitter for a steady carrier, and adjust the CAL knob to align the meter needle with the full-scale "CAL" marking on the upper meter scale.

- (3) Move the FUNCTION selector to the lower ("SWR") position, and read the SWR on the appropriate meter scale (upper scale for forward power over 20W, second scale for power under 20W).

>>> CAUTION <<<<

Average transmitter power output should be limited to 150W (between 140 and 220 MHz) or 100W (between 220 and 525 MHz) if transmissions are to exceed 10 minutes in continuous duty modes (FM, FSK or key-down CW), to prevent damage to the bridge circuitry.

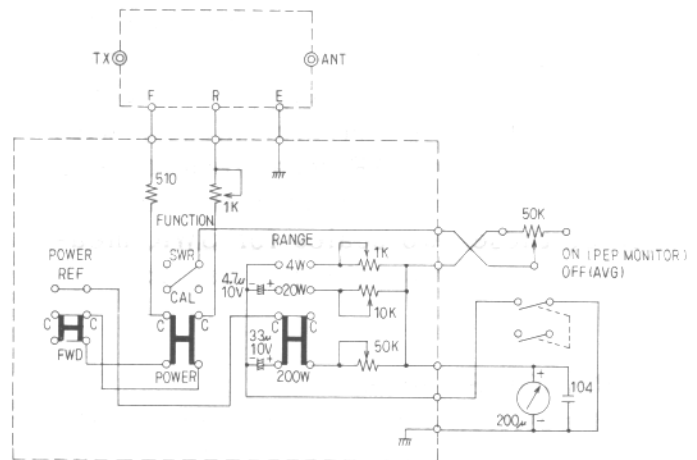

Specifications

Frequency Range	140 – 525 MHz
Measurable Power Range	0 – 200W
Meter Full Scale Ranges	4/20/200W
Power Meas. Accuracy	
4W Range:	±10% of full scale
20/200W Ranges:	±5% of full scale
Note: 220 - 420 MHz:	subtract 10% f/s
450 - 525 MHz:	add 10% f/s
Minimum Power for SWR meas.	4 watts
SWR Measuring Range	1.0:1 to infinity
Insertion Loss:	
140 - 250MHz:	less than 0.1dB
400 - 470MHz:	less than 0.2dB
525MHz:	less than 0.3dB
Input/Output Impedance	50 ohms
Input/Output Connectors	SO-239
Dimensions (WHD)	120 x 72 x 85mm
Weight	540g (19 oz.)