

INSTRUCTION MANUAL
for
THE
NATIONAL MODEL
HFS
RADIO RECEIVER

A superheterodyne, superregenerative
Receiver covering all frequencies from 27
to 250 megacycles.

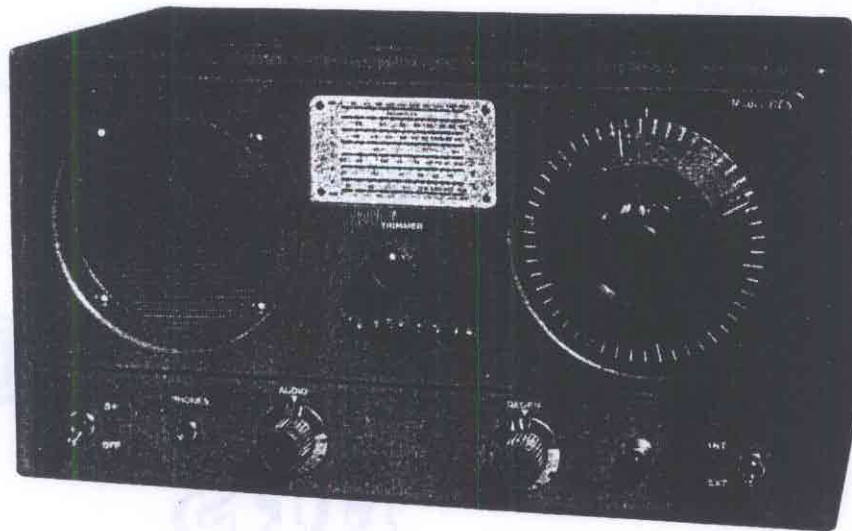

National



The HFS Receiver

HIGHLIGHTS

- VHF Receiver Covering Frequencies from 27 to 250 Megacycles
- Receiver or Converter Operation
- Efficient Superheterodyne-Superregenerative Circuit
- A.M., C.W. and F.M. Reception
- 10.7 Megacycle Converter Output
- Plug-in R.F. Coils
- Built-in Loud-speaker

National Company, Inc.

THE HFS RECEIVER

SECTION I. DESCRIPTION

1-1. General

The HFS is a seven tube, superheterodyne-superregenerative Receiver-converter having a continuous frequency coverage of from 27 to 250 megacycles. The HFS is especially designed to provide an efficient, all-around Receiver for the very high frequency range encompassing $1\frac{1}{4}$ through 11 meters. This Receiver is suitable for the reception of amplitude modulated signals, frequency modulated signals (by slope detection) and code telegraphy signals. The utility of the HFS is greatly increased by the Converter Output receptacle which is provided to permit use of the HFS as a high-frequency converter. In converter operation the HFS may be used ahead of a communication-type receiver or it may be used as the front end of an F.M. broadcast installation.

1-2. Circuit

A stage outline of the circuit employed in the HFS Receiver is given below together with the tube associated with each stage:

First Detector.....	6AK5
H.F. Oscillator.....	9002
I.F. Amplifier.....	6SG7
Second Detector.....	6SK7
First Audio.....	6J5
Audio Output.....	6V6GT/G
Converter Output.....	6J5

1-3. Tuning System

The two-gang main tuning capacitor, the panel-mounted TRIMMER capacitor and six sets of plug-in type R.F. coils are used to tune the frequency range of the Receiver in six tuning bands as follows:

BAND	FREQUENCY COVERAGE
A	178 - 250 Mc.
B	120 - 178 Mc.
C	80 - 120 Mc.
D	56 - 80 Mc.
E	41 - 60 Mc.
F	27 - 42 Mc.

The main tuning control is the National type PW-D micrometer dial reading directly from 0 to 500 having a linear scale

length of approximately 12 feet, requiring ten revolutions to cover any one band. This scale length plus the vernier action of the dial gives the operator the equivalent of continuous bandspread tuning on all bands. The chart on the front panel correlates dial reading and frequency for each band. It will be noted that frequency increases with dial reading.

1-4. Converter Output

The HFS may be used as a high frequency converter by connecting the 10.7 megacycle I.F. output, available at the Converter Output receptacle, J-2, to a suitable receiver tuned to 10.7 megacycles. The selectivity of the combination of the HFS and associated receiver will be essentially that of the more selective unit. In most cases the associated receiver will be the more selective. The HFS will also serve as the front end of a high fidelity F.M. broadcast (wide-band) installation if the converter output is connected to a 10.7 megacycle F.M. I.F. channel and suitable amplifier-loud-speaker system.

Two controls on the HFS are provided for use in converter operation:

1. The INTERNAL-EXTERNAL switch, S-2, in the External position connects the I.F. output to the output receptacle and renders inoperative the second detector and audio stages of the HFS.

2. The converter output control, R-14, adjusts the I.F. output of the Receiver when the INTERNAL-EXTERNAL switch is in the External position.

1-5. Audio Output

Two audio output circuits are provided:

1. The loud-speaker in the HFS is a 5 inch P.M. type. An output transformer is mounted on the loud-speaker to match the impedance of the output tube.

2. A Phones jack is mounted on the front panel and is wired so as to silence the loud-speaker when headphones are used. The headphone load impedance is not critical permitting the use of a wide range of

headphone types including crystal types.

1-6. Power Supply

The HFS Receiver is designed for operation from the National type 5886 Power Unit. The 5886 Power Unit operates from a 110/120 or 220/240 volt, 50/60 cycle source of supply. The 5886 delivers all voltages

required by the heater and B supply circuits--6.3 volts at 2.13 amperes and 180 volts at 38 milliamperes, respectively.

The HFS is adaptable to battery operation using the National type 686S battery powered vibrapack or direct from suitable batteries. See Section 2-3 for detailed instructions on battery operation.

SECTION 2. INSTALLATION

2-1. Installation Procedure

After the HFS Receiver and 5886 Power Unit are unpacked, proceed as outlined below. It is recommended that the HFS is not placed too close to the 5886 Power Unit, or any other power unit, to avoid the possibility of hum pick-up.

1. Make sure all tubes are seated firmly in their sockets.

2. Remove the desired R.F. coil set from the rack inside the Receiver and place the two coils in the proper sockets. All R.F. coils are stamped with a combination letter-number; the letter designating the band and the number the circuit position. The two R.F. coil sockets are stamped 1 and 2, respectively, to identify the circuit position and to correspond to the numerical marking on the coils. Make sure that the coils are pushed well down into their sockets, doing this, however, without exerting

undue force.

3. Connect the antenna as recommended in Section 2-2.

4. Insert the four prong power plug, W-1, into the receptacle provided on the 5886 Power Unit.

5. Connect the A.C. line cord on the 5886 Power Unit to the proper source of supply. The toggle switch, located on the under side of the Power Unit, selects the arrangement of the primary of the transformer for either 115 or 230 volt, 50/60 cycle operation. This switch is normally set at the 230 volt position and if the Power Unit is to be operated from a 115 volt supply the switch must be set at the 115 volt position.

6. Set controls as recommended in Section 3 for the reception of signals.

7. If the HFS is to be used as a converter, make a connection between the coaxial connector, J-2, at the rear of

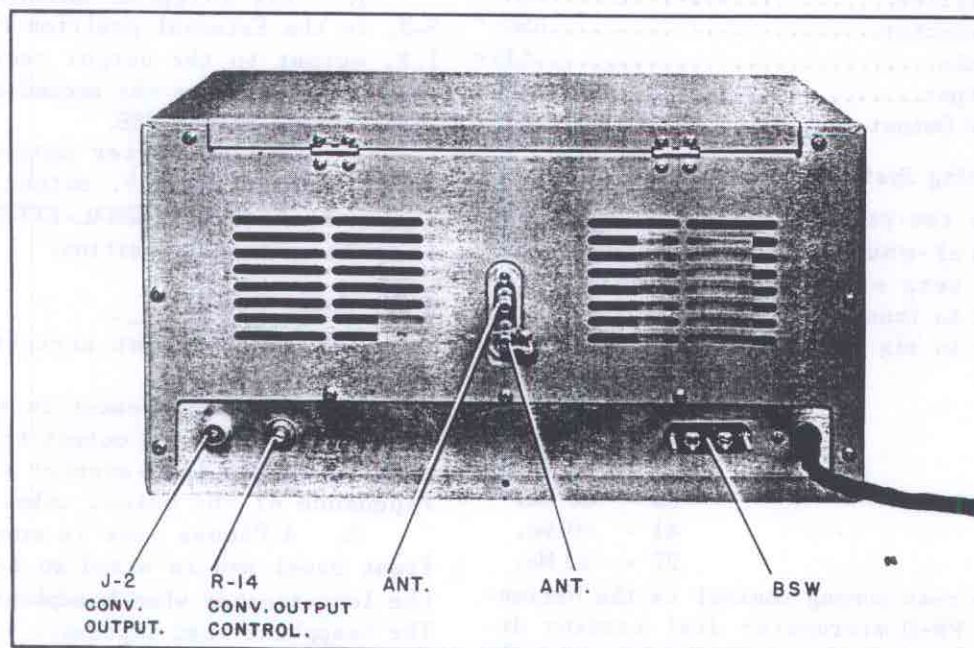

Figure No. 1. Rear View of Receiver (BSW Shield Removed)

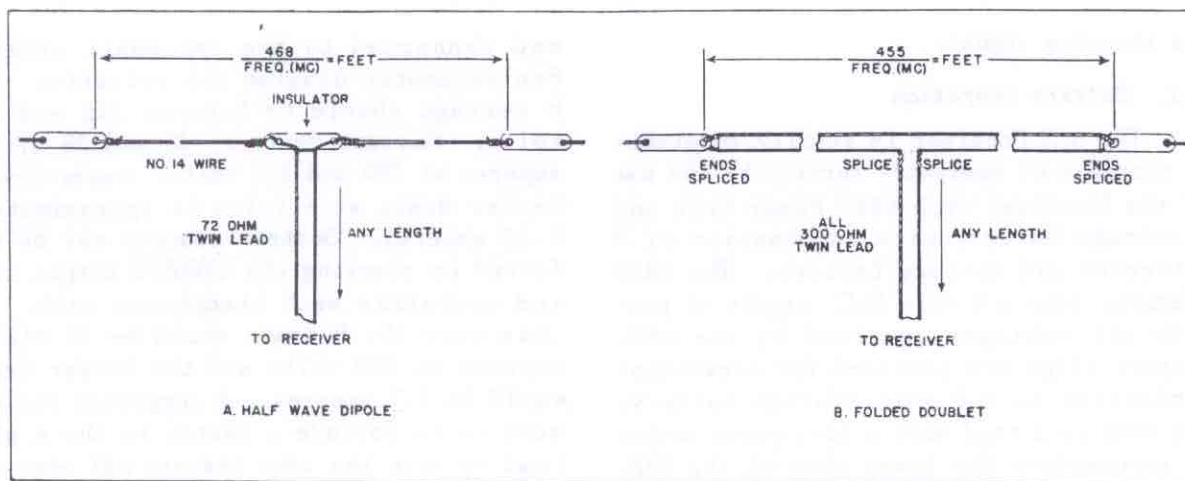

Figure No. 2. Suggested Antenna Types

the HFS and the associated apparatus. The Amphenol type 75-MC1F plug, or equivalent, mates with the converter receptacle on the HFS. The Amphenol type 21-147 cable, which is a single conductor type with a shield braid and an outside diameter of .195 inches, mates with the type 75-MC1F plug. In making the above connection the shield braid should be grounded at both termination points, making sure that the braid is securely fastened to the shell of the plug used on the HFS. The use of a shielded cable will minimize the possibility of stray pick-up at the I.F. frequency. It is advisable to keep the cable length as short as possible to further minimize any stray pick-up.

2-2. Antenna Recommendations

The importance of an efficient antenna for use with the HFS Receiver cannot be over emphasized. The antenna input circuit of the HFS is arranged for operation from doublet feeders or two-wire lines having impedances of between 70 and 300 ohms. Single-wire antennas may be used if it is desired to have an antenna providing coverage for an extended frequency range.

The two types of antennas shown on Figure No. 2 are suggested for use with the HFS. The drawing gives sufficient detail for the construction of either type of antenna. Determining the length of the antenna elements by use of the formula shown in Figure No. 2 will provide an antenna with good efficiency for the oper-

ating frequency or narrow band of frequencies. In an installation where the Receiver is to be used as the receiving unit in a transmitting station the most efficient operation will usually result from use of the transmitting antenna as the receiving antenna also. For switching the antenna from transmitter to Receiver, an antenna change-over relay with good high frequency insulation is recommended.

The methods of connecting the various types of antennas to the antenna posts at the rear of the Receiver are as follows:

1. Single-wire type--Connect antenna to the uppermost post and ground the unused post by means of the flexible braid attached to the chassis.
2. Doublet type--Connect the antenna feeders to the two antenna posts; the flexible braid is not used. Connecting the flexible braid to the adjacent antenna post may provide a reduction in the noise level in certain installations and its use should be determined by trial.
3. Concentric transmission line type--Connect the inner conductor to the uppermost antenna post and the outer conductor to the lower post and chassis by means of the flexible braid.

An improvement in reception can be obtained, no matter what the antenna type, by mounting the antenna in an unconfined area, preferably high enough to clear all surrounding objects. This is true especially on the higher frequencies, where even a tree may prove to be an obstruction to

the incoming signal.

2-3. Battery Operation

The HFS Receiver is readily adaptable to portable or emergency service by the use of the National type 686S Power Unit and a storage battery or a combination of B batteries and storage battery. The 686S operates from a 6 volt D.C. supply to provide all voltages required by the HFS. Battery clips are provided for convenient connection to a 6 volt storage battery. The 686S is fitted with a four-prong socket to accommodate the power plug of the HFS. To use batteries directly a 6 volt supply (storage battery) should be connected to the two large prongs on the power plug (heaters) and the plate and screen requirements should be obtained from B batteries

and connected to the two small prongs. See schematic diagram for polarity. The B voltage should be between 135 and 180 volts. Current drain is 38 and 28 milliamperes at 180 and 135 volts, respectively. Heater drain at 6 volts is approximately 2.13 amperes. Battery economy may be effected by removing the 6V6GT/G output tube and operating with headphones only. In this case the B drain would be 18 milliamperes at 180 volts and the heater drain would be 1.7 amperes. A suggested refinement is to include a switch in the A plus lead to turn the tube heaters off when the Receiver is not in use. The B plus switch is operative on battery operation.

The recommendations of Section 3, Operation, also apply to the battery powered HFS.

SECTION 3. OPERATION

3-1. Controls

The Main Dial is the tuning control. It drives a two-gang variable capacitor, C-5, to cover the frequency range of the receiver.

The REGENERATION control adjusts the plate voltage on the second detector to provide regeneration or superregeneration. The superregenerative condition, normally used for phone reception, provides excellent A.V.C. and noise limiting action. The regenerative non-oscillating condition takes place at a control dial setting of from 0 to 3; the regenerative oscillating condition takes place between 3 and 4; the superregenerative condition takes place from 4 to 10 on the control dial. When using the REGENERATION control it will be noted that the start of the regenerative-oscillating condition is indicated by a click and an increase in background noise; the superregenerative condition is indicated when the background noise becomes quite strong. For best results when using the HFS in the superregenerative condition, the REGENERATION control should be set at the control dial setting where the smoothest quieting action is obtained. The regenerative-oscillating condition produces an audio beat note necessary for the reception of C.W. signals.

The AUDIO control adjusts the output volume level of the Receiver. The volume level increases as the control is turned towards 10 on the scale.

The B plus switch is used to quiet the Receiver during transmission periods or when changing coils while permitting the heater circuits to remain closed. The Receiver is shut off by setting the A.C. switch on the Power Unit at off. The function of the B plus switch may be duplicated at an external (remote) position by connecting a switch or relay contacts to the terminals on the BSW panel at the rear of the Receiver. This is a parallel arrangement permitting the use of the panel-mounted B plus switch to turn the Receiver on, although the external switch is in the off position. It is recommended, when using B battery plate supply, that the B plus switch should be set at the Off position when the Receiver is not in use to avoid stand-by drain. The A battery should also be disconnected when the Receiver is not in use.

The TRIMMER control operates a variable trimmer capacitor which is connected across the first detector main tuning capacitor section. The TRIMMER control is used to tune the first detector stage properly under a wide variety of antenna loading conditions.

The INTERNAL-EXTERNAL switch, in the External position, connects the output of the I.F. amplifier stage to the converter output receptacle at the rear of the Receiver and renders inoperative the second detector and audio stages. The External position is used when the HFS is utilized as a converter ahead of auxiliary apparatus.

An output control with a screw-driver-type adjustment, is mounted at the rear of the HFS. This control is in the circuit, when the INTERNAL-EXTERNAL switch is at the External position, to adjust the amount of I.F. output available at the converter receptacle. The available output is increased as the control is rotated in a counter-clockwise direction.

3-2. Operating Instructions

After the equipment is installed, as outlined in Section 2, it is placed in operation for the reception of phone signals by adjusting the controls as follows:

1. Set the B plus switch at B plus.
2. Set the INTERNAL-EXTERNAL switch at Internal.
3. Set the AUDIO control at approximately 5 and readjust, as necessary, for the desired volume.
4. Set the A.C. switch on the Power Unit at On.
5. Set the REGENERATION control at a setting beyond the point where super-regeneration starts (about 4). After the signal has been tuned in, adjust the REGENERATION control for optimum reception. For the reception of weak signals, the regenerative-non oscillating condition may provide better reception.
6. Tune the Main Tuning dial to the

desired frequency.

7. Set the TRIMMER control at the point providing the maximum sensitivity. When operating in the superregenerative condition, the correct setting will be indicated by the maximum quieting action.

The procedure for the reception of C.W. signals is the same as that given above for phone reception except for the setting of the REGENERATION control. For C.W. reception set the REGENERATION control between 3 and 4, the oscillating condition. Strong C.W. signals will cause the Receiver to block and reception is not possible with the HFS blocked. For C.W. reception better results will be obtained if the HFS is used in converter operation ahead of a communication-type receiver.

The initial adjustment of the HFS controls, when the HFS is used as a converter, is the same as that outlined above except that the INTERNAL-EXTERNAL switch is set at External. The REGENERATION and AUDIO controls are inoperative with this setting. Adjust the dial setting of the associated receiver to the center of the I.F. pass-band of the HFS and the other controls for the desired output. The I.F. pass-band of the HFS will be located on the associated receiver at about 10.7 megacycles and will be indicated by a sharp increase in the receiver background noise. Adjust the OUTPUT control at the rear of the HFS for the proper gain to provide best reception with the associated receiver. A slight reading on the S-meter of a communication receiver will serve as a good indication of the proper setting of the OUTPUT control.

SECTION 4. SERVICE AND TEST DATA

4-1. General Maintenance Data

The HFS Receiver and associated Power Unit are designed and constructed to assure a long period of uninterrupted service. A few service hints are given below to aid in locating individual components which, due to age or weakness, may cause faulty operation of the Receiver.

Vacuum tube failure may be evidenced

by reduction in sensitivity, intermittent operation or an inoperative Receiver. Tubes may be checked in suitable tube testing equipment, or by replacement with tubes of proven quality. Care must be taken that tubes removed for checking are returned to their original sockets to avoid the possibility of the need of realignment.

Bypass or filter capacitors which be-

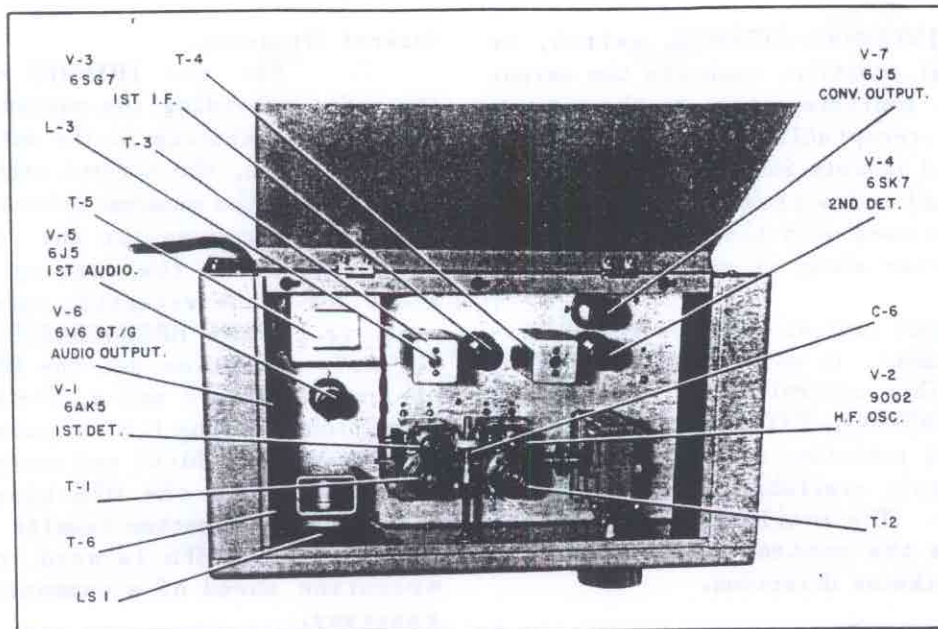

Figure No. 3. Top View of Receiver

come open may cause decreased sensitivity, poor stability or complete failure of the Receiver. The defective unit can be located by temporarily connecting a good capacitor in parallel with each suspected capacitor. Leaky or short-circuited capacitors can be detected by an ohmmeter check; a zero resistance reading on the ohmmeter will indicate a shorted capacitor.

Defective resistors, sometimes caused by capacitor failure in associated circuits, can be located by measuring the resistance of each resistor. The Schematic Diagram should be consulted to ascertain that any particular resistor under test is not connected in parallel with some other circuit element which might produce a false measurement. An overloaded resistor may be located by visual inspection if the surface of the resistor becomes scorched due to excessive heating.

4-2. Voltage Tabulation

The measurements of voltage shown on the following table are tabulated with the HFS installed using the 5886 Power Unit supplied from a power source of 115 volts, 50/60 cycles. The measuring instrument used is a high impedance vacuum tube voltmeter. The control settings observed are as follows:

1. A.C. switch on the 5886 at On.
2. B plus switch at On.
3. REGENERATION control at 10.

4. AUDIO control at zero.
5. INTERNAL-EXTERNAL switch at Internal except as noted on the voltage table.
6. Band B coils plugged into Receiver.
7. Main Tuning dial at 140 Mc.

TUBE TERMINAL	PIN	VOLTS \pm 15%
First Det. Grid	1	-1.2
First Det. Cathode	2-7	0
First Det. Screen	6	38
First Det. Plate	5	172
H.F. Osc. Grid	6	-4
H.F. Osc. Cathode	2-7	0
H.F. Osc. Plate	1-5	125
I.F. Amp. Grid	4	0
I.F. Amp. Cathode	3-5	1.5
I.F. Amp. Screen	6	120
I.F. Amp. Plate	8	172
Second Det. Grid	4	-3.5
Second Det. Cathode	5	0.5
Second Det. Plate	3-6-8	46
First Audio Grid	5	0
First Audio Cathode	8	3.8
First Audio Plate	3	90
Audio Output Grid	5	0
Audio Output Cathode	8	9.5
Audio Output Screen	4	171
Audio Output Plate	3	167
Converter Output Grid	5	0*
Converter Output Cathode	8	2.2*
Converter Output Plate	3	135*

* Internal-External switch at External.

5-1. I.F. Amplifier Alignment

The intermediate frequency of the HFS Receiver is 10.7 megacycles. The I.F. and detector input transformers have permeability-tuned iron-core inductors with screw adjustments for alignment purposes.

The alignment procedure is as follows:

1. Connect an output meter with a resistive load of 5,000 ohms to pins 3 and 4 (plate and screen) of the audio output tube.

2. Connect the "high" output lead of an accurately calibrated signal generator through a combination of a 0.001 microfarad capacitor shunted by a 50,000 ohm resistor, to the grid pin of the first detector coil socket. In order to do this it is necessary to remove the first detector coil from its socket and to terminate the generator lead in a suitable tip jack for insertion into the grid socket pin. Care should be taken when inserting the tip jack not to damage the socket pin by exerting undue force. The grid pin on the socket is the right-hand rear pin when viewed from the front of the Receiver.

Connect the ground lead of the generator to any convenient grounded point on the chassis. Set the signal generator at 10.7 megacycles, turn the modulation on and adjust the attenuator for an output of 3 microvolts or less.

3. Turn the HFS on by setting the B plus switch at B plus and set the REGENERATION control at about 4, the start of the superregenerative condition. Set the AUDIO control for the desired volume and the INTERNAL-EXTERNAL switch at Internal.

4. Adjust the tuned inductors L-6, L-3 and L-4 for maximum output, as indicated on the output meter, in the order named. The setting of the REGENERATION control must be correct to assure proper alignment. The correct setting of the control is that setting that produces a hiss in the background of the signal, the absence of this hiss indicates that the REGENERATION control and/or the signal generator output has been advanced too far and needs to be retarded. The multiplier on the output meter should be retarded as necessary to provide a readable indication.

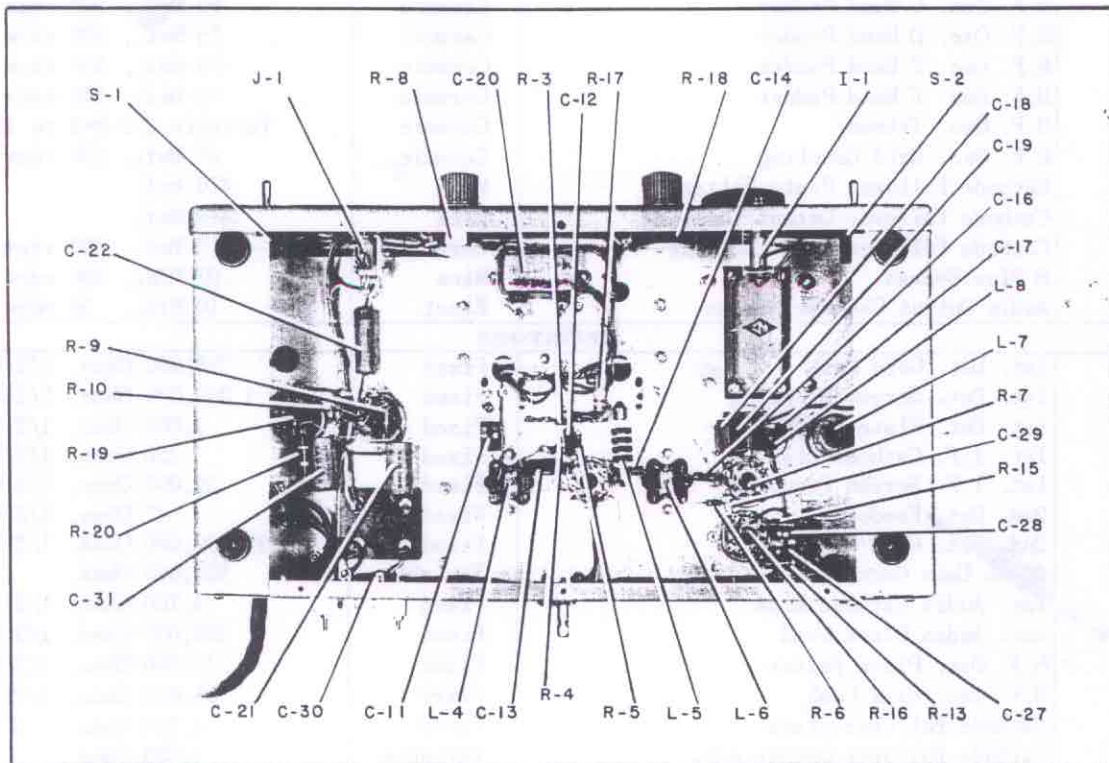

Figure No. 4. Bottom View of Receiver

SECTION 6.

PARTS LIST

Symbol	Function	Type	Rating
CAPACITORS			
C-1	10.7 Mc. Filter	Ceramic	100 Mmf., 500 vdcw
C-2	10.7 Mc. Filter	Ceramic	100 Mmf., 500 vdcw
C-3	Antenna Coupling	Ceramic	47 Mmf., 500 vdcw
C-4	Antenna Coupling	Ceramic,	47 Mmf., 500 vdcw
C-5	Main Tuning Capacitor	Variable	Variable 2 Section
C-5A	Det. Tuning	Air	Variable 3-21 Mmf.
C-5B	Osc. Tuning	Air	Variable 3-21 Mmf.
C-6	Antenna Trimmer	Air	Variable 2 to 5 Mmf.
C-7	1st. Det. Grid Coupling	Ceramic	47 Mmf., 500 vdcw
C-8	1st. Det. Screen Filter	Ceramic	47 Mmf., 500 vdcw
C-9	T-3 Primary Tuning	Ceramic	100 Mmf., 500 vdcw
C-10	T-3 Secondary Tuning	Ceramic	100 Mmf., 500 vdcw
C-11	1st. Det. Plate Filter	Mica	470 Mmf.
C-12	1st. Det. Plate Filter	Mica	470 Mmf.
C-13	1st. I.F. Cathode Bypass	Mica	0.0062 Mfd., 500 vdcw
C-14	T-4 Coupling	Ceramic	100 Mmf., 500 vdcw
C-15	T-4 Tuning	Ceramic	20 Mmf., 500 vdcw
C-16	2nd. Det. Grid Coupling	Ceramic	47 Mmf., 500 vdcw
C-17	2nd. Det. Cathode Tuning	Mica	470 Mmf.
C-18	2nd. Det. Quench Filter	Mica	0.01 Mfd., 300 vdcw
C-19	2nd. Det. Plate Bypass	Mica	0.0062 Mfd., 500 vdcw
C-20	2nd. Det. Plate Filter	Paper	0.5 Mfd., 250 vdcw
C-21	1st. Audio Cathode Bypass	Elect.	10 Mfd., 50 vdcw
C-22	Audio Coupling	Paper	0.1 Mfd., 400 vdcw
C-23	H.F. Osc. Coupling		Part of C-5A and C-5B
C-24	H.F. Osc. A Band Padder	Ceramic	125 Mmf., 500 vdcw
	H.F. Osc. B Band Padder	Ceramic	116 Mmf., 500 vdcw
	H.F. Osc. C Band Padder	Ceramic	95 Mmf., 500 vdcw
	H.F. Osc. D Band Padder	Ceramic	75 Mmf., 500 vdcw
	H.F. Osc. E Band Padder	Ceramic	75 Mmf., 500 vdcw
	H.F. Osc. F Band Padder	Ceramic	76 Mmf., 500 vdcw
C-25	H.F. Osc. Trimmer	Ceramic	Variable 2.5 Mmf to 13. Mmf.
C-26	H.F. Osc. Grid Coupling	Ceramic	47 Mmf., 500 vdcw
C-27	Cathode Follower Plate Filter	Mica	470 Mmf.
C-28	Cathode Follower Output Coupling	Mica	470 Mmf.
C-29	Cathode Follower Grid Coupling	Ceramic	3 Mmf., 500 vdcw
C-30	B Plus Bypass	Mica	.01 Mfd., 300 vdcw
C-31	Audio Output Cathode Bypass	Elect.	10 Mfd., 50 vdcw
RESISTORS			
R-1	1st. Det. Grid Leak	Fixed	270,000 Ohms, 1/2 W.
R-2	1st. Det. Screen Dropping	Fixed	1,000,000 Ohms, 1/2 W.
R-3	1st. Det. Plate Filter	Fixed	1,000 Ohms, 1/2 W.
R-4	1st. I.F. Cathode Bias	Fixed	220 Ohms, 1/2 W.
R-5	1st. I.F. Screen Dropping	Fixed	22,000 Ohms, 1/2 W.
R-6	2nd. Det. Feedback	Fixed	47 Ohms, 1/2 W.
R-7	2nd. Det. Grid Leak	Fixed	10,000,000 Ohms, 1/2 W.
R-8	Audio Gain Control	Variable	500,000 Ohms,
R-9	1st. Audio Cathode Bias	Fixed	4,700 Ohms, 1/2 W.
R-10	1st. Audio Plate Load	Fixed	100,000 Ohms, 1/2 W.
R-11	H.F. Osc. Plate Filter	Fixed	10,000 Ohms, 1/2 W.
R-12	H.F. Osc. Grid Leak	Fixed	47,000 Ohms, 1/2 W.
R-13	Cathode Follower Plate	Fixed	4,700 Ohms, 1 W.
R-14	Cathode Follower Output Adj.	Variable	1,000 Ohms
R-15	Cathode Follower Load Dropping	Fixed	330 Ohms, 1/2 W.

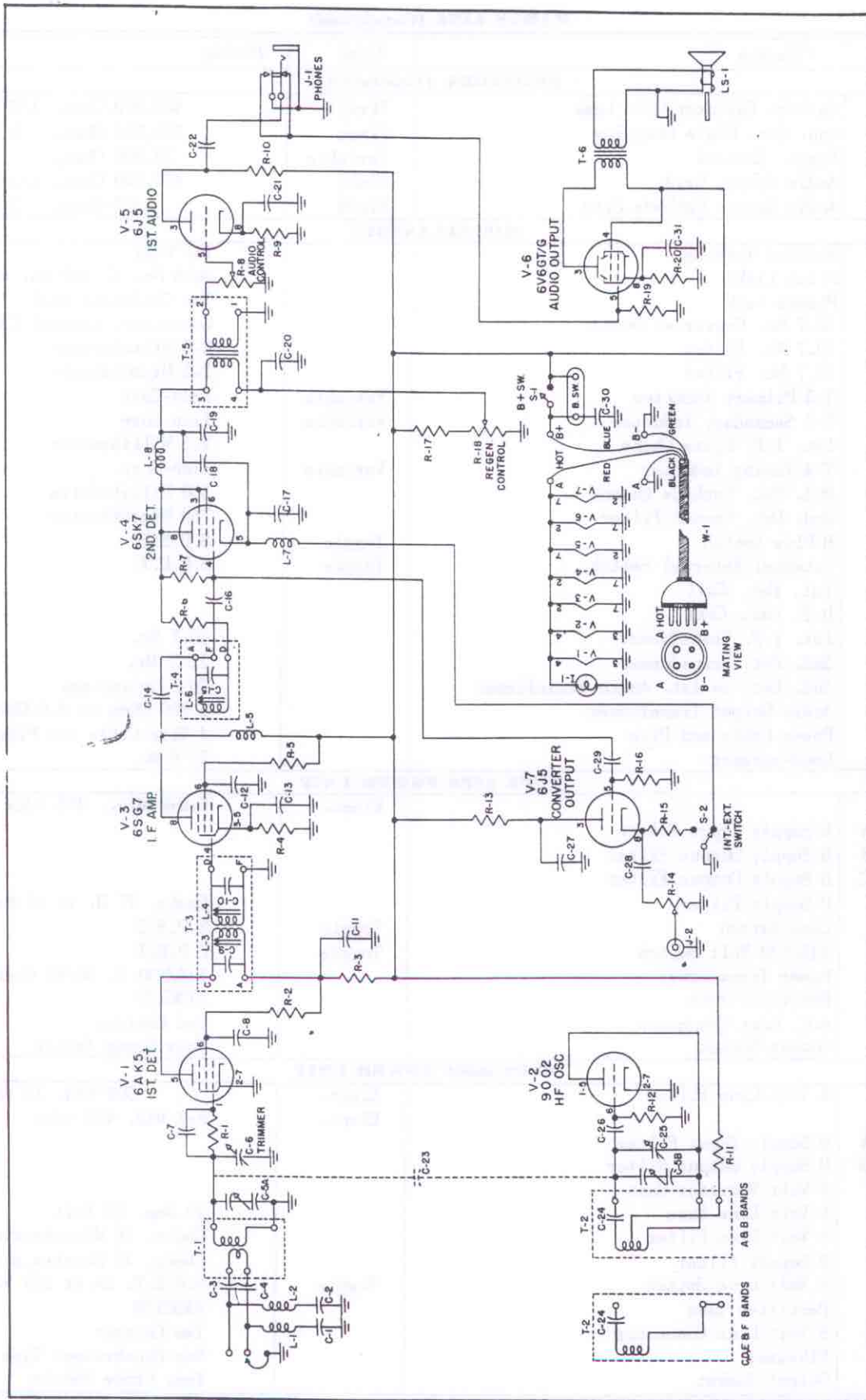

Figure No. 5. Schematic Diagram - HFS Receiver

PARTS LIST (Continued)

Symbol	Function	Type	Rating
RESISTORS (Continued)			
R-16	Cathode Follower Grid Leak	Fixed	470,000 Ohms, 1/2 W.
R-17	2nd. Det. Plate Dropping	Fixed	150,000 Ohms, 1 W.
R-18	Regen. Control	Variable	50,000 Ohms,
R-19	Audio Output Grid	Fixed	470,000 Ohms, 1/2 W.
R-20	Audio Output Cathode Bias	Fixed	470 Ohms, 2 W.
MISCELLANEOUS			
E-1	Antenna Terminal		Two Post
I-1	Pilot Light		Bulb No. 47 150 Ma. 6-8 V.
J-1	Phones Jack		Two Conductor Jack
J-2	10.7 Mc. Converter Output		Connector, Coaxial Cable
L-1	10.7 Mc. Filter		2.5 Microhenries
L-2	10.7 Mc. Filter		2.5 Microhenries
L-3	T-3 Primary Inductor	Variable	Iron-Core
L-4	T-3 Secondary Inductor	Variable	Iron-Core
L-5	1st. I.F. Plate Choke		2.5 Millihenries
L-6	T-4 Tuning Inductor	Variable	Iron-Core
L-7	2nd. Det. Cathode Quench		350 Millihenries
L-8	2nd. Det. Quench Filter		750 Microhenries
S-1	B Plus Switch	Toggle	S.P.S.T.
S-2	Internal-External Switch	Toggle	S.P.D.T.
T-1	1st. Det. Coil		
T-2	H.F. Osc. Coil		
T-3	1st. I.F. Transformer		10.7 Mc.
T-4	2nd. Det. Transformer		10.7 Mc.
T-5	2nd. Det. to 1st. Audio Transformer		3/1 Interstage
T-6	Audio Output Transformer		5,000 Ohms to 4.0 Ohms
W-1	Power Cable and Plug		4 Wire Cable and Plug
LS-1	Loud-speaker		5" P.M.
TYPE 5886 POWER UNIT			
C-101		Elect.	8+8+8 Mfd., 475 vdcw
C-101A	B Supply Input Filter		
C-101B	B Supply Output Filter		
C-101C	B Supply Output Filter		
L-101	B Supply Filter		Choke, 17 H. at 80 Ma.
S-101	Line Switch	Toggle	S.P.S.T.
S-102	115/230 Volt Switch	Toggle	D.P.D.T.
T-101	Power Transformer		115/230 V. 50/60 Cycles
V-101	Rectifier Tube		5Y3GI/G
W-101	A.C. Line Connector		Two Contact
X-101	Output Socket		Four Prong Female
TYPE 686S POWER UNIT			
C-201	6 Volt Line Filter	Elect.	500 Mfd. 15 vdcw
C-202		Elect.	8+8 Mfd. 475 vdcw
C-202A	B Supply Input Filter		
C-202B	B Supply Output Filter		
E-201	6 Volt Vibrator Unit		
F-201	6 Volt Line Fuse		10 Amp. 25 Volt
L-201	6 Volt Line Filter		Choke, 16 Microhenries
L-202	B Supply Filter		Choke, 17 Henries at 80 Ma.
S-201	6 Volt Line Switch	Toggle	S.P.S.T. 3A at 250 V.
V-201	Rectifier Tube		6X5GI/G
W-201	6 Volt Line Connector		Two Contact
Y-201	Vibrator		Non-Synchronous Type
X-201	Output Socket		Four Prong Female

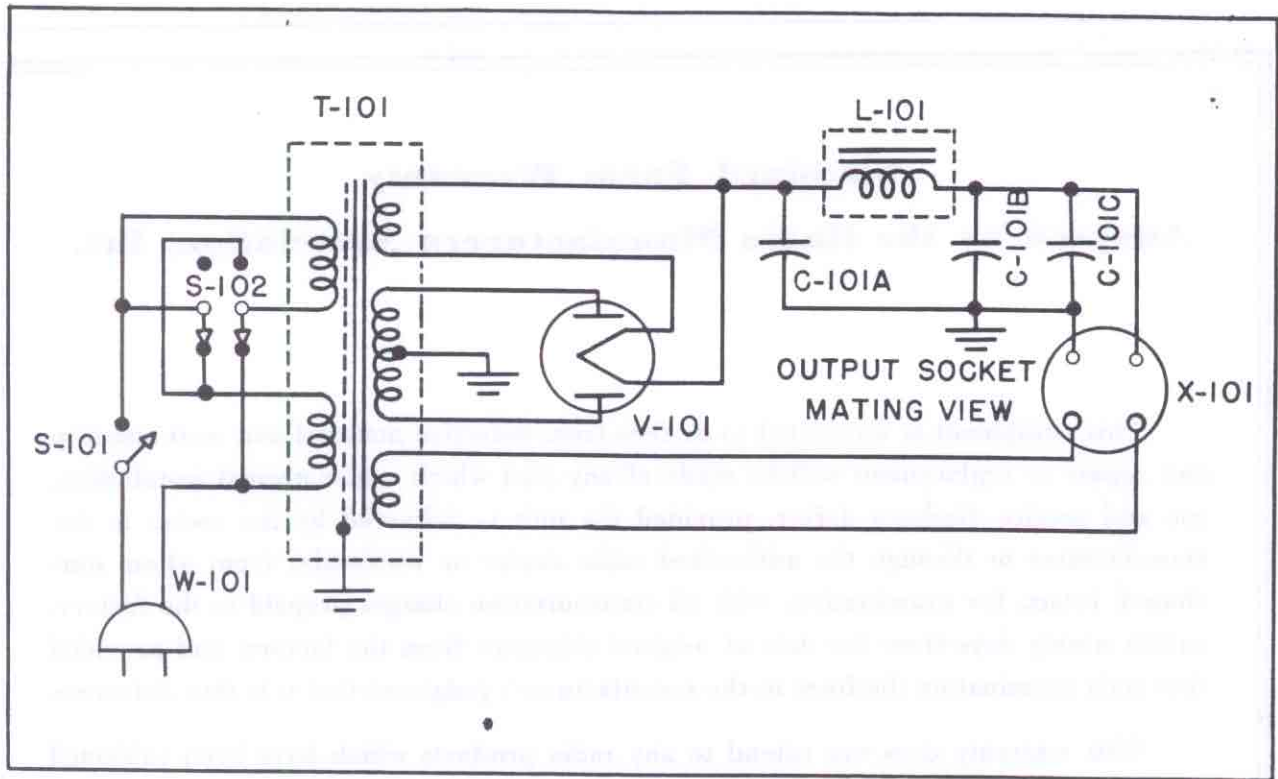

Figure No. 6. Schematic Diagram - 5886 Power Unit

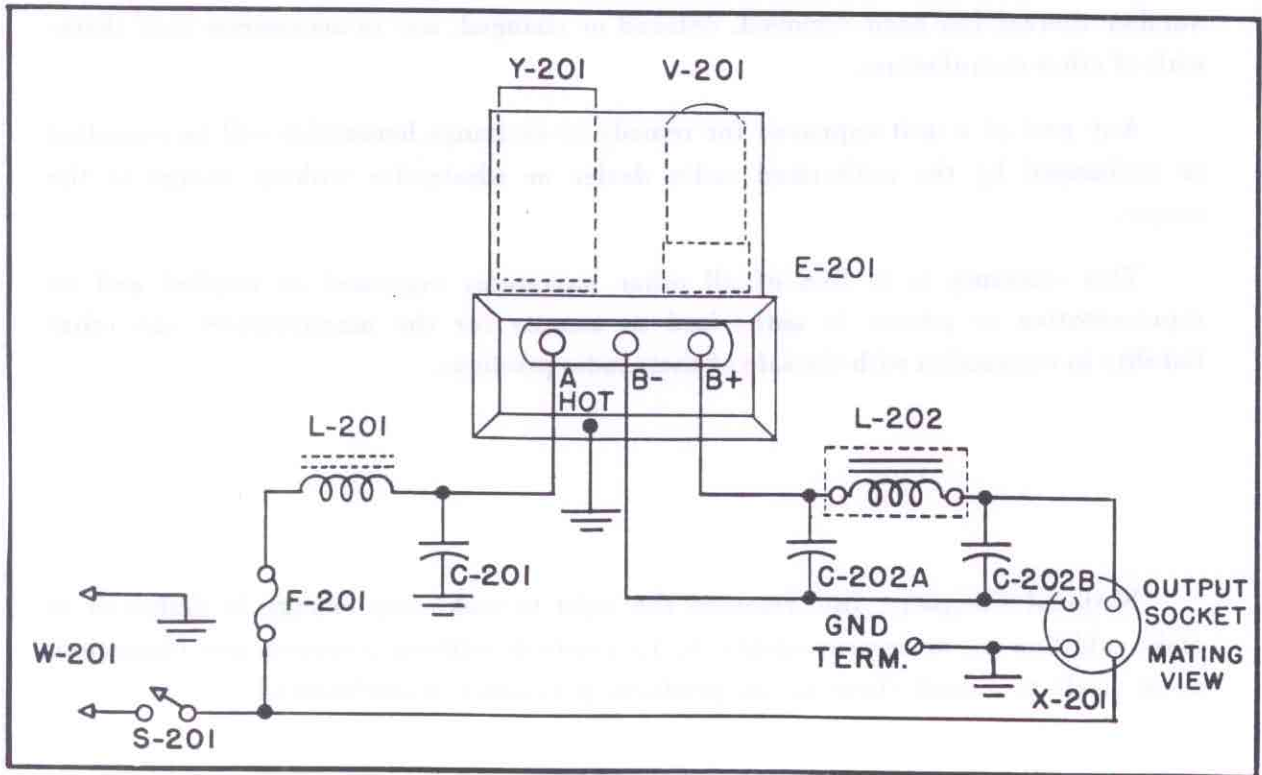

Figure No. 7. Schematic Diagram - 686S Power Unit

Standard Form Warranty

Adopted by the Radio Manufacturers Association, Inc.

This equipment is warranted to be free from defective material and workmanship and repair or replacement will be made of any part which under normal installation, use and service discloses defect, provided the unit is delivered by the owner to the manufacturer or through the authorized radio dealer or wholesaler from whom purchased, intact, for examination, with all transportation charges prepaid to the factory, within ninety days from the date of original shipment from the factory, and provided that such examination discloses in the manufacturer's judgment that it is thus defective.

This warranty does not extend to any radio products which have been subjected to misuse, neglect, accident, incorrect wiring, improper installation, or to use in violation of instructions furnished by the manufacturer, nor extend to units which have been repaired or altered outside of the factory, nor to cases where the serial number thereof has been removed, defaced or changed, nor to accessories used therewith of other manufacture.

Any part of a unit approved for remedy or exchange hereunder will be remedied or exchanged by the authorized radio dealer or wholesaler without charge to the owner.

This warranty is in lieu of all other warranties expressed or implied and no representative or person is authorized to assume for the manufacturer any other liability in connection with the sale of their radio products.

National Company, Inc. reserves the right to make any change in design or to make addition to, or improvements in, its products without imposing any obligations upon itself to install them in its products previously manufactured.



NATIONAL COMPANY, INC.
MALDEN, MASS.
U. S. A.