

**LOWE SRX-30D**

## FRONT PANEL CONTROLS AND INDICATORS

Fig.1

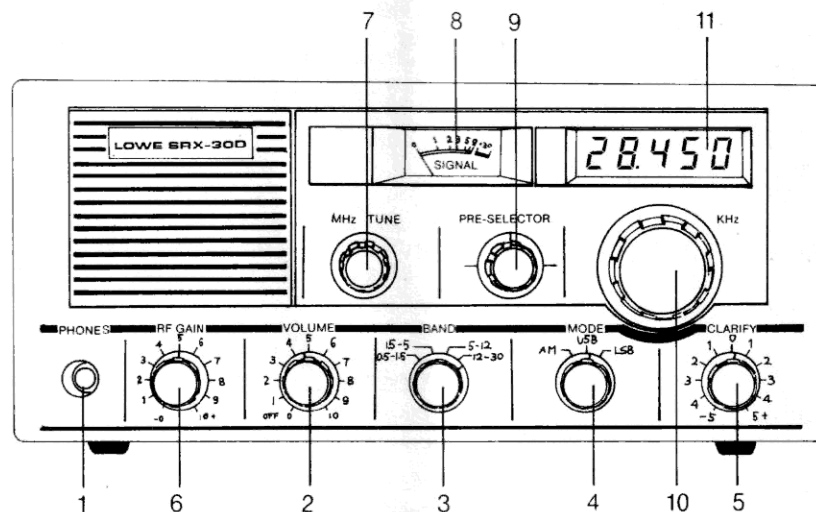

1. Phone Jack: For headphone reception or external speaker (8Ω). Insertion of phones or speaker jack cuts the internal speaker.
2. Off - Volume: Turns radio on and off and adjusts audio output level.
3. Band: Selects the proper range of received frequency.
4. Mode: Selects mode of reception. AM(amplitude modulation), USB(upper single side band) and LSB (lower single side band). CW (continuous wave) may be received on either USB or LSB positions. The mode selector selects the proper detector (product detector for SSB and diode detector for AM and IF selectivity filter).
5. Clarify: Provides ultra fine frequency adjustment. This control is used primarily on SSB and CW signals for setting the pitch or sound accurately after the station has been roughly tuned in. It should be in the centre position before tuning is commenced.
6. RF Gain Control: RF gain control provides about 30 dB attenuation to received signal when in fully counter clockwise position.
7. MHz Control: Tunes the MHz range of the receiving frequency. The frequency display (11) brighten most automatically when the MHz control is properly tuned.
8. Signal Meter: Indicates the relative RF input signal level.
9. Pre-Selector: Adjusts receiver RF tuned circuits for proper reception of signal. This control is tuned for maximum signal or noise at the selected frequency.

10. KHz Control: Tunes the KHz range of the receiving frequency, following the MHz tuning. This control covers the continuous shift of the frequency 000 - 999KHz. Three DOTS will appear when your tuning operation goes over the above range to indicate 'range over'.

9.9.6.                      0.0.3.

11. Frequency Display: Shows the frequency that you are receiving by 2 digits for MHz, and 3 digits for KHz, total 5 digits.

Note: When receiving below 1 MHz, the display indicates only the KHz. frequency.

28.450                      6.283                      .934

#### REAR PANEL CONNECTIONS

Fig.2

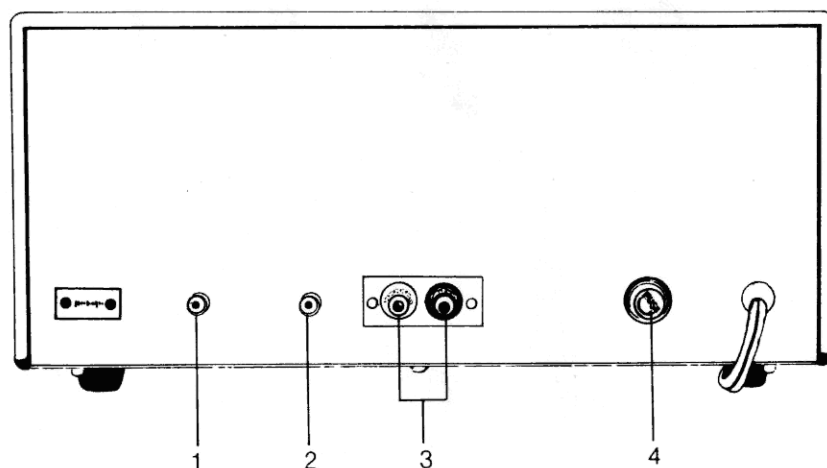

1. Record: Audio output is provided at this jack for tape recorder or other usage. This output is approximately 60mV RMS at 5000Ω.
2. Mute Jack: A shorted phone connector is normally installed in Mute jack. When the shorted connector is removed, the unit will be muted. This function is used when operating the receiver with a communications type transmitter. (amateur, CB, ect)
3. Antenna Terminal: The RED terminal is for the antenna connection, 50 - 75Ω unbalanced input. The BLACK terminal is for the grounding connection.
4. Fuse Holder: 1 A Fuse is installed, care should be taken to be used a specified one.

## OPERATING PROCEDURE

- Turn on: Turn the unit on by turning the VOLUME control (2 in fig.1) clockwise. This control also adjusts the volume and is used to adjust for desired sound level.
- Mode Selection: The reception mode AM, CW or SSB is selected by the MODE control (4). Select AM position for standard broadcast stations and either USB or LSB for single side band transmissions. CW signals are received on either USB or LSB positions.
- Frequency Tuning: Frequency selection is obtained by operating controls 3, 5, 7 & 10 in Fig. 1.
- Turn CLARIFY control (5) to 0.
  - Select BAND switch (3) portion to encompass desired frequency.
  - Turn MHz control dial carefully till the frequency display brighten most, which is the indication of the best tuning point of the MHz reception.
  - Turn KHz control dial carefully till the frequency display come to your desired frequency.

Following procedure will properly select the desired frequency of reception and be adjusting the PRE-SELECTOR (9) for maximum signal or noise will tune the receiver for proper reception. Fine adjustment of the MHz control (7) will sometimes increase the sensitivity. Weh the desired station is heard fine adjustment of KHz control (10) may be used to tune in the station for proper reception. The CLARIFY control (5) may be used for fine tuning a station for good reception. (This control is usually used for proper tuning of SSB or CW signals. It can also be used to fine tune signals in the AM band.)

### EXAMPLE

1.350

- Desired signal is AM at a frequency of 1.350MHz.
- Turn receiver on. Adjust VOLUME control (2) clockwise.
  - Set MODE control (4) to AM.
  - Set CLARIFY control (5) to 0.
  - Set BAND control (3) to 0.5 - 1.5 position.
  - Turn MHz control dial to brighten the first digit '1' (1 MHz.)
  - Turn KHz control till the last three digits come to your desired frequency '350' (350 KHz.)
  - Tune PRE-SELECTOR control (9) for maximum signal or noise.
  - Fine adjust MHz control (7) to obtain maximum signal or noise.
  - Fine tune KHz control (10) for proper sound of signal.
  - Desired output level is adjusted by turning the VOLUME control (2) clockwise for increased volume.

## SPECIFICATIONS

Frequency Coverage: 0.5 to 30 MHz.

Reception Modes: CW, USB, LSB & AM

Sensitivity: At least 10dB S+N/N under following conditions;

MODE	INPUT LEVEL
SSB	0.3 $\mu$ V
AM	1.0 $\mu$ V

(AM: 1000Hz @30% modulation)

Output: Capable of 200mW output on SSB at 2 MHz. with input signal of 0.5 $\mu$ V and 2 Watts output with 5 $\mu$ V input.

Audio Distortion: Less than 5% 2 Watts

Selectivity:

Mode	-6dB
SSB	4 KHz
AM	8 KHz

Image Rejection: Greater than 50dB

IF Rejection: Greater than 50dB

Antenna: External connection to terminal strip. 50 $\Omega$  input impedance (unbalanced).

Audio Output Provisions: Internal 8 $\Omega$  speaker. A phone jack on the front panel which disables the internal speaker when plugged in.

Power Supply: AC 110V, 117V, 220V/50 - 60 Hz.

Clarifier: Over  $\pm$ 0.5 KHz.

Size: 325mm(12.8")W x 230mm(9")D x 140mm(5.5")H

Weight: 5Kgs. (11 lbs)

# DISPLAY SCHEMATIC DIAGRAM

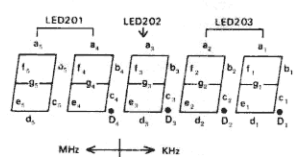
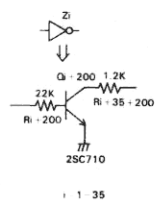
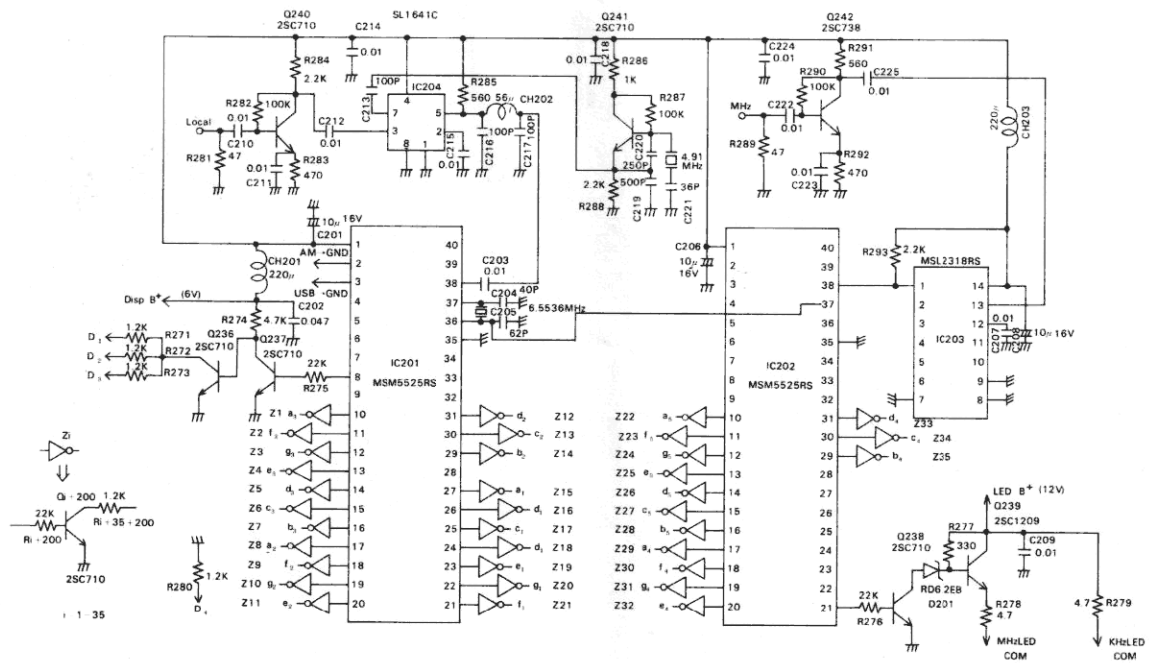



# FRONT-END SCHEMATIC DIAGRAM

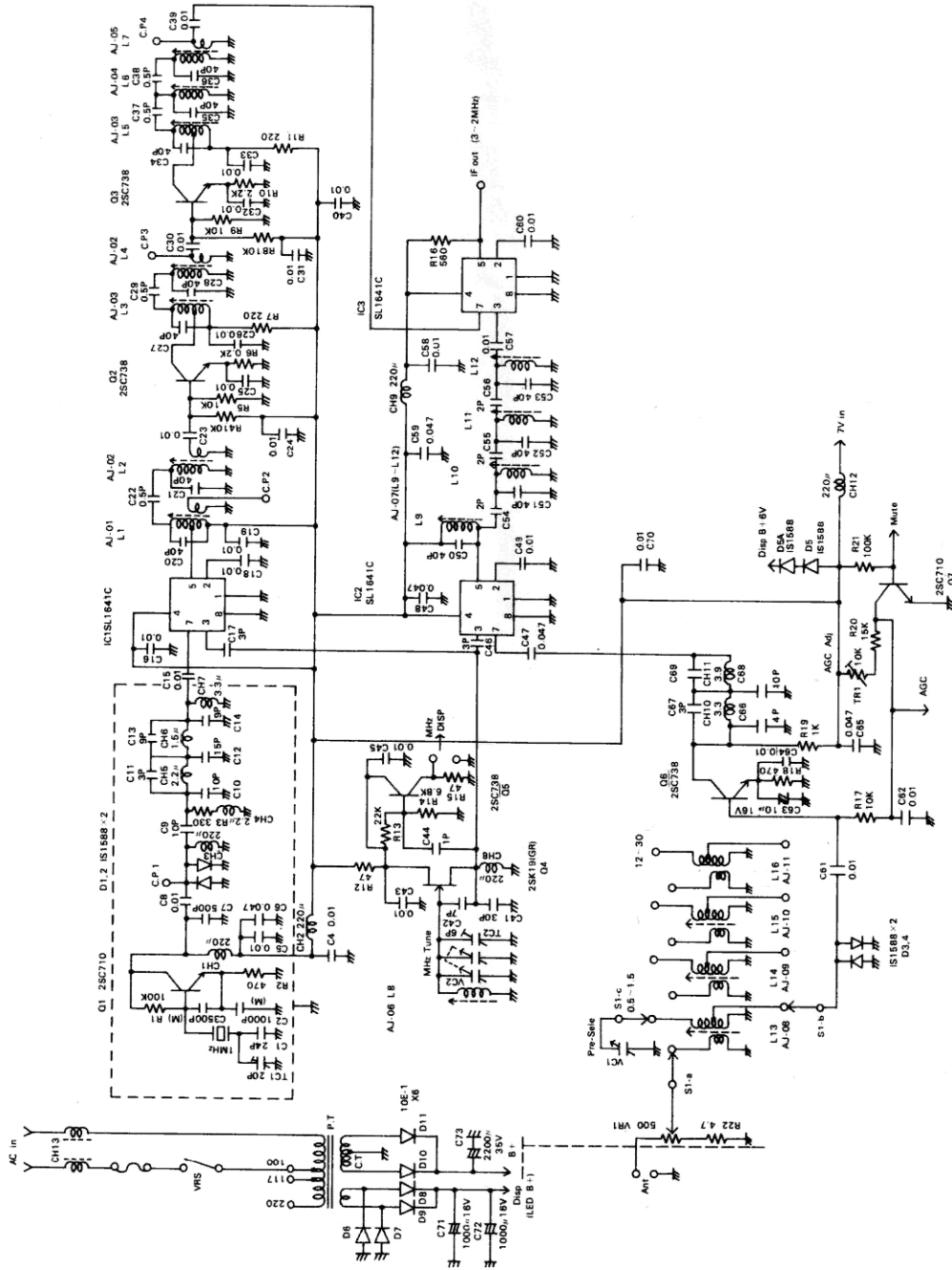



THAT'S ALL  
THE CIRCUIT  
IN THE BOOK!