

KENWOOD

SERVICE MANUAL

TR-7400A



2m FM TRANSCEIVER

INTRODUCTION/CONTENTS

Your KENWOOD Model TR-7400A is a high-quality 2-meter transceiver for use in amateur radio mobile stations as well as base stations. It contains a PLL frequency synthesizer developed and engineered through KENWOOD's elaborate VHF technology to provide high performance and outstanding technical characteristics.

The TR-7400A is capable of transmitting or receiving F3 FM signals on up to 800 Channels at intervals of 5 kHz, having 25W RF output power.

CONTENTS

SPECIFICATIONS	3
FINAL TRANSISTOR SPECIFICATIONS	4
BLOCK DIAGRAM	5
CIRCUIT DESCRIPTION	6
PARTS ALIGNMENT	11
PC BOARD	
PA UNIT (X45-1090-10)	13
PD UNIT (X50-1380-10)	14
VCO UNIT (X50-1370-10)	15
INDICATOR UNIT (X54-1210-10)	16
RX UNIT (X55-1150-10)	17
TX UNIT (X56-1230-10)	18
PARTS LIST	19
PACKING	25
DISASSEMBLY	26
TROUBLESHOOTING	29
LEVEL DIAGRAM	32
ADJUSTMENTS	33
SCHEMATIC DIAGRAM	40

SPECIFICATIONS

GENERAL

Semiconductors	Transistors	58
	FETs	8
	ICs	19
	Diodes	63
Frequency Range	144.00 to 147.995 MHz	
Frequency Synthesizer	Digital (TTL Logic) control of phase locked VCO	
Synthesizer Stability	Less than ± 750 Hz at 25°C	
Mode	FM	
Number of Channel	800	
Operating Temperature	-20 to +50°C	
Power Voltage	11.5 VDC to 16.0 VDC (13.8 VDC as reference)	
Grounding	Negative grounding	
Antenna Impedance	50 Ω	
DC Current	Less than 1A in receive with no input signal Less than 8A in transmit (HI) Less than 4.5A in transmit (LOW) (at 13.8 VDC)	
Dimension	182 mm (7-3/16") wide 74 mm (2-7/8") high 270 mm (10-5/8") deep	
Weight	Approx. 2.8 kg (6.2 lbs.)	

TRANSMIT SECTION

RF Output Power	High 25 watts (min.) Low approx. 5 watts (adjustable up to 15 watts)
Modulation	Variable reactance direct shift
Max. Frequency Deviation	± 5 kHz
Spurious Radiation	Less than -60 dB
Touch Tone Input Impedance	600 Ω
Microphone	Dynamic microphone with PTT switch, 500 Ω

RECEIVE SECTION

Circuitry	Double superheterodyne
Intermediate Frequency	1st IF 10.7 MHz 2nd IF 455 kHz
Sensitivity	Less than 0.4 μ V for 20 dB quieting (Less than 1 μ V for 30 dB S/N) Less than 0.25 μ V
Squelch Sensitivity	Less than 0.25 μ V
Pass Band Width	More than 12 kHz at 6 dB down
Selectivity (2 Signal)	More than 72 dB at 30 kHz of adjacent channel
Image Rejection	More than 70 dB
Spurious Interference	More than 60 dB
Intermodulation	More than 66 dB
Audio Output	More than 1.5 watts across 8 Ω load (10% distortion)

OPTION

i) Tone Squelch	
Tone Deviation	± 0.5 kHz (adjusted)
Encoder Response	Less than 0.5 sec.
Frequency Stability	Less than $\pm 1\%$
Tone Squelch Open Sensitivity	Less than SINAD 10 dB
Tone Distortion	Less than 5%
ii) Tone Burst	
Burst Time	Approx. 0.5 sec. (adjusted)

NOTE: The circuit and ratings may change without notice due to development in technology.

Final Transistor (2N6083) Specifications

Maximum Ratings $T_A = 25^\circ\text{C}$ (Unless otherwise specified)

Item	V_{CB0}	V_{CE0}	V_{EBO}	I_C	P_D	Stud torque	T_{stg}
Unit	V	V	V	A	$T_A = 75^\circ\text{C}$ W	in lb	$^\circ\text{C}$
Ratings	36	18	4	4	65	6.5	-65 to 200

Characteristics Standard $T_A = 25^\circ\text{C}$ (Unless otherwise specified.)

Symbol	Condition	Standard value		Unit	LTPD level	
		Minimum	Maximum			
I_{CBO}	$V_{CB} = 15\text{ V}$	/	1.0	mA	5	1
BV_{CES}	$I_C = 15\text{ mA}$	36	/	V	5	1
BV_{CEO}	$I_C = 100\text{ mA}$	18	/	V	5	1
BV_{EBO}	$I_E = 5\text{ mA}$	4	/	V	5	1
h_{FE}	$V_{CE} = 5\text{ V}, I_C = 1\text{ A}$	5	/		5	1
C_{ob}	$V_{CB} = 15\text{ V}, f = 0.1\text{ MHz}$	/	130	pF	10	1
G_{PE}	$V_{CC} = 12.5\text{ V}, P_{OUT} = 30\text{ W}$ $f = 175\text{ MHz}$	5.7	/	dB	10	1
η	$V_{CC} = 12.5\text{ V}, P_{OUT} = 30\text{ W}$ $f = 175\text{ MHz}$	65	/	%	10	1
I_{CES}	$V_{CE} = 15\text{ V}, T_C = 55^\circ\text{C}$	/	10	mA	5	1

2N6083

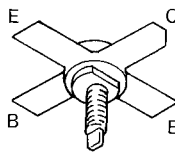

BLOCK DIAGRAM

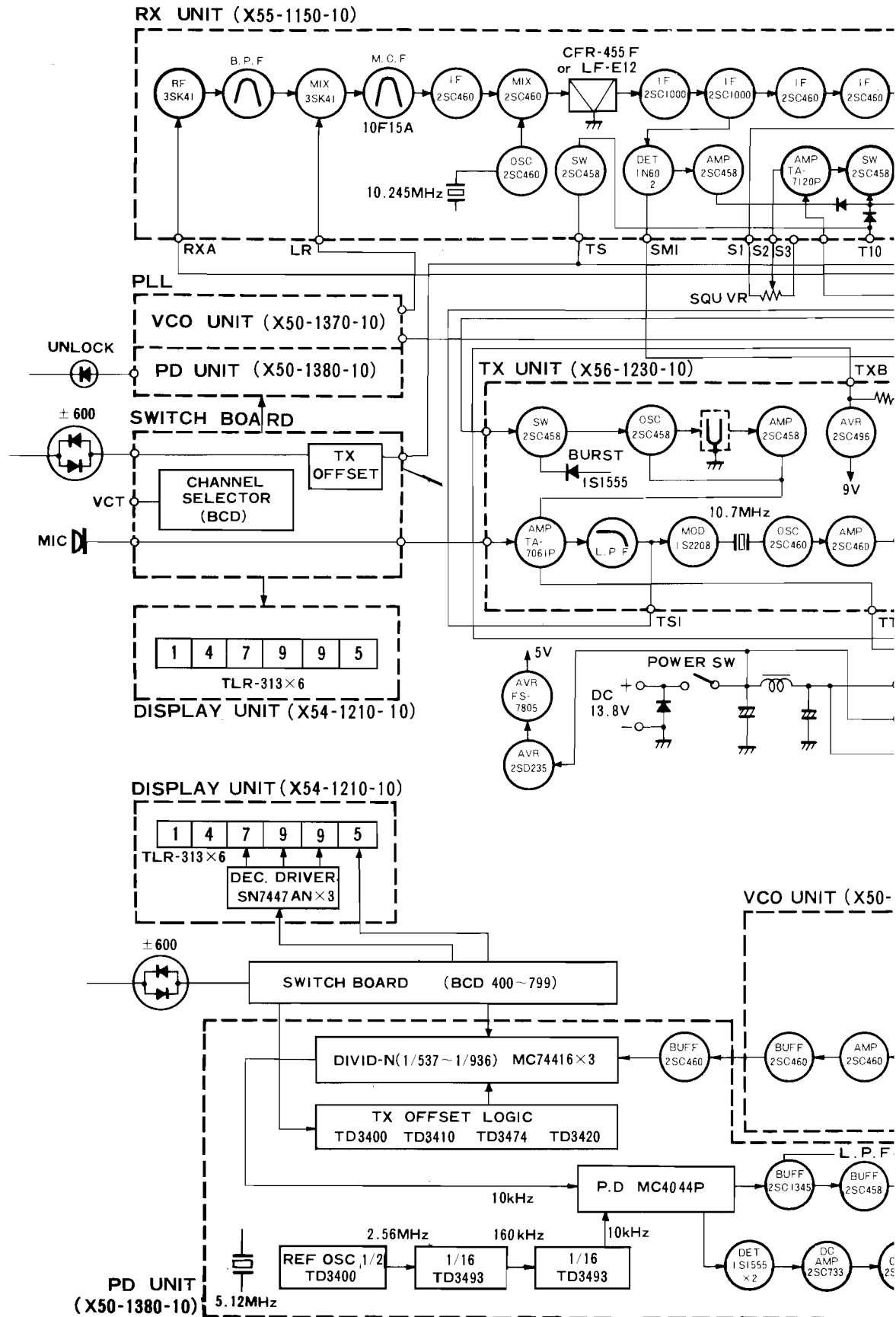

DIAGRAM

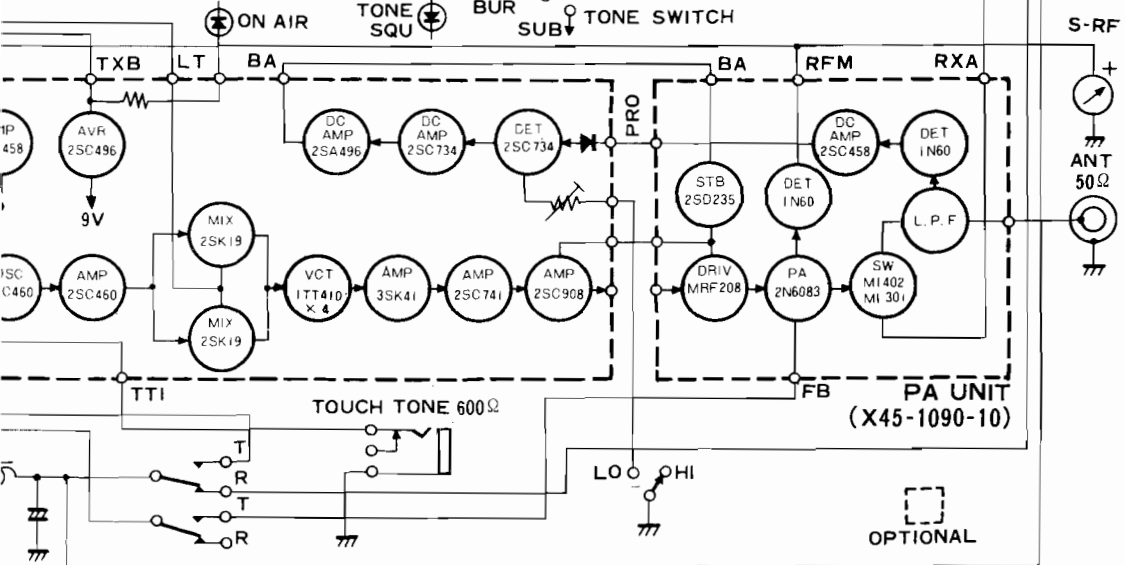
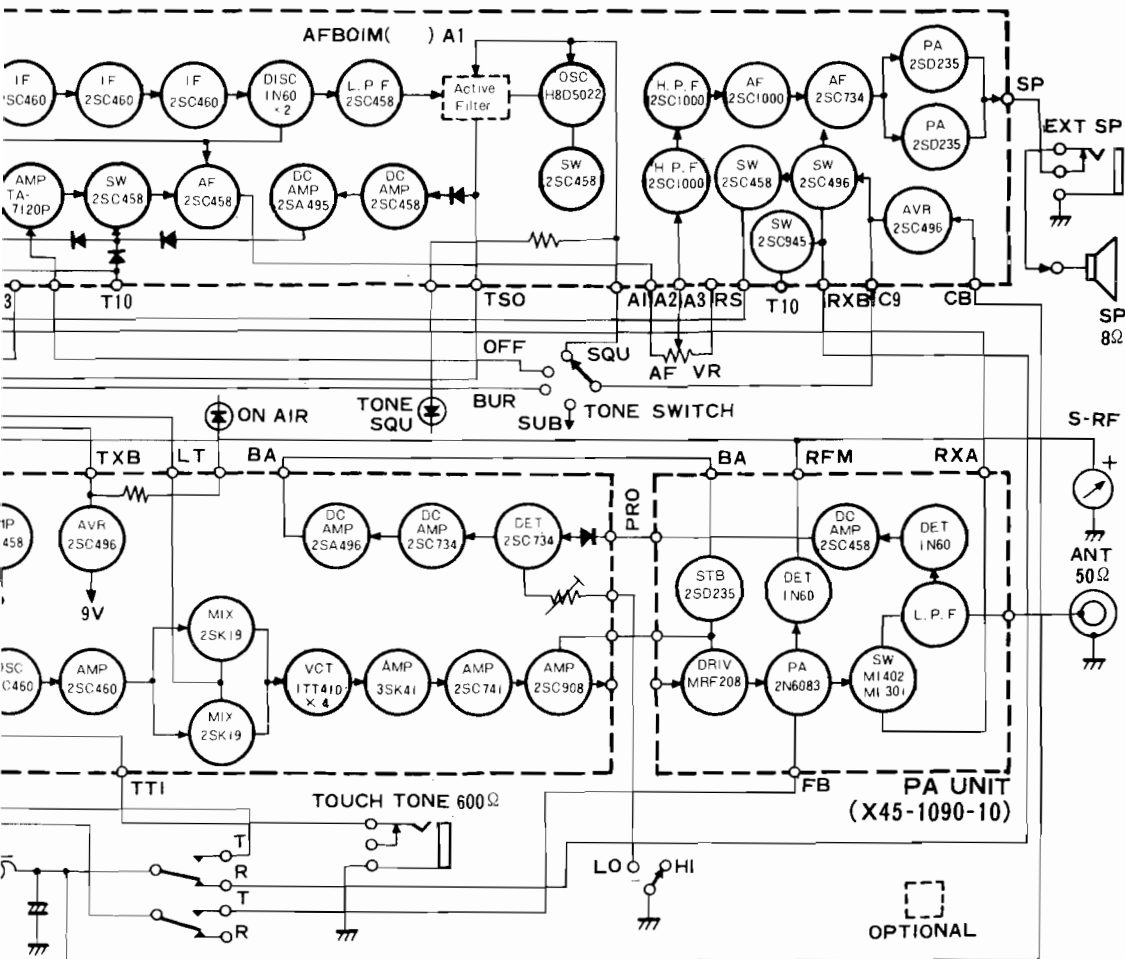

UNIT (X50-1370-10)

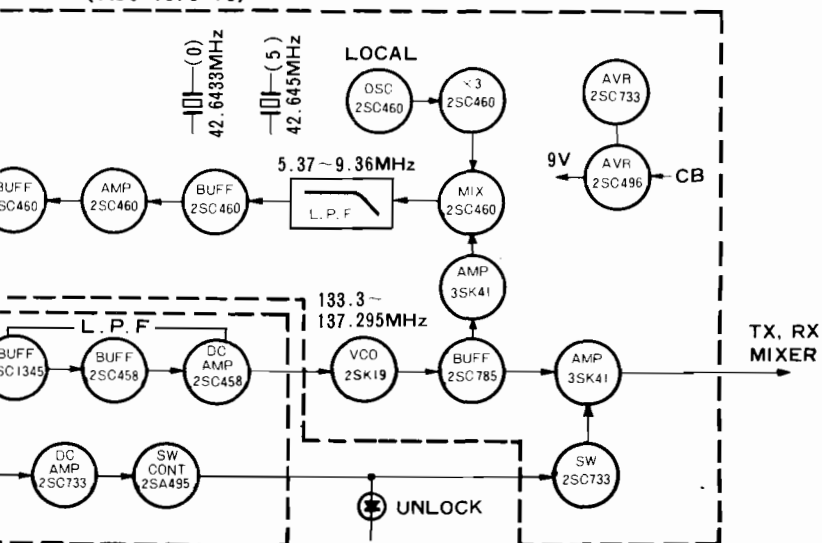

The block diagram of the TR-7400A is shown in page 5.

The TR-7400A incorporates newly developed circuit techniques such as a PLL frequency synthesizer as the local oscillator.

PLL CIRCUIT

The block diagram is given in Fig. 1.

The circuit is outlined below. The outputs of the VCO and LOCAL OSC are mixed together and converted to 5.37 ~ 9.36 MHz signal and divided to 1/537 ~ 1/936 with the programmable counter to obtain a 10 kHz output. The phases between the 10 kHz output and another 10 kHz signal obtained by demultiplying 5.12 MHz REF OSC output to 1/512, are compared. And the phase difference, if any, is fed back to the VCO to lock it. The stability of this function is determined by the LOCAL OSC and REF OSC, and the stability of the VCO is virtually equal to that of a crystal oscillator.

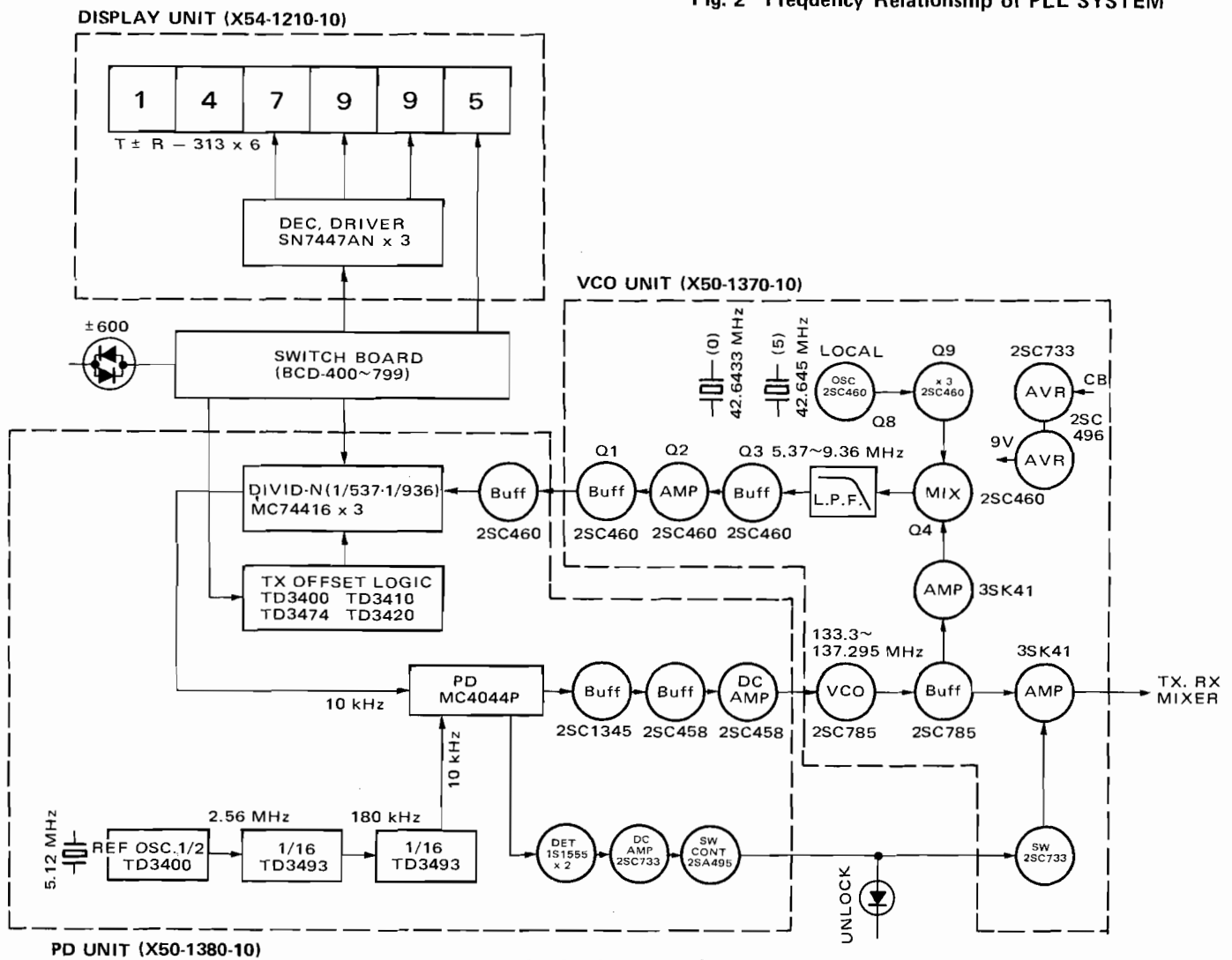

Fig. 1 PLL Circuit Block Diagram

Fig. 2 shows the frequency relationship of the system. Δf_r and Δf_l are the frequency deviations of the REF OSC and LOCAL OSC respectively. You will see how the VCO frequency changes with the deviations and N preset in the programmable counter.

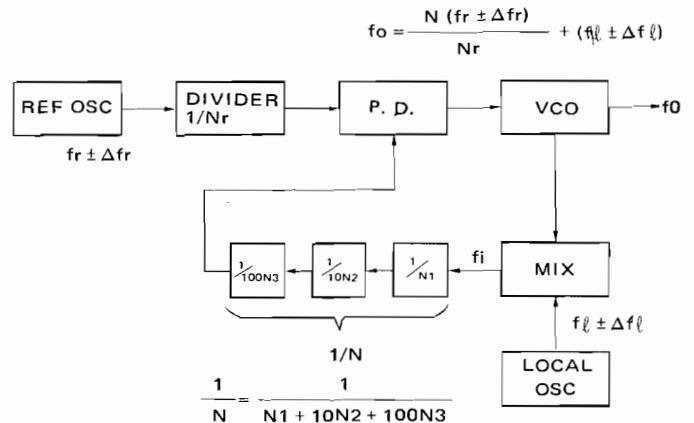

Fig. 2 Frequency Relationship of PLL SYSTEM

VCO UNIT (X50-1370-10)

The VCO is a Colpitts type oscillating circuit (Q7) and its frequency varies with the control voltage applied to varicap diode D1. This circuit is strictly stabilized against changes in temperature and power source voltage to improve the C/N of its output and prevent unlocking. The VCO's output is passed through buffer Q6, amplified by Q12 and applied to MIX through D6 and D7 for both reception and transmission.

In the LOCAL OSC, two quartz crystals for 0 and 5 kHz are switched with a switching diode. Q8 performs overtone oscillation and its output is tripled in Q9 to 127.930 and 127.935 MHz which are applied to MIX stage. The MIX circuit mixes the output and the VCO's output amplified by Q5, and its output is passed through a π -type LPF to deliver IF output of 5.37 ~ 9.36 MHz.

The output is amplified by the wide-band amplifier of Q1 to Q3 and applied to the programmable counter. Q13, which turns on and off VCO amp Q12, is a protective circuit in order to prevent emission of spurious radiation occurring when the PLL circuit fails to lock and the VCO runs away. This circuit is automatically reset when the PLL begins to work properly because it is not involved in the phase lock loop. D8 provides a certain time delay when Q13 is turned off, so Q13 does not operate during the transient state before the VCO is locked, though the indicator works. This contributes to reduce noise.

PD UNIT (X50-1380-10)

Q6 serves as the interface and buffer amp for IC8. The waveform of its IF output is shaped in IC8 and its output frequency is divided to 10 kHz by the programmable counter consisting of IC5 to 12 and the resulting signal is applied to MC4044P of IC4. While IC1 generates 5.12 MHz signal which is divided to 1/2 by the flip-flop circuit involved in IC1. The resulting frequency is further divided to 1/16 in IC2, IC3 and 10-kHz output signal is applied to MC4044P of IC4.

The MC4044P consists of two PDs (phase detectors), charge pump and amplifier. Fig. 3 shows the block diagram. Passing through the charge pump and active filter, the output of No. 1 PD becomes the control voltage to be applied to the varicap of the VCO. The active filter consists of Q1 to 3 to keep the VCO away from phase comparator noise. No. 1 PD, a digital phase comparator, contains a sequential logic circuit which operates at the edge of decay of signal coming to enter R and V terminal. Its state becomes as shown in Fig. 2 after a certain time. When R is not equal to V (unlocked state), D1 or D2 is turned on and Q5 turns on Q4 to switch off Q13, VCO amp driver, so that spurious emission which might occur if the PLL fails to lock is prevented.

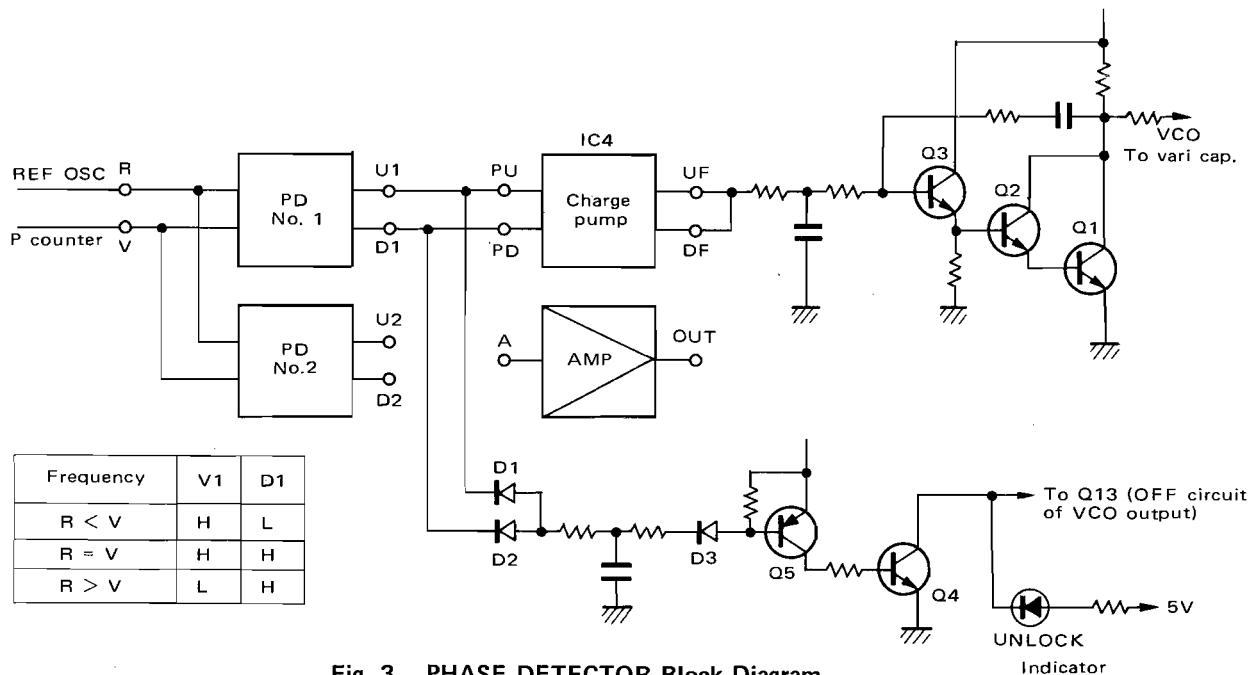

Fig. 3 PHASE DETECTOR Block Diagram

CIRCUIT DESCRIPTION

PROGRAMMABLE COUNTER AND TX-OFFSET CIRCUITS

These circuits, consisting of IC5 to IC12, are basically a MODULO-N PROGRAMMABLE counter of IC5 to IC7 added with an EXTENDER consisting of a D-flip-flop of IC10 and a logic circuit of IC8, 9, 11 and 12. It belongs to the high-speed scaling method. Fig. 4 shows the operation of the circuits. The operation is simply described below. A division ratio is preset in the MC74416 of IC5 to IC7 with a BCD code. The division ratio preset lies between 400 and 799 in relation to digital indication (144.00 ~ 147.99). While, since the IF signal entering the MC 74416 is 5.37 ~ 9.36 MHz to eliminate beat interference in reception, the division ratio must be 537 ~ 936 actually. For this purpose the gate, No, serves to raise the division ratio by 137. The gate circuit, U and D, shifts frequency by ± 600 kHz for repeater operation which is equivalent to the division ratio of 137 ± 60 . MC74416 is a decrement-

ing counter which counts in the order of 0, 4, 3, 2, 1, 0 (5), 4, 3, receiving input pulses, assuming that preset value is 5 and PE is "0" (L level).

But output becomes "1" (H level) only when the count is 0. It means that five input pulses make one output pulse and the frequency is divided to 1/5. With three ICs connected in cascade, the division ratio can be raised up to 999. IC10 is a high speed D-flip-flop which improves the operating frequency of MC74416, 8 MHz (min.), by a factor of two or more with the aid of gates A and B.

Fig. 4 shows the case where the least significant digit of the actual division ratio, N_s , is 7. Although resetting should be done at the rise of input pulse and presetting should be done at the decay of the input pulse when the count has become three, the level at A is set to L at the count of five and it becomes the output of IC10-1 at the next pulse. This output (Q1) resets the MC74416 and presets it to N at the same time, but counting is not performed since PE remains at the L level during the next

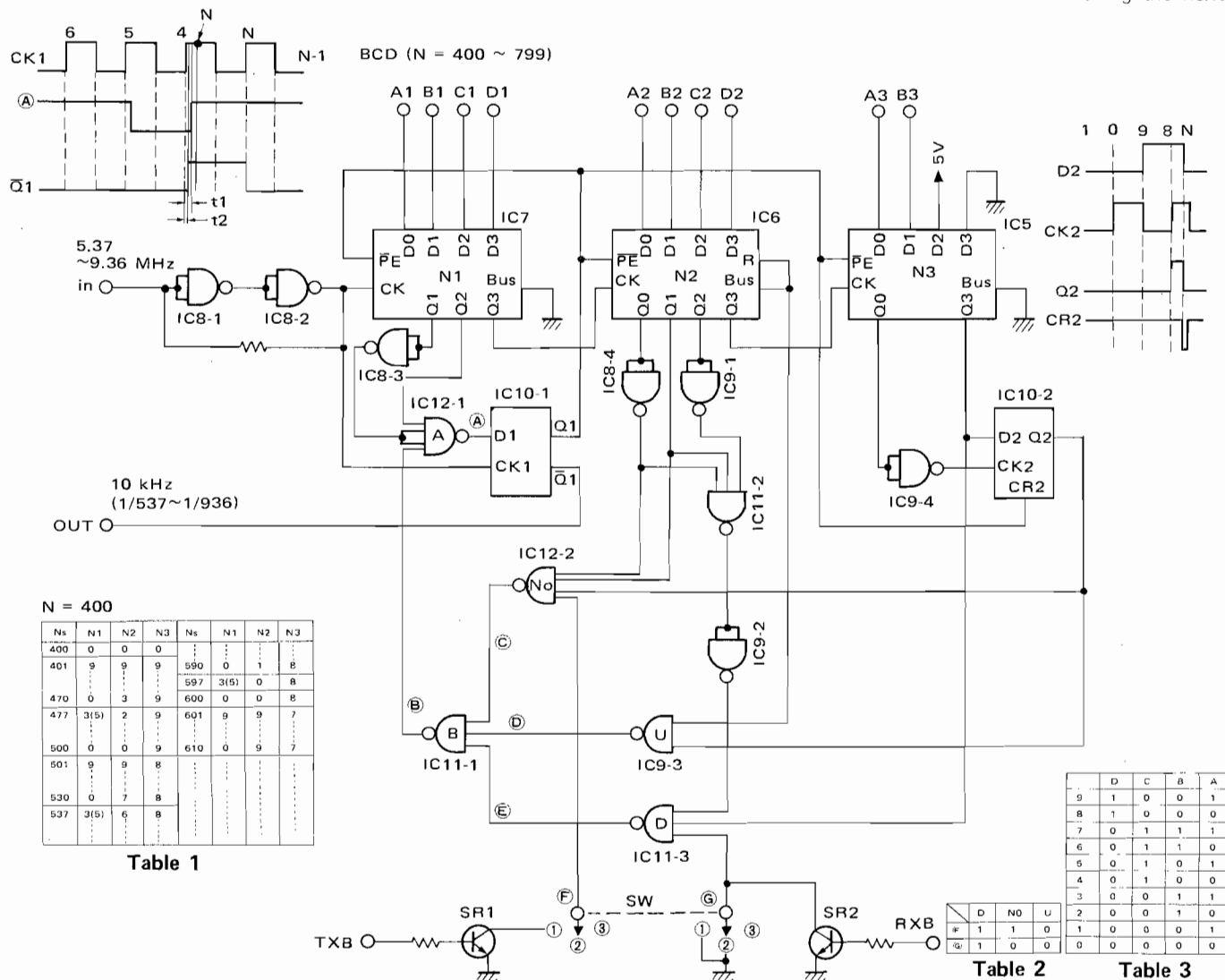

Fig. 4 Block Diagram of PROGRAMMABLE COUNTER and TX-OFFSET Circuit

CIRCUIT DESCRIPTIONS

input pulse and it is reset. The operating frequency has been improved because resetting and presetting are done in one cycle of input pulse but not in half a cycle, and the delay time, t_2 , of the high speed D-flip-flop in IC10 is much smaller than the delay time, t_1 , from IC5, 6 and 7 and logic circuit to point A.

Next, operation is explained in relation to the TX off-set switch setting.

1 +600

During reception, this is the same as in (2). During transmission, SR1 is turned on and becomes U in Table 2. Gate U therefore opens and gates No and D are closed. At this setting, $N_s = N + 197$ ($137 + 60$), and it operates as an extender when IC5, IC6 and IC7 take code 8, 0 and 5 respectively, to perform division of $N + 197$.

2 No (SIMP)

(F) and (G) make up No in Table 2. Gates No and U open and gate D is closed. At this setting, the relation, $N_s = N + 137$, holds between preset value N and actual division ratio N_s . It is enough to decrement the counter after division of N (decrementing) has completed and perform resetting and presetting just when the count has become 137. For this purpose, IC5, IC6 and IC7 do not take code 8, 6 and 3 respectively (as already described), but it operates as an extender at code 5 and performs division of $N + 137$. Since the gate is of code 197 ($137 + 60$), the extender operates before this code triggers the circuitry.

3 -600

During reception, SR2 is turned on as in (2). During transmission, gates No, U and D open as D in Table 2. At this setting, $N_s = N + 77$ ($137 - 60$), it operates as an extender to perform division of $N + 77$ when IC5, IC6 and IC7 carry code 9, 2 and 5 respectively. At this time, the extender operates at code 77 even when all gates are open.

Table 1 shows the case of $N = 400$ (144.00 MHz).

TONE SQUELCH CIRCUIT

Fig. 5 shows the circuit. The tone squelch circuit employed in this equipment is the so-called CTCSS (continuous tone controlled squelch system). Tone signal of a certain frequency is superimposed with audio signal at the transmission side, which is separated at the reception side to drive the squelch circuit. When set to SQU (tone squelch) as shown in Fig. 5, a voltage is applied to TSB1 and TSB2. When no signal is received or signal received does not have tone component, Q20 and Q21 remain off and no sound is reproduced since the voltage of TSB2 is applied to the base of Q13 through D14 and the AF circuit is turned off. When signal including tone component is received, the tone signal separated from discriminator output with Q19, LPF and amplifier, is applied to an active filter. The active filter which serves to the tone frequency and Q11 give steep characteristics at the frequency. It selects tone output equal to the active filter and its output passes through D11 (on during reception) and is detected in D12 and 13. It turns on Q20 and then Q21 and turns off Q13 and the AF circuit (Q14) operates to reproduce sound from speaker. In the AF circuit, an active type high-pass filter of Q24 and 25 cuts off tone signal output to amplify audio signal alone. During transmission, Q22 is turned on, and the active filter and Q11 form an oscillating circuit to deliver output with the same frequency as of the active filter. This output is passed through VR3 and modulated in TX unit together with audiosignal. The maximum frequency deviation for audio signal is ± 5 kHz and that for tone component for tone squelch is ± 0.5 kHz, which results in a ratio of about -20 dB. This would result in buzzing sound when unmodulated signal is received, but a high-pass filter of 300 Hz in cutoff frequency incorporated in the equipment reduces the tone level to prevent buzz. Operation is the same even in the SUB (sub-audible) since a voltage is applied to TSB1, and sub-audible control is performed.

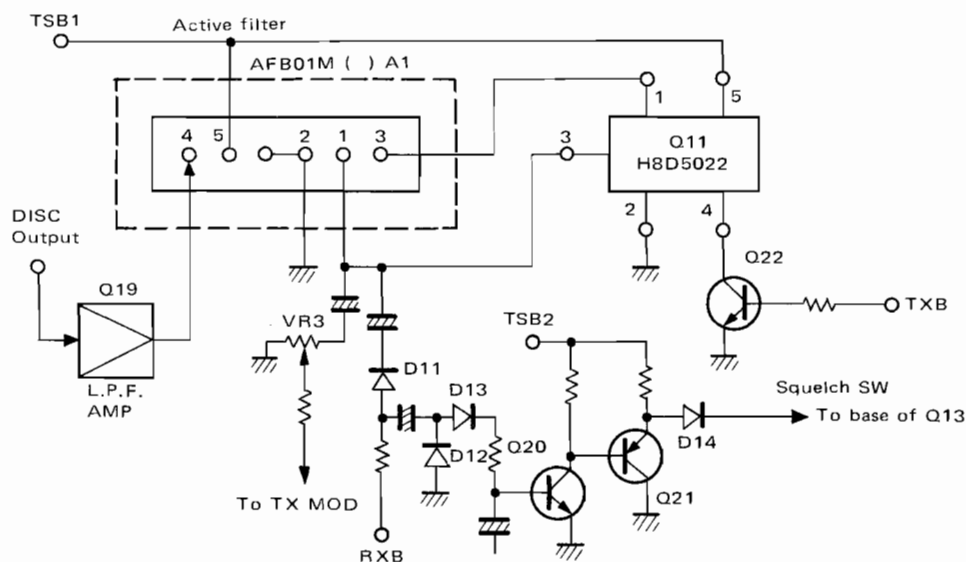

Fig. 5 TONE SQUELCH Circuit

CIRCUIT DESCRIPTION

Table 4 Squelch Active Filter List

Frequency (Hz)	Parts number
88.5	L79-0408-05
94.8	L79-0409-05
100.0	L79-0410-05
103.5	L79-0411-05
107.2	L79-0412-05
110.9	L79-0413-05
114.8	L79-0414-05
118.8	L79-0415-05
128.0	L79-0416-05
127.3	L79-0417-05
131.8	L79-0418-05
136.5	L79-0419-05
141.3	L79-0420-05
146.2	L79-0421-05
151.4	L79-0422-05
156.7	L79-0423-05

VCT CIRCUIT

The equipment incorporates a VCT circuit at the output side of the transmission mixer to improve spurious radiation and output levels in the wide range from 144 to 148 MHz. Varicaps D2, 3 and 4 are connected to tuning coils L11, 12 and 13 through temperature compensation capacitors. Voltages divided from common 9V (C9) with R62 and 61 (145.5 MHz), VR61 (144.5 MHz) VR62 (146.5 MHz) and VR63 (147.5 MHz) and switched with the MHz switch are applied to D2, 3 and 4.

FINAL CIRCUIT

The output of the TX unit (about 1.4 W, 50-ohm load) is amplified to about 10 W (50-ohm load) by Q1 of the PA unit and to about 35 W (50-ohm load) by Q2 and delivered to the ANT terminal by way of an ANT switching diode and a LPF. To protect the final transistor (Q2), the input power to Q2 is limited by controlling the collector voltage of the driver (Q15 of TX unit and Q1 of PA unit) by detecting SWR of antenna with Q3, 10 and 11. When power is low, the circuit is used to reduce the voltage across the SB terminal with VR5.

Large aluminum die-cast heat sinks in combination with Motorola transistors, MRF208 and 2N6083, ensure high reliability.

Table 5 Tone Burst Oscillator Module List

Frequency (Hz)	Parts number
1800	TBM-1800
1950	TBM-1950
2000	TBM-2000
2100	TBM-2100
2150	TBM-2150
2200	TBM-2200
2250	TBM-2250
2400	TBM-2400
2550	TBM-2550

PARTS ALIGNMENT

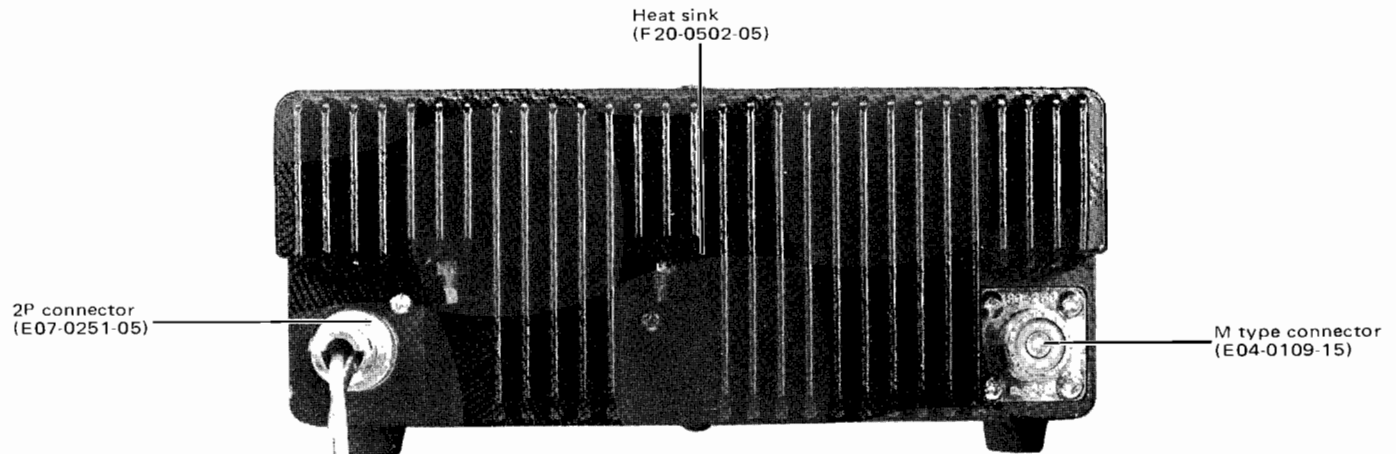
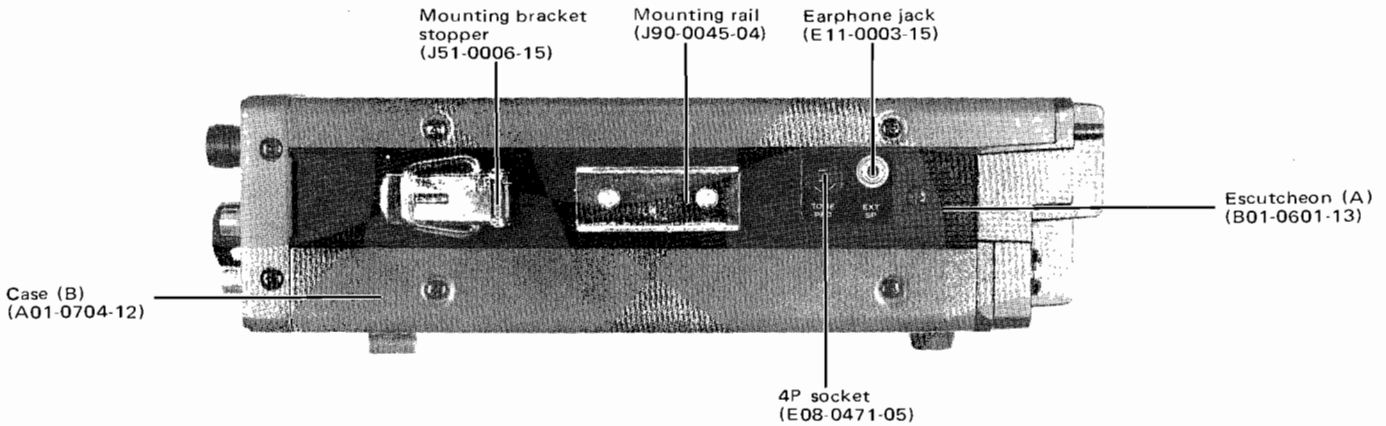
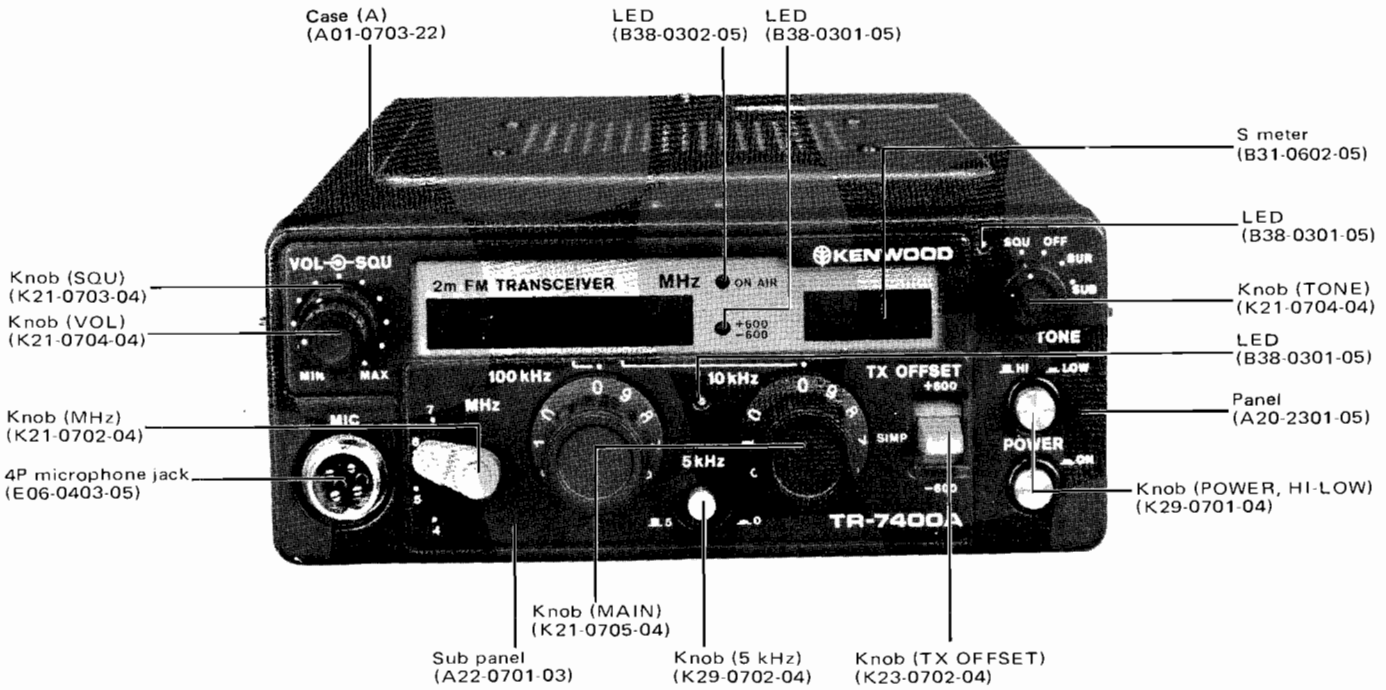

PARTS ALIGNMENT

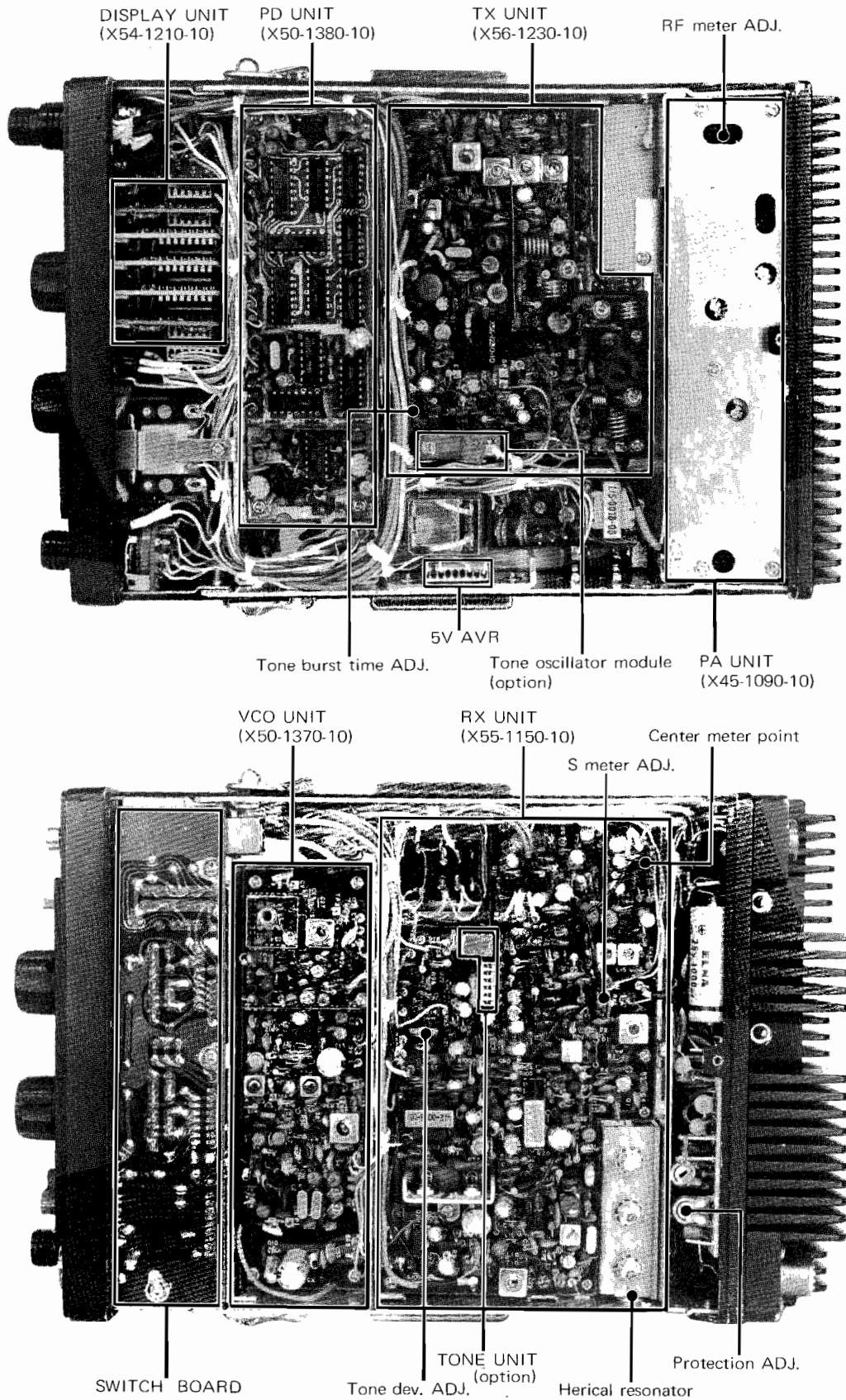

PC BOARD

▼ PA UNIT (X45-1090-10)

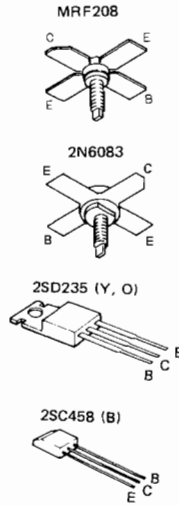
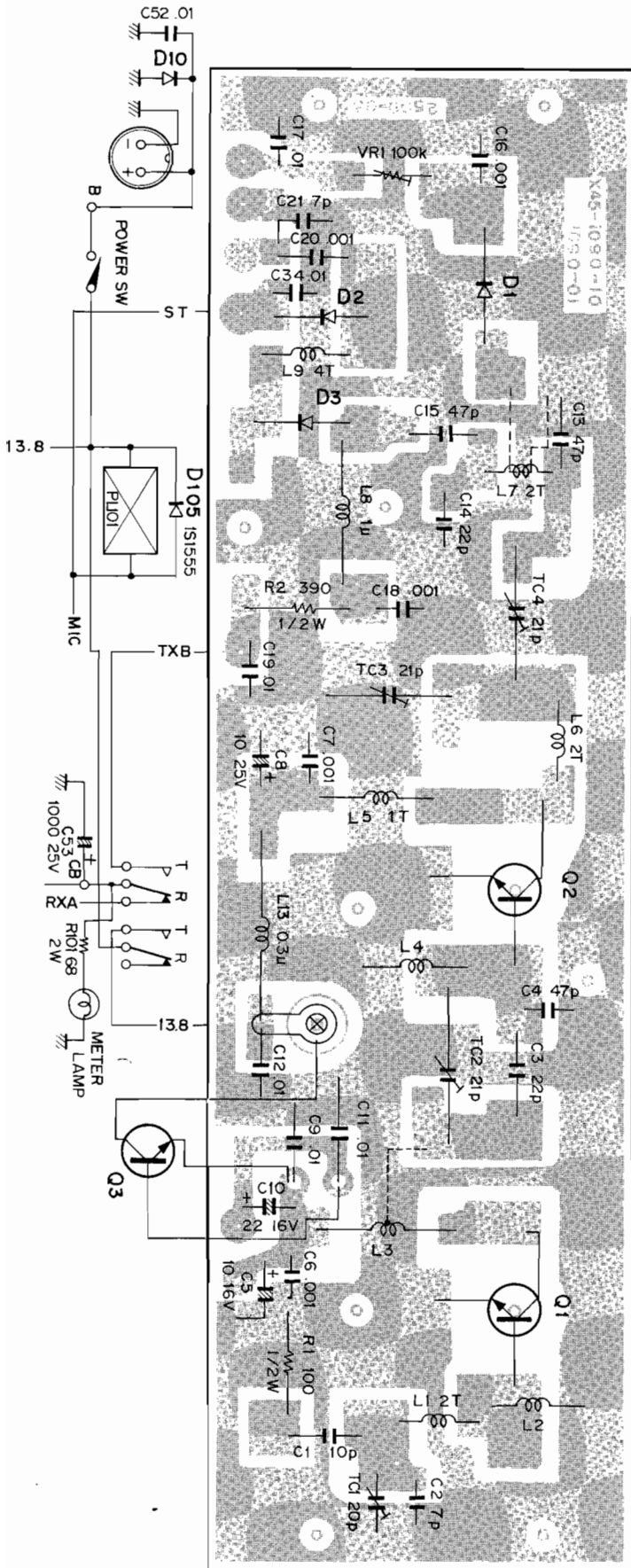

- Q1: MRF208, Q2: 2N6083, Q3: 2SD235 (Y, O),
- Q4: 2SC458 (B), D1, 4: 1N60, D2: M1301,
- D3: M1402, D10: SR3AM-2

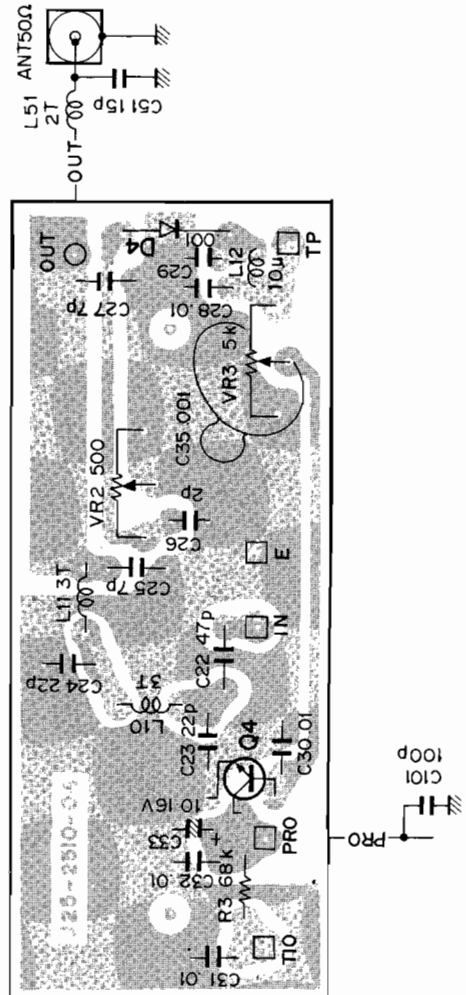

PC BOARD

▼ PD UNIT (X50-1380-10)

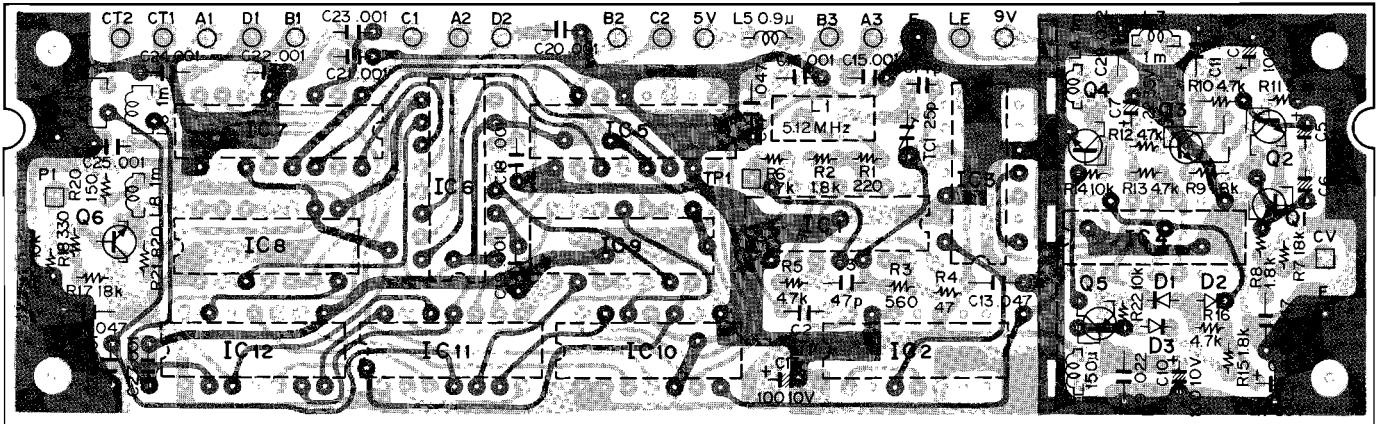

Q1, 2:2SC458 (B), Q3:2SC1345 (E), Q4:2SC733 (Y), Q5:2SA495 (Y), Q6:2SC460 (B), IC1, 8, 9:TD3400AP, IC2, 3:TD3493BP, IC4:MC4044P, IC5~7:MC74416P, IC10:TD3474AP, IC11:TD3410AP, IC12:TD3420AP, D1~3:1S1555

2SC460 (B)
2SC458 (B)
2SC1345 (E)

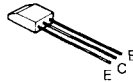

2SC733 (Y)
2SA495 (Y)

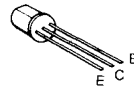

TD3400AP TD3474AP
TD3410AP TD3493BP
TD3420AP MC4044P

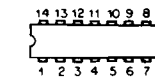

MC74416P

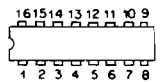

▼ PC BOARD FOR SWITCH (J25-2506-13)

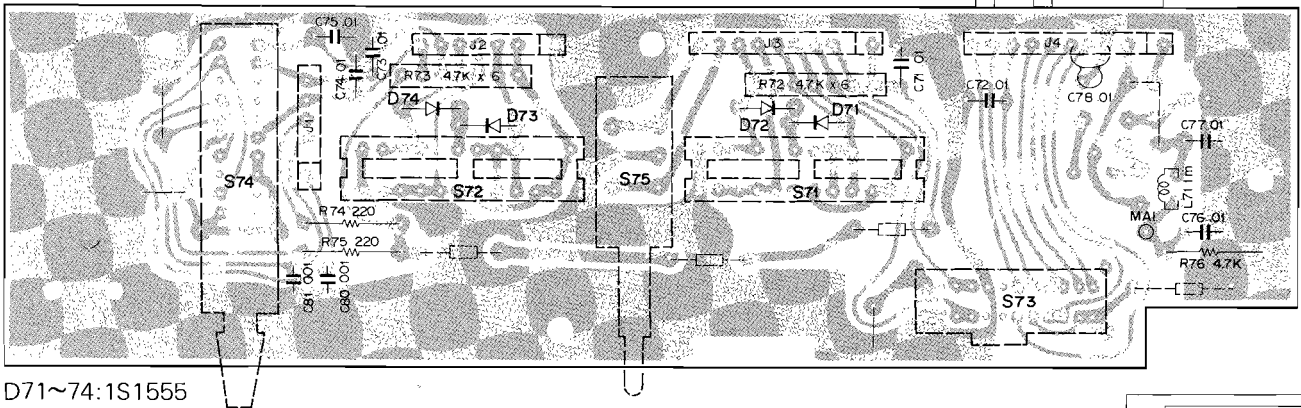

D71~74:1S1555

PC BOARD FOR CHOKE (J25-2507-04) ▶

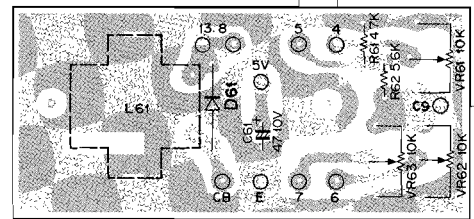

D61:V06B

PC BOARD

▼ VCO UNIT (X50-1370-10)

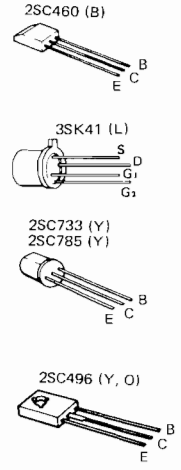
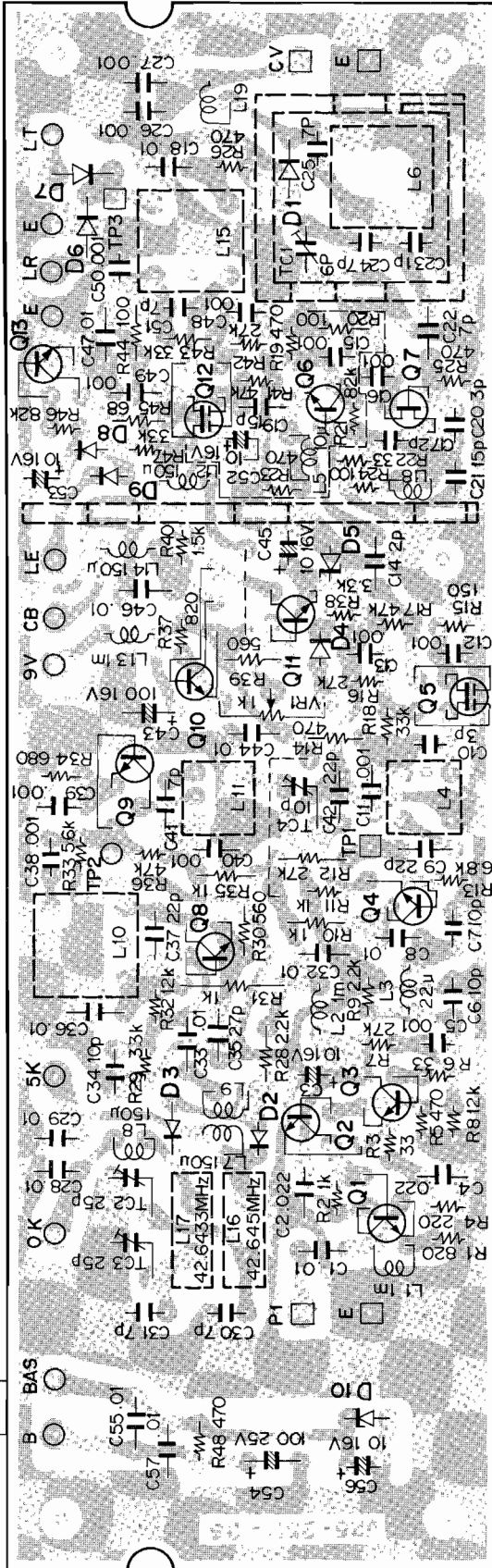
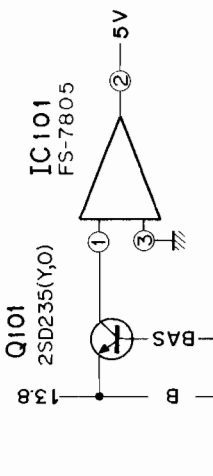

Q1~4: 8: 2SC460 (B), Q5, 12: 3SK41 (L), Q6, 7: 2SC785 (Y), Q10: 2SC496 (Y, O), Q11, 13: 2SC733 (Y),
D1: 1S2094, D2, 3, 6, 7: 1S2588, D4, 8, 9: 1S1555, D5: WZ-061, D10: WZ-090

PC BOARD

▼ INDICATOR UNIT (X54-1210-10)

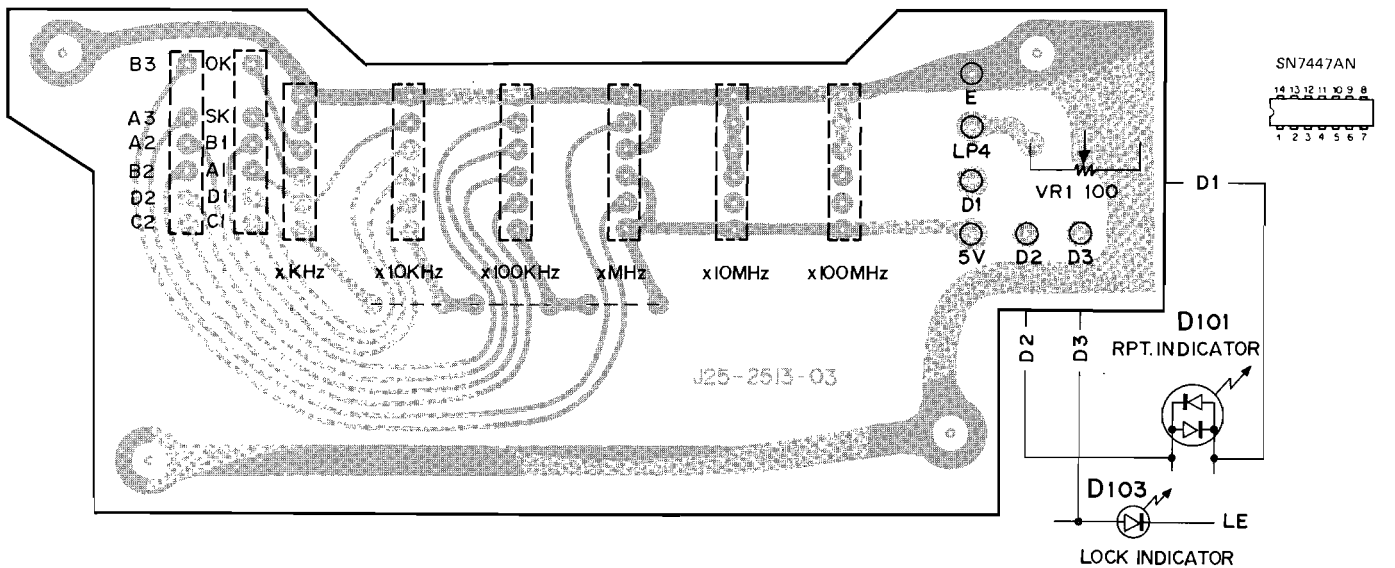
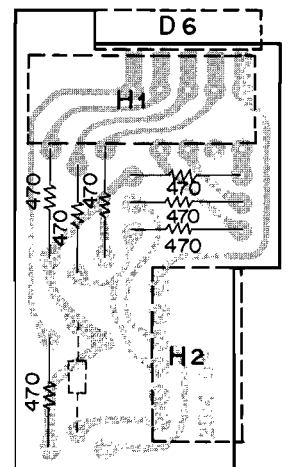
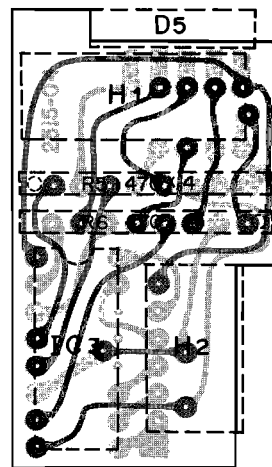
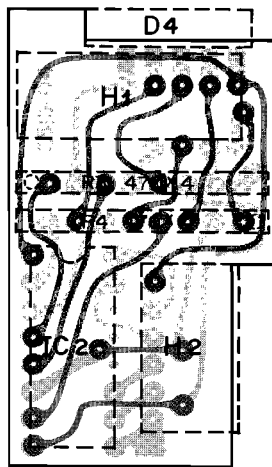
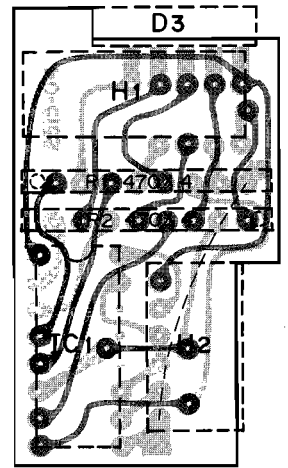
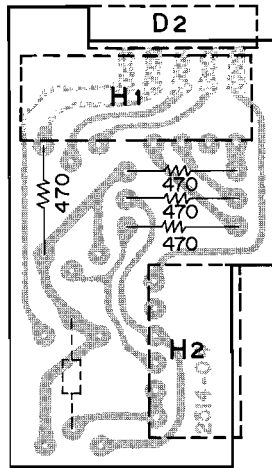
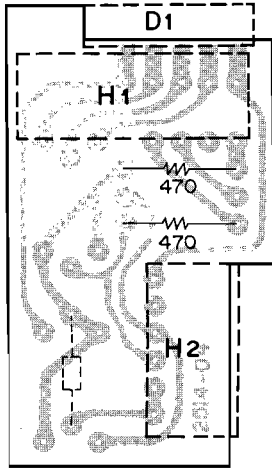

IC1~3:SN7447AN, D1~6:TLR-313 (C, D)

PC BOARD

▼ RX UNIT (X55-1150-10)

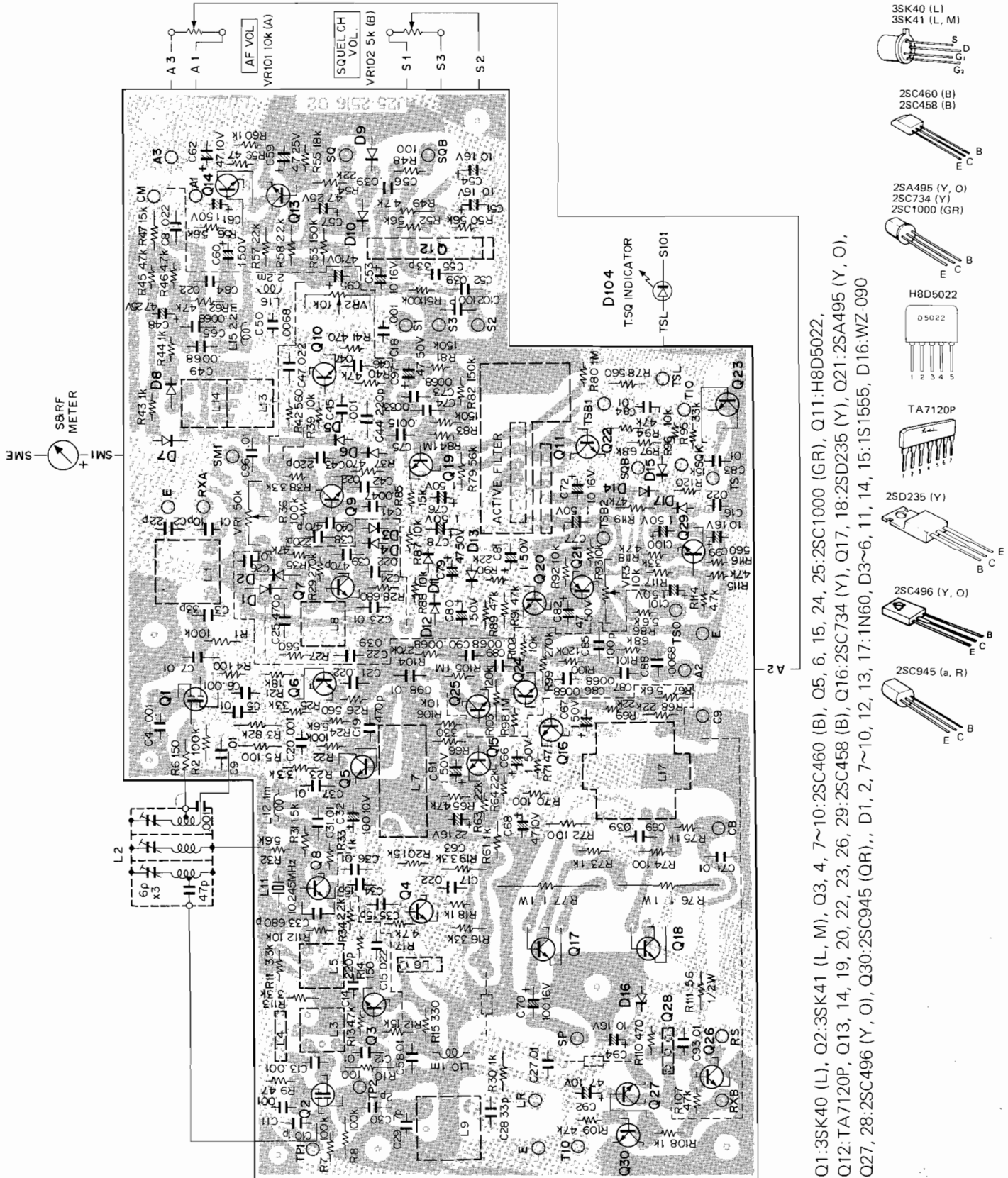

Q1:3SK40 (L), Q2:3SK41 (L, M), Q3, 4, 7~10:2SC460 (B), Q5, 6, 15, 24, 25:2SC1000 (GR), Q11:H8D5022,
 Q12:TA7120P, Q13, 14, 19, 20, 22, 23, 26, 29:2SC458 (B), Q16:2SC734 (Y), Q17, 18:2SD235 (Y), Q21:2SA495 (Y, O),
 Q27, 28:2SC496 (Y, O), Q30:2SC945 (OR), D1, 2, 7~10, 12, 13, 17:1N60, D3~6, 11, 14, 15:1S1555, D16:WZ-090

PC BOARD

▼ TX UNIT (X56-1230-10)

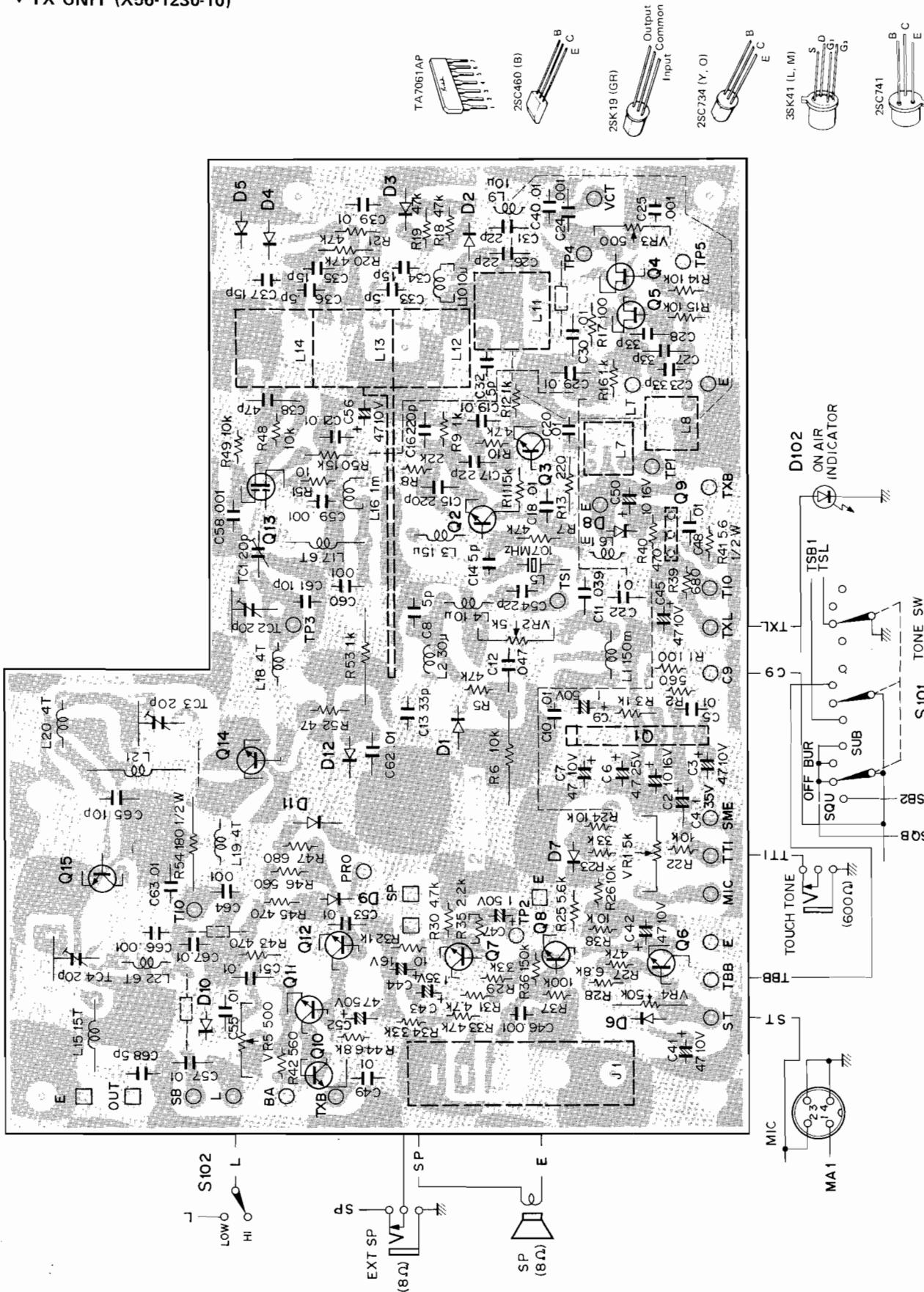

Q1:TA7061AP, Q2, 3:2SC460 (B), Q4, 5:2SK19 (GR), Q6~8:2SC458 (B), Q9:2SC496 (Y, O), Q10:2SA496 (Y, O), Q11, 12:2SC734 (Y, O), Q13:3SK41 (L, M), Q14:2SC741, Q15:2SC908, D1~5:1S2208, D6, 7, 9, 11, 12:1S1555, D8:WZ-061

PARTS LIST

TOTAL

☆ : New parts

Ref. No.	Parts No.	Description	Re- marks	Ref. No.	Parts No.	Description	Re- marks
CAPACITOR							
C61	CE04W1A470	Electrolytic 47 μ F 10WV		—	E18-0802-05	Relay socket	
C71~78	CK45F1H103Z	Ceramic 0.01 μ F +80%, -20%		—	E22-0207-05	Lug	
C80, 81	CK45D1H102M	Ceramic 1000pF \pm 20%		—	E23-0047-04	Terminal x 11	
C82	CK45F1H103Z	Ceramic 0.01 μ F +80%, -20%		—	E30-0355-05	Wire (for speaker)	
C101	CC45SL1H101K	Ceramic 100pF \pm 10%		—	E31-0403-05	Connector with lead	☆
RESISTOR							
R61	RD14CY2E472J	Carbon 4.7k Ω \pm 5% 1/4W		—	E31-0404-15	Connector with lead	☆
R62	RD14CY2E562J	Carbon 5.6k Ω \pm 5% 1/4W		—	E31-0405-05	Connector with lead	☆
R72, 73	R90-0113-06	Resistor Block (4.7k Ω x 6)		—	E31-0406-05	Connector with lead	☆
R74, 75	RD14BY2E221J	Carbon 220 Ω \pm 5% 1/4W		—	E31-0407-05	Connector with lead	☆
R76	RD14BY2E472J	Carbon 4.7k Ω \pm 5% 1/4W		—	E31-0408-05	Connector with lead	☆
R101	RS14AB3D680J	Metal film 68 Ω \pm 5% 2W		—	E31-0409-05	Connector with lead	☆
SEMICONDUCTOR							
Q101	V04-0046-05	Transistor 2SD235 (Y, O)		—	E40-0513-05	Mini connector wafer	
IC101	V30-0158-05	IC FS-7805	☆	—	E40-0616-05	Mini connector housing x 2 Tone filter	
D61	V11-0219-05	Diode V06B		—	E40-0713-05	Mini connector wafer	
D71~74	V11-0076-05	Diode 1S1555		—	E40-0913-05	Mini connector wafer	
D101	B38-0301-05	LED with holder	☆	—	E40-1013-05	Mini connector wafer	
D102~104	B38-0302-05	LED with holder	☆	—	F05-1031-05	Fuse (10A) x 2	
D105	V11-0076-05	Diode 1S1555		—	F19-0601-14	Blinding plate A (Inside)	☆
POTENTIOMETER							
VR61~63	R12-3025-05	Semi-fixed resistor 10k Ω		—	F19-0602-04	Blinding plate B (Outside)	☆
VR101,102	R19-9401-05	Variable resistor	☆	—	F20-0078-05	Insulating plate	
SWITCH/RELAY							
S71, 72	S29-2401-05	Rotary switch (CHANNEL)	☆	—	F29-0014-05	Insulating washer	
S73	S29-0402-05	Rotary switch (MHZ)	☆	—	G11-0008-04	Cushion	
S74	S33-4401-05	Lever switch (TX OFFSET)	☆	—	G11-0604-04	Cushion	☆
S75	S40-2059-05	Push switch (5 kHz)		—	G13-0014-04	Vibration protector (rubber)	
S101	S29-0401-05	Rotary switch (TONE)	☆	—	H01-2510-03	Case (inside)	☆
S102	S40-2060-05	Push switch (HI-LOW)		—	H10-1206-14	Buffer fixture	
S103	S59-2029-05	Push switch (POWER)		—	H10-2501-03	Styrene foam cushion (Upper)	☆
RL101	S51-2012-05	Relay		—	H10-2502-02	Styrene foam cushion (Lower)	☆
COIL							
L61	L15-0016-05	Choke coil (Low frequency)		—	H20-1401-13	Protection cover	☆
L71	L40-1021-03	Ferri inductor 1mH		—	H25-0029-04	Polyethylene bag (60 x 110 mm)	
MISCELLANEOUS							
—	A01-0703-02	Case (A)	☆	—	H25-0079-04	Polyethylene bag (200 x 200 mm)	
—	A01-0704-12	Case (B)	☆	—	H25-0103-04	Polyethylene bag (125 x 250 mm)	
—	A10-1201-32	Chassis	☆	—	J01-0021-04	Leg	
—	A20-2301-05	Panel	☆	—	J02-0069-05	Leg (rubber) x 2	
—	A22-0701-03	Sub panel	☆	—	J13-0029-05	Fuse holder	
—	B01-0601-13	Escutcheon(A) (Right toward you)	☆	—	J21-0941-02	Mounting bracket	
—	B01-0602-03	Escutcheon(B) (Left toward you)	☆	—	J25-2506-13	PC board (for switch)	☆
—	B05-0701-04	Speaker grille cloth	☆	—	J25-2507-04	PC board (for choke)	☆
—	B10-0601-14	Front glass	☆	—	J25-2508-04	PC board (for TS)	☆
—	B31-0602-05	S meter	☆	—	J32-0029-04	Hexagonal boss x 3 (PC board for choke)	
—	B40-2403-04	Model name plate	☆	—	J32-0217-04	Hexagonal boss x 4 (PLL)	
—	B41-0605-04	Name plate (terminal)	☆	—	J32-0704-04	Hexagonal boss x 5 (for S74)	☆
—	B42-1602-04	Label	☆	—	J41-0020-04	Knob bushing x 2	
—	B46-0058-00	Warranty card		—	J51-0006-15	Mounting bracket stopper x 2	
—	B50-2515-00	Operating manual	☆	—	J90-0045-04	Mounting rail x 2	
—	E06-0403-05	4P microphone jack		—	K21-0702-04	Knob (MHZ)	
—	E07-0251-05	2P connector (plug)	☆	—	K21-0703-04	Knob (SQ)	
—	E08-0471-05	4P socket	☆	—	K21-0704-04	Knob (AF, TONE) x 2	
—	E09-0471-05	4P plug	☆	—	K21-0705-04	Knob (MAIN) x 2	
—	E11-0003-15	Phone jack		—	K23-0702-04	Knob (TX OFFSET)	
—	E12-0001-05	Phone plug		—	K29-0701-04	Knob (HI-LOW, POWER) x 2	
—				—	K29-0702-04	Knob (5 kHz)	
—				—	T03-0027-15	Speaker	
—				—	T31-0302-05	Microphone	
—				—	X45-1090-10	PA unit	☆
—				—	X50-1370-10	VCO unit	☆
—				—	X50-1380-10	PD unit	☆
—				—	X54-1210-10	Indicator unit	☆
—				—	X55-1150-10	RX unit	☆
—				—	X56-1230-10	TX unit	☆

PARTS LIST

PA UNIT (X45-1090-10)

Parts No.	Ref. No.	Description	Re- marks
CAPACITOR			
C1	CK45SL2H100D	Ceramic 10pF ± 0.5pF	
C2	CK45SL2H070D	Ceramic 7pF ± 0.5pF	
C3	CC45CH2H220J	Ceramic 22pF ± 5%	
C4	CC45CH2H470K	Ceramic 47pF ± 10%	
C5	CE04W1C100	Electrolytic 10μF 16WV	
C6, 7	CK45D1H102M	Ceramic 1000pF ± 20%	
C8	CE04W1E100	Electrolytic 10μF 25WV	
C9	CK45F1H103Z	Ceramic 0.01μF +80%, -20%	
C10	CE04W1C220	Electrolytic 22μF 16WV	
C11, 12	CK45F1H103Z	Ceramic 0.01μF +80%, -20%	
C13	CC45SL2H470K	Ceramic 47pF ± 10%	
C14	CC45SL2H220J	Ceramic 22pF ± 5%	
C15	CC45SL2H470K	Ceramic 47pF ± 10%	
C16	CK45D1H102M	Ceramic 1000pF ± 20%	
C17	CK45F1H103Z	Ceramic 0.01μF +80%, -20%	
C18	CK45D1H102M	Ceramic 1000pF ± 20%	
C19	CK45F1H103Z	Ceramic 0.01μF +80%, -20%	
C20	CK45D1H102M	Ceramic 1000pF ± 20%	
C21	CK45SL2H070D	Ceramic 7pF ± 0.5pF	
C22	CK45SL2H470K	Ceramic 47pF ± 10%	
C23, 24	CK45SL2H220J	Ceramic 22pF ± 5%	
C25	CK45SL2H070D	Ceramic 7pF ± 0.5pF	
C26	CK45SL1H020C	Ceramic 2pF ± 0.25pF	
C27	CK45SL2H070D	Ceramic 7pF ± 0.5pF	
C28	CK45F1H103Z	Ceramic 0.01μF +80%, -20%	
C29	CK45D1H102M	Ceramic 1000pF ± 20%	
C30~32	CK45F1H103Z	Ceramic 0.01μF +80%, -20%	
C33	CE04W1C100	Electrolytic 10μF 10WV	
C34	CK45F1H103Z	Ceramic 0.01μF +80%, -20%	
C35	CK45D1H102M	Ceramic 1000pF ± 20%	
C51	CK45SL2H150J	Ceramic 15pF ± 5%	
C52	CK45F1H103Z	Ceramic 0.01μF +80%, -20%	
C53	CE02W1E102	Electrolytic 1000μF 25WV	
RESISTOR			
R1	RC05GF2H101J	Carbon 100Ω ± 5% 1/2W	
R2	RC05GF2H391J	Carbon 390Ω ± 5% 1/2W	
R3	RD14CY2E683J	Carbon 68kΩ ± 5% 1/4W	
POTENTIOMETER			
VR1	R12-5024-05	Semi-fixed resistor 100kΩ	
VR2	R12-0042-05	Semi-fixed resistor 500Ω	
VR3	R12-2015-05	Semi-fixed resistor 5kΩ	
TC1	C05-0013-15	Ceramic trimmer	
TC2~4	C02-0002-05	Midget variable capacitor	
SEMICONDUCTOR			
Q1	V30-0224-05	Transistor MRF208	☆
Q2	V30-0225-05	Transistor 2N6083	☆
Q3	V04-0046-05	Transistor 2SD235 (Y, O)	
Q4	V03-0093-05	Transistor 2SC458 (B)	
D1	V11-0051-05	Diode 1N60	
D2	V11-0255-05	Diode M1301	
D3	V11-5260-16	Diode M1402	☆
D4	V11-0051-05	Diode 1N60	
D10	V11-0171-05	Diode SR3AM-2	

Ref. No.	Parts No.	Description	Re- marks
COIL			
L1	L34-0426-05	VHF coil (6φ 2T)	
L2	L33-0604-05	Choke coil with 47Ω	☆
L3	L34-0478-05	VHF coil (8φ 5T)	
L4	L33-0173-05	Choke coil with 100Ω	
L5	L34-0605-05	VHF coil (8φ 1T)	☆
L6	L34-0624-05	VHF coil (8φ 2T)	☆
L7	L34-0604-05	VHF coil (8φ 2T)	☆
L8	L33-0025-05	Choke coil 1μH	
L9	L34-0464-05	VHF coil (6φ 4T)	
L10, 11	L34-0430-05	VHF coil (6φ 3T)	
L12	L40-1001-03	Ferri-inductor (10 mH)	
L13	L33-0074-05	Choke coil (0.3μH)	
L51	L34-0604-05	VHF coil (8φ 2T)	☆
MISCELLANEOUS			
—	E04-0109-15	M type connector	
—	E06-0251-05	2P connector (jack)	☆
—	E22-0207-05	Lug	
—	E23-0015-04	Earth lug x 2	
—	E23-0046-04	Terminal x 12	
—	E23-0047-04	Terminal	
—	E30-0234-15	Lead wire	
—	F20-0078-05	Insulating plate	
—	F20-0502-05	Heat sink	☆
—	J32-0703-14	Hexagonal boss x 5	☆

VCO UNIT (X50-1370-10)

Ref. No.	Parts No.	Description	Re- marks
CAPACITOR			
C1	CQ92M1H103K	Mylar 0.01μF ± 10%	
C2	CQ92M1H223K	Mylar 0.022μF ± 10%	
C3	CE04W1C100	Electrolytic 10μF 16WV	
C4	CQ92M1H223K	Mylar 0.022μF ± 10%	
C5	CQ92M1H102K	Mylar 1000pF ± 10%	
C6, 7	CC45CH1H100D	Ceramic 10pF ± 0.5pF	
C8	CQ92M1H103K	Mylar 0.01μF ± 10%	
C9	CC45SL1H220J	Ceramic 22pF ± 5%	
C10	CC45TH1H030C	Ceramic 3pF ± 0.25pF	
C11~13	CK45D1H102M	Ceramic 1000pF ± 20%	
C14	CC45SL1H020C	Ceramic 2pF ± 0.25pF	
C15, 16	CK45D1H102M	Ceramic 1000pF ± 20%	
C17	CC45CH1H020C	Ceramic 2pF ± 0.25pF	
C18	CK45F1H103Z	Ceramic 0.01μF +80%, -20%	
C19	CC45SL1H150J	Ceramic 15pF ± 5%	
C20	CC45CH1H030C	Ceramic 3pF ± 0.25pF	
C21	CC45CH1H150J	Ceramic 15pF ± 5%	
C22	CC45RH1H070C	Ceramic 7pF ± 0.25pF	
C23	CC45TH1H010C	Ceramic 1pF ± 0.25pF	
C24, 25	CC45TH1H070D	Ceramic 7pF ± 0.5pF	
C26, 27	CK45B1H102K	Ceramic 1000pF ± 10%	
C28, 29	CK45F1H103Z	Ceramic 0.01μF +80%, -20%	
C30, 31	CC45SL1H070D	Ceramic 7pF ± 0.5pF	
C32, 33	CK45F1H103Z	Ceramic 0.01μF +80%, -20%	
C34	CC45CH1H100D	Ceramic 10pF ± 0.5pF	
C35	CC45CH1H270J	Ceramic 27pF ± 5%	
C36	CK45F1H103Z	Ceramic 0.01μF +80%, -20%	
C37	CC45RH1H220J	Ceramic 22pF ± 5%	
C38~40	CK45D1H102M	Ceramic 1000pF ± 20%	
C41	CC45RH1H070D	Ceramic 7pF ± 0.5pF	
C42	CC45SL1H220J	Ceramic 22pF ± 5%	
C43	CE04W1C101	Electrolytic 100μF 16WV	
C44	CK45F1H103Z	Ceramic 0.01μF +80%, -20%	
C45	CE04W1C100	Electrolytic 10μF 16WV	

PARTS LIST

Ref. No.	Parts No.	Description	Re- marks
C46, 47	CK45F1H103Z	Ceramic 0.01 μ F +80%, -20%	
C48~50	CK45D1H102M	Ceramic 1000pF \pm 20%	
C51	CC45RH1H070D	Ceramic 7pF \pm 0.5pF	
C52, 53	CE04W1C100	Electrolytic 10 μ F 16WV	
C54	CE04W1E101	Electrolytic 100 μ F 25WV	
C55	CK45F1H103Z	Ceramic 0.01 μ F +80%, -20%	
C56	CE04W1C100	Electrolytic 10 μ F 16WV	
C57	CK45F1H103Z	Ceramic 0.01 μ F +80%, -20%	

RESISTOR

R1	RD14CY2B821J	Carbon 820 Ω \pm 5% 1/8W	
R2	RD14CY2B102J	Carbon 1k Ω \pm 5% 1/8W	
R3	RD14CY2B330J	Carbon 33 Ω \pm 5% 1/8W	
R4	RD14CY2B221J	Carbon 220 Ω \pm 5% 1/8W	
R5	RD14CY2B471J	Carbon 470 Ω \pm 5% 1/8W	
R6	RD14CY2B330J	Carbon 33 Ω \pm 5% 1/8W	
R7	RD14CY2B273J	Carbon 27k Ω \pm 5% 1/8W	
R8	RD14CY2B123J	Carbon 12k Ω \pm 5% 1/8W	
R9	RD14CY2B222J	Carbon 2.2k Ω \pm 5% 1/8W	
R10,11	RD14CY2B102J	Carbon 1k Ω \pm 5% 1/8W	
R12	RD14CY2B273J	Carbon 27k Ω \pm 5% 1/8W	
R13	RD14CY2B682J	Carbon 6.8k Ω \pm 5% 1/8W	
R14	RD14CY2B471J	Carbon 470 Ω \pm 5% 1/8W	
R15	RD14CY2B151J	Carbon 150 Ω \pm 5% 1/8W	
R16	RD14CY2B273J	Carbon 27k Ω \pm 5% 1/8W	
R17	RD14CY2B473J	Carbon 47k Ω \pm 5% 1/8W	
R18	RD14CY2B333J	Carbon 33k Ω \pm 5% 1/8W	
R19	RD14CY2B471J	Carbon 470 Ω \pm 5% 1/8W	
R20	RD14CY2B101J	Carbon 100 Ω \pm 5% 1/8W	
R21	RD14CY2B823J	Carbon 82k Ω \pm 5% 1/8W	
R22	RD14CY2B330J	Carbon 33 Ω \pm 5% 1/8W	
R23	RD14CY2B471J	Carbon 470 Ω \pm 5% 1/8W	
R24	RD14CY2B101J	Carbon 100 Ω \pm 5% 1/8W	
R25	RD14CY2E471J	Carbon 470 Ω \pm 5% 1/4W	
R26	RD14CY2B471J	Carbon 470 Ω \pm 5% 1/8W	
R28	RD14CY2B222J	Carbon 2.2k Ω \pm 5% 1/8W	
R29	RD14CY2B332J	Carbon 3.3k Ω \pm 5% 1/8W	
R30	RD14CY2B561J	Carbon 560 Ω \pm 5% 1/8W	
R31	RD14CY2B102J	Carbon 1k Ω \pm 5% 1/8W	
R32	RD14CY2B123J	Carbon 12k Ω \pm 5% 1/8W	
R33	RD14CY2B562J	Carbon 5.6k Ω \pm 5% 1/8W	
R34	RD14CY2B681J	Carbon 680 Ω \pm 5% 1/8W	
R35	RD14CY2B102J	Carbon 1k Ω \pm 5% 1/8W	
R36	RD14CY2B473J	Carbon 47k Ω \pm 5% 1/8W	
R37	RD14CY2B821J	Carbon 820 Ω \pm 5% 1/8W	
R38	RD14CY2B332J	Carbon 3.3k Ω \pm 5% 1/8W	
R39	RD14CY2B561J	Carbon 560 Ω \pm 5% 1/8W	
R40	RD14CY2B152J	Carbon 1.5k Ω \pm 5% 1/8W	
R41	RD14CY2B473J	Carbon 47k Ω \pm 5% 1/8W	
R42	RD14CY2B273J	Carbon 27k Ω \pm 5% 1/8W	
R43	RD14CY2B333J	Carbon 33k Ω \pm 5% 1/8W	
R44	RD14CY2B101J	Carbon 100 Ω \pm 5% 1/8W	
R45	RD14CY2B680J	Carbon 68 Ω \pm 5% 1/8W	
R46	RD14CY2B822J	Carbon 8.2k Ω \pm 5% 1/8W	
R47	RD14CY2B333J	Carbon 33k Ω \pm 5% 1/8W	
R48	RD14CY2E471J	Carbon 470 Ω \pm 5% 1/4W	

POTENTIOMETER

VR1	R12-1020-05	Semi-fixed resistor 1k Ω	
TC1	C05-0062-05	Ceramic trimmer	
TC2, 3	C05-0067-05	Ceramic trimmer	
TC4	C05-0031-15	Ceramic trimmer	

SEMICONDUCTOR

Q1~4	V03-0079-05	Transistor 2SC460 (B)	
Q5	V09-0057-05	FET 3SK41 (L)	
Q6	V03-0253-05	Transistor 2SC785 (O)	
Q7	V09-0012-05	FET 2SK19 (GR)	
Q8, 9	V03-0079-05	Transistor 2SC460 (B)	

Ref. No.	Parts No.	Description	Re- marks
Q10	V03-0336-05	Transistor 2SC496 (Y, O)	
Q11	V03-0123-05	Transistor 2SC733 (Y)	
Q12	V09-0057-05	FET 3SK41 (L)	
Q13	V03-0123-05	Transistor 2SC733 (Y)	
D1	V11-0447-05	Diode 1SV50S	☆
D2, 3	V11-0414-05	Diode 1S2588	
D4	V11-0076-05	Diode 1S1555	
D5	V11-0243-05	Zener diode WZ-061	
D6, 7	V11-0414-05	Diode 1S2588	
D8, 9	V11-0076-05	Diode 1S1555	
D10	V11-0240-05	Zener diode WZ-090	

COIL/X'TAL

L1, 2	L40-1021-03	Ferri-inductor	
L3	L40-2201-03	Ferri-inductor	
L4	L31-0347-05	Tuning coil (for 135 MHz)	
L5	L40-1001-03	Ferri-inductor	
L6	L32-0601-05	OSC coil (for VCO)	☆
L7, 8	L40-1511-03	Ferri-inductor	
L9	L33-0605-05	Choke coil 0.47 μ H	☆
L10	L32-0002-05	OSC coil (for 42 MHz)	
L11	L31-0347-05	Tuning coil (for 135 MHz)	
L12	L40-1511-03	Ferri-inductor	
L13	L40-1021-03	Ferri-inductor	
L14	L40-1511-03	Ferri-inductor	
L15	L31-0180-05	Tuning coil (for 135 MHz)	
L16	L77-0712-05	Crystal oscillator 42.645 MHz	☆
L17	L77-0711-05	Crystal oscillator 42.6433 MHz	☆
L18, 19	L40-3391-03	Ferri-inductor	

MISCELLANEOUS

-	E23-0046-04	Terminal x 7	
-	E23-0047-04	Terminal x 11	

PD UNIT (X50-1380-10)

Ref. No.	Parts No.	Description	Re- marks
CAPACITOR			
C1	CC45SL1H070D	Ceramic 7pF \pm 0.5pF	
C2, 3	CC45SL1H470K	Ceramic 47pF \pm 10%	
C4	C90-0262-05	Ceramic 0.047 μ F	
C5, 6	CS15E1C2R2M	Tantalum 2.2 μ F 16WV	
C7	CS15E1VR22M	Tantalum 0.22 μ F 35WV	
C8	CE04W1HR47	Electrolytic 0.47 μ F 50WV	
C9	C90-0254-05	Ceramic 0.022 μ F	
C10	CE04W1A101	Electrolytic 100 μ F 10WV	
C11	C90-0254-05	Ceramic 0.022 μ F	
C12	CE04W1A101	Electrolytic 100 μ F 10WV	
C13, 14	C90-0262-05	Ceramic 0.047 μ F	
C15, 16	CK45D1H102M	Ceramic 1000pF \pm 20%	
C17	CE04W1A101	Electrolytic 100 μ F 10WV	
C18~25	CK45D1H102M	Ceramic 1000pF \pm 20%	
C26	C90-0262-05	Ceramic 0.047 μ F	
C27, 28	CK45D1H102M	Ceramic 1000pF \pm 20%	

RESISTOR

R1	RD14CY2B221J	Carbon 220 Ω \pm 5% 1/8W	
R2	RD14CY2B182J	Carbon 1.8k Ω \pm 5% 1/8W	
R3	RD14CY2B561J	Carbon 560 Ω \pm 5% 1/8W	
R4	RD14CY2B470J	Carbon 47 Ω \pm 5% 1/8W	
R5, 6	RD14CY2B472J	Carbon 4.7k Ω \pm 5% 1/8W	
R7	RD14CY2B183J	Carbon 18k Ω \pm 5% 1/8W	
R8, 9	RD14CY2B182J	Carbon 1.8k Ω \pm 5% 1/8W	
R10	RD14CY2B472J	Carbon 4.7k Ω \pm 5% 1/8W	
R11	RD14CY2B332J	Carbon 3.3k Ω \pm 5% 1/8W	
R12, 13	RD14CY2B472J	Carbon 4.7k Ω \pm 5% 1/8W	
R14	RD14CY2B103J	Carbon 10k Ω \pm 5% 1/8W	
R15	RD14CY2B182J	Carbon 1.8k Ω \pm 5% 1/8W	

PARTS LIST

Ref. No.	Parts No.	Description	Re- marks
R16	RD14CY2B472J	Carbon 4.7k Ω \pm 5% 1/8W	
R17	RD14CY2B183J	Carbon 18k Ω \pm 5% 1/8W	
R18	RD14CY2B331J	Carbon 330 Ω \pm 5% 1/8W	
R19	RD14CY2B103J	Carbon 10k Ω \pm 5% 1/8W	
R20	RD14CY2B151J	Carbon 150 Ω \pm 5% 1/8W	
R21	RD14CY2B821J	Carbon 820 Ω \pm 5% 1/8W	
R22	RD14CY2B103J	Carbon 10k Ω \pm 5% 1/8W	
SEMICONDUCTOR			
Q1, 2	V03-0093-05	Transistor 2SC458 (B)	
Q3	V03-0281-05	Transistor 2SC1345 (E)	
Q4	V03-0123-05	Transistor 2SC733 (Y)	
Q5	V01-0037-05	Transistor 2SA495 (Y)	
Q6	V03-0079-05	Transistor 2SC460 (B)	
IC1	V30-0132-05	IC TD3400AP	
IC2, 3	V30-0238-05	IC TD3493BP	☆
IC4	V30-0173-05	IC MC4044P	
IC5~7	V30-0201-05	IC MC4016P(MC74416P)	☆
IC8, 9	V30-0132-05	IC TD3400AP	
IC10	V30-0237-05	IC TD3474AP	☆
IC11	V30-0159-05	IC TD3410AP	☆
IC12	V30-0236-05	IC TD3420AP	☆
D1~3	V11-0076-05	Diode 1S1555	
TRIMMER/COIL/X'TAL			
TC1	C05-0067-05	Ceramic trimmer 25pF	
L1	L77-0713-05	Crystal oscillator 5.12 MHz	☆
L2	L40-1511-03	Ferri-inductor	
L3, 4	L40-1021-03	Ferri-inductor	
L5	L34-0438-05	Coil 0.9 μ H	
L6~8	L40-1021-03	Ferri-inductor	
MISCELLANEOUS			
—	E23-0046-04	Terminal x 5	☆
—	E23-0047-04	Terminal x 16	

INDICATOR UNIT (X54-1210-10)

Ref. No.	Parts No.	Description	Re- marks
R1~6	R90-0510-05	Resistor block 470 Ω x 4	☆
—	RD14BY2B471J	Carbon 470 Ω \pm 5% 1/8W x13	
VR1	R12-0048-05	Semi-fixed resistor 100 Ω	
IC1~3	V30-0195-05	IC SN7447AN	☆
D1~6	V11-0458-05	LED TLR-313 (C, D)	☆
—	E02-0101-05	IC socket x 6	
—	E23-0047-04	Terminal x 6	
—	E40-0611-05	Mini connector wafer x 6	
—	E40-0613-05	Mini connector wafer x 2	
—	E40-0616-05	Mini connector housing x 6	

RX UNIT (X55-1150-10)

Ref. No.	Parts No.	Description	Re- marks
CAPACITOR			
C1	CC45CH1H100D	Ceramic 10pF \pm 0.5pF	
C2	CC45CH1H220J	Ceramic 22pF \pm 5%	
C3	CC45CH1H330J	Ceramic 33pF \pm 5%	
C4	CK45D1H102M	Ceramic 1000pF \pm 20%	
C5	CK45F1H103Z	Ceramic 0.01 μ F +80%, -20%	
C6	CK45D1H102M	Ceramic 1000pF \pm 20%	
C7	CQ92M1H103K	Mylar 0.01 μ F \pm 10%	

Ref. No.	Parts No.	Description	Re- marks
C8	CQ92M1H223K	Mylar 0.022 μ F \pm 10%	
C9	CK45F1H103Z	Ceramic 0.01 μ F +80%, -20%	
C10	CC45SL1H010C	Ceramic 1pF \pm 0.25pF	
C11	CK45D1H102M	Ceramic 1000pF \pm 20%	
C12	CK45F1H103Z	Ceramic 0.01 μ F +80%, -20%	
C13	CK45D1H102M	Ceramic 1000pF \pm 20%	
C14	CC45SL1H221K	Ceramic 220pF \pm 10%	
C15	CQ92M1H223K	Mylar 0.022 μ F \pm 10%	
C16, 17	CQ92M1H223K	Mylar 0.022 μ F \pm 10%	
C18	CK45D1H102M	Ceramic 1000pF \pm 20%	
C19	CK45B1H471K	Ceramic 470pF \pm 10%	
C20	CQ92M1H102K	Mylar 1000pF \pm 10%	
C21	CQ92M1H223K	Mylar 0.022 μ F \pm 10%	
C22	CQ92M1H393K	Mylar 0.039 μ F \pm 10%	
C23	CQ92M1H103K	Mylar 0.01 μ F \pm 10%	
C24	CQ92M1H223K	Mylar 0.022 μ F \pm 10%	
C25	CK45B1H471K	Ceramic 470pF \pm 10%	
C26	CQ92M1H103K	Mylar 0.01 μ F \pm 10%	
C27	CK45F1H103Z	Ceramic 0.01 μ F +80%, -20%	
C28	CC45CH1H330J	Ceramic 33pF \pm 5%	
C29	CC45CH1H070D	Ceramic 7pF \pm 0.5pF	
C30	CC45CH1H020C	Ceramic 2pF \pm 0.25pF	
C31	CK45F1H103Z	Ceramic 0.01 μ F +80%, -20%	
C32	CE04W1A101	Electrolytic 100 μ F 10WV	
C33	CK45B1H681K	Ceramic 680pF \pm 10%	
C34	CC45SL1H151K	Ceramic 150pF \pm 10%	
C35	CC45CH1H150J	Ceramic 15pF \pm 5%	
C36, 37	CK45F1H103Z	Ceramic 0.01 μ F +80%, -20%	
C38	CC45SL1H221K	Ceramic 220pF \pm 10%	
C39, 40	CK45B1H471K	Ceramic 470pF \pm 10%	
C41	CQ92M1H472K	Mylar 4700pF \pm 10%	
C42	CQ92M1H223K	Mylar 0.022 μ F \pm 10%	
C43, 44	CC45SL1H221K	Ceramic 220pF \pm 10%	
C45	CQ92M1H102K	Mylar 1000pF \pm 10%	
C46	CQ92M1H473K	Mylar 0.047 μ F \pm 10%	
C47	CQ92M1H223K	Mylar 0.022 μ F \pm 10%	
C48	CE04W1E4R7	Electrolytic 4.7 μ F 25WV	
C49, 50	CQ92M1H682K	Mylar 6800pF \pm 10%	
C51	CE04W1C100	Electrolytic 10 μ F 16WV	
C52	CQ92M1H393K	Mylar 0.039 μ F \pm 10%	
C53, 54	CE04W1C100	Electrolytic 10 μ F 16WV	
C55	CC45CH1H330J	Ceramic 33pF \pm 5%	
C56	CQ92M1H393K	Mylar 0.039 μ F \pm 10%	
C57	CE04W1E4R7	Electrolytic 4.7 μ F 25WV	
C58	CK45F1H103Z	Ceramic 0.01 μ F +80%, -20%	
C59	CE04W1E4R7	Electrolytic 4.7 μ F 25WV	
C60, 61	CE04W1H010	Electrolytic 1 μ F 50WV	
C62	CE04W1A470	Electrolytic 47 μ F 10WV	
C63	CE04W1C220	Electrolytic 22 μ F 16WV	
C64	CQ92M1H223K	Mylar 0.022 μ F \pm 10%	
C65	CQ92M1H682K	Mylar 6800pF \pm 10%	
C66, 67	CE04W1H010	Electrolytic 1 μ F 50WV	
C68	CE04W1A470	Electrolytic 47 μ F 10WV	
C69	CQ92M1H393K	Mylar 0.039 μ F \pm 10%	
C70	CE04W1C101	Electrolytic 100 μ F 16WV	
C71	CK45F1H103Z	Ceramic 0.01 μ F +80%, -20%	
C72	CE04W1C100	Electrolytic 10 μ F 16WV	
C73	CQ92M1H682K	Mylar 6800pF \pm 10%	
C74	CQ92M1H332K	Mylar 3300pF \pm 10%	
C75	CQ92M1H152K	Mylar 1500pF \pm 10%	
C76~78	CE04W1H010	Electrolytic 1 μ F 50WV	
C79	CE04W1HR47	Electrolytic 0.47 μ F 50WV	
C80, 81	CE04W1H010	Electrolytic 1 μ F 50WV	
C82	CE04W1HR47	Electrolytic 0.47 μ F 50WV	
C83, 84	CK45F1H103Z	Ceramic 0.01 μ F +80%, -20%	
C85	CC45SL1H101K	Ceramic 100pF \pm 10%	
C86~90	CQ92M1H682K	Mylar 6800pF \pm 10%	
C91	CE04W1H010	Electrolytic 1 μ F 50WV	
C92	CE04W1A470	Electrolytic 47 μ F 10WV	
C93	CK45F1H103Z	Ceramic 0.01 μ F +80%, -20%	
C94	CE04W1C100	Electrolytic 10 μ F 16WV	

PARTS LIST

Ref. No.	Parts No.	Description	Re- marks
C95	CE04W1A470	Electrolytic 47 μ F 10WV	
C96	CK45F1H103Z	Ceramic 0.01 μ F +80%, -20%	
C97	CE04W1HR47J	Electrolytic 0.47 μ F 50WV	
C98	CK45F1H103Z	Ceramic 0.01 μ F +80%, -20%	
C99	CE04W1C100	Electrolytic 10 μ F 16WV	
C100, 101	CE04W1H010	Electrolytic 1 μ F 50WV	
C102	CC45SL1H101K	Ceramic 100pF \pm 10%	

RESISTOR

R1, 2	RD14CY2E104J	Carbon 100k Ω \pm 5% 1/4W	
R3	RD14CY2E823J	Carbon 82k Ω \pm 5% 1/4W	
R4, 5	RD14CY2E101J	Carbon 100 Ω \pm 5% 1/4W	
R6	RD14BY2E151J	Carbon 150 Ω \pm 5% 1/4W	
R7, 8	RD14CY2E104J	Carbon 100k Ω \pm 5% 1/4W	
R9	RD14CY2E470J	Carbon 47 Ω \pm 5% 1/4W	
R10	RD14CY2E101J	Carbon 100 Ω \pm 5% 1/4W	
R11	RD14CY2E332J	Carbon 3.3k Ω \pm 5% 1/4W	
R12	RD14CY2E153J	Carbon 15k Ω \pm 5% 1/4W	
R13	RD14CY2E472J	Carbon 4.7k Ω \pm 5% 1/4W	
R14	RD14CY2E151J	Carbon 150 Ω \pm 5% 1/4W	
R15	RD14CY2E331J	Carbon 330 Ω \pm 5% 1/4W	
R16	RD14CY2E333J	Carbon 33k Ω \pm 5% 1/4W	
R17	RD14CY2E472J	Carbon 4.7k Ω \pm 5% 1/4W	
R18	RD14CY2E102J	Carbon 1k Ω \pm 5% 1/4W	
R19	RD14CY2E332J	Carbon 3.3k Ω \pm 5% 1/4W	
R20	RD14CY2E152J	Carbon 1.5k Ω \pm 5% 1/4W	
R21	RD14CY2E183J	Carbon 18k Ω \pm 5% 1/4W	
R22	RD14CY2E104J	Carbon 100k Ω \pm 5% 1/4W	
R23	RD14CY2E332J	Carbon 3.3k Ω \pm 5% 1/4W	
R24	RD14CY2E562J	Carbon 5.6k Ω \pm 5% 1/4W	
R25	RD14CY2E333J	Carbon 33k Ω \pm 5% 1/4W	
R26, 27	RD14CY2E561J	Carbon 560 Ω \pm 5% 1/4W	
R28	RD14CY2E681J	Carbon 680 Ω \pm 5% 1/4W	
R29	RD14CY2E274J	Carbon 270k Ω \pm 5% 1/4W	
R30	RD14CY2E102J	Carbon 1k Ω \pm 5% 1/4W	
R31	RD14CY2E153J	Carbon 15k Ω \pm 5% 1/4W	
R32	RD14CY2E562J	Carbon 5.6k Ω \pm 5% 1/4W	
R33	RD14CY2E102J	Carbon 1k Ω \pm 5% 1/4W	
R34	RD14CY2E222J	Carbon 2.2k Ω \pm 5% 1/4W	
R35	RD14CY2E472J	Carbon 4.7k Ω \pm 5% 1/4W	
R36	RD14CY2E104J	Carbon 100k Ω \pm 5% 1/4W	
R37	RD14CY2E471J	Carbon 470 Ω \pm 5% 1/4W	
R38	RD14CY2E332J	Carbon 3.3k Ω \pm 5% 1/4W	
R39	RD14CY2E103J	Carbon 10k Ω \pm 5% 1/4W	
R40	RD14CY2E472J	Carbon 4.7k Ω \pm 5% 1/4W	
R41	RD14CY2E471J	Carbon 470 Ω \pm 5% 1/4W	
R42	RD14CY2E561J	Carbon 560 Ω \pm 5% 1/4W	
R43, 44	RD14CY2E102J	Carbon 1k Ω \pm 5% 1/4W	
R45, 46	RD14CY2E472J	Carbon 4.7k Ω \pm 5% 1/4W	
R47	RD14CY2E153J	Carbon 15k Ω \pm 5% 1/4W	
R48	RD14CY2E101J	Carbon 100 Ω \pm 5% 1/4W	
R49	RD14CY2E472J	Carbon 4.7k Ω \pm 5% 1/4W	
R50	RD14CY2E563J	Carbon 56k Ω \pm 5% 1/4W	
R51	RD14CY2E104J	Carbon 100k Ω \pm 5% 1/4W	
R52	RD14CY2E563J	Carbon 56k Ω \pm 5% 1/4W	
R53	RD14CY2E154J	Carbon 150k Ω \pm 5% 1/4W	
R54	RD14CY2E223J	Carbon 22k Ω \pm 5% 1/4W	
R55	RD14CY2E183J	Carbon 18k Ω \pm 5% 1/4W	
R56	RD14CY2E562J	Carbon 5.6k Ω \pm 5% 1/4W	
R57	RD14CY2E223J	Carbon 22k Ω \pm 5% 1/4W	
R58	RD14CY2E222J	Carbon 2.2k Ω \pm 5% 1/4W	
R59	RD14CY2E470J	Carbon 47 Ω \pm 5% 1/4W	
R60, 61	RD14CY2E102J	Carbon 1k Ω \pm 5% 1/4W	
R62	RD14CY2E473J	Carbon 47k Ω \pm 5% 1/4W	
R63	RD14CY2E223J	Carbon 22k Ω \pm 5% 1/4W	
R64	RD14CY2E222J	Carbon 2.2k Ω \pm 5% 1/4W	
R65	RD14CY2E472J	Carbon 4.7k Ω \pm 5% 1/4W	
R66	RD14CY2E331J	Carbon 330 Ω \pm 5% 1/4W	
R67	RD14CY2E562J	Carbon 5.6k Ω \pm 5% 1/4W	
R68, 69	RD14CY2E223J	Carbon 22k Ω \pm 5% 1/4W	
R70	RD14CY2E101J	Carbon 100 Ω \pm 5% 1/4W	
R71	RD14CY2E470J	Carbon 47 Ω \pm 5% 1/4W	

Ref. No.	Parts No.	Description	Re- marks
R72	RD14CY2E101J	Carbon 100 Ω \pm 5% 1/4W	
R73	RD14CY2E102J	Carbon 1k Ω \pm 5% 1/4W	
R74	RD14CY2E101J	Carbon 100 Ω \pm 5% 1/4W	
R75	RD14CY2E102J	Carbon 1k Ω \pm 5% 1/4W	
R76, 77	RS14AB3A010J	Metal film 1 Ω \pm 5% 1W	
R78	RD14CY2E561J	Carbon 560 Ω \pm 5% 1/4W	
R79	RD14CY2E563J	Carbon 56k Ω \pm 5% 1/4W	
R80	RD14CY2E105J	Carbon 1M Ω \pm 5% 1/4W	
R81~83	RD14CY2E154J	Carbon 150k Ω \pm 5% 1/4W	
R84	RD14CY2E105J	Carbon 1M Ω \pm 5% 1/4W	
R85	RD14CY2E153J	Carbon 15k Ω \pm 5% 1/4W	
R86	RD14CY2E562J	Carbon 5.6k Ω \pm 5% 1/4W	
R87, 88	RD14CY2E103J	Carbon 10k Ω \pm 5% 1/4W	
R89	RD14CY2E473J	Carbon 47k Ω \pm 5% 1/4W	
R90	RD14CY2E223J	Carbon 22k Ω \pm 5% 1/4W	
R91	RD14CY2E473J	Carbon 47k Ω \pm 5% 1/4W	
R92, 93	RD14CY2E103J	Carbon 10k Ω \pm 5% 1/4W	
R94	RD14CY2E473J	Carbon 47k Ω \pm 5% 1/4W	
R95	RD14CY2E333J	Carbon 33k Ω \pm 5% 1/4W	
R96	RD14CY2E103J	Carbon 10k Ω \pm 5% 1/4W	
R97	RD14CY2E682J	Carbon 6.8k Ω \pm 5% 1/4W	
R98	RD14CY2E105J	Carbon 1M Ω \pm 5% 1/4W	
R99	RD14CY2E274J	Carbon 270k Ω \pm 5% 1/4W	
R100	RD14CY2E124J	Carbon 120k Ω \pm 5% 1/4W	
R101	RD14CY2E683J	Carbon 68k Ω \pm 5% 1/4W	
R102	RD14CY2E103J	Carbon 10k Ω \pm 5% 1/4W	
R103	RD14CY2E124J	Carbon 120k Ω \pm 5% 1/4W	
R104	RD14CY2E274J	Carbon 270k Ω \pm 5% 1/4W	
R105	RD14CY2E105J	Carbon 1M Ω \pm 5% 1/4W	
R106	RD14CY2E103J	Carbon 10k Ω \pm 5% 1/4W	
R107	RD14CY2E473J	Carbon 47k Ω \pm 5% 1/4W	
R108	RD14CY2E102J	Carbon 1k Ω \pm 5% 1/4W	
R109	RD14CY2E473J	Carbon 47k Ω \pm 5% 1/4W	
R110	RD14CY2E471J	Carbon 470 Ω \pm 5% 1/4W	
R111	RC05GF2H5R6J	Carbon 5.6 Ω \pm 5% 1/2W	
R112	RD14CY2E103J	Carbon 10k Ω \pm 5% 1/4W	
R113	RD14CY2E332J	Carbon 3.3k Ω \pm 5% 1/4W	
R114, 115	RD14CY2E472J	Carbon 4.7k Ω \pm 5% 1/4W	
R116	RD14CY2E561J	Carbon 560 Ω \pm 5% 1/4W	
R117	RD14CY2E333J	Carbon 33k Ω \pm 5% 1/4W	
R118	RD14CY2E472J	Carbon 4.7k Ω \pm 5% 1/4W	
R119	RD14CY2E473J	Carbon 47k Ω \pm 5% 1/4W	
R120	RD14CY2E153J	Carbon 15k Ω \pm 5% 1/4W	

POTENTIOMETER

VR1	R12-4016-05	Semi-fixed resistor 50k Ω	
VR2, 3	R12-3025-05	Semi-fixed resistor 10k Ω	

SEMICONDUCTOR

Q1	V09-0081-05	FET 3SK40 (L) or 3SK41 (L)	
Q2	V09-0057-05	FET 3SK41 (L, M)	
Q3, 4	V03-0079-05	Transistor 2SC460 (B)	
Q5, 6	V03-0299-05	Transistor 2SC1000 (GR)	
Q7~10	V03-0079-05	Transistor 2SC460 (B)	
Q11	V30-0143-05	Hi-bread IC H8D5022	*
Q12	V30-0138-05	IC TA7120P	
Q13, 14	V03-0093-05	Transistor 2SC458 (B)	
Q15	V03-0299-05	Transistor 2SC1000 (GR)	
Q16	V03-0126-05	Transistor 2SC734 (Y)	
Q17, 18	V04-0046-05	Transistor 2SD235 (Y)	
Q19, 20	V03-0093-05	Transistor 2SC458 (B)	
Q21	V01-0037-05	Transistor 2SA495 (Y, O)	
Q22, 23	V03-0093-05	Transistor 2SC458 (B)	
Q24, 25	V03-0299-05	Transistor 2SC1000 (GR)	
Q26	V03-0093-05	Transistor 2SC458 (B)	
Q27, 28	V03-0336-05	Transistor 2SC496 (Y, O)	
Q29	V03-0093-05	Transistor 2SC458 (B)	
Q30	V03-0270-05	Transistor 2SC945 (QR)	
D1, 2	V11-0051-05	Diode 1N60	
D3~6	V11-0076-05	Diode 1S1555	

PARTS LIST

Ref. No.	Parts No.	Description	Re- marks
D7~10	V11-0051-05	Diode 1N60	
D11	V11-0076-05	Diode 1S1555	
D12, 13	V11-0051-05	Diode 1N60	
D14, 15	V11-0076-05	Diode 1S1555	
D16	V11-0240-05	Zener diode WZ-090	
D17	V11-0051-05	Diode 1N60	
COIL			
L1	L31-0267-05	ANT coil	
L2	L79-0402-05	Helical block	☆
L3	L30-0005-05	IFT	
L4	L71-0201-05	Monolithic filter	☆
L5	L30-0289-05	IFT	
L6	L72-0014-05	Ceramic filter	
L7	L72-0037-05	Ceramic filter	
L8	L30-0199-05	IFT	
L9	L31-0180-05	Tuning coil	
L10	L40-1021-03	Ferri-inductor	
L11	L77-0327-05	Crystal oscillator 10.245MHz	
L12	L40-1021-03	Ferri-inductor	
L13	L30-0285-05	Discr coil (D)	
L14	L30-0286-05	Discr coil (E)	
L15, 16	L40-2225-04	Ferri-inductor	
L17	L12-0013-05	Input transformer	
MISCELLANEOUS			
—	E23 0047-04	Terminal x 31	
—	E40-0611-05	Mini connector wafer	
—	F01-0150-14	Heat sink	
—	F07-0313-14	Shield cover	
—	F20-0078-05	Insulation plate x 2	
—	F29-0014-05	Insulation washer x 2	

TX UNIT (X56-1230-10)

Ref. No.	Parts No.	Description	Re- marks
CAPACITOR			
C2	CE04W1C100	Electrolytic 10 μ F 16WV	
C3	CE04W1A470	Electrolytic 47 μ F 10WV	
C4	CS15E1V0R1M	Tantalum 0.1 μ F 35WV	
C5	CK45F1H103Z	Ceramic 0.01 μ F +80%, -20%	
C6	CE04W1E4R7	Electrolytic 4.7 μ F 25WV	
C7	CE04W1A470	Electrolytic 47 μ F 10WV	
C8	CC45CH1H050D	Ceramic 5pF \pm 0.5pF	
C9	CE04W1H010	Electrolytic 1 μ F 50WV	
C10	CQ92M1H103K	Mylar 0.01 μ F \pm 10%	
C11	CQ92M1H393K	Mylar 0.039 μ F \pm 10%	
C12	CQ92M1H473K	Mylar 0.047 μ F \pm 10%	
C13	CC45CH1H330J	Ceramic 33pF \pm 5%	
C14	CC45UJ1H050D	Ceramic 5pF \pm 0.5pF	
C15, 16	CC45SL1H221K	Ceramic 220pF \pm 10%	
C17	CC45CH1H220J	Ceramic 22pF \pm 5%	
C18~22	CK45F1H103Z	Ceramic 0.01 μ F +80%, -20%	
C23	CC45CH1H330J	Ceramic 33pF \pm 5%	
C24, 25	CK45D1H102M	Ceramic 1000pF \pm 20%	
C26	CC45TH1H220J	Ceramic 22pF \pm 5%	
C27, 28	CC45CH1H330J	Ceramic 33pF \pm 5%	
C29, 30	CK45F1H103Z	Ceramic 0.01 μ F +80%, -20%	
C31	CK45TH1H220J	Ceramic 22pF \pm 5%	
C32	CC45CH1H050D	Ceramic 5pF \pm 0.5pF	
C33	CC45SL1H0R5C	Ceramic 0.5pF \pm 0.25pF	
C34, 35	CC45TH1H150J	Ceramic 15pF \pm 5%	
C36	CC45SL1H0R5C	Ceramic 0.5pF \pm 0.25pF	
C37	CC45TH1H150J	Ceramic 15pF \pm 5%	
C38	CC45CH1H470J	Ceramic 47pF \pm 5%	
C39, 40	CK45F1H103Z	Ceramic 0.01 μ F +80%, -20%	
C41, 42	CE04W1A470	Electrolytic 47 μ F 10WV	

Ref. No.	Parts No.	Description	Re- marks
C43	CS15E1V0R1M	Tantalum 0.1 μ F 35WV	
C44	CE04W1C100	Electrolytic 10 μ F 16WV	
C45	CE04W1A470	Electrolytic 47 μ F 10WV	
C46	CQ92M1H102K	Mylar 1000pF \pm 10%	
C47	CE04W1H010	Electrolytic 1 μ F 50WV	
C48, 49	CK45F1H103Z	Ceramic 0.01 μ F +80%, -20%	
C50	CE04W1C100	Electrolytic 10 μ F 16WV	
C51	CK45F1H103Z	Ceramic 0.01 μ F +80%, -20%	
C52	CE04W1HR47	Electrolytic 0.47 μ F 50WV	
C53	CK45F1H103Z	Ceramic 0.01 μ F +80%, -20%	
C54	CC45UJ1H220J	Ceramic 22pF \pm 5%	
C55	CK45F1H103Z	Ceramic 0.01 μ F +80%, -20%	
C56	CE04W1A470	Electrolytic 47 μ F 10WV	
C57	CK45F1H103Z	Ceramic 0.01 μ F +80%, -20%	
C58~60	CK45D1H102M	Ceramic 1000pF \pm 20%	
C61	CC45CH1H100D	Ceramic 10pF \pm 0.5pF	
C62, 63	CK45F1H103Z	Ceramic 0.01 μ F +80%, -20%	
C64	CK45D1H102M	Ceramic 1000pF \pm 20%	
C65	CC45SL2H100D	Ceramic 10pF \pm 0.5pF	
C66	CK45D1H102M	Ceramic 1000pF \pm 20%	
C67	CK45F1H103Z	Ceramic 0.01 μ F +80%, -20%	
C68	CC45SL2H050D	Ceramic 5pF \pm 0.5pF	

RESISTOR

R1	RD14CY2E101J	Carbon 100 Ω \pm 5% 1/4W	
R2	RD14CY2E561J	Carbon 560 Ω \pm 5% 1/4W	
R3	RD14CY2E102J	Carbon 1k Ω \pm 5% 1/4W	
R5	RD14CY2B333J	Carbon 33k Ω \pm 5% 1/8W	
R6	RD14BY2E333J	Carbon 33k Ω \pm 5% 1/4W	
R7	RD14CY2E473J	Carbon 47k Ω \pm 5% 1/4W	
R8	RD14CY2E223J	Carbon 22k Ω \pm 5% 1/4W	
R9	RD14CY2E102J	Carbon 1k Ω \pm 5% 1/4W	
R10	RD14CY2E472J	Carbon 4.7k Ω \pm 5% 1/4W	
R11	RD14CY2E153J	Carbon 15k Ω \pm 5% 1/4W	
R12	RD14CY2E102J	Carbon 1k Ω \pm 5% 1/4W	
R13	RD14CY2E221J	Carbon 220 Ω \pm 5% 1/4W	
R14, 15	RD14CY2E103J	Carbon 10k Ω \pm 5% 1/4W	
R16	RD14CY2E102J	Carbon 1k Ω \pm 5% 1/4W	
R17	RD14CY2E101J	Carbon 100 Ω \pm 5% 1/4W	
R18~21	RD14CY2E473J	Carbon 47k Ω \pm 5% 1/4W	
R22	RD14CY2E103J	Carbon 10k Ω \pm 5% 1/4W	
R23	RD14CY2E333J	Carbon 33k Ω \pm 5% 1/4W	
R24	RD14CY2E103J	Carbon 10k Ω \pm 5% 1/4W	
R25	RD14CY2E563J	Carbon 56k Ω \pm 5% 1/4W	
R26	RD14CY2E103J	Carbon 10k Ω \pm 5% 1/4W	
R27	RD14CY2E473J	Carbon 47k Ω \pm 5% 1/4W	
R28	RD14CY2E682J	Carbon 6.8k Ω \pm 5% 1/4W	
R29	RD14CY2E333J	Carbon 33k Ω \pm 5% 1/4W	
R30, 31	RD14CY2E472J	Carbon 4.7k Ω \pm 5% 1/4W	
R32	RD14CY2E102J	Carbon 1k Ω \pm 5% 1/4W	
R33	RD14CY2E473J	Carbon 47k Ω \pm 5% 1/4W	
R34	RD14CY2E332J	Carbon 3.3k Ω \pm 5% 1/4W	
R35	RD14CY2E222J	Carbon 2.2k Ω \pm 5% 1/4W	
R36	RD14CY2E154J	Carbon 150k Ω \pm 5% 1/4W	
R37	RD14CY2E104J	Carbon 100k Ω \pm 5% 1/4W	
R38	RD14CY2E103J	Carbon 10k Ω \pm 5% 1/4W	
R39	RD14CY2E681J	Carbon 680 Ω \pm 5% 1/4W	
R40	RD14CY2E471J	Carbon 470 Ω \pm 5% 1/4W	
R41	RC05GF2H5R6J	Carbon 5.6 Ω \pm 5% 1/2W	
R42	RD14CY2E561J	Carbon 560 Ω \pm 5% 1/4W	
R43	RD14CY2E471J	Carbon 470 Ω \pm 5% 1/4W	
R44	RD14CY2E682J	Carbon 6.8k Ω \pm 5% 1/4W	
R45	RD14CY2E471J	Carbon 470 Ω \pm 5% 1/4W	
R46	RD14CY2E561J	Carbon 560 Ω \pm 5% 1/4W	
R47	RD14CY2E681J	Carbon 680 Ω \pm 5% 1/4W	
R48, 49	RD14CY2E103J	Carbon 10k Ω \pm 5% 1/4W	
R50	RD14CY2E153J	Carbon 15k Ω \pm 5% 1/4W	
R51	RD14CY2E100J	Carbon 10 Ω \pm 5% 1/4W	
R52	RD14CY2E470J	Carbon 47 Ω \pm 5% 1/4W	
R53	RD14BY2E102J	Carbon 1k Ω \pm 5% 1/4W	

PARTS LIST/PACKING

Ref. No.	Parts No.	Description	Re- marks
R54	RD14BY2E101J	Carbon 100Ω ±5% 1/4W	
POTENTIOMETER			
VR1, 2	R12-2015-05	Semi-fixed resistor 5kΩ	
VR3	R12-0042-05	Semi-fixed resistor 500Ω	
VR4	R12-4016-05	Semi-fixed resistor 50kΩ	
VR5	R12-0042-05	Semi-fixed resistor 500Ω	
TC1	C05-0030-15	Ceramic trimmer 20pF	
TC2~4	C05-0013-15	Ceramic trimmer 20pF	
SEMICONDUCTOR			
Q1	V30-0039-05	IC TA7061AP	
Q2, 3	V03-0079-05	Transistor 2SC460 (B)	
Q4, 5	V09-0012-05	FET 2SK19 (GR)	
Q6~8	V03-0093-05	Transistor 2SC458 (B)	
Q9	V03-0336-05	Transistor 2SC496 (Y, O)	
Q10	V01-0113-05	Transistor 2SA496 (Y, O)	
Q11, 12	V03-0126-05	Transistor 2SC734 (Y, O)	
Q13	V09-0057-05	FET 3SK41 (L, M)	
Q14	V03-0283-05	Transistor 2SC741	
Q15	V03-0489-05	Transistor 2SC908	☆
D1~5	V11-0273-05	Diode 1S2208	
D2~5	V11-7761-86	Diode 1TT410	☆
D6, 7	V11-0076-05	Diode 1S1555	
D8	V11-0247-05	Zener diode WZ-100	
D9	V11-0076-05	Diode 1S1555	
D10	V11-0243-05	Zener diode WZ-061	
D11, 12	V11-0076-05	Diode 1S1555	
COIL			
L1	L40-1545-06	Ferri-inductor	
L2	L33-0264-05	Choke coil 30μH	
L3	L39-0069-05	Variable inductor 15μH	
L4	L33-0236-05	Choke coil 10μH	
L5	L77-0710-05	Crystal oscillator 10.715 MHz	
L6	L40-1021-03	Ferri-inductor	
L7	L30-0005-05	IFT	
L8	L31-0313-05	Tuning coil	
L9, 10	L40-1001-03	Ferri-inductor	
L11	L31-0344-05	Tuning coil	
L12	L31-0180-05	Tuning coil	
L13, 14	L31-0267-05	Tuning coil	
L15	L34-0388-05	VHF coil 6φ 5T	
L16	L40-1021-03	Ferri-inductor	
L17	L34-0606-05	VHF coil 6φ 6T	☆
L18	L34-0387-05	VHF coil 6φ 4T	
L19	L34-0499-05	VHF coil 3μ 4T	
L20	L34-0387-05	VHF coil 6φ 4T	
L21	L33-0235-05	Choke coil (with 100Ω)	
L22	L34-0452-05	VHF coil 3φ 6T	
MISCELLANEOUS			
J1	E18-0307-15	Monofolk socket	
-	E23-0046-04	Terminal	
-	E23-0047-04	Terminal x 26	
-	F02-0030-05	Heat sink (for Q14)	
-	F02-0401-05	Heat sink (for Q15)	☆

ACCESSORIES SUPPLIED

- Dynamic microphone equipped with 4-pin plug (T91-0302-05) 1 piece
- Mounting bracket (J21-0941-02) 1 piece
- Mounting parts
Screws, 6mm diameter (N09-0008-04) 4 pieces
Plain washers, 6mm diameter (N15-1060-46) 4 pieces
Spring washers, 6mm diameter (N16-0060-41) 4 pieces
Nuts, 6mm diameter (N14-0009-04) 4 pieces
- Stand-off bracket (J01-0021-04) 1 piece
- Label 1 sheet
- Spare fuse, 10A (F05-1031-05) 1 piece
- DC power cord with plug and fuse 1 piece
- Miniature plug for external speaker and touch tone pad (E12-0001-05) 2 pieces
- Plug-equipped PC board for tone squelch 1 sheet
- Operating manual (B50-2515-00) 1 copy

PACKING

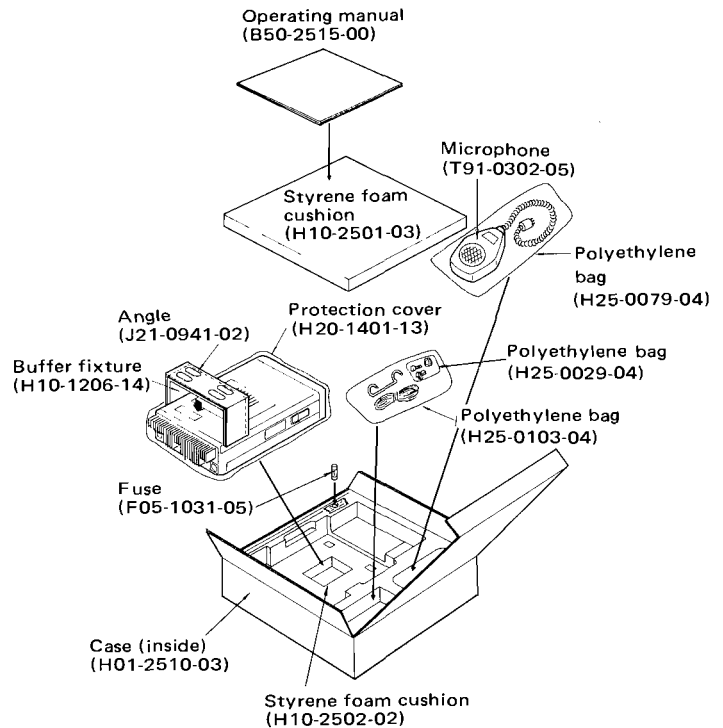

DISASSEMBLY

REMOVING THE CASE (Refer to Fig. 6)

1. Remove the screws ① ~ ⑩.
2. Remove the upper and lower cases.

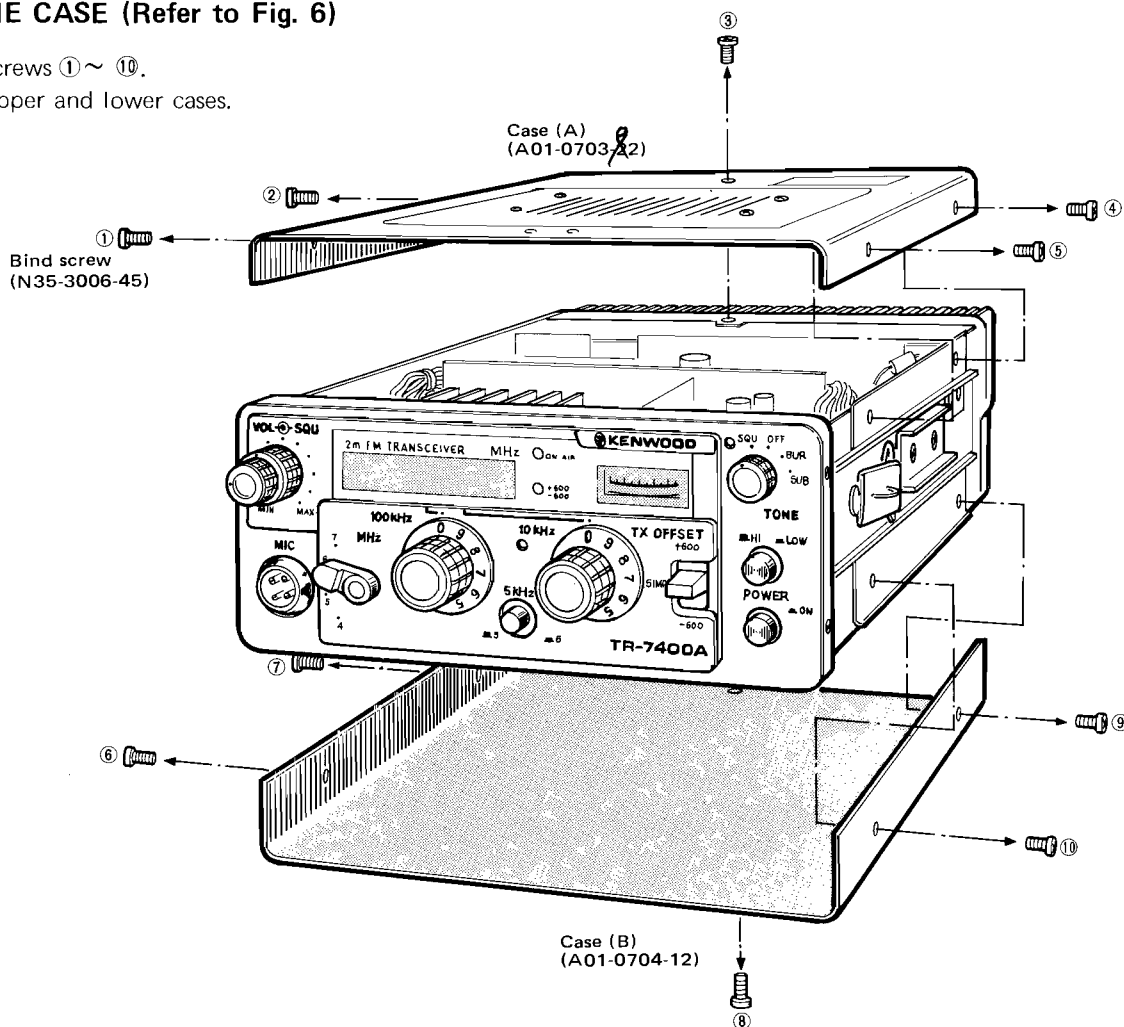

Fig. 6 Removing the Case

REMOVING THE PANEL (Refer to Fig. 7)

1. Remove the knobs.
2. Remove the screws A ~ D.
3. Remove the panel and the subpanel.

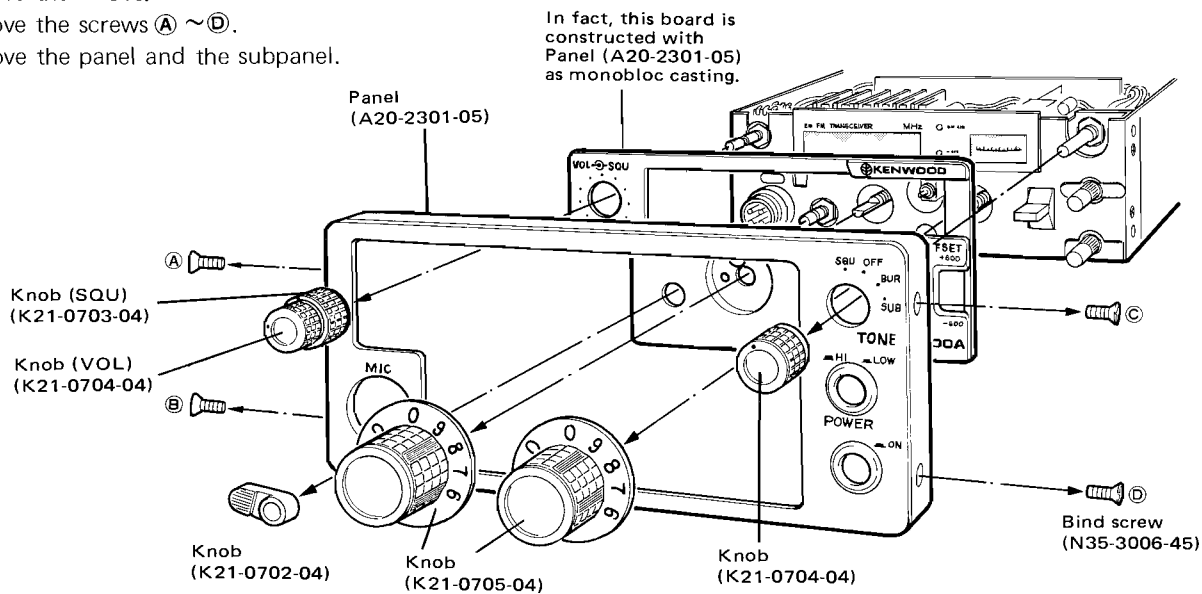

Fig. 7 Removing the Panel

DISASSEMBLY

REMOVING THE INDICATOR (Refer to Fig. 8)

1. Remove the cases.
2. Remove the panel.
3. Remove the screws ①, ② and remove the front glass.
4. Pull out the necessary part of the indicator upward.

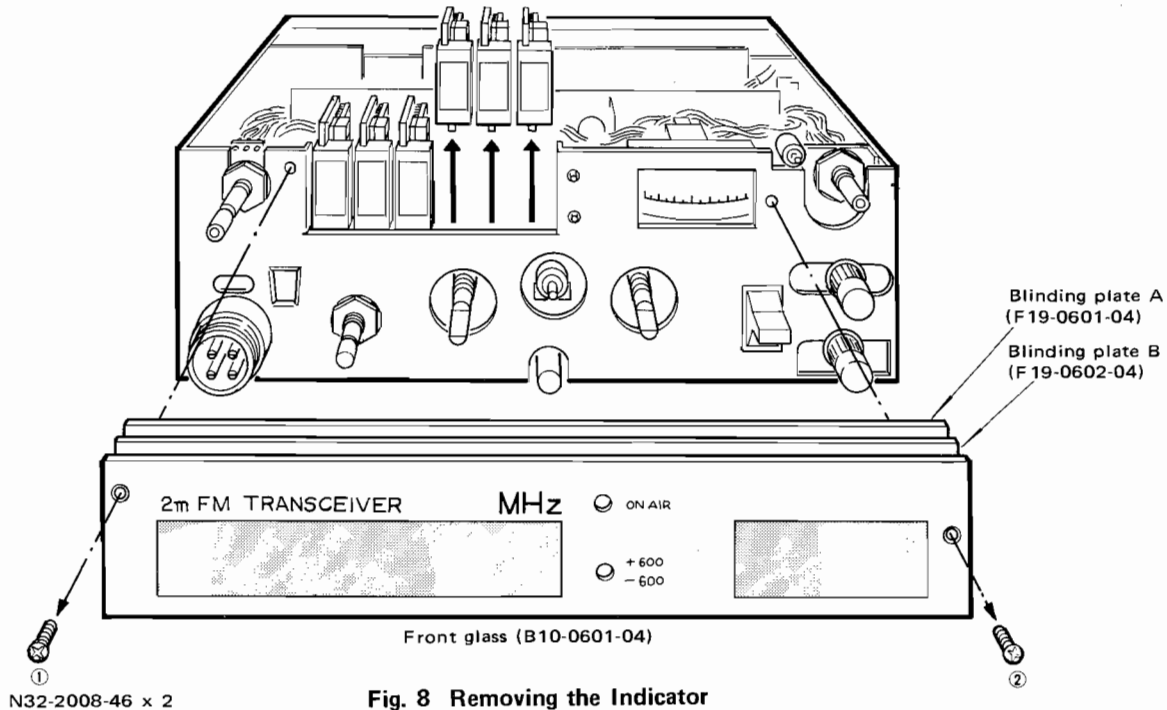

Fig. 8 Removing the Indicator

REMOVING THE FINAL SECTION (Refer to Fig. 9)

1. Remove the leads (A) and (B) from the terminal pins.
2. Remove the screws ①~④.
3. Pull Final section out.

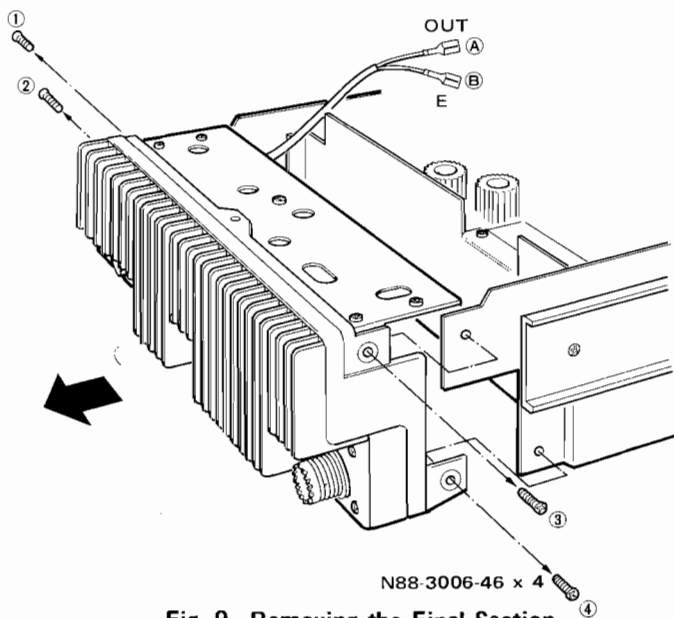

Fig. 9 Removing the Final Section

REMOVING THE TX UNIT (Refer to Fig. 10)

1. Remove the leads (A) and (B) from terminal pins.
2. Remove the screws ①~⑤.
3. Lift TX unit up in the direction of arrow.

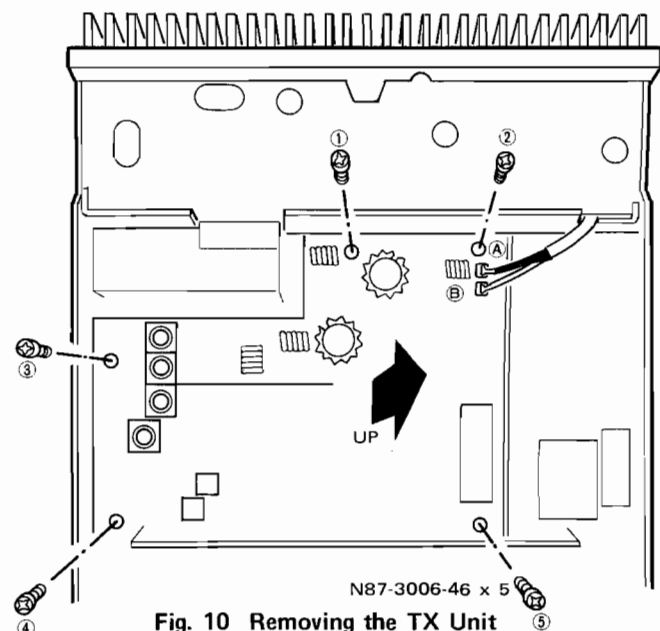

Fig. 10 Removing the TX Unit

DISASSEMBLY

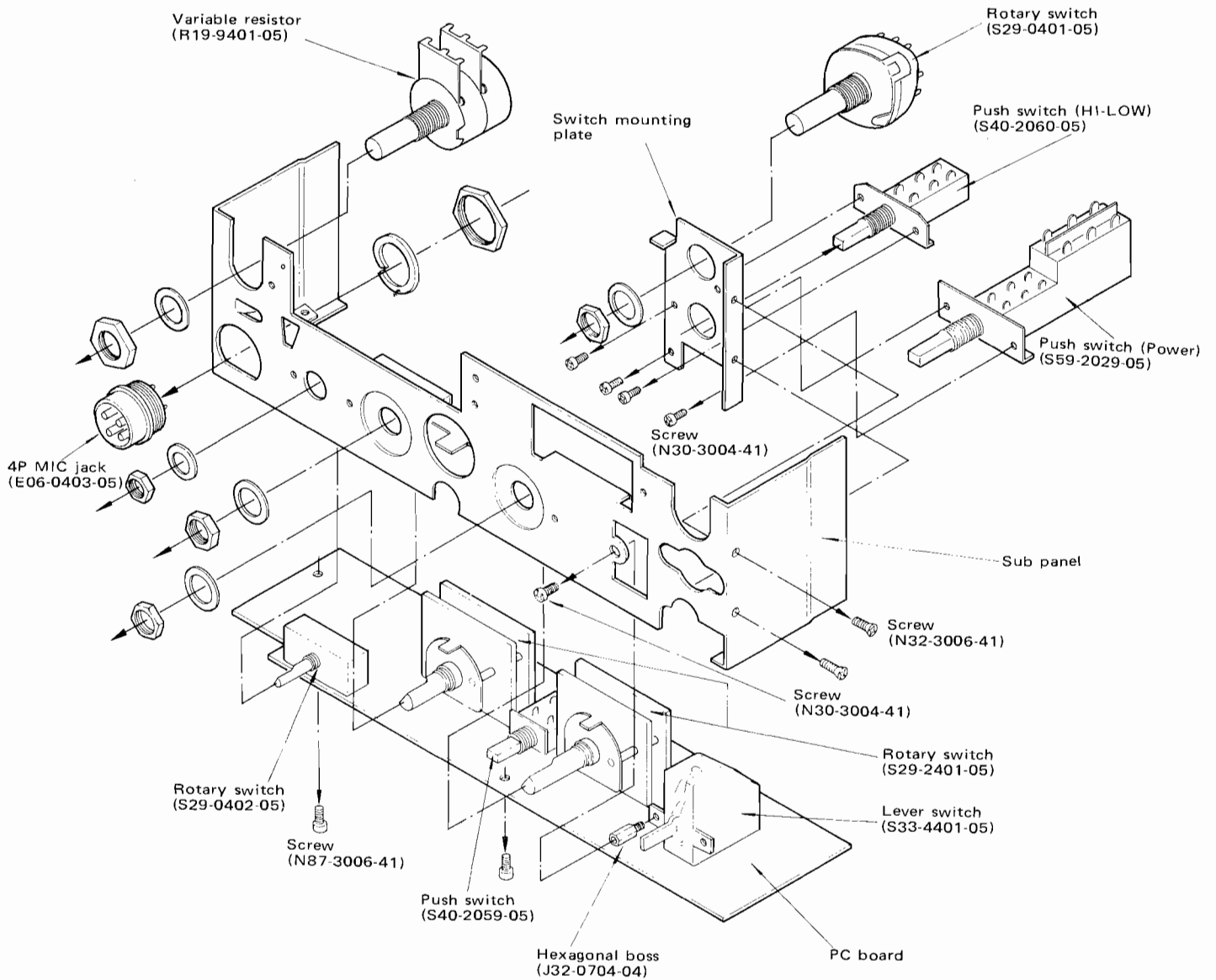

Fig. 11 Disassembling the Sub Panel

TO REMOVING LED MOTHER BOARD

1. Remove knobs and front panel.
2. Loosen SQ/VOL control knob.
3. Remove all LED display.
4. Remove 4 screws on each corner of mother board J25-2513-03.
5. Remove 2 connectors on board.
6. Gently push to rear and lift up.

TROUBLESHOOTING

Troubleshooting (PLL)

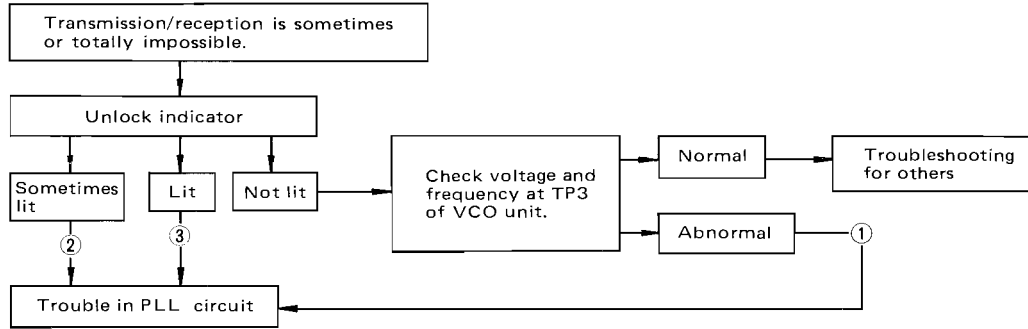

Condition	Service Point	Possible Cause	Measures (Remedy)
①	1) 5V supply at AVR circuit (main body) 2) VCO amplifier	<ul style="list-style-type: none"> · No 5V supply due to malfunction in IC101 and Q101. · Q12 and L15 broken 	<ul style="list-style-type: none"> · Check voltage and replace transformer. · Check voltage and replace transformer coil.
②	1) VCO unit 2) PD unit.	<ul style="list-style-type: none"> · Poor contact in wiring, parts, etc. · Poor contact in wiring, parts, etc. · Poor contact in wiring, parts, etc. · L1 crystal broken. 	<ul style="list-style-type: none"> · Check voltages, etc. · Check voltages and replace L16, 17 crystal. · Check voltages. · Check voltages and replace L1 crystal.
③	VCO unit 1) Voltage at 9V terminal. 2) RF voltage at TP2.	<ul style="list-style-type: none"> · Q10, 11 broken. · Q18, O2, 3 or crystal broken. 	<ul style="list-style-type: none"> · Check voltages. · Check voltages and replace defective parts. · Adjust it. · Adjust it.
	PD unit 1) Waveform and frequency at TP1. 2) Output from 12-pin of IC3. 3) Put a 135.3MHz signal of SSG into TP1 of VDO unit.	<ul style="list-style-type: none"> · Crystal or IC1 broken. · IC2, 3 broken. · IC4 (MC4044P) or IC5 ~ 12 broken. 	<ul style="list-style-type: none"> · Check waveform and frequency, and replace defective parts. · Check waveform and frequency, and replace defective parts. · Check waveform and frequency, and replace defective parts. · Check waveform at each part.

Malfunction in Transmitter

Symptom	Cause	Remedy
(1) No power output.	A: When current drain is more than 2A during transmission. <ul style="list-style-type: none"> ● Q1, Q2, D2, or D3 defective in PA unit. ● Insufficient continuity in antenna line. B: When current drain is about 1.2A during transmission. <ul style="list-style-type: none"> ● Coaxial cable defective between PA unit and TX unit (in particular, connecting part.) ● Q1 defective in PA unit. ● TX unit malfunction. 	Replacement Check Check Replacement Replacement

TROUBLESHOOTING

Symptom	Cause	Remedy
(2) Low power.	<ul style="list-style-type: none"> ● Improper adjustment in protection circuit. ● TR defective in final driver stage. ● Abnormal voltage in AVR (2SD235). ● Improper adjustment for trimmer in pre-driver stage. 	Readjustment Replacement Check Readjustment
(3) Defective deflection at RF meter (under normal power supply).	<ul style="list-style-type: none"> ● Antenna SWR defective. ● Improper adjustment for VR1 in PA unit. 	Check Readjustment
(4) Excessive power range.	A: When TX unit is normal. <ul style="list-style-type: none"> ● Improper adjustment for TC1 ~ TC4 in PA unit. B: When TX unit has a band. <ul style="list-style-type: none"> ● Improper adjustment for TC1 ~ TC4 in TX unit. ● Improper adjustment for VR61 ~ VR63 in main-body choke printed circuit board. 	Readjustment Readjustment Readjustment
(5) Hi-Low switchover malfunction.	<ul style="list-style-type: none"> ● Poor contact in Hi-Low switch. ● Improper adjustment for VR5 in TX unit. ● Q12 defective in TX unit. 	Replacement Readjustment Replacement
(6) Consumption current deviating from 4A (approx.) at 144 MHz without antenna connection.	<ul style="list-style-type: none"> ● Q4 defective in PA unit. ● Improper adjustment for VR3 in PA unit. ● Defective in TX unit. 	Replacement Readjustment Readjustment
(7) Large spurious.	A: For near-by spurious. <ul style="list-style-type: none"> ● Improper adjustment for L7, L8 in TX unit. ● Improper adjustment for L11 ~ L14 and VR3 in TX unit. ● Improper adjustment for VR61 ~ VR63 in main-body choke printed circuit board. B: For harmonics spurious. <ul style="list-style-type: none"> ● Improper adjustment for TC1 ~ TC4 in PA unit. 	Readjustment Readjustment Readjustment Readjustment
(8) Transmit/receive change-over malfunction	<ul style="list-style-type: none"> ● Microswitch broken. ● Poor contact at MIC terminal ● Relay defective (RL101). 	Replacement Check Replacement
(9) Modulation impossible.	<ul style="list-style-type: none"> ● MIC element defective. ● Poor contact at MIC terminal. ● SW of main body and Q71 of printed circuit board defective. ● Q1 defective in TX unit. ● Improper adjustment for VR1, VR5 in TX unit (in the case of insufficient modulation). 	Replacement Check Replacement Replacement Readjustment
(10) Tone squelch malfunction (in TX setting)	<ul style="list-style-type: none"> ● Improper insertion of printed circuit board of active filter in RX unit ● Active filter defective. ● Q11 defective in RX unit. <p style="margin-left: 20px;">Note: If modulation degree is improper, adjust it with VR31 of RF unit.</p>	Check Replacement Replacement
(11) Tone burst malfunction.	<ul style="list-style-type: none"> ● Q6 ~ Q8 defective in TX unit or piezo tuning fork broken. ● Improper adjustment for VR4 or trouble in C41, D6 in the case of abnormal time constant. 	Replacement Readjustment or replacement

TROUBLESHOOTING

Malfunction in Receiver

Symptom	Cause	Remedy
(1) No noise.	<ul style="list-style-type: none"> ● Squelch in ON setting. ● Tone switch set to tone squelch position. ● Malfunction in audio circuit. ● Speaker lead wires defective. (in particular, connecting parts). ● Ear phone jack broken. 	Set squelch to OFF. Set it to OFF. Check voltages. Check Check
(2) Low sensitivity	<ul style="list-style-type: none"> ● Antenna system defective (M-type connector, antenna wires, etc.) ● RF cavity tuning shifted. ● D6 defective in VCO unit. ● Improper adjustment for L9 in RX unit. 	Check Readjustment Replacement Readjustment
(3) Defective deflection at S meter.	<ul style="list-style-type: none"> ● Meter defective. ● Improper adjustment for VR1 for meter sensitivity adjustment. 	Replacement Readjustment
(4) Noise generated, but reception impossible.	<ul style="list-style-type: none"> ● 10.245 MHz (L11) crystal defective. ● Each TR defective in receiver (RF and IF stages). ● Improper adjustment for each coil in receiver (RF and IF stages). 	Replacement Replacement Readjustment
(5) Squelch malfunction.	<ul style="list-style-type: none"> ● Tone squelch set to ON position. ● Noise amplifier malfunction or Q12, Q13 defective in RX unit. ● Improper adjustment for VR2 in RX unit. 	Set it to OFF. Replacement Readjustment
(6) Zzz... noise generated with squelch switched ON and in the mode of TX → RX.	<ul style="list-style-type: none"> ● D15 defective in RX unit. 	Replacement
(7) Tone squelch malfunction (in RX setting).	<ul style="list-style-type: none"> ● Improper insertion of printed circuit board of active filter in RX unit. ● Q11, Q19 ~ 21, or D11 ~ D14 defective in RX unit. 	Check Replacement
(8) Howling caused near AF VR MAX.	<ul style="list-style-type: none"> ● Insufficient tightening of bolts for case, printed circuit boards, speaker, etc. ● C16 coming too close to C22 in VCO unit. 	Check Separate them.
(9) Howling near AF VR MAX.	<ul style="list-style-type: none"> ● VCO coil is loose on coil form. 	Reseal with glue.

Malfunction in Others

Symptom	Cause	Remedy
(1) F display LED not lit or letter trouble.	<ul style="list-style-type: none"> ● No 5V AVR output. ● LED defective. ● Driving IC (IC1 ~ IC3) defective. ● Rotary switch for F in trouble. ● Poor contact around sockets in display and LED printed circuit boards. ● Poor contact between pin and connector with lead wire of display printed circuit board. 	Check Replacement Replacement Check Check Check
(2) No power supply.	<ul style="list-style-type: none"> ● No fuse in fuse holder. ● Disconnection or improper soldering in power cable. ● Power switch broken. 	Provide fuses. Check Replacement
(3) Fuses blowing out.	<ul style="list-style-type: none"> ● Power circuit connected reversely. 	Check.

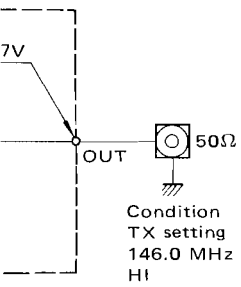
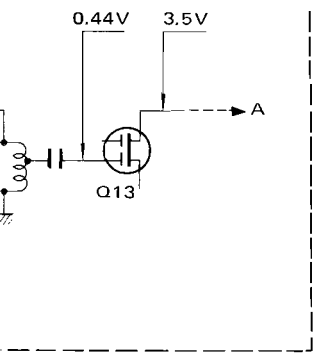

RECEIVER SECTION

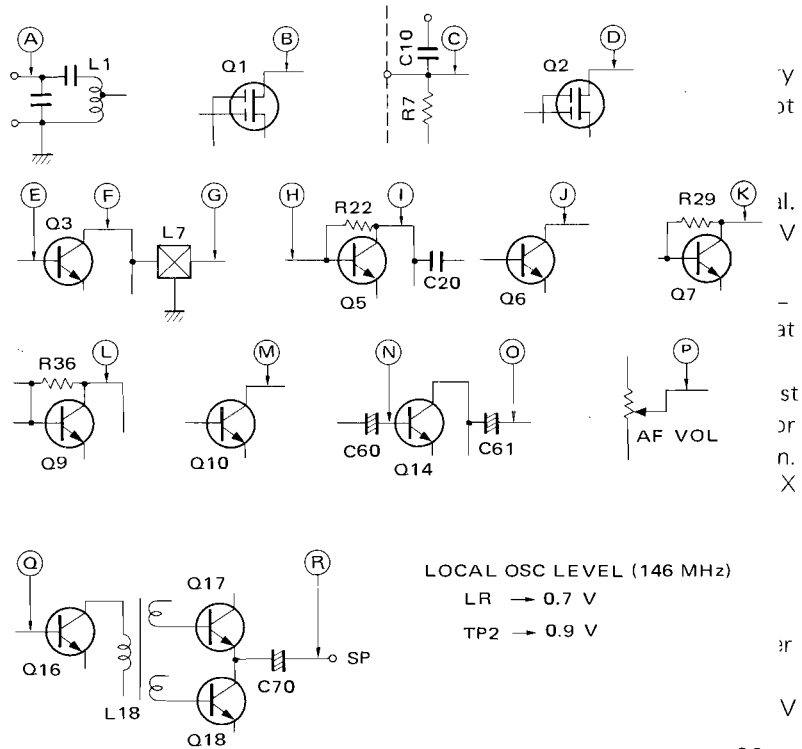
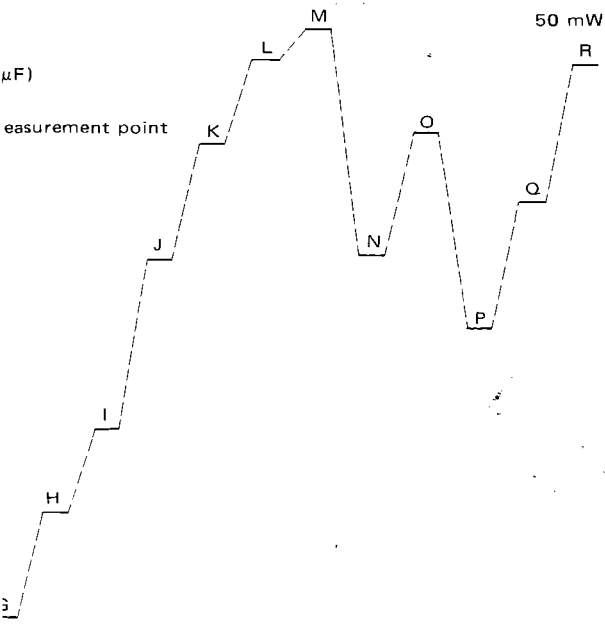
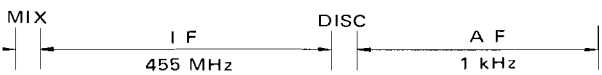

LOCAL OSC LEVEL (146 MHz)
 LR → 0.7 V
 TP2 → 0.9 V

ADJUSTMENT (PARTS ALIGNMENT)

TF

AC
2 n

P10

PA UNIT (X45-1090-10)



RX UNIT (X55-1150-10)

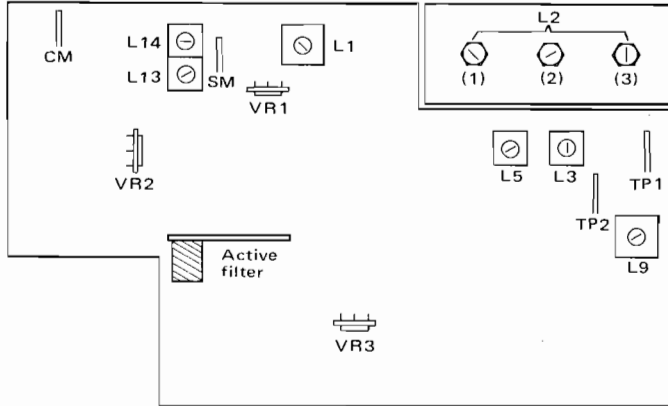

VCO UNIT
(X50-1370-10)



PA UNIT (X45-1090-10)

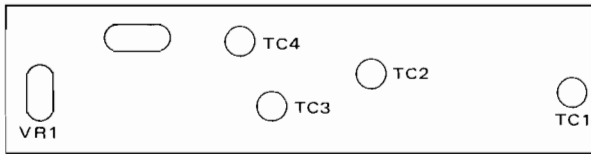

TX UNIT
(X56-1230-10)

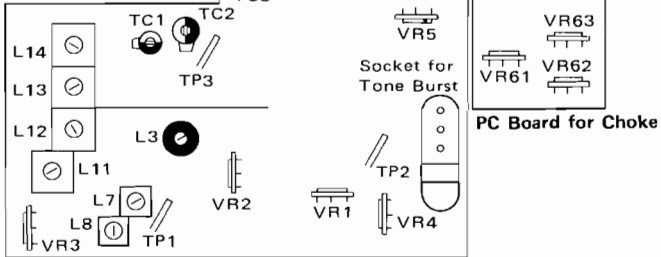

PD UNIT (X50-1380-10)

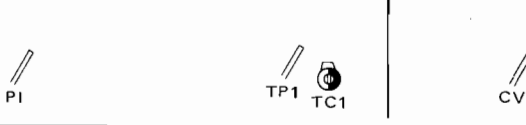

INDICATION UNIT
(X54-1210-10)

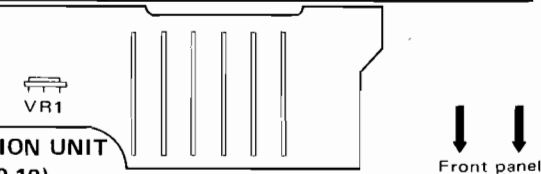

ADJUSTMENTS

TEST EQUIPMENT REQUIRED

1. Frequency Counter

Frequency range: Up to 150 MHz or more

2. SSG (Standard Signal Generator)

Capable of generating frequencies centering on 145 MHz, variable in amplitude, and also of frequency modulation.

Output voltage: -10 dB~100 dB
 AM: 30% modulation at 1 kHz
 FM: 7.5 kHz (1 kHz)

3. Oscilloscope

High-sensitivity oscilloscope, with external synch.

4. AF Vacuum-Tube Voltmeter

Frequency range: 50 Hz~10 kHz
 Input resistance: 1 megohm minimum
 Voltage range: F.S. = 3 mV up to 30 volts

5. RF Vacuum-Tube Voltmeter

Frequency range: 150 MHz or more

6. Vacuum-Tube Voltmeter

Input impedance: 10 megohms or more
 Voltage range: F.S. = 0.1 up to 1000 volts, AC and DC.

7. Power Meter

Power range: F.S. = 50W, 20W, 3W at 150 MHz or more

Input impedance of the meter should be 50 ohms.

8. Linear Detector

Frequency range: 150 MHz or more
 Frequency deviations: 10 kHz or more

The detector need not be used where high accuracy of measurement is not required.

9. AG (Audio Generator)

Output: 300 Hz~5 kHz
 Output voltage: 0.5 mV~1 V

10. AF Dummy Load

8 ohms and 3 watts approximately.

11. DC Regulated Power Supply

Voltage range: 9 V~16 V
 Current range: 10A or more

12. Sweep Generator

Center frequency: 145 MHz
 Frequency deviation: Maximum ± 5 kHz
 Output voltage: More than 0.1 V
 Sweep rate: At least 0.5 sec./cm

13. Center Meter

Input sensitivity: 50 μ V or so

14. Detector

Construct the following circuit:

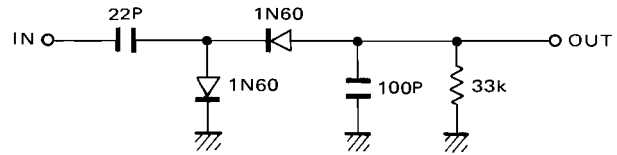

Fig. 12 Detector

ADJUSTMENT OF THE TR-7400A

1. ADJUSTMENT OF PLL

1.1 Test Equipment Used

- (1) RF VTVM
- (2) Frequency counter
- (3) DC voltmeter
- (4) DC power source

1.2 Preliminary CK of VCO & PLL

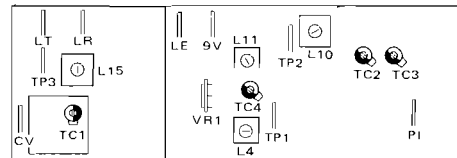

VCO Unit

If this check is performed successfully, it is not necessary to perform sec. 1.3 step 1~11. It should be stressed not to turn factory sealed parts.

1. Set TR-7400A to 146.00 MHz simplex.
2. Adjust VR1 on VCO to measure 9.00V at 9V terminal.
3. Adjust TC1 inside metal box on VCO to read 5.00V at CV terminal.
4. Check for 2.560000 MHz ± 20 Hz at TP1 on PLL board adjust TC1 if necessary (must use 33 pF cap at TP1).
5. Measure frequency at LR terminal on VCO. Adjust TC3 for 135.3000 MHz ± 100 Hz. Adjust TC2 for 135.3050MHz ± 100 Hz with 5k/0 control in 5k position.
6. To set TX final frequency TX and adjust L3 on TX board for final frequency.

1.3 Adjustment The VCO Unit (X50-1370-10)

- (1) Set the frequency to 146.000 MHz. Set the other controls at any positions.
- (2) Adjust the DC voltage across the 9-V terminal to 9 V (8.8 ~ 9.2V) with VR1.

ADJUSTMENTS

- (3) Connect the VTVM to terminal TP2 and adjust the core of L10 180° counterclockwise from the point where oscillation begins.
RF voltage of TP2 = 0.7 ~ 1 V
- (4) Adjust the core of L11 so that the RF voltage across terminal TP1 is maximum.
RF voltage at TP1 = 0.15 ~ 0.3V
- (5) Adjust the core of L11 so that the RF voltage at terminal PI is maximum, and then readjust the core of L4. RF voltage at PI = 1 ~ 2 V
- (6) Adjust TC1 so that the DC voltage terminal CV is 5 V.

Note: The PLL will work properly after steps (1) ~ (6) and the unlock indicator on the panel will go off.

- (7) Adjust the core of L15 so that the RF voltage at terminal LR is maximum.
RF voltage at LR = 0.3 ~ 1 V
- (8) Adjust TC1 so that the frequency at TP1 (measured through 33 pF) in the PD unit (X50-1380-10) is 2.560000 MHz ±20 Hz.

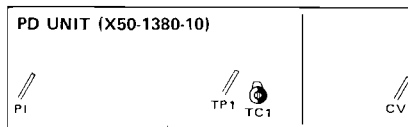

- (9) Measure the frequency at terminal LR.
TC3: 135.3000 MHz ±100 Hz
TC2: 135.3050 MHz ±100 Hz with 5k/0 control set at 5k
Adjust the frequency as noted above.
- (10) Set the MHz control to 5, adjust the cores of L4 and 11 so that the RF voltage at terminal PI is maximum. Reset the MHz control to 7 and adjust TC4 so that the RF voltage is 1.7V. Repeat these adjustments three times because the adjustment of TC4 affects with the setting of L4 and 11.
- (11) Set the MHz control to 6. Give the core of L15 three turns in the clockwise direction (put the core to middle of the form) so that the RF voltage at terminal TP2 in the RX unit (X55-1150-10) is maximum, and then adjust L-9 in the RX unit.
Repeat the adjustment three times or so because both coils are mutually related.
RF voltage at TP2 of RX unit = 0.8 ~ 1.2 V

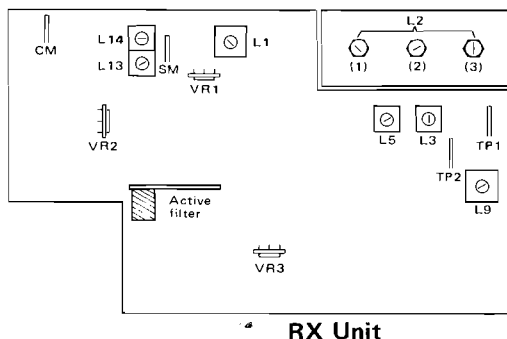

1.4 Check Point

- (1) Unlock circuit and its indicator.
 - A. When TP1 of VCO unit (X50-1370-10) is grounded with controls set arbitrarily.
 - (a) The unlock indicator on the panel should light.
 - (b) The RF voltage at TP2 of the RX unit (X55-1150-10) should be attenuated by 20 dB or more.
 - B. When the MHz control is turned rapidly, the unlock indicator should go on and off.
- (2) Frequency setting and its digital display circuit
 - A. When the MHz control is turned from 4 to 7, the frequency at terminal TP2 of the RX unit (X55-1150-10) should vary in steps of 1 MHz.
 - B. When the 100 kHz control is turned from 0 to 9 with the MHz control set at 7, the frequency at TP2 of the RX unit should vary in steps of 100 kHz.
 - C. When the 10 kHz control is turned from 0 to 9 with the 100 kHz control set at 9, the frequency at TP2 of the RX unit should vary in steps of 10 kHz.

- (3) Repeater circuit (±600 kHz TX shift) and its indicator

Set the frequency as given below.

145.99

147.00

When the repeater switch is set at -600 or +600 and at OFF (SIMP), frequency should be differ by 600 kHz only in the transmission mode.

(Frequency tolerance: within ±100 Hz) Check the frequency at TP3 of the VCO unit (X50-1370-10).

2. ADJUSTMENT OF RX UNIT

2.1 Test Equipment Used

- (1) DC power source
- (2) Sweep generator
- (3) Oscilloscope
- (4) Jig for helical stage
- (5) RF VTVM
- (6) SSG
- (7) AG
- (8) AF VTVM

2.2 Helical Adjustment

- (1) Ground TP2 and terminal LE of the VCO unit (X50-1370-10).
- (2) Connect the detector for helical adjustment to TP1 of the RX unit.
- (3) Looking at the waveform appearing on the oscilloscope, make adjustment in the following way. Adjust L1 and L2 (3 piston trimmers) alternately so that the markers appear as shown Fig. 14.

ADJUSTMENTS

- Note 1:** Adjust the core of L1 so that the waveform is symmetrical.
Note 2: The waveform should have three peaks.
Note 3: Adjust carefully so that the waveform is symmetrical.
 (4) Remove the wire used to ground terminal LE.
Note: See "Adjustment of PLL", (11) for the adjustment of L10.

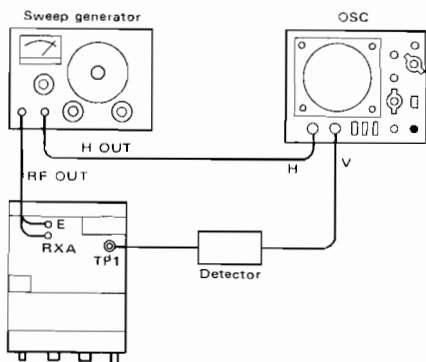

Fig. 13 Helical Adjustment

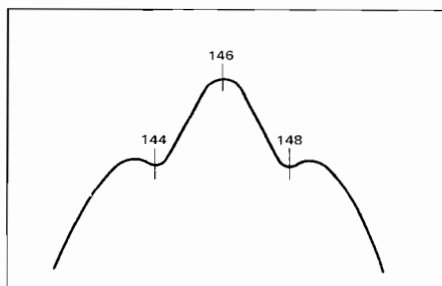

Fig. 14 Helical Output Waveform

2.3 Sensitivity Adjustment

- (1) Setting
 - (a) Adjust the source voltage to 13.8 V
 - (b) Set DEV of SSG to ± 5 kHz.
 - (c) Set modulation frequency of SSG to 1 kHz.
 - (d) Set controls as given below:
 146.00
 SQVR: turn counterclockwise fully
 Tone switch: off
 - (e) Observe AF output across 8-ohm dummy connected to EXT SP.
- (2) Receive 146.0 MHz (10 ~ 20 dB) from SSG. Adjust the tuning knob of the SSG for maximum S meter deflection.
- (3) Adjust a piston trimmer at the output side of L2 of the RX unit alternately with L3, L5 and L8 for maximum S meter indication.

2.4 Discriminator Adjustment

- (1) Adjust L13 and L14 of the RX unit repeatedly for maximum AF VTVM indication.
- (2) Disconnect the SSG output and connect a center meter to terminal CM. Adjust L14 alone so that the center meter indicates "0"

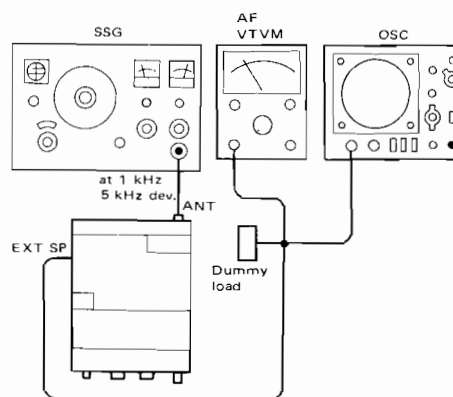

Fig. 15 Sensitivity Adjustment

2.5 Squelch Adjustment

- (1) Set the SQU knob at the 11-o'clock position and without receiving any signal, adjust VR2 of the RX unit so that reception noise just diminishes (by turning it in the diminishing direction).
- (2) When a signal of -6 dB is applied from the SSG, the squelch should open.

2.6 S Meter Adjustment

- (1) Set the SSG's output to 30 dB. Fine-adjust the SSG's tuning knob again for maximum S meter indication.
- (2) Adjust VR1 of the RX unit so that the S meter indicates "10"

2.7 Sensitivity Measurement

- 20 dB noise quieting sensitivity: 0.7 μ V or better
- S/N: 40 dB or more at 40 dB (1 mV) of input (1 kHz, 70% modulation)

2.8 Checking Tone Squelch Operation

- (1) Connect AG to SSG in order to operate SSG in external modulation. With SSG output set to 0 dB, apply AG signal of ± 0.5 kHz DEV. at 151.4 Hz.
- (2) Connect a 151.4 Hz active filter to the active filter socket of the RX unit.
- (3) Tune the SSG to 146.0 MHz. Make sure that reception is possible even when the tone switch is set to SQ. Make sure that reception becomes impossible when external modulation has been cut off. After checking, the test equipment should be disconnected.

ADJUSTMENTS

3. ADJUSTMENT OF TX UNIT

Technicians should be encouraged not to turn factory sealed transformers but to check each stage for output.

3.1 Test Equipment Used

- (1) Power source:
- (2) Power meter
- (3) Frequency counter
- (4) Linear detector
- (5) AG
- (6) RF VTVM

3.2 Adjustment of 10.7 MHz

- (1) Setting
 - (a) Adjust frequency to 145.5 MHz and turn off the repeater switch.
 - (b) Remove drive to final at "out" of TX unit.
- (2) Connect the frequency counter to TP1 of the TX unit. Key the transmitter and adjust L3 so that it read 10.700 MHz (10.7 MHz \pm 200 Hz).
- (3) Connecting the RF VTVM to the same TP1, adjust L7 and L8 for maximum indication.
The core of L7 should be in the center of the core.

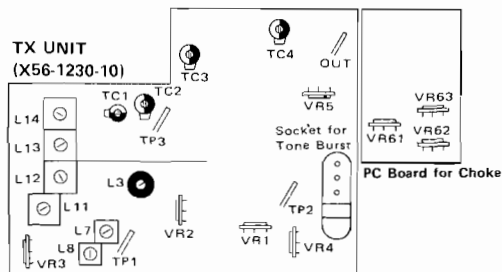

3.3 Adjustment of MIX Stage

- (1) Connect the RF VTVM to TP3 of the TX unit and key the transmitter. Adjust L11, L12, L13, L14, TC1 and TC2 repeatedly for maximum indication.
- (2) Set the frequency to 144.5 MHz and adjust VR61 on the choke circuit board for maximum indication.
- (3) Set the frequency to 146.5 MHz and adjust VR62 for maximum indication.
- (4) Set the frequency to 147.5 MHz and adjust VR63 for maximum indication.

3.4 Adjustment of Predrive

- (1) Set the frequency to 146.0 MHz and connect the power meter to the OUT terminal of the TX unit (50 ohms).
- (2) Adjust TC3 and TC4 of the TX unit for maximum indication. The output level should then be 1.3 W or more.

3.5 Adjustment of Tone Burst Time

- (1) Set the tone switch to BRU. Connecting an oscilloscope to TP2 of the TX unit in reception mode, plug a tone burst oscillating element of 1,800 kHz into the tone burst socket.
- (2) Watching the waveform on the oscilloscope, make sure that the level is about 0.12 V with the AF VTVM.
- (3) Watching the waveform, make sure that it diminishes about 0.5 second after the transmitter is keyed. If the delay is not as specified, adjust VR4 of the TX unit.

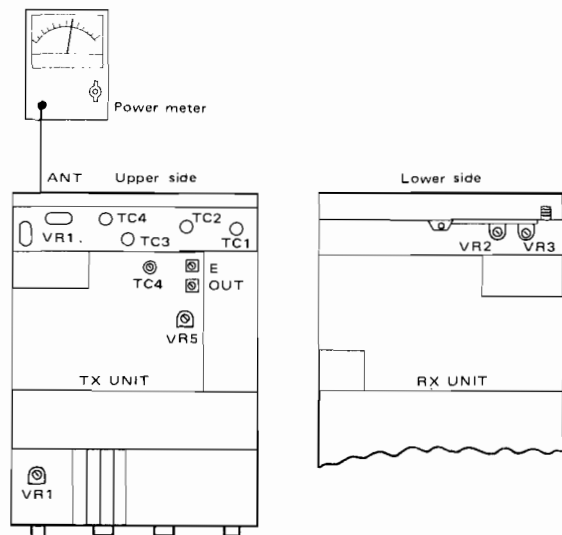

Fig. 16 Adjustment of PA Section, RF Meter and Low Power

ADJUSTMENTS

3.6 Adjustment of PA Unit

- (1) Connect the 50W wattmeter to the ANT terminal (type M).
- (2) Connect the lead which connects the PA unit with the TX unit to OUT of the TX unit.
- (3) Set the frequency to 146.0 MHz. Set the Hi/Low switch to Hi.
- (4) Key the transmitter and adjust TC4 of the TX unit, TC1, TC2, TC3 and TC4 of the PA unit for maximum indication.

Note 1: VR3 of the PA unit shall be turned fully counterclockwise.

Note 2: The maximum power shall be 28 W or more.

- (5) Set the frequency to 146.5 ~ 147.0 MHz, and adjust TC2 for maximum power output. It should be done to make the output at 147.9 MHz greater than that at 144.9 MHz. Make sure of the difference in power at 144.9 MHz and 147.9 MHz.
- (6) The power should be 25 W or more at Hi in between 144.0 and 148.0 MHz.

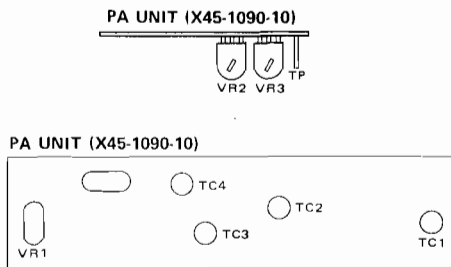

3.7 Adjustment of RF Meter

Adjust VR1 of the PA unit so that the RF meter indicates "8" at 146.0 MHz, Hi power position.

3.8 Adjustment of Low Power

- (1) Set the frequency to 147.9 MHz and the Hi/Low switch to Low. Adjust VR5 of the TX unit so that the power meter indicate 9.0 W.
- (2) Adjust VR1 of the display unit so that the power meter indicate 9.0 W at the frequency of 144.0 MHz with the Hi/Low switch set at Low.
- (3) The power should be 8~15 W at Low position in between 144.0 and 148.0 MHz.

3.9 Adjustment of DEV (Deviation)

- (1) Transmitting 146.0 MHz at Low and modulating it with microphone input of 1 kHz and 30 mV, adjust VR2 of the TX unit so that DEV become ± 5 kHz.
- (2) Similarly, adjust VR1 of the TX unit so that DEV become ± 3.5 kHz at a microphone input of 3 mV
- (3) Removing microphone input and setting the tone

switch to SQ, adjust VR3 of the RX unit so that DEV become ± 1 kHz.

Note: An active filter is needed as a jig.

3.10 Adjustment of Protection Circuit

- (1) Connect a DC voltmeter of 1 ~ 0.3 V range to terminal TP (on the filter circuit board). Adjust VR2 for minimum indication at a frequency of 146.0 MHz and the Hi setting.
- (2) Set the frequency to 144.0 MHz and remove the wattmeter. Adjust VR3 quickly so that current consumption become 4 A.

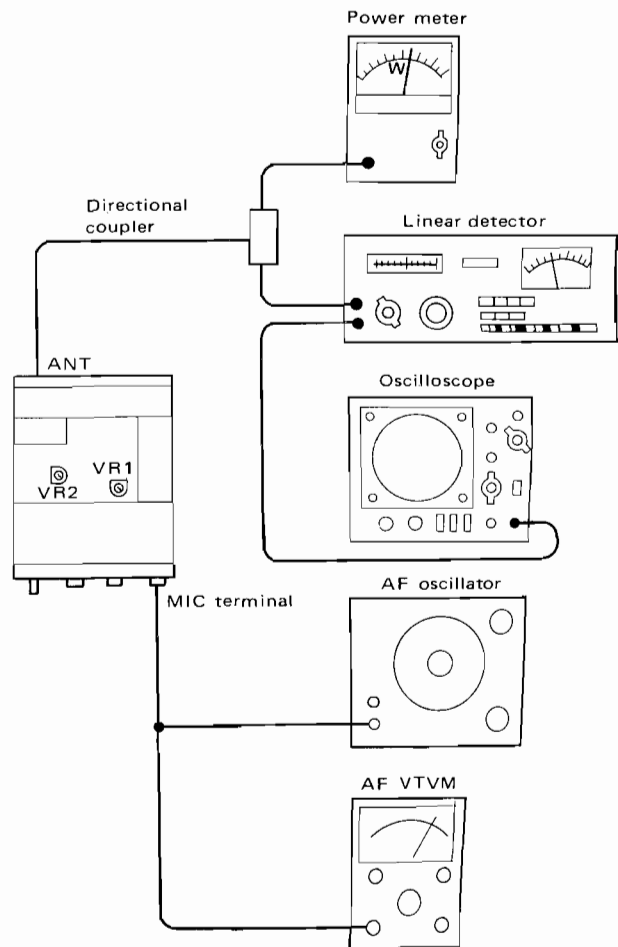

Fig. 17 Adjustment of DEV (Deviation)

ADJUSTMENTS

REFERENCE DATA

Example 1

TX MIC INPUT LEVEL VS DEVIATION

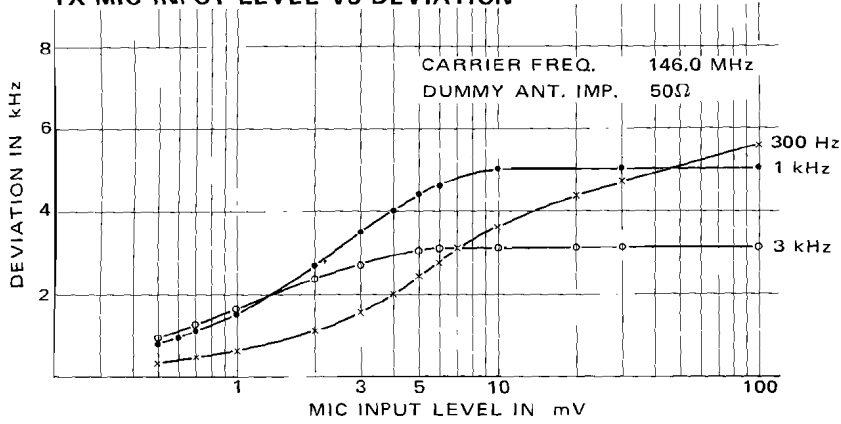

Example 2

RX SIGNAL TO NOISE RATIO, OUTPUT LEVEL VS ANTENNA INPUT VOLTAGE

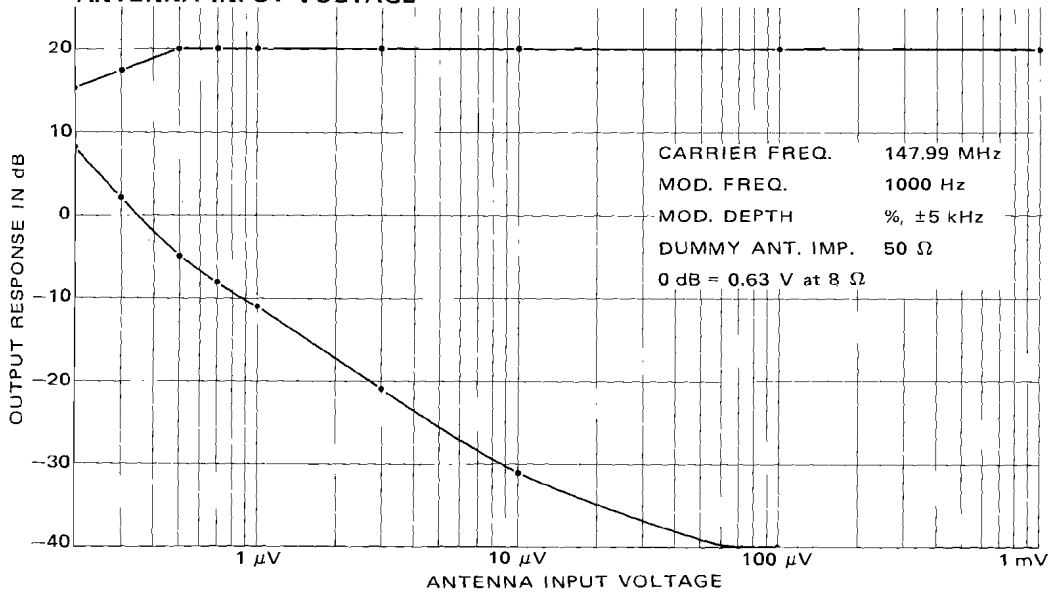

Example 3

RX S-METER SENSITIVITY

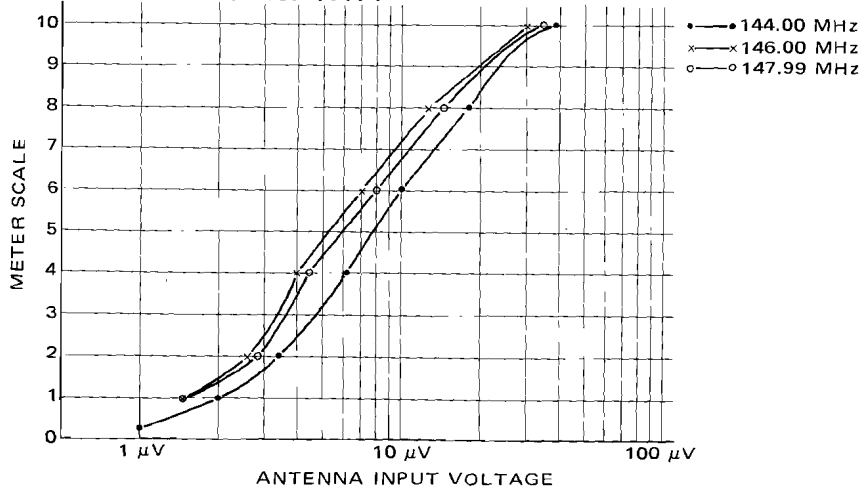

SCHEMATIC DIAGRAM

"X50-1370-10"

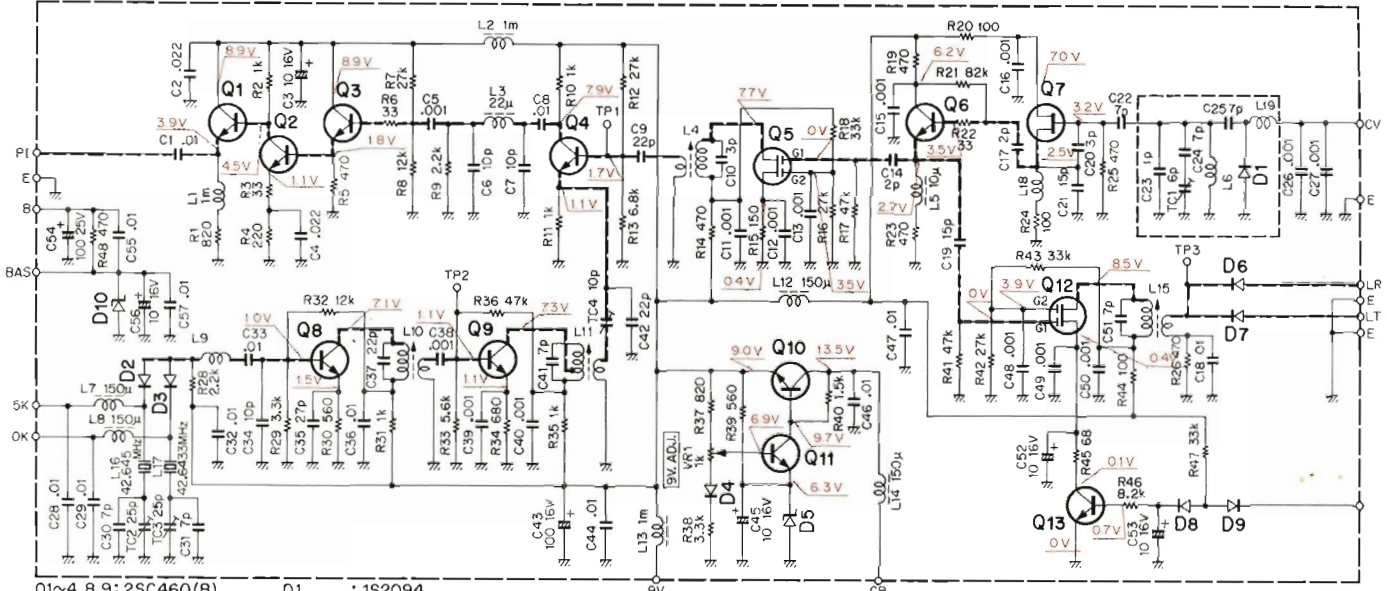

- | | |
|-----------------------|---------------------|
| Q1~4, 8, 9: 2SC460(B) | D1 : : 1S2094 |
| Q5, 12 : : 3SK41 (L) | D2, 3, 6, 7: 1S2588 |
| Q6, 7 : : 2SC785(Y) | D4, 8, 9 : : 1S1555 |
| Q10 : : 2SC496(Y, O) | D5 : : WZ-061 |
| Q11, 13 : : 2SC733(Y) | D10 : : WZ-090 |

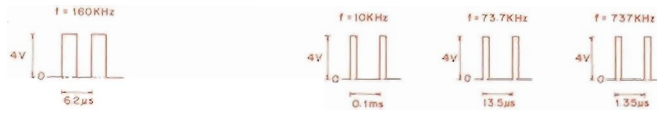

"X50-1380-10"

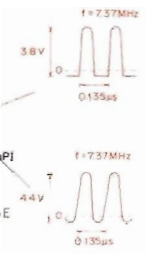
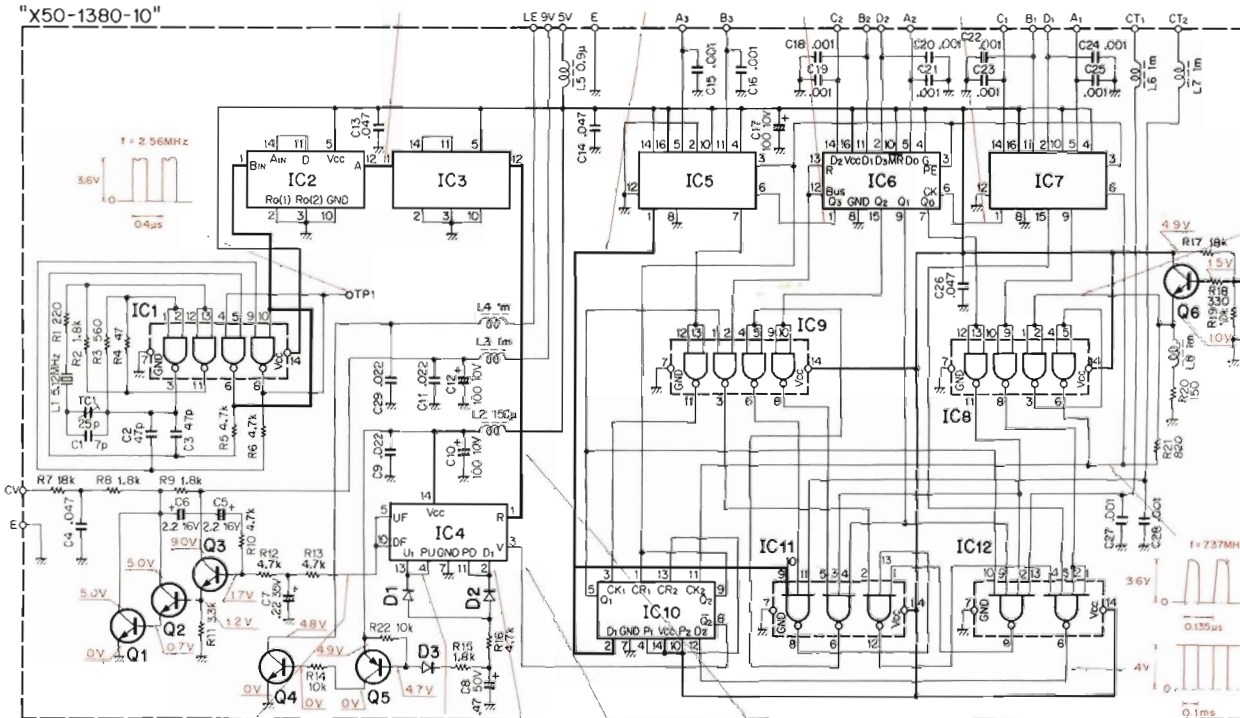

- IC1, 8, 9: TD3400AP, IC2, 3: TD3493BP, IC4: MC4044P, IC5~7: MC4016P (MC74416P), IC10: TD3474AP, IC11: TD3410AP
 IC12: TD3420AP, Q1, 2: 2SC458(B), Q3: 2SC1345(E), Q4: 2SC733(Y), Q5: 2SA495(Y), Q6: 2SC460(B), D1~3: 1S1555

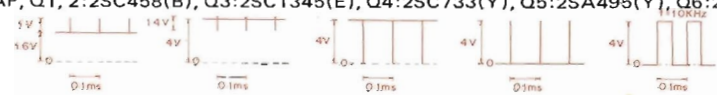

SCHEMATIC DIAGRAM

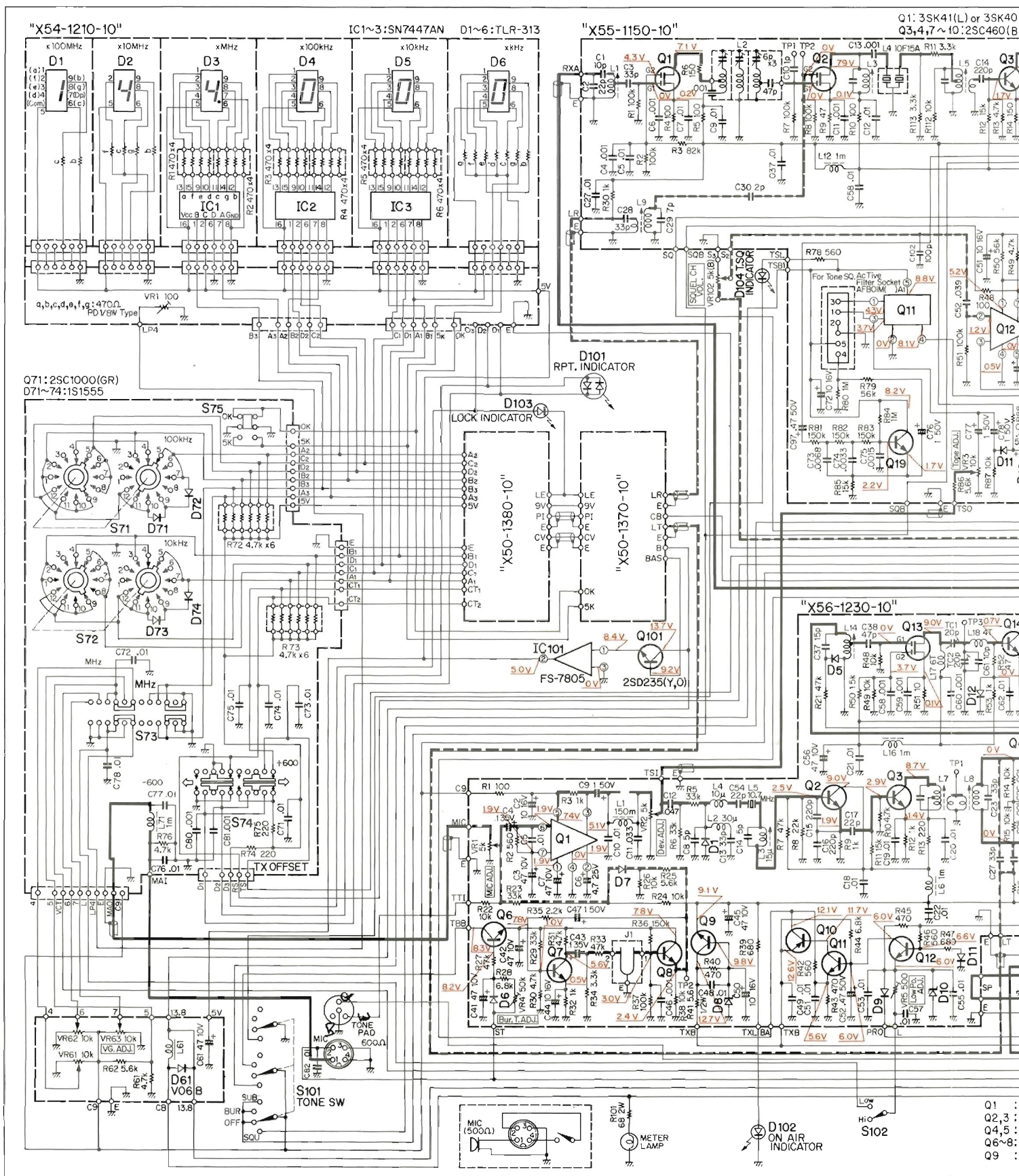

- Q1 ..
- Q2, 3 ..
- Q4, 5 ..
- Q6~8 ..
- Q9 ..

L) or 3SK40(L) Q2:3SK41(L,M) Q5,6,15,24,25:2SC1000(GR) Q11:H8D5022 Q16:2SC734(Y) Q21:2SA495(Y,O)
 :2SC460(B) Q13,14,19,20,22,23,26,29:2SC458(B) Q12:TA7120P Q17,18:2SD235(Y) Q27,28:2SC496(Y,O) Q30:2SC945(O,R)

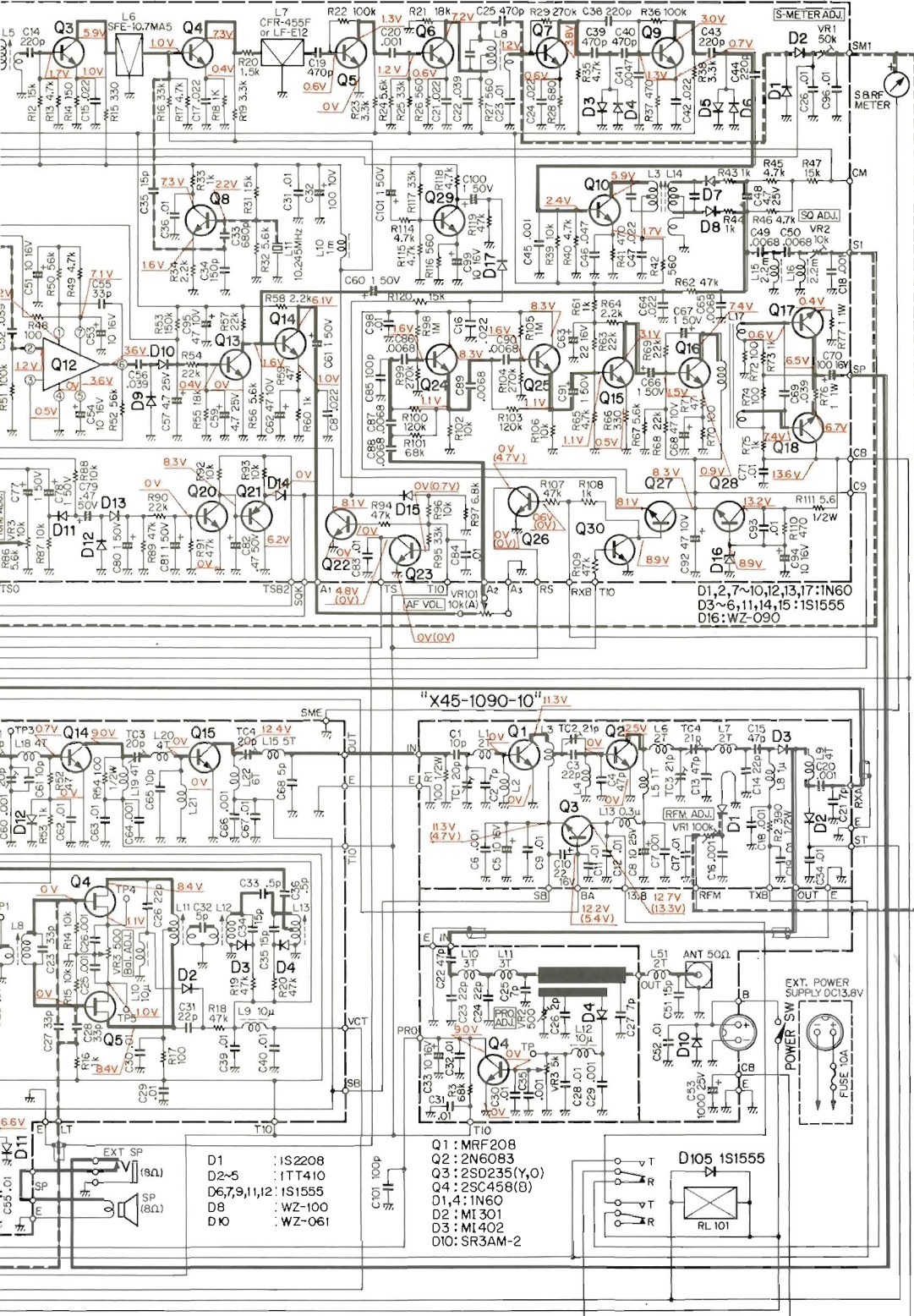

- D1 : 1S2208
- D2-5 : 1T7410
- D6,7,9,11,12 : 1S1555
- D8 : WZ-100
- D10 : WZ-061

- Q1 : MRF208
- Q2 : 2N6083
- Q3 : 2SD235(Y,O)
- Q4 : 2SC458(B)
- D1,4 : 1N60
- D2 : M1301
- D3 : M1402
- D10 : SR3AM-2

- Q1 : TA7061AP
- Q2,3 : 2SC460(B)
- Q4,5 : 2SK19(GR)
- Q6~8 : 2SC458(B)
- Q9 : 2SC496(Y,O)
- Q10 : 2SA496(Y,O)
- Q11,12 : 2SC734(Y,O)
- Q13 : 3SK41(L,M)
- Q14 : 2SC741
- Q15 : 2SC908

TR-7400A

2SC1000 (GR)
 2SC785 (Y)
 2SC733 (Y)
 2SA495 (Y)
 2SC734 (Y, O)

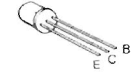

2SD235 (Y, O)

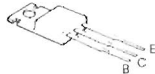

FS-7805



MRF208

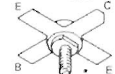

2N6083



2SC458 (B)

2SC460 (B)

2SC1345 (B)



3SK41 (L, M)

3SK40 (L)

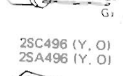

2SC496 (Y, O)

2SA496 (Y, O)



TD3400AP TD3410AP

TD3493BP TD3420AP

MC4044P SN7447AN

TD3474AP

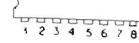

MC74416P



H8D5022



TA7120P

TA7061AP



2SC945 (O, R)



2SK19 (GR)



2SC741

2SC908



TR-7400A TERMINAL

L	=	Low Power
LP	=	Low Power
PI	=	Programmable Input
CV	=	Control Voltage
LR	=	Local RX
LT	=	Local TX
BAS	=	Base of Transistor
5 K	=	Crystal for 5 kHz Up
0 K	=	Crystal for 0 kHz
LE	=	Lock Error
CT1	=	Control Terminal No. 1
CT2	=	Control Terminal No. 2
TS	=	TX Switching
RS	=	RX Switching
MAO	=	MIC Amp Output
C9	=	Common 9 V
CB	=	Common B Line
TBB	=	Tone Burst B Line
TTI	=	Touch Tone Input
TXB	=	TX B Line
TXL	=	TX Lamp (on air)
BA	=	Base of Transistor
PRO	=	Protection
SB	=	Stabilized B Line
VCT	=	Voltage Control Tuning
ST	=	Stand-by
SM₁	=	S Meter
SP	=	Speaker
RXA	=	RX Antenna
SQB	=	Squelch B Line
TSB₂	=	Tone Squelch B Line
TS	=	TX Switching
T10	=	TX 10 Volt Line
RS	=	RX Switching
CM	=	Center Meter
TSO	=	Tone Squelch Output
SQ	=	Squelch Control
TSL	=	Tone Squelch Lamp
A₁	=	AF Output
SQK	=	Squelch Control

Distributed by
TRIO-KENWOOD COMMUNICATIONS, INC.
1111 West Walnut Street, Compton, California, 90220, U.S.A.

TRIO-KENWOOD COMMUNICATIONS, GmbH
D-6374 Steinbach/TS Industriestrasse, 8A West Germany

A product of
TRIO-KENWOOD CORPORATION
6-17, 3-chome, Aobadai, Meguro-ku, Tokyo 153, Japan.