

 **KENWOOD**

# TR-2200

## 2 METER FM HANDY TRANSCEIVER



**OPERATING MANUAL**

# TR-2200 OPERATING MANUAL

## CONTENTS

SPECIFICATIONS .....	3
FEATURES .....	4
SECTION 1. OPERATION .....	4
SECTION 2. MAINTENANCE .....	9
SECTION 3. TROUBLE SHOOTING .....	12
BLOCK DIAGRAM .....	13
CHASSIS' VIEW .....	14
SCHEMATIC DIAGRAM.....	17

# SPECIFICATIONS

## TRANSMIT SECTION

FREQUENCY	6 channels in 144MHz band
TYPE OF EMISSION	F3
RF OUTPUT POWER	1.0 watt
MODULATION	Reactance phase shift
MAXIMUM FREQ. DEVIATION	±15kHz
MULTIPLICATION	12 times
FUNDAMENTAL FREQ.	12MHz band
SPURIOUS RADIATION	1mW or less
ANTENNA IMPEDANCE	50 ohms
MICROPHONE	Dynamic type with PTT, 500 ohms

## RECEIVE SECTION

FREQUENCY	Same as transmit frequency
TYPE OF EMISSION	F3
CONFIGURATION	Double superheterodyne system
SENSITIVITY	1 $\mu$ V for s/n of 20dB or more
SELECTIVITY	10kHz or more (-6dB)
FILTER	Ceramic filter
INTERMEDIATE FREQ.	1st IF 10.7MHz 2nd IF 455kHz
AF OUTPUT	0.5 watts or more (distortion 10%); 1.0 watt max.

## SOLID-STATE COMPONENTS

TRANSISTORS	25
FET	1
IC	2
DIODES	19
POWER REQUIRED	
EXTERNAL GROUND	10.5 to 15.5VDC (standard 13VDC) Negative ground
POWER CONSUMPTION	
TRANSMISSION	Approximately 420mA at 12.0V
RECEPTION	Approximately 38mA at 12.0V
DIMENSIONS	135mm (W) x 58mm (H) x 181mm (D)
WEIGHT	1.7 kg (including 10 nickel-cadmium cells and microphone)

---

**Note:** The circuit and ratings may be changed without notice due to developments in technology.

# FEATURES

1. 6 FM transmit/receive channels in 144MHz band. 1W antenna output.
2. The smallest size unit in this class of transceiver.
3. Drip-proof design for maritime, foggy or rainy conditions.
4. All solid-state construction provides a long lifetime.
5. Either manganese battery or rechargeable nickel-cadmium battery available. Built-in AC-powered battery charger.
6. External DC power connector for mobile or other DC power available.
7. Multi-indicator (battery voltage check, transmit indication, and receive S-meter).
8. Diode switch for transmit/receive switching provides a stable operation.
9. Built-in transmit lowpass filter against TVI.
10. Voltage regulator circuit for major circuits.

# SECTION 1. OPERATION

## 1-1 UNPACKING

Carefully unpack the TR-2200 transceiver and check that the following accessories are included. (Refer to Fig. 1)

Carrying case ① .....	1
Carrying strap ② .....	1
Battery holder (6-cell holder) ③ .....	1
(Another 4-cell holder is built into the transceiver.) ④ .....	2
Charging cord ⑤ .....	1
External DC power cord ⑥ .....	1
Phone plug ⑦ .....	1
Microphone ⑧ .....	1

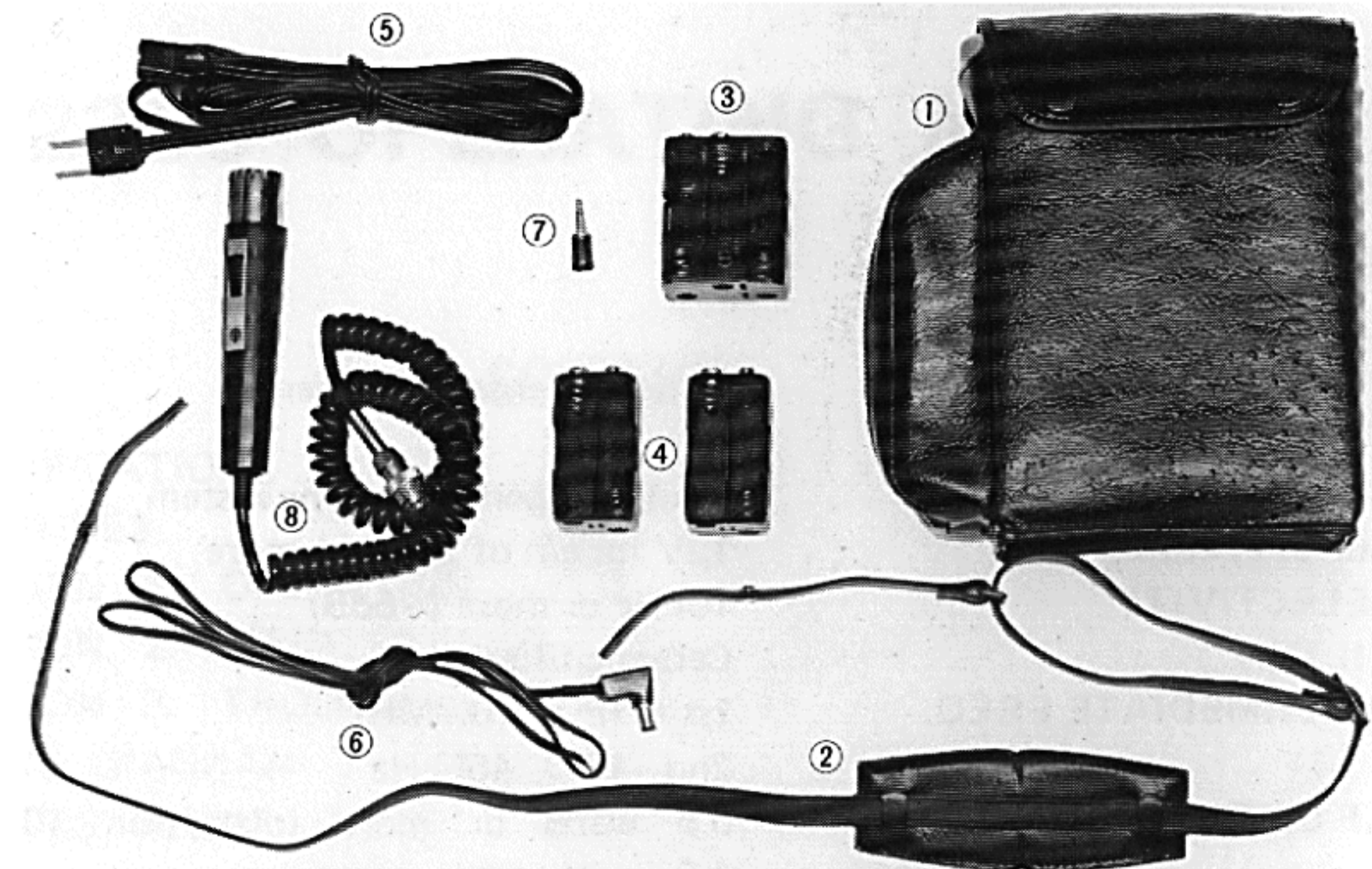

Fig 1. Accessories

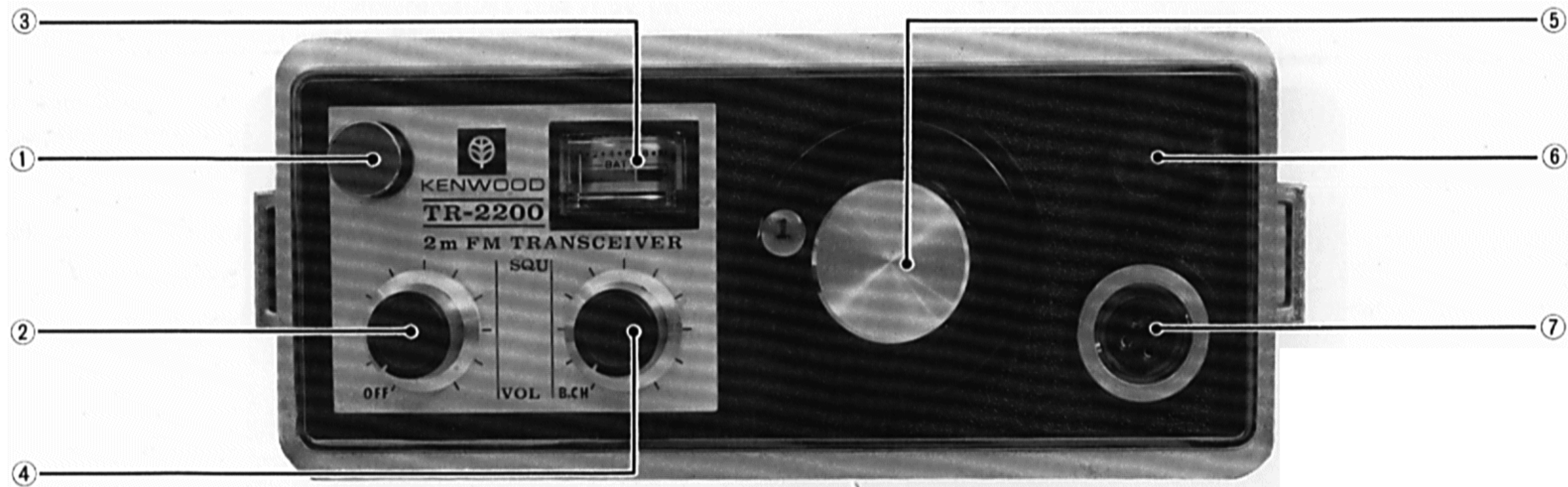

Fig2 Front Panel

## 1-2 CONTROLS AND FUNCTIONS (Refer to Fig. 2 and 3)

- ① WHIP ANTENNA: Use this built-in antenna fully extended.
- ② POWER/VOL: This provides power on-off and sound volume control. At OFF position, the set is off.
- ③ METER: Serves as a power voltage checker, transmission indicator, or an S-meter (Input Signal Intensity Meter). Performance of the above is automatic when the PTT switch is operated except for voltage checking.
- ④ SQUELCH/B.CH: Utilized to set the transceiver to voltage check for either battery or external power by turning to the fully counterclockwise position. To quench background noise, rotate in the clockwise direction to the mid-point where the squelch functions.
- ⑤ CHANNEL SELECTOR: There are 6 channels. The selected channel is indicated in the round window.
- ⑥ EXT. SP CONNECTOR: Connect the external speaker to this connector using the accessory plug.
- ⑦ MIC CONNECTOR: Connections are made for the transmission mode when the PTT switch of the accessory microphone is depressed.



**Fig 3 Rear Panel**

- ⑧ **CASE RETAINING HOOK:** Unhook before removing the case from the unit.
- ⑨ **BATTERY CHARGER CONNECTOR:** To be connected by the accessory charging cord when the nickel-cadmium battery cells employed require charging.
- ⑩ **EXTERNAL POWER SUPPLY CONNECTOR:** For external DC

- power operation (13VDC). Use the accessory power cord.
- ⑪ **CASE RETAINING HOOK:**
- ⑫ **EXT. ANT CONNECTOR:** For fixed-station use with an external antenna.

### 1-3 BATTERY INSTALLATION (See Fig4)

1. Unhook the clamp at the bottom of the transceiver casing to expose the battery holders.
2. When employing manganese or alkaline battery cells (1.5V per cell), load 8 cells into the 4-cell holders. When nickel-cadmium cells (1.2V per cell) are used, an extra 6-cell holder is also required to accommodate 10 cells. Battery polarity is marked on the holders. Observe the instructions carefully.
3. Hook the battery snap jacks to the battery holders, then return into the transceiver casing. The holders are held in position by the holder clamps. In checking the battery voltage refer to Par. 1-4.

### 1-4 VOLTAGE CHECK

To check the voltage, follow the procedures below:

1. Turn the SQUELCH/B.CH knob fully counterclockwise to the B.CH position.

2. Turn the POWER/VOL knob clockwise and turn the power on. The meter will then deflect.
3. If the deflection is within the shadowed area as shown in Fig. 5-(a), it indicates that the battery is insufficient for satisfactory operation and requires the replacement of the cells if the throw-away type or recharging if the rechargeable type (nickel-cadmium battery). See Section 2-4 for charging. When an external power supply is connected, the meter will automatically indicate the voltage of the external supply.

### 1-5 RECEPTION

1. Fully extend the whip antenna.
2. Set the SQUELCH/B.CH knob to a point just before it clicks into the B.CH position.
3. Turn the POWER/VOL knob clockwise, then turn further for operating volume. Operating noise will be heard.

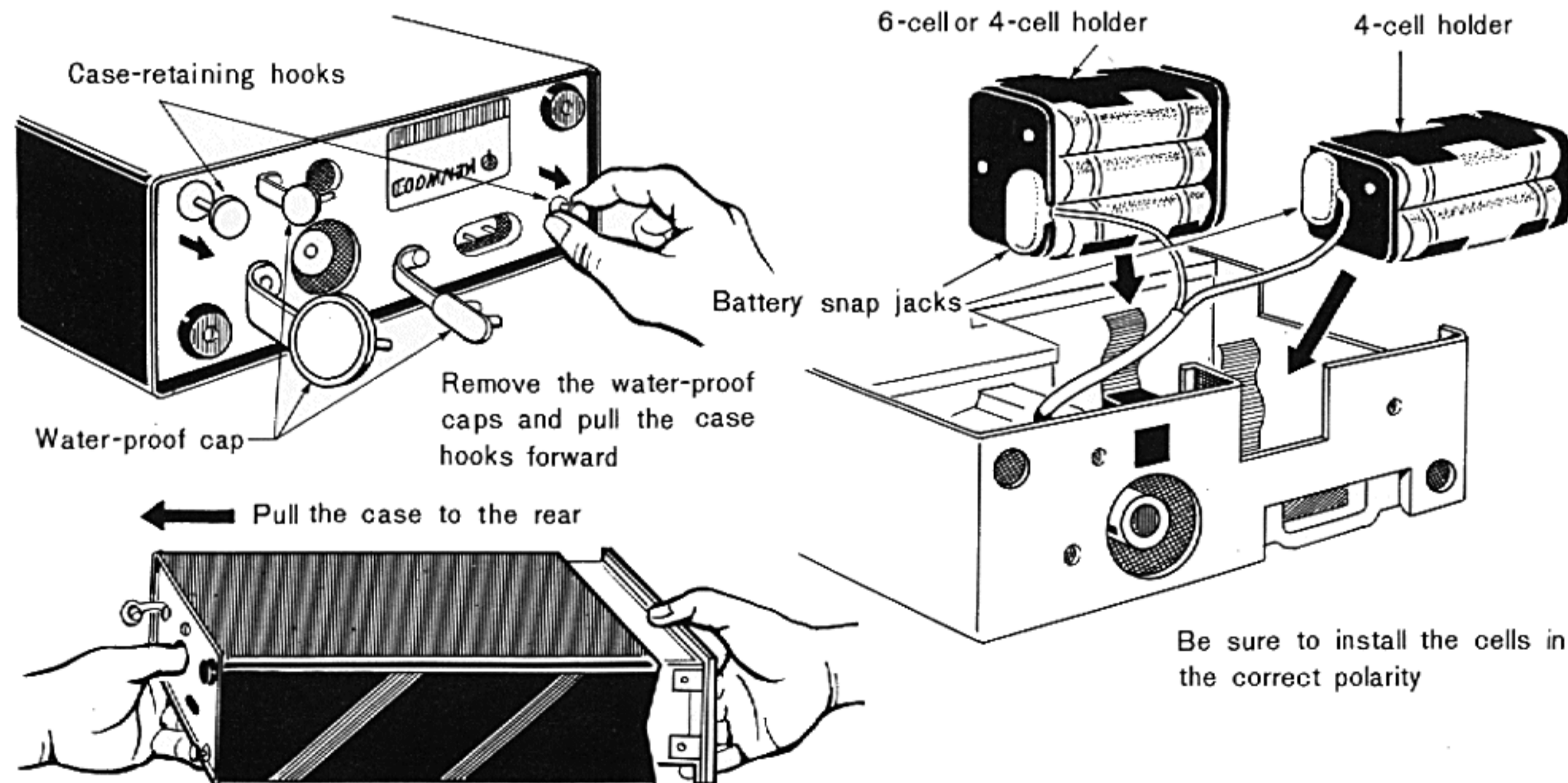

Fig 4 Battery Installation

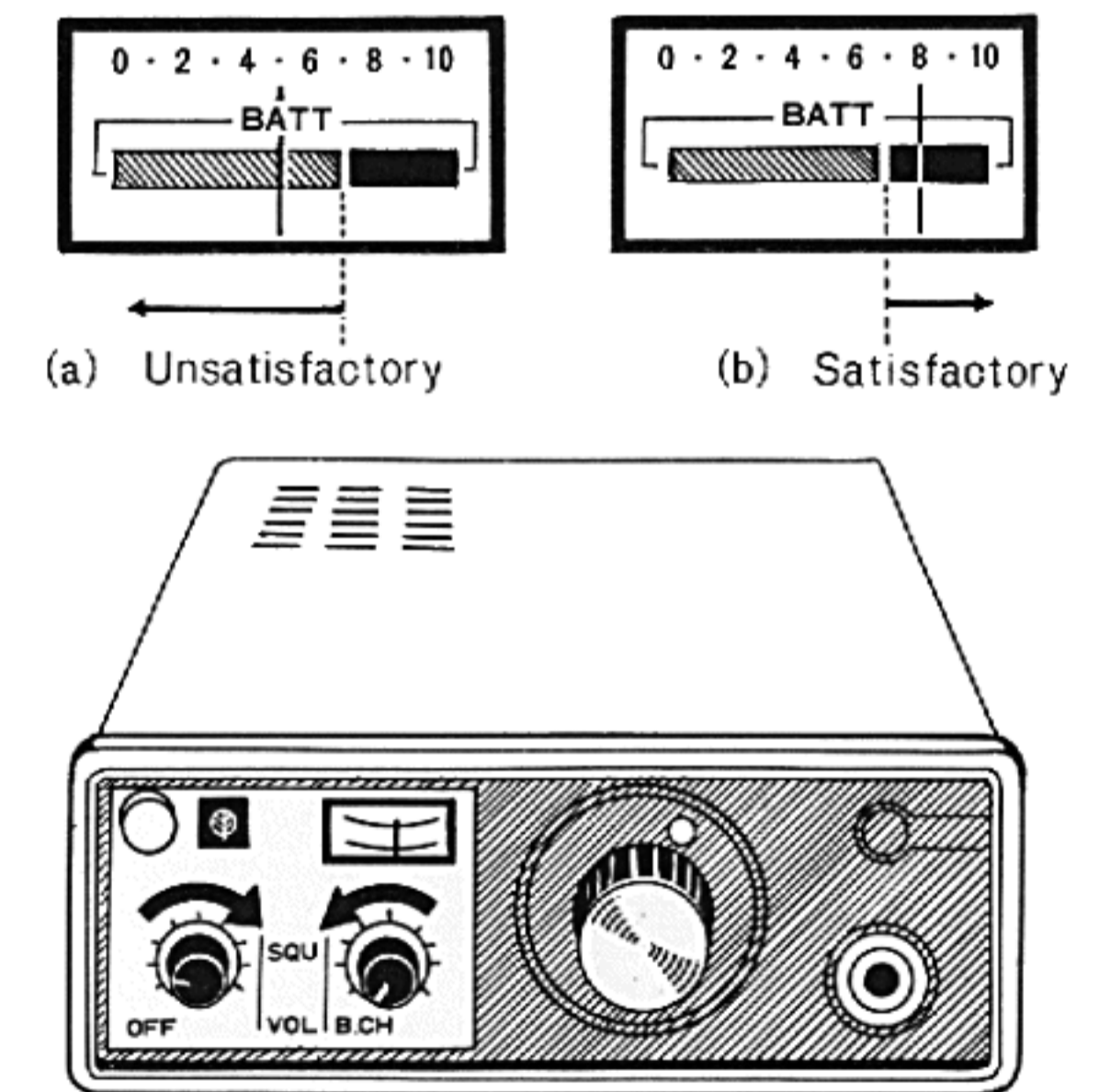

Fig 5 Voltage Check

4. Set the channel selector to the desired channel

All preparatory steps for reception are now complete. The multi-meter will indicate the strength of the FM signal received. With an input of 30dB, the meter will swing full scale. The volume may be increased by turning the POWER/VOL knob clockwise.

## 1-6 QUENCHING BACKGROUND NOISE (SQUELCH)

In the absence of receive signal, the FM receiver will produce background noise, which is very uncomfortable during stand-by.

This noise can be eliminated by turning the SQUELCH/B.CH knob clockwise until the noise disappears. Squelch should however be triggered off only when a signal arrives. Intermittent operation of the squelch indicates the necessity of turning the knob further clockwise.

## 1-7 TRANSMISSION

1. With the built-in antenna fully extended, set the channel selector to the desired channel and depress the PTT switch on the microphone. Then, the set will transmit indicating around 8 of the meter. The meter will indicate an increased apparent transmit power when the antenna is not fully extended. Note, however, that this is not the correct way of use and will result in an overload in the final stage power transistor, often causing damage. A retracted antenna or shorted antenna system will also cause a similar trouble.

## 1-8 CONSTRUCTION OF CHANNELS

In channel 1, 2 and 3, crystals are provided as table below.

Other channels (4 ~ 6 channel) are empty channels.

If expansion of channels is required, refer to SECTION 2 par. 2 - 5.

Channel Numbers and Frequencies

CHANNEL	TRANSMIT FREQ. (MHz)	RECEIVE FREQ. (MHz)
1	144.150	145.750
2	144.200	145.800
3	144.250	145.850



## SECTION 2. MAINTENANCE

### 2-1 EXTERNAL SPEAKER

An external speaker may be used in conjunction with the TR-2200 transceiver using the accessory plug. Plug connections are illustrated in Fig. 6. The output impedance of the external speaker (EXT. SP) is 8 ohms. The output circuit employs an OTL system, which requires extra precaution against short-circuit.

### 2-2 EXTERNAL ANTENNA

When an external antenna is to be connected to the transceiver,

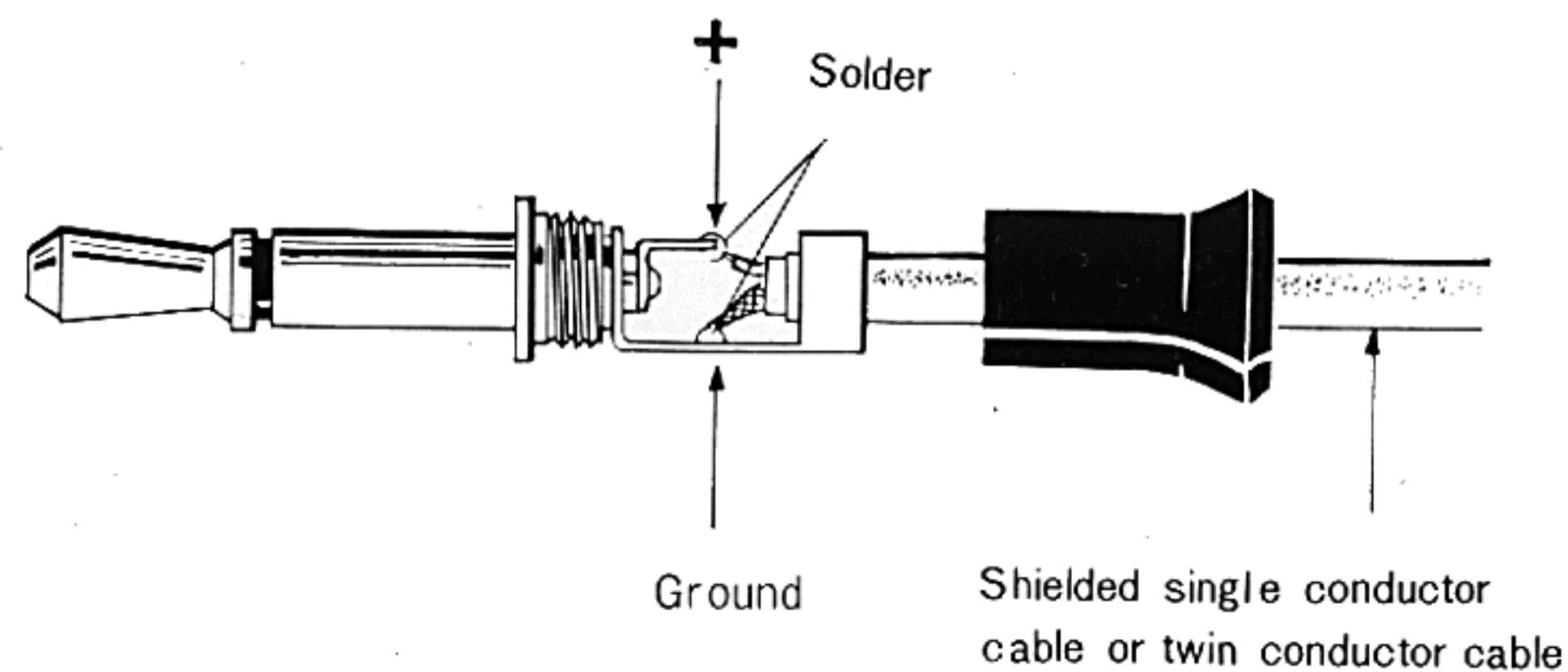

Fig 6 External Speaker Plug Connections

the built-in whip antenna must be completely retracted into the casing. A well-tuned 144MHz antenna should be connected to the EXT. ANT connector through a coaxial cable.

### 2-3 EXTERNAL POWER SUPPLY

External power supply to be used with the TR-2200 transceiver requires a current capability of more than 0.5A at 13VDC preferably with voltage regulator. The connections of the accessory external DC power cord shown in Fig. 7.

**Note:** During external power operation, the internal battery cells need not be removed during external power operation since the connection of the external DC power cord automatically disconnects the internal battery from the circuit.

### 2-4 BATTERY CHARGING

The TR-2200 transceiver contains a battery charger for rechargeable nickel-cadmium cells. To charge the battery, set the POWER/

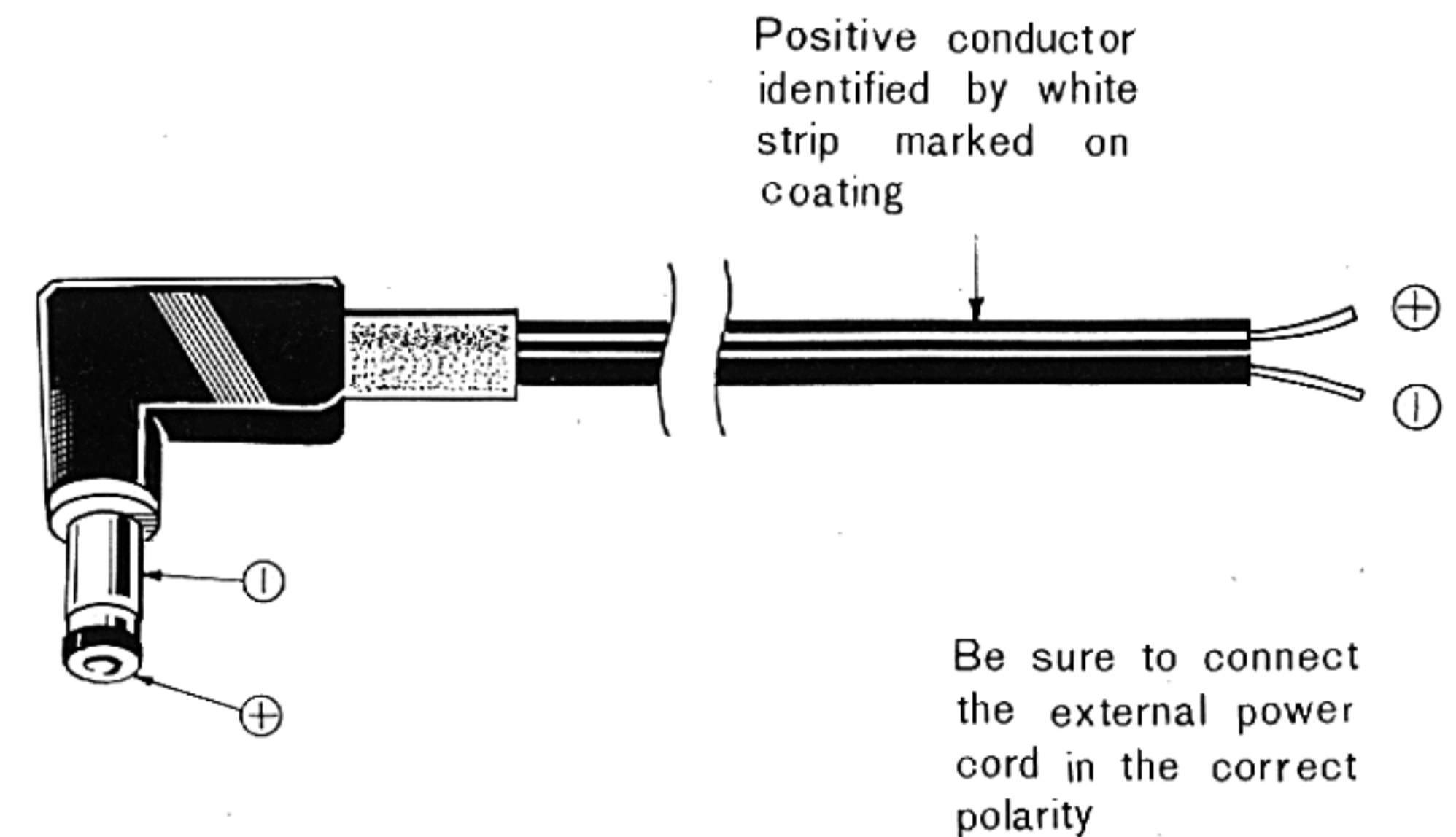

Fig 7 Polarity of External Power Cord

VOL knob to OFF, and connect the charging connector of the transceiver to a 220V AC commercial power outlet with the accessory charging cord.

The service limit of the rechargeable nickel-cadmium battery is 10V, or when the meter deflection falls between the black and red zone. The charging time required of a battery in this state will be 14 to 16 hours for full (100%) recovery, although the meter will indicate a normal value soon after charging is begun, due to the characteristic of the nickel-cadmium battery.

A fully charged battery is indicated by the meter deflection to the midpoint of the black zone.

Continued overcharging, say, for more than 12 hours is harmful to the battery. Acceptable charging temperature ranges between 0 and 45°C.

Use of an external power supply will not hinder charging as long as the charging cord is connected.

The battery charger powered by the charging cord cannot be alternative to the external power supply unless battery cells are installed.

## 2-5 EXPANSION OF CHANNELS (Refer to Fig. 8)

To expand the channels of this set using the spare receiving and transmitting crystals, proceed as follows:

1. Remove the case referring to Par. 1 - 3 BATTERY INSTALLATION.
2. Remove the two slide plates and the plastic cover over printed circuit board.
3. Install the crystals in position according to the indications on the plastic cover. Usable type of crystal is HC 25/U. Crystal oscillating frequency is the twelfth of transmit frequency, because of the multiplication (12 times) in this set.

Crystal (for reception) oscillating frequency calculated as under.

$$f_o = \frac{f_r - 10.7}{3}$$

$f_r$ : Desired receive frequency (MHz)

$f_o$ : Crystal oscillating frequency (MHz)  
Third overtone

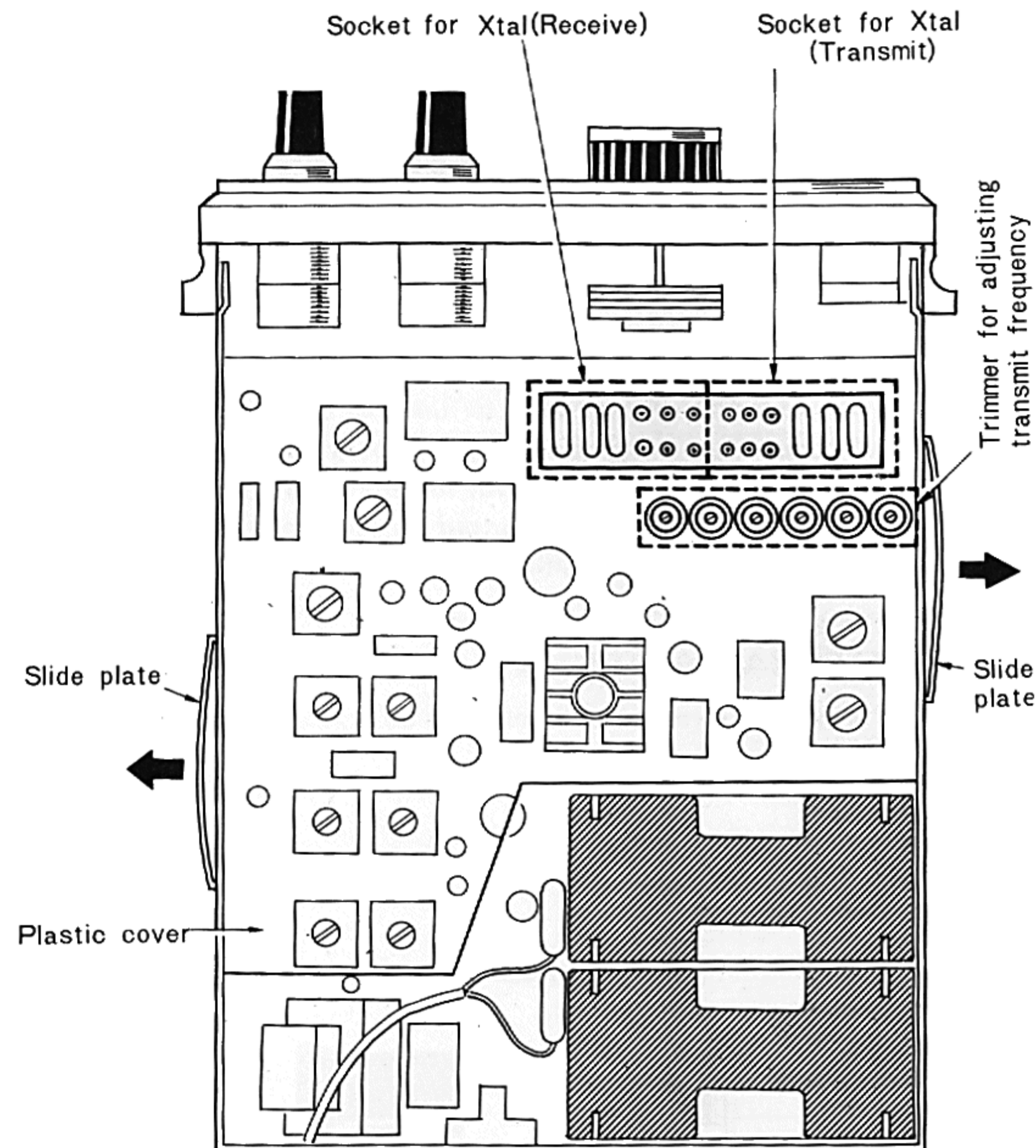

1. Remove the Slide plates
2. Remove the batteries
3. Remove the plastic cover
4. Xtal installation position referred to indications on the plastic cover

Fig 8 Expansion of Channels

4. Frequency adjustment must be performed in transmit section. Precise adjustment needs a frequency counter, but in general the following method can be applied. Namely, let your transmission observed by other stations and adjust the your set to obtain clear sound at the receiving station.
5. Adjustment procedures has been completed now. Restore the removed parts in position. In ordering the crystal, inform the oscillation circuit surely.

## 2-6 SUGGESTIONS

### 1. Television Interference

Although the TR-2200 transceiver is equipped with a low-pass filter and adequately shielded for TVI prevention, the FM signal emitted close to a TV set may cause interference if the TV signal in the area is weak. Keep the transceiver away from the TV antenna if at all possible. Two closely located transceiver sets will also produce a similar interference to each other.

### 2. Ground Polarity

The transceiver is negatively grounded on the chassis. Special caution is required especially when an external power supply is employed since incorrect connection will damage the transistors and diodes.

### 3. Floating Operation with Battery Charger

Floating operation with the battery being charged is possible. However, this will produce ripple noise in transmission and should be avoided.

### 4. Nickel-cadmium Battery

The rechargeable nickel-cadmium battery cells will cease to function when the per-cell emf drops to 1.0V, or the remaining energy is 1/10 of the full charge. One subsequent full recharge will provide an additional 3 hours or more of operation when the battery drain is in 1-minute transmission and 3-minute reception cycles.

Since the nickel-cadmium battery cells have an extremely low internal resistance, shorting or reverse polarity connection will produce heat, which will result in damage. Care should be exercised when installing the cells. A nickel-cadmium cell will serve for more than 300 dischargings when properly operated. This long service life provides a cost savings more than 10 times that of a regular manganese cell.

### 5. Vehicle Operation

The TR-2200 transceiver may be operated in an automobile utilizing the 12VDC vehicle power. Since mobile operation, however, will produce ignition noise in reception, use of a filter as shown in Fig. 9 is recommended.

### 6. Operation in Low Temperatures

The circuit design of this transceiver will insure normal operation in temperatures between  $-20^{\circ}\text{C}$  and  $+50^{\circ}\text{C}$ . When the temperature falls below  $-20^{\circ}\text{C}$ , however, covering the set with a protective bag is recommended to maintain a temperature suitable for normal battery service.

A regular manganese dry cell requires a higher operating temperature than a nickel-cadmium cell, and performance will drop in temperatures below  $0^{\circ}\text{C}$ .

Nickel-cadmium cells are recommended for extremely cold or freezing conditions.

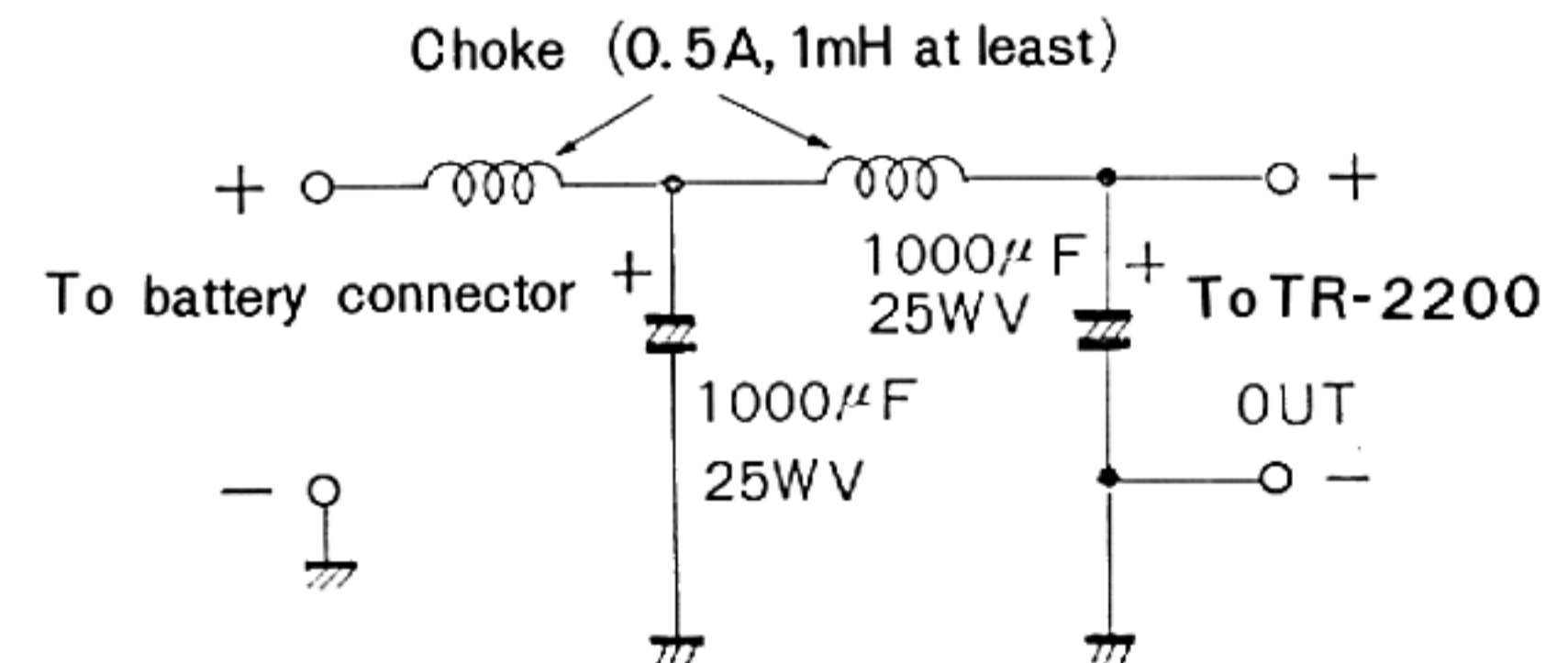

Fig 9

Preventing Circuit for Ignition Noise

# SECTION 3. TROUBLE SHOOTING

We recommend utilization of the our Service shops for repairs other than those listed in the following, leaving the critical trimmer capacitors and other semi-fixed controls intact.

## 3-1 TRANSMIT SECTION

### 1. No transmit output

Possible troubles for no transmission include an open coaxial cable, open or shorted connector or antenna connector, and defective power transistor.

### 2. Reduced transmitting capability

#### (a) Mismatched external antenna

Mismatching of the external antenna to the output of the transmitting section often appears as reduced service capability of the transceiver. Check the standing wave ratio (SWR) of the antenna system using an SWR meter. An SWR of 3 or more should be corrected to near 1.

#### (b) Low battery voltage

A battery voltage of below 12V will reduce the output power from the rated value.

### 3. No modulation

Open or shorted microphone connector.

### 4. TVI occurs

Since the TR-2200 transceiver contains an internal TVI filter, it will not interfere with television signals as long as the transceiver is in good operating condition. When the external antenna is mismatched to the transceiver due to employment of an inappropriate feeder other than a coaxial cable, it causes the TVI.

Therefore, corrective action to stop this trouble should begin with

checking whether the antenna employed is satisfactorily matched to the transceiver. A simple and reliable way of checking for mismatch is through use of an SWR meter.

## 3-2 RECEIVING SECTION

### 1. Reception possible but no response obtained on the channel

The most probable cause of no response to your call although both reception and transmission are apparently normal may be attributed to different frequencies between reception and transmission due to an error in fitting the crystal units into the channels.

### 2. Poor sensitivity

Check for an open or shorted antenna system and insufficient voltage level.

A defective antenna system will appear as no reception, whereas a low voltage level as reduced sensitivity accompanied by a decrease in transmitting power.

### 3. No sound output with good signal meter indication

Speaker connector disconnected or excessive squelch.

### 4. No power

(a) No continuity from the battery to the battery holder terminals, or the battery holder to the battery snap jacks.

(b) Incorrect connection of the external power supply to the transceiver.

# BLOCK DIAGRAM

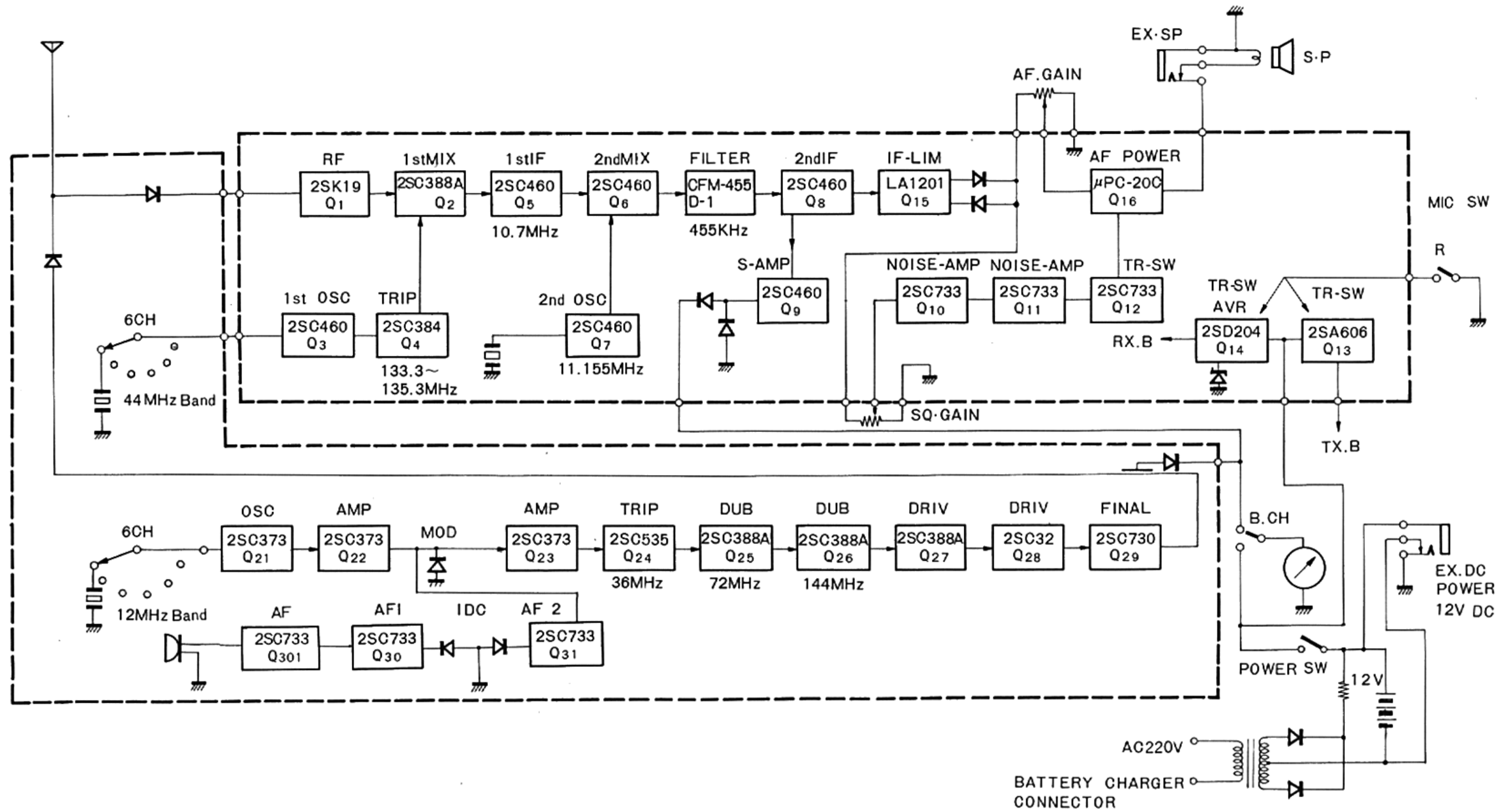

# CHASSIS VIEW (1)

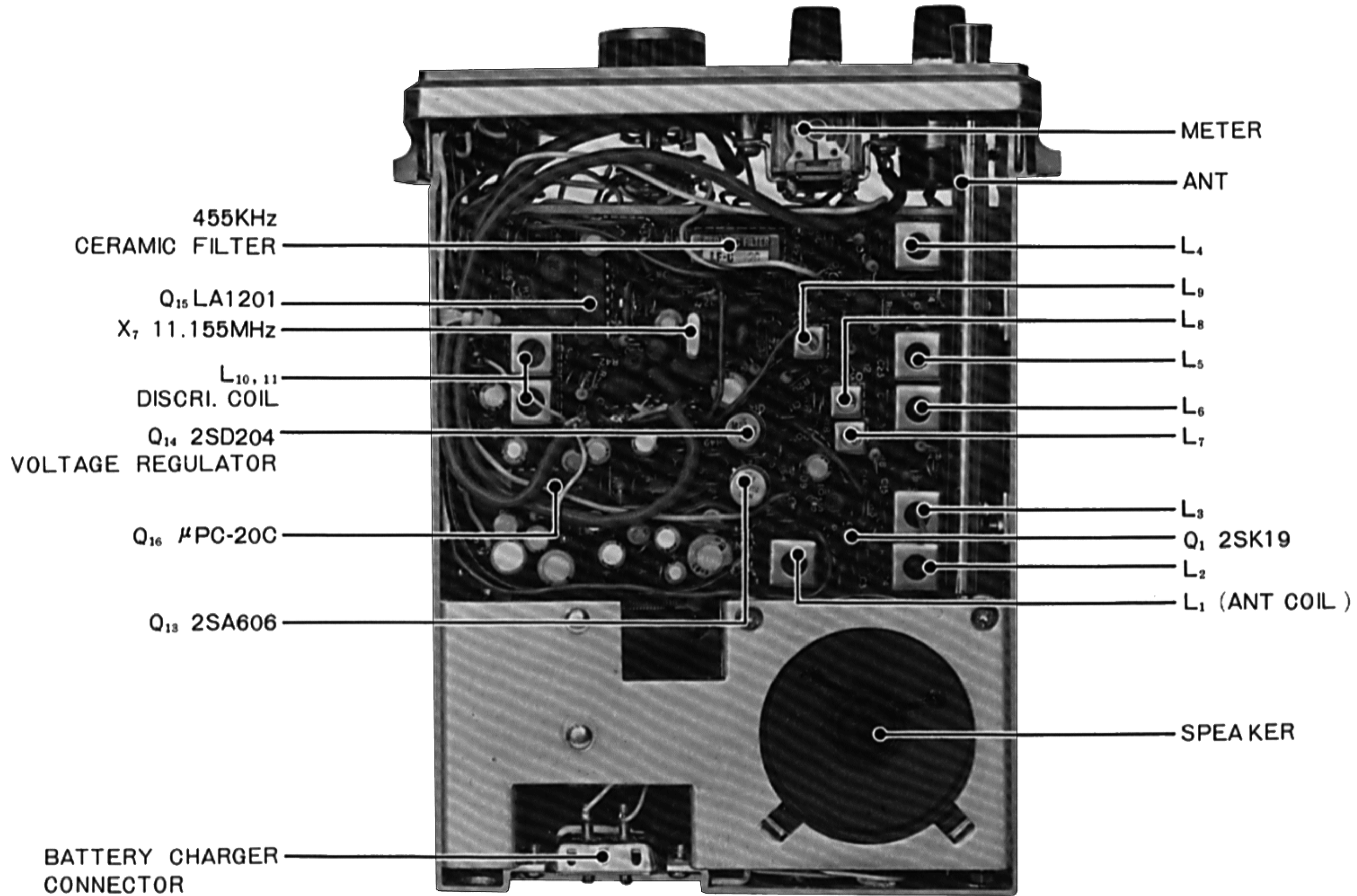

# CHASSIS VIEW (2)

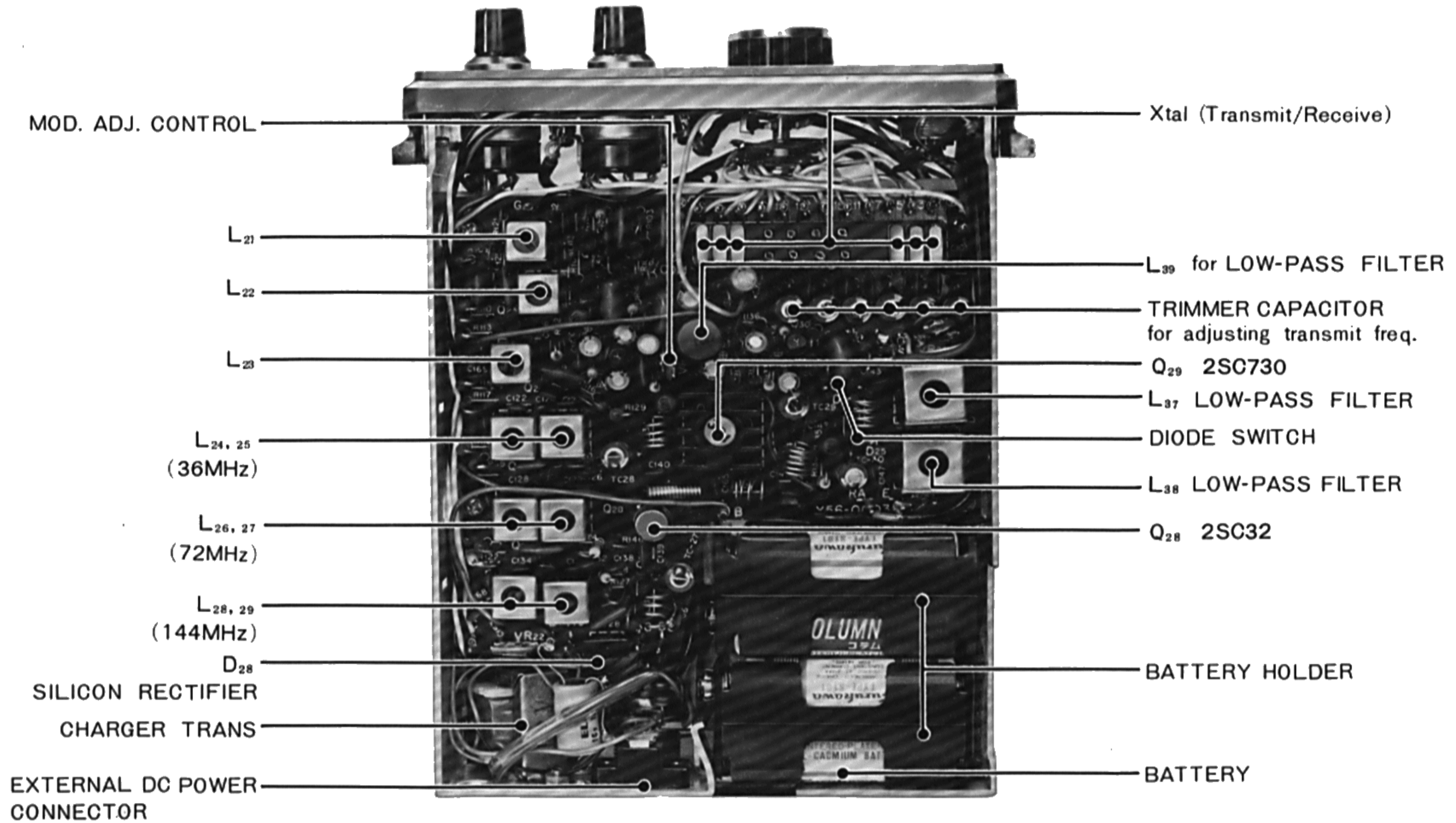

# NOTES



# SCHEMATIC DIAGRAM

## SCHEMATIC DIAGRAM of TR-2200

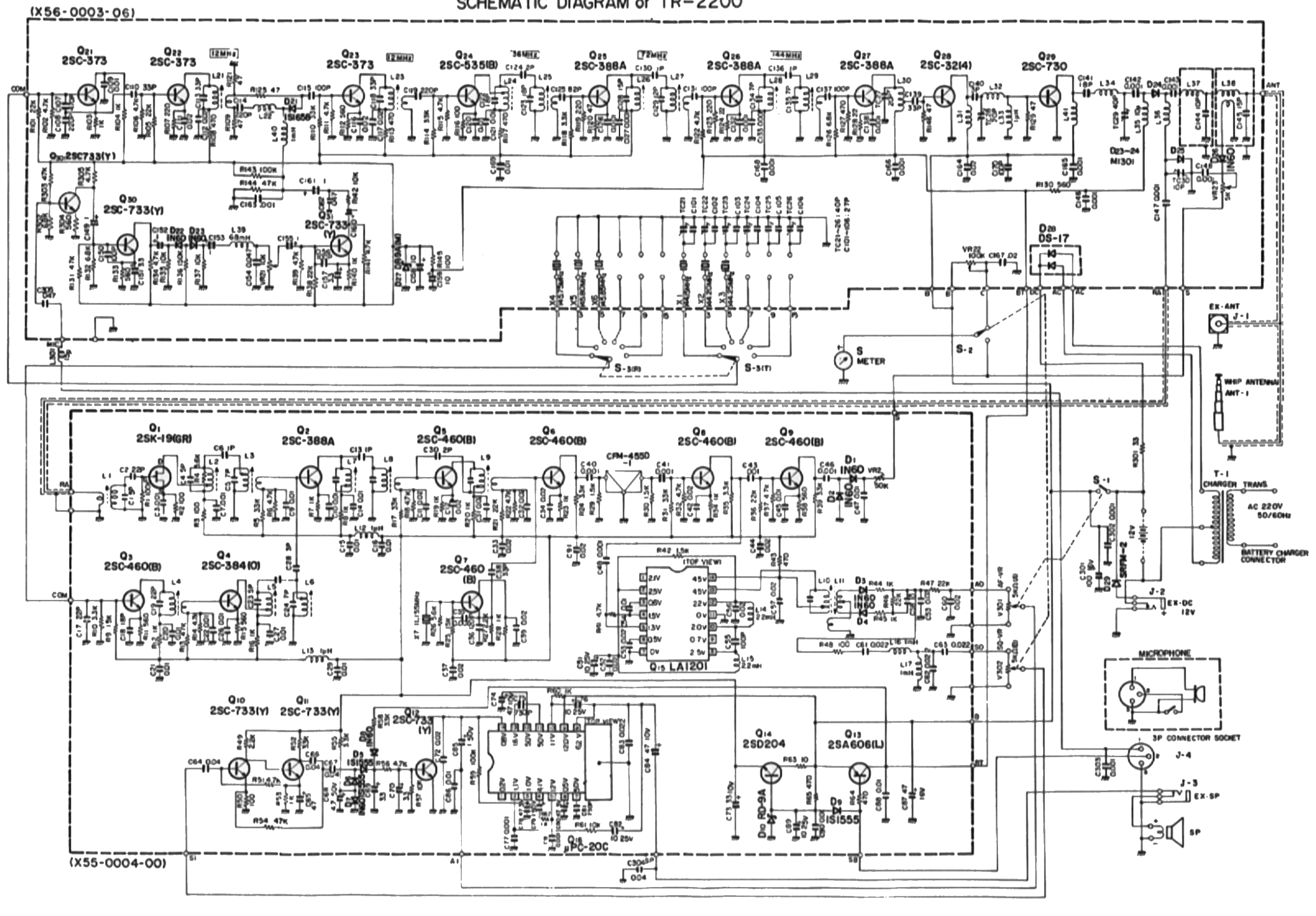



---

Manufactured by TRIO ELECTRONICS, INC., Tokyo, Japan