

WIDE BAND RECEIVER

RZ-1

SERVICE MANUAL

KENWOOD

©1988-1 PRINTED IN JAPAN
B51-3438-00(O)577

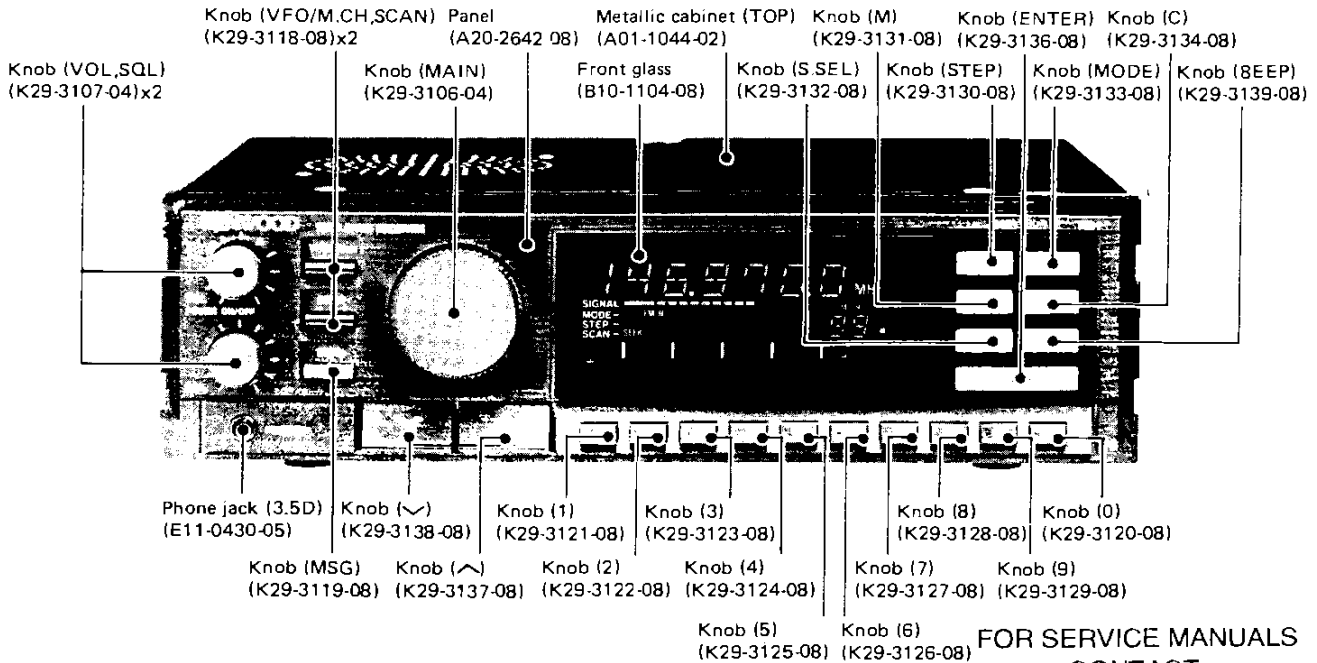

FOR SERVICE MANUALS
CONTACT:

MAURITRON TECHNICAL SERVICES

www.mauritron.co.uk

TEL: 01844 - 351694

FAX: 01844 - 352554

CONTENTS

CIRCUIT DESCRIPTION	2	IF (X59-3140-00)	53
SEMICONDUCTOR DATA	15	SQL (X59-3150-00)	53
DESCRIPTION OF COMPONENTS	18	SM (X59-3380-00)	53
PARTS LIST	21	IF UNIT (X48-3040-XX)	54
DISASSEMBLY	39	PLL UNIT (X50-3070-00)	56
PACKING	41	RF UNIT (X44-3050-00)	58
ADJUSTMENT	42	SCHEMATIC DIAGRAM	59
PC BOARD VIEWS/CIRCUIT DIAGRAM		BLOCK DIAGRAM	63
DISPLAY UNIT (W02-0811-08)	47	LEVEL DIAGRAM	65
CONTROL UNIT (X53-3110-XX)	48	TERMINAL FUNCTIONS	66
FM MPX (X58-3310-11)	51	SPECIFICATIONS	BACK COVER

CIRCUIT DESCRIPTION

GENERAL

The RZ-1 is equipped with a digital VFO capable of tuning 500kHz to 905MHz **M, W**, 500kHz to 824MHz **K** in 5kHz, 12.5kHz, and 20 or 25kHz steps. It is capable of receiving in the AM, FM-Narrow and FM-Wide modes. Additionally the Auto Mode will automatically select the proper mode for those frequency bands in which the mode/channel steps are fixed, such as the broadcast bands, etc.

In the FM-Wide mode the unit is capable of receiving stereophonic broadcasts. An output terminal is provided so that the unit can be easily integrated with our home audio component stereo equipment. A terminal is also provided to allow connection to a television monitor for video signal reception. The major features of this unit are:

- Continuous reception from 500kHz to 905MHz **M, W**, 500kHz to 824MHz **K**.
- 100 Memory Channels.
- 100 Message Channels that correspond to the normal Memory channels.
- Direct keyboard entry of frequency.
- Frequency selection via the Main Tuning control, UP/DOWN push buttons or numeric keypad.
- Perfect scanning.
- Built-in FM MPX.
- Built-in video output terminal **K**.

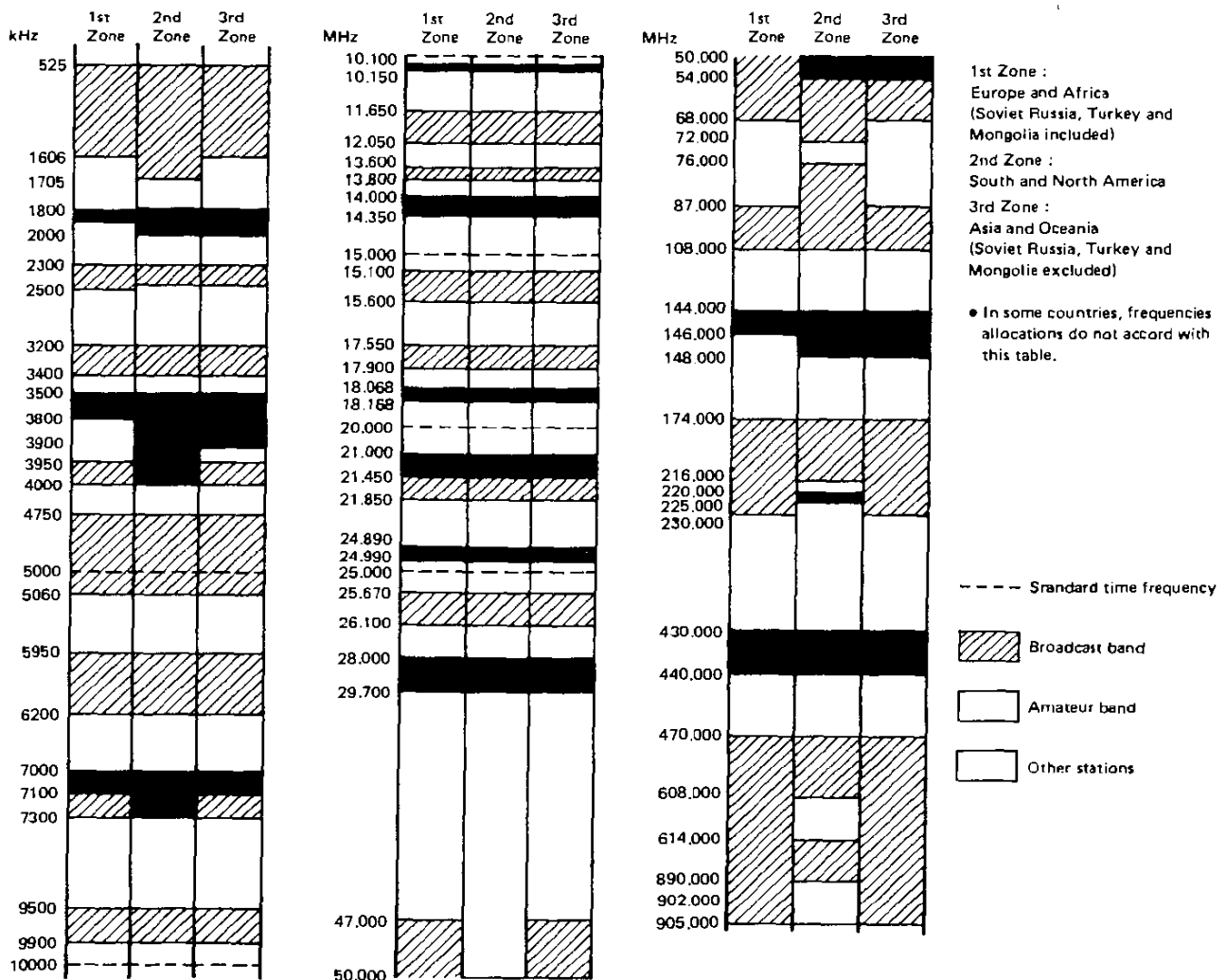

Fig. 1 Radio frequency allocation

FOR SERVICE MANUALS
 CONTACT:
MAURITRON TECHNICAL SERVICES

www.mauritron.co.uk

TEL: 01844 - 351694

FAX: 01844 - 352554

CIRCUIT DESCRIPTION

FREQUENCY CONFIGURATION

The RZ-1 utilizes triple conversion in the AM and FM-Narrow modes and double conversion in the FM-Wide mode. The incoming signal is mixed with the 1st local oscillator frequency of 46.25MHz to 950.75MHz **M, W**, 46.25MHz to 869.75MHz **K** to become the 1st IF of 45.75

MHz. The signal is then processed by the 2nd local oscillator frequency of 35.05MHz, to become the 2nd IF of 10.7 MHz. In the AM and FM-Narrow modes this signal is mixed with the 3rd local oscillator frequency of 10.245MHz, to become the 3rd IF of 455kHz. 5kHz shifts are performed at 35.05MHz.

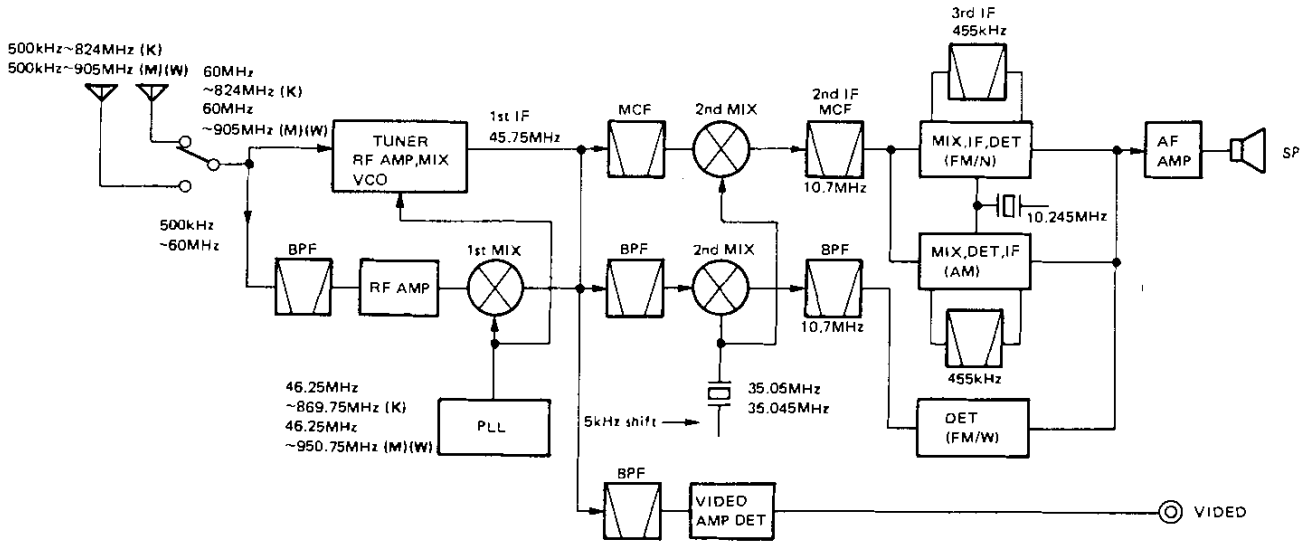

Fig. 2 Frequency configuration

CIRCUIT CONFIGURATION

• General

The incoming signal from the antenna is applied to one of 6 Band Pass Filters (BPF) in the RF unit, for frequencies in the 500kHz to 60MHz range. Signals above this range are applied to the tuner pack directly, bypassing the BPF section. Signals below 60MHz are then directly applied to the PLL unit where they are amplified by the 1st and 2nd RF amplifiers. The amplified signal is then applied to the 1st mixer. There the signal is mixed with the 1st local oscillator signal from the VCO (Voltage Controlled Oscillator) to from the 1st IF of 45.75MHz.

Signals in the 60MHz to 905MHz range and 60MHz to 824MHz range that enter the tuner pack are filtered, amplified and converted to the 1st IF signal of 45.75MHz. This 1st IF signal is distributed among the various video IF, FM-Narrow and FM-Wide circuits. The video IF signal is sent to the video detection circuit where it is converted into a video signal. The 1st IF signal for the FM-Narrow mode is applied to a Monolithic Crystal Filter (MCF) where undesirable components are eliminated, before it is fed to the 2nd mixer. This mixer combines the signal with the 2nd local oscillator signal of 35.05MHz to obtain the 2nd IF of 10.7MHz. 5kHz shifts are performed in the 2nd local oscillator. Additionally a switch between 35.05MHz

and 35.045MHz is performed at this stage.

The 2nd IF signal then passes through a 2 stage MCF, amplified, and applied to the TA7761F. This IC is used in the FM-Narrow mode. The signal is mixed with the 2nd local oscillator signal of 10.245MHz to become the 3rd IF of 455kHz. This signal passes through a 6 pole ceramic filter to obtain increased selectivity. Then the signal is amplified by a 5 stage limiting amplifier and then quadrature detected.

The 2nd IF signal used in the AM mode is amplified and applied to the LA1135M which is used for AM tuning. There it is mixed with the 2nd local oscillator frequency of 10.245MHz to become the 3rd IF of 455kHz. This signal is filtered and then detected.

The 1st IF signal in the FM-Wide mode is applied to the 2nd mixer after passing through a BPF. It is then mixed with the 2nd local oscillator frequency of 35.05MHz to become the 2nd IF signal of 10.7MHz. After additional amplification the signal passes through a ceramic filter and enters the LA1140. It is then amplified by 6 stage amplifier and is quadrature detected.

The various detector signals pass through an audio level control and are then amplified by an audio power amplifier and finally delivered to the loudspeaker.

CIRCUIT DESCRIPTION

• 5kHz Shift Circuit

If UHF signals in the 800MHz range are compared with a 5kHz reference the frequency deviation ratio would become so large as to exceed the capabilities of most PLL circuits.

For this reason the RZ-1 adopts 10kHz as the minimum comparison frequency. This means that movement of one PLL signal translates into a frequency shift of 10kHz. This results in difficulty in tuning signals in 5kHz steps. In order to allow tuning stations that use an intermediate step of 5kHz the 30.050MHz is shifted 5kHz while PLL data is kept constant, thereby achieving an apparent 5kHz tuning step.

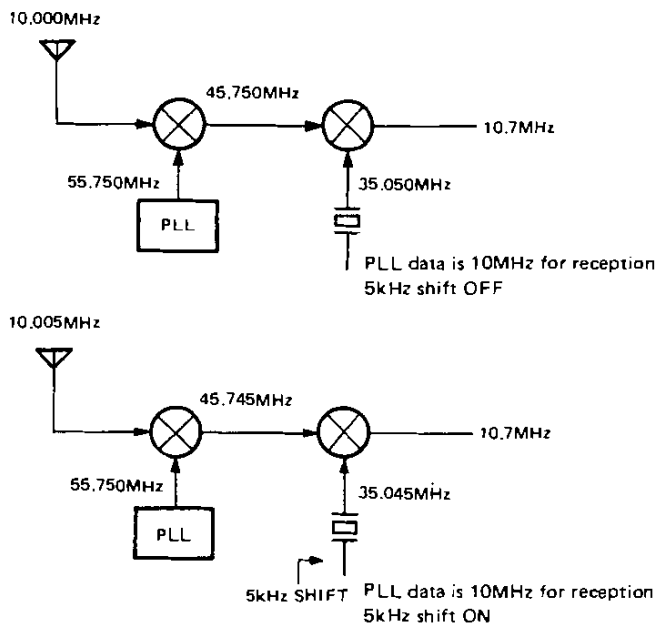

Fig. 3 5kHz shift circuit

• AM AGC Switchover Circuit (ATT SW)

The RZ-1 is equipped with an ATT SW which allows selectable AGC levels to increase sensitivity when listening to weak AM signals. This ATT SW controls the AGC voltages by varying the detection level of the LM1135M which is used in AM. In the presence of strong radio waves, such as those transmitted by local AM broadcast stations, distortion is likely to take place. Therefore, the receiver should be operated with the ATT SW turned ON normal listening.

• Squelch Control (FM-Narrow)

The noise component from the detector passes through a filter that is provided for the removal of the 2nd IF component (455kHz). The signal is then amplified twice and enters the detector. The resulting DC signal now passes through the squelch control which controls the audio muting circuit.

• S Meter Circuit

The S meter signals for AM, FM-Narrow and FM-Wide pass through the Control unit and are applied to the analog input of the LCD driver to cause the LCD bar graph to deflect.

1) FM-Narrow

The S meter voltage from the TA7761F which is used in the FM-Narrow mode is subjected to inverse amplification.

2) FM-Wide and AM

The S meter voltages from the LA1140 (FM-Wide) and the LA1135M (AM) are amplified twice. Loss of S meter control voltages is prevented by the use of this complementary amplifier.

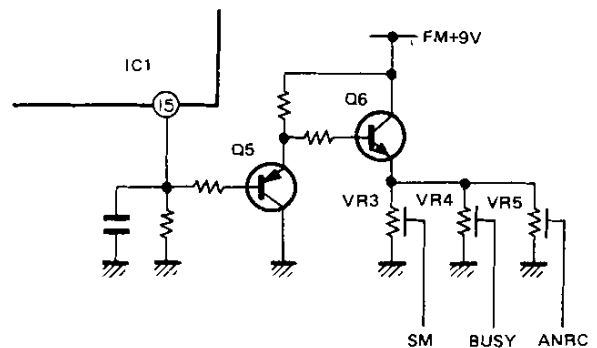

Fig. 4 S-meter circuit (FM-Wide)

• Audio Scan

The Audio Scan circuit captures modulated signals only in the FM-Narrow mode. The signal is amplified by an operational amplifier, detected, and the sent to the microprocessor on the Control unit. The microprocessor stops scanning through the use of the AF BUSY signal approximately 50ms after the signal has been detected.

FOR SERVICE MANUALS
CONTACT:

MAURITRON TECHNICAL SERVICES

www.mauritron.co.uk

TEL: 01844 - 351694

FAX: 01844 - 352554

CIRCUIT DESCRIPTION

● **ANRC (Automatic Noise Reduction Circuit)**

Deterioration of the S/N ratio in a weak electric field is greater than 20dB worse than in the stereophonic mode with respect to the S/N ratio in monaural reception, as can be see in Fig. 5. Generally, when a S/N ratio is less than 30dB to 40dB, the resultant noise sounds fairly bothersome. With this range of figures taken as a guideline, three domains, classified as A, B and C, according to the field

intensities have been taken into account, as shown in Fig. 5. SNC (Stereo Noise Control) is performed in domain A, likewise, HCC (High Cut Control) in domain B, and soft muting in domain C.

Figure 6 shows and example of the improvement in the S/N ratio this system in a weak electric field. Note that this function is only valid for the LINE OUT signal.

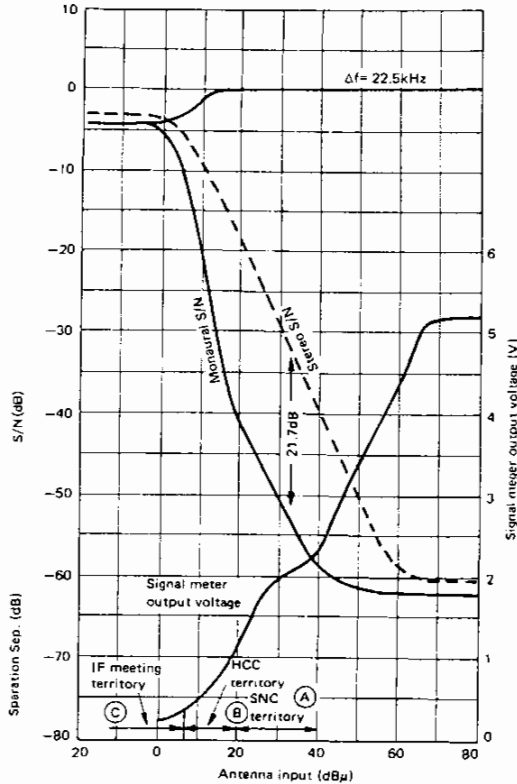

Fig. 5 SNC and HCC operative territory

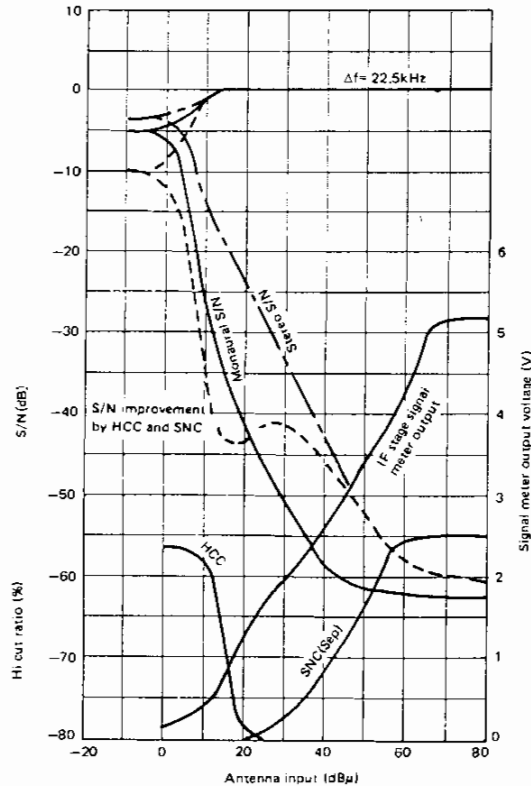

Fig. 6 Example of the improvement in the S/N ratio this system in a weak electric field

1) SNC (Stereo Noise Control) : Domain A

The pin 8 (SNC) of the LA3430 on the FM MPX sub-unit is designed to improve the S/N ratio in a weak electric field by changing the separation. A portion of the S meter output voltage from the LA1140 is used for control of this circuit. A shift, made by 2 diodes (D5 and D6) and a bleeder resistor is used to smoothly vary the separation in domain A in stereo and monaural signals. A time constant circuit (R24, C46 and diode D4) is used to obtain rapid response for blending and a slower response for separation when the electric field becomes weaker.

The output pin (11) of the KC-820A is applied to Q10 and thus to pin 8 of IC3, so that a momentary blending may occur to obtain monaural audio effect in the case of multipath signal reception.

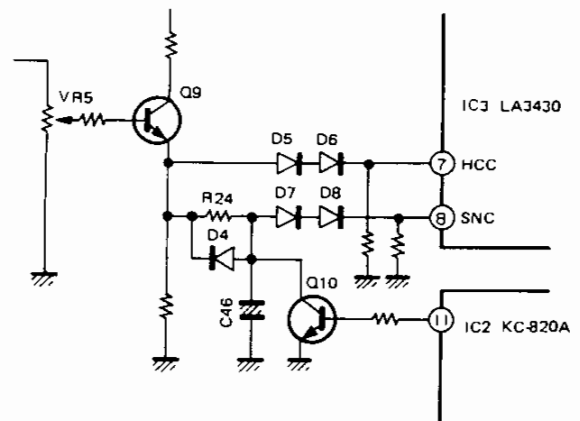

Fig. 7 SNC and HCC circuit

CIRCUIT DESCRIPTION

2) HCC (High Cut Control) : Domain B

In domain B it is possible that the S/N ratio may fall below 40dB even in the monaural mode. We can improve the S/N ratio, as perceived by the ear, by lowering the level of the frequencies above 7kHz. A smooth high-cut control is achieved for different ANT inputs by applying a portion of the S meter output voltage that is equal to pin 8 to pin 7 (HCC) of IC3. This high-cut control has no time constant circuit.

3) Soft Muting : Domain C

As the S/N ratio tends to deteriorate further in this domain, its improvement is accomplished by IF muting. The maximum attenuation for muting is set by VR1 (47k ohms) which is connected to pin 15 of IC1.

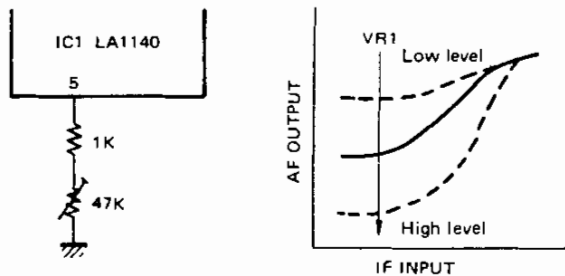

Fig. 8 Soft mute circuit

• MPX Demodulation Circuit

The signal detected by IC1 in the FM-Wide mode enters IC2, which is used for noise canceling, after passing through a buffer amplifier. It then goes through a gate circuit and enters IC3, the MPX demodulator. From there, the output emerges as the L and R audio signals.

• Band Information

Turning the rotary encoder causes band information (normally "H") corresponding to the selected frequency, to be sent from IC3 of the Control unit.

Band information on B1 to B6 which is normally a logic "H" is applied to inverters Q1 to Q6, become a logic "L" which is then used to control the HF BPF circuits.

When a "H" is applied to the inverters, an active "H" is supplied to the tuner pack, through 2 inverters, for Band information lines B7 to B10. (Refer to Fig. 9.)

The data for Band information lines B1 to B6 passes through diodes D12 to D14 to become VCH and VCL (normal "H"), which enters the VCOH and VCOL circuits of the PLL unit. The emitter of Q11 and the source of Q13, the VCOH oscillator circuit, usually remain open allowing no oscillation to take place. When a "H" is applied to these two transistor junctions from the VCH inverters Q14 and Q15, of the PLL unit, become "L", which connects the emitter of Q11 and the source of Q13 to ground. This causes the VCOH oscillator circuit to begin operating. (Refer to Fig. 10.)

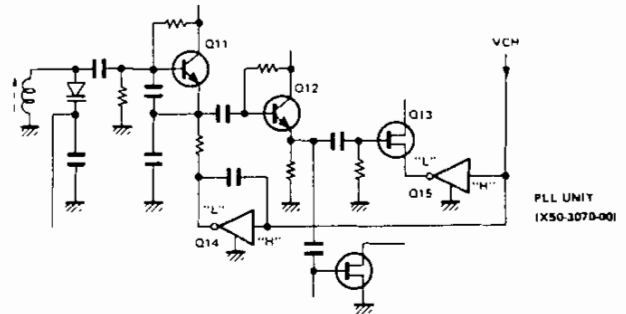

VCO will operate, when "H" level of Q14, 15

Fig. 10 VCOH circuit (68.0 to 105.765MHz)

FOR SERVICE MANUALS
CONTACT:
MAURITRON TECHNICAL SERVICES
www.mauritron.co.uk
TEL: 01844 - 351694
FAX: 01844 - 352554

CIRCUIT DESCRIPTION

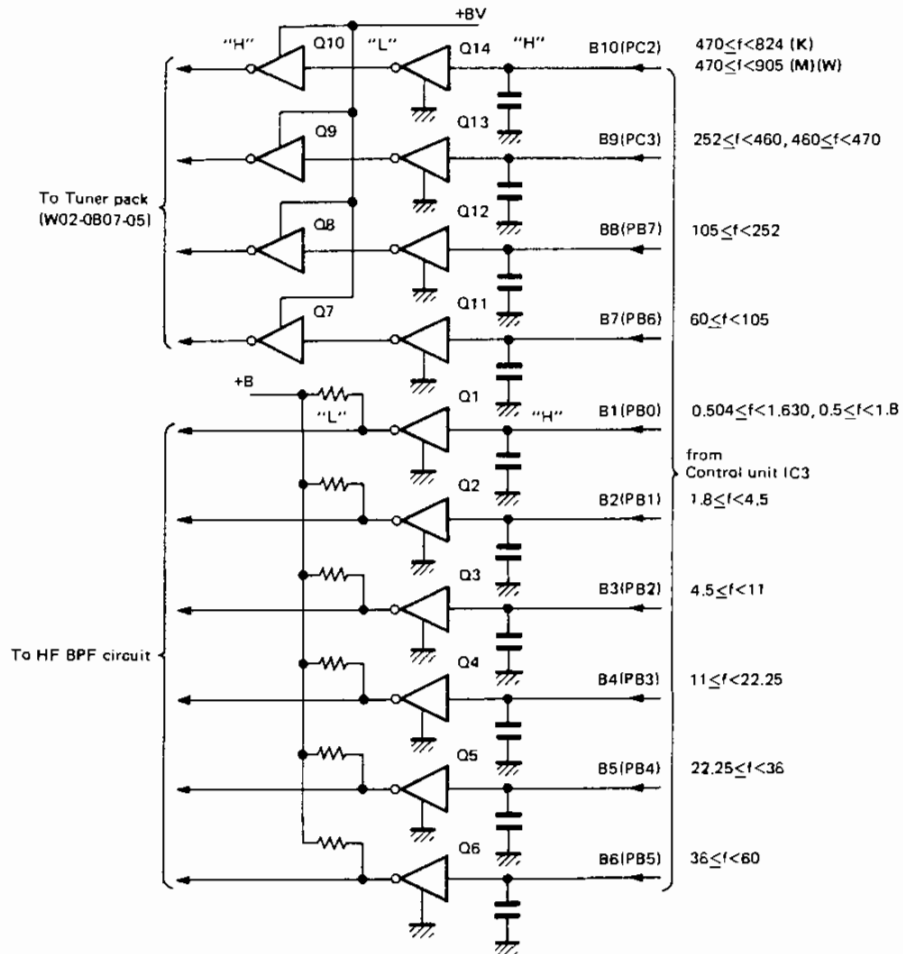

Fig. 9 Band information circuit

● **Voltage Changeover Circuit by Mode**

This is a circuit that switches the +8V bias voltage depending upon the selected mode. IC4 of the Control unit causes PB1, PB2, PB4 and PB5 to become "H" when the

MODE SW is switched from AM to FM-N to FM-W. Q9 to Q16 of the IF unit perform switching among the different modes supplying +8V to the proper circuits.

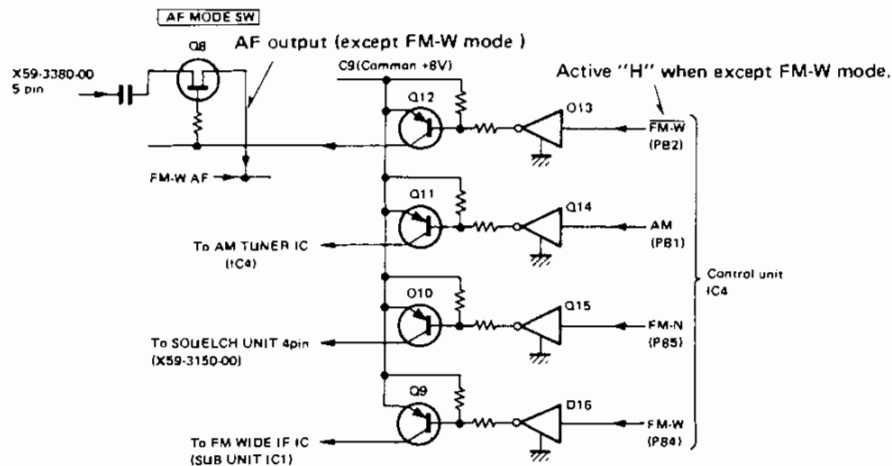

Fig. 11 Voltage changeover circuit by mode

CIRCUIT DESCRIPTION

PLL SYNTHESIZER SECTION

Fig. 12 represents a block diagram of the PLL section. The RZ-1 PLL uses two VCO's for frequencies below 60 MHz, and a CATV TV tuner for frequencies above 60MHz. Additionally four bands are obtained inside the tuner pack. The comparison frequencies are selected to correspond with the desired tuning step of 5kHz, 10kHz, 12.5kHz, 20kHz, 25kHz, 100kHz, 4MHz, and 6MHz (including Auto Step) as listed in Table 1. The 100kHz, 4MHz and 6MHz steps are referenced to a 25kHz reference and the 9kHz step to 3kHz.

The MB87006APF allows external selection of both the reference frequency-division ratio and the comparison frequency-division ratio via a serial data string. This IC has a modulus control function that is used to create a pulse swallow counter in conjunction with an external pre-scaler. The PLL IC is fed with a 12.6MHz signal from the reference oscillator circuit so that it may generate a comparison frequency at 5 different frequency division ratios corresponding to the various frequency step widths (Refer to Table 2).

The local oscillator signal from the tuner pack enters the pulse swallow counter after passing through wide band amplifier μ PC1651G. VCO signals below 60MHz pass

through buffer amplifier Q16 before entering the counter. In the counter the signals are frequency divided at a rate determined by the frequency-division ratio shown in the table 2, phase detected, and controlled by the resulting error correction voltage. To obtain a wide frequency coverage in the VCO the LPF is fed with +33V and -1.2V.

For example, at a dial frequency of 83MHz, the f_{vco} and the various frequency-division ratios have the following relationships :

$$f_{vco} = 83.00 + 45.75 = [n \times M + A] \times f_{osc} / R$$

where,

f_{vco} = Output frequency of the VCO

n = Set value of the binary 10 bit programmable counter

M = Set value of the dual modulus pre-scaler module to be connected to other circuits

$$460 > f : 64, 460 \leq f : 128$$

A = Set value of the binary 7 bit swallow counter

f_{osc} = Reference oscillator frequency, 12.6MHz

R = Set value of the binary 14 bit programmable counter, 504 for 25kHz (Refer to table 2)

In this example $n = 80$ and $A = 30$

$$\text{Therefore, } f_{vco} = [(80 \times 64) + 30] \times 12600 / 504 = 128.75\text{MHz.}$$

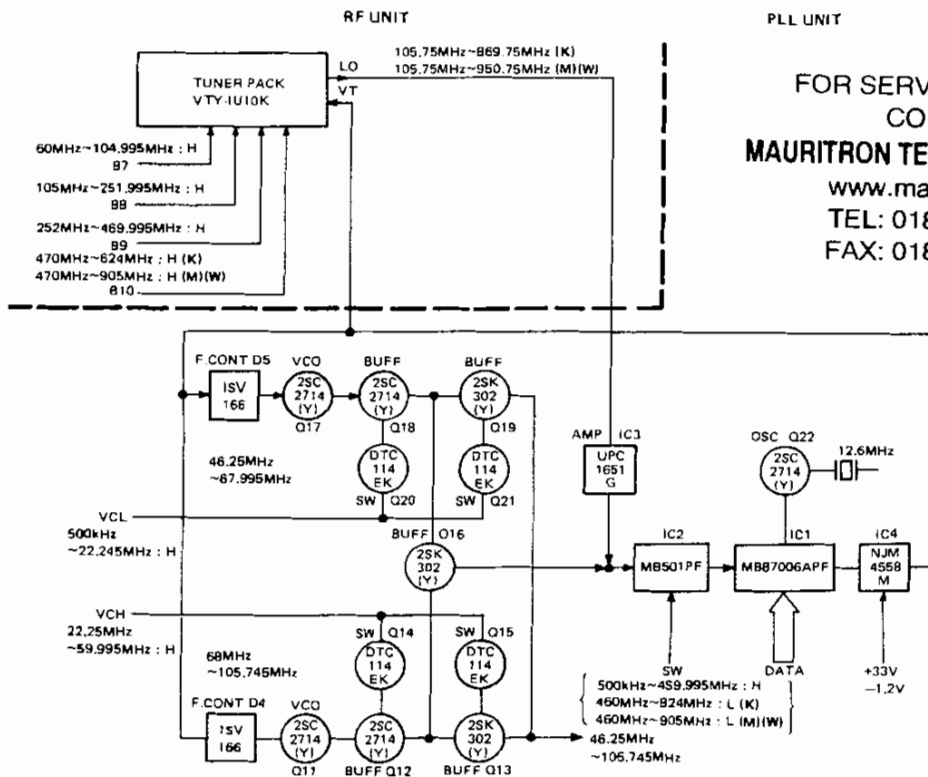

Fig. 12 PLL block diagram

FOR SERVICE MANUALS
CONTACT:
MAURITRON TECHNICAL SERVICES
www.mauritron.co.uk
TEL: 01844 - 351694
FAX: 01844 - 352554

CIRCUIT DESCRIPTION

Frequency (MHz)	$0.504 \leq f < 1.630$	$0.5 \leq f < 1.8$	$1.8 \leq f < 4.5$	$4.5 \leq f < 11$	$11 \leq f < 22.25$	$22.25 \leq f < 36$	$36 \leq f < 60$
Band information	B1	B1	B2	B3	B4	B5	B6
Pre-scaler SW	H	H	H	H	H	H	H
Pre-scaler ratio	64	64	64	64	64	64	64
VCO select	VCL	VCL	VCL	VCL	VCL	VCH	VCH
9kHz step ref. frequency	3kHz	/	/	/	/	/	/
5kHz step ref. frequency	+5kHz data 10kHz	←	←	←	←	←	←
12.5kHz step ref. frequency	6.25kHz	←	←	←	←	←	←
20kHz step ref. frequency	10kHz	←	←	←	←	←	←
25kHz step ref. frequency	+5kHz data 10kHz	←	←	←	←	←	←
5kHz SW	H : +5kHz	←	←	←	←	←	←
Frequency (MHz)	$80 \leq f < 105$	$105 \leq f < 252$	$252 \leq f < 460$	$460 \leq f < 470$	$470 \leq f \leq 905$ (M,W), 824 (K)		
Band information	B7	B8	B9	B9	B10		
Pre-scaler SW	H	H	H	L	L		
Pre-scaler ratio	64	64	64	128	128		
5kHz step ref. frequency	+5kHz data 10kHz	←	←	←	←		
12.5kHz step ref. frequency	±2.5kHz	←	←	←	←		
20kHz step ref. frequency	10kHz	←	←	←	←		
25kHz step ref. frequency	25kHz	←	←	←	←		
5kHz SW	H : +5kHz	←	←	←	←		

Table 1 Band data and PLL data

Ref. frequency	OSC div.
3kHz	4200
6.25kHz	2016
10kHz	1260
12.5kHz	1008
25kHz	504

Table 2 Ref. frequency and div. ratio

FOR SERVICE MANUALS
CONTACT:
MAURITRON TECHNICAL SERVICES
www.mauritron.co.uk
TEL: 01844 - 351694
FAX: 01844 - 352554

CIRCUIT DESCRIPTION

DIGITAL CONTROL SECTION

• General

The digital control section is composed of Control unit and a display section. All the functions is controlled by a single microprocessor.

The terminal functions of the microprocessor, IC1, IC3 and IC4 are shown in tables 3,4 and 5.

Terminal No.	Name	I/O	Logic	Function	Terminal No.	Name	I/O	Logic	Function
1	P62	O	L	Key scan output. KS2	37	P50	I	L	Key return input. KR0
2	P61	O	L	Key scan output. KS1	38	NC	-	-	Not connected.
3	P60	O	H	Key scan output. KS0	39	P17	O	-	Address bus. AB15
4	P47	O	L	LCD display inhibit. "L" : OFF	40	P16	O	-	Address bus. AB14
5	P46	O	-	Not used.	41	P15	O	-	Address bus. AB13
6	P45	O	H	LCD driver enable. EN1	42	P14	O	-	Address bus. AB12 (Not used.)
7	P44	O	H	LCD driver enable. EN2	43	P13	O	-	Address bus. AB11 (Not used.)
8	P43	I	-	Destination input.	44	P12	O	-	Address bus. AB10
9	P42	I	-		45	P11	O	-	Address bus. AB9
10	P41	I	-	Encoder input. ENC1	46	P10	O	-	Address bus. AB8
11	P40	I	-	Encoder input. ENC2	47	P07	O	-	Address bus. AB7
12	SRDY	-	-	Not used.	48	P06	O	-	Address bus. AB6
13	CLK	O	L	Serial clock output.	49	P05	O	-	Address bus. AB5
14	TXD	O	-	Serial data output.	50	P04	O	-	Address bus. AB4
15	RXD	I	-	Not used.	51	P03	O	-	Address bus. AB3
16	CNTR	O	-	Beep output.	52	P02	O	-	Address bus. AB2
17	INT2	I	-	Not used.	53	P01	O	-	Address bus. AB1
18	P30	O	-	Not used.	54	P00	O	-	Address bus. AB0
19	R/W	O	-	Read/Write signal output.	55	NC	-	-	Not connected.
20	INT1	I	-	Not used.	56	P27	I/O	-	Data bus. DB7
21	NC	-	-	Not connected.	57	P26	I/O	-	Data bus. DB6
22	NC	-	-	Not connected.	58	P25	I/O	-	Data bus. DB5
23	NC	-	-	Not connected.	59	P24	I/O	-	Data bus. DB4
24	CN Vss	I	-	Test terminal (Connect to GND.)	60	P23	I/O	-	Data bus. DB3
25	RESET	I	L	Reset input.	61	P22	I/O	-	Data bus. DB2
26	X IN	I	-	Ceramic oscillator connecting	62	P21	I/O	-	Data bus. DB1
27	X OUT	O	-	terminal.	63	P20	I/O	-	Data bus. DB0
28	φ	O	-	Timing output.	64	NC	-	-	Not connected.
29	Vss	-	-	GND terminal (0V).	65	Vss	-	-	GND terminal (0V).
30	P57	I	-	Not used.	66	NC	-	-	Not connected.
31	P56	I	-	Not used.	67	Vcc	-	-	Voltage supply terminal.
32	P55	I	L	DOWN key input.	68	P67	O	-	Not used.
33	P54	I	L	UP key input.	69	P66	O	-	Not used.
34	P53	I	L	Key return input. KR3	70	P65	O	L	Key scan output. KS5
35	P52	I	L	Key return input. KR2	71	P64	O	L	Key scan output. KS4
36	P51	I	L	Key return input. KR1	72	P63	O	L	Key scan output. KS3

Table 3 M50747-744-FP terminal function (Control unit IC1)

CIRCUIT DESCRIPTION

Terminal No.	Name	I/O	Logic	Function	Terminal No.	Name	I/O	Logic	Function
1	PA3	O	—	Pre-scaler switch, $f < 460\text{MHz}$: "H", $f \geq 60\text{MHz}$: "L"	20	PB2	O	H	Band information B3, $4.5 \leq f < 11$ (MHz)
2	PA2	O	H	PLL enable.	21	PB3	O	H	Band information B4, $11 \leq f < 22.25$ (MHz)
3	PA1	O	H	5kHz shift data, level "H" +5kHz shift by 10kHz ref.	22	PB4	O	H	Band information B5, $22.25 \leq f < 36$ (MHz)
4	PA0	O	H	Antenna switch for auto mode. AM and FM broadcasting : "L" (Car radio antenna)	23	PB5	O	H	Band information B6, $36 \leq f < 60$ (MHz)
5	RD	I	L	Read signal input.	24	PB6	O	H	Band information B7, $60 \leq f < 105$ (MHz)
6	CS	I	L	Chip select input.	25	PB7	O	H	Band information B8, $105 \leq f < 252$ (MHz)
7	GND	—	—	GND terminal.	26	Vcc	—	—	Voltage supply terminal.
8	A1	I	—	Address input A1.	27	D7	I/O	—	Data bus D7.
9	A0	I	—	Address input A0.	28	D6	I/O	—	Data bus D6.
10	PC7	I/O	H	Level "H" when less than 60MHz.	29	D5	I/O	—	Data bus D5.
11	PC6	I	—	Not used.	30	D4	I/O	—	Data bus D4.
12	PC5	I	—	Not used.	31	D3	I/O	—	Data bus D3.
13	PC4	I	—	Not used.	32	D2	I/O	—	Data bus D2.
14	PC0	O	—	Not used.	33	D1	I/O	—	Data bus D1.
15	PC1	O	—	Not used.	34	D0	I/O	—	Data bus D0.
16	PC2	O	H	Band information B10, $470 \leq f \leq 905$ or 824 (MHz)	35	RES	I	H	Reset input.
17	PC3	O	H	Band information B9, $252 \leq f < 460$, $460 \leq f < 470$ (MHz)	36	WR	I	L	Write signal input.
18	PB0	O	H	Band information B1, $0.504 \leq f < 1.630$, $0.5 \leq f < 1.8$ (MHz)	37	PA7	O	—	Not used.
19	PB1	O	H	Band information B2, $1.8 \leq f < 4.5$ (MHz)	38	PA6	O	—	Not used.
					39	PA5	O	—	Not used.
					40	PA4	O	—	Not used.

Table 4 M5M82C-55AFP-5 terminal function (Control unit IC3)

Terminal No.	Name	I/O	Logic	Function	Terminal No.	Name	I/O	Logic	Function
1	PA3	I	H	Not used.	21	PB3	O	H	MUTE output.
2	PA2	I	H	Stereo 1 display input.	22	PB4	O	H	Mode output FM-W.
3	PA1	I	H	BUSY input.	23	PB5	O	H	Mode output FM-N.
4	PA0	I	H	AF BUSY input.	24	PB6	O	—	Not used.
5	RD	I	L	Read signal input.	25	PB7	O	—	Not used.
6	CS	I	L	Chip select input.	26	Vcc	—	—	Voltage supply terminal.
7	GND	—	—	GND terminal.	27	D7	I/O	—	Data bus D7.
8	A1	I	—	Address input A1.	28	D6	I/O	—	Data bus D6.
9	A0	I	—	Address input A0.	29	D5	I/O	—	Data bus D5.
10	PC7	O	—	Not used.	30	D4	I/O	—	Data bus D4.
11	PC6	O	—	Not used.	31	D3	I/O	—	Data bus D3.
12	PC5	O	—	Not used.	32	D2	I/O	—	Data bus D2.
13	PC4	O	—	Not used.	33	D1	I/O	—	Data bus D1.
14	PC0	O	—	Not used.	34	D0	I/O	—	Data bus D0.
15	PC1	O	—	Not used.	35	RES	I	H	Reset input.
16	PC2	O	—	Not used.	36	WR	I	L	Write signal input.
17	PC3	O	H	AF circuit select output, TV band "H"	37	PA7	I	—	Not used.
18	PB0	O	—	Not used.	38	PA6	I	—	Not used.
19	PB1	O	H	Mode output AM.	39	PA5	I	H	Stereo 2 display input.
20	PB2	O	H	Mode output FM-W.	40	PA4	I	—	Not used.

Table 5 M5M82C-55AFP-5 terminal function (Control unit IC4)

CIRCUIT DESCRIPTION

Reset and Backup Circuits

Approximately 5.3V (5C) is supplied by voltage regulator IC8, and diode D1 when power is turned on. IC7 provides a "L" level from the time 5C rises until it reaches approximately 4.5V, but delivers a "H" level once the voltage exceeds 4.5V. This is used as a reset pulse. The pulse is designed so as to release the reset voltage only when the peripheral circuits have received a stabilized voltage. This is accomplished thru the used of a delay circuit composed of R7 and C35.

The pulse coming out of the time constant circuit is applied to the inverter of the schmitt trigger input, where it is shaped, simultaneously it becomes the reset signal for IC3, IC4 and IC1.

When power is turned off the 5C line starts to drop. When it has fallen below approximately 4.45V IC7 will send a logic "L". This forces the inverter input to become "L" causing the reset signal for IC3 and IC4 to become a source voltage, while the reset signal for IC1 assumes a "L" level in order to reset IC1.

The memory backup circuit backs up the RAM of IC2. When the reset pulse for IC1 becomes "L", $\overline{CE1}$ of IC2 goes "H" out to a control signal from Q1, thereby placing IC2 in a low power backup mode. This condition is maintained by a lithium battery. The backup current (current that flows out of the lithium battery) under normal conditions is approximately 0.012 μ A.

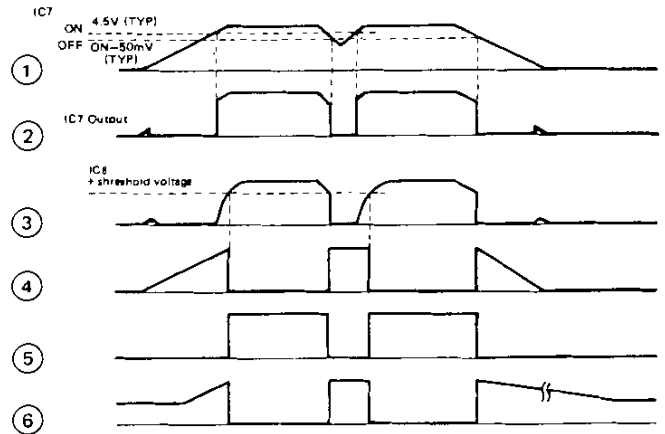
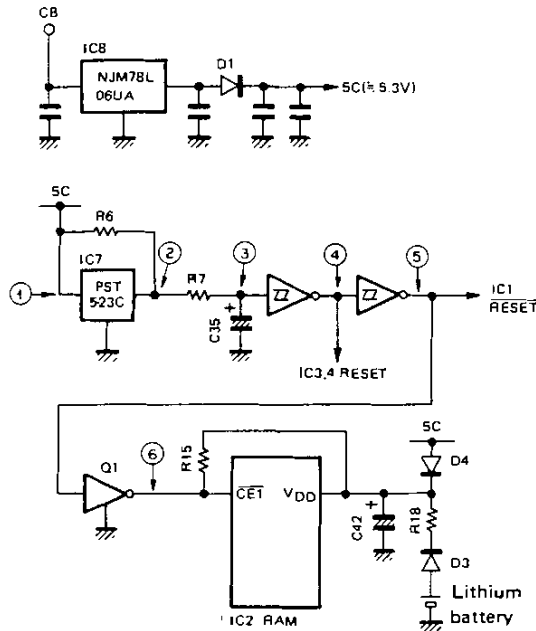
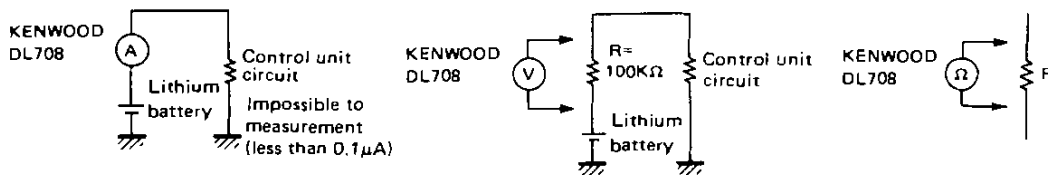

Fig. 13 Reset and backup circuits and timing chart



$$V_R = 1.2 \text{ [mV]}$$

$$R = 100.4 \text{ [k}\Omega\text{]}$$

$$I_{BU} = 1.2 \times 10^{-3} / 100.4 \times 10^3 = 1.2 \times 10^{-8} \text{ [A]}$$

Fig. 14 Measurement circuit of the backup current

FOR SERVICE MANUALS
CONTACT:
MAURITRON TECHNICAL SERVICES
www.mauritron.co.uk
TEL: 01844 - 351694
FAX: 01844 - 352554

CIRCUIT DESCRIPTION

● **Display Circuit**

The display circuit is contained on the display switch printed circuit board. It is composed of an LCD driver and its associated peripheral circuits and the LCD itself. The LCD lights using a 50% duty, dynamic lighting method, with the display contents, except those of the S-Meter circuit, transferred in a serial data format from the micro-processor to the LCD driver.

● **PLL Data Output and Band Information**

The CLK signal from the PLL is sent from the CLK of IC1, DAT from TXD of IC1 and EN from PA2 of IC3. Besides the PLL data, the unit switches the pre-scaler frequency-division ratio according to the selected dial frequency. (Refer to Table 2.)

Band information is delivered from PB0 to PB7, PC2 and PC3 of IC3. (Refer to Table 4.)

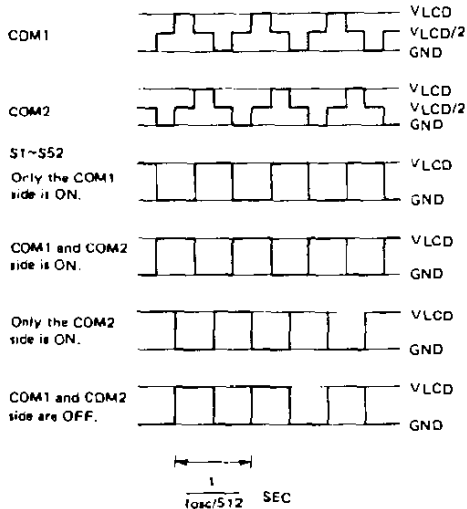

Fig. 15 LCD driver common and segment signals

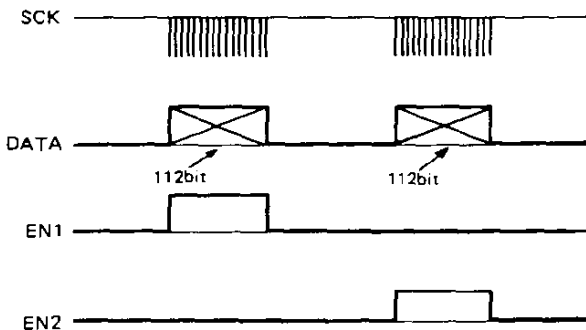

Fig. 16 Data transfer format

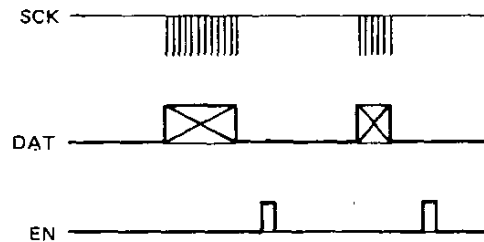

Fig. 18 Data transfer format

FOR SERVICE MANUALS
CONTACT:
MAURITRON TECHNICAL SERVICES
www.mauritron.co.uk
TEL: 01844 - 351694
FAX: 01844 - 352554

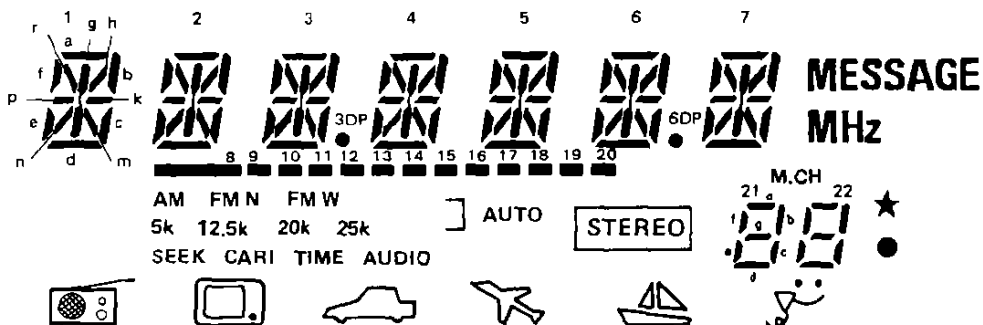

Fig. 17 LCD lighting conditions

CIRCUIT DESCRIPTION

• Key Input, Switches and Rotary Encoder

The keys located on the front panel are arranged in a key matrix consisting of lines P60 to P65 and P50 to P53, and the UP/DOWN keys. The signal from the rotary encoder passes through the inverter at the schmitt trigger input and enters lines P40 and P41.

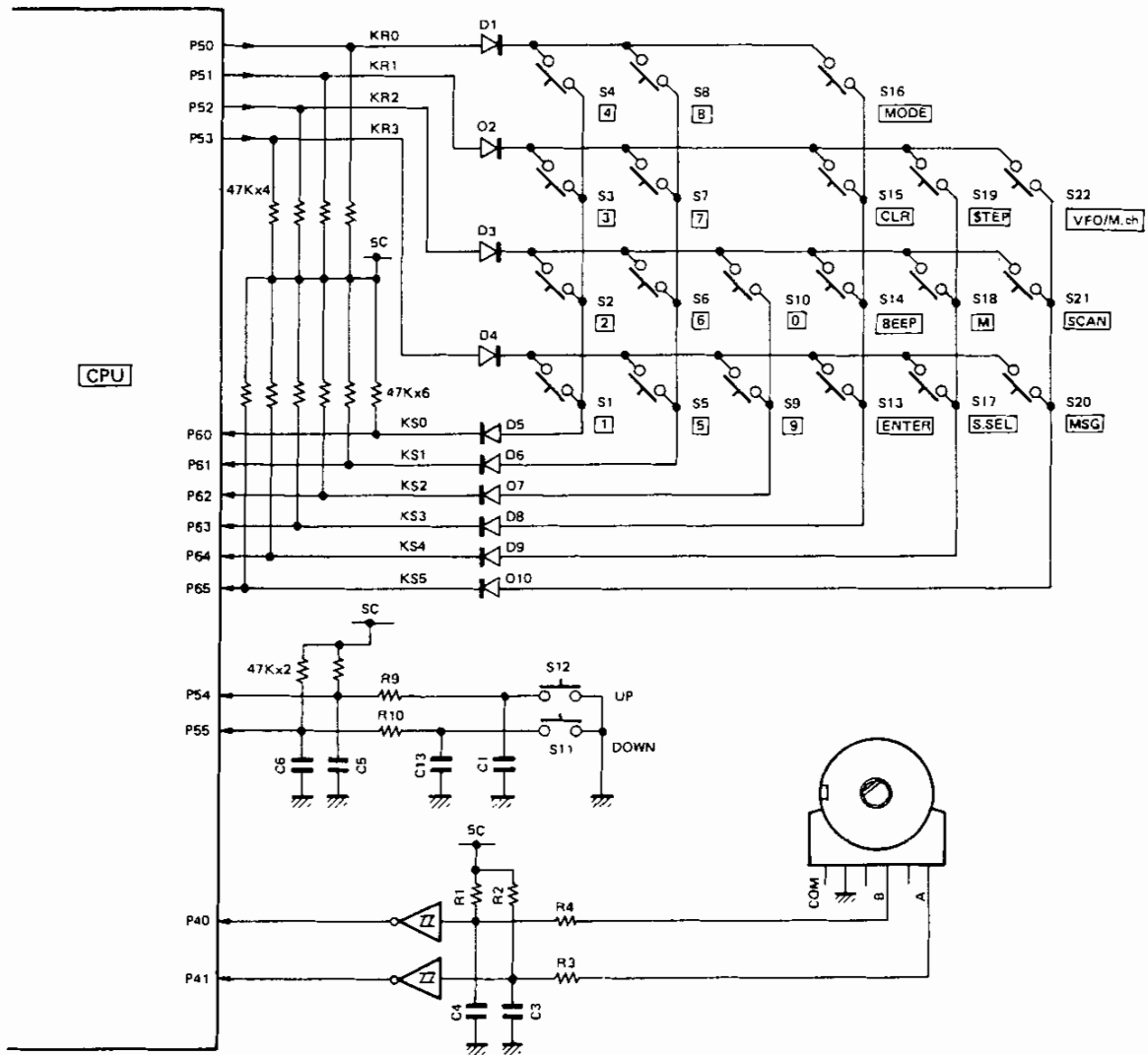

Fig. 19 Key, switch and rotary encoder input circuits

FOR SERVICE MANUALS
CONTACT:
MAURITRON TECHNICAL SERVICES
www.mauritron.co.uk
TEL: 01844 - 351694
FAX: 01844 - 352554

CIRCUIT DESCRIPTION/SEMICONDUCTOR DATA

● **Other Inputs and Outputs**

1) ST1

Inputs for stereo indicators. If a stereo signal is detected in the FM broadcast band, ST1 switches "H". This "H" signal causes the stereo indicator to turn on.

2) BUSY and AF BUSY

Inputs for indication of scan and BUSY. Both the scan and busy indicators operate when a "H" is applied. AF BUSY is applied only during Audio Scan in the FM-N mode.

3) FM-W, AM, FM-N and FM-W

Outputs for reception modes.

4) MUTE

Terminal for audio muting. The signal is muted when power is turned on for an external audio signal (pin jacks L/R), when frequency is changed, when the operating mode is changed, or when muting is activated by the C key.

5) BZ

Buzzer output. A square wave is generated by a divider in the microprocessor.

6) 5K

Provides 5kHz shift data for the PLL. This unit delivers 5kHz shift data even when the 5kHz step is selected because the PLL comparison reference frequency is 10kHz.

Shift	5K
0kHz	L
+5kHz	H

7) ANTC

Signal data terminal for antenna changeover. A "H" is provided in the AM broadcast band and in the FM broadcast band. This function is effective when the antenna changeover switch located on the back panel is placed in AUTO.

Band	Antenna
AM, FM	Antenna connector for car audio
Other	M type connector

LA1135M : AM tuner IC (IF unit IC4)

● **Block diagram**

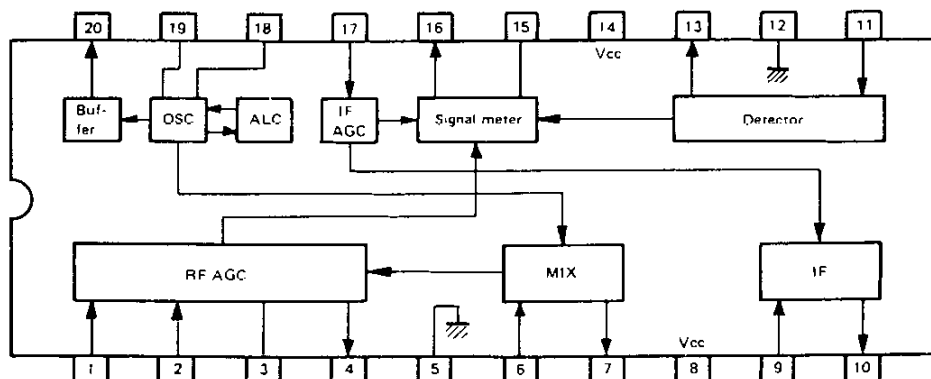

FOR SERVICE MANUALS
CONTACT:
MAURITRON TECHNICAL SERVICES
www.mauritron.co.uk
TEL: 01844 - 351694
FAX: 01844 - 352554

SEMICONDUCTOR DATA

LA1140 : FM-Wide 2nd IF amp. and detector (FM MPX IC1)

• Block diagram

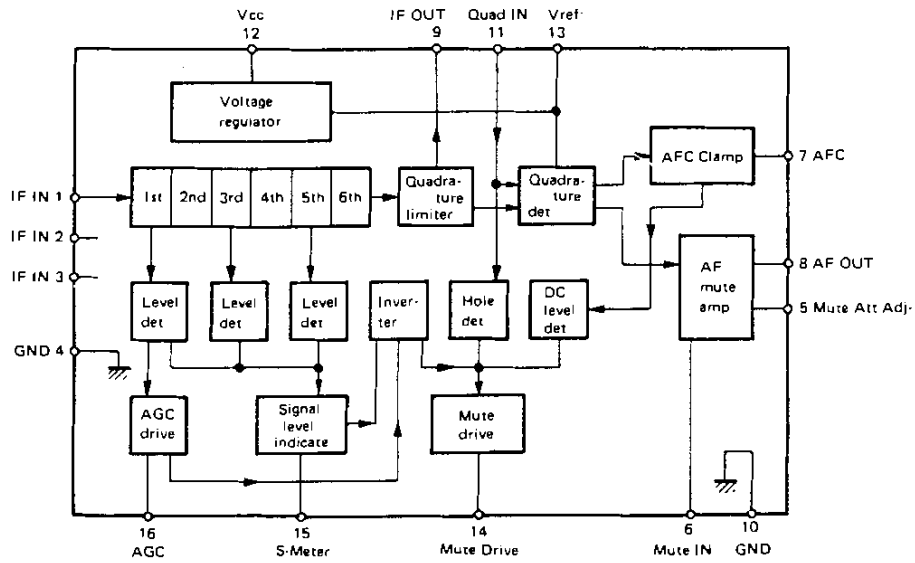

LA3430 : FM MPX demodulator (FM MPX IC3)

• Block diagram

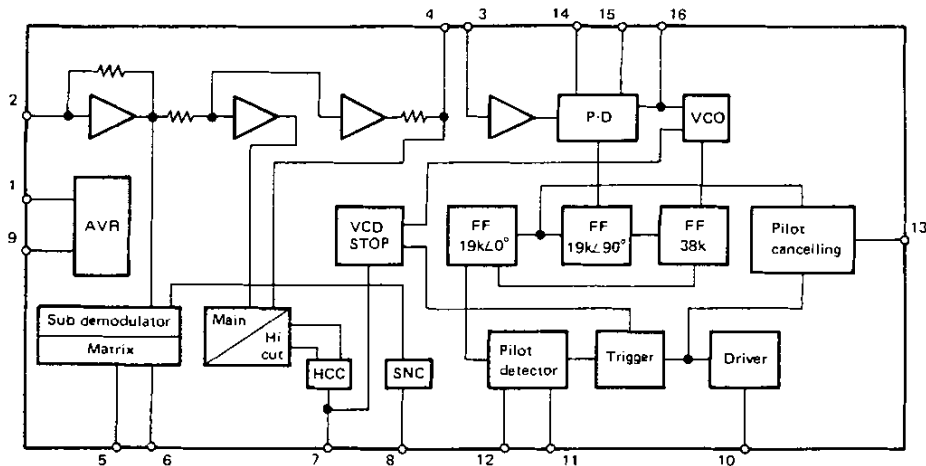

LA7505 : Video IF (IF unit IC3)

• Block diagram

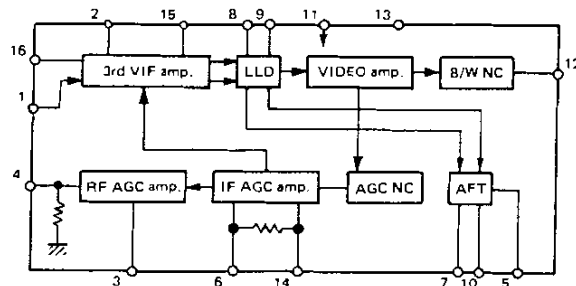

FOR SERVICE MANUALS
CONTACT:
MAURITRON TECHNICAL SERVICES
www.mauritron.co.uk
TEL: 01844 - 351694
FAX: 01844 - 352554

SEMICONDUCTOR DATA

FOR SERVICE MANUALS
CONTACT:
MAURITRON TECHNICAL SERVICES

KC-820A : Noise cancelling (FM MPX IC2)

• Block diagram

www.mauritron.co.uk
TEL: 01844 - 351694
FAX: 01844 - 352554

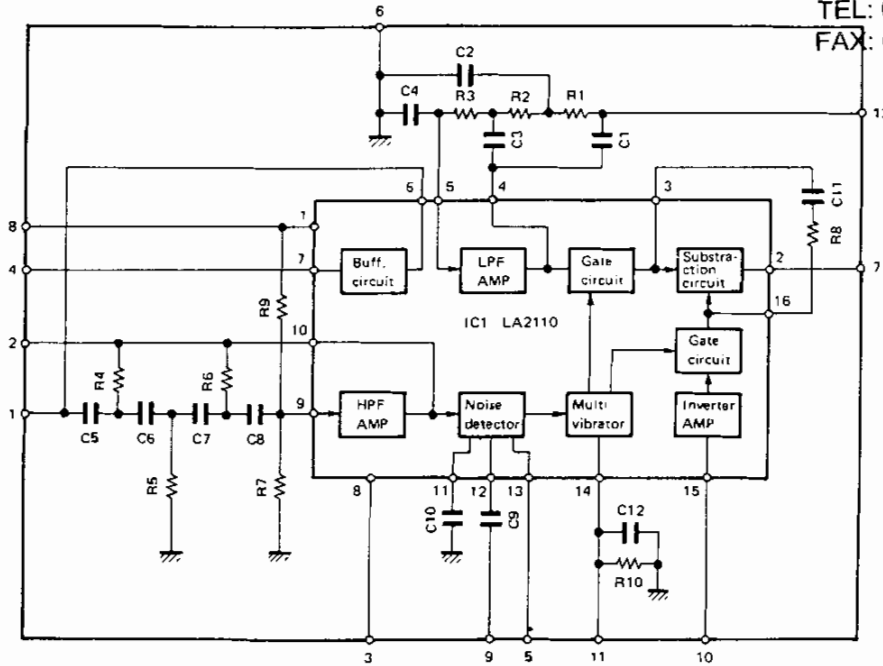

Tuner pack (W02-0807-05)

• Internal circuit

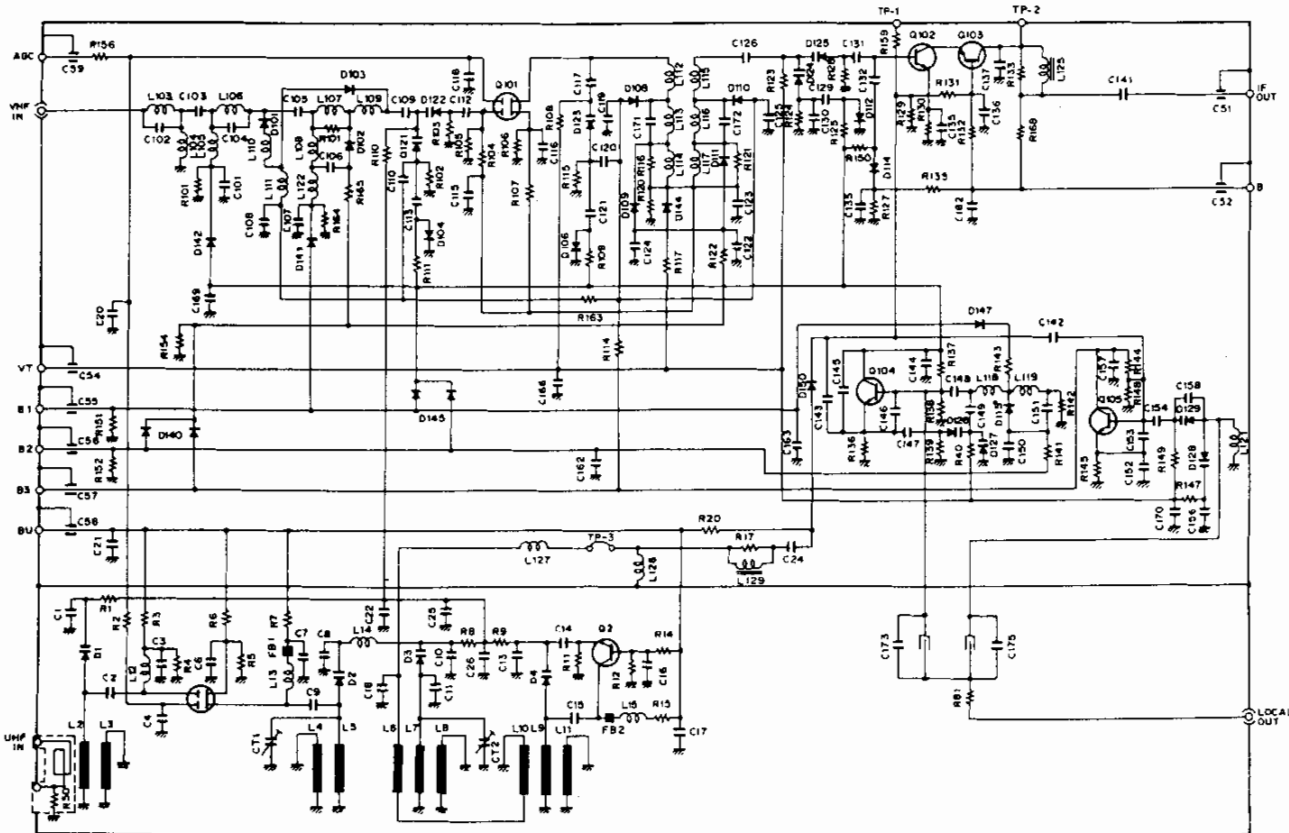

DESCRIPTION OF COMPONENTS

RF UNIT (X44-3050-00)

Component	Use/Function	Operation/Condition/Compatibility
IC1	8V AVR	
Q1 ~ 6	BPF SW	
Q7 ~ 10	Tuner pack band switch	
Q11 ~ 14	Switching for Q7 ~ 10	
Q15	Antenna select relay switch	
Q16	Ripple filter	

IF UNIT (X48-3040-XX)

Component	Use/Function	Operation/Condition/Compatibility
IC1	8V AVR	
IC2	AF amp.	
IC3	Video IF	Video IF amp., detector. K type only
IC4	AM tuner	Use to after mixing stage.
IC5	6V AVR	
Q1	RF amp.	FM-N 2nd IF amp.
Q3	AGC control	AGC voltage (AM).
Q4, 5	S-meter buffer	When AM mode.
Q6	S-meter switch	Adjust to VR3 (AM).
Q8	AF line switch	Turn on when FM-N and AM mode.
Q9 ~ 12	9V line switch	FMWB, FMNB, FMWB, AMB.
Q13 ~ 16	Switching for Q9 ~ 12	Mode switch.
Q22	Inside AF amp line SW	Inside amp. turn-off when connect the accessory connector plug to CN11 terminal.
Q23	Inverter for Q22 SW	BU : ON when +13.8V
Q24	RF amp.	FM-W 2nd IF amp.
Q25	RF amp.	Video 1st IF amp. K type only
Q26	Video output buffer	K type only
Q27	BUSY inverter	

PLL UNIT (X50-3070-00)

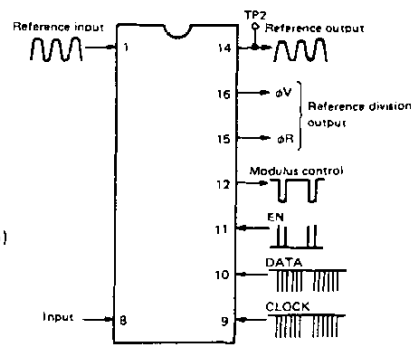
Component	Use/Function	Operation/Condition/Compatibility
IC1	PLL	<p>Pulse swallow counter circuit.</p> <ul style="list-style-type: none"> 1 : Reference input (12.8MHz), 450mVp-p. 8 : Input from pre-scaler (1/128). 9 : Clock input ; always present. 10 : Data input ; always present. 11 : Enable input ; 12 : Modulus control 5Vp-p. 14 : Reference output (Amplifier to pin 1 level in the IC 1.5Vp-p) 15 : Reference division output. 16 : Reference division output. 
IC2	Pre-scaler	1/64 : 460MHz > f, 1/128 : 460MHz ≤ f.
IC3	Wide-band Rf amp.	Amp. to VCO output from tuner pack.

DESCRIPTION OF COMPONENTS

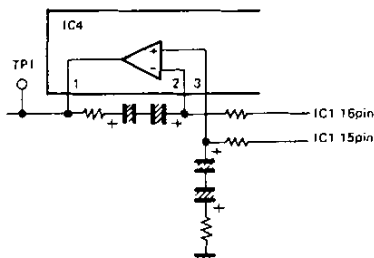
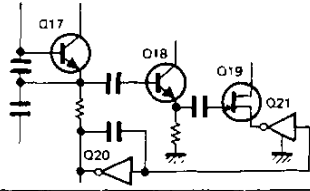
Component	Use/Function	Operation/Condition/Compatibility
IC4	PLL LPF	Operational amp. will operate within +30V, -1.2V for wide-band VCO. 
Q1	RF amp.	Amp. for less than 60MHz.
Q2	Buffer amp.	Less than 60MHz.
Q3	1st mixer	Less than 60MHz.
Q4	Buffer amp.	Less than 60MHz.
Q5	Buffer amp.	More than 60MHz.
Q6	2nd mixer	For FM-N mode.
Q7	5kHz shift switch	Level "H" when --5kHz.
Q8	2nd QSC	35.05MHz.
Q9	2nd OSC buffer	
Q10	2nd mixer	For FM-W mode.
Q11	VCO	Osc. for 68MHz ~ 105.75MHz.
Q12, 13	Buffer	
Q14, 15	VCO switch	VCH : Q11 will oscillating when level "H".
Q16	VCO output buffer	
Q17	VCO	46.25MHz ~ 68MHZ OSC. 
Q18, 19	Buffer	
Q20, 21	VCO switch	VCL : Q17 will oscillating when level "H".
Q22	PLL reference OSC.	12.6MHz
Q23	Q4 switch	Level "H" when frequency less than 60MHz.

CONTROL UNIT (X53-3110-XX)

Component	Use/Function	Operation/Condition/Compatibility
IC1	Microprocessor	Control the entire setting, mainly frequency control
IC2	Static RAM	VFO, memory data making
IC3	I/O port	Band information, PLL input/output.
IC4	I/O port	Mode control input/output.
IC5	Address decoder	RAM I/Q chip select, RD, WR making.
IC6	Schmitt trigger inverter	Encoder pulse wave shaping.
IC7	System reset	Reset signal output when the power switch turned on, low-voltage detection when the power switch turned off.
IC8	AVR	Input : 13.8V, Output : 6V.
Q1	RAM backup control	RAM will keep to backup condition when the power switch turned off. (Opened collector output)
D1	Diode for voltage dropping	5C (5V) making.
D2	Diode for voltage dropping	
D3	Current reversal prevention	From lithium battery.
D5	Zener diode	For VCO +33V.
D6	Sub diode of zener diode	For VCO - 1.4V.

FOR SERVICE MANUALS CONTACT:
MAURITRON TECHNICAL SERVICES
www.mauritron.co.uk
 TEL: 01844 - 351694
 FAX: 01844 - 352554

DESCRIPTION OF COMPONENTS

FM MPX (X58-3310-11)

Component	Use/Function	Operation/Condition/Compatibility
IC1	FM-W 2nd IF amp., Detector	
IC2	Noise cancelling	
IC3	FM MPX demodulator	
IC4	AF pre-amp.	
Q1	Audio signal buffer	
Q2	Sudio switch	FM-W mode : ON.
Q3, 4	Mute switch	
Q5, 6	S-meter buffer	
Q7	S-meter switch	Adjust with VR3.
Q8	BUSY switch	Adjust with VR4.
Q9	ANRC drive buffer	
Q10	Blend switch	Multi-pass occured : ON.
Q11	Stereo lamp inverter	
Q12, 13	Audio mute	

IF (X59-3140-00)

Component	Use/Function	Operation/Condition/Compatibility
IC1	2nd OSC, Mixer, IF amp. Quadrature detector, Noise amp.	7 : S-meter output. 11 : Noise amp. (1st stage) output. 9 : Detector output. 16 : 1st IF signal input.

SQL (X59-3150-00)

Component	Use/Function	Operation/Condition/Compatibility
Q1	Noise amp.	
Q2	Squelch switch	Squelch open : ON.
Q3, 4	DC amp.	Squelch closed : OFF.
Q5	AF amp.	
Q6	AF amp.	Squelch open : OFF.
D1	Squelch noise rectifier	
D2	Setting base bias	

SM (X59-3380-00)

Component	Use/Function	Operation/Condition/Compatibility
IC1	S-meter inverter amp., AF pre-amp.	
Q1	Switching	
Q2, 3	DC amp.	

FOR SERVICE MANUALS
CONTACT:
MAURITRON TECHNICAL SERVICES
www.mauritron.co.uk
TEL: 01844 - 351694
FAX: 01844 - 352554

PARTS LIST

CAPACITORS

CC 45 TH 1H 220 J
 1 2 3 4 5 6

CC45



Color*

Capacitor value

- 0 1 0 = 1pF
- 1 0 0 = 10pF
- 1 0 1 = 100pF
- 1 0 2 = 1000pF = 0.001μF

1 0 3 = 0.01μF

2 2 0 = 22pF
 1st number | Multiplier
 2nd number

- 1 = Type ceramic, electrolytic, etc.
- 2 = Shape round, square, etc.
- 3 = Temp. coefficient
- 4 = Voltage rating
- 5 = Value
- 6 = Tolerance

Temperature Coefficient

1st Word	C	L	P	R	S	T	U
Color*	Black	Red	Orange	Yellow	Green	Blue	Violet
ppm/°C	0	-80	-150	-220	-330	-470	-750

2nd Word	G	H	J	K	L
ppm/°C	± 30	± 60	± 120	± 250	± 500

Example CC45TH = -470 ± 60 ppm/°C

Tolerance

Code	C	D	G	J	K	M	X	Z	P	No code
(%)	± 0.25	± 0.5	± 2	± 5	± 10	± 20	+ 40 - 20	+ 80 - 20	+ 100 - 0	10μF-10~+50 4.7μF-10~+75

Code	B	C	D	F	G
(pF)	± 0.1	± 0.25	± 0.5	± 1	± 2

Less than 10 pF

Rating voltage

2nd word	A	B	C	D	E	F	G	H	J	K	V
0	1.0	1.25	1.6	2.0	2.5	3.15	4.0	5.0	6.3	8.0	-
1	10	12.5	16	20	25	31.5	40	50	63	80	35
2	100	125	160	200	250	315	400	500	630	800	-
3	1000	1250	1600	2000	2500	3150	4000	5000	6300	8000	-

Chip capacitors

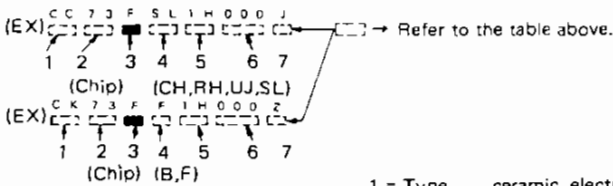

Dimension

Dimension code	L	W	T
Empty	5.6 ± 0.5	5.0 ± 0.5	Less than 2.0
E	3.2 ± 0.2	1.6 ± 0.2	Less than 1.25
F	2.0 ± 0.3	1.25 ± 0.2	Less than 1.25

Dimension

Dimension code	L	W	T	Wattage
E	3.2 ± 0.2	1.6 ± 0.2	0.57	2B
F	2.0 ± 0.3	1.25 ± 0.2	0.45	2A

Rating wattage

Cord	Wattage	Cord	Wattage	Cord	Wattage
2A	1/ 10W	2E	1/ 4W	3A	1W
2B	1/ 8W	2H	1/ 2W	3D	2W
2C	1/ 6W				

Dimension

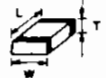

RESISTORS

Chip resistor (Carbon)

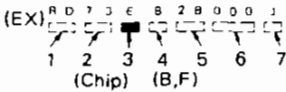

Carbon resistor (Normal type)

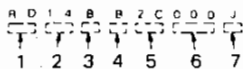

- 1 = Type ceramic, electrolytic, etc.
- 2 = Shape round, square, etc.
- 3 = Dimension
- 4 = Temp. coefficient
- 5 = Voltage rating
- 6 = Value
- 7 = Tolerance.

FOR SERVICE MANUALS
 CONTACT:

MAURITRON TECHNICAL SERVICES

www.mauritron.co.uk

TEL: 01844 - 351694

FAX: 01844 - 352554

PARTS LIST

✱ New Parts

Parts without Parts No. are not supplied.

Les articles non mentionnés dans le Parts No. ne sont pas fournis.

Telle ohne Parts No. werden nicht geliefert.

Ref. No. 参照番号	Address 位置	New Parts 新	Parts No. 部品番号	Description 部品名 / 規格	Desti- nation 仕向	Re- marks 備考
RZ-1						
1	1B	*	A01-1044-02	METALLIC CABINET(TOP)		
2	3B	*	A01-1043-02	METALLIC CABINET(BOTTOM)		
3	2B	*	A13-0680-12	FRAME		
4	2A	*	A20-2634-05	PANEL ASSY		
-			B42-2454-04	SERIAL LABEL		
6	3B	*	B40-3767-14	MODEL NAME PLATE	MW	
6	3B	*	B40-3768-14	MODEL NAME PLATE(WITH FCC LABEL)	K	
7	2B	*	B42-3327-04	LABEL (ATT ON-OFF)		
-			B46-0410-20	WARRANTY CARD	K	
-			B46-0419-00	WARRANTY CARD	W	
-		*	B50-8196-00	INSTRUCTION MANUAL		
		*	E31-3283-05	CONNECTING WIRE		
		*	E31-3284-05	CONNECTING WIRE		
		*	E31-3285-15	CONNECTING WIRE(BP,VBL-IF)		
		*	E31-3286-15	CONNECTING WIRE(2P,PLL-IF,200)		
		*	E31-3287-05	CONNECTING WIRE(2P,PLL-IF,130)		
		*	E31-3288-05	CONNECTING WIRE(2P-3P,PLL-IF)		
		*	E31-3290-05	RIBBON CABLE (CONT-RF)		
		*	E31-3336-05	CONNECTING WIRE(2P,SP)		
		*	E31-3366-05	CONNECTING WIRE(ACSY)		
		*	E40-5146-05	PIN CONNECTOR (6P)		
		*	E40-5147-05	PIN CONNECTOR (2P)		
14	2B	*	E30-0890-05	CORD WITH PLUG (A)		
16	1B	*	E30-2074-05	ANTENNA CONNECTING WIRE(UHF)		
17	1B	*	E30-2109-05	DC CORD		
19	2B	*	E31-3289-15	CONNECTING WIRE(10P,PLL-RF)		
20	2B	*	E23-0463-05	TERMINAL (GND)		
256	1E	*	E11-0430-05	PHONE JACK (3.5D)		
-			E30-2053-05	DC CORD ASSY (ACSY)		
			F05-1521-05	FUSE (1.5A) (ACSY)		
22	1B	*	F05-2036-05	FUSE (20A)		
23	3B	*	F19-0656-04	BLIND PLATE (REAR PANEL)		
24	2B	*	F19-0659-04	BLIND PLATE		
28	2A	*	G02-0574-04	FLAT SPRING (AVR IC)		
30	1A	*	G10-0651-04	FELT (SP)		
31	2A	*	G13-0889-04	CUSHION (PANEL)		
32	2A	*	G13-0890-04	CUSHION (LITHUM BATT)		
33	1B	*	G13-0896-04	FORMED PLATE		
34	2B,3B	*	G16-0521-04	FELT (TUNER PACK)		
211	1D	*	G09-0405-05	KNOB FITTING SPRING		
-		*	H01-8136-04	ITEM CARTON BOX		
-		*	H10-2636-02	POLYSTYRENE FOAMED FIXTURE		
-		*	H12-1345-14	POLYSTYRENE FOAMED PLATE		
-		*	H12-1407-04	PROTECTION PLATE		
-		*	H25-0060-03	PROTECTION BAG (350X400)		
-		*	H25-0103-04	PROTECTION BAG (125X250)		
		*	J02-0441-05	FOOT (ACSY)		
		*	J21-3437-04	MSUNTING HARDWARE (ACSY)		
47	2B	*	J19-1375-04	COAX. FITTING HARDWARE		
49	1A	*	J21-4204-14	MSUNTING HARDWARE (SP)		
50	2B	*	J21-4224-04	MSUNTING HARDWARE (CONVERTER)		

FOR SERVICE MANUALS
CONTACT:
MAURITRON TECHNICAL SERVICES
www.mauritron.co.uk
TEL: 01844 - 351694
FAX: 01844 - 352554

E: Scandinavia & Europe K: USA P: Canada W: Europe

U: PX(Far East, Hawaii) T: England M: Other Areas

UE: AAFES(Europe) X: Australia

⚠ indicates safety critical components.

PARTS LIST

× New Parts

Parts without Parts No. are not supplied.

Les articles non mentionnés dans le Parts No. ne sont pas fournis.

Teile ohne Parts No. werden nicht geliefert.

Ref. No. 参照番号	Address 位置	New Parts 新	Parts No. 部品番号	Description 部品名 / 規格	Desti- nation 仕向	Re- marks 備考
51	2B		J41-0033-05	CORD BUSHING (DC CORD TYPE.T		
52	2B		J42-0448-05	CORD BUSHING(ANT)		
215	2C	*	K29-3106-04	KNØB (MAIN)		
216	2C	*	K29-3107-04	KNØB (VØL,SQL)		
-		*	N99-0322-05	SCREW SET		
B	2B		N35-2006-46	BINDING HEAD MACHINE SCREW		
C	3A,3B		N87-2606-46	BRAZIER HEAD TAPTITE SCREW		
D	2B,3B		N35-2606-46	BINDING HEAD MACHINE SCREW		
E	2A		N32-2606-46	FLAT HEAD MACHINE SCREW		
F	3A,3B		N35-2606-45	BINDING HEAD MACHINE SCREW		
G	1A		N32-2606-45	FLAT HEAD MACHINE SCREW(SP)		
R101			RD14BB2C6Ø1J	RD 680 J 1/6W		
R102			RD14BB2C470J	RD 47 J 1/6W		
VR102	1D		RO5-4420-05	PØTENTIØMETER(SØKB)SQL		
S101	2B		S31-1407-05	SLIDE SWITCH		
SP101	1A	*	T90-0362-05	LEAD ANTENNA (ACS)		
			TØ7-0246-05	LØUDSPEAKER (FULLRANGE)		
IC1 .2			LC7582	IC(LCD DRIVER)		
VR101	1E	*	RO5-3444-05	PØTENTIØMETER(1ØKA)VØL		
			WØ2-0388-05	ROTARY ENCODER		
72	2A		WØ9-0359-05	LITHIUM BATTERY		
76	2B	*	X44-3Ø5Ø-ØØ	RF UNIT		
77	3B	*	X48-3Ø4Ø-11	IF UNIT		K
77	3B	*	X48-3Ø4Ø-21	IF UNIT		MW
78	1A	*	X5Ø-3Ø7Ø-ØØ	PLL UNIT		
79	2A	*	X53-311Ø-11	CØNTRØL UNIT		K
79	2A	*	X53-311Ø-21	CØNTRØL UNIT		M
79	2A	*	X53-311Ø-61	CØNTRØL UNIT		W
PANEL ASS'Y (A20-2634-05)						
201	2C	*	A20-2642-ØØ	PANEL		
205	2D	*	B11-Ø456-ØØ	LIGHT GUIDING PLATE		
206	2C	*	B1Ø-11Ø4-ØØ	FRONT GLASS		
2Ø8	2D		GØ1-Ø84Ø-ØØ	CØIL SPRING (STEP,M)		
2Ø9	2C		GØ1-Ø839-ØØ	CØIL SPRING (UP/DØWN)		
21Ø	2D		GØ1-Ø838-ØØ	CØIL SPRING (1-Ø)		
211	1D		GØ9-Ø4Ø5-Ø5	KNØB FITTING SPRING		
212	1E		G16-Ø522-ØØ	SHEET		
215	2C	*	K29-31Ø6-Ø4	KNØB (MAIN)		
216	2C	*	K29-31Ø7-Ø4	KNØB (VØL,SQL)		
217	1D	*	K29-3118-Ø8	KNØB (VØB/M. CH-SCAN)		
218	1D	*	K29-3119-Ø8	KNØB (MSG)		
219	2D	*	K29-312Ø-Ø8	KNØB (Ø)		
22Ø	2C	*	K29-3121-Ø8	KNØB (1)		
221	2C	*	K29-3122-Ø8	KNØB (2)		
222	2D	*	K29-3123-Ø8	KNØB (3)		
223	2D	*	K29-3124-Ø8	KNØB (4)		
224	2D	*	K29-3125-Ø8	KNØB (5)		
225	2D	*	K29-3126-Ø8	KNØB (6)		
226	2D	*	K29-3127-Ø8	KNØB (7)		

E: Scandinavia & Europe K: USA P: Canada W: Europe

U: PX(Far East, Hawaii) T: England M: Other Areas

UE: AAFES(Europe) X: Australia

▲ indicates safety critical components.

PARTS LIST

✱ New Parts

Parts without Parts No. are not supplied.

Les articles non mentionnés dans le Parts No. ne sont pas fournis.

Telle ohne Parts No. werden nicht geliefert.

Ref. No. 参照番号	Address 位置	New Parts 新	Parts No. 部品番号	Description 部品名/規格	Desti- nation 仕向	Re- marks 備考
227	2D	*	K29-3128-08	KNØB (8)		
228	2D	*	K29-3129-08	KNØB (9)		
229	2D	*	K29-3130-08	KNØB (STEP)		
230	2D	*	K29-3131-08	KNØB (M)		
231	2D	*	K29-3132-08	KNØB (S. SEL)		
232	2D	*	K29-3133-08	KNØB (MODE)		
233	2D	*	K29-3134-08	KNØB (C)		
234	2D	*	K29-3139-08	KNØB (BEEP)		
235	2D	*	K29-3136-08	KNØB (ENTER)		
236	2C	*	K29-3137-08	KNØB (UP)		
237	2C	*	K29-3138-08	KNØB (DOWN)		
H	1D, 2D		N89-1706-41	BIND TAP TITE SCREW		
J	1D, 2E		N30-2006-46	BIND SCREW		
K	2C		N32-2006-46	FLAT SCREW		
DISPLAY ASS'Y (W02-0811-08)						
-		*	B11-0454-08	LIGHT GUIDING PLATE		
-		*	B11-0455-08	FILTER		
-		*	B30-0859-08	PILØT LAMP		
256	1E	*	E11-0430-05	PHONE JACK (3.5D)		
-		*	E31-3283-05	LEAD WIRE CONNECTØR(12P)		
-		*	E31-3284-05	LEAD WIRE CONNECTØR(13P)		
-		*	E40-5146-05	PIN ASSY (6P)		
-		*	E40-5147-05	PIN ASSY (2P)		
264	1D	*	F19-0659-04	BLIND PLATE (MAIN KNØB)		
-		*	G13-0874-08	CUSHION		
-		*	G13-0875-08	CUSHION		
272	1E	*	J21-4227-08	HOLDER (LCD COVER)		
VR101	1E	*	R05-3444-05	PØTENTIØMETER(10KA) VØL		
VR102	1D	*	R05-4420-05	PØTENTIØMETER(50KB) SØL		
S1 -19		*	S40-1418-08	TACT SWITCH (1-0.UP/DØWN,ETC)		
S20 -22		*	S50-1426-05	TACT SWITCH (VØØ,SCAN,MSG)		
-		*	LU1367-1A	LCD		
IC1 ,2			LC7582	IC(LCD DRIVER)		
ENC1			W02-0388-05	RØTARY ENCODER		
RF UNIT (X44-3050-00)						
C1			CK73FB1H103K	CHIP C 0.010UF	K	
C2			CC41FSL1H121J	CYLND CHIP C 120PF	J	
C3			CC73FSL1H181J	CHIP C 180PF	J	
C4			CC41FSL1H151J	CYLND CHIP C 150PF	J	
C8 ,9			CK73FF1E104Z	CHIP C 0.10UF	Z	
C10			CC73FSL1H681J	CHIP C 680PF	J	
C11 ,12			CK41FY1E102M	CYLND CHIP C 1000PF	M	
C13 ,14			CK73FF1E104Z	CHIP C 0.10UF	Z	
C15			CC73FSL1H471J	CHIP C 470PF	J	
C16 ,17			CC73FSL1H681J	CHIP C 680PF	J	
C10			CK73FB1E223K	CHIP C 0.022UF	K	
C19			CK73FF1E473Z	CHIP C 0.047UF	Z	
C20			CC41FSL1H151J	CYLND CHIP C 150PF	J	
C21 ,22			CC73FSL1H391J	CHIP C 390PF	J	
C23			CK73FB1E223K	CHIP C 0.022UF	K	

FOR SERVICE MANUALS
 CONTACT:
MAURITRON TECHNICAL SERVICES
 www.mauritron.co.uk
 TEL: 01844 - 351694
 FAX: 01844 - 352554

E: Scandinavia & Europe K: USA P: Canada W: Europe

U: PX(Far East, Hawaii) T: England M: Other Areas

UE: AAFES(Europe) X: Australia

⚠ indicates safety critical components.

PARTS LIST

× New Parts

Parts without Parts No. are not supplied.

Les articles non mentionnés dans le Parts No. ne sont pas fournis.

Teile ohne Parts No. werden nicht geliefert.

Ref. No. 参照番号	Address 位 置	New Parts 新	Parts No. 部 品 番 号	Description 部 品 名 / 規 格	Desti- nation 仕 向	Re- marks 備 考
C24			CK73FF1E473Z	CHIP C 0.047UF Z		
C25			CC41FSL1H560J	CYLND CHIP C 56PF J		
C26 .27			CK73FSL1H331J	CHIP C 330PF J		
C28			CK73FB1E223K	CHIP C 0.022UF K		
C29			CK73FF1E473Z	CHIP C 0.047UF Z		
C30			CC41FSL1H390J	CYLND CHIP C 39PF J		
C31 .32			CC41FSL1H121J	CYLND CHIP C 120PF J		
C33 .34			CK73FB1E223K	CHIP C 0.022UF K		
C35 -41			CK41FY1E102M	CYLND CHIP C 1000PF M		
C42 .43			C92-0008-05	CHIP TAN 3.3UF 16WV		
C44			CK41FY1E102M	CYLND CHIP C 1000PF M		
C45			C92-0008-05	CHIP TAN 3.3UF 16WV		
C46			CK41FY1E102M	CYLND CHIP C 1000PF M		
C47			C92-0008-05	CHIP TAN 3.3UF 16WV		
C48 -51			CK41FY1E102M	CYLND CHIP C 1000PF M		
C52			C92-0008-05	CHIP TAN 3.3UF 16WV		
C53 .54			CK41FY1E102M	CYLND CHIP C 1000PF M		
C55			CK73FB1H102K	CHIP C 1000PF K		
C56 -66			CK41FY1E102M	CYLND CHIP C 1000PF M		
C67			CK73FB1H103K	CHIP C 0.010UF K		
C68			CE04EW1C470M	ELECTRN 47UF 16WV		
C69 -71			CK41FY1E102M	CYLND CHIP C 1000PF M		
C72 .73			CC41FCH1H020C	CYLND CHIP C 2.0PF C		
C74 .75			CK41FY1E102M	CYLND CHIP C 1000PF M		
C77 .78			CK73FF1E473Z	CHIP C 0.047UF Z		
C79			CC41FSL1H121J	CYLND CHIP C 120PF J		
C80			CC41FSL1H151J	CYLND CHIP C 150PF J		
C81			CE04EW1C470M	ELECTRN 47UF 16WV		
AT1 -4		*	E23-0611-05	TERMINAL		
EN1		*	E31-3293-05	LEAD WITH CONNECTOR(2P)		
EN2		*	E40-3563-05	PIN CONNECTOR (5533-12APB)		
EN3		*	E31-3294-05	LEAD WITH CONNECTOR(10P)		
W1		*	E31-3291-05	LEAD WITH CONNECTOR		
W2		*	E31-3292-05	LEAD WITH TERMINAL		
A1		*	F11-1075-04	SHIELDING COVER		
A2		*	F10-1377-14	SHIELDING PLATE		
L1			L33-0698-05	CHIP COIL (1MH)		
L2			L40-1082-48	SMALL FIXED INDUCTOR (0.18UH)		
L3			L40-2282-48	SMALL FIXED INDUCTOR (0.22UH)		
L4			L40-1582-48	SMALL FIXED INDUCTOR (0.15UH)		
L6		*	L33-0701-05	CHIP COIL (270UH)		
L8			L40-4792-48	SMALL FIXED INDUCTOR (4.7UH)		
L9 .10			L40-3392-48	SMALL FIXED INDUCTOR (3.3UH)		
L11			L40-1292-48	SMALL FIXED INDUCTOR (1.2UH)		
L12 .13			L40-8282-48	SMALL FIXED INDUCTOR (0.82UH)		
L14			L40-6882-48	SMALL FIXED INDUCTOR (0.68UH)		
L15 .16			L40-2782-48	SMALL FIXED INDUCTOR (0.27UH)		
L17			L40-5682-48	SMALL FIXED INDUCTOR (0.56UH)		
L18 .19			L40-1082-48	SMALL FIXED INDUCTOR (0.1UH)		
L20			L40-2782-48	SMALL FIXED INDUCTOR (0.27UH)		
L21 .22		*	L40-8272-48	SMALL FIXED INDUCTOR (0.82UH)		
L23			L33-0698-05	CHIP COIL (1MH)		
L24 -26			L40-4701-48	SMALL FIXED INDUCTOR (47UH)		

www.mauritron.co.uk
TEL: 01844 - 351694
FAX: 01844 - 352554

MAURITRON TECHNICAL SERVICES

CONTACT:

FOR SERVICE MANUALS

E: Scandinavia & Europe K: USA P: Canada W: Europe
U: PX(Far East, Hawaii) T: England M: Other Areas
UE: AAFES(Europe) X: Australia

⚠ indicates safety critical components.

PARTS LIST

* New Parts

Parts without Parts No. are not supplied.

Les articles non mentionnés dans le Parts No. ne sont pas fournis.

Teile ohne Parts No. werden nicht geliefert.

Ref. No. 参照番号	Address 位 置	New Parts 新	Parts No. 部 品 番 号	Description 部 品 名 / 規 格	Desti- nation 仕 向	Re- marks 備 考
R1			RD41FB2B471J	CYLND CHIP R 470 J 1/8W		
R2	.3		RD41FB2B223J	CYLND CHIP R 22K J 1/8W		
R4	-9		RD41FB2B471J	CYLND CHIP R 470 J 1/8W		
R10	.11		RD41FB2B102J	CYLND CHIP R 1.0K J 1/8W		
R21	-26		RD41FB2B222J	CYLND CHIP R 2.2K J 1/8W		
R27			RD41FB2B102J	CYLND CHIP R 1.0K J 1/8W		
R28			R92-0687-05	CHIP R 0.09HM		
R29			R92-0338-05	CYLND CHIP R 0.09HM		
K1			S51-1420-05	RELAY		
D1	-7	*	DAP236(K)	CHIP DIODE		
DB			DAN235(K)	CHIP DIODE		
D9	-15		DAN202(K)	CHIP DIODE		
D16			DAN235(K)	CHIP DIODE		
D17			DSP-301N	SURGE ABSORBER		
IC1		*	TA78L09F	IC(VOLTAGE REGULATOR/ +9V)		
Q1	-6		DT0114EK	DIGITAL TRANSISTOR		
Q7	-10	*	DTB123EK	DIGITAL TRANSISTOR		
Q11	-14		DT0114EK	DIGITAL TRANSISTOR		
Q15		*	DTD114EK	DIGITAL TRANSISTOR		
Q16			29C2712(Y)	TUNER PACK		
-		*	W02-0807-05	TUNER PACK (VTY-1U10K)		
IF UNIT (X48-3040-XX) -11 : K -21 : M, W						
C1			CC41FCH1H050C	CYLND CHIP C 5.0PF C		
C2			CC41FSL1H101J	CYLND CHIP C 100PF J		
C3	.4		CK73FB1H103K	CHIP C 0.010UF K		
C5			CK73FB1H102K	CHIP C 1000PF K		
C6			CC73FCH1H151J	CHIP C 150PF J		
C7			CC73FCH1H330J	CHIP C 33PF J		
C8			CK73FB1H103K	CHIP C 0.010UF K		
C9			CE04EW1C470M	ELECTRO 47UF 16WV		
C10			CK73FB1H103K	CHIP C 0.010UF K		
C11			CE04EW1C100M	ELECTRO 10UF 16WV		
C12			CE04EW1C470M	ELECTRO 47UF 16WV		
C13			CC41FSL1H101J	CYLND CHIP C 100PF J		
C14			CK73FB1H102K	CHIP C 1000PF K		
C15			CE04EW1C102M	ELECTRO 1000UF 16WV		
C16	.17		CK73FB1E223K	CHIP C 0.022UF K		
C18			CK73FB1E393K	CHIP C 0.039UF K		
C19			CK73FB1E333K	CHIP C 0.033UF K		
C20			CE04FW1HR47M	ELECTRO D. 47UF 50WV		
C21			CE04EW1H3R3M	ELECTRO 3.3UF 50WV		
C22			CE04EW1E4R7M	ELECTRO 4.7UF 25WV		
C23			CC41FCH1H050C	CYLND CHIP C 5.0PF C		
C24	.25		CE04EW1C100M	ELECTRO 10UF 16WV		
C26			CE04EW1C470M	ELECTRO 47UF 16WV		
C27			CK73FB1H103K	CHIP C 0.010UF K		
C28			CE04EW1C470M	ELECTRO 47UF 16WV		
C29			CK73FB1H103K	CHIP C 0.010UF K		
C30			CE04EW1C470M	ELECTRO 47UF 16WV		
C31	.32		CK73FB1H103K	CHIP C 0.010UF K		
C33			CE04EW1C470M	ELECTRO 47UF 16WV		
C34			CK73EF1C105Z	CHIP C 1.0UF Z		

E: Scandinavia & Europe K: USA P: Canada W: Europe

U: PX(Far East, Hawaii) T: England M: Other Areas

UE: AAFES(Europe) X: Australia

 indicates safety critical components.

PARTS LIST

* New Parts

Parts without Parts No. are not supplied.

Les articles non mentionnés dans le Parts No. ne sont pas fournis.

Tella ohne Parts No. werden nicht geliefert.

Ref. No. 参照番号	Address 位置	New Parts 新	Parts No. 部品番号	Description 部品名 / 規格	Desti- nation 仕 向	Re- marks 備考
C35			CE04EW1C100M	ELECTRO 10UF 16WV		
C36			CK73FB1H103K	CHIP C 0.010UF K		
C37 -39			CK73FB1E223K	CHIP C 0.022UF K		
C40 ,41			CK73FB1H102K	CHIP C 1000FF K	K	
C42			CC41FCH1H100D	CYLND CHIP C 10PF D	K	
C43 -45			CK73FB1H102K	CHIP C 1000FF K	K	
C46			CE04EW1H010M	ELECTRO 1.0UF 50WV	K	
C47			CE04EW1A101M	ELECTRO 100UF 10WV	K	
C48			CE04EW1C470M	ELECTRO 47UF 16WV	K	
C49			CK73FF1E473Z	CHIP C 0.047UF Z		
C50			CE04EW1H010M	ELECTRO 1.0UF 50WV		
C51			CK73FB1E393K	CHIP C 0.039UF K		
C52 ,53			CE04EW1C470M	ELECTRO 47UF 16WV		
C54 ,55			CK73FB1H102K	CHIP C 1000FF K		
C56			CE04EW1E221M	ELECTRO 220UF 25WV		
C57			CE04EW1C470M	ELECTRO 47UF 16WV		
C58			CO92M1H104K	MYLAR 0.10UF K		
C59			CE04EW1C222M	ELECTRO 2200UF 16WV		
C60			CK73FB1H103K	CHIP C 0.010UF K		
C61			CE04EW1C470M	ELECTRO 47UF 16WV		
C62			CK73FB1H103K	CHIP C 0.010UF K		
C63			CE04EW1HR47M	ELECTRO 0.47UF 50WV		
C64			CE04FW1HR47M	ELECTRO 0.47UF 50WV		
C65 -85			CK73FB1H103K	CHIP C 0.010UF K		
CN1 ,2		*	E40-5152-05	PIN CONNECTOR (SG0-11)		
CN3			E40-3243-05	PIN CONNECTOR (8P)		
CN4			E40-3237-05	PIN CONNECTOR (2P)		
CN5			E40-3237-05	PIN CONNECTOR (2P)	K	
CN6			E40-3237-05	PIN CONNECTOR (2P)		
CN7		*	E40-5156-05	PIN CONNECTOR (SB8P-HV0-5)		
CN8 ,9			E40-3237-05	PIN CONNECTOR (2P)		
CN11			E40-3243-05	PIN CONNECTOR (8P)		
J1 ,2		*	E13-0166-05	PIN JACK		
J3		*	E13-0166-05	PIN JACK	K	
J4			E11-0414-05	EXTERNAL SPEAKER JACK		
TP1			E23-U465-05	TERMINAL	K	
TP2 ,3		*	E23-0611-05	TERMINAL		
L1			L30-0005-05	IFT		
L2			L30-0531-05	IFT		
L3			L72-0315-05	CERAMIC FILTER (CFW455F)		
L4			L30-0503-05	IFT		
L5			L40-1011-14	SMALL FIXED INDUCTOR(100UH)		
L6		*	L34-4068-05	IFT (455KHZ)		
L7		*	L72-0364-05	CERAMIC FILTER (CFU455HT)		
L8		*	L30-0417-05	IFT		
L9		*	L72-0365-05	CERAMIC FILTER (BFU455C4N)		
L10			L72-0145-05	CERAMIC FILTER (SFE10.7MS2GH-A)		
L11		*	L30-0436-05	IFT		
L12 -14		*	L34-4069-05	IFT (45.75MHZ)	K	
L15			L40-1501-14	SMALL FIXED INDUCTOR(15UH)	K	
L16		*	L79-0819-05	FILTER (TPS4.5MC)	K	
L17		*	L15-0309-05	LOW-FREQUENCY CHOKE COIL(1.5MH)		
X1			L77-0946-15	CRYSTAL RESONATOR(10.245MHZ)		
XF1			L71-0228-05	MCF (10.7MHZ)		

FOR SERVICE MANUALS
 CONTACT:
MAURITRON TECHNICAL SERVICES
 www.mauritron.co.uk
 TEL: 01844 - 351694
 FAX: 01844 - 352554

E: Scandinavia & Europe K: USA P: Canada W: Europe
 U: PX(Far East, Hawaii) T: England M: Other Areas
 UE: AAFES(Europe) X: Australia

▲ indicates safety critical components.

PARTS LIST

× New Parts

Parts without Parts No. are not supplied.

Les articles non mentionnés dans le Parts No. ne sont pas fournis.

Telle ohne Parts No. werden nicht geliefert.

Ref. No. 参照番号	Address 位置	New Parts 新	Parts No. 部品番号	Description 部品名 / 規格	Desti- nation 仕向	Re- marks 備考
J5			R92-1061-05	JUMPER REST 0 0HM	MW	
R1			RD41FB2B182J	CYLND CHIP R 1.0K J 1/0W		
R2			RD41FB2B472J	CYLND CHIP R 4.7K J 1/0W		
R3			RD41FB2B103J	CYLND CHIP R 10K J 1/0W		
R4			RD41FB2B473J	CYLND CHIP R 47K J 1/0W		
R5			RD41FB2B471J	CYLND CHIP R 470 J 1/0W		
R6	.7		RD41FB2B101J	CYLND CHIP R 100 J 1/0W		
R8			RD41FB2B182J	CYLND CHIP R 1.0K J 1/0W		
R9			RD41FB2B473J	CYLND CHIP R 47K J 1/0W		
R10			RD41FB2B333J	CYLND CHIP R 33K J 1/0W		
R11			R92-0607-05	CHIP R 0 0HM		
R12			RD41FB2B473J	CYLND CHIP R 47K J 1/0W		
R12			R92-0607-05	CHIP R 0 0HM		
R13			RD41FB2B102J	CYLND CHIP R 1.0K J 1/0W		
R14			R92-0607-05	CHIP R 0 0HM		
R15			RD41FB2B473J	CYLND CHIP R 47K J 1/0W		
R16			RD41FB2B101J	CYLND CHIP R 100 J 1/0W		
R17			RD41FB2B222J	CYLND CHIP R 2.2K J 1/0W		
R18			R92-0607-05	CHIP R 0 0HM		
R19			RD41FB2B101J	CYLND CHIP R 100 J 1/0W		
R20			R92-0338-05	CYLND CHIP R 0 0HM		
R21			RD41FB2B123J	CYLND CHIP R 12K J 1/0W		
R22			RD41FB2B680J	CYLND CHIP R 68 J 1/0W		
R23	.24		RD41FB2B103J	CYLND CHIP R 10K J 1/0W		
R25			RD41FB2B223J	CYLND CHIP R 22K J 1/0W		
R26	.27		RD41FB2B103J	CYLND CHIP R 10K J 1/0W		
R28			RD41FB2B104J	CYLND CHIP R 100K J 1/0W		
R29	.31		RD41FB2B103J	CYLND CHIP R 10K J 1/0W		
R32			RD41FB2B473J	CYLND CHIP R 47K J 1/0W		
R33			RD41FB2B103J	CYLND CHIP R 10K J 1/0W		
R34			RD41FB2B104J	CYLND CHIP R 100K J 1/0W		
R35			RD41FB2B473J	CYLND CHIP R 47K J 1/0W		
R36			RD41FB2B105J	CYLND CHIP R 1.0M J 1/0W		
R37	.44		RD41FB2B472J	CYLND CHIP R 4.7K J 1/0W		
R40			RD41FB2B182J	CYLND CHIP R 1.0K J 1/0W		
R49			RD41FB2B103J	CYLND CHIP R 10K J 1/0W		
R50			RD41FB2B102J	CYLND CHIP R 1.0K J 1/0W		
R51			RD41FB2B331J	CYLND CHIP R 330 J 1/0W		
R52			RD41FB2B682J	CYLND CHIP R 6.8K J 1/0W		
R53			R92-0607-05	CHIP R 0 0HM		
R54			RD41FB2B101J	CYLND CHIP R 100 J 1/0W		
R55			RD41FB2B222J	CYLND CHIP R 2.2K J 1/0W		
R56			RD41FB2B474J	CYLND CHIP R 470K J 1/0W		K
R57	.58		RD41FB2B101J	CYLND CHIP R 100 J 1/0W		K
R59			RD41FB2B222J	CYLND CHIP R 2.2K J 1/0W		K
R60			RD41FB2B563J	CYLND CHIP R 56K J 1/0W		
R61			RD41FB2B473J	CYLND CHIP R 47K J 1/0W		K
R61			RD41FB2B822J	CYLND CHIP R 8.2K J 1/0W		MW
R62			RD41FB2B332J	CYLND CHIP R 3.3K J 1/0W		K
R63			RD41FB2B271J	CYLND CHIP R 270 J 1/0W		K
R64			R92-0607-05	CHIP R 0 0HM		K
R65			RD41FB2B101J	CYLND CHIP R 100 J 1/0W		K
R66			RD41FB2B122J	CYLND CHIP R 1.2K J 1/0W		K
R67			RD41FB2B681J	CYLND CHIP R 680 J 1/0W		
R68			RD41FB2B151J	CYLND CHIP R 150 J 1/0W		

E: Scandinavia & Europe K: USA P: Canada W: Europe

U: PX(Far East, Hawaii) T: England M: Other Areas

UE: AAFES(Europe) X: Australia

⚠ indicates safety critical components.

PARTS LIST

* New Parts

Parts without Parts No. are not supplied.

Les articles non mentionnés dans le Parts No. ne sont pas fournis.

Teile ohne Parts No. werden nicht geliefert.

Ref. No. 参照番号	Address 位置	New Parts 新	Parts No. 部品番号	Description 部品名 / 規格	Desti- nation 仕向	Re- marks 備考
R69			RD41FB2B2R2J	CYLND CHIP R 2.2 J 1/8W		
R70			RD41FB2B224J	CYLND CHIP R 220K J 1/8W		
R71			R92-0338-05	CYLND CHIP R 0 8HM		
R72			RD41FB2B473J	CYLND CHIP R 47K J 1/8W		
R73			RD41FB2B105J	CYLND CHIP R 1.0M J 1/8W		
R74 .75			RD41FB2B472J	CYLND CHIP R 4.7K J 1/8W		
R76 .77			R92-0687-05	CHIP R 0 8HM		
R79 .80			R92-0338-05	CYLND CHIP R 0 8HM		
R81			R92-0687-05	CHIP R 0 8HM		
R85			RD14BB2C473J	RD 47K J 1/8W		
VR1			R12-5047-05	TRIMMING PNT. (220K)		
VR3			R12-3099-05	TRIMMING PNT. (47K)		
VR4			R12-3096-05	TRIMMING PNT. (10K)		
VR5			R12-3096-05	TRIMMING PNT. (10K)		
S1		*	S31-1421-05	SLIDE SWITCH		
D1			RLS73	CHIP DIODE		
D2		*	DSM1A1	DIODE		
D3			RLS73	CHIP DIODE		
D4			1SS226	CHIP DIODE		
D5 -7			RLS73	DIODE		
D12			RLS73	CHIP DIODE		
D14 -17			RLS73	CHIP DIODE		
IC1			MC7808C	IC(VOLTAGE REGULATOR/ +14V)		
IC2			UPC1242H	IC(AF POWER AMP)		
IC3		*	LA7505	IC(TV P IF)	X	
IC4		*	LA1135M	IC(AM)		
IC5		*	NJM78L05UA	IC(VOLTAGE REGULATOR/ +5V)		
Q1			2SC2714(Y)	CHIP TRANSISTOR		
Q3			2SC2712(Y)	CHIP TRANSISTOR		
Q4			2SA1162(Y)	CHIP TRANSISTOR		
Q5 .6			2SC2712(Y)	CHIP TRANSISTOR		
Q8			2SK208(Y)	CHIP FET		
Q9 -12			2SB698	TRANSISTOR		
Q13 -16			DTC144EK	DIGITAL TRANSISTOR		
Q22			2SK208(Y)	CHIP FET		
Q23			DTC144EK	DIGITAL TRANSISTOR		
Q24			2SC2714(Y)	CHIP TRANSISTOR		
Q25			2SC2714(Y)	CHIP TRANSISTOR		
Q26			2SC1959(Y)	TRANSISTOR	K	
Q27			DTC144EK	DIGITAL TRANSISTOR	K	
TH1			112-502-2	THERMISTOR (5K)		
91	3B	*	X58-3310-11	SUB UNIT (FM MPX)		
95	2B	*	X59-3140-00	MODULE UNIT (SQL)		
96	3A	*	X59-3150-00	MODULE UNIT (IF)		
97	2A	*	X59-3380-00	MODULE UNIT (SM)		
PLL UNIT (X50-3070-00)						
C1 -3			CK41FF1C103Z	CYLND CHIP C 0.010UF Z		
C4 .5			CK73FF1E473Z	CHIP C 0.047UF Z		
C6			CC41FSL1H101J	CYLND CHIP C 100PF J		
C7			CK73FF1E473Z	CHIP C 0.047UF Z		
C8			CK41FF1C103Z	CYLND CHIP C 0.010UF Z		
C9			CC41FSL1H101J	CYLND CHIP C 100PF J		
C10 .11			CC41FCH1H100D	CYLND CHIP C 10PF D		

FOR SERVICE MANUALS
 CONTACT:
MAURITRON TECHNICAL SERVICES
 www.mauritron.co.uk
 TEL: 01844 - 351694
 FAX: 01844 - 352554

E: Scandinavia & Europe K: USA P: Canada W: Europe

U: PX(Far East, Hawaii) T: England M: Other Areas

UE: AAFES(Europe) X: Australia

▲ indicates safety critical components.

PARTS LIST

* New Parts

Parts without Parts No. are not supplied.

Les articles non mentionnés dans le Parts No. ne sont pas fournis.

Teile ohne Parts No. werden nicht geliefert.

Ref. No. 参照番号	Address 位置	New Parts 新	Parts No. 部品番号	Description 部品名 / 規格	Desti- nation 仕向	Re- marks 備考
C12			CC73FCH1H330J	CHIP C 33PF J		
C13	.14		CK41FF1C103Z	CYLND CHIP C 0.010UF Z		
C15			CK41FY1E102M	CYLND CHIP C 1000PF M		
C16			CC41FSL1H470J	CYLND CHIP C 47PF J		
C17			CK41FY1E102M	CYLND CHIP C 1000PF M		
C18			CC41FSL1H470J	CYLND CHIP C 47PF J		
C19			CK41FY1E102M	CYLND CHIP C 1000PF M		
C20			CC41FCH1H220J	CYLND CHIP C 22PF J		
C23	.24		CK41FY1E102M	CYLND CHIP C 1000PF M		
C25			CC41FSL1H470J	CYLND CHIP C 47PF J		
C26	.27		CK41FY1E102M	CYLND CHIP C 1000PF M		
C29			CC41FCH1H030C	CYLND CHIP C 3.0PF C		
C30			CC41FRH1H100D	CYLND CHIP C 10PF D		
C31			CC73FCH1H121J	CHIP C 120PF J		
C32			CC73FCH1H680J	CHIP C 68PF J		
C33			CK41FY1E102M	CYLND CHIP C 1000PF M		
C34			CC73FCH1H121J	CHIP C 120PF J		
C35			CK41FY1E102M	CYLND CHIP C 1000PF M		
C36	.37		CC41FSL1H101J	CYLND CHIP C 100PF J		
C38			CK41FY1E102M	CYLND CHIP C 1000PF M		
C39			CC41FCH1H100D	CYLND CHIP C 10PF D		
C40			CC41FCH1H060D	CYLND CHIP C 6.0PF D		
C41			CC73FCH1H330J	CHIP C 33PF J		
C42	-44		CK41FY1E102M	CYLND CHIP C 1000PF M		
C45			CC73FCH1H820J	CHIP C 82PF J		
C46			CC41FCH1H220J	CYLND CHIP C 22PF J		
C47			CC41FCH1H100D	CYLND CHIP C 10PF D		
C48	.49		CK41FY1E102M	CYLND CHIP C 1000PF M		
C50			CC41FCH1H100D	CYLND CHIP C 10PF D		
C51			CK73FF1E473Z	CHIP C 0.047UF Z		
C52			CK41FY1E102M	CYLND CHIP C 1000PF M		
C53			CC41FCH1H100D	CYLND CHIP C 10PF D		
C54			CK41FY1E102M	CYLND CHIP C 1000PF M		
C56			CK73FF1E473Z	CHIP C 0.047UF Z		
C57			CC41FCH1H100D	CYLND CHIP C 10PF D		
C58			C91-1020-05	CHIP C 0.1UF Z		
C59			CC41FCH1H100D	CYLND CHIP C 10PF D		
C60			CC73FCH1H820J	CHIP C 82PF J		
C61			CC41FCH1H220J	CYLND CHIP C 22PF J		
C62			CC41FCH1H100D	CYLND CHIP C 10PF D		
C63	-65		CK41FY1E102M	CYLND CHIP C 1000PF M		
C66			CC41FCH1H100D	CYLND CHIP C 10PF D		
C67			CK73FF1E473Z	CHIP C 0.047UF Z		
C68	.69		CC41FCH1H100D	CYLND CHIP C 10PF D		
C70			CK41FY1E102M	CYLND CHIP C 1000PF M		
C71			CE04EW1A470M	ELECTR8 47UF 10WV		
C72			CK73FF1E473Z	CHIP C 0.047UF Z		
C73	.74		CS15E1V1R5M	TANTAL 1.5UF 35WV		
C75			CE04EW1H220M	ELECTR8 22UF 50WV		
C76			CK73FB1H102K	CHIP C 1000PF K		
C77	.78		CS15E1V1R5M	TANTAL 1.5UF 35WV		
C79	-81		CK41FY1E102M	CYLND CHIP C 1000PF M		
C83	-85		CK41FY1E102M	CYLND CHIP C 1000PF M		
C86			CE04EW1A470M	ELECTR8 47UF 10WV		
C87	-89		CK41FY1E102M	CYLND CHIP C 1000PF M		

E: Scandinavia & Europe K: USA P: Canada W: Europe

U: PX(Far East, Hawaii) T: England M: Other Areas

UE: AAFES(Europe) X: Australia

 indicates safety critical components.

PARTS LIST

* New Parts

Parts without Parts No. are not supplied.

Les articles non mentionnés dans le Parts No. ne sont pas fournis.

Teile ohne Parts No. werden nicht geliefert.

Ref. No. 参照番号	Address 位置	New Parts 新	Parts No. 部品番号	Description 部品名 / 規格	Desti- nation 仕向	Re- marks 備考
C91			CK41FY1E102M	CYLND CHIP C 1000PF M		
C92			CC41FRH1H130J	CYLND CHIP C 13PF J		
C93			CC73FCH1H221J	CHIP C 220PF J		
C94			CC73FCH1H121J	CHIP C 120PF J		
C95			CK41FY1E102M	CYLND CHIP C 1000PF M		
C97			CK41FY1E102M	CYLND CHIP C 1000PF M		
C98			CK73FB1H102K	CHIP C 1000PF K		
C99 -108			CK41FY1E102M	CYLND CHIP C 1000PF M		
C109,110			CK73FB1H102K	CHIP C 1000PF K		
C111			CK41FY1E102M	CYLND CHIP C 1000PF M		
C112			CK73FB1H102K	CHIP C 1000PF K		
C113,114			CK41FY1E102M	CYLND CHIP C 1000PF M		
C115			CC41FSL1H101J	CYLND CHIP C 100PF J		
C116			CK41FY1E102M	CYLND CHIP C 1000PF M		
C117			CC41FSL1H101J	CYLND CHIP C 100PF J		
C118			CC41FSL1H470J	CYLND CHIP C 47PF J		
C119			CK41FF1C103Z	CYLND CHIP C 0.010UF Z		
C120-123			CK41FY1E102M	CYLND CHIP C 1000PF M		
TC1			C05-0356-05	TRIMMING CAP (20P)		
TC2			C05-0346-05	TRIMMING CAP (6P)		
CN1			E40-5067-05	PIN CONNECTOR (10P)		
CN2		*	E40-5153-05	PIN CONNECTOR (8P)		
CN3			E40-3237-05	PIN CONNECTOR (2P)		
CN4			E40-3238-05	PIN CONNECTOR (3P)		
CN5			E40-5033-05	FPC CONNECTOR		
CN6			E40-3237-05	PIN CONNECTOR (2P)		
TP1 -3			E23-0465-05	TERMINAL		
TP4 .5			E23-0512-05	TERMINAL		
-			J30-0545-05	SPACER		
L1			L40-1525-04	SMALL FIXED INDUCTOR(1.5MH)		
L2		*	L33-0708-05	SMALL FIXED INDUCTOR(470UH)		
L3			L40-2292-48	SMALL FIXED INDUCTOR(2.2UH)		
L4			L40-1092-48	SMALL FIXED INDUCTOR(1UH)		
L5		*	L33-0709-05	SMALL FIXED INDUCTOR(820UH)		
L6			L40-1011-48	SMALL FIXED INDUCTOR(100UH)		
L7		*	L34-4062-05	COIL (VCOH)		
L8 .9			L40-1011-48	SMALL FIXED INDUCTOR(100UH)		
L10		*	L34-4061-05	COIL (VCOI)		
L11			L40-1011-48	SMALL FIXED INDUCTOR(100UH)		
L12			L40-3382-48	SMALL FIXED INDUCTOR(0.33UH)		
L13		*	L34-4063-05	COIL (45.75MHZ)		
L14		*	L34-4065-05	COIL (45.75MHZ)		
L15		*	L34-4066-05	COIL (45.75MHZ)		
L16		*	L34-4067-05	COIL (10.7MHZ)		
L17 -19		*	L34-4064-05	COIL (45.75MHZ)		
L20		*	L34-4067-05	COIL (10.7MHZ)		
X1		*	L77-1360-05	CRYSTAL RESSNATOR(35.05MHZ)		
X2		*	L77-1359-05	CRYSTAL RESSNATOR(12.6MHZ)		
XF1		*	L71-0277-05	MCF (45N20AC)		
R1			RD41FB2B104J	CYLND CHIP R 100K J 1/8W		
R2			RD41FB2B103J	CYLND CHIP R 10K J 1/8W		
R3			RD41FB2B224J	CYLND CHIP R 220K J 1/8W		
R4			RD41FB2B470J	CYLND CHIP R 47 J 1/8W		
R5			RD41FB2B104J	CYLND CHIP R 100K J 1/8W		

FOR SERVICE MANUALS
CONTACT:
MAURITRON TECHNICAL SERVICE!
www.mauritron.co.uk
TEL: 01844 351694
FAX: 01844 352554

E: Scandinavia & Europe K: USA P: Canada W: Europe

U: PX(Far East, Hawaii) T: England M: Other Areas

UE: AAFES(Europe) X: Australia

indicates safety critical components.

PARTS LIST

× New Parts

Parts without Parts No. are not supplied.

Les articles non mentionnés dans le Parts No. ne sont pas fournis.

Telle ohne Parts No. werden nicht geliefert.

Ref. No. 参照番号	Address 位置	New Parts 新	Parts No. 部品番号	Description 部品名 / 規格	Desti- nation 仕 向	Re- marks 備考
R6			RD41FB2B101J	CYLND CHIP R 100 J 1/8W		
R7			RD41FB2B472J	CYLND CHIP R 4.7K J 1/8W		
R8			RD41FB2B101J	CYLND CHIP R 100 J 1/8W		
R9	.10		RD41FB2B103J	CYLND CHIP R 10K J 1/8W		
R11			RD41FB2B470J	CYLND CHIP R 47 J 1/8W		
R12			RD41FB2B101J	CYLND CHIP R 100 J 1/8W		
R13			RD41FB2B681J	CYLND CHIP R 680 J 1/8W		
R14			RD41FB2B473J	CYLND CHIP R 47K J 1/8W		
R15			RD41FB2B102J	CYLND CHIP R 1.0K J 1/8W		
R16			RD41FB2B680J	CYLND CHIP R 68 J 1/8W		
R17			RD41FB2B101J	CYLND CHIP R 100 J 1/8W		
R18			RD41FB2B224J	CYLND CHIP R 220K J 1/8W		
R19			RD41FB2B101J	CYLND CHIP R 100 J 1/8W		
R20			RD41FB2B152J	CYLND CHIP R 1.5K J 1/8W		
R21			RD41FB2B101J	CYLND CHIP R 100 J 1/8W		
R22			RD41FB2B224J	CYLND CHIP R 220K J 1/8W		
R23			RD41FB2B101J	CYLND CHIP R 100 J 1/8W		
R24	.25		RD41FB2B152J	CYLND CHIP R 1.5K J 1/8W		
R26			RD41FB2B473J	CYLND CHIP R 47K J 1/8W		
R27			RD41FB2B272J	CYLND CHIP R 2.7K J 1/8W		
R28			RD41FB2B223J	CYLND CHIP R 22K J 1/8W		
R29			RD41FB2B472J	CYLND CHIP R 4.7K J 1/8W		
R30			RD41FB2B333J	CYLND CHIP R 33K J 1/8W		
R31			RD41FB2B103J	CYLND CHIP R 10K J 1/8W		
R32			RD41FB2B222J	CYLND CHIP R 2.2K J 1/8W		
R33			RD41FB2B680J	CYLND CHIP R 68 J 1/8W		
R34			RD41FB2B153J	CYLND CHIP R 15K J 1/8W		
R35	.36		RD41FB2B104J	CYLND CHIP R 100K J 1/8W		
R37			RD41FB2B472J	CYLND CHIP R 4.7K J 1/8W		
R38			R92-0687-05	CHIP R 0 0AM		
R39			RD41FB2B223J	CYLND CHIP R 22K J 1/8W		
R40			RD41FB2B333J	CYLND CHIP R 33K J 1/8W		
R41			RD41FB2B221J	CYLND CHIP R 220 J 1/8W		
R42			RD41FB2B102J	CYLND CHIP R 1.0K J 1/8W		
R43			RD41FB2B183J	CYLND CHIP R 18K J 1/8W		
R44			RD41FB2B682J	CYLND CHIP R 6.8K J 1/8W		
R45			RD41FB2B821J	CYLND CHIP R 820 J 1/8W		
R46			RD41FB2B473J	CYLND CHIP R 47K J 1/8W		
R47			RD41FB2B272J	CYLND CHIP R 2.7K J 1/8W		
R48			RD41FB2B223J	CYLND CHIP R 22K J 1/8W		
R49			RD41FB2B472J	CYLND CHIP R 4.7K J 1/8W		
R50			RD41FB2B333J	CYLND CHIP R 33K J 1/8W		
R51			RD41FB2B103J	CYLND CHIP R 10K J 1/8W		
R52			RD41FB2B222J	CYLND CHIP R 2.2K J 1/8W		
R53			RD41FB2B680J	CYLND CHIP R 68 J 1/8W		
R54			RD41FB2B562J	CYLND CHIP R 5.6K J 1/8W		
R55			RD41FB2B472J	CYLND CHIP R 4.7K J 1/8W		
R56			RD41FB2B681J	CYLND CHIP R 680 J 1/8W		
R57			RD41FB2B562J	CYLND CHIP R 5.6K J 1/8W		
R58			RD41FB2B224J	CYLND CHIP R 220K J 1/8W		
R59			RD41FB2B221J	CYLND CHIP R 220 J 1/8W		
R60			RD41FB2B102J	CYLND CHIP R 1.0K J 1/8W		
R61			RD41FB2B104J	CYLND CHIP R 100K J 1/8W		
R62			RD41FB2B681J	CYLND CHIP R 680 J 1/8W		
R63			RD41FB2B123J	CYLND CHIP R 12K J 1/8W		

E: Scandinavia & Europe K: USA P: Canada W: Europe

U: PX(Far East, Hawaii) T: England M: Other Areas

UE: AAFES(Europe) X: Australia

⚠ indicates safety critical components.

PARTS LIST

× New Parts

Parts without Parts No. are not supplied.

Les articles non mentionnés dans le Parts No. ne sont pas fournis.

Telle ohne Parts No. werden nicht geliefert.

Ref. No. 参照番号	Address 位置	New Parts 新	Parts No. 部品番号	Description 部品名 / 規格	Desti- nation 仕向	Re- marks 備考
R64			RD41FB2B473J	CYLND CHIP R 47K J 1/8W		
R65			RD41FB2B391J	CYLND CHIP R 390 J 1/8W		
R66			RD41FB2B333J	CYLND CHIP R 33K J 1/8W		
R67			RD41FB2B273J	CYLND CHIP R 27K J 1/8W		
R68			RD41FB2B681J	CYLND CHIP R 680 J 1/8W		
R69			RD41FB2B562J	CYLND CHIP R 5.6K J 1/8W		
R70			RD41FB2B224J	CYLND CHIP R 220K J 1/8W		
R71			RD41FB2B221J	CYLND CHIP R 220 J 1/8W		
R72			RD41FB2B821J	CYLND CHIP R 820 J 1/8W		
R73			RD41FB2B104J	CYLND CHIP R 100K J 1/8W		
R74			RD41FB2B681J	CYLND CHIP R 680 J 1/8W		
R75 -78			RD41FB2B183J	CYLND CHIP R 18K J 1/8W		
R80			RD41FB2B222J	CYLND CHIP R 2.2K J 1/8W		
R82			RD41FB2B333J	CYLND CHIP R 33K J 1/8W		
R83			RD41FB2B223J	CYLND CHIP R 22K J 1/8W		
R84			RD41FB2B101J	CYLND CHIP R 100 J 1/8W		
R85			RD41FB2B182J	CYLND CHIP R 1.8K J 1/8W		
R86			RD41FB2B681J	CYLND CHIP R 680 J 1/8W		
VR1			R12-3096-05	TRIMMING PNT. (10K)		
D1			DAN235(K)	CHIP DIODE		
D2			15V166	CHIP DIODE		
D4 ,5			15V166	CHIP DIODE		
IC1		*	MB87006APF	IC(FREQ SYNTHESIZER PLL)		
IC2			MB501PF	IC(PRE SCALER)		
IC3		*	UPC1651G	IC(OP AMP)		
IC4			NJM4558M	IC(OP AMP X2)		
Q1			3SK131(K)	CHIP FET		
Q2			2SC2714(Y)	CHIP TRANSISTOR		
Q3			2SK302(Y)	CHIP FET		
Q4 ,5			2SC2714(Y)	CHIP TRANSISTOR		
Q6			3SK131(K)	CHIP FET		
Q7			DTC114EK	CHIP DIGITAL TRANSISTOR		
Q8 ,9			2SC2714(Y)	CHIP TRANSISTOR		
Q10			3SK131(K)	CHIP FET		
Q11 ,12			2SC2714(Y)	CHIP TRANSISTOR		
Q13			2SK302(Y)	CHIP FET		
Q14 ,15			DTC114EK	CHIP DIGITAL TRANSISTOR		
Q16			2SK302(Y)	CHIP FET		
Q17 ,18			2SC2714(Y)	CHIP TRANSISTOR		
Q19			2SK302(Y)	CHIP FET		
Q20 ,21			DTC114EK	CHIP DIGITAL TRANSISTOR		
Q22			2SC2714(Y)	CHIP TRANSISTOR		
Q23			DTC114EK	CHIP DIGITAL TRANSISTOR		
CONTROL UNIT (X53-3110-XX) -11 : K -21 : M -61 : W						
C1 -4			CC41FSL1H330J	CYLND CHIP C 33PF J		
C5 ,6			CK41FY1E102M	CYLND CHIP C 1000PF M		
C7 -12			CC41FSL1H330J	CYLND CHIP C 33PF J		
C13 -18			CK41FY1E102M	CYLND CHIP C 1000PF M		
C19 ,20			CC41FSL1H330J	CYLND CHIP C 33PF J		
C21 -25			CK41FY1E102M	CYLND CHIP C 1000PF M		
C27			CK73FB1H102K	CHIP C 1000PF K		
C28 ,29			CE04EW1H220M	ELECTOR 22UF 50WV		
C30			CK73FB1H102K	CHIP C 1000PF K		
C31			CK41FY1E102M	CYLND CHIP C 1000PF M		

www.mauritron.co.uk
TEL: 01844-351894
FAX: 01844-352554

FOR SERVICE MANUALS
CONTACT:
MAURITRON TECHNICAL SERVICES

E: Scandinavia & Europe K: USA P: Canada W: Europe

U: PX(Far East, Hawaii) T: England M: Other Areas

UE: AAFES(Europe) X: Australia

⚠ indicates safety critical components.

PARTS LIST

* New Parts

Parts without Parts No. are not supplied.

Les articles non mentionnés dans le Parts No. ne sont pas fournis.

Teile ohne Parts No. werden nicht geliefert.

Ref. No. 参照番号	Address 位置	New Parts 新	Parts No. 部品番号	Description 部品名 / 規格	Desti- nation 仕向	Re- marks 備考
C32			CE04EW1C470M	ELECTRØ 47UF 16WV		
C33			CC73FCH1H330J	CHIP C 33PF J		
C34			CC73FCH1H220J	CHIP C 22PF J		
C35			C92-0504-05	CHIP-TAN 0.68UF 20WV		
C36 ,37			CK73FF1E104Z	CHIP C 0.10UF Z		
C38 ,39			CK41FY1E102M	CYLND CHIP C 1000PF M		
C40			CE04EW1A470M	ELECTRØ 47UF 10WV		
C41			CK41FY1E102M	CYLND CHIP C 1000PF M		
C42			C90-2041-05	ELECTRØ 10UF 10WV		
C43			CK41FY1E102M	CYLND CHIP C 1000PF M		
C44			CE04EW1C470M	ELECTRØ 47UF 16WV		
C45			CE04EW1A470M	ELECTRØ 47UF 10WV		
C46			CK41FY1E102M	CYLND CHIP C 1000PF M		
C47 -50			CC73FCH1H101J	CHIP C 100PF J		
TC1			C05-0350-05	TRIMMING CAP (20PF)		
CN1		*	E40-5149-05	PIN CONNECTØR (EP 13P)		
CN2		*	E40-5148-05	PIN CONNECTØR (EP 12P)		
CN3			E40-5033-05	FPC CONNECTØR (5597-09CPB)		
CN4		*	E40-3523-05	PIN CONNECTØR (5532-12A)		
CN5 ,6			E40-5157-05	PIN CONNECTØR (B11P-SHF-1AA)		
TP1 ,2			E23-0465-05	TERMINAL		
L1			L40-1011-48	SMALL FIXED INDUCTØR(100UH)		
L2			L33-0701-05	CHIP COIL (270UH)		
X1		*	L78-0041-05	RESØNATØR (CSA 8.00MT)		
CP1 ,2			R90-0461-05	MULTI-COMP 47KX6 J 1/6W		
CP3			R90-0274-05	MULTI-COMP 47KX5 J 1/6W		
CP4 ,5			R90-0462-05	MULTI-COMP 47KX8 J 1/4W		
CP6			R90-0202-05	MULTI-COMP 47KX4 J 1/6W		
CP7			R90-0462-05	MULTI-COMP 47KX8 J 1/4W		
CP8			R90-0461-05	MULTI-COMP 47KX6 J 1/6W		
R1			RD14BB2C220J	RD 22 J 1/6W		
R4 ,5			R92-0687-05	CHIP R 0 ØHM		
R6			RD41FB2B103J	CYLND CHIP R 10K J 1/8W		
R7			RD41FB2B220J	CYLND CHIP R 22 J 1/8W		
R8 ,9			RD41FB2B473J	CYLND CHIP R 47K J 1/8W		
R10 -13			R92-0687-05	CHIP R 0 ØHM		
R14			RD41FB2B105J	CYLND CHIP R 1.0M J 1/8W		
R15			RD41FB2B473J	CYLND CHIP R 47K J 1/8W		
R18			RD41FB2B473J	CYLND CHIP R 47K J 1/8W		
R19			RD41FB2B681J	CYLND CHIP R 68Ø J 1/8W		
R20			RD41FB2B102J	CYLND CHIP R 1.0K J 1/8W		
R21			R92-0687-05	CHIP R 0 ØHM		
R22 -25			R92-0687-05	CHIP R 0 ØHM		
R23 ,24			R92-0687-05	CHIP R 0 ØHM		
D1 -4			RLS73	CHIP DIØDE		
D5			RLZ33B	CHIP ZENER DIØDE		
D6			1S5226	CHIP DIØDE		
IC1		*	MS0747-744-FP	IC(MICROPROCESSØR)		
IC2		*	TC5518CFL-15	IC(2KX8 RAM)		
IC3 ,4		*	MSM82C55AFP-5	IC(MICROPROCESSØR)		
IC5		*	TC74HC139F	IC(2-10-4 LINE DECODER)		
IC6			TC74HC14F	IC(HEX SCHUMITT INVERTER)		
IC7			PST523C	IC(SYSTEM RESET)		
IC8		*	NJM78L06UA	IC(VOLTAGE REGULATØR/ +6V)		

E: Scandinavia & Europe K: USA P: Canada W: Europe

U: PX(Far East, Hawaii) T: England M: Other Areas

UE: AAFES(Europe) X: Australia

△ indicates safety critical components.

PARTS LIST

× New Parts

Parts without Parts No. are not supplied.

Les articles non mentionnés dans le Parts No. ne sont pas fournis.

Teile ohne Parts No. werden nicht geliefert.

Ref. No. 参照番号	Address 位置	New Parts 新	Parts No. 部品番号	Description 部品名 / 規格	Desti- nation 仕向	Re- marks 備考
01			DTC144EK	DIGITAL TRANSISTOR		
-		*	W02-0808-05	MODULE UNIT(DC/DC CONV CAP1181A		
FM MPX (X58-3310-11)						
C1	-5		CK73FB1E223K	CHIP C 0.022UF K		
C6			C90-0824-05	ELECTRO 1UF 50WV		
C7			C90-0481-05	ELECTRO 3.3UF 50WV		
C8			C90-0477-05	ELECTRO 0.1UF 50WV		
C9			CK73FB1E223K	CHIP C 0.022UF K		
C10			C90-0506-05	ELECTRO 0.22UF 50WV		
C11			CC41FSL1H151J	CYLND CHIP C 150PF J		
C12			C90-2062-05	ELECTRO 100UF 16WV		
C13	-15		C90-0478-05	ELECTRO 10UF 16WV		
C16			C90-2060-05	ELECTRO 22UF 16WV		
C17			CK73FF1E473Z	CHIP C 0.047UF Z		
C18			C90-2062-05	ELECTRO 100UF 16WV		
C19			CK73FB1H332K	CHIP C 3300PF K		
C20			C90-0482-05	ELECTRO 4.7UF 25WV		
C21			C90-2062-05	ELECTRO 100UF 16WV		
C22			CK73FB1E273K	CHIP C 0.027UF K		
C23			CK73FB1H103K	CHIP C 0.010UF K		
C24			CC73FCH1H240J	CHIP C 24PF J		
C25			C90-0506-05	ELECTRO 0.22UF 50WV		
C26			C90-0824-05	ELECTRO 1UF 50WV		
C27			C90-0482-05	ELECTRO 4.7UF 25WV		
C28	,29		CK73FB1H153K	CHIP C 0.015UF K		
C30	,31		CK41FY1E152M	CYLND CHIP C 1500PF M		
C32	,33		CF92V1H563J	MF 0.056UF J		
C34			C90-0478-05	ELECTRO 10UF 16WV		
C35			C90-2062-05	ELECTRO 100UF 16WV		
C36	,37		CC41FSL1H101J	CYLND CHIP C 100PF J		
C38			C90-0478-05	ELECTRO 10UF 16WV		
C39	,40		C90-2053-05	ELECTRO 47UF 6.3WV		
C41			CE04EW1A471M	ELECTRO 470UF 10WV		
C42	,43		CK73FB1H272K	CHIP C 2700PF K		
C44	,45		C90-2053-05	ELECTRO 47UF 6.3WV		
C46			C90-2060-05	ELECTRO 22UF 16WV		
C47			CC73FCH1H330J	CHIP C 33PF J		
C48			C90-0477-05	ELECTRO 0.1UF 50WV		
C49			CK73FB1E223K	CHIP C 0.022UF K		
CN1	,2	*	E40-5150-05	PIN CONNECTOR (8P)		
TP1			E40-0211-05	PIN CONNECTOR		
L1		*	L78-0208-05	RESONATOR (CSB456F11)		
R1			RD41FB2B331J	CYLND CHIP R 330 J 1/8W		
R2			RD41FB2B102J	CYLND CHIP R 1.0K J 1/8W		
R3			RD41FB2B822J	CYLND CHIP R 8.2K J 1/8W		
R4	,5		RD41FB2B103J	CYLND CHIP R 10K J 1/8W		
R6			RD41FB2B473J	CYLND CHIP R 47K J 1/8W		
R7			RD41FB2B683J	CYLND CHIP R 68K J 1/8W		
R8			RD41FB2B153J	CYLND CHIP R 15K J 1/8W		
R9			RD41FB2B270J	CYLND CHIP R 27 J 1/8W		
R10			RD41FB2B334J	CYLND CHIP R 330K J 1/8W		
R11			RD41FB2B472J	CYLND CHIP R 4.7K J 1/8W		

FOR SERVICE MANUALS
 CONTACT:
MAURITRON TECHNICAL SERVICES
 www.mauritron.co.uk
 TEL: 01844 - 351694
 FAX: 01844 - 352554

E: Scandinavia & Europe K: USA P: Canada W: Europe

U: PX(Far East, Hawaii) T: England M: Other Areas

UE: AAFES(Europe) X: Australia

indicates safety critical components.

PARTS LIST

× New Parts

Parts without Parts No. are not supplied.

Les articles non mentionnés dans le Parts No. ne sont pas fournis.

Teile ohne Parts No. werden nicht geliefert.

Ref. No. 参照番号	Address 位置	New Parts 新	Parts No. 部品番号	Description 部品名 / 規格	Desti- nation 仕向	Re- marks 備考
R12			RD41FB2B183J	CYLND CHIP R 18K J 1/8W		
R13			RD41FB2B473J	CYLND CHIP R 47K J 1/8W		
R14			RD41FB2B105J	CYLND CHIP R 1.0M J 1/8W		
R15			RD41FB2B220J	CYLND CHIP R 22 J 1/8W		
R16			RD41FB2B222J	CYLND CHIP R 2.2K J 1/8W		
R17			RD41FB2B104J	CYLND CHIP R 100K J 1/8W		
R18			RD41FB2B102J	CYLND CHIP R 1.0K J 1/8W		
R19			RD41FB2B203J	CYLND CHIP R 20K J 1/8W		
R20			RD41FB2B472J	CYLND CHIP R 4.7K J 1/8W		
R21			RD41FB2B104J	CYLND CHIP R 100K J 1/8W		
R22			RD41FB2B473J	CYLND CHIP R 47K J 1/8W		
R23			RD41FB2B220J	CYLND CHIP R 22 J 1/8W		
R24			RD41FB2B473J	CYLND CHIP R 47K J 1/8W		
R25			RD41FB2B223J	CYLND CHIP R 22K J 1/8W		
R26			RD41FB2B104J	CYLND CHIP R 100K J 1/8W		
R28			RD41FB2B333J	CYLND CHIP R 33K J 1/8W		
R29 ,30			RD41FB2B332J	CYLND CHIP R 3.3K J 1/8W		
R31 ,32			RD41FB2B472J	CYLND CHIP R 4.7K J 1/8W		
R33			RD41FB2B103J	CYLND CHIP R 10K J 1/8W		
R34 ,35			RD41FB2B473J	CYLND CHIP R 47K J 1/8W		
R36 -39			RD41FB2B103J	CYLND CHIP R 10K J 1/8W		
R40 ,41			RD41FB2B182J	CYLND CHIP R 1.8K J 1/8W		
R42 ,43			RD41FB2B152J	CYLND CHIP R 1.5K J 1/8W		
R44			RD41FB2B101J	CYLND CHIP R 100 J 1/8W		
R45 ,46			RD41FB2B103J	CYLND CHIP R 10K J 1/8W		
R47			RD41FB2B104J	CYLND CHIP R 100K J 1/8W		
R48			RD41FB2B103J	CYLND CHIP R 10K J 1/8W		
R49 -51			RD41FB2B104J	CYLND CHIP R 100K J 1/8W		
R52			RD41FB2B183J	CYLND CHIP R 18K J 1/8W		
R53			RD41FB2B103J	CYLND CHIP R 10K J 1/8W		
R54 ,55			RD41FB2B101J	CYLND CHIP R 100 J 1/8W		
R75			R92-0687-05	CHIP R 0 0HM		
R76			R92-0338-05	CYLND CHIP R 0 0HM		
R77 -80			R92-0687-05	CHIP R 0 0HM		
R78			RD41FB2B473J	CYLND CHIP R 47K J 1/8W		
VR1			R12-3133-05	TRIMMING PNT. (47K)		
VR2			R12-3127-05	TRIMMING PNT. (10K)		
VR3 ,4			R12-3133-05	TRIMMING PNT. (47K)		
VR5			R12-3127-05	TRIMMING PNT. (10K)		
VR6			R12-3133-05	TRIMMING PNT. (47K)		
VR7			R12-5059-05	TRIMMING PNT. (100K)		
D1 -8			RLS73	CHIP DIODE		
IC1		*	LA1140	IC(FM IF/DETECTION)		
IC2		*	KC-820A	IC(NOISE CANCELLER)		
IC3		*	LA3430	IC(FM MPX)		
IC4			NJM4558M	IC(OP AMP X2)		
Q1			2SC2712(Y)	CHIP TRANSISTOR		
Q2			2SK208(Y)	CHIP FET		
Q3 ,4			DTC144EK	DIGITAL TRANSISTOR		
Q5			2SA1162(Y)	CHIP TRANSISTOR		
Q6 -10			2SC2712(Y)	CHIP TRANSISTOR		
Q11			DTC144EK	DIGITAL TRANSISTOR		
Q12 ,13		*	2SD1757(K)	CHIP TRANSISTOR		

E: Scandinavia & Europe K: USA P: Canada W: Europe

U: PX(Far East, Hawaii) T: England M: Other Areas

UE: AAFES(Europe) X: Australia

⚠ indicates safety critical components.

PARTS LIST

× New Parts

Parts without Parts No. are not supplied.

Les articles non mentionnés dans le Parts No. ne sont pas fournis.

Teile ohne Parts No. werden nicht geliefert.

Ref. No. 参照番号	Address 位置	New Parts 新	Parts No. 部品番号	Description 部品名 / 規格	Desti- nation 仕向	Re- marks 備考
1F (X59-3140-00)						
C1			CK73FB1H102K	CHIP C 1000PF K		
C2			CK73FB1H472K	CHIP C 4700PF K		
C3			CC73FCH1H330J	CHIP C 33PF J		
C4			CK73FB1H472K	CHIP C 4700PF K		
C5			CC73FSL1H561J	CHIP C 560PF J		
C6			CK73FB1H472K	CHIP C 4700PF K		
C7			CK73FB1H103K	CHIP C 0.010UF K		
C8	-10		CK73EB1H104K	CHIP C 0.10UF K		
-			E23-0471-05	TERMINAL		
L1			L40-2211-B1	SMALL FIXED INDUCTOR(220UH)		
L2			L33-0695-05	CHIP CHOKE COIL		
R1	.2		RD41FB2B104J	CYLND CHIP R 100K J 1/8W		
R4			RD41FB2B332J	CYLND CHIP R 3.3K J 1/8W		
R5			RD41FB2B182J	CYLND CHIP R 1.8K J 1/8W		
IC1			TA7761F	IC(FM 1F)		
SQL (X59-3150-00)						
C1			CK73FB1H102K	CHIP C 1000PF K		
C2			CC73FCH1H330J	CHIP C 33PF J		
C4			C92-0005-05	CHIP-TAN 2.2UF 6.3WV		
C5			CK73EF1C105Z	CHIP C 1.0UF Z		
C6			C92-0504-05	CHIP-TAN 0.68UF 20WV		
C7	.8		CK73FB1E393K	CHIP C 0.039UF K		
C9			CK73FB1H153K	CHIP C 0.015UF K		
C10			CK73FB1H333K	CHIP C 0.033UF K		
-			E23-0471-05	TERMINAL		
R1			RD41FB2B104J	CYLND CHIP R 100K J 1/8W		
R2			RD41FB2B272J	CYLND CHIP R 2.7K J 1/8W		
R3			RD41FB2B222J	CYLND CHIP R 2.2K J 1/8W		
R4			RD41FB2B223J	CYLND CHIP R 22K J 1/8W		
R5			RD41FB2B332J	CYLND CHIP R 3.3K J 1/8W		
R6			RD41FB2B682J	CYLND CHIP R 6.8K J 1/8W		
R7			RD41FB2B103J	CYLND CHIP R 10K J 1/8W		
R8			RD41FB2B474J	CYLND CHIP R 470K J 1/8W		
R9			RD41FB2B472J	CYLND CHIP R 4.7K J 1/8W		
R10			RD41FB2B474J	CYLND CHIP R 470K J 1/8W		
R11			RD41FB2B273J	CYLND CHIP R 27K J 1/8W		
R12			RD41FB2B223J	CYLND CHIP R 22K J 1/8W		
R13			RD41FB2B222J	CYLND CHIP R 2.2K J 1/8W		
R14			RD41FB2B393J	CYLND CHIP R 39K J 1/8W		
R15			RD41FB2B273J	CYLND CHIP R 27K J 1/8W		
R16			RD41FB2B331J	CYLND CHIP R 330 J 1/8W		
R17			RD41FB2B222J	CYLND CHIP R 2.2K J 1/8W		
D1			1SS224	CHIP DIODE		
D2			1SS101	CHIP DIODE		
Q1	.2		2SC2712(Y)	CHIP TRANSISTOR		
Q3	.4		2SC3295(B)	CHIP TRANSISTOR		
Q5	.6		2SC2712(Y)	CHIP TRANSISTOR		
SM (X59-3380-00)						
C1			C92-0004-05	CHIP TAN 1UF 16WV		

MAURIFRON TECHNICAL SERVICES

FOR SERVICE MANUALS
CONTACT:

www.maurifron.co.uk
TEL: 01844 - 351694
FAX: 01844 - 352554

E: Scandinavia & Europe K: USA P: Canada W: Europe

U: PX(Far East, Hawaii) T: England M: Other Areas

UE: AAFES(Europe) X: Australia

indicates safety critical components.

PARTS LIST

* New Parts

Parts without Parts No. are not supplied.

Les articles non mentionnés dans le Parts No. ne sont pas fournis.

Teile ohne Parts No. werden nicht geliefert.

Ref. No. 参照番号	Address 位置	New Parts 新	Parts No. 部品番号	Description 部品名/規格	Desti- nation 仕向	Re- marks 備考
C2			CK73FB1E223K	CHIP C 0.022UF K		
C3			CK73FB1E393K	CHIP C 0.039UF K		
C4			C92-0005-05	CHIP-TAN 2.2UF 6.3WV		
C5			CK73EF1C105Z	CHIP C 1.0UF Z		
C6			C92-0504-05	CHIP-TAN 0.68UF 20WV		
-			E23-0471-05	TERMINAL		
R1			RD41FB2B103J	CYLND CHIP R 10K J 1/8W		
R2			RD41FB2B473J	CYLND CHIP R 47K J 1/8W		
R3			RD41FB2B474J	CYLND CHIP R 470K J 1/8W		
R4			RD41FB2B473J	CYLND CHIP R 47K J 1/8W		
R5			RD41FB2B563J	CYLND CHIP R 56K J 1/8W		
R6			RD41FB2B123J	CYLND CHIP R 12K J 1/8W		
R7			RD41FB2B334J	CYLND CHIP R 330K J 1/8W		
R8			RD41FB2B224J	CYLND CHIP R 220K J 1/8W		
R9			RD41FB2B332J	CYLND CHIP R 3.3K J 1/8W		
R10			RD41FB2B223J	CYLND CHIP R 22K J 1/8W		
R11			RD41FB2B103J	CYLND CHIP R 10K J 1/8W		
R12			RD41FB2B682J	CYLND CHIP R 6.8K J 1/8W		
R13			RD41FB2B474J	CYLND CHIP R 470K J 1/8W		
R14 ,15			RD41FB2B472J	CYLND CHIP R 4.7K J 1/8W		
R16 ,17			R92-06B7-05	CHIP R 0.8HM		
D1			1SS184	CHIP DIODE		
D2			1SS226	CHIP DIODE		
D3			1SS181	CHIP DIODE		
IC1			NJM4558M	IC(OP AMP X2)		
Q1			2SC2712(Y)	CHIP TRANSISTOR		
Q2 ,3			2SC3295(B)	CHIP TRANSISTOR		

FOR SERVICE MANUALS
CONTACT:
MAURITRON TECHNICAL SERVICES
www.mauritron.co.uk
TEL: 01844 - 351694
FAX: 01844 - 352554

E: Scandinavia & Europe K: USA P: Canada W: Europe

U: PX(Far East, Hawaii) J: England M: Other Areas

UE: AAFES(Europe) X: Australia

▲ indicates safety critical components.

DISASSEMBLY

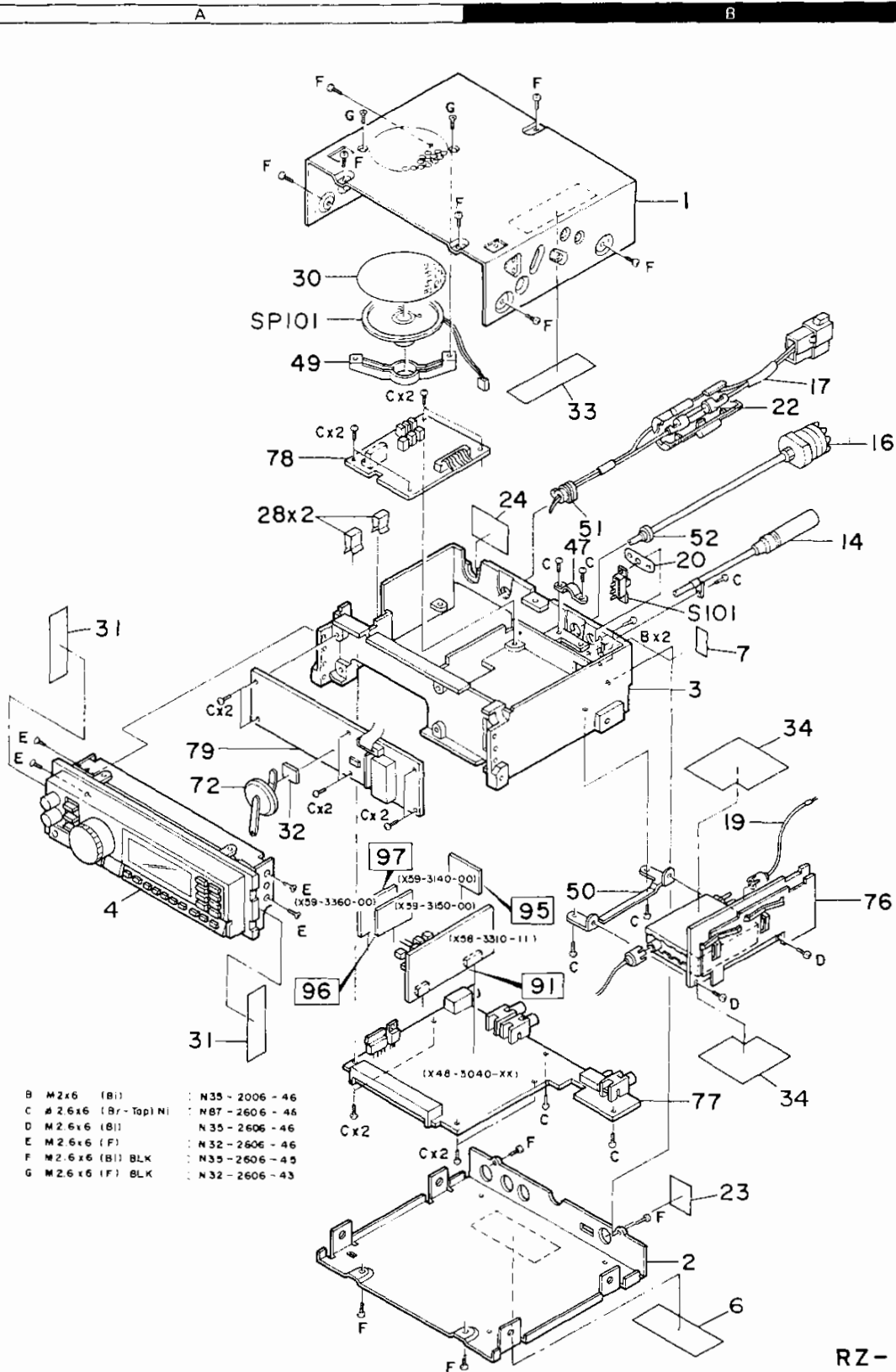

RZ-1

DISASSEMBLY

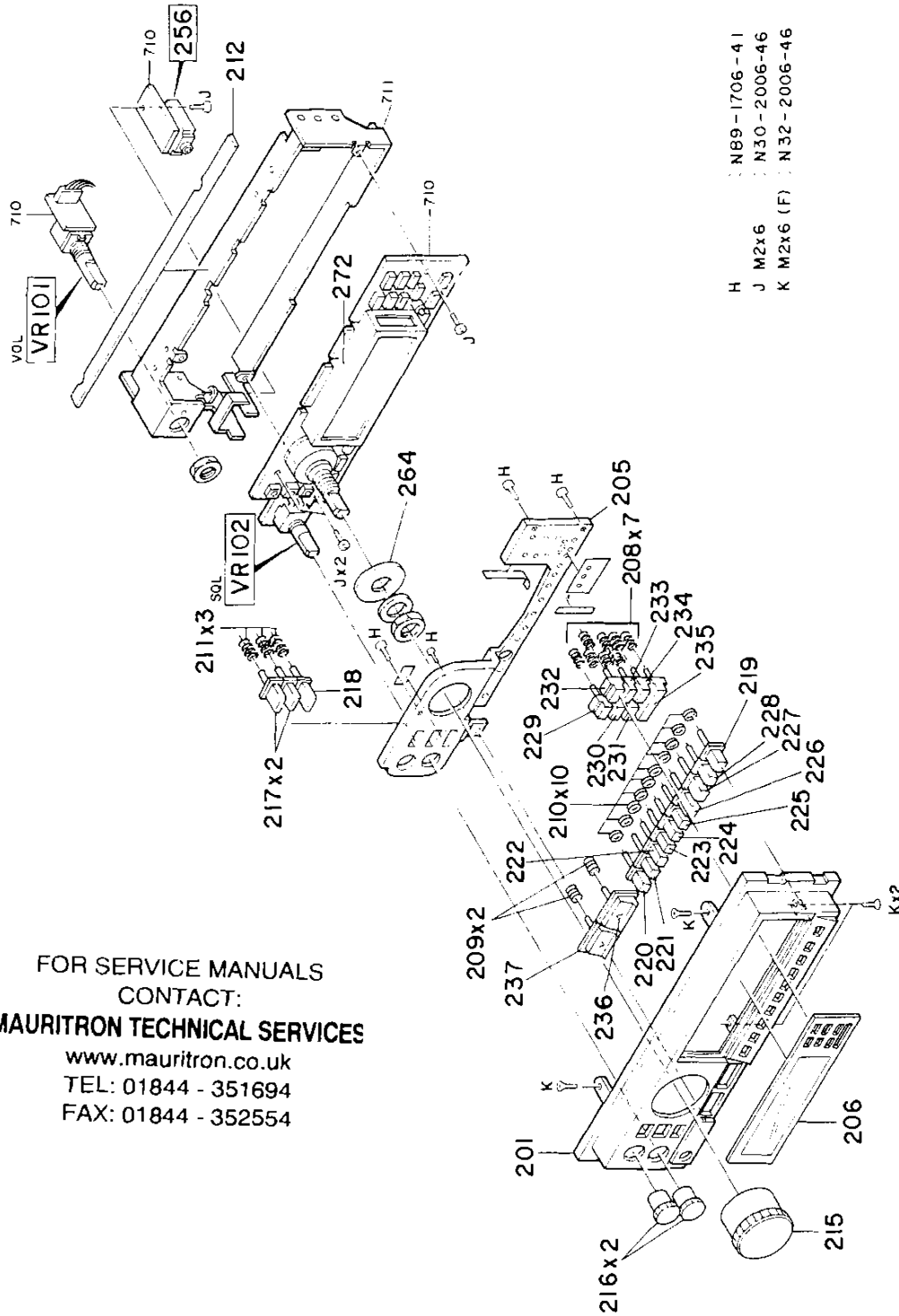

- H : N89-1706-41
- J M2x6 : N30-2006-46
- K M2x6 (F) : N32-2006-46

RZ-1

FOR SERVICE MANUALS
CONTACT:
MAURITRON TECHNICAL SERVICES
www.mauritron.co.uk
TEL: 01844 - 351694
FAX: 01844 - 352554

PACKING

FOR SERVICE MANUALS
CONTACT:
MAURITRON TECHNICAL SERVICES
www.mauritron.co.uk
TEL: 01844 - 351694
FAX: 01844 - 352554

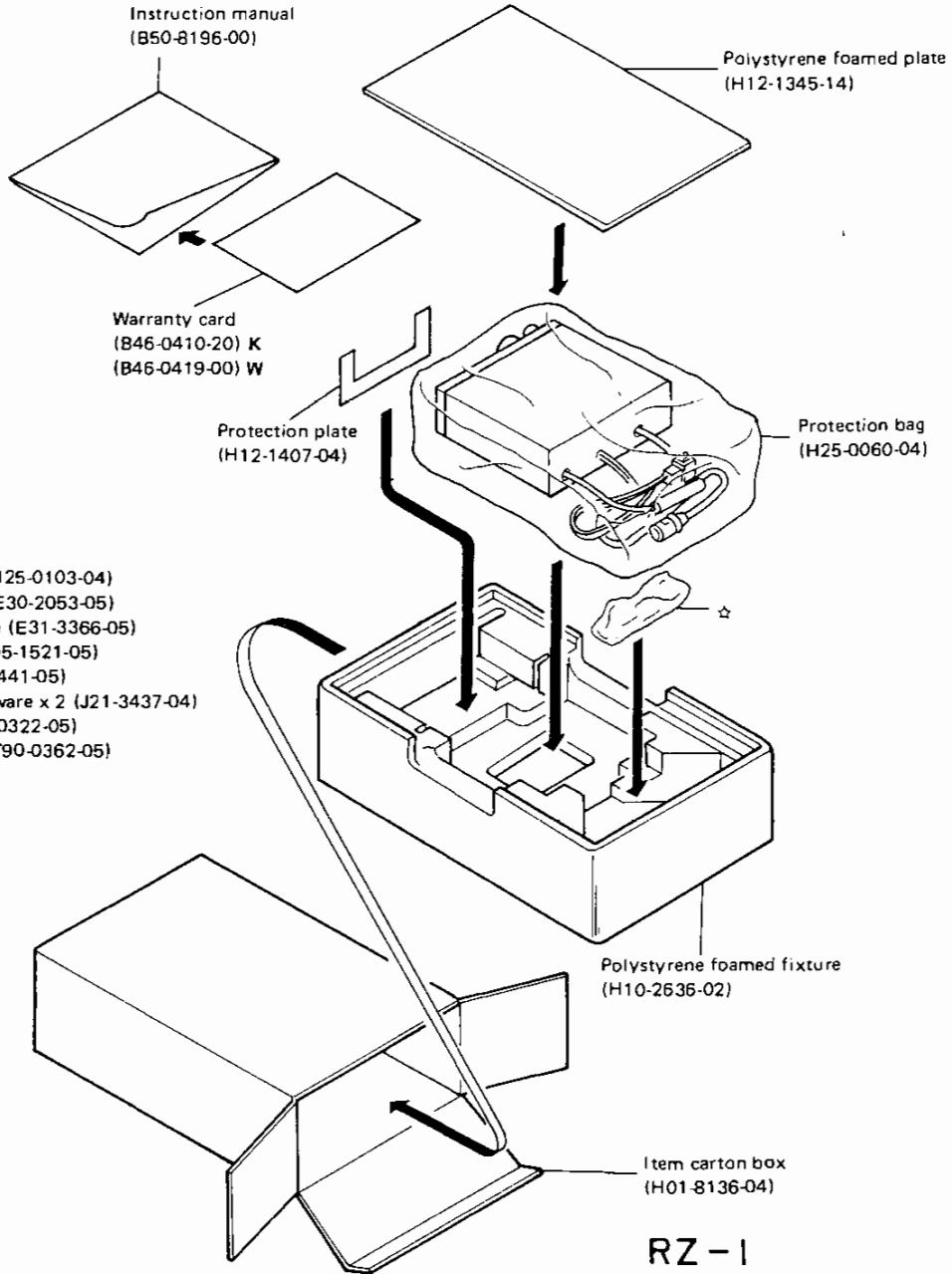

- ☆ Protection bag (H25-0103-04)
- DC cord ass'y (E30-2053-05)
- Connecting wire (E31-3366-05)
- Fuse (1.5A) (F05-1521-05)
- Foot x 4 (J02-0441-05)
- Mounting hardware x 2 (J21-3437-04)
- Screw set (N99-0322-05)
- Lead antenna (T90-0362-05)

RZ-1

ADJUSTMENT

REQUIRED TEST EQUIPMENT

1. **DC V.M**
High input impedance.
2. **RF VTVM (RF V.M)**
Input impedance : $1M\Omega$ min., $2pF$ max.
Voltage range : F.S = $100mV$ to $300V$.
Frequency range : Up to $450MHz$.
3. **Frequency counter (f. counter)**
Input sensitivity : Approx. $50mV$.
Frequency range : Up to $450MHz$.
4. **DC power supply**
Voltage : $10V$ to $17V$, variable.
Current : $3A$ max.
5. **AF VTVM (AF V.M)**
Input impedance : $1M\Omega$ min.
Voltage range : F.S = $1mV$ to $30V$.
Frequency range : $50Hz$ to $10kHz$.
6. **Oscilloscope**
High sensitivity oscilloscope with horizontal terminal.
7. **SSG**
Frequency range : $950MHz$.
Modulation : AM and FM MOD.
Output level : $-20dB$ to $100dB$.
8. **Dummy load**
 8Ω , $5W$.
9. **Sweep generator**
Sweep range : $500kHz$ to $950MHz$ bands.

10. **FM-MPX stereo modulator (FM-MPX)**
Adjust for FM-W mode.
11. **Distortion meter**
Adjust for FM-W mode.
12. **Pattern generator**
Adjust for Video.
13. **Monitor television**
Adjust for Video.

PREPARATION

- Unless to otherwise specified, knobs and switches should be set as follows Table 6.

Front panel		Rear panel	
POWER SW	OFF	ANT SW	AUTO
SQL VOL	CCW MAX.	ATT SW	OFF

Table 6

- Use an insulated adjusting rod to adjust trimmers and coils.
- Be sure to turn the POWER SW OFF, before connecting the power cable to a power source.
- SSG output level are those at the time the output terminal is open (E.M.F.).

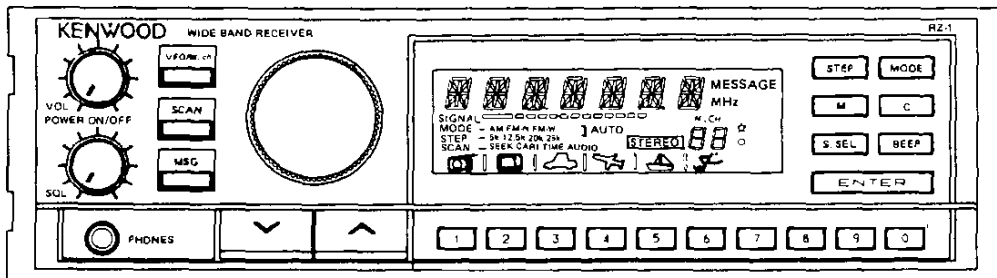

Fig. 20

FOR SERVICE MANUALS
CONTACT:
MAURITRON TECHNICAL SERVICES
www.mauritron.co.uk
TEL: 01844 - 351694
FAX: 01844 - 352554

ADJUSTMENT

Item	Condition	Measurement			Adjustment			Specifications/Remarks
		Test-equipment	Unit	Terminal	Unit	Parts	Method	
1. Setting	1) Power supply : 13.8V DC POWER SW : ON							"KENWOOD" and all marks appeared. Then after past 5 sec., display will indicate to frequency and memory channel.
2-1. Reset	1) Turn the POWER SW : ON, holding the ENTER key. 2) Release the ENTER key.						"KENWOOD" appeared during 1 sec. Then display all indicated.	76.100.0 MODE : FM-W STEP : 25k SCAN : SEEK
2-2. Fully reset	1) Turn the POWER SW : ON, holding the M and A key down.						Same as shown 2-1. Also all memorized frequency disappeared.	
3. VCO voltage	1) F : 22.245.0 (22.245MHz)	DC V.M	PLL	TP1 (3E)	PLL	L10 (3E)	18.0V	±0.1V
	2) F : 500.0 (500kHz)					Check	3.0V ± 2.0V	
	3) F : 59.995.0 (59.995MHz)					L7 (3E)	26.0V	±0.1V
	4) F : 22.250.0 (22.250MHz)					Check	3.0V ± 1.0V	
	5) F : 104.995.0 (104.995MHz)					25.0V ± 4.0V		
	6) F : 249.995.0 (249.995MHz)					28.0V ± 3.0V		
	7) F : 469.995.0 (469.995MHz)					26.0V ± 4.0V		
	8) F : 824.000.0 (824MHz) K F : 905.000.0 (905MHz) M,W					26.0V ± 5.0V		
4. OSC frequency	1) Frequency and MODE : Free	f. counter	PLL	TP2 (4E)	PLL	TC2 (4E)	12.600.0MHz	±10Hz
5. HET frequency	1) F : 824.000.0 (824MHz) K F : 905.000.0 (905MHz) M,W	f. counter	PLL	TP3 (4D)	PLL	TC1 (4D)	35.050.0MHz	±100Hz
	2) F : 823.995.0 (823.995MHz) K F : 904.995.0 (904.995MHz) M,W 5kHz down from item 1).					VR1 (4E)	35.045.0MHz	±100Hz
6. AM sensitivity	1) F : 1000.0 (1MHz) K F : 999.0 (999kHz) M,W MODE : AM SSG F : 1000kHz K SSG F : 999kHz M,W SSG MODE : AM SSG output : 26dBμ (EMF) (-81dBm) SSG MOD : 400Hz SSG DEV : 30% SQL VR : Fully CCW	SSG AF V.M Oscilloscope 8Ω dummy	Rear panel	EXT.SP (2A)	PLL	L13 ~ L16 (3D)	AF MAX. Repeat for MAX.	MAX. sensitivity more than 0.63V/8Ω.
						IF	L1 (3A) L2 (3B) L6 (3B) L8 (3B)	S/N ratio MAX. Repeat for MAX.
7. AM stop	1) SSG output : 36dBμ (EMF) (-71dBm) Other conditions : As same as above item 6.			Front panel	BUSY lamp	IF	VR3 (3C)	Turn the VR3 clockwise to the point at which signal meter just light on.

FOR SERVICE MANUALS
CONTACT:
MAURITRON TECHNICAL SERVICES
www.mauritron.co.uk
TEL: 01844 - 351694
FAX: 01844 - 352554

ADJUSTMENT

Item	Condition	Measurement			Adjustment			Specifications/Remarks
		Test-equipment	Unit	Terminal	Unit	Parts	Method	
3. FM-N discri.	1) F : 145.020.0 (145.02MHz) MODE : FM-N Connect the SSG to ANT2 terminal. SSG F : 145.02MHz SSG MODE : FM SSG output : 30dBμ (EMF) (-77dBm) SSG MOD : 1kHz, SSG DEV : 3kHz	SSG AF V.M Oscillo- scope 8Ω dummy	Rear panel	EXT. SP (2A)	IF	L4 (3B)	Waveform MAX.	
3. FM-N S-meter	1) Conditions : As same as item 8.		Front panel	S-meter	IF	VR1 (3C)	Set the SIGNAL scale to reads "all digits"	
10. FM-W S-meter	1) F : 98.000.0 (98MHz) MODE : FM-W SSG F : 98MHz SSG output : 6dBμ (EMF) (-101dBm) SSG MOD : 1kHz SSG DEV : 75kHz External MOD. FM MPX SSG MODE SELECTOR : MON1 MOD : 1kHz FM MPX unit VR5 : Fully CCW	SSG FM MPX Distortion meter AF V.M Oscillo- scope 8Ω dummy	Rear panel	EXT. SP (2A)	PLL	L17 ~ L19 (30) L20 (4D)	<ul style="list-style-type: none"> • Turn the core of L18 one turn down the case surface level. • Repeat the adjustment of L17 and L19 to obtain the MAX. deflection. • Repeat the adjustment of L20 to obtain the AF MAX. and same balance for wave. 	
2)		Check						Distortion IHF : Less than 3%.
1. FM-W discri.	1) SSG output : 60dBμ (EMF) (-47dBm) SSG DEV : OFF Other conditions : As same as above item 10.		FM MPX	TP1 (4C)	IF	L11 (4C)	0V	±20mV
2. FM-W stop	1) SSG output : 20dBμ (EMF) (-87dBm) Other conditions : As same as above item 10.		Front panel	BUSY lamp	FM MPX	VR4 (3C)	Turn the VR4 clockwise to the point at which signal meter just light on.	
3. FM-W S-meter	1) SSG output : 60dBμ (EMF) (-47dBm) Other conditions : As same as above item 10.		Front panel	S-meter	FM MPX	VR3 (4C)	Set the SIGNAL scale to reads "all digits".	
4. Pilot canceling	1) FM MPX SSG PILOT : ON MAIN signal : OFF Other conditions : As same as above item 10.		Rear panel	EXT. SP (2A)	FM MPX	VR6 (3C)	AF output for MIN.	

ADJUSTMENT

Item	Condition	Measurement			Adjustment			Specifications/Remarks
		Test-equipment	Unit	Terminal	Unit	Parts	Method	
15. Separation	1) F : 98.000.0 (98MHz) MODE : FM-W SSG F : 98MHz SSG MODE : FM FM MPX SSG MOD : 1kHz DEV : 68.25kHz AMPLITUDE : + or - MAIN signal : 90% PILOT signal : 9% Connect the dummy load (100pF, 10kΩ) to ANT2 terminal with AF V.M or oscilloscope. (Need two AF V.M)	SSG FM MPX AF V.M Oscilloscope	Rear panel	L jack R jack	FM MPX	VR2 (3C)	Check to L & R output with AF V.M or oscilloscope. Then, change the level of L & R. Level should be 30dB ratio.	
	2)						Change the AF V.M reading from L & R jack's.	30dB or more.
16. ANRC	1) SSG output : 26dBμ (EMF) (-81dBm) Other conditions : As same as above item 15. FM MPX output : Change to L & R.				FM MPX	VR5 (3C)	5dB (Separation of L & R jack)	
17. Soft mute	1) SSG output : 60dBμ (EMF) (-47dBm) SSG MODE : FM SSG MOD : 1kHz SSG DEV : 75kHz						AF output level standardized.	
	2) SSG output : OFF				FM MPX	VR1 (4C)	Within -25dB ~ -30dB.	
18. Video K type only	1) F : 181.175.0 (181.175MHz) IF unit VR5 : CW MAX. Pattern generator Oscilloscope Pattern : Color Channel : 3 Connect the DC V.M to TP1 of the IF unit.	Pattern generator Oscilloscope AF V.M DC V.M Monitor TV	IF	TP1 (2D)	IF	L12,13 (2C) L14 (2D)	Voltage MIN. Repeat 2 times.	3.6V or less (Ref. level)
19. Beep level	1) AF VR : Fully CCW Press 1 key.	Oscilloscope 8Ω dummy	Rear panel	EXT. SP (2A)	IF	VR4 (4B)	Check AF output with oscilloscope.	800mV ± 100mVp-p

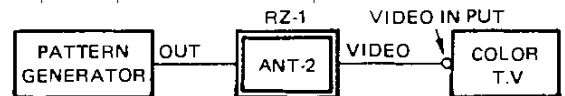
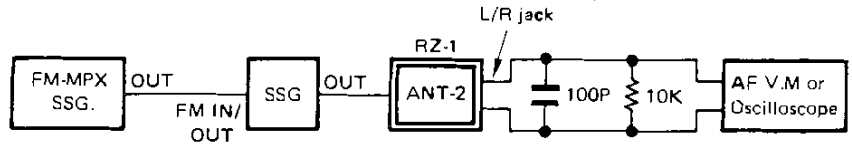

FOR SERVICE MANUALS
CONTACT:
MAURITRON TECHNICAL SERVICES
www.mauritron.co.uk
TEL: 01844 - 351694
FAX: 01844 - 352554

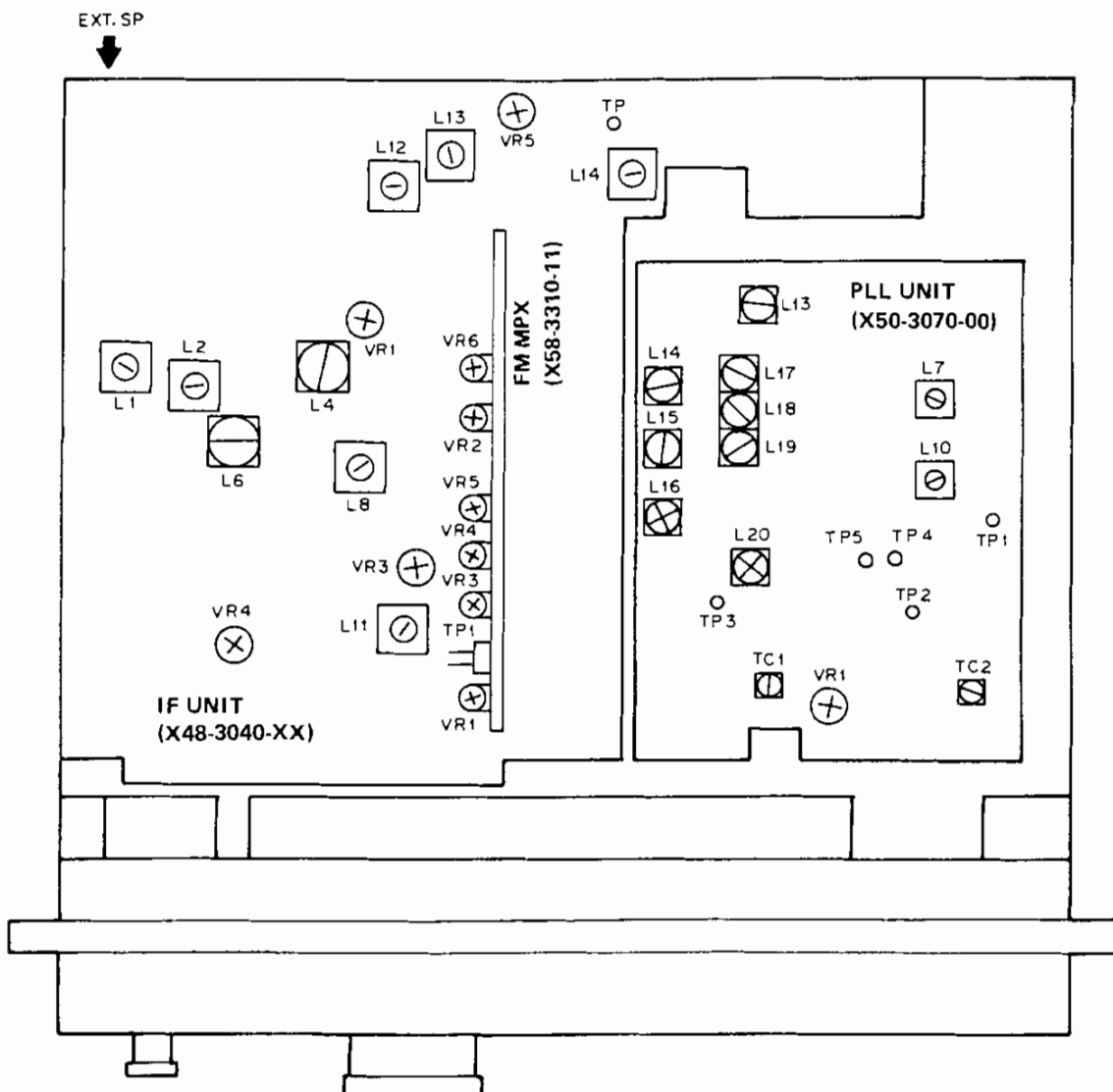

IF UNIT (X48-3040-XX)

- L1, 2, 6, 8 : AM adjustment
- L4 : FM-N descri
- L11 : FM-W descri
- L12~14 : Video adjustment (**K type only**)
- VR1 : FM-N S-meter
- VR3 : AM stop
- VR4 : Beep level.

PLL UNIT (X50-3070-00)

- L7 : 22.250MHz VCO
- L10 : 500kHz VCO
- L13~16 : AM adjustment
- L17~20 : FM-W adjustment
- TC1 : 35.05MHz OSC
- TC2 : 12.6MHz OSC
- VR1 : 35.05MHz adjustment

FM MPX (X58-3310-11)

- VR1 : Soft mute
- VR2 : Separation
- VR3 : FM-W S-meter
- VR4 : FM-W stop
- VR5 : ANRC
- VR6 : Pilot cancelling

RZ-1 PC BOARD VIEWS

DISPLAY UNIT (W02-0811-08)

Component side view

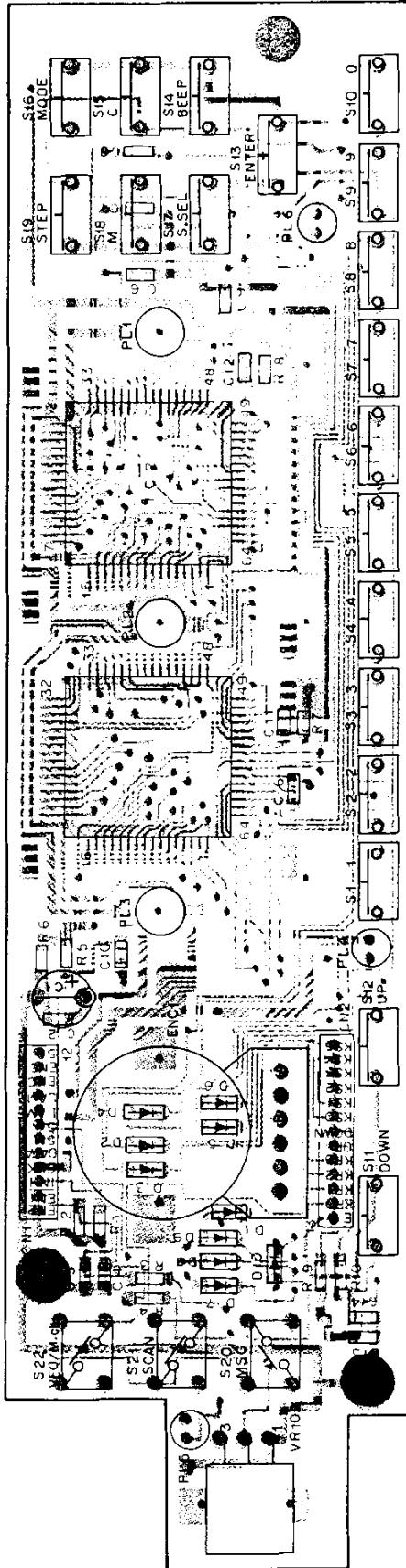

DISPLAY UNIT (W02-0811-08)

Foil side view

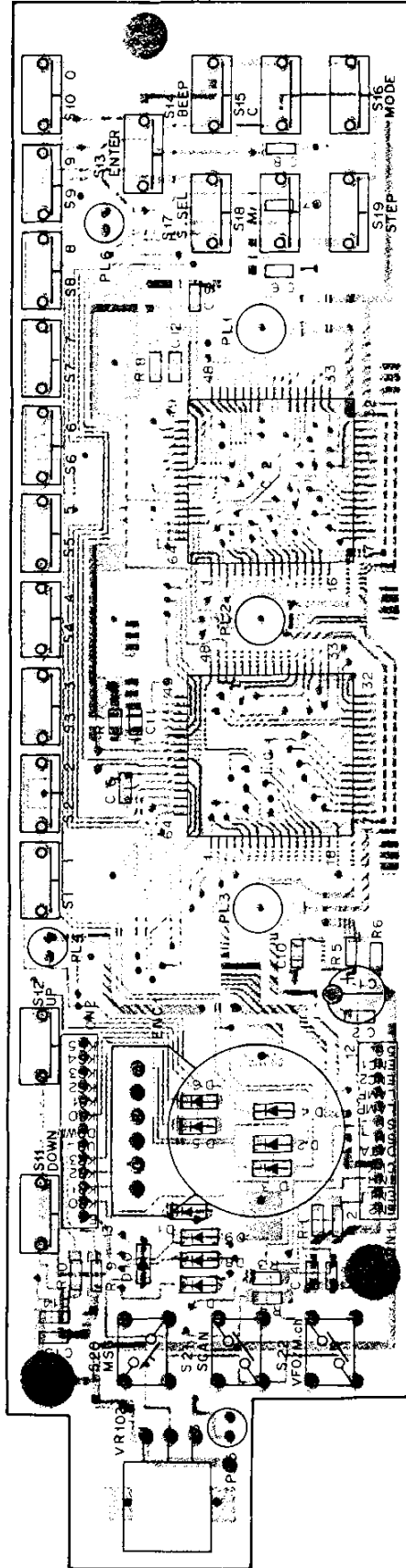

IC1, 2 : LC7582
DI-10 : RLS73

CONTROL UNIT (X53-3110-XX)

11 : K -21 : M -61 : W

Component side view

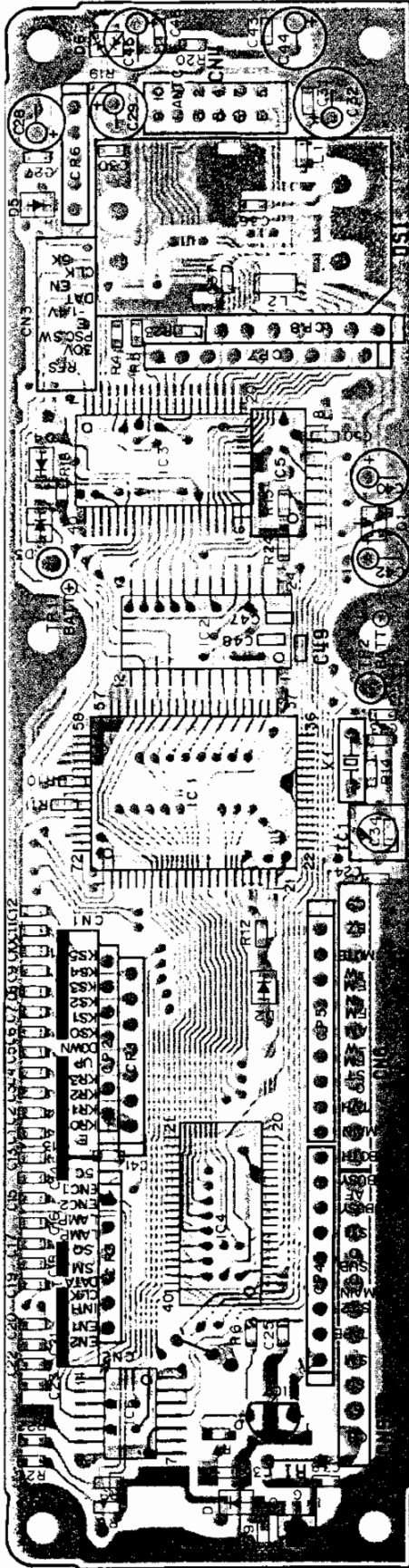

CONTROL UNIT (X53-3110-XX)

-11 : K -21 : M -61 : W

Foil side view

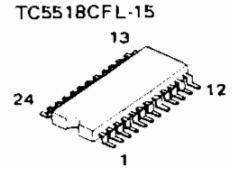
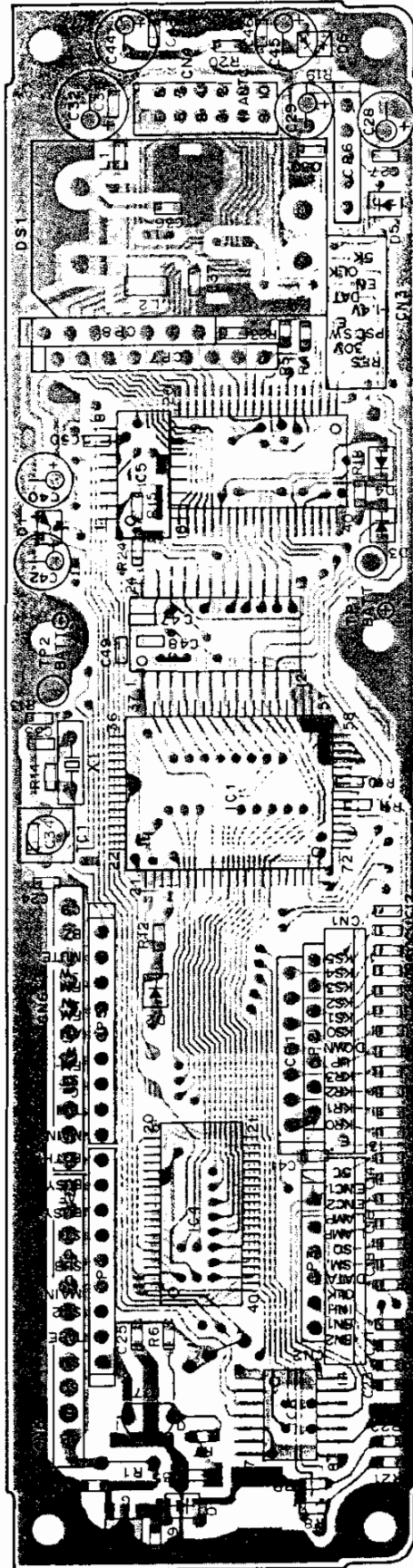

TC74HC139F

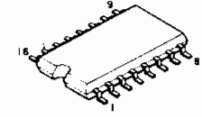

TC74HC14F

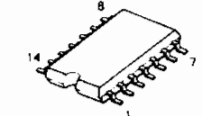

PST523C

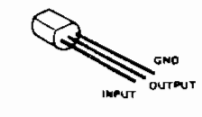

NJM78L06UA

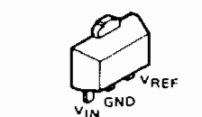

DTC144EK

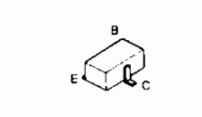

LC7582

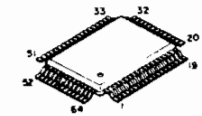

FOR SERVICE MANUALS
CONTACT:
MAURITRON TECHNICAL SERVICE

www.mauritron.co.uk
TEL: 01844 - 351694
FAX: 01844 - 352554

Q1 : DTC144EK IC1 : M50747-744-FP IC2 : TC5518CFL-15 IC3, 4 : MS82C55AFP-5 IC5 : TC74HC139F IC6 : TC74HC14F IC7 : PST523C IC8 : NJM78L06UA
D1-4 : RLS73 D5 : RLZ338 D6 : 1SS226

R21	R22		
K	O	X	O
M	X	O	O
W	O	O	O

O : Used
X : Not used

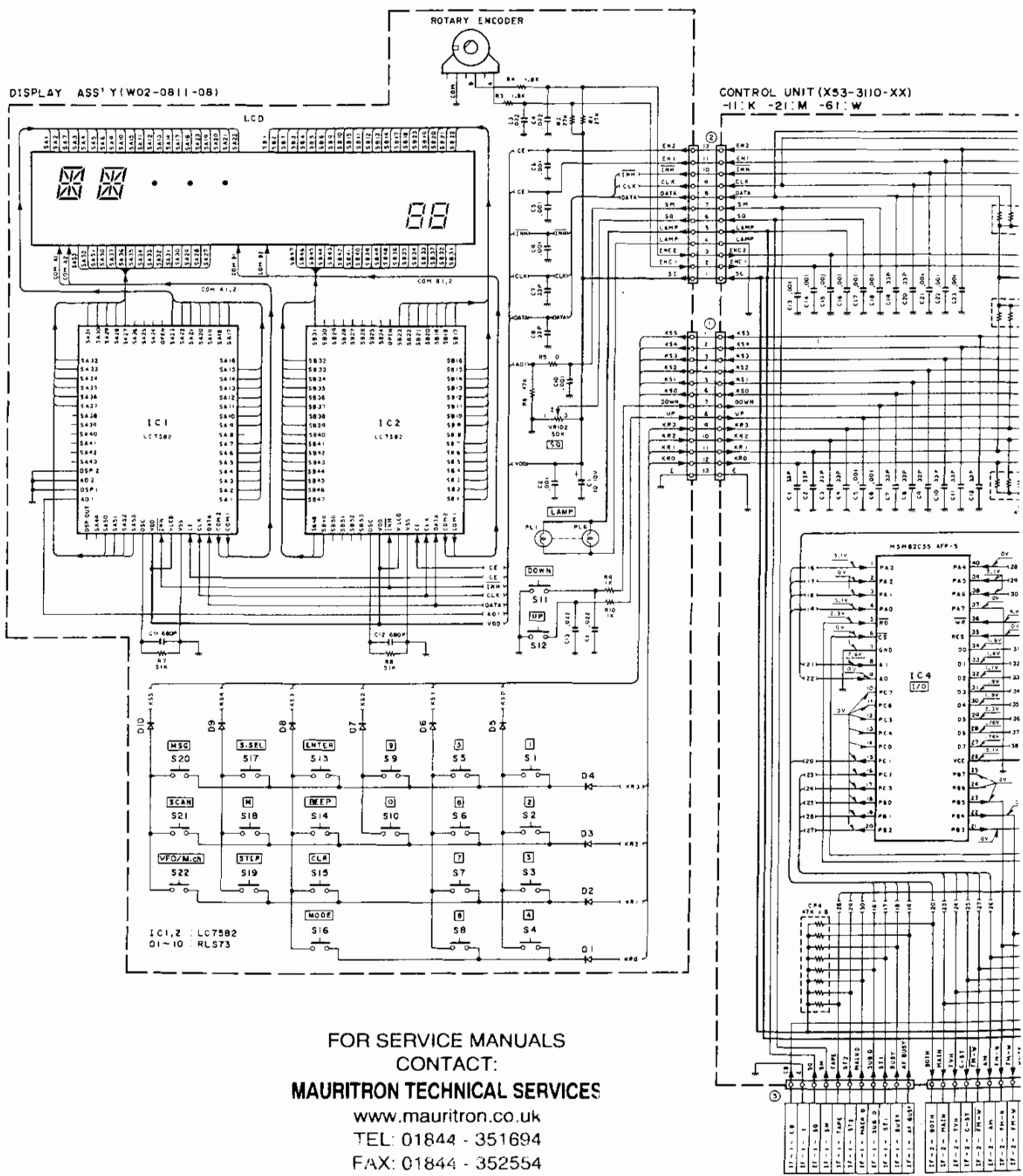

FOR SERVICE MANUALS
CONTACT:
MAURITRON TECHNICAL SERVICES
www.mauritron.co.uk
TEL: 01844 - 351694
FAX: 01844 - 352554

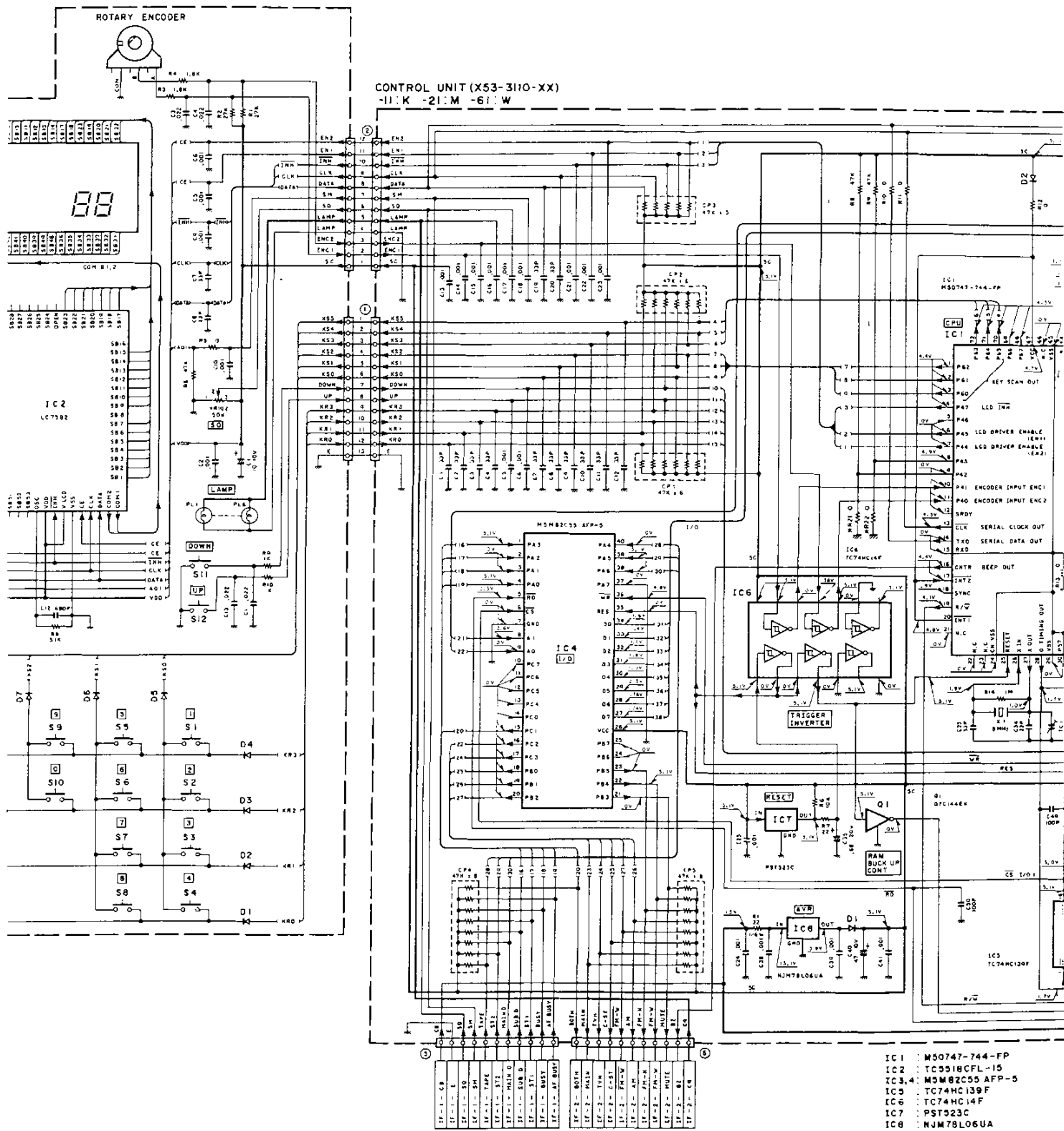

CIRCUIT DIAGRAM RZ-1

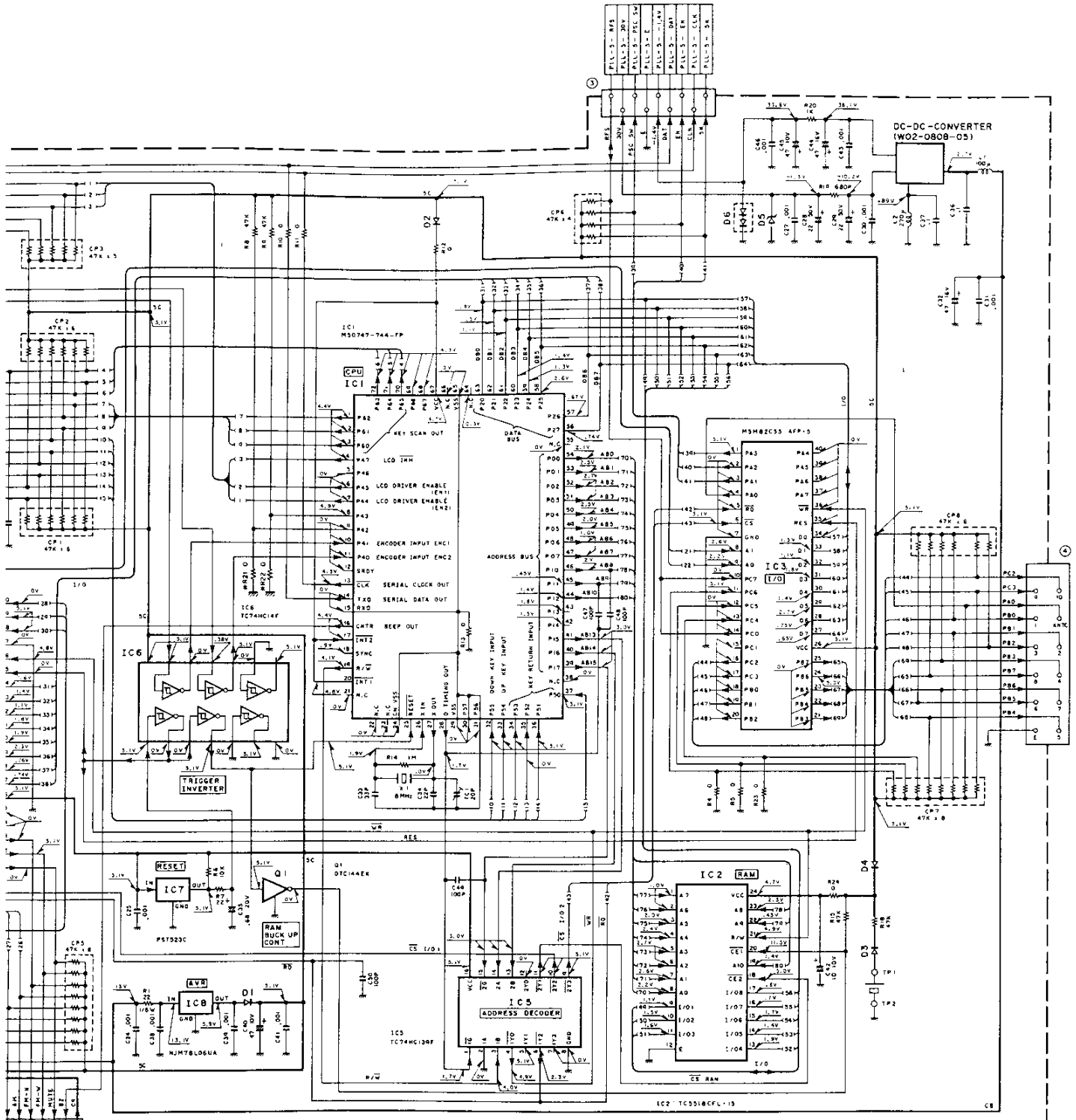

IC1 : M50747-744-FP Q1 : DTC144EK
 IC2 : TC5518CFL-15 D1 ~ 4 : RL573
 IC3,4 : MSM82C55 AFP-3 D5 : RLZ33B
 IC5 : TC74HC139F D6 : ISS226
 IC6 : TC74HC14F
 IC7 : PST523C
 IC8 : NJM78L06UA

R21	R22
✓	USED
✗	NOT USED
✗	USED
✗	USED

FOR SERVICE MANUALS
CONTACT:

MAURITRON TECHNICAL SERVICES

www.mauritron.co.uk
 TEL: 01844 - 351694
 FAX: 01844 - 352554

RZ-1 PC BOARD VIEWS/CIRCUIT DIAGRAM

SUB UNIT (X58-3310-11)

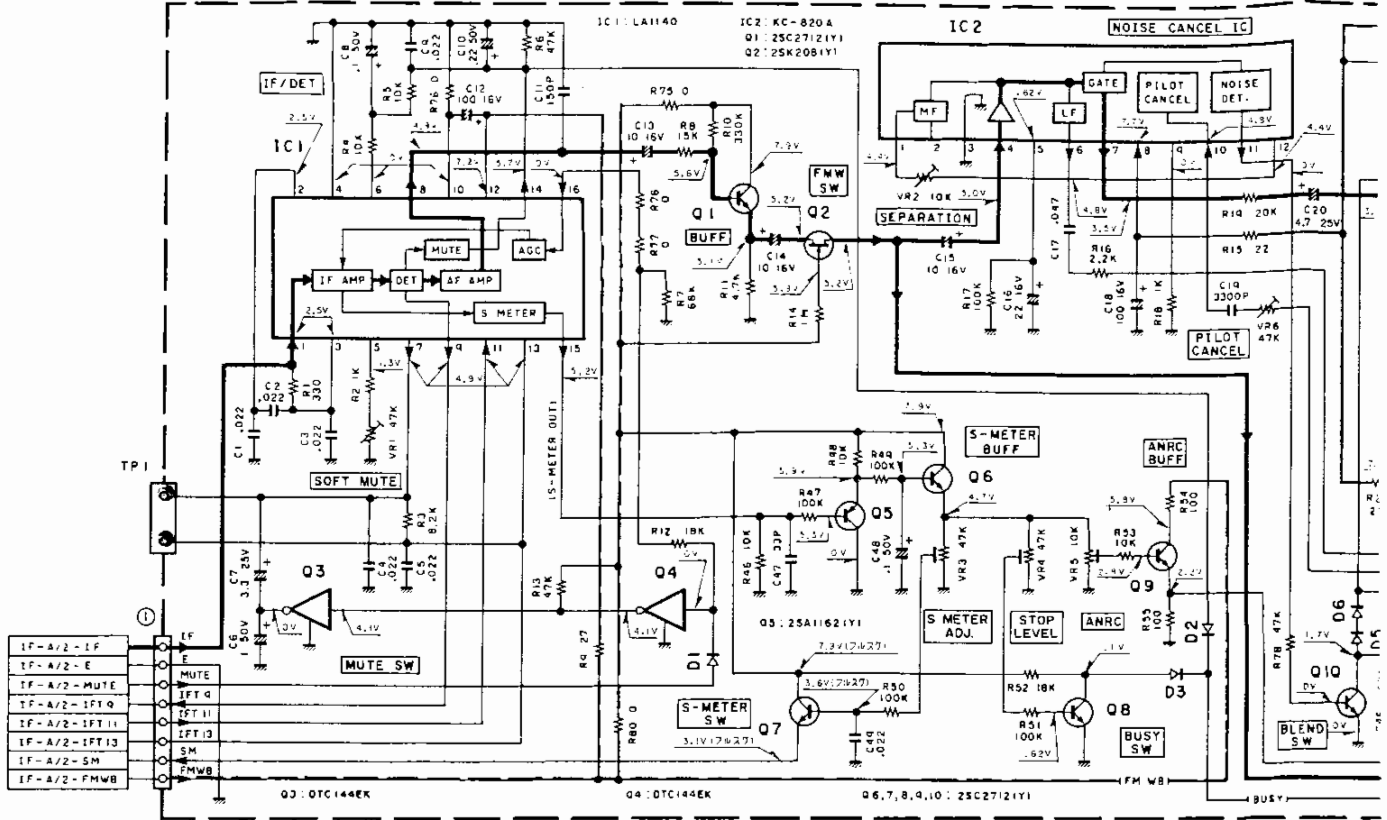

FM MPX (X58-3310-11) Component side view

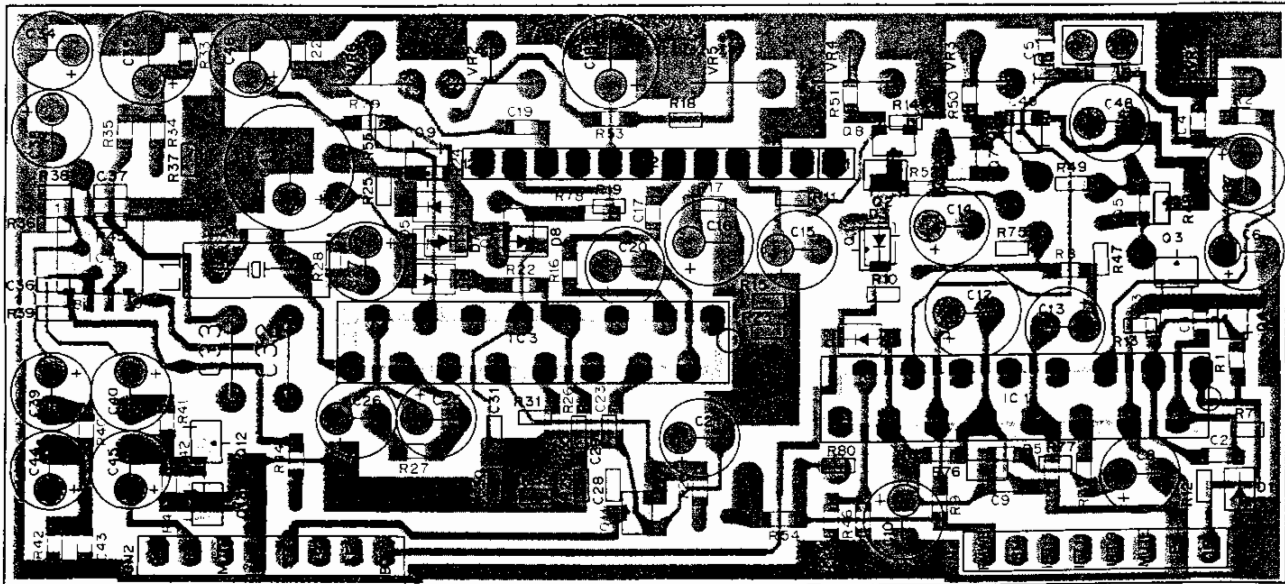

Q1, 6-10: 2SC2712(Y) Q2: 2SK208(Y) Q3, 4, 11: DTC144EK Q5: 2SA1162(Y) Q12, 13: 2SD1757(K)
 IC1: LA1140 IC2: KC-820A IC3: LA3430 IC4: NJM4558M
 D1-8: RLS73

FOR SERVICE MANUALS
 CONTACT:
MAURITRON TECHNICAL SERVICES

www.mauritron.co.uk
 TEL: 01844 - 351694
 FAX: 01844 - 352554

EWS/CIRCUIT DIAGRAM

- 11)

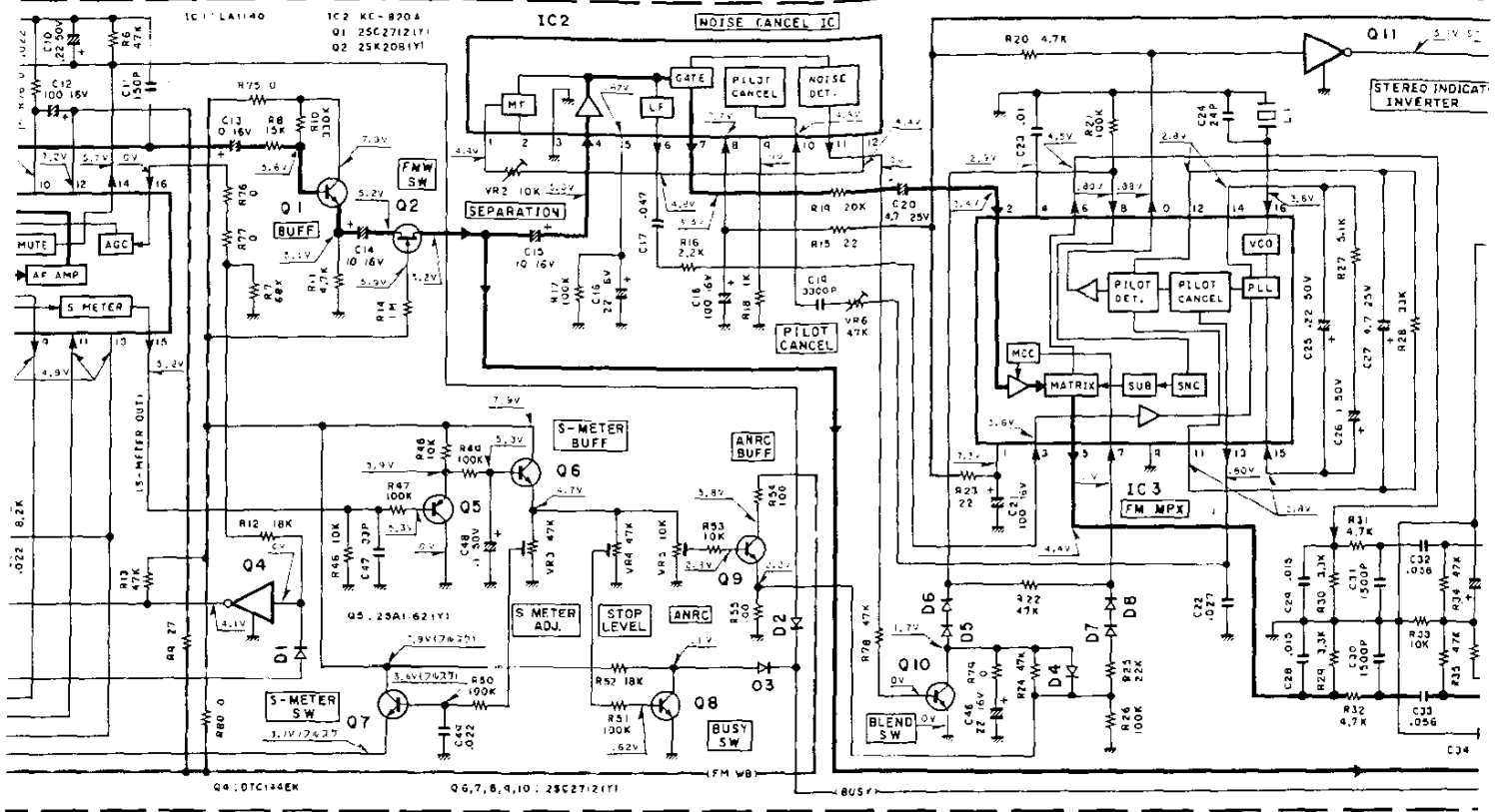

de view

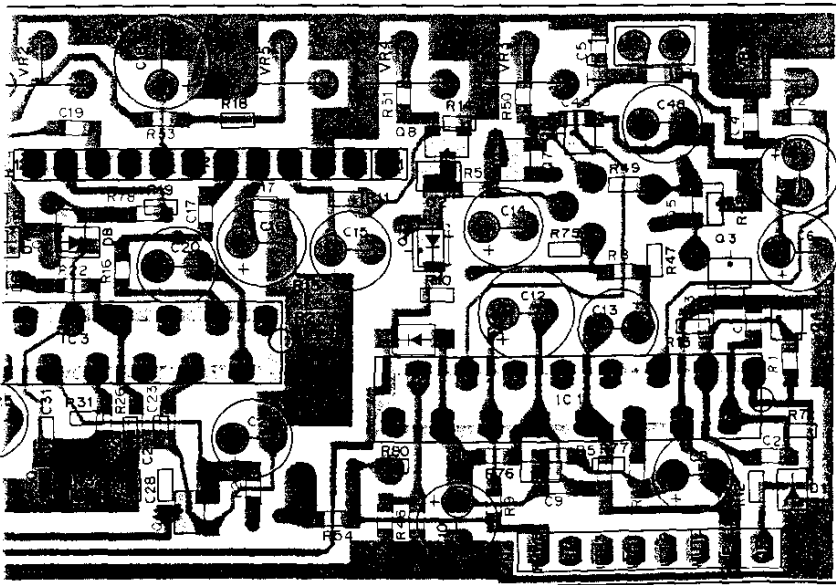

FM MPX (X58-3310-11) Foil side view

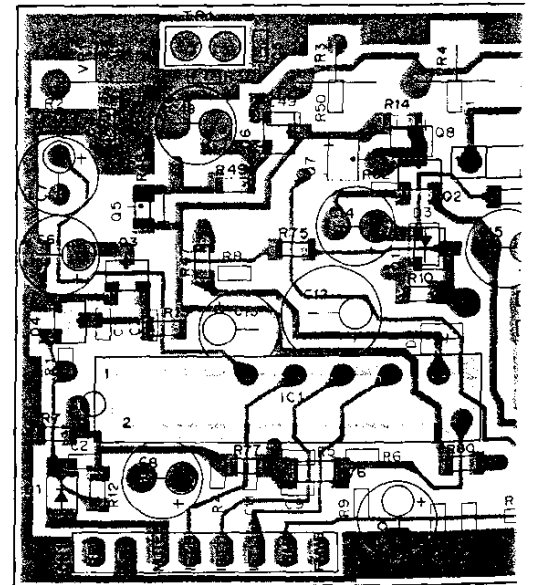

I, 11 : DTC144EK Q5 : 2SA1162(Y) Q12, 13 : 2SD1757(K)
C4 : NJM4558M

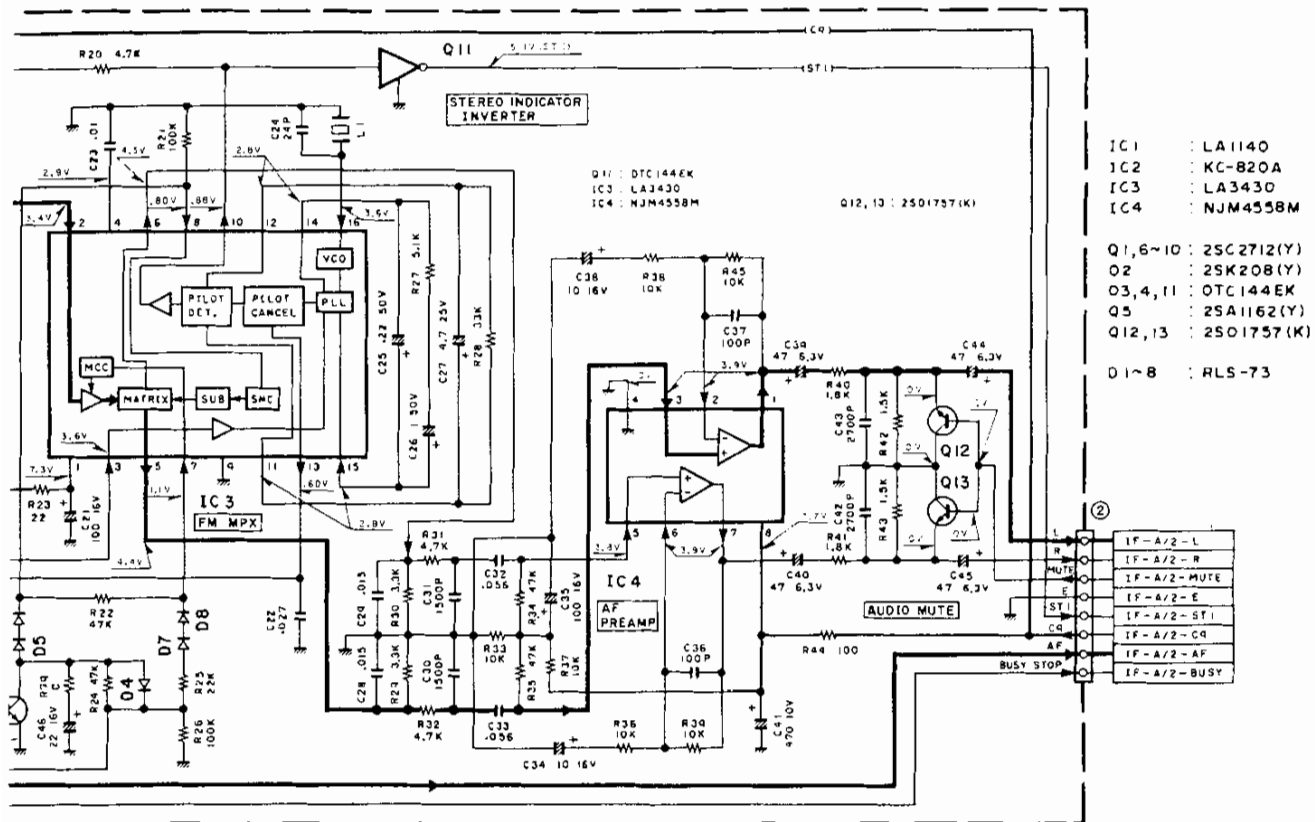

FM MPX (X58-3310-11) Foil side view

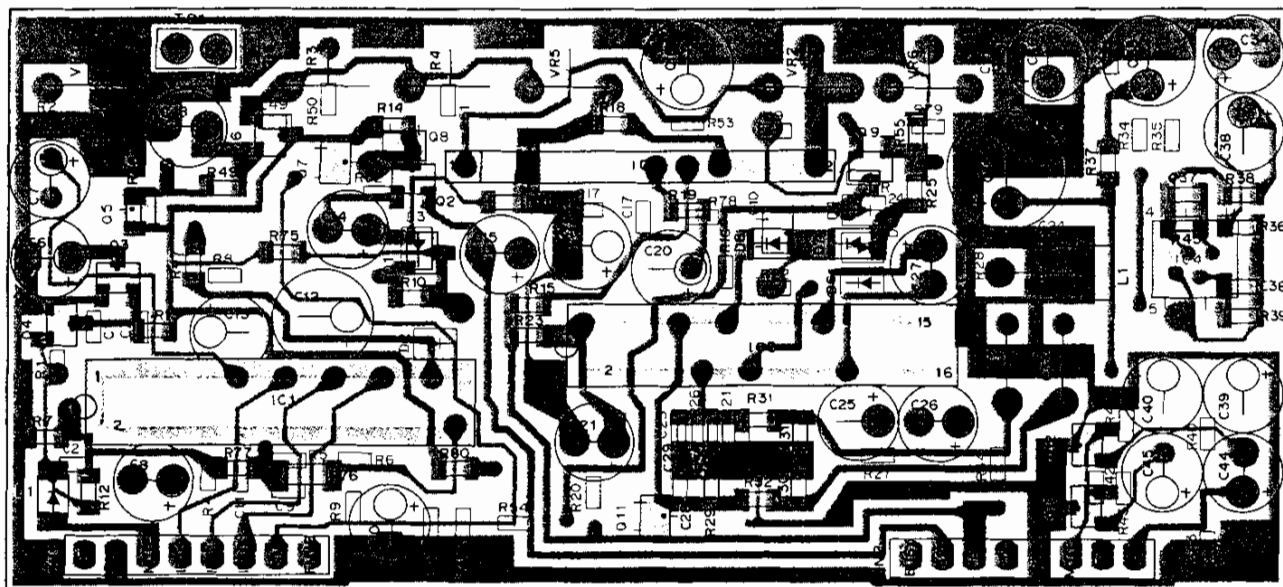

FOR SERVICE MANUALS
 CONTACT:
MAURITRON TECHNICAL SERVICES
 www.mauritron.co.uk
 TEL: 01844 - 351694
 FAX: 01844 - 352554

PC BOARD VIEWS RZ-1

IF (X59-3140-00) Component side view

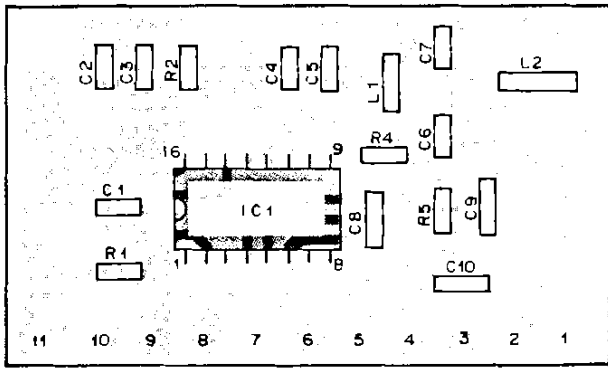

IC1 : TA7761F

SM (X59-3380-00) Component side view

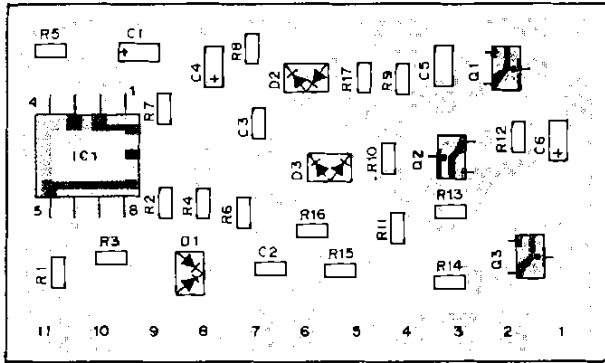

Q1 : 2SC2712(Y) Q2,3 : 2SC3295(B)
 IC1 : NJM4558M
 D1 : 1SS184 D3 : 1SS181

SQL (X59-3150-00) Component side view

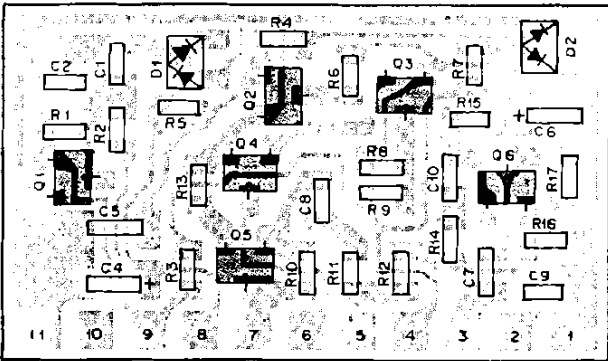

Q1,2,5,6 : 2SC2712(Y) Q3,4 : 2SC3295(B)
 D1 : 1SS226 D2 : 1SS181

FOR SERVICE MANUALS
 CONTACT:
MAURITRON TECHNICAL SERVICES
www.mauritron.co.uk
 TEL: 01844 - 351694
 FAX: 01844 - 352554

LA1140
 LA3430

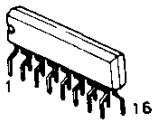

KC-820A

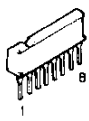

NJM4558M

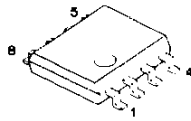

2SA1162(Y)
 2SC2712(Y)
 2SC3295(B)
 2SD1757(K)
 DTC144EK



2SK208(Y)



TA7761F

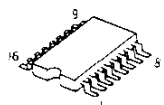

RZ-1 PC BOARD VIEWS

IF UNIT (X48-3040-XX) -11 : K -21 : M, W Component side view

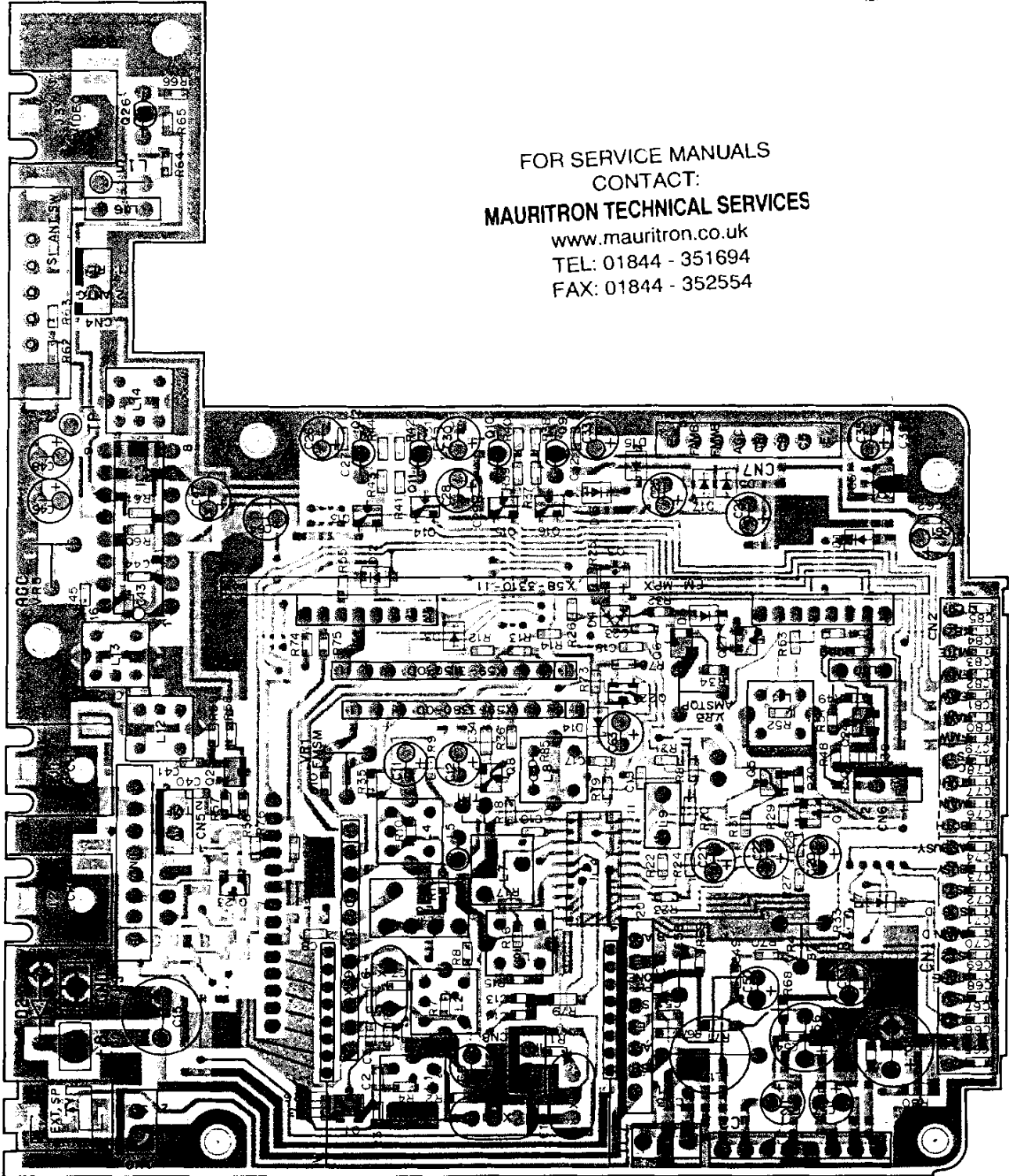

FOR SERVICE MANUALS
CONTACT:
MAURITRON TECHNICAL SERVICES
www.mauritron.co.uk
TEL: 01844 - 351694
FAX: 01844 - 352554

Q1, 24, 25 : 2SC2714(Y) Q3, 5, 6 : 2SC2712(Y) Q4 : 2SA1162(Y) Q8, 22 : 2SK208(Y)
Q9-12 : 2SB698 Q13-16, 23, 27 : DTC144EK Q26 : 2SC1959(Y)
IC1 : MC7808C or UA7808 IC2 : μ PC1242H IC3 : LA7505
IC4 : LA1135M IC5 : NJM78L05UA
D1, 3, 5-7, 12, 14-17 : RLS-73 D2 : DSM1A1 D4 : 1SS226

NJM78L05UA

2SA1162(Y)
2SC2712(Y)
2SC2714(Y)
DTC144EK

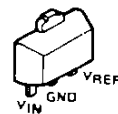

PC BOARD VIEWS RZ-1

IF UNIT (X48-3040-XX) -11 : K -21 : M, W Foil side view

FOR SERVICE MANUALS
CONTACT:
MAURITRON TECHNICAL SERVICES
www.mauritron.co.uk
TEL: 01844 - 351694
FAX: 01844 - 352554

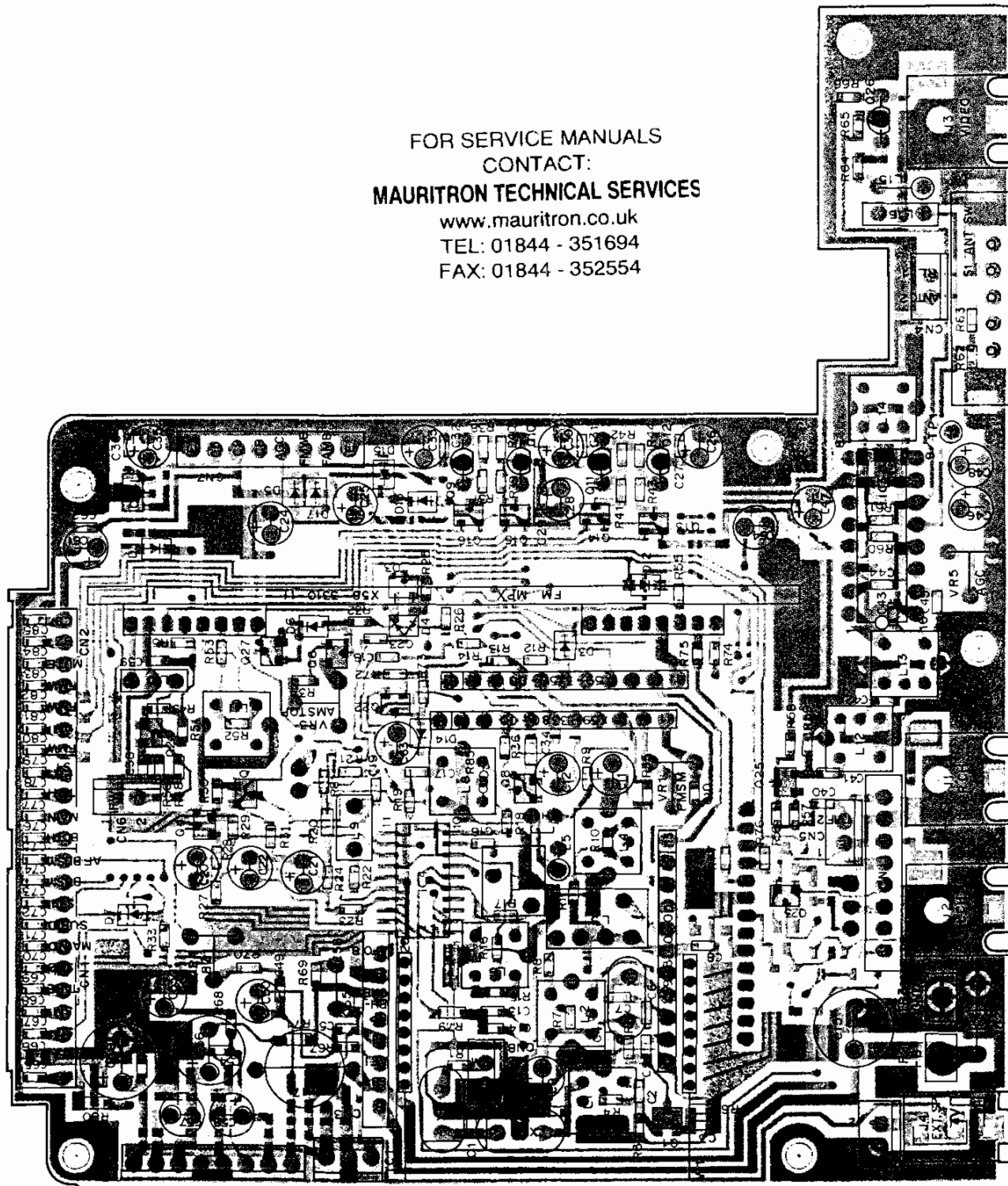

MC7808C

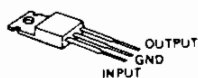

μPC1242H

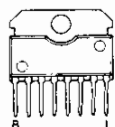

LA7505

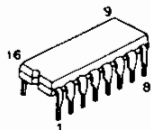

LA1135M

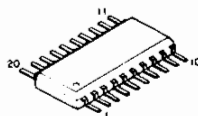

2SK208(Y)



2SB698
2SC1959(Y)

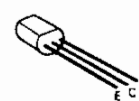

RZ-1 PC BOARD VIEWS

PLL UNIT (X50-3070-00) Component side view

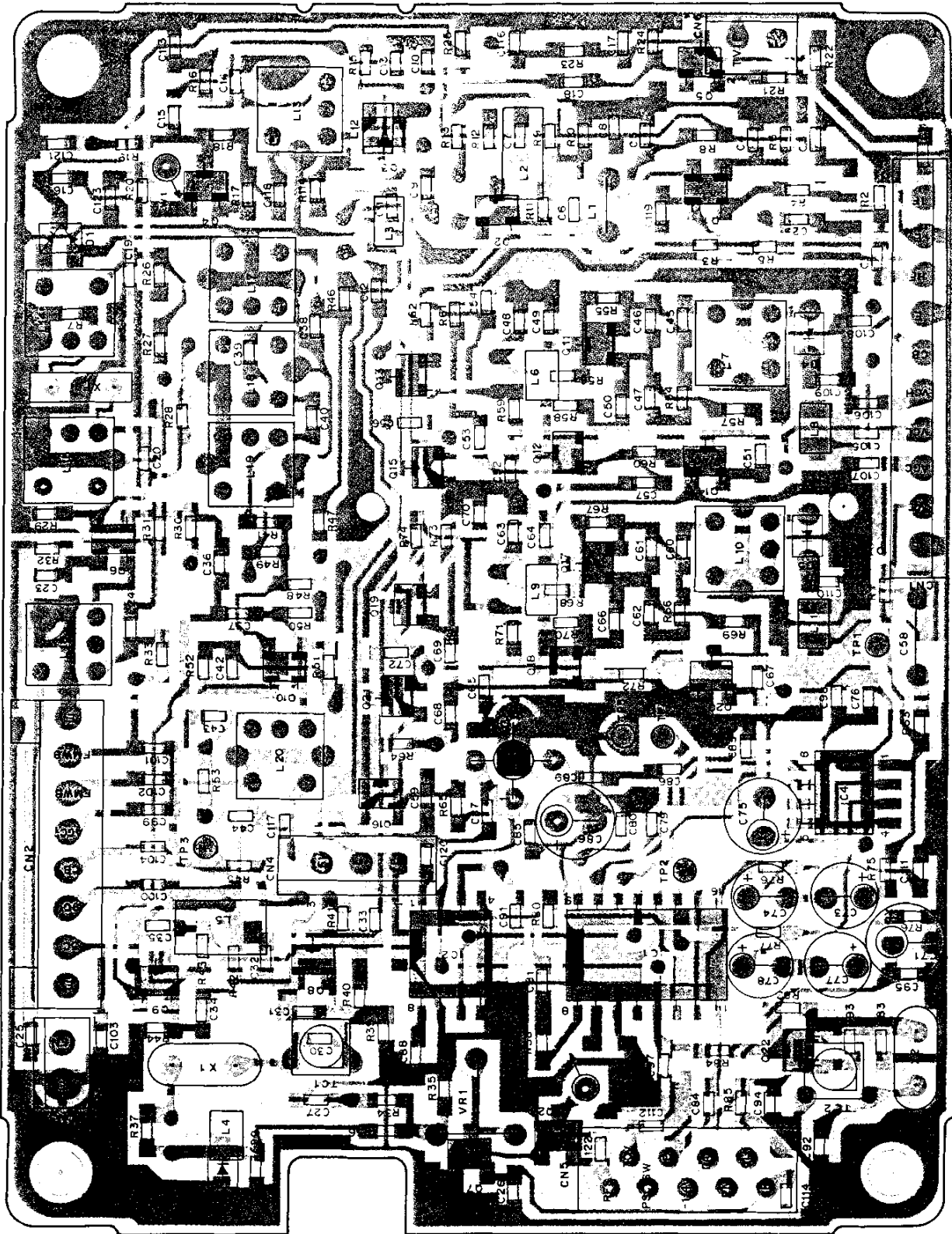

M887006APF

M8501PF
NJM4558M

μ PC1651G

3SK131(K)

2SC2714(Y)
DTC114EK
DTC144EK

2SK302(Y)

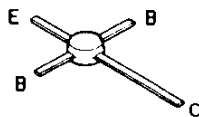
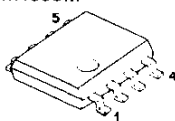
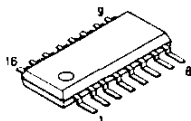

PC BOARD VIEWS RZ-1

PLL UNIT (X50-3070-00) Foil side view

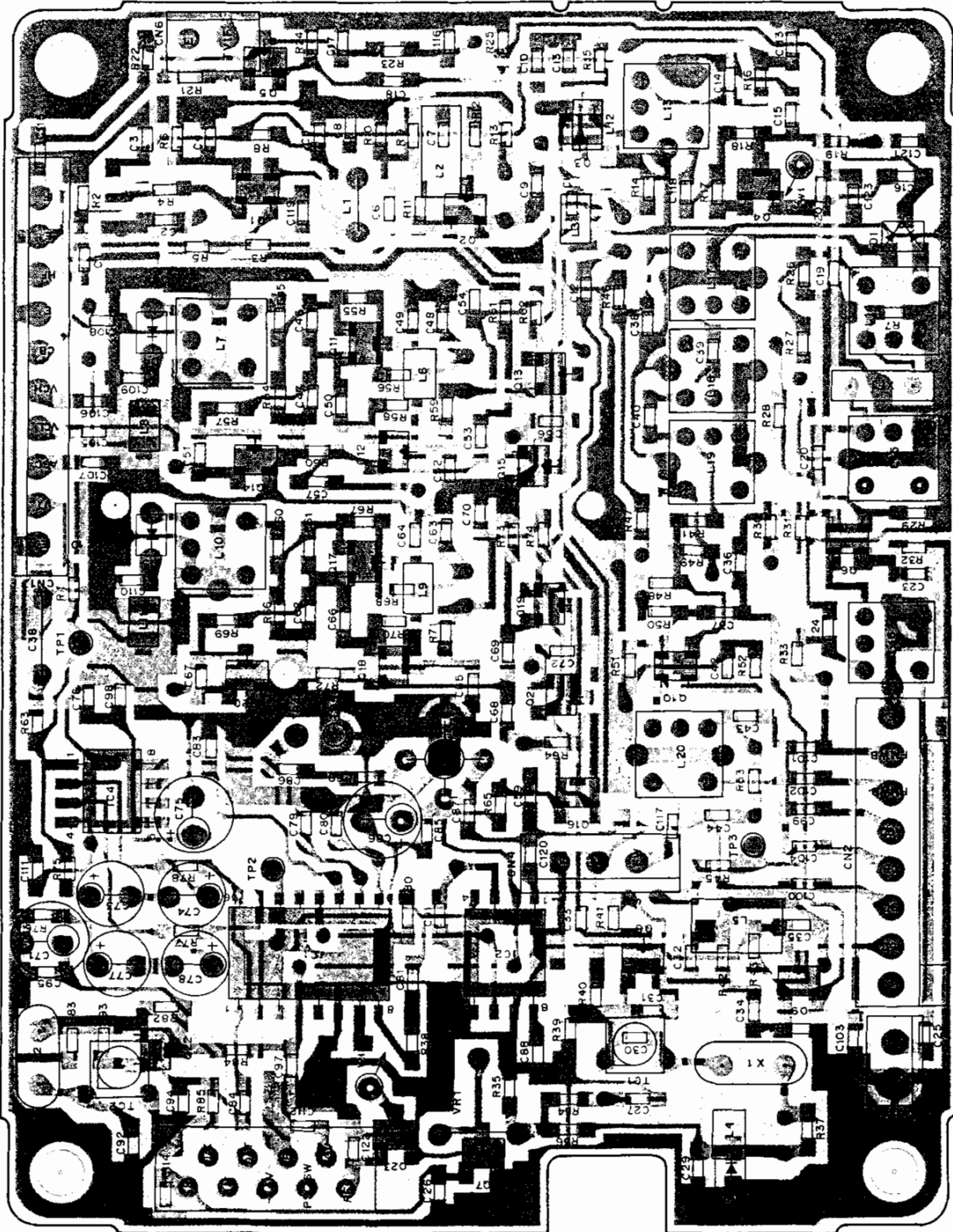

Q1, 6, 10 : 3SK131(K) Q2, 4, 5, 8, 9, 11, 12, 17, 18, 22 : 2SC2714(Y) Q3, 13, 16, 19 : 2SK302(Y)
Q7, 14, 15, 20, 21 : DTC114EK Q23 : DTC144EK
IC1 : MB87006APF IC2 : MB501PF IC3 : μ PC1651G IC4 : NJM4558M
D1 : DAN235(K) D2, 3, 5 : 1SV166

FOR SERVICE MANUALS
CONTACT:

MAURITRON TECHNICAL SERVICES

www.mauritron.co.uk

TEL: 01844 - 351694

FAX: 01844 - 352554

RZ-1 PC BOARD VIEWS

RF UNIT (X44-3050-00)

Component side view

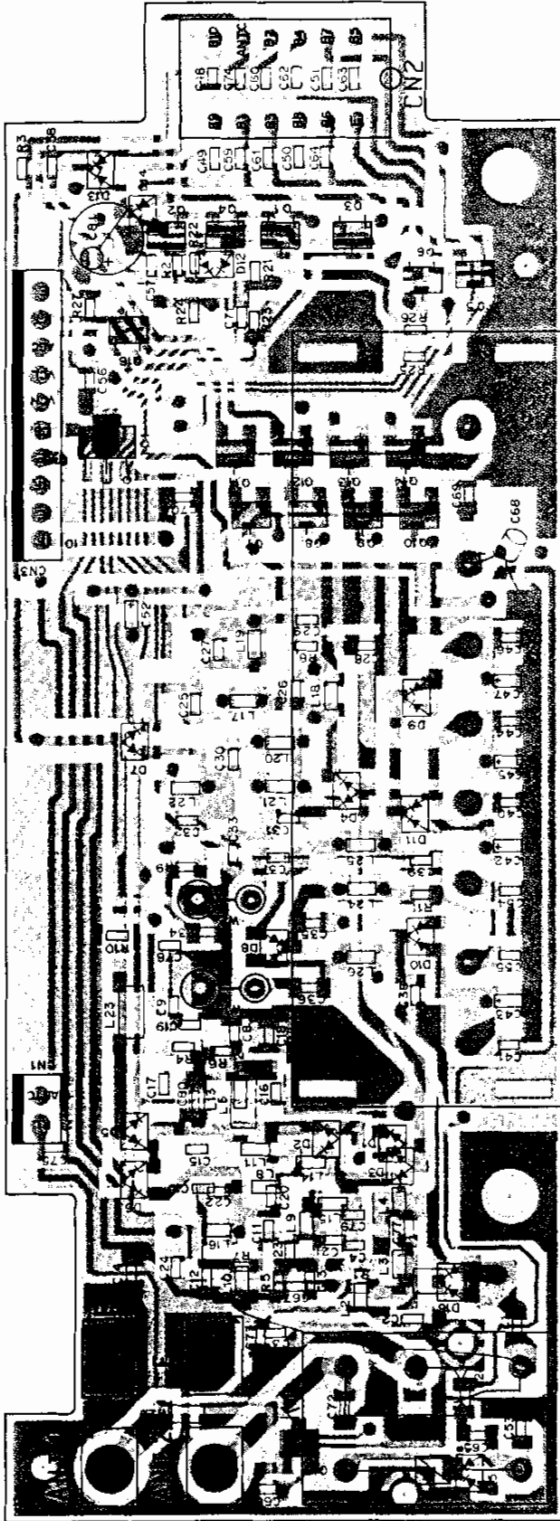

RF UNIT (X44-3050-00)

Foil side view

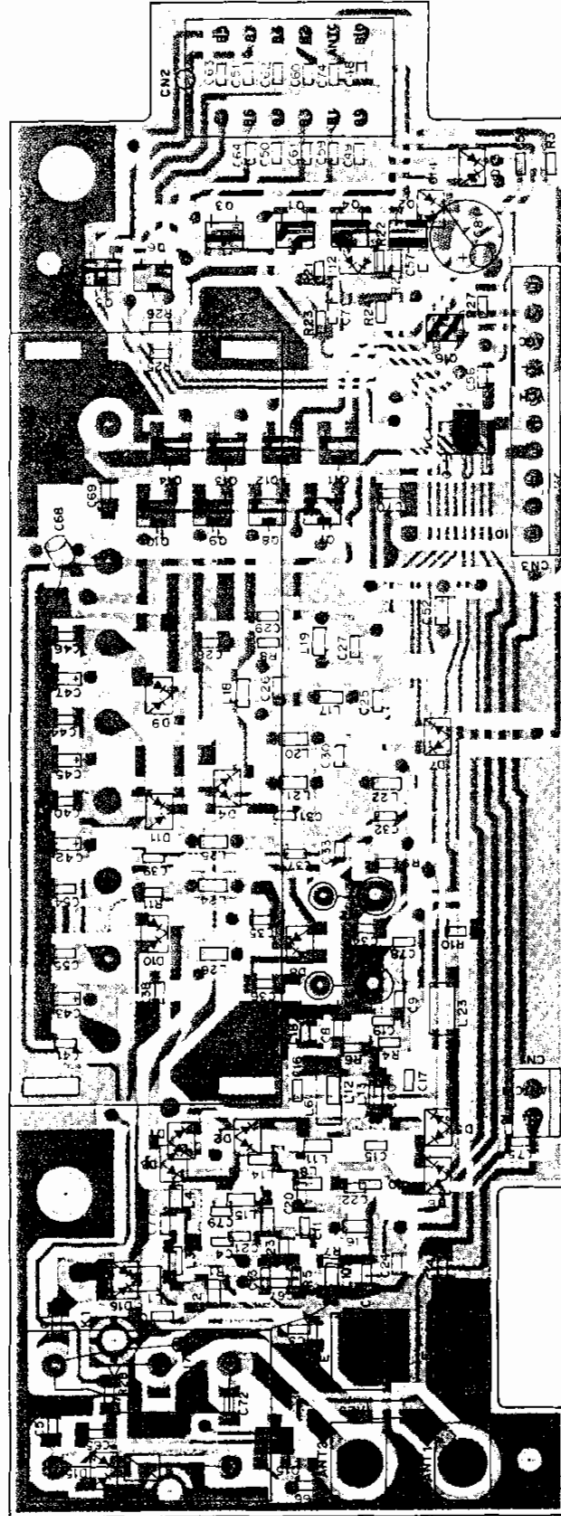

Q1-6,11-14 : DTC114EK Q7-10 : DTB123EK Q15 : DTD114EK Q16 : 2SC2712(Y)
 IC1 : TA78L09F
 D1-7 : DAP236(K) D8 : DAN235(K) D9-15 : DAN202(K) Q17 : DSP-301N

TA78L09F



2SC2712(Y)
 DTB123EK
 DTC114EK
 DTC144EK



FOR SERVICE MANUALS
 CONTACT:
MAURITRON TECHNICAL SERVICES
www.mauritron.co.uk
 TEL: 01844 - 351694
 FAX: 01844 - 352554

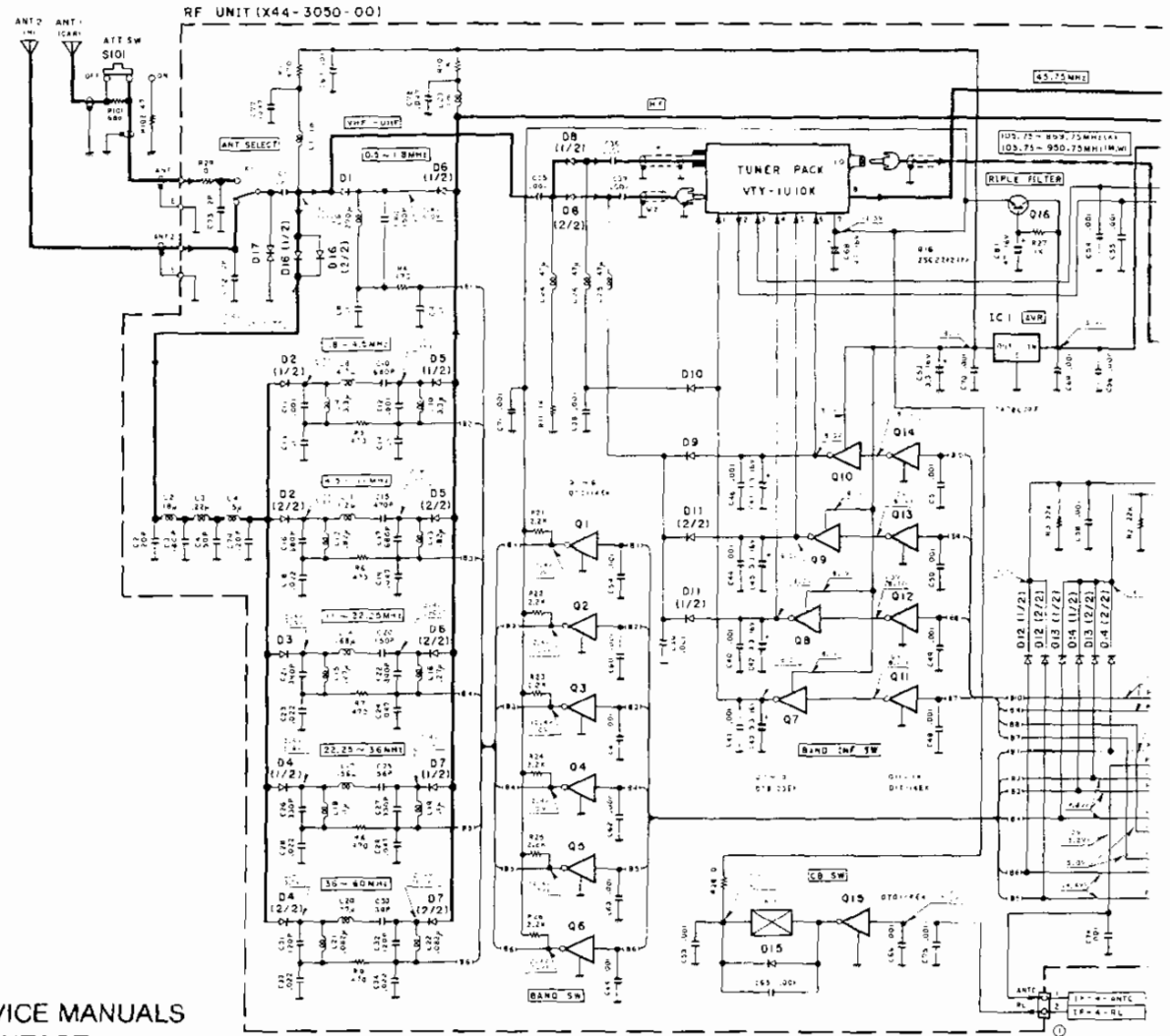

FOR SERVICE MANUALS
 CONTACT:
MAURITRON TECHNICAL SERVICES
 www.mauritron.co.uk
 TEL: 01844 - 351694
 FAX: 01844 - 352554

- | | | |
|----------------|------------------------|------------------|
| IC1 : TA7BLQ9F | Q1-6, 11-14 : DTC114EK | Q1-7 : DAP236K |
| | Q7-10 : DTB123EK | Q8, 15 : DAN235K |
| | Q15 : DTQ114EK | Q9-13 : DAN202K |
| | Q16 : 25C2712 (Y) | Q17 : D5P-3Q1W |

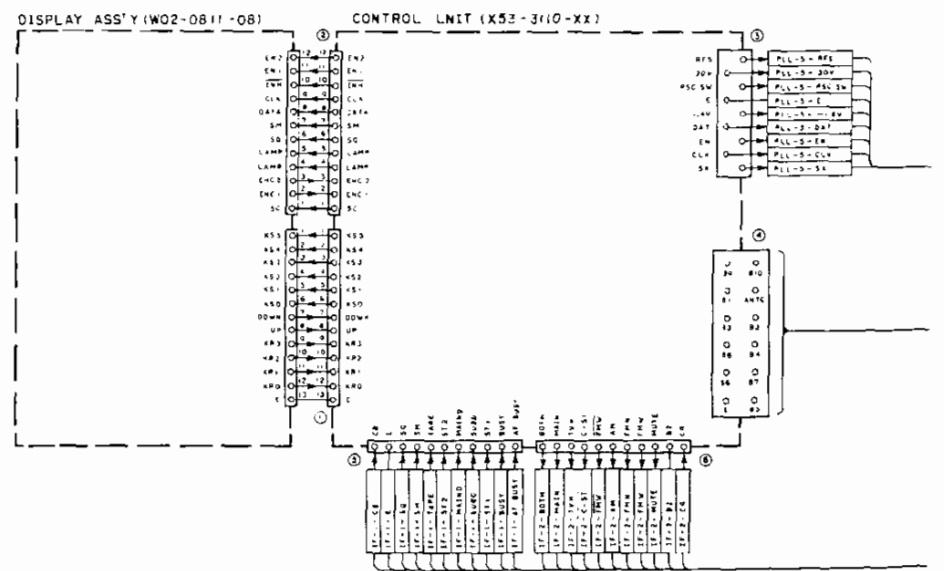

e --- Control line --- Common DC line

UNIT (X44-3050-00)

PLL UNIT (X50-3070-00)

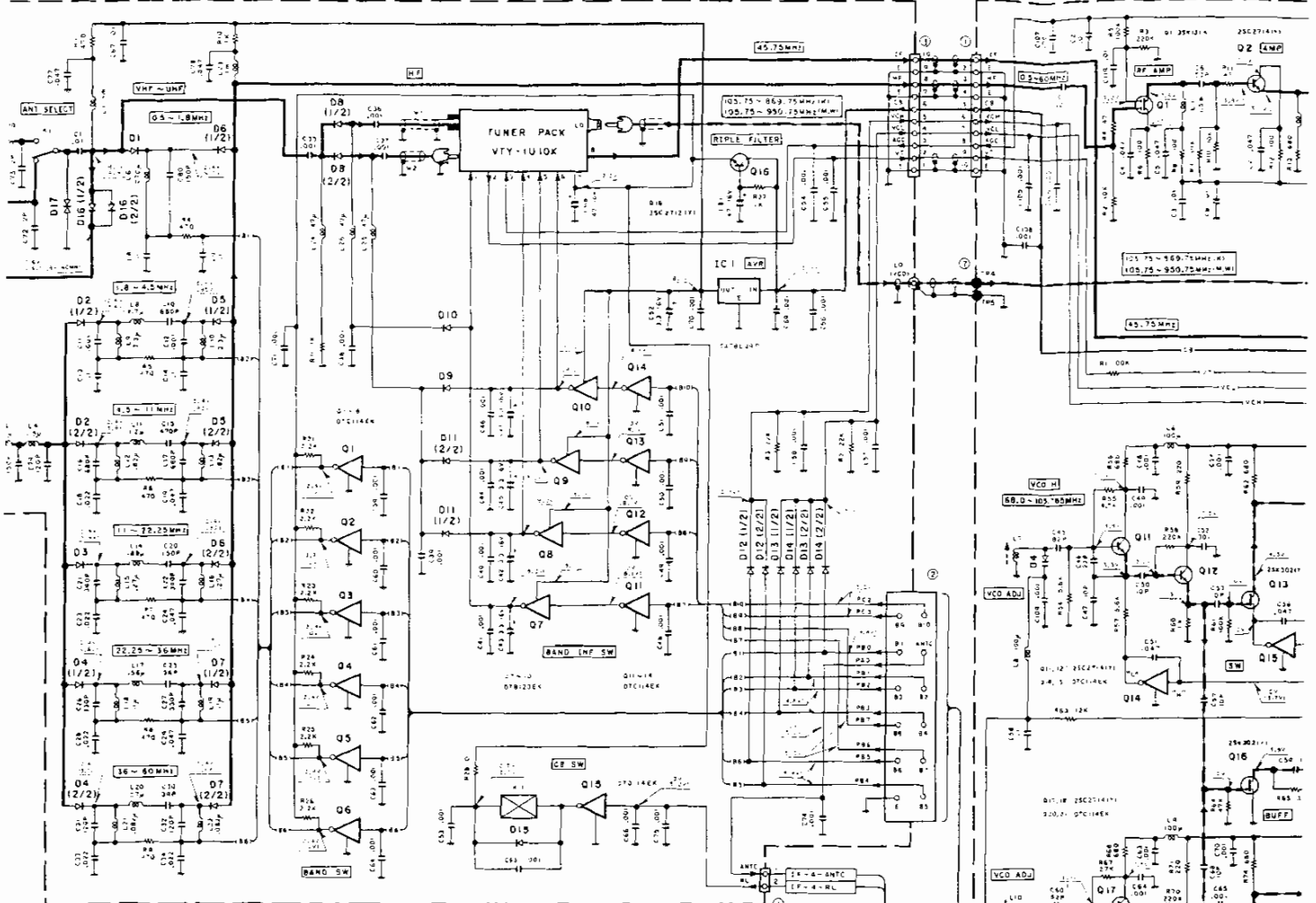

IC1: T478L09F

Q1 - Q11: DTC144EK
 Q7 - Q8: DTC123EK
 Q15: DTC1144EK
 Q16: 2SC2712 (Y)

D1 - D7: DAP236K
 D9, 16: DAN238K
 D9 - D15: DAN202 K
 D17: DSP-301N

DISPLAY ASS'Y (W02-0811-08)

CONTROL UNIT (X53-3110-XX)

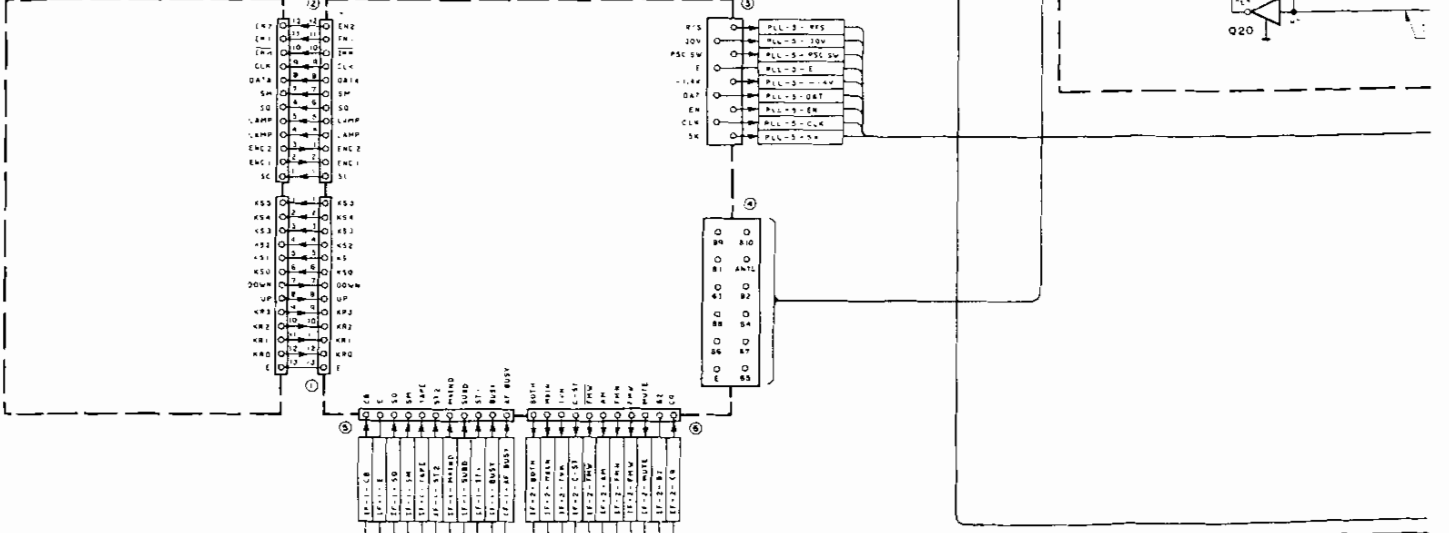

SCHEMATIC

PLL UNIT (X50-3070-00)

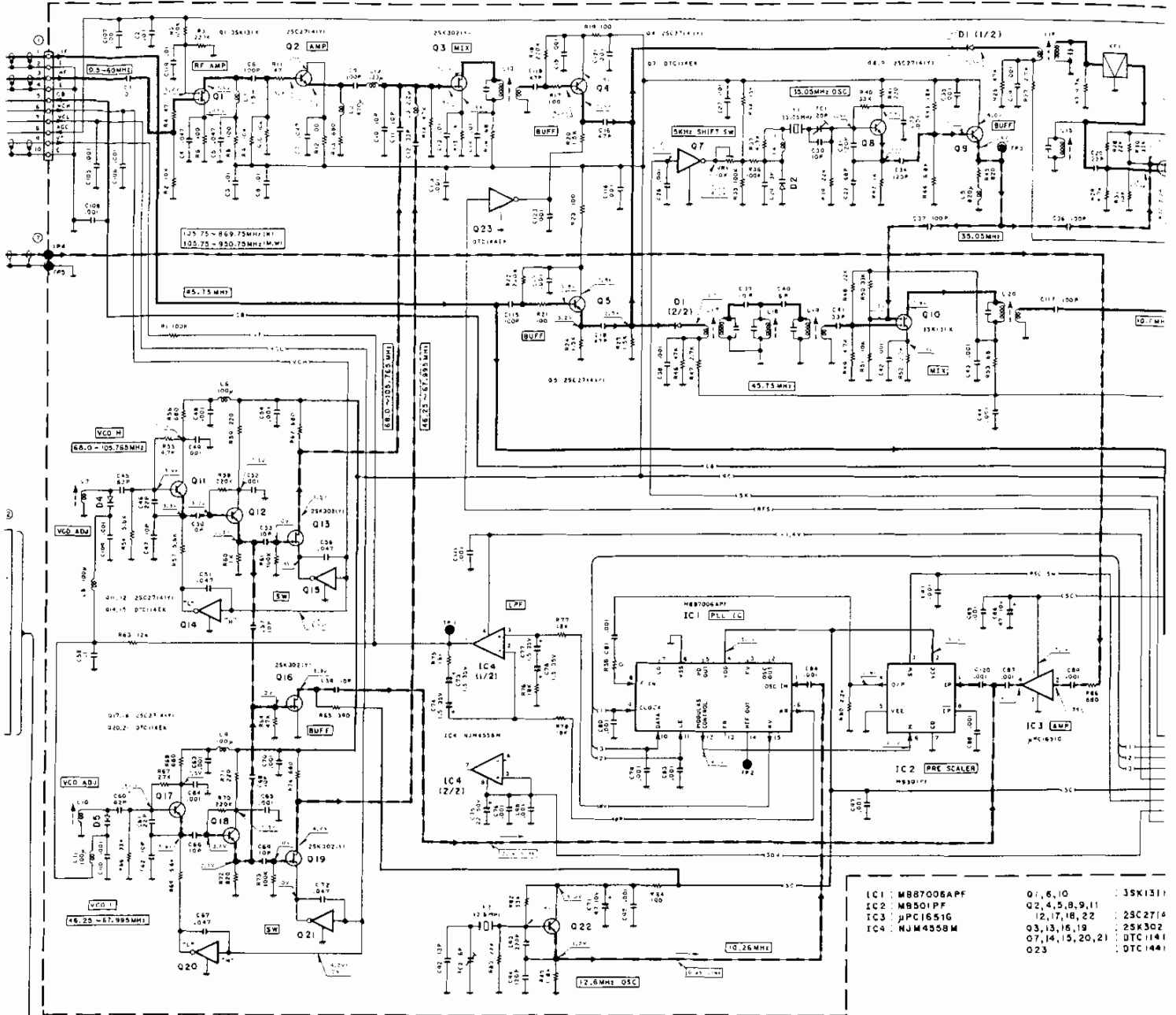

- | | | |
|------------------|--------------------|---------|
| IC1 : MB87006APF | Q1, 6, 10 | 35K1311 |
| IC2 : MB501PF | Q2, 4, 5, 8, 9, 11 | 25C2714 |
| IC3 : JPC1651G | 12, 17, 18, 22 | 25K302 |
| IC4 : NJM4558M | Q3, 13, 16, 19 | QTC1141 |
| | Q7, 14, 15, 20, 21 | QTC1441 |
| | Q23 | QTC1441 |

SCHEMATIC DIAGRAM

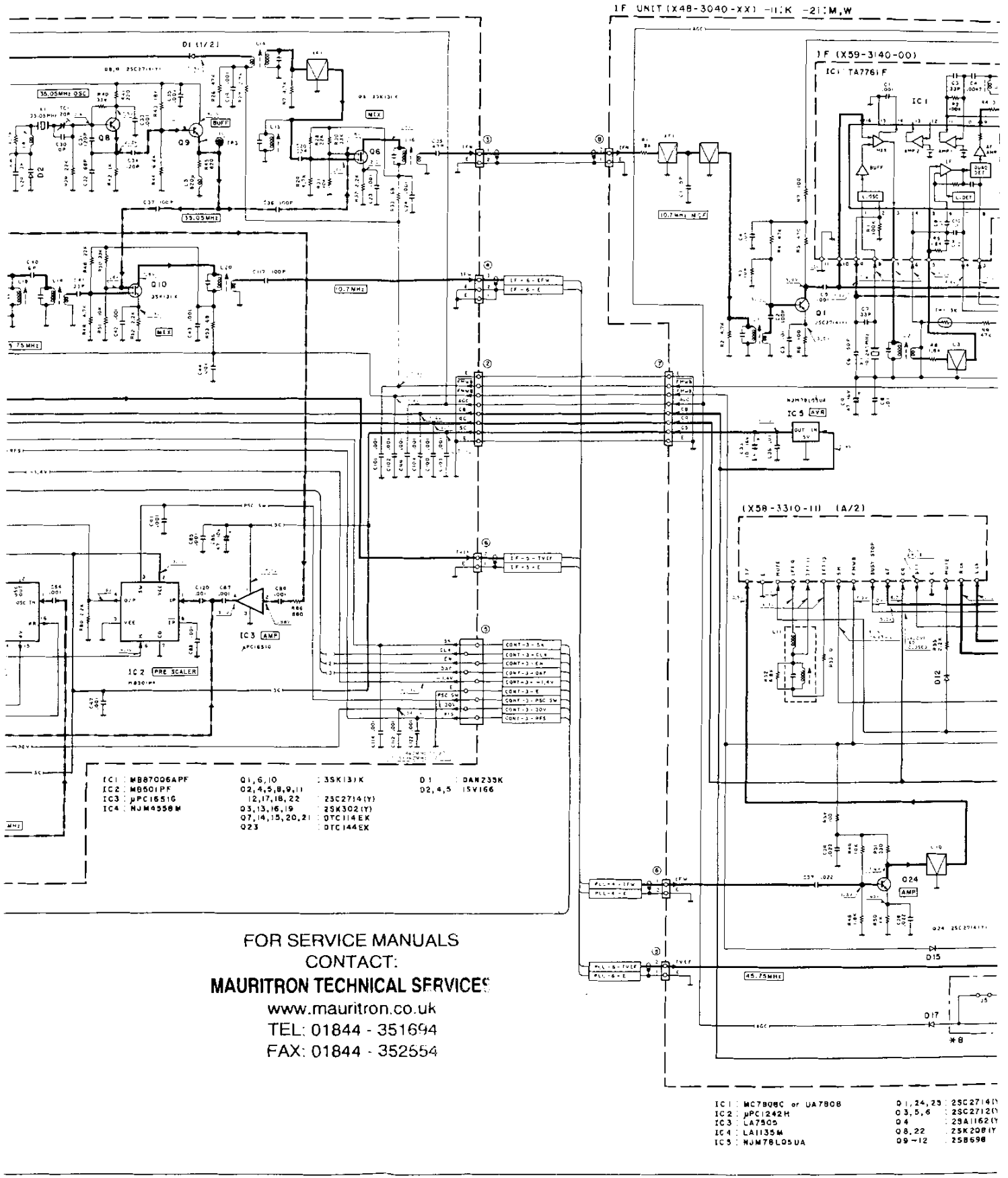

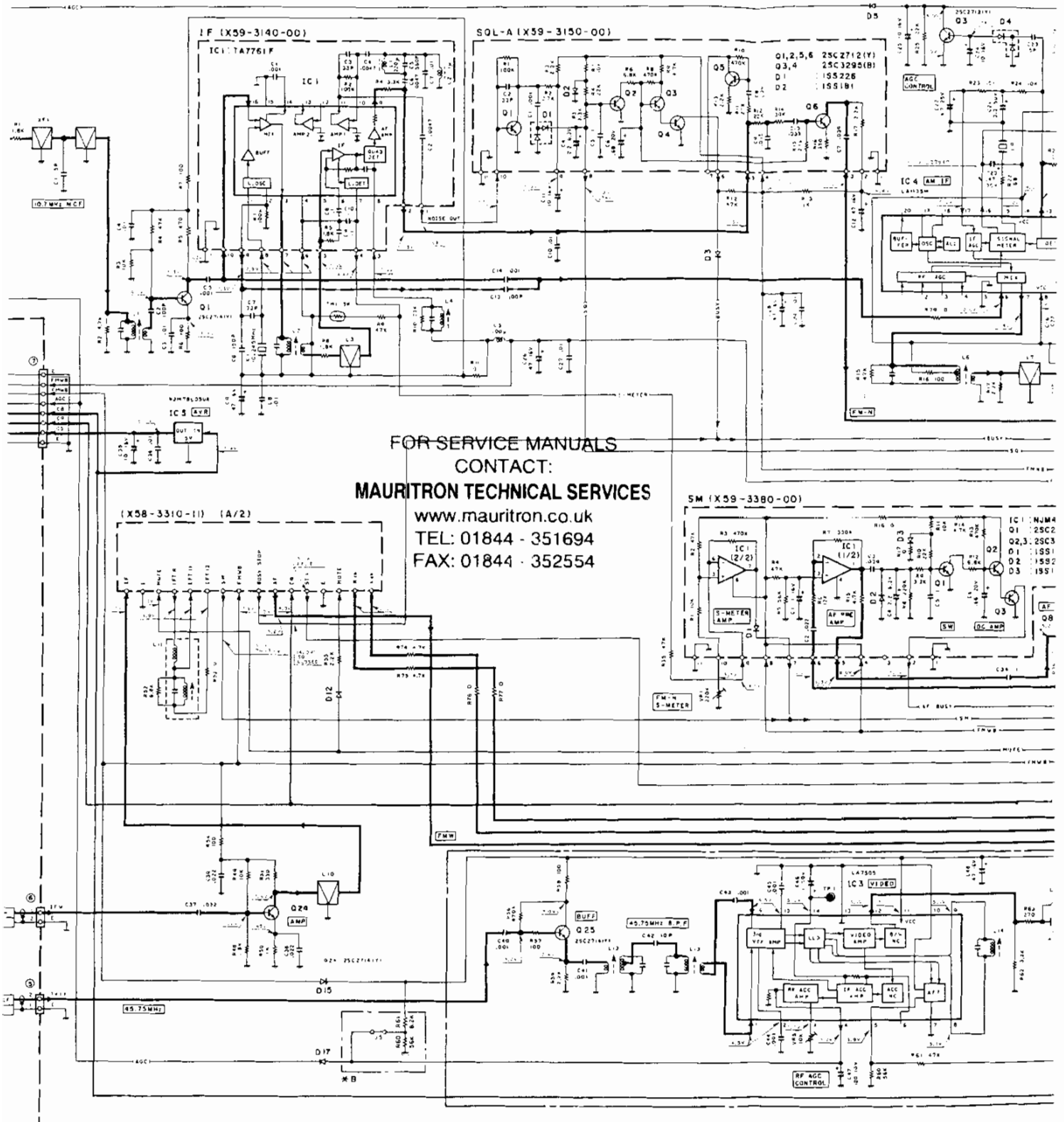

FOR SERVICE MANUALS
CONTACT:
MAURITRON TECHNICAL SERVICES
www.mauritron.co.uk
TEL: 01844 - 351694
FAX: 01844 - 352554

IC1 : MC7808C or UA7808
IC2 : μ PC1242H
IC3 : LA7505
IC4 : LA1135M
IC5 : WJM78L05UA

Q1, 24, 25 : 25C2714(Y)
Q3, 5, 6 : 25C2712(Y)
Q4 : 25A1162(Y)
Q8, 22 : 25K208(Y)
Q9 ~ 12 : 25B698

Q13-16, 23, 27 : 07C144EK
Q26 : 25C1959(Y)

D1, 3, 5 ~ 7, 12, 14 ~ 17 : RLS-73
D2 : 05M1A1
D4 : 155226

NO.	A	B
X48-3040-XX	J510	NOT USED
X48-3040-XX	NOT USED	USED

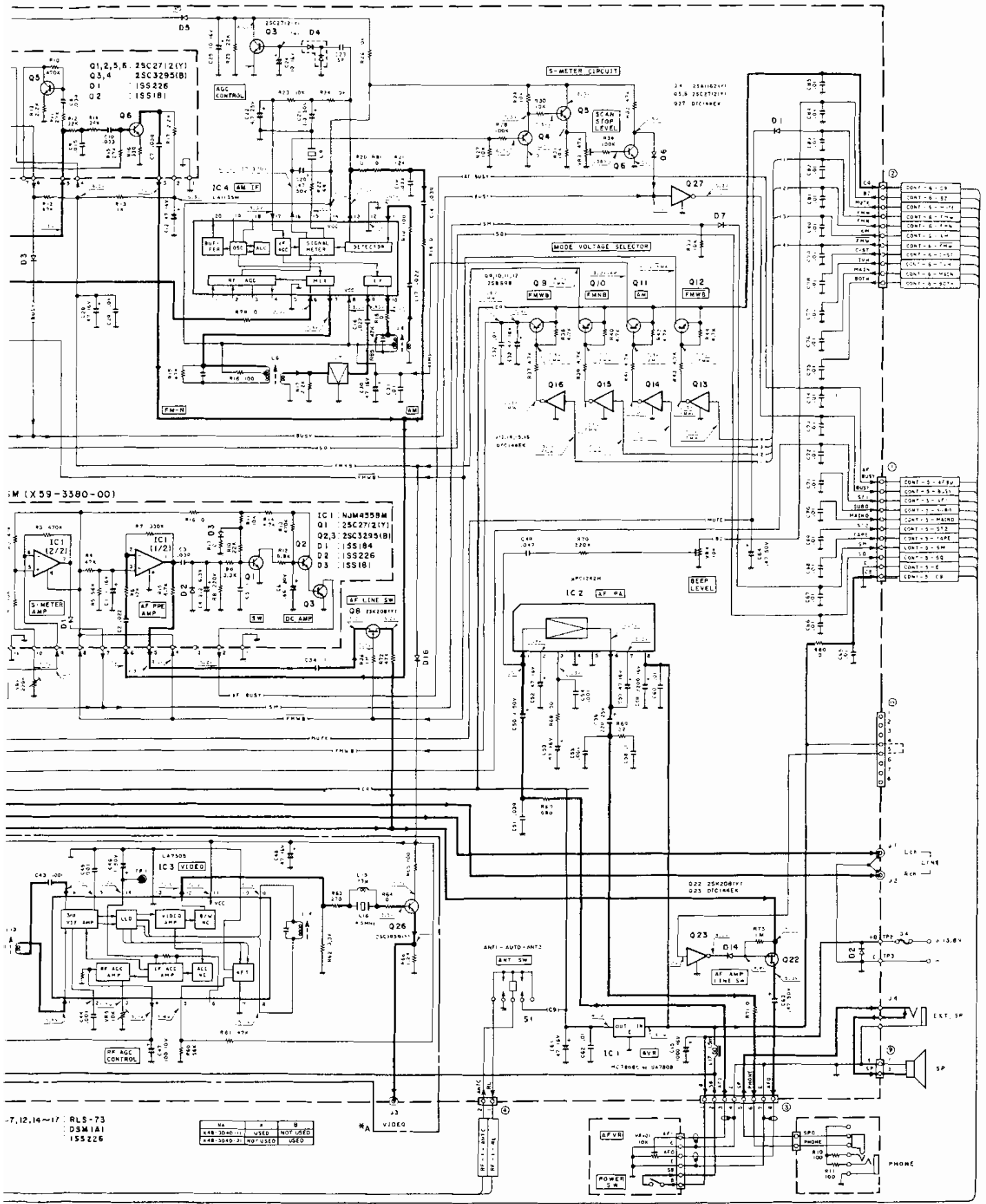

M (X59-3380-00)

-7,12,14~17 RLS-73
DSM1(A)
155226

NO.	A	B
K48-3040 (1)	USED	NOT USED
K48-3040 (2)	NOT USED	USED

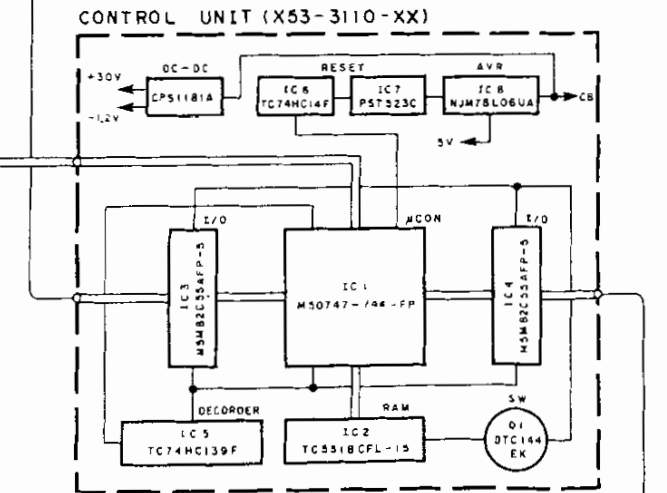
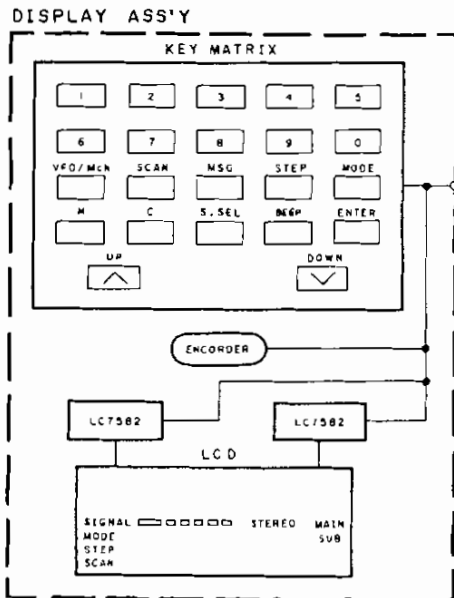
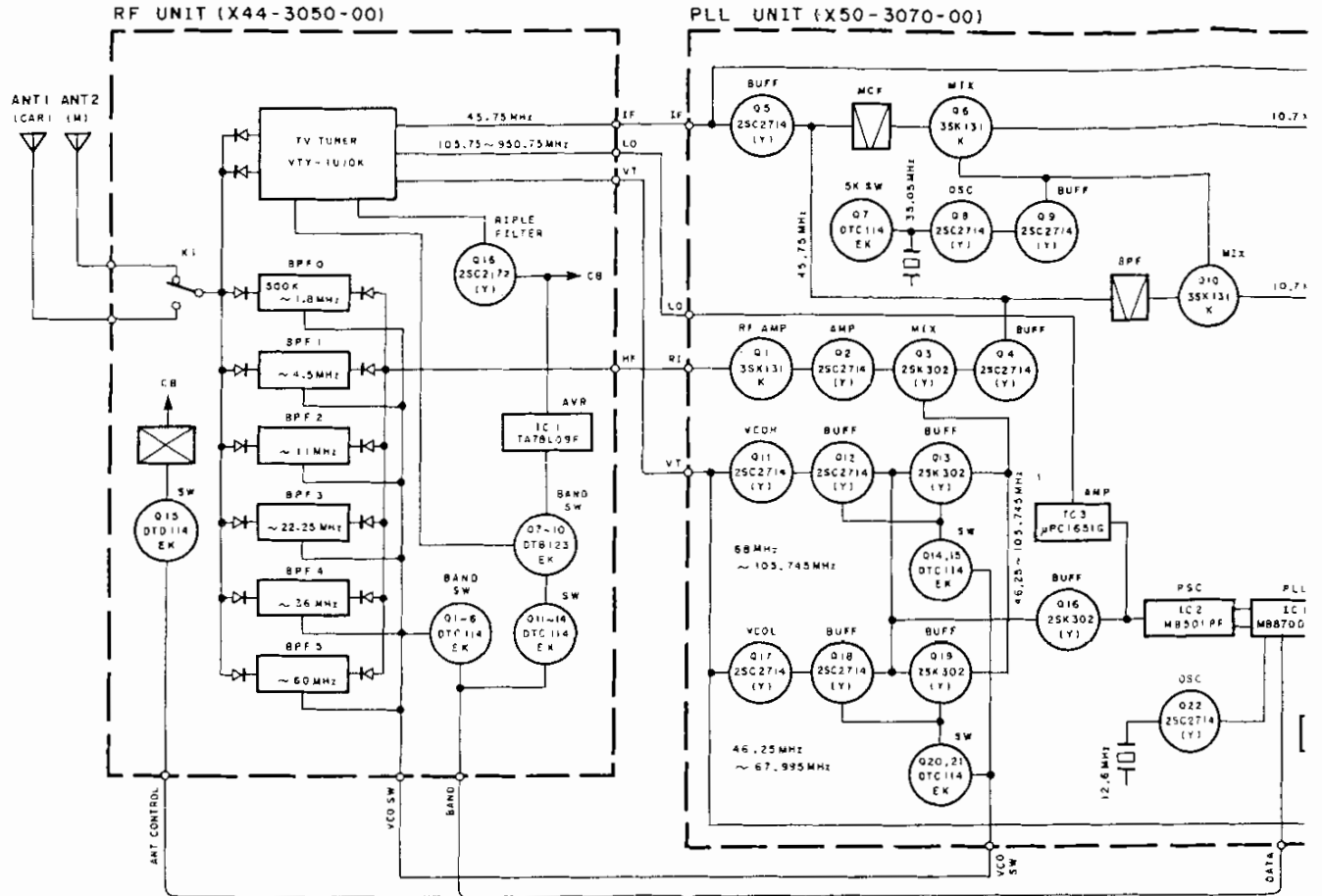

FOR SERVICE MANUALS
CONTACT:
MAURITRON TECHNICAL SERVICES

www.mauritron.co.uk
TEL: 01844 - 351694
FAX: 01844 - 352554

Z-1 RZ-1

BLOCK DIAGRAM

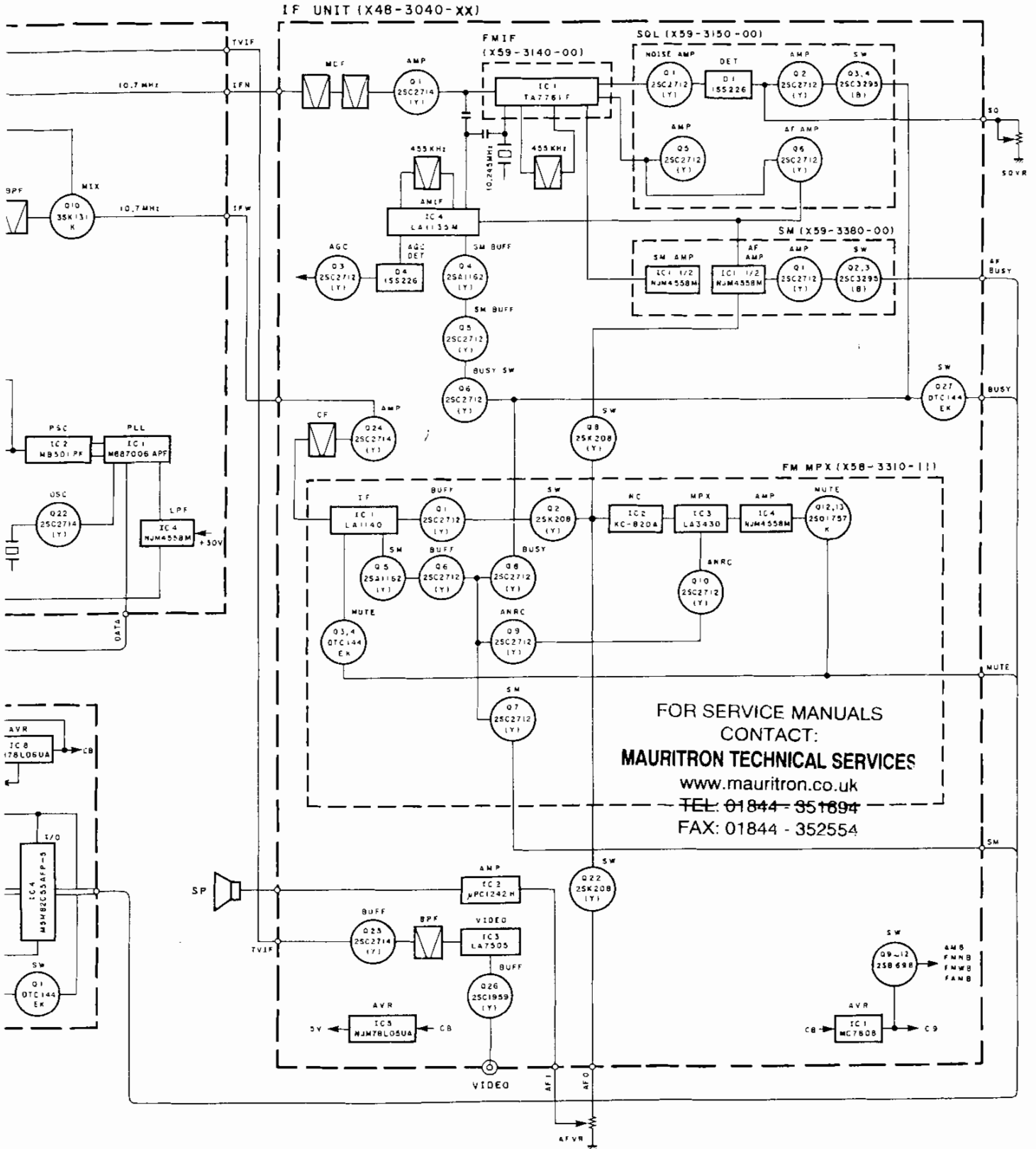

RZ-1(K)

LEVEL DIAGRAM

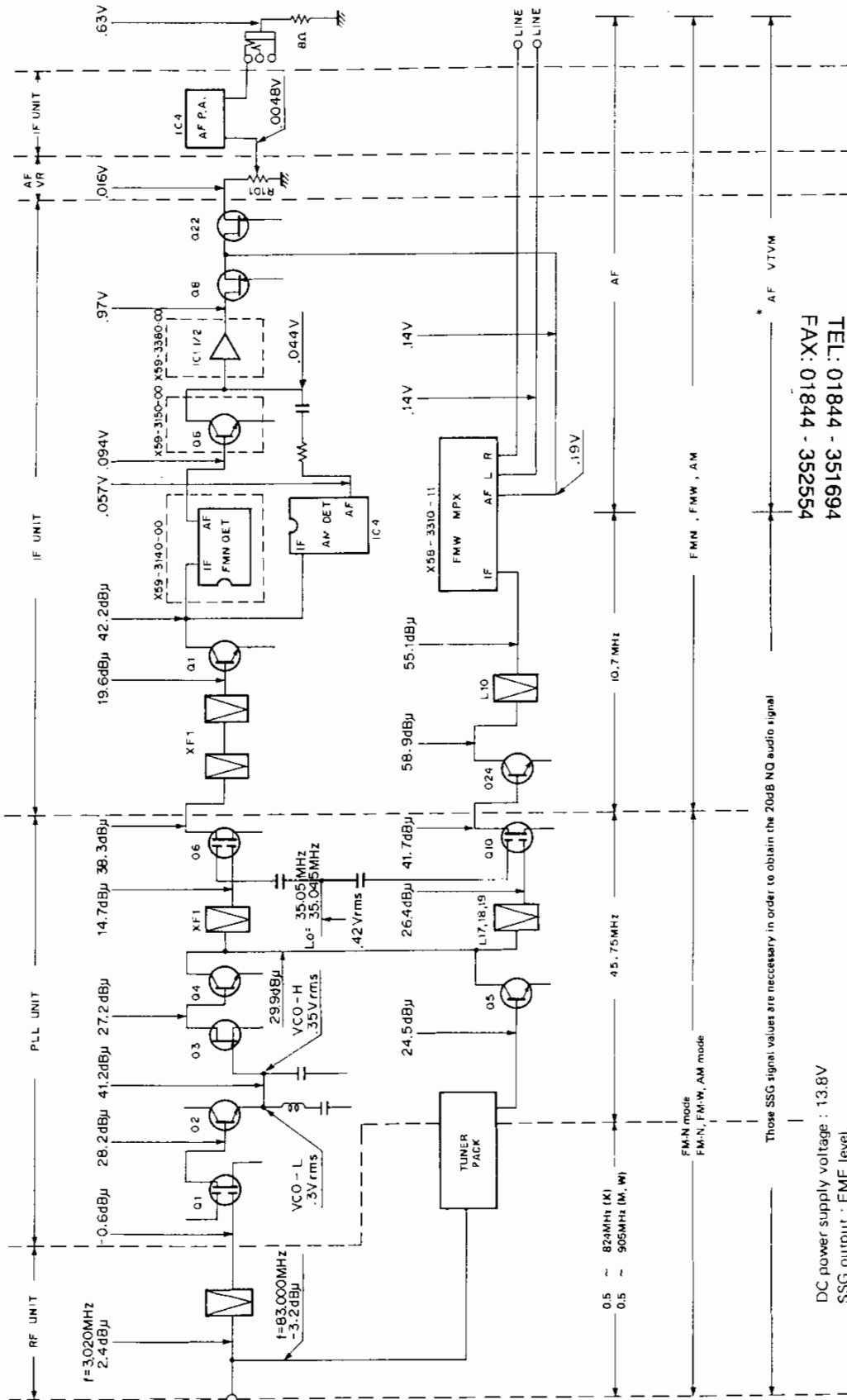

FOR SERVICE MANUALS
 CONTACT:
MAURITRON TECHNICAL SERVICES
 www.mauritron.co.uk
 TEL: 01844 - 351694
 FAX: 01844 - 352554

These SSG signal values are necessary in order to obtain the 20dB NO audio signal

DC power supply voltage : 13.8V
 SSG output : EMF level.

- After Q6 and Q10 : These signal level values were measured, using a standard modulated signal (FM MOD : 1kHz, FM DEV : 3kHz, AM MOD : 400Hz, AM DEV : 30%, SSG output : 60dBu) when 0.63V/8 Ω audio signals are obtained (using the AF GAIN VR) from 10.7MHz.
- SSG output was measured, using a 0.01 μ F capacitor.

TERMINAL FUNCTIONS

Connector No.	Terminal No.	Terminal Name	Terminal Function
RF UNIT (X44-3050-00)			
		ANT1 E	Antenna for car. GND.
		ANT2 E	Fixed antenna. GND.
CN1	1 2	ANTC RL	Antenna control output. Relay control input.
CN2		B9 B1 B3 B8 B6 E B5 B7 B4 B2 ANTC B10	Band data input 9. Band data input 1. Band data input 3. Band data input 8. Band data input 6. GND. Band data input 5. Band data input 7. Band data input 4. Band data input 2. Antenna control input. Band data input 10.
CN3	1 2 3 4 5 6 7 8 9 10	E VT AGC VCL VCH CB E HF E IF LO E	GND. VCO control voltage. AGC line. VCO select signal (~ 22.25MHz). VCO select signal (~ 60MHz). Common +B line. GND. Low band RF signal line (Less than 60MHz). GND. 1st IF output (45.75MHz). VCO output. GND.
IF UNIT (X48-3040-XX)			
CN1		AF BUSY BUSY ST1 SUBD MAIND ST2 TAPE SM SQ E CB	Audio BUSY output. BUSY output. Stereo display output (FM). Not used. Not used. Not used. Not used. S-meter output. Squelch output. GND. Common +B line.
CN2		C9 BZ MUTE FMW FMN AM FMW C-ST TVH MAIN BOTH	Common +8V line. Beep input. MUTE input. Mode selector (FM-W). Mode selector (FM-N). Mode selector (AM). Mode selector (except FM-W). Not used. Not used. Not used. Not used.

Connector No.	Terminal No.	Terminal Name	Terminal Function
CN3	1 2 3 4 5 6 7 8	B SB AFI E SP PHONE E AFO	+B line. Switched +B line. AF input. GND. SP input. PHONE output. GND. AF output.
CN4	1 2	RL ANTC	Relay control output. Antenna control input.
CN5	1 2	E TVIF	GND. TV IF input. K type only
CN6	1 2	IFW E	FM-W 2nd IF input. GND.
CN7		E FMWB FMWB AGC CB C9 C5 E	GND. FM-N +8V line. FM-W +8V line. AGC line. Common +B line. Common +8V line. Common +5V line. GND.
CN8	1 2	E IFN	GND. FN-N 2nd IF input.
CN9	1 2	E SP	GND. Speaker output.
CN10	1 2	ATT ON	Attenuator output. Attenuator "ON" input.
J1		LINE (L)	Stereo L channel output.
J2		LINE (R)	Stereo R channel output.
J3		VIDEO	Video output. K type only
J4		EXT. SP	External speaker output.
PLL UNIT (X50-3070-00)			
CN1	1 2 3 4 5 6 7 8 9 10	IF E HF E CB VCH VCL AGC VT E	1st IF input. GND. Low band RF input (Less than 60MHz). GND. Common +B line. VCO select input (~ 60MHz). VCO select input (~ 22.25MHz). AGC line. VCO control voltage. GND.
CN2		E FMWB FMWB AGC CB 9C 5C E	GND. FM-N +8V line. FM-W +8V line. AGC line input. Common +B line. Common +8V line. Common +5V line. GND.

TERMINAL FUNCTIONS

Connector No.	Terminal No.	Terminal Name	Terminal Function
CN3	1	IFN	FN-N 2nd IF output.
	2	E	GND.
CN4	1	E	GND.
	2	E	GND.
	3	IFW	FM-W 2nd IF output.
CN5		5K	5kHz shift data input.
		CLK	PLL clock input.
		EN	PLL enable input.
		DAT	PLL data input.
		-1.4V	-1.4V line.
		E	GND.
		PSC SW	Pre-scaler switch.
		30V	+30V line.
CN6	1	E	GND.
	2	TV IF	TV IF output. K type only.
		TP4	VCO input.
		TP5	GND.
CONTROL UNIT (X53-3110-XX)			
CN1	1	KS5	Key scan 5.
	2	KS4	Key scan 4.
	3	KS3	Key scan 3.
	4	KS2	Key scan 2.
	5	KS1	Key scan 1.
	6	KS0	Key scan 0.
	7	DOWN	Down key input.
	8	UP	Up key input.
	9	KR3	Key return 3.
	10	KR2	Key return 2.
	11	KR1	Key return 1.
	12	KR0	Key return 0.
	13	E	GND.
CN2	1	5C	Common +5V line.
	2	ENC1	Encoder pulse 1.
	3	ENC2	Encoder pulse 2.
	4	LAMP	Lamp GND.
	5	LAMP	Lamp common +9V line.
	6	SQ	Squelch vol.
	7	SM	S-meter output.
	8	DATA	LCD serial data output.
	9	CLK	LCD serial clock output.
	10	INH	LCD inhibit output.
	11	EN1	LCD driver enable 1.
	12	EN2	LCD driver enable 2.
CN3		RFS	RF switch output.
		30V	+30V line.
		PSC SW	Pre-scaler switch.
		E	GND.
		-1.4V	-1.4V line.
		DAT	PLL serial data output.
		EN	PLL enable output.
		CLK	PLL serial clock output.
		5K	5kHz shift data output.

Connector No.	Terminal No.	Terminal Name	Terminal Function
CN4		B9	Band data output 9.
		B1	Band data output 1.
		B3	Band data output 3.
		B8	Band data output 8.
		B6	Band data output 6.
		E	GND.
		B5	Band data output 5.
		B7	Band data output 7.
		B4	Band data output 4.
		B2	Band data output 2.
CN5		ANTC	Antenna control output.
		B10	Band data output 10.
		AF BUSY	Audio BUSY input.
		BUSY	BUSY input.
		ST1	Stereo display input (FM).
		SUBD	Not used.
		MAIND	Not used.
		ST2	Not used.
		TAPE	Not used.
		SM	S-meter input.
CN6		SQ	Squelch input.
		E	GND.
		CB	Common +B line.
		C9	Common +8V line.
		BZ	Beep output.
		MUTE	MUTE output.
		FMW	Mode output (FM-W).
		FMN	Mode output (FM-N).
		AM	Mode output (AM).
		FMW	Mode output (except FM-W).
	C-ST	Not used.	
	TVH	Not used.	
	MAIN	Not used.	
	BOTH	Not used.	
FM MPX (X58-3310-11)			
CN1		IF	IF input (10.7MHz).
		E	GND.
		MUTE	MUTE input.
		IFT9	IFT output.
		IFT11	IFT input.
		IFT13	IFT.
		SM	S-meter output.
CN2		FMWB	FM-W +8V line.
		L ch	Stereo L channel output.
		R ch	Stereo R channel output.
		MUTE	MUTE input.
		E	GND.
		ST1	Stereo display output (FM).
		C9	Common +8V line.
	AF	Audio output	
	BUSY STOP	BUSY output	

FOR SERVICE MANUALS

CONTACT:

MAURITRON TECHNICAL SERVICES

www.mauritron.co.uk

TEL: 01844 - 351694

FAX: 01844 - 352554