

ICOM

**SERVICE
MANUAL**

V/UHF MULTI BAND
ALL MODE TRANSCEIVER

IC-970

IC-970M

IC-970D

Icom Inc.

はじめに

本書は VHF/UHF 帯マルチバンド・オールモードトランシーバー IC-970/IC-970M/IC-970D のサービスマニュアルです。

改良による回路変更等で本文の内容に多少の相違点が生じますので、修理、調整にあたり、不明の箇所や疑問が発生した場合は、お手数ですが弊社営業所、サービスへお問い合わせください。

目次

1	定 格	1-1~2
2	分解図	2-1~7
2-1	シャーシ部	2-1
2-2	前面部	2-3
2-3	SW (A), SW (B) UNIT 部	2-4
2-4	後面部	2-5
2-5	TENKEY	2-7
2-6	付属品	2-7
3	PARTS LIST	3-1~32
4	調整方法	4-1~23
4-1	調整の準備	4-1
4-2	VHF PLL 調整	4-2
4-3	UHF PLL 調整	4-4
4-4	RF-A 調整	4-4
4-5	受信部調整	4-6
4-6	送信部調整	4-16
5	部品配置図	5-1~12
5-1	FRONT UNIT	5-1
5-2	LOGIC UNIT	5-3
5-3	MAIN UNIT (1)	5-4
5-4	MAIN UNIT (2)	5-5
5-5	144, 430 DDS UNIT	5-6
5-6	PLL-A UNIT	5-7
5-7	PLL-B UNIT	5-8
5-8	RF-A, RF-B UNIT	5-9
5-9	OSC, OSC (B), CTRL UNIT	5-10
5-10	JACK-A, JACK-B, DRIVER, CONNECT UNIT	5-10
5-11	144 PA UNIT	5-11
5-12	430 PA UNIT	5-12
6	回路図と電圧分布	6-1~7
7	ブロック図	7-1

■一般仕様

- 周波数範囲 : 144~146, 430~440 MHz, 1260~1300 MHz (UX-97 装着時)
- 電波型式 : SSB (USB/LSB), CW, FM
A5、A9 (TV-970+UX-97 装着時)
- アンテナインピーダンス : 50Ω 不平衡
- 使用温度範囲 : -10°C~+60°C
- 周波数安定度 : ±3ppm 以内 (0°C~+50°C)
- 周波数ステップ : SSB, CW 10Hz

FM 5, 10, 12.5, 20, 25, 100kHz
全モード共 1kHz ステップ/1MHz ステップ

- 電源電圧 : DC 13.8V±15% (DC 電源タイプ)
AC 100V±10% (AC 電源内蔵タイプ)

- 接地方式 : マイナス接地

- 消費電流 :

	IC-970	IC-970M	IC-970D
受信待ち受け時	2000 [3000] mA		
受信最大出力時	2500 [3500] mA		
送信 LOW	3.5 [4.5] A	4.5 [5.5] A	7.0 [8.0] A
送信 HIGH	6.0 [8.0] A	9.0 [11.0] A	16.0 [18.0] A

[] 内は UX-97/TV-970 装着時です。

- 外形寸法 : 425 (W) × 149 (H) × 406 (D) mm (突起物を含まず)

- 重量 :

DC 電源タイプ	IC-970	14.5kg
	IC-970D	15.0kg
AC 電源内蔵タイプ	IC-970/M	16.8kg
	IC-970D	17.3kg

■送信部

- 送信出力 :

MODE	周波数帯域	IC-970	IC-970M	IC-970D
FM	144MHz 帯	1.5~10W	12.5~25W	6~45W
	430MHz 帯			6~40W
	1200MHz 帯	1~10W		
SSB/CW	144MHz 帯	1.5~10W	2.5~25W	5~35W
	430MHz 帯			5~30W
	1200MHz 帯	1~10W		

- 変調方式 : SSB 平衡変調
FM リアクタンス変調
A5 低電力変調
A9 低電力変調およびリアクタンス変調

- 最大周波数偏移 : ±5kHz
- スプリアス発射強度 : -60dB 以下
- マイクロホンインピーダンス : 600Ω
- 搬送波抑圧比 : 40dB 以上
- 不要側波帯抑圧比 : 40dB 以下
- SSB 発生方式 : フィルター方式

■受信部

- 受信方式 : 144MHz帯 (SSB, CW) シングルスーパーヘテロダイン方式
144MHz帯 (FM) ダブルスーパーヘテロダイン方式
430/1200MHz帯 (SSB, CW) ダブルスーパーヘテロダイン方式
430/1200MHz帯 (FM) トリプルスーパーヘテロダイン方式
- 中間周波数 : MAIN バンド

	第 1	第 2	第 3
• 144MHz帯			
FM	10.85MHz	445kHz	—
SSB	10.85MHz	—	—
CW	10.8491MHz	—	—
• 430MHz帯			
FM	71.25MHz	10.85MHz	455kHz
SSB	71.25MHz	10.85MHz	—
CW	71.2491MHz	10.8491MHz	—
• 1200MHz帯			
FM	131.65MHz	10.85MHz	455kHz
SSB	131.65MHz	10.85MHz	—
CW	131.6491MHz	10.8491MHz	—

SUB バンド

	第 1	第 2	第 3
• 144MHz帯			
FM	10.95MHz	445kHz	—
SSB	10.95MHz	—	—
CW	10.9491MHz	—	—
• 430MHz帯			
FM	71.35MHz	10.95MHz	455kHz
SSB	71.35MHz	10.95MHz	—
CW	71.3491MHz	10.9491MHz	—
• 1200MHz帯			
FM	131.75MHz	10.95MHz	455kHz
SSB	131.75MHz	10.95MHz	—
CW	131.7491MHz	10.9491MHz	—

- 受信感度 : SSB/CW (144/430/1200MHz帯) 10dB S/N -19dB μ (0.11 μ V) 以下
FM (144/430/1200MHz帯) 12dB SINAD -15dB μ (0.18 μ V) 以下

選択度	SSB/CW	FM
-6dB	2.3kHz 以上	15.0kHz 以上
-60dB	4.2kHz 以下	30.0kHz 以下

- スケルチ感度 : SSB, CW -5dB μ (0.56 μ V) 以下
FM -15dB μ (0.18 μ V) 以下
- スプリアス妨害比 : 60dB 以上 (1200MHz帯 50dB 以上)
- 低周波出力 : 1.5W 以上 (8 Ω 10% 歪時)
- 低周波負荷インピーダンス : 8 Ω
- RIT 可変範囲 : \pm 9.99kHz
- NOTCH 可変範囲 : \pm 1.2kHz 以上
- NOTCH 減衰度 : 25dB 以上

(注) 1200MHz帯を運用するには、UX-97 のオプションユニットが必要です。

(注) 1200MHz帯の ATV を運用するには、UX-97、TV-970 のオプションユニットが必要です。

※測定法は JARL で定めた測定法によります。

※定格は改良のため予告なく変更することがあります。

2-1 シャーシ部

図面 番号	品 番	部 品 名	数量	図面 番号	品 番	部 品 名	数量
①	8510000100	ヘリカルケース NO.5	5	③⑤	8510001560	DET ケースフタ	1
②	8510000110	ヘリカルケース NO.6	1	③⑥	8810001820	モーターネジ M2.6×2.5	4
③	8930014140	アースバネ (D)	3	③⑦	8810001270	ナベネジ B1 M2.6×5	4
④	8510000070	ヘリカルケース NO.2	2	③⑧	8010009450	646 フロントシャーシ	1
⑤	8510000160	ヘリカルケース NO.11	1	③⑨	8930019270	スポンジ (CJ)	1
⑥	8510000070	ヘリカルケース NO.2	1	④⑩	2220000420	スイッチ ESD11H120[Dial click],etc.	3
⑦	8510002690	PA シールドケース (B)	1	④⑪	8510002922	PLL ケース-4	2
⑧	8510004360	PA シールドケース (B) フタ (A)	1	④⑫	8510005540	PLL ケース上フタ	1
⑨	8510002390	ミキサーシールドケース	1	④⑬	8510005550	PLL ケース下フタ	1
⑩	8810003160	クミネジ A M3×6	55	④⑭	8010009430	646 シャーシ側板 (左)	1
⑪	8810003360	クミネジ C M3×6	7	④⑮	8810002160	サラネジ M3×5	8
⑫	5210000220	ヒューズ FGMB 125V 3A	1	④⑯	6910002560	ワイヤー止め S-10-516L	7
⑬	6510006070	ヒューズホルダー F-429	2	④⑰	8930008120	アース金具 (A)	5
⑭	8410001420	646 CTRL ヒートシンク	1	④⑱	8510006530	PLL ケース上フタ (B)	1
⑮	8810003170	クミネジ A M3×8	5	④⑲	8510006540	PLL ケース下フタ (A)	1
⑯	8930006070	半ネジスペーサー-B	4	⑤⑩	8010009440	646 シャーシ側板 (右)	1
⑰	8810003750	アイコムネジ C9	4	⑤⑪	8010009490	646 PSシャーシ	1
⑱	8510002200	VCO ケース	1	⑤⑫	8010009580	646 ファンアングル (IC-970D)	1
⑲	8510000230	220 シールドケース	2	⑤⑬	8110003700	646 カバー (上)	1
⑳	8510000881	194 VCO ケース-1	1	⑤⑭	8930010091	77 SPスペーサー -1	1
㉑	8510001060	シールドケース	2	⑤⑮	2510000410	スピーカー T080S0110810	1
㉒	8410001430	646 MAIN ヒートシンク	1	⑤⑯	8930010040	77 SP金具	1
㉓	8810000240	ナベネジ M3×8	4	⑤⑰	8810005510	マルサラネジ M3×6 黒 BS	4
㉔	8830000100	ナット M3	4	⑤⑱	8810004690	バインドネジ M4×5 黒 BS	16
㉕	8510004430	194 シールドケース (B)	1	⑤⑲	8110003710	646 カバー (下)	1
㉖	8510001080	シールドケース (A)	2	⑥⑩	8810000390	ナベネジ M4×12	2
㉗	8510001101	シールドケース (A) フタ (A) -1	2	⑥⑪	8930011680	ゴム足 (G)	2
㉘	8930004070	アースバネ (C)	2	⑥⑫	8930011700	メインスタンドゴム	2
㉙	6910000690	アースプレート 59TC4772	1	⑥⑬	8810000360	ナベネジ M4×6	2
㉚	8930000140	スタット (J)	1	⑥⑭	8930011640	メインスタンド	2
㉛	8850000420	スプリングワッシャー M3 NI	1	⑥⑮	8930011630	サブスタンド	2
㉜	8010009481	646 シャーシ中板-1	1	⑥⑯	8930011690	サブスタンドゴム	2
㉝	8110003650	SWR ケースフタ (C)	1	⑥⑰	8930011770	スタンドバネ	2
㉞	8510001430	SWR ケース	1				

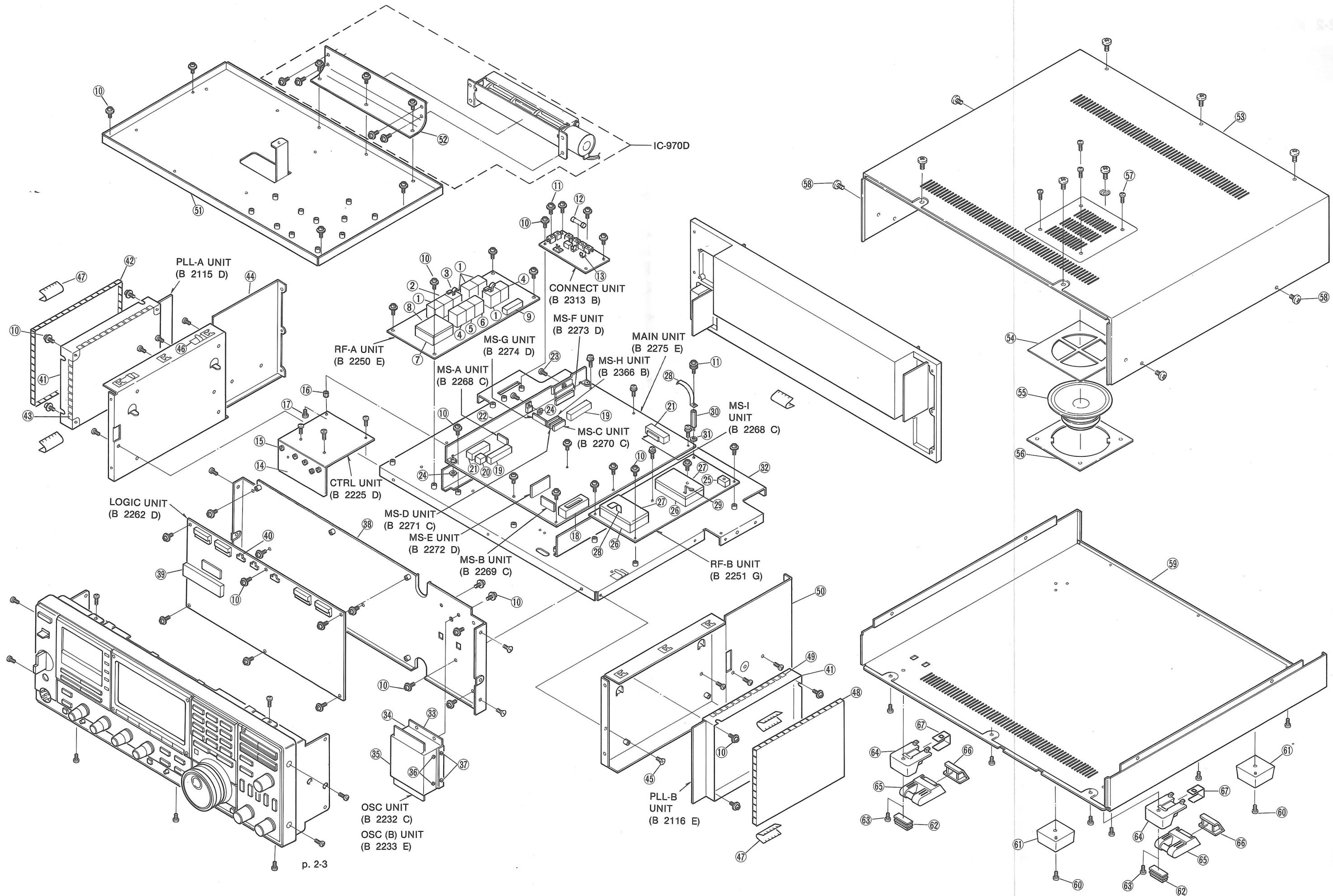

2-2 前面部

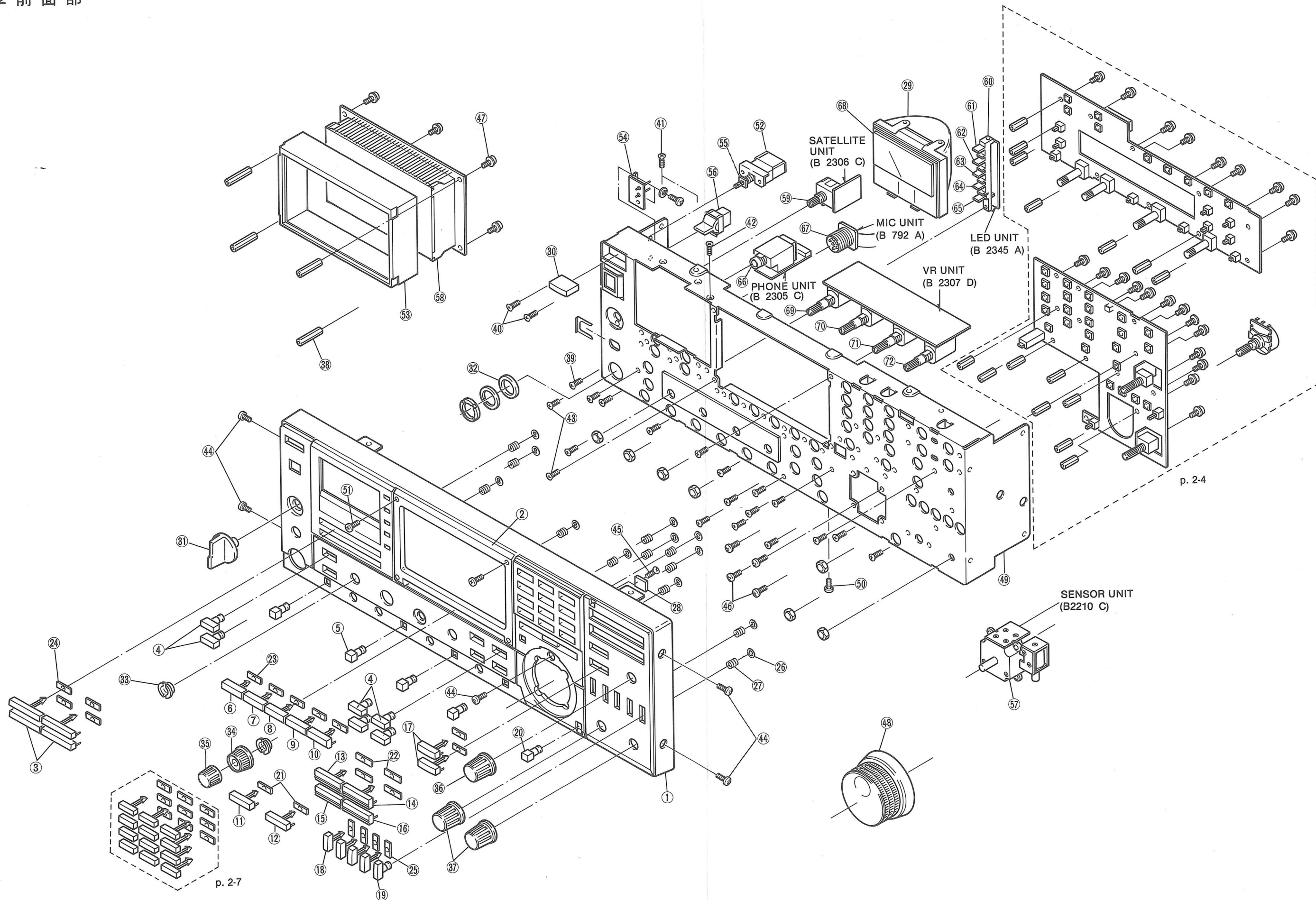

2-4 後面部

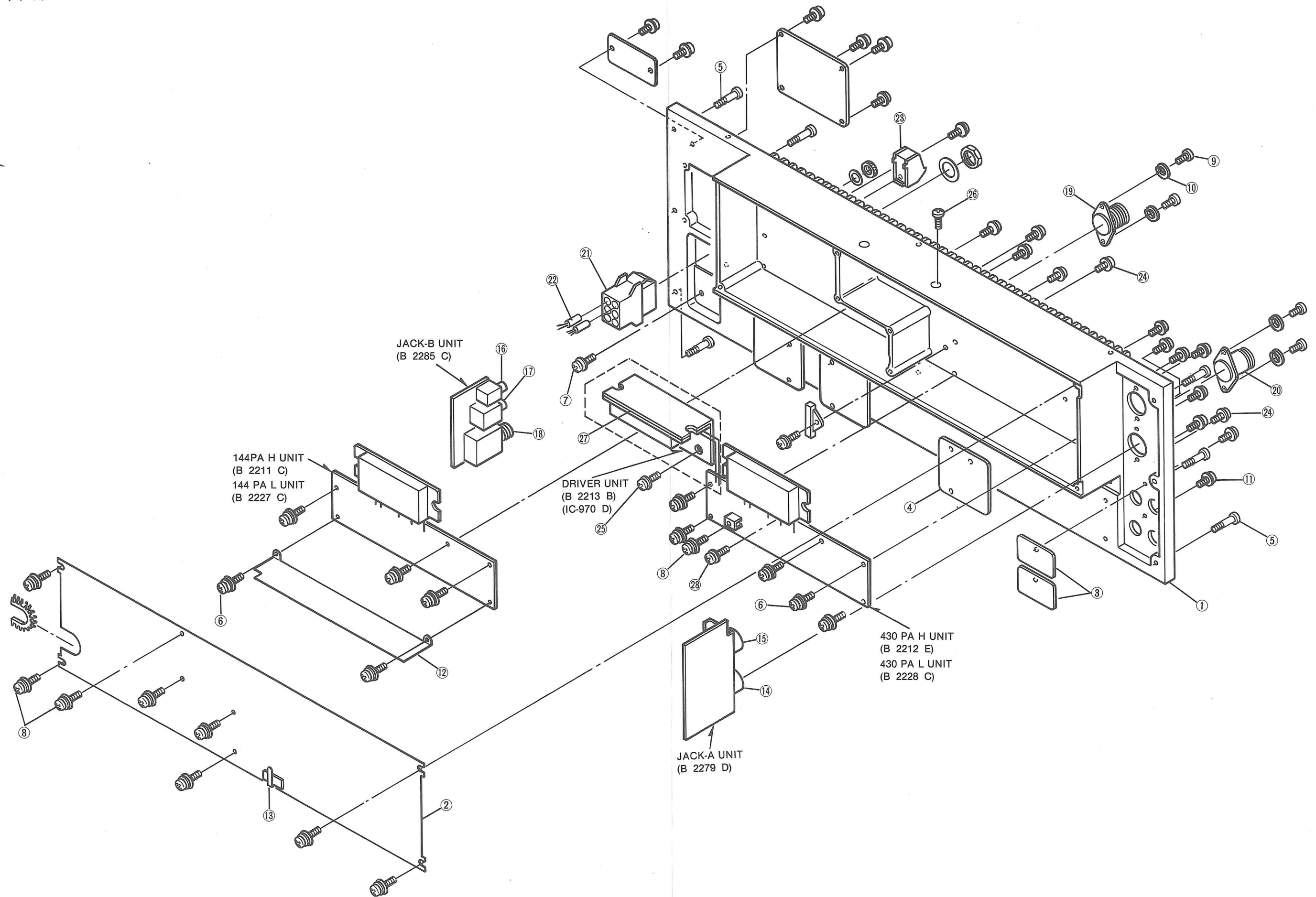

図面番号	品番	部品名	数量
①	8410001440	646 ヒートシンク	1
②	8010009460	PA カバー	1
③	8930017300	TVJ ブラインドプレート	2
④	8930017290	ANT ブラインドプレート	3
⑤	8810006030	ナベネジ M4×12 NI	6
⑥	8810003160	クミネジ A M3×6	11
⑦	8810003170	クミネジ A M3×8	1
⑧	8810003360	クミネジ C M3×6	9
⑨	8810001910	ナベネジ M3×6 NI BS	4
⑩	8850000420	スプリングワッシャー M3 NI	4
⑪	8810003250	クミネジ A M3×8 NI	12
⑫	8510006290	646 PA シールド板	1
⑬	6910002560	ワイヤー止め S-10-516L	1
⑭	6450000940	コネクター TCS5380-01-4151 [ACC ソケット]	1
⑮	6450000510	コネクター TCS5037-01-401 [DATA ソケット]	1
⑯	6450000100	コネクター HSJ0857-01-220 [REMOTE ジャック]	1
⑰	6450000930	コネクター HSJ0913-01-050 [EXT SP ジャック]	1
⑱	6450000460	コネクター HLJ4306-01-3080 [KEY ジャック]	1
⑲	6510000370	アンテナ コネクター MR-DS [ANT 144 MHz]	1
⑳	6510000330	アンテナ コネクター NR-DS [ANT 430 MHz]	1
㉑	6510003780	コネクター LLR-06 [DC 13.8V]	1
㉒	6510007650	ピン LLM 61T-2.0	6
㉓	6510000030	コネクター S-Q2054 [GND]	1
㉔	8810001900	ナベネジ M3×5 NI BS	3
㉕	8810003360	クミネジ C M3×6	2
㉖	8810003250	クミネジ A M3×8 NI	2
㉗	8930006470	モジュール押え板 (IC-970D)	1
㉘	8810003860	クミネジ A M4×8 (IC-970D)	4
	8810003170	クミネジ A M3×8 (IC-970/M)	4

2-5 TENKEY

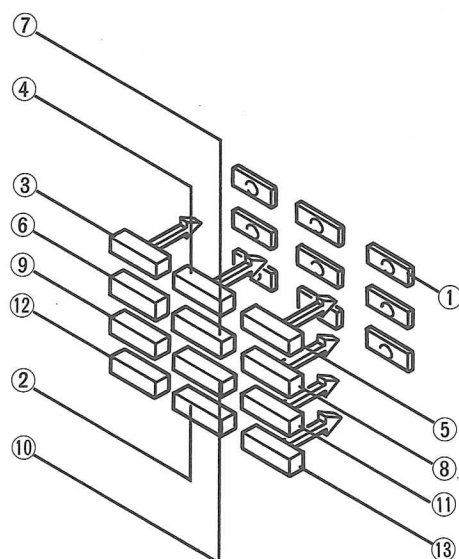

図面番号	品番	部品名	数量
①	8930018770	646 キーボードスポンジ (A)	12
②	8610006150	ボタン K143 [0]	1
③	8610006240	ボタン K143 (A) [1]	1
④	8610006250	ボタン K143 (B) [2]	1
⑤	8610006260	ボタン K143 (C) [3]	1
⑥	8610006270	ボタン K143 (D) [4]	1
⑦	8610006280	ボタン K143 (E) [5]	1
⑧	8610006290	ボタン K143 (F) [6]	1
⑨	8610006300	ボタン K143 (G) [7]	1
⑩	8610006310	ボタン K143 (H) [8]	1
⑪	8610006320	ボタン K143 (I) [9]	1
⑫	8610006330	ボタン K143 (J) [*]	1
⑬	8610006340	ボタン K143 (K) [ENT]	1

2-6 付属品

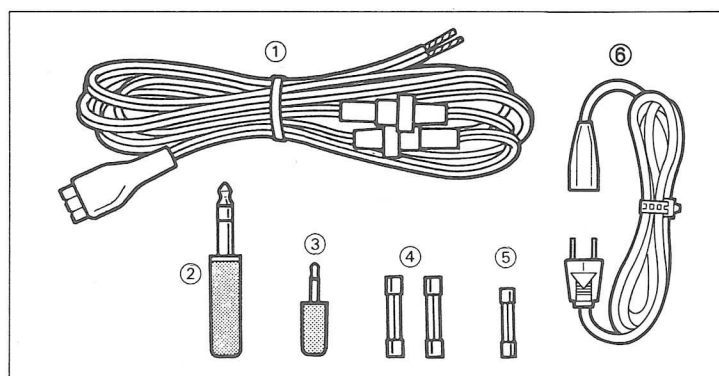

図面番号	品番	部品名	数量
①	OPC-025 A	DC 電源コード (DC電源タイプ)	1
②	5610000050	キープラグ AP330	1
③	5610000020	AP313 3.5φ CSプラグ	1
④	5210000080	ヒューズ FGB 20A (DC電源タイプ)	2
⑤	5210000180	ヒューズ FGMB 125V 5A (AC電源内蔵タイプ)	1
⑥	OPC-041	AC 電源コード (AC電源内蔵タイプ)	1

[PLL-A UNIT]

REF. NO.	ORDER NO.	DESCRIPTION	
IC1	1120001680	IC	M5223P
IC2	1130002960	IC	TC9181P
IC3	1110002050	IC	MB503P-G
IC4	1120000100	IC	M74LS90P
IC5	1110002030	IC	TA7808S
IC6	1180000010	IC	TA78L005AP
IC7	1790000050	IC	ND487C1-3R
IC8	1130000140	IC	TC4071BP
Q1	1560000130	FET	2SK125
Q4	1590000360	Transistor	RN2202
Q5	1590000340	Transistor	RN1202
Q8	1530000150	Transistor	2SC2668-O
Q9	1530002210	Transistor	2SC3776-D
Q10	1530000940	Transistor	2SC1571G
Q11	1530000150	Transistor	2SC2668-O
Q12	1530000940	Transistor	2SC1571G
Q13	1530000150	Transistor	2SC2668-O
Q14	1530000940	Transistor	2SC1571G
Q15	1530000150	Transistor	2SC2668-O
Q17	1590000340	Transistor	RN1202
Q18	1530000150	Transistor	2SC2668-O
Q19	1530000150	Transistor	2SC2668-O
Q20	1580000110	FET	3SK74 M
Q21	1530000150	Transistor	2SC2668-O
Q22	1530000591	Transistor	2SC2785 EL
Q23	1510000070	Transistor	2SA1048-Y
Q24	1530000591	Transistor	2SC2785 EL
Q25	1560000090	FET	2SK192A-GR
Q27	1530000150	Transistor	2SC2668-O
D1	1710000160	Diode	1SS133
D2	1720000060	Varicap	1SV50(1)E
D4	1710000160	Diode	1SS133
D6	1710000160	Diode	1SS133
D7	1710000050	Diode	1SS53
D9	1720000060	Varicap	1SV50(1)E
D10	1720000060	Varicap	1SV50(1)E
D11	1720000060	Varicap	1SV50(1)E
D12	1710000160	Diode	1SS133
L1	6140000580	Coil	LR-79
L2	6180000880	Coil	LAL 03NA 100K
L3	6180002590	Coil	LAL 02KR 120K
L4	6180000880	Coil	LAL 03NA 100K
L5	6180001410	Coil	LAL 02KR 100K
L6	6150001310	Coil	LS-145
L7	6110001770	Coil	LA-266
L8	6110001710	Coil	LA-257
L9	6110001720	Coil	LA-258
L10	6110001630	Coil	LA-246
L11	6180000840	Coil	LAL 03NA 3R9K
L12	6180000840	Coil	LAL 03NA 3R9K
L13	6180001410	Coil	LAL 02KR 100K
L14	6180000690	Coil	LAL 03NA R22M
L15	6110001780	Coil	LA-267
L16	6110001770	Coil	LA-266
L17	6180001390	Coil	LAL 02KR 2R2K
L18	6180002550	Coil	LAL 02KR R68K
L19	6110001640	Coil	LA-247
L20	6180001300	Coil	LAL 02NA 100K
L21	6180001410	Coil	LAL 02KR 100K
L22	6180000900	Coil	LAL 03NA 101K
L23	6180000880	Coil	LAL 03NA 100K
L24	6150000970	Coil	LS-112
L25	6150000970	Coil	LS-112
L26	6180000900	Coil	LAL 03NA 101K
L27	6180000900	Coil	LAL 03NA 101K
L28	6140000580	Coil	LR-79

[PLL-A UNIT]

REF. NO.	ORDER NO.	DESCRIPTION	
L29	6130000990	Coil	LB-135
L30	6110001720	Coil	LA-258
L31	6150000970	Coil	LS-112
L32	6180001410	Coil	LAL 02KR 100K
L33	6180000900	Coil	LAL 03NA 101K
L34	6180000880	Coil	LAL 03NA 100K
L35	6180000880	Coil	LAL 03NA 100K
L36	6180001300	Coil	LAL 02NA 100K
L37	6180000880	Coil	LAL 03NA 100K
L38	6180001410	Coil	LAL 02KR 100K
L39	6180002430	Coil	LAL 04NA 470K
L40	6180000880	Coil	LAL 03NA 100K
L41	6180001410	Coil	LAL 02KR 100K
L42	6180000880	Coil	LAL 03NA 100K
L43	6180001410	Coil	LAL 02KR 100K
L44	6180001410	Coil	LAL 02KR 100K
L45	6180000880	Coil	LAL 03NA 100K
L46	6180001410	Coil	LAL 02KR 100K
L47	6180000880	Coil	LAL 03NA 100K
L51	6130001860	Coil	LB-203
L52	6180001380	Coil	LAL 02KR 1R0K
L54	6110001650	Coil	LA-248
L55	6110002110	Coil	LA-382
L56	6110002110	Coil	LA-382
L57	6110001530	Coil	LA-233
L58	6110001620	Coil	LA-245
L59	6110001690	Coil	LA-255
L66	6180000900	Coil	LAL 03NA 101K
L67	6180001380	Coil	LAL 02KR 1R0K
L68	6180000690	Coil	LAL 03NA R22M
L69	6180000770	Coil	LAL 03NA 1R0M
L70	6140000930	Coil	LR-116
L71	6140000930	Coil	LR-116
L72	6180001300	Coil	LAL 02NA 100K
L73	6180001410	Coil	LAL 02KR 100K
L74	6180000880	Coil	LAL 03NA 100K
L75	6180000900	Coil	LAL 03NA 101K
L76	6180002420	Coil	LAL 02KR R39K
R1	7010003240	Resistor	ELR20J 47 Ω
R2	7010003320	Resistor	ELR20J 220 Ω
R3	7010004070	Resistor	R20J 100 Ω
R4	7010004310	Resistor	R20J 8.2 k Ω
R5	7010003580	Resistor	ELR20J 22 k Ω
R11	7010003490	Resistor	ELR20J 5.6 k Ω
R12	7010004070	Resistor	R20J 100 Ω
R14	7010003480	Resistor	ELR20J 4.7 k Ω
R15	7010004030	Resistor	R20J 47 Ω
R16	7010003810	Resistor	ELR20J 2.2 M Ω
R18	7010004190	Resistor	R20J 1 k Ω
R23	7010003410	Resistor	ELR20J 1.2 k Ω
R24	7010003280	Resistor	ELR20J 100 Ω
R27	7010003400	Resistor	ELR20J 1 k Ω
R28	7010003530	Resistor	ELR20J 10 k Ω
R29	7010003240	Resistor	ELR20J 47 Ω
R30	7010003620	Resistor	ELR20J 47 k Ω
R31	7010003280	Resistor	ELR20J 100 Ω
R32	7010003400	Resistor	ELR20J 1 k Ω
R33	7010001280	Resistor	R25XJ 10 k Ω
R34	7010003700	Resistor	ELR20J 220 k Ω
R35	7010003440	Resistor	ELR20J 2.2 k Ω
R36	7010003280	Resistor	ELR20J 100 Ω
R37	7010004070	Resistor	R20J 100 Ω
R39	7010003280	Resistor	ELR20J 100 Ω
R41	7010003320	Resistor	ELR20J 220 Ω
R42	7010003820	Resistor	ELR20J 3.3 M Ω
R43	7010003510	Resistor	ELR20J 6.8 k Ω
R44	7010003610	Resistor	ELR20J 39 k Ω
R45	7010004070	Resistor	R20J 100 Ω
R46	7010001150	Resistor	R25XJ 1 k Ω
R47	7010003810	Resistor	ELR20J 2.2 M Ω

[PLL-A UNIT]

REF. NO.	ORDER NO.	DESCRIPTION
R48	7010004180	Resistor R20J 820 Ω
R49	7010003920	Resistor R20J 5.6 Ω
R50	7010003280	Resistor ELR20J 100 Ω
R51	7010003360	Resistor ELR20J 470 Ω
R52	7010003490	Resistor ELR20J 5.6 kΩ
R53	7010003320	Resistor ELR20J 220 Ω
R54	7010003390	Resistor ELR20J 820 Ω
R55	7010004180	Resistor R20J 820 Ω
R56	7010003920	Resistor R20J 5.6 Ω
R57	7010003400	Resistor ELR20J 1 kΩ
R58	7010004410	Resistor R20J 47 kΩ
R59	7010004180	Resistor R20J 820 Ω
R60	7010003400	Resistor ELR20J 1 kΩ
R61	7010001280	Resistor R25XJ 10 kΩ
R62	7010004230	Resistor R20J 2.2 kΩ
R63	7010004320	Resistor R20J 10 kΩ
R64	7010003620	Resistor ELR20J 47 kΩ
R71	7010004270	Resistor R20J 4.7 kΩ
R72	7010003400	Resistor ELR20J 1 kΩ
R73	7010003580	Resistor ELR20J 22 kΩ
R74	7010004110	Resistor R20J 220 Ω
R76	7010004190	Resistor R20J 1 kΩ
R78	7010004190	Resistor R20J 1 kΩ
R79	7010004120	Resistor R20J 270 Ω
R80	7010004130	Resistor R20J 330 Ω
R81	7010004070	Resistor R20J 100 Ω
R82	7010003400	Resistor ELR20J 1 kΩ
R83	7010003580	Resistor ELR20J 22 kΩ
R84	7010003360	Resistor ELR20J 470 Ω
R85	7010003490	Resistor ELR20J 5.6 kΩ
R86	7010003320	Resistor ELR20J 220 Ω
R91	7010001230	Resistor R25XJ 4.7 kΩ
R93	7010003660	Resistor ELR20J 100 kΩ
R94	7010003660	Resistor ELR20J 100 kΩ
R95	7010003380	Resistor ELR20J 680 Ω
R96	7010003280	Resistor ELR20J 100 Ω
R102	7010003410	Resistor ELR20J 1.2 kΩ
R103	7010004280	Resistor R20J 5.6 kΩ
R104	7010003280	Resistor ELR20J 100 Ω
R105	7010004070	Resistor R20J 100 Ω
R106	7010004120	Resistor R20J 270 Ω
R107	7010003980	Resistor R20J 18 Ω
R108	7010003330	Resistor ELR20J 270 Ω
R110	7010003240	Resistor ELR20J 47 Ω
R117	7010003580	Resistor ELR20J 22 kΩ
R118	7010004280	Resistor R20J 5.6 kΩ
R122	7010003440	Resistor ELR20J 2.2 kΩ
R124	7010003910	Resistor R20J 4.7 Ω
R126	7010004120	Resistor R20J 270 Ω
R127	7010003980	Resistor R20J 18 Ω
R128	7010004120	Resistor R20J 270 Ω
R130	7010004120	Resistor R20J 270 Ω
R131	7010003980	Resistor R20J 18 Ω
R132	7010004120	Resistor R20J 270 Ω
R133	7010003550	Resistor ELR20J 15 kΩ
R137	7510000320	Thermistor ERT-D2ZGL202S
R138	7510000320	Thermistor ERT-D2ZGL202S
C1	4040000150	Barrier Layer UAT 05X 472K
C2	4010000220	Ceramic DD104 SL 330J 50V
C3	4010000860	Ceramic DD106 CH 470J 50V
C4	4010000380	Ceramic DD107 SL 221J 50V
C5	4010000380	Ceramic DD107 SL 221J 50V
C6	4010000150	Ceramic DD104 SL 150J 50V
C7	4010000260	Ceramic DD104 SL 470J 50V
C8	4010000120	Ceramic DD104 SL 100D 50V
C9	4010000520	Ceramic DD108 B 472K 50V
C10	4010000080	Ceramic DD104 SL 080D 50V
C11	4010000080	Ceramic DD104 SL 080D 50V
C12	4040000150	Barrier Layer UAT 05X 472K
C13	4010000520	Ceramic DD108 B 472K 50V
C14	4040000260	Barrier Layer UZE 08X 104M
C15	4510004020	Electrolytic 50 MV 3R3 HW
C16	4010000560	Ceramic DD106 F 103Z 50V
C17	4510004010	Electrolytic 10 MV 470 HW
C21	4010000380	Ceramic DD107 SL 221J 50V
C23	4040000260	Barrier Layer UZE 08X 104M

[PLL-A UNIT]

REF. NO.	ORDER NO.	DESCRIPTION
C25	4010000520	Ceramic DD108 B 472K 50V
C26	4010000520	Ceramic DD108 B 472K 50V
C27	4010000040	Ceramic DD104 SL 020C 50V
C28	4010000120	Ceramic DD104 SL 100D 50V
C29	4010000300	Ceramic DD104 SL 680J 50V
C30	4010000260	Ceramic DD104 SL 470J 50V
C31	4010000280	Ceramic DD104 SL 560J 50V
C32	4010000200	Ceramic DD104 SL 270J 50V
C33	4010000240	Ceramic DD104 SL 390J 50V
C34	4010000520	Ceramic DD108 B 472K 50V
C35	4040000260	Barrier Layer UZE 08X 104M
C36	4010000500	Ceramic DD104 B 102K 50V
C37	4010000280	Ceramic DD104 SL 560J 50V
C38	4510003790	Electrolytic 16 MV 10 SW
C39	4010000500	Ceramic DD104 B 102K 50V
C40	4040000150	Barrier Layer UAT 05X 472K
C41	4010000520	Ceramic DD108 B 472K 50V
C42	4010000500	Ceramic DD104 B 102K 50V
C43	4010000260	Ceramic DD104 SL 470J 50V
C44	4010000270	Ceramic DD104 SL 510J 50V
C45	4010000300	Ceramic DD104 SL 680J 50V
C46	4010000020	Ceramic DD104 SL 010C 50V
C47	4010004640	Ceramic DD104 SL 130J 50V
C48	4010000300	Ceramic DD104 SL 680J 50V
C49	4010000340	Ceramic DD105 SL 121J 50V
C50	4010000330	Ceramic DD105 SL 101J 50V
C51	4010000520	Ceramic DD108 B 472K 50V
C52	4010000520	Ceramic DD108 B 472K 50V
C53	4040000260	Barrier Layer UZE 08X 104M
C54	4010000380	Ceramic DD107 SL 221J 50V
C55	4010000520	Ceramic DD108 B 472K 50V
C56	4510003780	Electrolytic 10 MV 100 SW
C57	4040000430	Barrier Layer RAU 05SA 221K
C58	4010000080	Ceramic DD104 SL 080D 50V
C59	4040000430	Barrier Layer RAU 05SA 221K
C60	4010000380	Ceramic DD107 SL 221J 50V
C61	4010000060	Ceramic DD104 SL 040C 50V
C62	4010000020	Ceramic DD104 SL 010C 50V
C63	4510003980	Electrolytic 10 MV 100 HWS (5X11)
C64	4010000500	Ceramic DD104 B 102K 50V
C65	4550000350	Tantalum DN 1V 010M
C66	4550000350	Tantalum DN 1V 010M
C67	4010000520	Ceramic DD108 B 472K 50V
C68	4010000500	Ceramic DD104 B 102K 50V
C69	4010004640	Ceramic DD305 F 104Z 12V
C70	4010000520	Ceramic DD108 B 472K 50V
C71	4010000500	Ceramic DD104 B 102K 50V
C72	4010000180	Ceramic DD104 SL 220J 50V
C73	4010000380	Ceramic DD107 SL 221J 50V
C74	4010000380	Ceramic DD107 SL 221J 50V
C75	4010000380	Ceramic DD107 SL 221J 50V
C76	4010000520	Ceramic DD108 B 472K 50V
C77	4010000520	Ceramic DD108 B 472K 50V
C78	4010000140	Ceramic DD104 SL 120J 50V
C79	4010000380	Ceramic DD107 SL 221J 50V
C80	4040000480	Barrier Layer RAU 04AK R75C
C81	4010000150	Ceramic DD104 SL 150J 50V
C82	4010000460	Ceramic DD104 B 471K 50V
C83	4010000520	Ceramic DD108 B 472K 50V
C84	4010000240	Ceramic DD104 SL 390J 50V
C85	4010000300	Ceramic DD104 SL 680J 50V
C86	4010000240	Ceramic DD104 SL 390J 50V
C87	4040000260	Barrier Layer UZE 08X 104M
C88	4010000500	Ceramic DD104 B 102K 50V
C89	4010000500	Ceramic DD104 B 102K 50V
C90	4010000070	Ceramic DD104 SL 050C 50V
C91	4010000520	Ceramic DD108 B 472K 50V
C92	4010000520	Ceramic DD108 B 472K 50V
C96	4040000430	Barrier Layer RAU 05SA 221K
C97	4040000260	Barrier Layer UZE 08X 104M
C98	4550002450	Tantalum DN 1V 1R5M
C99	4010000720	Ceramic DD104 CH 120J 50V
C100	4010000820	Ceramic DD105 CH 330J 50V
C101	4010000660	Ceramic DD104 CH 060D 50V
C102	4510003880	Electrolytic 10 MV 47 HW
C103	4010000520	Ceramic DD108 B 472K 50V
C105	4020000010	Cylinder UP125 SL 010M
C109	4010000520	Ceramic DD108 B 472K 50V

[PLL-A UNIT]

REF. NO.	ORDER NO.	DESCRIPTION	
C110	4510003780	Electrolytic	10 MV 100 SW
C111	4010000600	Ceramic	DD104 CK 010C 50V
C115	4510003920	Electrolytic	16 MV 100 HW
C116	4510003890	Electrolytic	16 MV 10 HW
C117	4010000500	Ceramic	DD104 B 102K 50V
C118	4510003790	Electrolytic	16 MV 10 SW
C119	4040000150	Barrier Layer	UAT 05X 472K
C120	4010000520	Ceramic	DD108 B 472K 50V
C121	4610000800	Trimmer	CV38B 0601
C122	4010000770	Ceramic	DD104 CH 200J 50V
C123	4010000630	Ceramic	DD104 CJ 030C 50V
C125	4010000520	Ceramic	DD108 B 472K 50V
C126	4010000520	Ceramic	DD108 B 472K 50V
C127	4010000140	Ceramic	DD104 SL 120J 50V
C130	4010000500	Ceramic	DD104 B 102K 50V
C131	4010003760	Ceramic	DD104 CK 0R5C 50V
C133	4510003790	Electrolytic	16 MV 10 SW
C134	4010000520	Ceramic	DD108 B 472K 50V
C135	4010000080	Ceramic	DD104 SL 060D 50V
C148	4010000500	Ceramic	DD104 B 102K 50V
C149	4040000260	Barrier Layer	UZE 08X 104M
C150	4010000120	Ceramic	DD104 SL 100D 50V
C154	4010000520	Ceramic	DD108 B 472K 50V
C155	4010000520	Ceramic	DD108 B 472K 50V
C156	4040000260	Barrier Layer	UZE 08X 104M
C158	4010000520	Ceramic	DD108 B 472K 50V
C159	4040000260	Barrier Layer	UZE 08X 104M
C161	4040000260	Barrier Layer	UZE 08X 104M
C162	4010000520	Ceramic	DD108 B 472K 50V
C163	4040000260	Barrier Layer	UZE 08X 104M
C165	4510003960	Electrolytic	50 MV 1 HW
C170	4040000260	Barrier Layer	UZE 08X 104M
C171	4010000040	Ceramic	DD104 SL 020C 50V
C172	4010000020	Ceramic	DD104 SL 010C 50V
C173	4010000020	Ceramic	DD104 SL 010C 50V
C175	4510003890	Electrolytic	16 MV 10 HW
C176	4010000520	Ceramic	DD108 B 472K 50V
C177	4510003790	Electrolytic	16 MV 10 SW
C181	4040000260	Barrier Layer	UZE 08X 104M
C182	4010000520	Ceramic	DD108 B 472K 50V
C185	4040000150	Barrier Layer	UAT 05X 472K
C186	4040000260	Barrier Layer	UZE 08X 104M
C187	4510003890	Electrolytic	16 MV 10 HW
C188	4040000260	Barrier Layer	UZE 08X 104M
C191	4010000050	Ceramic	DD104 SL 030C 50V
C192	4010000460	Ceramic	DD104 B 471K 50V
C193	4010000460	Ceramic	DD104 B 471K 50V
C194	4010000460	Ceramic	DD104 B 471K 50V
C195	4010000460	Ceramic	DD104 B 471K 50V
C197	4040000260	Barrier Layer	UZE 08X 104M
C203	4010004640	Ceramic	DD104 SL 130J 50V
C204	4010000150	Ceramic	DD104 SL 150J 50V
EP1	0910023964	P.C. Board	B 2115D (PLL-A)
EP2	6910000630	Bead core	FSOH070RN

[430 DDS UNIT]

REF. NO.	ORDER NO.	DESCRIPTION	
IC1	1140000500	IC	SC1051
IC2	1130005570	IC	SC1052
IC3	1130005580	IC	SC1053
IC4	1130002461	IC	TC74HCT374AF
IC5	1130002461	IC	TC74HCT374AF
IC6	1130003830	IC	TC7S04F (TE85R)
X1	6050003230	Crystal	CR-180

[430 DDS UNIT]

REF. NO.	ORDER NO.	DESCRIPTION	
L1	6200000040	Coil	LQN 5N 331K
L2	6200000040	Coil	LQN 5N 331K
L3	6200000040	Coil	LQN 5N 331K
R1	7030000740	Resistor	MCR10EZHZJ 1 MΩ (105)
R2	7030000360	Resistor	MCR10EZHZJ 680 Ω (681)
R3	7030000420	Resistor	MCR10EZHZJ 2.2 kΩ (222)
R4	7410000320	Resistor Array	GF 5096
R5	7030000500	Resistor	MCR10EZHZJ 10 kΩ (103)
R6	7030000500	Resistor	MCR10EZHZJ 10 kΩ (103)
R7	7030000500	Resistor	MCR10EZHZJ 10 kΩ (103)
C1	4610000520	Trimmer	TZB04N100BA006
C2	4030000950	Ceramic	GRM40 CH 330J 50P T
C3	4030001150	Ceramic	GRM40 F 104Z 25PT
C7	4030000720	Ceramic	GRM40 SL 680J 50P T
C8	4030000560	Ceramic	GRM40 SL 020C 50P T
C9	4030000750	Ceramic	GRM40 SL 121J 50P T
C10	4030000610	Ceramic	GRM40 SL 070D 50P T
C11	4030000750	Ceramic	GRM40 SL 121J 50P T
C12	4030000640	Ceramic	GRM40 SL 120J 50P T
C13	4030000720	Ceramic	GRM40 SL 680J 50P T
C14	4030001150	Ceramic	GRM40 F 104Z 25PT
C15	4030001150	Ceramic	GRM40 F 104Z 25PT
C16	4030001150	Ceramic	GRM40 F 104Z 25PT
C17	4030001150	Ceramic	GRM40 F 104Z 25PT
C18	4030002430	Ceramic	GRM40 TH 220J 50P T
C19	4030001100	Ceramic	GRM40 B 102K 50PT
C20	4030001100	Ceramic	GRM40 B 102K 50PT
C21	4030001150	Ceramic	GRM40 F 104Z 25PT
EP1	0910028230	P.C. Board	B 2853 (430 DDS)

[144 DDS UNIT]

REF. NO.	ORDER NO.	DESCRIPTION	
IC1	1140000500	IC	SC1051
IC2	1130005570	IC	SC1052
IC3	1130005580	IC	SC1053
IC4	1130002461	IC	TC74HCT374AF
IC5	1130002461	IC	TC74HCT374AF
IC6	1130003830	IC	TC7S04F (TE85R)
X1	6050003230	Crystal	CR-180
L1	6200000040	Coil	LQN 5N 331K
L2	6200000040	Coil	LQN 5N 331K
L3	6200000040	Coil	LQN 5N 331K
R1	7030000740	Resistor	MCR10EZHZJ 1 MΩ (105)
R2	7030000360	Resistor	MCR10EZHZJ 680 Ω (681)
R3	7030000420	Resistor	MCR10EZHZJ 2.2 kΩ (222)
R4	7410000320	Resistor Array	GF 5096
R5	7030000500	Resistor	MCR10EZHZJ 10 kΩ (103)
R6	7030000500	Resistor	MCR10EZHZJ 10 kΩ (103)
R7	7030000500	Resistor	MCR10EZHZJ 10 kΩ (103)
C1	4610000520	Trimmer	TZB04N100BA006
C2	4030000950	Ceramic	GRM40 CH 330J 50P T
C3	4030001150	Ceramic	GRM40 F 104Z 25PT
C7	4030000720	Ceramic	GRM40 SL 680J 50P T
C8	4030000560	Ceramic	GRM40 SL 020C 50P T
C9	4030000750	Ceramic	GRM40 SL 121J 50P T
C10	4030000610	Ceramic	GRM40 SL 070D 50P T
C11	4030000750	Ceramic	GRM40 SL 121J 50P T
C12	4030000640	Ceramic	GRM40 SL 120J 50P T
C13	4030000720	Ceramic	GRM40 SL 680J 50P T

[144 DDS UNIT]

REF. NO.	ORDER NO.	DESCRIPTION	
C14	4030001150	Ceramic	GRM40 F 104Z 25PT
C15	4030001150	Ceramic	GRM40 F 104Z 25PT
C16	4030001150	Ceramic	GRM40 F 104Z 25PT
C17	4030001150	Ceramic	GRM40 F 104Z 25PT
C18	4030002430	Ceramic	GRM40 TH 220J 50P T
C19	4030001100	Ceramic	GRM40 B 102K 50PT
C20	4030001100	Ceramic	GRM40 B 102K 50PT
C21	4030001150	Ceramic	GRM40 F 104Z 25PT
EP1	0910028230	P.C. Board	B 2853 (144 DDS)

[PLL-B UNIT]

REF. NO.	ORDER NO.	DESCRIPTION	
L15	6110001520	Coil	LA-232
L16	6110001520	Coil	LA-232
L17	6110002130	Coil	LA-383
L18	6110002010	Coil	LA-224
L19	6110001540	Coil	LA-234
L20	6180001380	Coil	LAL 02KR 1R0K
L21	6180001410	Coil	LAL 02KR 100K
L22	6110001980	Coil	LA-222
L23	6110001530	Coil	LA-233
L24	6150001310	Coil	LS-145
L25	6150001310	Coil	LS-145
L26	6180000900	Coil	LAL 03NA 101K
L27	6180000900	Coil	LAL 03NA 101K
L28	6140000580	Coil	LR-79
L29	6110001540	Coil	LA-234
L30	6180000880	Coil	LAL 03NA 100K
L31	6150001310	Coil	LS-145
L32	6180000900	Coil	LAL 03NA 101K
L33	6170000180	Coil	LW-19
L34	6110002130	Coil	LA-383
L35	6110002070	Coil	LA-227
L36	6110002040	Coil	LA-225
L37	6180002430	Coil	LAL 04NA 470K
L38	6110001520	Coil	LA-232
L39	6110002040	Coil	LA-225
L43	6110001980	Coil	LA-222
L44	6180001300	Coil	LAL 02NA 100K
L45	6180001380	Coil	LAL 02KR 1R0K
L46	6180000770	Coil	LAL 03NA 1R0M
L47	6180000770	Coil	LAL 03NA 1R0M
L48	6180000770	Coil	LAL 03NA 1R0M
L49	6180001380	Coil	LAL 02KR 1R0K
L51	6180000770	Coil	LAL 03NA 1R0M
L52	6180000770	Coil	LAL 03NA 1R0M
L53	6180000770	Coil	LAL 03NA 1R0M
L54	6180000770	Coil	LAL 03NA 1R0M
L55	6180001380	Coil	LAL 02KR 1R0K
L66	6180001380	Coil	LAL 02KR 1R0K
L67	6180001380	Coil	LAL 02KR 1R0K
L70	6140000930	Coil	LR-116
L71	6140000930	Coil	LR-116
L73	6180000900	Coil	LAL 03NA 101K
L74	6180001380	Coil	LAL 02KR 1R0K
L75	6180001380	Coil	LAL 02KR 1R0K
L76	6180001370	Coil	LAL 02KR R33K
L77	6170000220	Coil	LW-24
L78	6180000770	Coil	LAL 03NA 1R0M
L79	6180001380	Coil	LAL 02KR 1R0K
R1	7010004110	Resistor	R20J 220 Ω
R2	7010003160	Resistor	ELR20J 10 Ω
R3	7010004070	Resistor	R20J 100 Ω
R4	7010001150	Resistor	R25XJ 1 kΩ
R5	7010004160	Resistor	R20J 560 Ω
R6	7010004090	Resistor	R20J 150 Ω
R7	7010003420	Resistor	ELR20J 1.5 kΩ
R8	7010004250	Resistor	R20J 3.3 kΩ
R9	7010003320	Resistor	ELR20J 220 Ω
R10	7010003420	Resistor	ELR20J 1.5 kΩ
R11	7010003530	Resistor	ELR20J 10 kΩ
R12	7010003300	Resistor	ELR20J 150 Ω
R13	7010003920	Resistor	R20J 5.6 Ω
R14	7010004300	Resistor	R20J 6.8 kΩ
R15	7010003280	Resistor	ELR20J 100 Ω
R16	7010003330	Resistor	ELR20J 270 Ω
R17	7010003190	Resistor	ELR20J 18 Ω
R18	7010003330	Resistor	ELR20J 270 Ω
R19	7010001030	Resistor	R25XJ 100 Ω
R20	7010000940	Resistor	R25XJ 18 Ω
R21	7010004120	Resistor	R20J 270 Ω
R22	7010003460	Resistor	ELR20J 3.3 kΩ
R23	7010003580	Resistor	ELR20J 22 kΩ
R24	7010003280	Resistor	ELR20J 100 Ω
R25	7010003390	Resistor	ELR20J 820 Ω
R26	7010003390	Resistor	ELR20J 820 Ω
R27	7010003400	Resistor	ELR20J 1 kΩ
R28	7010004310	Resistor	R20J 8.2 kΩ

[PLL-B UNIT]

REF. NO.	ORDER NO.	DESCRIPTION	
IC1	1130000140	IC	TC4071BP
IC2	1130002960	IC	TC9181P
IC3	1110001560	IC	MB504LP-G
IC4	1120000100	IC	M74LS90P
IC5	1110002030	IC	TA7808S
IC6	1180000010	IC	TA78L005AP
IC7	1790000050	IC	ND487C1-3R
Q1	1560000130	FET	2SK125
Q2	1530002210	Transistor	2SC3776-D
Q3	1530000150	Transistor	2SC2668-O
Q4	1590000360	Transistor	RN2202
Q5	1590000340	Transistor	RN1202
Q6	1530002210	Transistor	2SC3776-D
Q7	1530000150	Transistor	2SC2668-O
Q8	1530000150	Transistor	2SC2668-O
Q9	1530002210	Transistor	2SC3776-D
Q10	1590000340	Transistor	RN1202
Q11	1530000940	Transistor	2SC1571G
Q12	1530000940	Transistor	2SC1571G
Q13	1560000130	FET	2SK125
Q14	1530000940	Transistor	2SC1571G
Q15	1510000070	Transistor	2SA1048-Y
Q16	1530000150	Transistor	2SC2668-O
Q17	1530000591	Transistor	2SC2785 EL
Q18	1530000150	Transistor	2SC2668-O
Q19	1530000150	Transistor	2SC2668-O
Q20	1580000110	FET	3SK74 M
Q21	1530000150	Transistor	2SC2668-O
Q24	1530000591	Transistor	2SC2785 EL
Q25	1560000090	FET	2SK192A-GR
Q27	1530000150	Transistor	2SC2668-O
D2	1720000290	Varicap	1T32
D3	1710000050	Diode	1SS53
D4	1710000160	Diode	1SS133
D6	1710000160	Diode	1SS133
D9	1720000060	Varicap	1SV50(1)E
L1	6140000580	Coil	LR-79
L2	6180001380	Coil	LAL 02KR 1R0K
L3	6110001530	Coil	LA-233
L4	6150000990	Coil	LS-114
L5	6150000990	Coil	LS-114
L6	6110001660	Coil	LA-252
L7	6110001980	Coil	LA-222
L8	6180002400	Coil	LAL 02NA 1R0K
L9	6180000770	Coil	LAL 03NA 1R0M
L10	6180002400	Coil	LAL 02NA 1R0K
L11	6180000730	Coil	LAL 03NA R47M
L12	6180001410	Coil	LAL 02KR 100K
L13	6110001520	Coil	LA-232
L14	6180000770	Coil	LAL 03NA 1R0M

[PLL-B UNIT]

REF. NO.	ORDER NO.	DESCRIPTION
R29	7010004280	Resistor R20J 5.6 kΩ
R30	7010003580	Resistor ELR20J 22 kΩ
R31	7010001280	Resistor R25XJ 10 kΩ
R32	7010004070	Resistor R20J 100 Ω
R33	7010003440	Resistor ELR20J 2.2 kΩ
R34	7010003400	Resistor ELR20J 1 kΩ
R35	7010003470	Resistor ELR20J 3.9 kΩ
R36	7010001030	Resistor R25XJ 100 Ω
R37	7010003950	Resistor R20J 10 Ω
R38	7010001030	Resistor R25XJ 100 Ω
R39	7010003410	Resistor ELR20J 1.2 kΩ
R40	7010003300	Resistor ELR20J 150 Ω
R42	7010003240	Resistor ELR20J 47 Ω
R43	7010003390	Resistor ELR20J 820 Ω
R44	7010003130	Resistor ELR20J 5.6 Ω
R45	7010003390	Resistor ELR20J 820 Ω
R46	7010004120	Resistor R20J 270 Ω
R47	7010003400	Resistor ELR20J 1 kΩ
R48	7010003700	Resistor ELR20J 220 kΩ
R49	7010001210	Resistor R25XJ 3.3 kΩ
R50	7010003240	Resistor ELR20J 47 Ω
R52	7010003440	Resistor ELR20J 2.2 kΩ
R53	7010003240	Resistor ELR20J 47 Ω
R54	7010004030	Resistor R20J 47 Ω
R55	7010003280	Resistor ELR20J 100 Ω
R56	7010004070	Resistor R20J 100 Ω
R57	7010003410	Resistor ELR20J 1.2 kΩ
R58	7010003620	Resistor ELR20J 47 kΩ
R59	7510000090	Thermistor ERT-D2FGL202S
R60	7010003530	Resistor ELR20J 10 kΩ
R61	7010003240	Resistor ELR20J 47 Ω
R62	7010001280	Resistor R25XJ 10 kΩ
R63	7010004070	Resistor R20J 100 Ω
R64	7010004190	Resistor R20J 1 kΩ
R65	7010003330	Resistor ELR20J 270 Ω
R66	7010003190	Resistor ELR20J 18 Ω
R67	7010003330	Resistor ELR20J 270 Ω
R68	7010003530	Resistor ELR20J 10 kΩ
R69	7010003530	Resistor ELR20J 10 kΩ
R70	7010003620	Resistor ELR20J 47 kΩ
R71	7010003480	Resistor ELR20J 4.7 kΩ
R72	7010003400	Resistor ELR20J 1 kΩ
R73	7010003580	Resistor ELR20J 22 kΩ
R74	7010003320	Resistor ELR20J 220 Ω
R76	7010004190	Resistor R20J 1 kΩ
R77	7010003620	Resistor ELR20J 47 kΩ
R79	7010003330	Resistor ELR20J 270 Ω
R80	7010003400	Resistor ELR20J 1 kΩ
R81	7010003280	Resistor ELR20J 100 Ω
R82	7010003400	Resistor ELR20J 1 kΩ
R83	7010004370	Resistor R20J 22 kΩ
R84	7010003360	Resistor ELR20J 470 Ω
R85	7010003490	Resistor ELR20J 5.6 kΩ
R86	7010004110	Resistor R20J 220 Ω
R90	7010003810	Resistor ELR20J 2.2 MΩ
R91	7010004270	Resistor R20J 4.7 kΩ
R93	7010003660	Resistor ELR20J 100 kΩ
R94	7010003660	Resistor ELR20J 100 kΩ
R95	7010003380	Resistor ELR20J 680 Ω
R96	7010004070	Resistor R20J 100 Ω
R102	7010003410	Resistor ELR20J 1.2 kΩ
R103	7010003490	Resistor ELR20J 5.6 kΩ
R104	7010003280	Resistor ELR20J 100 Ω
R105	7010003280	Resistor ELR20J 100 Ω
R106	7010003330	Resistor ELR20J 270 Ω
R107	7010003980	Resistor R20J 18 Ω
R108	7010003330	Resistor ELR20J 270 Ω
R118	7010004240	Resistor R20J 2.7 kΩ
R126	7010004120	Resistor R20J 270 Ω
R127	7010003980	Resistor R20J 18 Ω
R128	7010004120	Resistor R20J 270 Ω
R133	7510000090	Thermistor ERT-D2FGL202S
R135	7010004320	Resistor R20J 10 kΩ
R136	7010004090	Resistor R20J 150 Ω
C1	4010000660	Ceramic DD104 CH 060D 50V
C2	4010000820	Ceramic DD105 CH 330J 50V

[PLL-B UNIT]

REF. NO.	ORDER NO.	DESCRIPTION
C3	4010000460	Ceramic DD104 B 471K 50V
C4	4010000460	Ceramic DD104 B 471K 50V
C5	4510003980	Electrolytic 10 MV 100 HWS (5X11)
C6	4010000500	Ceramic DD104 B 102K 50V
C7	4010000260	Ceramic DD104 SL 470J 50V
C8	4510003980	Electrolytic 10 MV 100 HWS (5X11)
C9	4010000460	Ceramic DD104 B 471K 50V
C10	4010000460	Ceramic DD104 B 471K 50V
C11	4510003980	Electrolytic 10 MV 100 HWS (5X11)
C12	4010000500	Ceramic DD104 B 102K 50V
C13	4010000500	Ceramic DD104 B 102K 50V
C14	4010000600	Ceramic DD104 CK 010C 50V
C15	4010000140	Ceramic DD104 SL 120J 50V
C16	4010000120	Ceramic DD104 SL 100D 50V
C17	4010000500	Ceramic DD104 B 102K 50V
C18	4010000500	Ceramic DD104 B 102K 50V
C19	4010000090	Ceramic DD104 SL 070D 50V
C20	4010000040	Ceramic DD104 SL 020C 50V
C21	4010000520	Ceramic DD108 B 472K 50V
C22	4040000260	Barrier Layer UZE 08X 104M
C23	4610000770	Trimmer CV38D 1001
C24	4010000680	Ceramic DD104 CH 080D 50V
C25	4010000680	Ceramic DD104 CH 080D 50V
C26	4010000600	Ceramic DD104 CK 010C 50V
C27	4010000650	Ceramic DD104 CH 050C 50V
C28	4010000460	Ceramic DD104 B 471K 50V
C29	4010000460	Ceramic DD104 B 471K 50V
C30	4010004640	Ceramic DD104 SL 130J 50V
C31	4010000520	Ceramic DD108 B 472K 50V
C32	4010000520	Ceramic DD108 B 472K 50V
C33	4010000150	Ceramic DD104 SL 150J 50V
C34	4010000500	Ceramic DD104 B 102K 50V
C35	4040000260	Barrier Layer UZE 08X 104M
C36	4010000500	Ceramic DD104 B 102K 50V
C37	4010000670	Ceramic DD104 CH 070D 50V
C38	4010000650	Ceramic DD104 CH 050C 50V
C39	4010000650	Ceramic DD104 CH 050C 50V
C40	4010000330	Ceramic DD105 SL 101J 50V
C41	4010000330	Ceramic DD105 SL 101J 50V
C42	4010000520	Ceramic DD108 B 472K 50V
C43	4010000050	Ceramic DD104 SL 030C 50V
C44	4010000500	Ceramic DD104 B 102K 50V
C45	4010000500	Ceramic DD104 B 102K 50V
C46	4010000380	Ceramic DD107 SL 221J 50V
C47	4010000500	Ceramic DD104 B 102K 50V
C48	4010000260	Ceramic DD104 SL 470J 50V
C49	4010004640	Ceramic DD104 SL 130J 50V
C50	4010000270	Ceramic DD104 SL 510J 50V
C51	4010000160	Ceramic DD104 SL 180J 50V
C52	4010000240	Ceramic DD104 SL 390J 50V
C53	4020000670	Cylinder UP050 SL 470J
C54	4010000060	Ceramic DD104 SL 040C 50V
C55	4010000150	Ceramic DD104 SL 150J 50V
C56	4010000620	Ceramic DD104 CK 020C 50V
C57	4010000630	Ceramic DD104 CJ 030C 50V
C58	4010000630	Ceramic DD104 CJ 030C 50V
C59	4010000640	Ceramic DD104 CH 040C 50V
C60	4010000380	Ceramic DD107 SL 221J 50V
C61	4010000070	Ceramic DD104 SL 050C 50V
C62	4010000500	Ceramic DD104 B 102K 50V
C63	4020000470	Cylinder UP050 SL 4R7K
C64	4040000260	Barrier Layer UZE 08X 104M
C65	4010000610	Ceramic DD104 CK 1R5C 50V
C66	4010000500	Ceramic DD104 B 102K 50V
C67	4010000180	Ceramic DD104 SL 220J 50V
C68	4010004640	Ceramic DD104 SL 130J 50V
C69	4010000120	Ceramic DD104 SL 100D 50V
C70	4040000260	Barrier Layer UZE 08X 104M
C71	4010000500	Ceramic DD104 B 102K 50V
C72	4010000500	Ceramic DD104 B 102K 50V
C73	4010000500	Ceramic DD104 B 102K 50V
C74	4010000380	Ceramic DD107 SL 221J 50V
C75	4010000500	Ceramic DD104 B 102K 50V
C76	4010000520	Ceramic DD108 B 472K 50V
C77	4010000500	Ceramic DD104 B 102K 50V
C78	4010003290	Ceramic DD104 UJ 050C 50V
C79	4010000520	Ceramic DD108 B 472K 50V
C80	4040000470	Barrier Layer RAU 04AK R35C

[PLL-B UNIT]

REF. NO.	ORDER NO.	DESCRIPTION
C81	4010003290	Ceramic DD104 UJ 050C 50V
C82	4040000190	Barrier Layer UAT 05X 103K
C83	4010000500	Ceramic DD104 B 102K 50V
C84	4010000240	Ceramic DD104 SL 390J 50V
C85	4010000340	Ceramic DD105 SL 121J 50V
C86	4010000240	Ceramic DD104 SL 390J 50V
C87	4040000260	Barrier Layer UZE 08X 104M
C88	4040000190	Barrier Layer UAT 05X 103K
C89	4010000500	Ceramic DD104 B 102K 50V
C90	4010000150	Ceramic DD104 SL 150J 50V
C91	4010000500	Ceramic DD104 B 102K 50V
C92	4010000380	Ceramic DD107 SL 221J 50V
C93	4010004640	Ceramic DD104 SL 130J 50V
C94	4010000620	Ceramic DD104 CK 020C 50V
C95	4010000090	Ceramic DD104 SL 070D 50V
C96	4550000360	Tantalum DN 1V R47M
C97	4550000360	Tantalum DN 1V R47M
C98	4550002450	Tantalum DN 1V 1R5M
C99	4010001980	Ceramic DD104 RH 070D 50V
C100	4010000780	Ceramic DD104 CH 220J 50V
C101	4010000660	Ceramic DD104 CH 060D 50V
C102	4550002040	Tantalum DN 1A 330M
C103	4010000500	Ceramic DD104 B 102K 50V
C104	4010000080	Ceramic DD104 SL 060D 50V
C105	4020000010	Cylinder UP125 SL 010M
C106	4010000280	Ceramic DD104 SL 560J 50V
C107	4010000280	Ceramic DD104 SL 560J 50V
C108	4010000280	Ceramic DD104 SL 560J 50V
C109	4010000500	Ceramic DD104 B 102K 50V
C110	4510003980	Electrolytic 10 MV 100 HWS (5X11)
C111	4010000040	Ceramic DD104 SL 020C 50V
C112	4510003780	Electrolytic 10 MV 100 SW
C113	4010000280	Ceramic DD104 SL 470J 50V
C114	4010000090	Ceramic DD104 SL 070D 50V
C115	4510003920	Electrolytic 16 MV 100 HW
C116	4510003890	Electrolytic 16 MV 10 HW
C117	4010000500	Ceramic DD104 B 102K 50V
C118	4510003890	Electrolytic 16 MV 10 HW
C119	4010000640	Ceramic DD104 CH 040C 50V
C120	4010000500	Ceramic DD104 B 102K 50V
C121	4610001130	Trimmer CVSSA1001
C122	4010002400	Ceramic DD104 SH 070D 50V
C123	4010000630	Ceramic DD104 CJ 030C 50V
C124	4010000280	Ceramic DD104 SL 470J 50V
C125	4010000380	Ceramic DD107 SL 221J 50V
C126	4010000380	Ceramic DD107 SL 221J 50V
C127	4010000080	Ceramic DD104 SL 040C 50V
C128	4010000800	Ceramic DD105 CH 270J 50V
C129	4010000280	Ceramic DD104 SL 470J 50V
C130	4010000280	Ceramic DD104 SL 470J 50V
C131	4010000500	Ceramic DD104 B 102K 50V
C132	4010000500	Ceramic DD104 B 102K 50V
C133	4010000380	Ceramic DD107 SL 221J 50V
C134	4010000520	Ceramic DD108 B 472K 50V
C135	4510003980	Electrolytic 10 MV 100 HWS (5X11)
C136	4010000520	Ceramic DD108 B 472K 50V
C137	4040000260	Barrier Layer UZE 08X 104M
C138	4010000150	Ceramic DD104 SL 150J 50V
C139	4040000260	Barrier Layer UZE 08X 104M
C140	4010000140	Ceramic DD104 SL 120J 50V
C141	4010000700	Ceramic DD104 CH 100D 50V
C142	4010000260	Ceramic DD104 SL 470J 50V
C143	4010000260	Ceramic DD104 SL 470J 50V
C144	4010000260	Ceramic DD104 SL 470J 50V
C148	4010000500	Ceramic DD104 B 102K 50V
C149	4040000260	Barrier Layer UZE 08X 104M
C151	4010000280	Ceramic DD104 SL 470J 50V
C154	4510003790	Electrolytic 16 MV 10 SW
C155	4510003790	Electrolytic 16 MV 10 SW
C156	4040000260	Barrier Layer UZE 08X 104M
C158	4010000500	Ceramic DD104 B 102K 50V
C160	4010000260	Ceramic DD104 SL 470J 50V
C161	4010000380	Ceramic DD107 SL 221J 50V
C165	4020000650	Cylinder EP050 X 472M
C167	4010000160	Ceramic DD104 SL 180J 50V
C168	4010000160	Ceramic DD104 SL 180J 50V
C170	4040000260	Barrier Layer UZE 08X 104M
C171	4010000380	Ceramic DD107 SL 221J 50V

[PLL-B UNIT]

REF. NO.	ORDER NO.	DESCRIPTION
C172	4010000220	Ceramic DD104 SL 330J 50V
C173	4010000500	Ceramic DD104 B 102K 50V
C174	4040000260	Barrier Layer UZE 08X 104M
C175	4510003790	Electrolytic 16 MV 10 SW
C179	4010000140	Ceramic DD104 SL 120J 50V
C180	4010000070	Ceramic DD104 SL 050C 50V
C181	4040000260	Barrier Layer UZE 08X 104M
C182	4010000500	Ceramic DD104 B 102K 50V
C185	4010000500	Ceramic DD104 B 102K 50V
C186	4040000260	Barrier Layer UZE 08X 104M
C187	4010000260	Ceramic DD104 SL 470J 50V
C188	4040000260	Barrier Layer UZE 08X 104M
C189	4010000500	Ceramic DD104 B 102K 50V
C190	4010000520	Ceramic DD108 B 472K 50V
C191	4010000260	Ceramic DD104 SL 470J 50V
C192	4010000500	Ceramic DD104 B 102K 50V
C193	4010000460	Ceramic DD104 B 471K 50V
C194	4010000460	Ceramic DD104 B 471K 50V
C195	4010000460	Ceramic DD104 B 471K 50V
C196	4010000460	Ceramic DD104 B 471K 50V
C207	4010000500	Ceramic DD104 B 102K 50V
C209	4010000260	Ceramic DD104 SL 470J 50V
C210	4010000080	Ceramic DD104 SL 040C 50V
C214	4020000400	Cylinder UP050 B 102K
C216	4010000500	Ceramic DD104 B 102K 50V
C219	4010000140	Ceramic DD104 SL 120J 50V
C221	4040000260	Barrier Layer UZE 08X 104M
C222	4510003860	Electrolytic 50 MV 3R3 SW
C223	4010000120	Ceramic DD104 SL 100D 50V
C224	4040000260	Barrier Layer UZE 08X 104M
EP1	0910024185	P.C. Board B 2116E (PLL-B)
EP2	6910000630	Bead core FSOH070RN

[OSC UNIT]

REF. NO.	ORDER NO.	DESCRIPTION
IC	1110002030	IC TA7808S
Q1	1530000591	Transistor 2SC2785 EL
Q2	1530000591	Transistor 2SC2785 EL
Q3	1530000591	Transistor 2SC2785 EL
Q4	1530000591	Transistor 2SC2785 EL
Q5	1530000591	Transistor 2SC2785 EL
L1	6910000670	Coil BT01RN1-A61-001
L2	6180001410	Coil LAL 02KR 100K
L3	6180000880	Coil LAL 03NA 100K
L4	6180000880	Coil LAL 03NA 100K
L5	6180000880	Coil LAL 03NA 100K
L6	6180000880	Coil LAL 03NA 100K
L7	6180000880	Coil LAL 03NA 100K
R1	7010004030	Resistor R20J 47 Ω
R2	7010003580	Resistor ELR20J 22 kΩ
R3	7010003530	Resistor ELR20J 10 kΩ
R4	7010004030	Resistor R20J 47 Ω
R5	7010004110	Resistor R20J 220 Ω
R6	7010003580	Resistor ELR20J 22 kΩ
R7	7010004320	Resistor R20J 10 kΩ
R8	7010004030	Resistor R20J 47 Ω
R9	7010003240	Resistor ELR20J 47 Ω
R10	7010003580	Resistor ELR20J 22 kΩ
R11	7010004320	Resistor R20J 10 kΩ
R12	7010004030	Resistor R20J 47 Ω

[OSC UNIT]

REF. NO.	ORDER NO.	DESCRIPTION	
R13	7010004320	Resistor	R20J 10 kΩ
R14	7010003580	Resistor	ELR20J 22 kΩ
R15	7010004320	Resistor	R20J 10 kΩ
R16	7010004030	Resistor	R20J 47 Ω
R17	7010003580	Resistor	ELR20J 22 kΩ
R18	7010003320	Resistor	ELR20J 220 Ω
R21	7010003320	Resistor	ELR20J 220 Ω
R24	7010003320	Resistor	ELR20J 220 Ω
R27	7010003320	Resistor	ELR20J 220 Ω
C1	4010000520	Ceramic	DD108 B 472K 50V
C2	4040000260	Barrier Layer	UZE 08X 104M
C3	4510003890	Electrolytic	16 MV 10 HW
C4	4010000500	Ceramic	DD104 B 102K 50V
C5	4010000520	Ceramic	DD108 B 472K 50V
C6	4510003920	Electrolytic	16 MV 100 HW
C7	4040000260	Barrier Layer	UZE 08X 104M
C8	4010000520	Ceramic	DD108 B 472K 50V
C9	4510003890	Electrolytic	16 MV 10 HW
C10	4010000500	Ceramic	DD104 B 102K 50V
C11	4010000520	Ceramic	DD108 B 472K 50V
C12	4010000500	Ceramic	DD104 B 102K 50V
C13	4010000520	Ceramic	DD108 B 472K 50V
C14	4010000500	Ceramic	DD104 B 102K 50V
C15	4010000520	Ceramic	DD108 B 472K 50V
C16	4010000500	Ceramic	DD104 B 102K 50V
C17	4010000520	Ceramic	DD108 B 472K 50V
C18	4010000500	Ceramic	DD104 B 102K 50V
C19	4010000520	Ceramic	DD108 B 472K 50V
C20	4010000500	Ceramic	DD104 B 102K 50V
C22	4010000330	Ceramic	DD105 SL 101J 50V
C23	4010000330	Ceramic	DD105 SL 101J 50V
C24	4010000330	Ceramic	DD105 SL 101J 50V
C25	4010000330	Ceramic	DD105 SL 101J 50V
C26	4010000330	Ceramic	DD105 SL 101J 50V
C27	4010000260	Ceramic	DD104 SL 470J 50V
C28	4010000260	Ceramic	DD104 SL 470J 50V
C29	4010000260	Ceramic	DD104 SL 470J 50V
C30	4010000260	Ceramic	DD104 SL 470J 50V
C31	4010000260	Ceramic	DD104 SL 470J 50V
EP1	0910024233	P.C. Board	B 2232C (OSC)

[OSC (B) UNIT]

REF. NO.	ORDER NO.	DESCRIPTION	
IC1	1180000620	IC	TA78L05S
Q1	1530000150	Transistor	2SC2668-O
Q2	1530000150	Transistor	2SC2668-O
X1	6050006490	Crystal	CR-292
L1	6180000880	Coil	LAL 03NA 100K
L2	6180000880	Coil	LAL 03NA 100K
L3	6180000770	Coil	LAL 03NA 1R0M
L4	6180001300	Coil	LAL 02NA 100K
R1	7010003470	Resistor	ELR20J 3.9 kΩ
R2	7010004210	Resistor	R20J 1.5 kΩ
R3	7010003320	Resistor	ELR20J 220 Ω
R4	7010003280	Resistor	ELR20J 100 Ω
R5	7010004300	Resistor	R20J 6.8 kΩ

[OSC (B) UNIT]

REF. NO.	ORDER NO.	DESCRIPTION	
R6	7010001180	Resistor	R25XJ 1.8 kΩ
C1	4010000500	Ceramic	DD104 B 102K 50V
C2	4010000520	Ceramic	DD108 B 472K 50V
C3	4510003890	Electrolytic	16 MV 10 HW
C4	4010000520	Ceramic	DD108 B 472K 50V
C5	4010004840	Ceramic	DD305 F 104Z 12V
C6	4010000670	Ceramic	DD104 CH 070D 50V
C7	4610000110	Trimmer	CV05C1201
C8	4010000940	Ceramic	DD107 CH 101J 50V
C9	4010000940	Ceramic	DD107 CH 101J 50V
C10	4010000630	Ceramic	DD104 CJ 030C 50V
C11	4010000520	Ceramic	DD108 B 472K 50V
C12	4010000520	Ceramic	DD108 B 472K 50V
EP1	0910024225	P.C. Board	B 2233E (OSC(B))

[CTRL UNIT]

REF. NO.	ORDER NO.	DESCRIPTION	
IC1	1110002040	IC	TA7809S
Q1	1590000340	Transistor	RN1202
Q2	1590000340	Transistor	RN1202
Q3	1590000340	Transistor	RN1202
Q4	1590000340	Transistor	RN1202
Q5	1590000340	Transistor	RN1202
Q6	1590000340	Transistor	RN1202
Q7	1510000680	Transistor	2SA683-R
Q8	1510000680	Transistor	2SA683-R
Q9	1510000680	Transistor	2SA683-R
Q10	1510000680	Transistor	2SA683-R
Q11	1590000340	Transistor	RN1202
Q12	1530002650	Transistor	2SC1384-R
Q13	1530000591	Transistor	2SC2785 EL
Q14	1530002590	Transistor	2SC3422-Y
Q15	1530002590	Transistor	2SC3422-Y
Q16	1590000340	Transistor	RN1202
Q17	1590000340	Transistor	RN1202
Q18	1590000340	Transistor	RN1202
Q19	1590000340	Transistor	RN1202
Q20	1590000340	Transistor	RN1202
Q21	1590000340	Transistor	RN1202
Q22	1510000680	Transistor	2SA683-R
Q23	1510000680	Transistor	2SA683-R
Q24	1510000680	Transistor	2SA683-R
Q25	1510000680	Transistor	2SA683-R
Q26	1590000340	Transistor	RN1202
Q27	1530002650	Transistor	2SC1384-R
Q28	1530002590	Transistor	2SC3422-Y
Q29	1530000591	Transistor	2SC2785 EL
Q30	1530002590	Transistor	2SC3422-Y
D1	1710000160	Diode	1SS133
D2	1710000160	Diode	1SS133
D3	1710000160	Diode	1SS133
D4	1710000160	Diode	1SS133
D5	1710000160	Diode	1SS133
D6	1710000050	Diode	1SS53 (IC-970/970M)
	1710000160	Diode	1SS133 (IC-970D)
D9	1710000160	Diode	1SS133
D10	1710000160	Diode	1SS133
D11	1710000160	Diode	1SS133
D12	1710000160	Diode	1SS133
D13	1710000160	Diode	1SS133 (IC-970D only)

[CTRL UNIT]

REF. NO.	ORDER NO.	DESCRIPTION	
D14	1710000160	Diode	1SS133 (IC-970D only)
R1	7010003620	Resistor	ELR20J 47 kΩ
R2	7010003480	Resistor	ELR20J 4.7 kΩ
R3	7010003480	Resistor	ELR20J 4.7 kΩ
R4	7010003620	Resistor	ELR20J 47 kΩ
R5	7010003620	Resistor	ELR20J 47 kΩ
R6	7010004270	Resistor	R20J 4.7 kΩ
R7	7010004230	Resistor	R20J 2.2 kΩ
R8	7010004270	Resistor	R20J 4.7 kΩ
R9	7010004230	Resistor	R20J 2.2 kΩ
R10	7010004270	Resistor	R20J 4.7 kΩ
R11	7010004230	Resistor	R20J 2.2 kΩ
R12	7010004270	Resistor	R20J 4.7 kΩ
R13	7010004230	Resistor	R20J 2.2 kΩ
R14	7310000770	Trimmer	RH0651CN4J0TA (IC-970)
	7310000720	Trimmer	RH0651CJ3J0CA (222) (IC-970M)
	7310000740	Trimmer	RH0651CS3J2KA (472) (IC-970D)
R15	7310000770	Trimmer	RH0651CN4J0TA (IC-970)
	7310000720	Trimmer	RH0651CJ3J0CA (222) (IC-970M)
	7310000740	Trimmer	RH0651CS3J2KA (472) (IC-970D)
R16	7010004640	Resistor	R50XJ 3.3 Ω
R17	7010004250	Resistor	R20J 3.3 kΩ
R18	7010004150	Resistor	R20J 470 Ω
R19	7010003480	Resistor	ELR20J 4.7 kΩ
R20	7010004770	Resistor	R50XJ 330 Ω
R21	7010003620	Resistor	ELR20J 47 kΩ
R22	7010003480	Resistor	ELR20J 4.7 kΩ
R23	7010003480	Resistor	ELR20J 4.7 kΩ
R24	7010003620	Resistor	ELR20J 47 kΩ
R25	7010003620	Resistor	ELR20J 47 kΩ
R26	7010004270	Resistor	R20J 4.7 kΩ
R27	7010004230	Resistor	R20J 2.2 kΩ
R28	7010004270	Resistor	R20J 4.7 kΩ
R29	7010004230	Resistor	R20J 2.2 kΩ
R30	7010004270	Resistor	R20J 4.7 kΩ
R31	7010004230	Resistor	R20J 2.2 kΩ
R32	7010004270	Resistor	R20J 4.7 kΩ
R33	7010004230	Resistor	R20J 2.2 kΩ
R34	7010004250	Resistor	R20J 3.3 kΩ
R35	7010004150	Resistor	R20J 470 Ω
R36	7010004640	Resistor	R50XJ 3.3 Ω
R37	7010004770	Resistor	R50XJ 330 Ω
R38	7010004270	Resistor	R20J 4.7 kΩ
R39	7010001360	Resistor	R25XJ 47 kΩ
R40	7010003400	Resistor	ELR20J 1 kΩ (IC-970/970D)
	7010003380	Resistor	ELR20J 470 Ω (IC-970M)
R41	7010003400	Resistor	ELR20J 1 kΩ (IC-970/970D)
	7010003380	Resistor	ELR20J 470 Ω (IC-970M)
C1	4010000500	Ceramic	DD104 B 102K 50V
C2	4010000500	Ceramic	DD104 B 102K 50V (IC-970D only)
C3	4010000500	Ceramic	DD104 B 102K 50V
C4	4010000500	Ceramic	DD104 B 102K 50V
C5	4010000500	Ceramic	DD104 B 102K 50V
C6	4010000500	Ceramic	DD104 B 102K 50V
C7	4010000500	Ceramic	DD104 B 102K 50V
C8	4010000500	Ceramic	DD104 B 102K 50V
C9	4510003900	Electrolytic	16 MV 22 HW
C10	4010000500	Ceramic	DD104 B 102K 50V
C11	4010000500	Ceramic	DD104 B 102K 50V
C12	4010000520	Ceramic	DD108 B 472K 50V
C13	4010000500	Ceramic	DD104 B 102K 50V
C14	4510003960	Electrolytic	50 MV 1 HW

[CTRL UNIT]

REF. NO.	ORDER NO.	DESCRIPTION	
C15	4010000500	Ceramic	DD104 B 102K 50V
C16	4010000500	Ceramic	DD104 B 102K 50V
C17	4510003970	Electrolytic	50 MV 2R2 HW
C18	4510003870	Electrolytic	10 MV 22 HW
C19	4040000260	Barrier Layer	UZE 08X 104M
C20	4040000260	Barrier Layer	UZE 08X 104M
C21	4510003900	Electrolytic	16 MV 22 HW
C22	4010000500	Ceramic	DD104 B 102K 50V
C23	4010000500	Ceramic	DD104 B 102K 50V
C24	4010000500	Ceramic	DD104 B 102K 50V
C25	4010000500	Ceramic	DD104 B 102K 50V
C26	4010000500	Ceramic	DD104 B 102K 50V
C27	4010000500	Ceramic	DD104 B 102K 50V
C28	4010000500	Ceramic	DD104 B 102K 50V
C29	4010000500	Ceramic	DD104 B 102K 50V
C30	4510003900	Electrolytic	16 MV 22 HW
C31	4010000500	Ceramic	DD104 B 102K 50V
C32	4010000500	Ceramic	DD104 B 102K 50V
C33	4510003960	Electrolytic	50 MV 1 HW
C34	4010000520	Ceramic	DD108 B 472K 50V
C35	4010000500	Ceramic	DD104 B 102K 50V
C36	4010000500	Ceramic	DD104 B 102K 50V
C37	4010000500	Ceramic	DD104 B 102K 50V
C38	4510003970	Electrolytic	50 MV 2R2 HW
C39	4010000500	Ceramic	DD104 B 102K 50V
C40	4010000500	Ceramic	DD104 B 102K 50V
C41	4010000500	Ceramic	DD104 B 102K 50V
C42	4010000500	Ceramic	DD104 B 102K 50V
C43	4010000500	Ceramic	DD104 B 102K 50V
C44	4010000500	Ceramic	DD104 B 102K 50V
EP1	0910022794	P.C. Board	B 2225D (CTRL)

[PA UNIT]

REF. NO.	ORDER NO.	DESCRIPTION	
IC1	1150000830	IC	SC1113 (IC-970D)
	1150000160	IC	SC1020 (IC-970M)
	1150000110	IC	SC1013 (IC-970)
IC2	1150000840	IC	SC1114 (IC-970D)
	1150000170	IC	SC1024 (IC-970M)
	1150000140	IC	SC1016 (IC-970)
IC3	1150000140	IC	SC1016 (IC-970D only)
S1	6910000070	Thermostat	OHD-3 80M

[430 PA H UNIT]

REF. NO.	ORDER NO.	DESCRIPTION	
D1	1790000070	Diode	1SS237
D2	1790000070	Diode	1SS237
D3	1790000070	Diode	1SS237
D4	1790000070	Diode	1SS237
D6	1710000310	Diode	MI407
D7	1710000290	Diode	MI308
D8	1710000290	Diode	MI308
L1	6110001520	Coil	LA-232
L2	6110001600	Coil	LA-243
L4	6110001520	Coil	LA-232
L5	6110001570	Coil	LA-237
L6	6110001570	Coil	LA-237
L7	6110001520	Coil	LA-232
L8	6110001520	Coil	LA-232
L9	6110001520	Coil	LA-232
L10	6910000670	Coil	BT01RN1-A61-001
L11	6910000670	Coil	BT01RN1-A61-001
L12	6180000880	Coil	LAL 03NA 100K
L13	6170000180	Coil	LW-19
L14	6180000880	Coil	LAL 03NA 100K
R1	7100000510	Resistor	CP-5AJ 0.012 Ω
R2	7010004190	Resistor	R20J 1 kΩ
R3	7010003400	Resistor	ELR20J 1 kΩ
R4	7010004270	Resistor	R20J 4.7 kΩ
R5	7010003480	Resistor	ELR20J 4.7 kΩ
R6	7010003480	Resistor	ELR20J 4.7 kΩ
R9	7010004740	Resistor	R50XJ 150 Ω
R10	7010004740	Resistor	R50XJ 150 Ω
R11	7010004320	Resistor	R20J 10 kΩ
R12	7010004200	Resistor	R20J 1.2 kΩ
R13	7010004320	Resistor	R20J 10 kΩ
R14	7010004200	Resistor	R20J 1.2 kΩ
C1	4510003930	Electrolytic	16 MV 470 HW
C2	4010000500	Ceramic	DD104 B 102K 50V
C3	4010000260	Ceramic	DD104 SL 470J 50V
C4	4010000500	Ceramic	DD104 B 102K 50V
C5	4010000260	Ceramic	DD104 SL 470J 50V
C6	4510003930	Electrolytic	16 MV 470 HW
C7	4010000500	Ceramic	DD104 B 102K 50V
C8	4010000260	Ceramic	DD104 SL 470J 50V
C9	4010000500	Ceramic	DD104 B 102K 50V
C10	4010000260	Ceramic	DD104 SL 470J 50V
C11	4010000260	Ceramic	DD104 SL 470J 50V
C12	4010000260	Ceramic	DD104 SL 470J 50V
C13	4010000260	Ceramic	DD104 SL 470J 50V
C14	4010000260	Ceramic	DD104 SL 470J 50V
C15	4010003800	Ceramic	DD06 SL 030C 500V
C20	4010000500	Ceramic	DD104 B 102K 50V
C21	4010000500	Ceramic	DD104 B 102K 50V
C22	4010003840	Ceramic	DD06 SL 070D 500V
C23	4010003820	Ceramic	DD06 SL 050C 500V
C24	4010003880	Ceramic	DD06 SL 150K 500V
C25	4010003870	Ceramic	DD06 SL 120K 500V
C26	4010003880	Ceramic	DD06 SL 150K 500V
C27	4010003790	Ceramic	DD06 SL 020C 500V
C28	4010003780	Ceramic	DD06 SL 010C 500V
C29	4010003850	Ceramic	DD06 SL 080D 500V
C30	4010003810	Ceramic	DD06 SL 040C 500V
C31	4010000260	Ceramic	DD104 SL 470J 50V
C32	4010000500	Ceramic	DD104 B 102K 50V
C36	4010000500	Ceramic	DD104 B 102K 50V
C37	4010000110	Ceramic	DD104 SL 090D 50V
C38	4010000050	Ceramic	DD104 SL 030C 50V
C39	4010000500	Ceramic	DD104 B 102K 50V
C40	4010000520	Ceramic	DD108 B 472K 50V
C41	4010000500	Ceramic	DD104 B 102K 50V
C42	4010000260	Ceramic	DD104 SL 470J 50V
C43	4510003890	Electrolytic	16 MV 10 HW
C44	4010000500	Ceramic	DD104 B 102K 50V
C45	4010000500	Ceramic	DD104 B 102K 50V
C46	4010003810	Ceramic	DD06 SL 040C 500V
C47	4010003810	Ceramic	DD06 SL 040C 500V

[430 PA H UNIT]

REF. NO.	ORDER NO.	DESCRIPTION	
C48	4010003820	Ceramic	DD06 SL 050C 500V
C49	4010000500	Ceramic	DD104 B 102K 50V
EP1	0910023075	P.C. Board	B 2212E (430 PA H)

[144 PA H UNIT]

REF. NO.	ORDER NO.	DESCRIPTION	
D1	1790000070	Diode	1SS237
D2	1790000070	Diode	1SS237
D3	1790000070	Diode	1SS237
D4	1790000070	Diode	1SS237
D6	1710000310	Diode	MI407
D7	1710000290	Diode	MI308
D8	1710000290	Diode	MI308
L1	6110001740	Coil	LA-263
L2	6110001740	Coil	LA-263
L3	6110001740	Coil	LA-263
L4	6110001670	Coil	LA-253
L5	6170000180	Coil	LW-19
L6	6170000070	Coil	LW-9
L7	6170000180	Coil	LW-19
L8	6110001550	Coil	LA-235
L9	6110001550	Coil	LA-235
L10	6910000670	Coil	BT01RN1-A61-001
L11	6910000670	Coil	BT01RN1-A61-001
R1	7100000510	Resistor	CP-5AJ 0.012 Ω
R2	7010004190	Resistor	R20J 1 kΩ
R3	7010003400	Resistor	ELR20J 1 kΩ
R4	7010003480	Resistor	ELR20J 4.7 kΩ
R5	7010003480	Resistor	ELR20J 4.7 kΩ
R8	7010004740	Resistor	R50XJ 150 Ω
R9	7010004740	Resistor	R50XJ 150 Ω
R10	7010004320	Resistor	R20J 10 kΩ
R11	7010004200	Resistor	R20J 1.2 kΩ
R12	7010004320	Resistor	R20J 10 kΩ
R13	7010004200	Resistor	R20J 1.2 kΩ
C1	4510003930	Electrolytic	16 MV 470 HW
C2	4010000520	Ceramic	DD108 B 472K 50V
C3	4010000500	Ceramic	DD104 B 102K 50V
C4	4010000520	Ceramic	DD108 B 472K 50V
C5	4010000500	Ceramic	DD104 B 102K 50V
C6	4510003930	Electrolytic	16 MV 470 HW
C7	4010000520	Ceramic	DD108 B 472K 50V
C8	4010000500	Ceramic	DD104 B 102K 50V
C9	4010000380	Ceramic	DD107 SL 221J 50V
C10	4010000500	Ceramic	DD104 B 102K 50V
C11	4010000380	Ceramic	DD107 SL 221J 50V
C12	4010000380	Ceramic	DD107 SL 221J 50V
C13	4010000380	Ceramic	DD107 SL 221J 50V
C14	4010003880	Ceramic	DD06 SL 150K 500V
C19	4010000500	Ceramic	DD104 B 102K 50V
C20	4010000500	Ceramic	DD104 B 102K 50V
C21	4010003880	Ceramic	DD06 SL 150K 500V
C22	4010003880	Ceramic	DD06 SL 150K 500V
C23	4010004120	Ceramic	DD07 B 102K 500V
C24	4010003880	Ceramic	DD06 SL 150K 500V
C25	4010003950	Ceramic	DD06 SL 330K 500V
C26	4010003950	Ceramic	DD06 SL 330K 500V
C27	4010003880	Ceramic	DD06 SL 150K 500V
C28	4010004120	Ceramic	DD07 B 102K 500V

[144 PA H UNIT]

REF. NO.	ORDER NO.	DESCRIPTION	
C29	4010000380	Ceramic	DD107 SL 221J 50V
C30	4010000380	Ceramic	DD107 SL 221J 50V
C31	4010000520	Ceramic	DD108 B 472K 50V
C33	4010000380	Ceramic	DD107 SL 221J 50V
C34	4010000240	Ceramic	DD104 SL 390J 50V
C35	4010000170	Ceramic	DD104 SL 200J 50V
C36	4010000330	Ceramic	DD105 SL 101J 50V
C37	4040000250	Barrier Layer	UAT 08X 473M
C38	4010000520	Ceramic	DD108 B 472K 50V
C39	4010000380	Ceramic	DD107 SL 221J 50V
C40	4510003890	Electrolytic	16 MV 10 HW
C41	4010000500	Ceramic	DD104 B 102K 50V
C42	4010000500	Ceramic	DD104 B 102K 50V
C43	4010000500	Ceramic	DD104 B 102K 50V
EP1	0910022913	P.C. Board	B 2211C (144 PA H)
EP2	6910000630	Bead core	FSOH070RN

[144 PA L UNIT]

REF. NO.	ORDER NO.	DESCRIPTION	
C13	4010000380	Ceramic	DD107 SL 221J 50V
C14	4010003880	Ceramic	DD06 SL 150K 500V
C19	4010000500	Ceramic	DD104 B 102K 50V
C20	4010000500	Ceramic	DD104 B 102K 50V
C21	4010003880	Ceramic	DD06 SL 150K 500V
C22	4010003880	Ceramic	DD06 SL 150K 500V
C23	4010004120	Ceramic	DD07 B 102K 500V
C24	4010003880	Ceramic	DD06 SL 150K 500V
C25	4010003950	Ceramic	DD06 SL 330K 500V
C26	4010003950	Ceramic	DD06 SL 330K 500V
C27	4010003880	Ceramic	DD06 SL 150K 500V
C28	4010004120	Ceramic	DD07 B 102K 500V
C29	4010000380	Ceramic	DD107 SL 221J 50V
C30	4010000380	Ceramic	DD107 SL 221J 50V
C31	4010000520	Ceramic	DD108 B 472K 50V
C33	4010000380	Ceramic	DD107 SL 221J 50V
C34	4010000240	Ceramic	DD104 SL 390J 50V
C35	4010000170	Ceramic	DD104 SL 200J 50V
C36	4010000330	Ceramic	DD105 SL 101J 50V
C37	4040000250	Barrier Layer	UAT 08X 473M
C38	4010000520	Ceramic	DD108 B 472K 50V
C39	4010000380	Ceramic	DD107 SL 221J 50V
C40	4510003890	Electrolytic	16 MV 10 HW
C41	4010000500	Ceramic	DD104 B 102K 50V
C42	4010000500	Ceramic	DD104 B 102K 50V
C43	4010003790	Ceramic	DD06 SL 020C 500V (IC-970M only)
EP1	0910023833	P.C. Board	B 2227C (144 PA L)
EP2	6910000630	Bead core	FSOH070RN

[144 PA L UNIT]

REF. NO.	ORDER NO.	DESCRIPTION	
D1	1790000070	Diode	1SS237
D2	1790000070	Diode	1SS237
D3	1790000070	Diode	1SS237
D4	1790000070	Diode	1SS237
D6	1710000290	Diode	MI308
D7	1710000290	Diode	MI308
D8	1710000290	Diode	MI308
L1	6110001740	Coil	LA-263
L2	6110001740	Coil	LA-263
L3	6110001740	Coil	LA-263
L4	6110001670	Coil	LA-253
L5	6170000180	Coil	LW-19
L6	6170000070	Coil	LW-9
L7	6170000180	Coil	LW-19
L8	6110001550	Coil	LA-235
L9	6110001550	Coil	LA-235
L10	6910000670	Coil	BT01RN1-A61-001
L11	6910000670	Coil	BT01RN1-A61-001
R1	7080000150	Resistor	RGB3L R15 (IC-970M)
	7080000140	Resistor	RGB2L R33 (IC-970)
R2	7010001150	Resistor	R25XJ 1 kΩ
R3	7010001150	Resistor	R25XJ 1 kΩ
R4	7010003480	Resistor	ELR20J 4.7 kΩ
R5	7010003480	Resistor	ELR20J 4.7 kΩ
R8	7010004770	Resistor	R50XJ 330 Ω
R9	7010004770	Resistor	R50XJ 330 Ω
R10	7010004270	Resistor	R20J 4.7 kΩ
R11	7010004270	Resistor	R20J 4.7 kΩ
R12	7010004270	Resistor	R20J 4.7 kΩ
R13	7010004270	Resistor	R20J 4.7 kΩ
C1	4510003930	Electrolytic	16 MV 470 HW
C2	4010000520	Ceramic	DD108 B 472K 50V
C3	4010000500	Ceramic	DD104 B 102K 50V
C4	4010000520	Ceramic	DD108 B 472K 50V
C5	4010000500	Ceramic	DD104 B 102K 50V
C6	4510003930	Electrolytic	16 MV 470 HW
C7	4010000520	Ceramic	DD108 B 472K 50V
C8	4010000500	Ceramic	DD104 B 102K 50V
C9	4010000380	Ceramic	DD107 SL 221J 50V
C10	4010000500	Ceramic	DD104 B 102K 50V
C11	4010000380	Ceramic	DD107 SL 221J 50V
C12	4010000380	Ceramic	DD107 SL 221J 50V

[430 PA L UNIT]

REF. NO.	ORDER NO.	DESCRIPTION	
D1	1790000070	Diode	1SS237
D2	1790000070	Diode	1SS237
D3	1790000070	Diode	1SS237
D4	1790000070	Diode	1SS237
D6	1710000290	Diode	MI308
D7	1710000290	Diode	MI308
D8	1710000290	Diode	MI308
L1	6110001520	Coil	LA-232
L2	6110001600	Coil	LA-243
L4	6110001520	Coil	LA-232
L5	6110001570	Coil	LA-237
L6	6110001570	Coil	LA-237
L7	6110001520	Coil	LA-232
L8	6110001520	Coil	LA-232
L9	6910000670	Coil	BT01RN1-A61-001
L10	6910000670	Coil	BT01RN1-A61-001
L11	6180000880	Coil	LAL 03NA 100K
L12	6170000180	Coil	LW-19
L13	6180000880	Coil	LAL 03NA 100K
R1	7080000150	Resistor	RGB3L R15 (IC-970M)
	7080000140	Resistor	RGB2L R33 (IC-970)
R2	7010003400	Resistor	ELR20J 1 kΩ
R3	7010003400	Resistor	ELR20J 1 kΩ
R4	7010004270	Resistor	R20J 4.7 kΩ (IC-970M only)
R5	7010003450	Resistor	ELR20J 2.7 kΩ
R6	7010003450	Resistor	ELR20J 2.7 kΩ
R9	7010004770	Resistor	R50XJ 330 Ω
R10	7010004770	Resistor	R50XJ 330 Ω
R11	7010004250	Resistor	R20J 3.3 kΩ
R13	7010004250	Resistor	R20J 3.3 kΩ

[430 PA L UNIT]

REF. NO.	ORDER NO.	DESCRIPTION	
C1	4510003930	Electrolytic	16 MV 470 HW
C2	4010000500	Ceramic	DD104 B 102K 50V
C3	4010000260	Ceramic	DD104 SL 470J 50V
C4	4010000500	Ceramic	DD104 B 102K 50V
C5	4010000260	Ceramic	DD104 SL 470J 50V
C6	4510003930	Electrolytic	16 MV 470 HW
C7	4010000500	Ceramic	DD104 B 102K 50V
C8	4010000260	Ceramic	DD104 SL 470J 50V
C9	4010000500	Ceramic	DD104 B 102K 50V
C10	4010000260	Ceramic	DD104 SL 470J 50V
C11	4010000260	Ceramic	DD104 SL 470J 50V
C12	4010000260	Ceramic	DD104 SL 470J 50V
C13	4010000260	Ceramic	DD104 SL 470J 50V
C14	4010000260	Ceramic	DD104 SL 470J 50V
C15	4010003840	Ceramic	DD08 SL 070D 500V
C20	4010000500	Ceramic	DD104 B 102K 50V
C21	4010000500	Ceramic	DD104 B 102K 50V
C22	4010003840	Ceramic	DD08 SL 070D 500V
C23	4010003850	Ceramic	DD08 SL 080D 500V
C24	4010003880	Ceramic	DD08 SL 150K 500V
C25	4010003870	Ceramic	DD08 SL 120K 500V
C26	4010003880	Ceramic	DD08 SL 150K 500V
C27	4010003790	Ceramic	DD08 SL 020C 500V
C28	4010003780	Ceramic	DD08 SL 010C 500V
C29	4010003850	Ceramic	DD08 SL 080D 500V
C30	4010003810	Ceramic	DD08 SL 040C 500V
C31	4010000260	Ceramic	DD104 SL 470J 50V
C32	4010000500	Ceramic	DD104 B 102K 50V
C36	4010000500	Ceramic	DD104 B 102K 50V
C37	4010000110	Ceramic	DD104 SL 090D 50V
C38	4010000050	Ceramic	DD104 SL 030C 50V
C39	4010000500	Ceramic	DD104 B 102K 50V
C40	4010000520	Ceramic	DD108 B 472K 50V
C41	4010000500	Ceramic	DD104 B 102K 50V
C42	4010000260	Ceramic	DD104 SL 470J 50V
C43	4510003890	Electrolytic	16 MV 10 HW
C44	4010000500	Ceramic	DD104 B 102K 50V
C45	4010000500	Ceramic	DD104 B 102K 50V
C46	4010000500	Ceramic	DD104 B 102K 50V (IC-970 only)
EP1	0910023823	P.C. Board	B 2228C (430 PA L)

[DRIVER UNIT]

REF. NO.	ORDER NO.	DESCRIPTION	
L1	6110001570	Coil	LA-237
L2	6110001520	Coil	LA-232
L3	6110001520	Coil	LA-232
R1	7010004120	Resistor	R20J 270 Ω
R2	7010003980	Resistor	R20J 18 Ω
R3	7010004120	Resistor	R20J 270 Ω
C1	4010000500	Ceramic	DD104 B 102K 50V
C2	4010000500	Ceramic	DD104 B 102K 50V
C3	4010000500	Ceramic	DD104 B 102K 50V
C4	4510003980	Electrolytic	10 MV 100 HWS (5X11)
C5	4510003900	Electrolytic	16 MV 22 HW
C6	4510003900	Electrolytic	16 MV 22 HW
C7	4010003810	Ceramic	DD08 SL 040C 500V
C8	4010003850	Ceramic	DD08 SL 080D 500V
C9	4010003810	Ceramic	DD08 SL 040C 500V
EP1	0910022942	P.C. Board	B 2213B (DRIVER)

[JACK-A UNIT]

REF. NO.	ORDER NO.	DESCRIPTION	
Q1	1530002650	Transistor	2SC1384-R
Q2	1590000340	Transistor	RN1202
D1	1710000160	Diode	1SS133
L1	6910000670	Coil	BT01RN1-A61-001
L2	6910000670	Coil	BT01RN1-A61-001
L3	6910000670	Coil	BT01RN1-A61-001
L4	6910000670	Coil	BT01RN1-A61-001
L5	6910000670	Coil	BT01RN1-A61-001
L6	6910000670	Coil	BT01RN1-A61-001
L7	6910000670	Coil	BT01RN1-A61-001
L8	6910000670	Coil	BT01RN1-A61-001
L9	6910000670	Coil	BT01RN1-A61-001
L10	6910000670	Coil	BT01RN1-A61-001
L11	6910000670	Coil	BT01RN1-A61-001
L12	6910000670	Coil	BT01RN1-A61-001
L13	6910000670	Coil	BT01RN1-A61-001
L14	6910000670	Coil	BT01RN1-A61-001
L15	6910000670	Coil	BT01RN1-A61-001
L16	6910000670	Coil	BT01RN1-A61-001
L17	6910000670	Coil	BT01RN1-A61-001
L18	6910000670	Coil	BT01RN1-A61-001
L19	6910000670	Coil	BT01RN1-A61-001
L20	6180000770	Coil	LAL 03NA 1R0M
L21	6180001380	Coil	LAL 02KR 1R0K
R1	7510000550	Thermistor	ERT-D2ZHL333S (IC-970D)
R2	7010003580	Resistor	ELR20J 22 kΩ
R3	7010003540	Resistor	ELR20J 12 kΩ
C1	4530000030	Capacitor Array	B5RC0124-32N
C2	4530000190	Capacitor Array	B7ZC0716-32N
C3	4010000500	Ceramic	DD104 B 102K 50V
C4	4010000500	Ceramic	DD104 B 102K 50V
C5	4010000500	Ceramic	DD104 B 102K 50V
C6	4010000500	Ceramic	DD104 B 102K 50V
C7	4010000260	Ceramic	DD104 SL 470J 50V
C8	4510003890	Electrolytic	16 MV 10 HW
C9	4010000500	Ceramic	DD104 B 102K 50V
C10	4010000500	Ceramic	DD104 B 102K 50V
C11	4010000500	Ceramic	DD104 B 102K 50V
EP1	0910023904	P.C. Board	B 2279D (JACK-A)

[JACK-B UNIT]

REF. NO.	ORDER NO.	DESCRIPTION	
L1	6910000670	Coil	BT01RN1-A61-001
L2	6910000670	Coil	BT01RN1-A61-001
L3	6910000670	Coil	BT01RN1-A61-001
L4	6180001490	Coil	LAL 02KR 101K
C1	4010000260	Ceramic	DD104 SL 470J 50V
C2	4010000500	Ceramic	DD104 B 102K 50V
C3	4010000500	Ceramic	DD104 B 102K 50V
EP1	0910024363	P.C. Board	B 2285C (JACK-B)

[CONNECT UNIT]

REF. NO.	ORDER NO.	DESCRIPTION
D1	171000010	Diode 15CD11
EP1	0910023932	P.C. Board B 2313B (CONNECT)

[RF-A UNIT]

REF. NO.	ORDER NO.	DESCRIPTION
Q1	1560000100	FET 2SK241-Y
Q2	1560000100	FET 2SK241-Y
Q3	1530001810	Transistor 2SC3355
Q4	1530000810	Transistor 2SC2053
Q5	1530000770	Transistor 2SC1947 (IC-970D only)
Q6	1560000130	FET 2SK125
Q7	1560000130	FET 2SK125
Q8	1580000050	FET 3SK121-Y
Q9	1590000350	Transistor RN1204
Q10	1590000360	Transistor RN2202
Q11	1590000360	Transistor RN2202
Q12	1530000810	Transistor 2SC2053
Q13	1590000350	Transistor RN1204
Q14	1590000360	Transistor RN2202
Q15	1530001810	Transistor 2SC3355
Q16	1590000350	Transistor RN1204
Q17	1590000350	Transistor RN1204
Q18	1590000350	Transistor RN1204
D1	1710000050	Diode 1SS53 (IC-970D only)
D2	1710000040	Diode 1S953
D3	1710000050	Diode 1SS53
D4	1710000050	Diode 1SS53
D5	1710000050	Diode 1SS53
D6	1710000050	Diode 1SS53
D7	1710000160	Diode 1SS133
D8	1710000280	Diode MI301
D9	1710000160	Diode 1SS133
D10	1710000280	Diode MI301
D11	1710000580	Diode 1SS265
D12	1710000580	Diode 1SS265
D13	1710000580	Diode 1SS265
D14	1720000060	Varicap 1SV50(1)E
D15	1720000060	Varicap 1SV50(1)E
D16	1720000060	Varicap 1SV50(1)E
D17	1710000580	Diode 1SS265
D18	1710000280	Diode MI301
D19	1710000040	Diode 1S953
D20	1710000180	Diode 1SS133
D21	1790000240	Diode 1SS99
L1	6150001480	Coil LS-164
L2	6150001310	Coil LS-145
L3	6130000660	Coil LB-83
L4	6130000020	Coil LB-1-1A
L5	6130000340	Coil LB-50A
L6	6110001660	Coil LA-252
L7	6130000660	Coil LB-83
L8	6130000340	Coil LB-50A
L9	6110001750	Coil LA-264
L10	6180000770	Coil LAL 03NA 1R0M (IC-970D only)
L11	6110001520	Coil LA-232 (IC-970D only)
L12	6110001650	Coil LA-248 (IC-970D only)
L13	6110001670	Coil LA-253
L14	6150002200	Coil LS-228
L15	6140001200	Coil LR-145
L16	6110001550	Coil LA-235
L17	6130000340	Coil LB-50A

[RF-A UNIT]

REF. NO.	ORDER NO.	DESCRIPTION
L18	6130000020	Coil LB-1-1A
L19	6130000170	Coil LB-34A
L20	6130000170	Coil LB-34A
L21	6130000340	Coil LB-50A
L22	6140000930	Coil LR-116
L23	6110001540	Coil LA-234
L24	6110001540	Coil LA-234
L25	6150002880	Coil LS-302
L26	6150002880	Coil LS-302
L27	6150002880	Coil LS-302
L28	6110001620	Coil LA-245
L29	6110001610	Coil LA-244
L30	6110001620	Coil LA-245
L31	6110001530	Coil LA-233
L32	6110001550	Coil LA-235
R1	7010003440	Resistor ELR20J 2.2 kΩ
R2	7310003170	Trimmer EVN-2ACA00 B53 (502) (IC-970/970D)
	7310003180	Trimmer EVN-2ACA00 B24 (203) (IC-970M)
R3	7310003160	Trimmer EVN-2ACA00 B13 (102)
R4	7010004070	Resistor R20J 100 Ω
R5	7010000990	Resistor R25XJ 47 Ω
R6	7010003400	Resistor ELR20J 1 kΩ
R7	7010003470	Resistor ELR20J 3.9 kΩ
R8	7010004690	Resistor R50XJ 47 Ω
R9	7010003420	Resistor ELR20J 1.5 kΩ
R11	7010003880	Resistor R20J 2.7 Ω (IC-970D only)
R12	7010003090	Resistor ELR20J 2.7 Ω (IC-970D only)
R13	7010003360	Resistor ELR20J 470 Ω (IC-970D only)
R14	7010003360	Resistor ELR20J 470 Ω (IC-970D only)
R15	7010003930	Resistor R20J 6.8 Ω (IC-970D only)
R16	7010004030	Resistor R20J 47 Ω (IC-970D only)
R17	7010004650	Resistor R50XJ 10 Ω (IC-970D only)
R18	7010004230	Resistor R20J 2.2 kΩ
R19	7010004230	Resistor R20J 2.2 kΩ
R20	7010003440	Resistor ELR20J 2.2 kΩ
R21	7010004030	Resistor R20J 47 Ω
R22	7310003180	Trimmer EVN-2ACA00 B24 (203)
R23	7010003360	Resistor ELR20J 470 Ω
R24	7010003360	Resistor ELR20J 470 Ω
R25	7010004190	Resistor R20J 1 kΩ
R26	7010003300	Resistor ELR20J 150 Ω
R27	7010004260	Resistor R20J 3.9 kΩ
R28	7010004330	Resistor R20J 12 kΩ
R29	7010004030	Resistor R20J 47 Ω
R30	7010004030	Resistor R20J 47 Ω
R31	7010003280	Resistor ELR20J 100 Ω
R32	7010004450	Resistor R20J 100 kΩ
R34	7010003600	Resistor ELR20J 33 kΩ
R35	7010004330	Resistor R20J 12 kΩ
R36	7010003470	Resistor ELR20J 3.9 kΩ
R37	7010004070	Resistor R20J 100 Ω
R38	7010003530	Resistor ELR20J 10 kΩ
R39	7010003400	Resistor ELR20J 1 kΩ
R40	7010000790	Resistor R25XJ 1 Ω
R41	7010003300	Resistor ELR20J 150 Ω
R43	7010004170	Resistor R20J 680 Ω
R44	7010004200	Resistor R20J 1.2 kΩ
R45	7010004410	Resistor R20J 47 kΩ
R46	7010004030	Resistor R20J 47 Ω
R47	7010004450	Resistor R20J 100 kΩ
R48	7010004450	Resistor R20J 100 kΩ
R49	7010004450	Resistor R20J 100 kΩ
R50	7010004050	Resistor R20J 68 Ω
R51	7010004170	Resistor R20J 680 Ω
R52	7010003290	Resistor ELR20J 120 Ω
R53	7010004030	Resistor R20J 47 Ω
R56	7010003360	Resistor ELR20J 470 Ω
R57	7010004250	Resistor R20J 3.3 kΩ

[RF-A UNIT]

REF. NO.	ORDER NO.	DESCRIPTION	
R58	7010003470	Resistor	ELR20J 3.9 kΩ
R59	7010003530	Resistor	ELR20J 10 kΩ
R60	7010004220	Resistor	R20J 1.8 kΩ
R61	7010003310	Resistor	ELR20J 180 Ω
R62	7010003280	Resistor	ELR20J 100 Ω
R63	7010003600	Resistor	ELR20J 33 kΩ
R64	7010003240	Resistor	ELR20J 47 Ω
R65	7010003320	Resistor	ELR20J 220 Ω
R66	7010003180	Resistor	ELR20J 10 Ω
R67	7010001190	Resistor	R25XJ 2.2 kΩ
R68	7010004190	Resistor	R20J 1 kΩ
R69	7010003470	Resistor	ELR20J 3.9 kΩ
R70	7010004010	Resistor	R20J 33 Ω
C2	4010000520	Ceramic	DD108 B 472K 50V
C3	4010000330	Ceramic	DD105 SL 101J 50V
C4	4010000220	Ceramic	DD104 SL 330J 50V
C5	4010000220	Ceramic	DD104 SL 330J 50V
C6	4010000500	Ceramic	DD104 B 102K 50V
C7	4010000500	Ceramic	DD104 B 102K 50V
C8	4610000770	Trimmer	CV38D 1001
C9	4010000760	Ceramic	DD104 CH 180J 50V
C10	4010000500	Ceramic	DD104 B 102K 50V
C11	4010000380	Ceramic	DD107 SL 221J 50V
C12	4010000500	Ceramic	DD104 B 102K 50V
C13	4010000200	Ceramic	DD104 SL 270J 50V
C14	4010000380	Ceramic	DD107 SL 221J 50V
C15	4010000500	Ceramic	DD104 B 102K 50V
C16	4610000780	Trimmer	CV38D 2001
C17	4010000520	Ceramic	DD108 B 472K 50V
C18	4010000150	Ceramic	DD104 SL 150J 50V
C19	4040000150	Barrier Layer	UAT 05X 472K
C20	4040000150	Barrier Layer	UAT 05X 472K
C21	4040000150	Barrier Layer	UAT 05X 472K
C22	4010000340	Ceramic	DD105 SL 121J 50V
C23	4010000500	Ceramic	DD104 B 102K 50V
C24	4010000500	Ceramic	DD104 B 102K 50V
C25	4010000500	Ceramic	DD104 B 102K 50V
C26	4010000340	Ceramic	DD105 SL 121J 50V
C27	4010000500	Ceramic	DD104 B 102K 50V (IC-970D only)
C28	4010000500	Ceramic	DD104 B 102K 50V
C29	4010000180	Ceramic	DD104 SL 220J 50V
C30	4010000500	Ceramic	DD104 B 102K 50V
C31	4010000500	Ceramic	DD104 B 102K 50V
C32	4010000500	Ceramic	DD104 B 102K 50V
C33	4010000500	Ceramic	DD104 B 102K 50V
C34	4010000500	Ceramic	DD104 B 102K 50V
C35	4010000500	Ceramic	DD104 B 102K 50V
C36	4010003290	Ceramic	DD104 UJ 050C 50V
C37	4010000190	Ceramic	DD104 SL 240J 50V
C38	4010000500	Ceramic	DD104 B 102K 50V
C39	4010000380	Ceramic	DD107 SL 221J 50V
C40	4010000500	Ceramic	DD104 B 102K 50V
C41	4010000500	Ceramic	DD104 B 102K 50V (IC-970D only)
C42	4010000500	Ceramic	DD104 B 102K 50V (IC-970D only)
C43	4610000800	Trimmer	CV38B 0801 (IC-970D only)
C44	4010000220	Ceramic	DD104 SL 330J 50V (IC-970D only)
C45	4610000790	Trimmer	CV38E 3001 (IC-970D only)
C46	4010000180	Ceramic	DD104 SL 220J 50V (IC-970D only)
C47	4010000150	Ceramic	DD104 SL 150J 50V (IC-970D only)
C48	4010000500	Ceramic	DD104 B 102K 50V (IC-970D only)
C49	4040000280	Barrier Layer	UZE 08X 104M (IC-970D only)
C50	4510003910	Electrolytic	18 MV 47 HW (IC-970D only)
C51	4010000500	Ceramic	DD104 B 102K 50V (IC-970D only)
C53	4010000330	Ceramic	DD105 SL 101J 50V
C54	4010000500	Ceramic	DD104 B 102K 50V

[RF-A UNIT]

REF. NO.	ORDER NO.	DESCRIPTION	
C55	4010000500	Ceramic	DD104 B 102K 50V
C56	4010000500	Ceramic	DD104 B 102K 50V
C57	4010000500	Ceramic	DD104 B 102K 50V
C58	4010000170	Ceramic	DD104 SL 200J 50V
C59	4010000120	Ceramic	DD104 SL 100D 50V
C60	4010000100	Ceramic	DD104 SL 080D 50V
C61	4010000180	Ceramic	DD104 SL 220J 50V
C62	4010000520	Ceramic	DD108 B 472K 50V
C63	4010000180	Ceramic	DD104 SL 180J 50V
C64	4010000020	Ceramic	DD104 SL 010C 50V
C65	4010000010	Ceramic	DD104 SL 0R5C 50V
C66	4010000160	Ceramic	DD104 SL 180J 50V
C68	4010000010	Ceramic	DD104 SL 0R5C 50V
C69	4010000160	Ceramic	DD104 SL 180J 50V
C70	4010000500	Ceramic	DD104 B 102K 50V
C71	4010000020	Ceramic	DD104 SL 010C 50V
C72	4010000500	Ceramic	DD104 B 102K 50V
C73	4010000500	Ceramic	DD104 B 102K 50V
C74	4010000380	Ceramic	DD107 SL 221J 50V
C75	4010000500	Ceramic	DD104 B 102K 50V
C76	4020000770	Cylinder	UP050 SL 200J
C77	4010000220	Ceramic	DD104 SL 330J 50V
C78	4020000620	Cylinder	UP050 SL 220J
C79	4010000160	Ceramic	DD104 SL 180J 50V
C80	4010000190	Ceramic	DD104 SL 240J 50V
C81	4010000500	Ceramic	DD104 B 102K 50V
C82	4010000180	Ceramic	DD104 SL 220J 50V
C83	4010000650	Ceramic	DD104 CH 050C 50V
C84	4010000500	Ceramic	DD104 B 102K 50V
C85	4010000500	Ceramic	DD104 B 102K 50V
C86	4010000500	Ceramic	DD104 B 102K 50V
C87	4010000500	Ceramic	DD104 B 102K 50V
C88	4010000500	Ceramic	DD104 B 102K 50V
C89	4010000500	Ceramic	DD104 B 102K 50V
C91	4010000500	Ceramic	DD104 B 102K 50V
C92	4010000500	Ceramic	DD104 B 102K 50V
C93	4010000500	Ceramic	DD104 B 102K 50V
C94	4010000500	Ceramic	DD104 B 102K 50V
C95	4010000500	Ceramic	DD104 B 102K 50V
C96	4010000500	Ceramic	DD104 B 102K 50V
C97	4010000500	Ceramic	DD104 B 102K 50V
C98	4010000500	Ceramic	DD104 B 102K 50V
C99	4010000500	Ceramic	DD104 B 102K 50V
C100	4510003910	Electrolytic	18 MV 47 HW
C101	4010000180	Ceramic	DD104 SL 220J 50V
C102	4010000070	Ceramic	DD104 SL 050C 50V
C103	4010000070	Ceramic	DD104 SL 050C 50V
C104	4010000070	Ceramic	DD104 SL 050C 50V
C105	4010000070	Ceramic	DD104 SL 050C 50V
C106	4010000070	Ceramic	DD104 SL 050C 50V
C107	4010000500	Ceramic	DD104 B 102K 50V
C108	4010003290	Ceramic	DD104 UJ 050C 50V
C109	4040000150	Barrier Layer	UAT 05X 472K
EP1	0910023565	P.C. Board	B 2250E (RF-A)

[RF-B UNIT]

REF. NO.	ORDER NO.	DESCRIPTION	
IC1	1790000050	IC	ND487C1-3R
IC2	6910000200	IC	DM 412E H
IC3	1790000050	IC	ND487C1-3R
Q1	1530000250	Transistor	2SC763 C
Q2	1530001810	Transistor	2SC3355
Q3	1530001810	Transistor	2SC3355
Q4	1530000640	Transistor	2SC2407(A) (IC-970/970D)
	1530000900	Transistor	2SC3019 (IC-970M)
Q5	1530000150	Transistor	2SC2668-O
Q6	1530001810	Transistor	2SC3355
Q7	1580000110	FET	3SK74 M
Q8	1580000110	FET	3SK74 M
Q9	1530000520	Transistor	2SC2026
Q10	1530000520	Transistor	2SC2026
Q11	1530002210	Transistor	2SC3776-D
Q12	1580000050	FET	3SK121-Y
Q13	1590000350	Transistor	RN1204
Q14	1590000350	Transistor	RN1204
Q15	1590000350	Transistor	RN1204
D1	1710000050	Diode	1SS53
D2	1710000410	Diode	MI105
D3	1710000410	Diode	MI105
D4	1710000030	Diode	1S1555 (IC-970/970D)
D5	1710000410	Diode	MI105
D6	1710000050	Diode	1SS53
D7	1710000050	Diode	1SS53
D8	1710000160	Diode	1SS133
D9	1710000160	Diode	1SS133
D10	1710000050	Diode	1SS53
D11	1710000050	Diode	1SS53
D12	1710000580	Diode	1SS265
D13	1710000580	Diode	1SS265
D14	1710000580	Diode	1SS265
D15	1710000410	Diode	MI105
D16	1710000580	Diode	1SS265
D17	1710000280	Diode	MI301
D18	1710000030	Diode	1S1555
D19	1710000050	Diode	1SS53
F11	2010001110	Filter	71M15A1 (FL-131)
F12	2010001100	Filter	71M15A (FL-130)
L1	6150002990	Coil	LS-310
L2	6150002890	Coil	LS-303
L3	6140000930	Coil	LR-116
L4	6150002550	Coil	LS-284
L5	6150002550	Coil	LS-284
L6	6150000990	Coil	LS-114
L7	6150002550	Coil	LS-284
L8	6190000050	Coil	7HW-252MX-1550A
L9	6180000770	Coil	LAL 03NA 1R0M
L10	6180000770	Coil	LAL 03NA 1R0M
L12	6190000050	Coil	7HW-252MX-1550A
L13	6180000770	Coil	LAL 03NA 1R0M
L14	6110001990	Coil	LA-223 (IC-970/D)
	6110001980	Coil	LA-222 (IC-970M)
L15	6180000770	Coil	LAL 03NA 1R0M
L16	6110001980	Coil	LA-222
L19	6110001980	Coil	LA-222
L20	6150002990	Coil	LS-310
L21	6150002890	Coil	LS-303
L22	6140001800	Coil	LR-178
L23	6180001380	Coil	LAL 02KR 1R0K
L24	6150002550	Coil	LS-284
L25	6150002550	Coil	LS-284
L26	6180000770	Coil	LAL 03NA 1R0M
L27	6180001380	Coil	LAL 02KR 1R0K
L28	6110001810	Coil	LA-244
L29	6110001530	Coil	LA-233

[RF-B UNIT]

REF. NO.	ORDER NO.	DESCRIPTION	
L30	6110001530	Coil	LA-233
L31	6150000990	Coil	LS-114
L32	6150002430	Coil	LS-254
L33	6150002430	Coil	LS-254
L34	6150000990	Coil	LS-114
L35	6150002430	Coil	LS-254
L36	6150002430	Coil	LS-254
L37	6150001310	Coil	LS-145
L38	6140001200	Coil	LR-145
L39	6180000770	Coil	LAL 03NA 1R0M
L40	6190000050	Coil	7HW-252MX-1550A
L41	6190000050	Coil	7HW-252MX-1550A
L42	6170000180	Coil	LW-19
L43	6110001830	Coil	LA-159
L44	6180001380	Coil	LAL 02KR 1R0K
L46	6180002400	Coil	LAL 02NA 1R0K
L47	6150002550	Coil	LS-284
R1	7010003440	Resistor	ELR20J 2.2 kΩ
R2	7010004120	Resistor	R20J 270 Ω
R4	7010003530	Resistor	ELR20J 10 kΩ
R5	7010004370	Resistor	R20J 22 kΩ
R6	7010003160	Resistor	ELR20J 10 Ω
R7	7010004070	Resistor	R20J 100 Ω
R8	7010003330	Resistor	ELR20J 270 Ω
R9	7010003190	Resistor	ELR20J 18 Ω
R10	7010003330	Resistor	ELR20J 270 Ω
R11	7010003390	Resistor	ELR20J 820 Ω
R12	7010003130	Resistor	ELR20J 5.6 Ω
R13	7010003390	Resistor	ELR20J 820 Ω
R14	7010003270	Resistor	ELR20J 82 Ω
R15	7010004130	Resistor	R20J 330 Ω
R16	7010003400	Resistor	ELR20J 1 kΩ
R17	7010003510	Resistor	ELR20J 6.8 kΩ
R18	7010004070	Resistor	R20J 100 Ω
R19	7010003320	Resistor	ELR20J 220 Ω
R20	7010003400	Resistor	ELR20J 1 kΩ
R21	7010003490	Resistor	ELR20J 5.6 kΩ
R22	7010004030	Resistor	R20J 47 Ω
R23	7010000140	Resistor	ELR25J 12 Ω (IC-970/970D)
	7010000170	Resistor	ELR25J 22 Ω (IC-970M)
R24	7010004260	Resistor	R20J 3.9 kΩ (IC-970/970D)
	7010004250	Resistor	R20J 3.3 kΩ (IC-970M)
R25	7010003400	Resistor	ELR20J 1 kΩ (IC-970/970D)
	7010003340	Resistor	ELR20J 330 Ω (IC-970M)
R26	7010004230	Resistor	R20J 2.2 kΩ
R27	7010003330	Resistor	ELR20J 270 Ω
R28	7010003440	Resistor	ELR20J 2.2 kΩ
R29	7010003440	Resistor	ELR20J 2.2 kΩ
R30	7010003330	Resistor	ELR20J 270 Ω
R31	7010003340	Resistor	ELR20J 330 Ω
R32	7010003440	Resistor	ELR20J 2.2 kΩ
R34	7010004070	Resistor	R20J 100 Ω
R35	7010003460	Resistor	ELR20J 3.3 kΩ
R36	7010004370	Resistor	R20J 22 kΩ
R37	7010004070	Resistor	R20J 100 Ω
R38	7010004120	Resistor	R20J 270 Ω
R39	7010004070	Resistor	R20J 100 Ω
R40	7010003400	Resistor	ELR20J 1 kΩ
R41	7010003480	Resistor	ELR20J 4.7 kΩ
R42	7010004070	Resistor	R20J 100 Ω
R43	7310003240	Trimmer	EVN-2ACA00 B23 (202)
R44	7010003240	Resistor	ELR20J 47 Ω
R45	7510000300	Thermistor	ERT-D2ZGL601S
R47	7010003200	Resistor	ELR20J 22 Ω
R48	7010004230	Resistor	R20J 2.2 kΩ
R49	7310003240	Trimmer	EVN-2ACA00 B23 (202)
R50	7010003240	Resistor	ELR20J 47 Ω
R51	7510000300	Thermistor	ERT-D2ZGL601S
R53	7010003200	Resistor	ELR20J 22 Ω

[RF-B UNIT]

REF. NO.	ORDER NO.	DESCRIPTION	
R54	7010004230	Resistor	R20J 2.2 kΩ
R55	7010003440	Resistor	ELR20J 2.2 kΩ
R56	7010004090	Resistor	R20J 150 Ω
R57	7010004070	Resistor	R20J 100 Ω
R58	7010004160	Resistor	R20J 560 Ω
R59	7010003160	Resistor	ELR20J 10 Ω
R60	7010003950	Resistor	R20J 10 Ω
R61	7010003580	Resistor	ELR20J 22 kΩ
R62	7010004130	Resistor	R20J 330 Ω
R63	7010004190	Resistor	R20J 1 kΩ
R64	7010003280	Resistor	ELR20J 100 Ω
R65	7010003220	Resistor	ELR20J 33 Ω
R66	7010003310	Resistor	ELR20J 180 Ω
R67	7010003340	Resistor	ELR20J 330 Ω
R68	7010004070	Resistor	R20J 100 Ω
R69	7010003460	Resistor	ELR20J 3.3 kΩ
R70	7010004070	Resistor	R20J 100 Ω
R71	7010003270	Resistor	ELR20J 82 Ω
R72	7010003600	Resistor	ELR20J 33 kΩ
R73	7010004450	Resistor	R20J 100 kΩ
R74	7010003480	Resistor	ELR20J 4.7 kΩ
R75	7010004350	Resistor	R20J 18 kΩ
R76	7010003510	Resistor	ELR20J 6.8 kΩ
R78	7010003440	Resistor	ELR20J 2.2 kΩ
R79	7010003440	Resistor	ELR20J 2.2 kΩ
R80	7010004150	Resistor	R20J 470 Ω
R81	7010003240	Resistor	ELR20J 47 Ω
R82	7310003170	Trimmer	EVN-2ACA00 B53 (502)
R83	7010003240	Resistor	ELR20J 47 Ω
R84	7010003290	Resistor	ELR20J 120 Ω
R85	7010003460	Resistor	ELR20J 3.3 kΩ
R86	7010003160	Resistor	ELR20J 10 Ω
R87	7010003970	Resistor	R20J 15 Ω
R89	7010003400	Resistor	ELR20J 1 kΩ (IC-970M only)
R90	7010003300	Resistor	ELR20J 150 Ω
R91	7510000290	Thermistor	ERT-D2ZGL301S
R92	7010003370	Resistor	ELR20J 560 Ω (IC-970M only)
R93	7010003370	Resistor	ELR20J 560 Ω
R94	7010003670	Resistor	ELR20J 120 kΩ
R95	7010003660	Resistor	ELR20J 100 kΩ
R96	7010003370	Resistor	ELR20J 560 Ω
R97	7010003670	Resistor	ELR20J 120 kΩ
R98	7010003660	Resistor	ELR20J 100 kΩ
C1	4010000500	Ceramic	DD104 B 102K 50V
C2	4040000150	Barrier Layer	UAT 05X 472K
C3	4010000040	Ceramic	DD104 SL 020C 50V
C4	4010000500	Ceramic	DD104 B 102K 50V
C5	4040000150	Barrier Layer	UAT 05X 472K
C6	4010000500	Ceramic	DD104 B 102K 50V
C7	4010003290	Ceramic	DD104 UJ 050C 50V
C8	4010000010	Ceramic	DD104 SL 0R5C 50V
C9	4010003290	Ceramic	DD104 UJ 050C 50V
C10	4010000100	Ceramic	DD104 SL 080D 50V
C11	4040000150	Barrier Layer	UAT 05X 472K
C12	4010000020	Ceramic	DD104 SL 010C 50V
C13	4040000480	Barrier Layer	RAU 04AK R75C
C14	4010000070	Ceramic	DD104 SL 050C 50V
C15	4010000500	Ceramic	DD104 B 102K 50V
C16	4010000520	Ceramic	DD108 B 472K 50V
C17	4010000500	Ceramic	DD104 B 102K 50V
C18	4010000260	Ceramic	DD104 SL 470J 50V
C19	4010000220	Ceramic	DD104 SL 330J 50V
C20	4010000500	Ceramic	DD104 B 102K 50V
C22	4010000260	Ceramic	DD104 SL 470J 50V
C23	4010000500	Ceramic	DD104 B 102K 50V
C24	4010000260	Ceramic	DD104 SL 470J 50V
C25	4610000800	Trimmer	CV38B 0601
C26	4010000020	Ceramic	DD104 SL 010C 50V (IC-970/D)
	4010000260	Ceramic	DD104 SL 470J 50V (IC-970M)
C27	4010000260	Ceramic	DD104 SL 470J 50V
C28	4010000260	Ceramic	DD104 SL 470J 50V
C29	4010000500	Ceramic	DD104 B 102K 50V

[RF-B UNIT]

REF. NO.	ORDER NO.	DESCRIPTION	
C30	4010000260	Ceramic	DD104 SL 470J 50V
C31	4010000500	Ceramic	DD104 B 102K 50V
C32	4010000260	Ceramic	DD104 SL 470J 50V
C33	4010000500	Ceramic	DD104 B 102K 50V
C34	4610000800	Trimmer	CV38B 0601
C35	4040000150	Barrier Layer	UAT 05X 472K
C37	4010000040	Ceramic	DD104 SL 020C 50V
C38	4010000500	Ceramic	DD104 B 102K 50V
C39	4010000500	Ceramic	DD104 B 102K 50V
C41	4040000150	Barrier Layer	UAT 05X 472K
C42	4010000500	Ceramic	DD104 B 102K 50V
C43	4010000100	Ceramic	DD104 SL 080D 50V
C44	4020000010	Cylinder	UP125 SL 010M
C45	4010000100	Ceramic	DD104 SL 080D 50V
C46	4010000500	Ceramic	DD104 B 102K 50V
C47	4010000520	Ceramic	DD108 B 472K 50V
C49	4010000180	Ceramic	DD104 SL 220J 50V
C50	4010000500	Ceramic	DD104 B 102K 50V
C51	4010000180	Ceramic	DD104 SL 220J 50V
C52	4610000770	Trimmer	CV38D 1001
C53	4010000500	Ceramic	DD104 B 102K 50V
C54	4010000500	Ceramic	DD104 B 102K 50V
C55	4010000460	Ceramic	DD104 B 471K 50V
C56	4610000780	Trimmer	CV38D 2001
C57	4010000140	Ceramic	DD104 SL 120J 50V
C58	4010000520	Ceramic	DD108 B 472K 50V
C59	4010000500	Ceramic	DD104 B 102K 50V
C60	4010000050	Ceramic	DD104 SL 030C 50V
C61	4010000520	Ceramic	DD108 B 472K 50V
C62	4010000520	Ceramic	DD108 B 472K 50V
C65	4010000060	Ceramic	DD104 SL 040C 50V
C66	4010000520	Ceramic	DD108 B 472K 50V
C68	4010000520	Ceramic	DD108 B 472K 50V
C69	4010000500	Ceramic	DD104 B 102K 50V
C70	4010000050	Ceramic	DD104 SL 030C 50V
C71	4010000520	Ceramic	DD108 B 472K 50V
C72	4010000520	Ceramic	DD108 B 472K 50V
C74	4010000060	Ceramic	DD104 SL 040C 50V
C75	4010000520	Ceramic	DD108 B 472K 50V
C76	4010000280	Ceramic	DD104 SL 560J 50V
C77	4010000260	Ceramic	DD104 SL 470J 50V
C78	4010000500	Ceramic	DD104 B 102K 50V
C79	4010000500	Ceramic	DD104 B 102K 50V
C80	4010000500	Ceramic	DD104 B 102K 50V
C81	4010000330	Ceramic	DD105 SL 101J 50V
C82	4010000260	Ceramic	DD104 SL 470J 50V
C83	4010000500	Ceramic	DD104 B 102K 50V
C85	4010000460	Ceramic	DD104 B 471K 50V
C86	4010000260	Ceramic	DD104 SL 470J 50V
C87	4010000500	Ceramic	DD104 B 102K 50V
C88	4010000460	Ceramic	DD104 B 471K 50V
C89	4020000900	Cylinder	UP050 SL 270J
C90	4010000180	Ceramic	DD104 SL 220J 50V
C91	4010000260	Ceramic	DD104 SL 470J 50V
C92	4010000500	Ceramic	DD104 B 102K 50V
C93	4010000260	Ceramic	DD104 SL 470J 50V
C94	4010000500	Ceramic	DD104 B 102K 50V
C95	4010000500	Ceramic	DD104 B 102K 50V
C96	4010000050	Ceramic	DD104 SL 030C 50V
C97	4610000800	Trimmer	CV38B 0601
C98	4010000140	Ceramic	DD104 SL 120J 50V
C99	4010000260	Ceramic	DD104 SL 470J 50V
C100	4010000500	Ceramic	DD104 B 102K 50V
C101	4010000500	Ceramic	DD104 B 102K 50V
C102	4010000500	Ceramic	DD104 B 102K 50V
C103	4010000500	Ceramic	DD104 B 102K 50V
C104	4010000500	Ceramic	DD104 B 102K 50V
C105	4010000500	Ceramic	DD104 B 102K 50V
C106	4010000500	Ceramic	DD104 B 102K 50V
C107	4010000500	Ceramic	DD104 B 102K 50V
C108	4010000500	Ceramic	DD104 B 102K 50V
C109	4010000500	Ceramic	DD104 B 102K 50V
C110	4510003910	Electrolytic	16 MV 47 HW
C111	4010000080	Ceramic	DD104 SL 060D 50V
C112	4010000080	Ceramic	DD104 SL 060D 50V
C114	4010000500	Ceramic	DD104 B 102K 50V
C118	4010003270	Ceramic	DD104 UJ 030C 50V
C119	4010000220	Ceramic	DD104 SL 330J 50V

[RF-B UNIT]

REF. NO.	ORDER NO.	DESCRIPTION
C120	4010000500	Ceramic DD104 B 102K 50V
C121	4010000500	Ceramic DD104 B 102K 50V
C122	4010000500	Ceramic DD104 B 102K 50V
C123	4010000500	Ceramic DD104 B 102K 50V
C124	4010000050	Ceramic DD104 SL 030C 50V (IC-970/D)
	4010000090	Ceramic DD104 SL 070D 50V (IC-970M)
C125	4010000150	Ceramic DD104 SL 150J 50V
C126	4010000030	Ceramic DD104 SL 1R5C 50V
C127	4010000030	Ceramic DD104 SL 1R5C 50V
C128	4010000070	Ceramic DD104 SL 050C 50V
C129	4010000070	Ceramic DD104 SL 050C 50V
C130	4010000260	Ceramic DD104 SL 470J 50V
C131	4010000260	Ceramic DD104 SL 470J 50V
C132	4010000170	Ceramic DD104 SL 200J 50V
C133	4010000500	Ceramic DD104 B 102K 50V
C135	4010000260	Ceramic DD104 SL 470J 50V
C136	4010000260	Ceramic DD104 SL 470J 50V
C137	4010000500	Ceramic DD104 B 102K 50V
C138	4010000100	Ceramic DD104 SL 080D 50V
C139	4010000070	Ceramic DD104 SL 050C 50V
C140	4010000500	Ceramic DD104 B 102K 50V
C141	4010000160	Ceramic DD104 SL 180J 50V
C142	4010000260	Ceramic DD104 SL 470J 50V
C143	4010000500	Ceramic DD104 B 102K 50V
C144	4010000080	Ceramic DD104 SL 080D 50V
EP1	0910023857	P.C. Board B 2251G (RF-B)
EP2	6910000970	Lead Frame DL 2OP 2.6-3-1.2H

[LOGIC UNIT]

REF. NO.	ORDER NO.	DESCRIPTION
IC1	1140001220	IC HD64180R1P6
IC2	1130003771	IC HM6264ALP15SL
IC3	1130005930	IC SC-1194
IC4	1130002640	IC μ PD71055C
IC5	1140000940	IC TMP82C255AN-2-Z
IC6	1130003860	IC MB4052M-G
IC7	1130004460	IC TC74HC42AP
IC8	1140000940	IC TMP82C255AN-2-Z
IC9	1130003890	IC GD4024B
IC10	1130001050	IC μ PD4094BC
IC11	1130004690	IC LC7366N (DIP)
IC12	1130004680	IC LC7385 (DIP)
IC13	1130003480	IC M50784SP
IC14	1130003480	IC M50784SP
IC15	1130003480	IC M50784SP
IC16	1130003480	IC M50784SP
IC17	1130003890	IC GD4024B
IC18	1130000950	IC S7116A
IC19	1130001050	IC μ PD4094BC
IC20	1110001680	IC S-8054ALB
IC21	1130004630	IC GD4030B
IC22	1130004630	IC GD4030B
IC23	1130003870	IC GD4001B
IC24	1130003880	IC GD4011B
IC25	1130003870	IC GD4001B
IC26	1130003870	IC GD4001B
IC27	1130003870	IC GD4001B
IC29	1130004750	IC MC74HC00AN
IC30	1130004650	IC GD74HC32
IC31	1130004600	IC GD74HC00
IC32	1110002070	IC TA78L08S
IC33	1110002020	IC TA7805S
IC34	1130004620	IC GD4013B
Q1	1530000110	Transistor 2SC2458-GR
Q2	1510000070	Transistor 2SA1048-Y
Q3	1510000070	Transistor 2SA1048-Y
Q4	1530000110	Transistor 2SC2458-GR
Q5	1530000110	Transistor 2SC2458-GR
Q6	1530000110	Transistor 2SC2458-GR
Q7	1530000110	Transistor 2SC2458-GR
Q8	1530000110	Transistor 2SC2458-GR
Q9	1530000110	Transistor 2SC2458-GR
Q11	1530000110	Transistor 2SC2458-GR
Q12	1530002590	Transistor 2SC3422-Y
Q13	1530000110	Transistor 2SC2458-GR
Q14	1530002590	Transistor 2SC3422-Y
Q15	1590000350	Transistor RN1204
Q16	1510000070	Transistor 2SA1048-Y
Q17	1510000070	Transistor 2SA1048-Y
Q18	1590000350	Transistor RN1204
Q19	1590000350	Transistor RN1204
Q20	1590000350	Transistor RN1204
Q21	1590000350	Transistor RN1204
Q22	1590000350	Transistor RN1204
Q23	1590000350	Transistor RN1204
Q24	1590000350	Transistor RN1204
Q25	1590000350	Transistor RN1204
Q26	1590000350	Transistor RN1204
Q27	1530000110	Transistor 2SC2458-GR
D1	1710000050	Diode 1SS53
D2	1710000050	Diode 1SS53
D3	1710000160	Diode 1SS133
D4	1710000160	Diode 1SS133
D5	1710000040	Diode 1S953
D6	1710000160	Diode 1SS133
D7	1790000240	Diode 1SS99
D8	1710000350	Diode 1N4002
D9	1710000350	Diode 1N4002
D10	1710000160	Diode 1SS133
D11	1710000160	Diode 1SS133
D12	1710000160	Diode 1SS133
D13	1710000160	Diode 1SS133
D14	1710000160	Diode 1SS133
D15	1710000160	Diode 1SS133

[LOGIC UNIT]

REF. NO.	ORDER NO.	DESCRIPTION	
D17	1730000050	Zener	RD3.0E B2
D18	1710000180	Diode	1SS133
D19	1710000180	Diode	1SS133
D20	1710000180	Diode	1SS133
D22	1710000180	Diode	1SS133
D24	1710000180	Diode	1SS133
D25	1710000180	Diode	1SS133
D26	1710000180	Diode	1SS133
D27	1710000180	Diode	1SS133
D28	1710000180	Diode	1SS133
D29	1710000180	Diode	1SS133
D30	1710000180	Diode	1SS133
X1	6050003120	Crystal	RF-4A3 FAA NKD (3.579545M)
X2	6050003350	Crystal	RF-4A3 FAF NKD (9.270800M)
R4	7010003400	Resistor	ELR20J 1 kΩ
R5	7010003400	Resistor	ELR20J 1 kΩ
R6	7010003400	Resistor	ELR20J 1 kΩ
R7	7010003400	Resistor	ELR20J 1 kΩ
R8	7010003400	Resistor	ELR20J 1 kΩ
R9	7010003400	Resistor	ELR20J 1 kΩ
R10	7010003400	Resistor	ELR20J 1 kΩ
R11	7010003400	Resistor	ELR20J 1 kΩ
R12	7010003400	Resistor	ELR20J 1 kΩ
R13	7010003400	Resistor	ELR20J 1 kΩ
R14	7010003400	Resistor	ELR20J 1 kΩ
R15	7010003400	Resistor	ELR20J 1 kΩ
R16	7010003400	Resistor	ELR20J 1 kΩ
R17	7010003400	Resistor	ELR20J 1 kΩ
R18	7010003400	Resistor	ELR20J 1 kΩ
R19	7010003400	Resistor	ELR20J 1 kΩ
R20	7010003400	Resistor	ELR20J 1 kΩ
R21	7010003400	Resistor	ELR20J 1 kΩ
R22	7010003400	Resistor	ELR20J 1 kΩ
R23	7010003400	Resistor	ELR20J 1 kΩ
R24	7010003400	Resistor	ELR20J 1 kΩ
R25	7010003400	Resistor	ELR20J 1 kΩ
R26	7010003400	Resistor	ELR20J 1 kΩ
R27	7010003400	Resistor	ELR20J 1 kΩ
R28	7010003400	Resistor	ELR20J 1 kΩ
R29	7010003400	Resistor	ELR20J 1 kΩ
R30	7010003400	Resistor	ELR20J 1 kΩ
R31	7010003400	Resistor	ELR20J 1 kΩ
R32	7010003400	Resistor	ELR20J 1 kΩ
R33	7010003400	Resistor	ELR20J 1 kΩ
R34	7010003400	Resistor	ELR20J 1 kΩ
R35	7010003400	Resistor	ELR20J 1 kΩ
R36	7010003400	Resistor	ELR20J 1 kΩ
R37	7010003400	Resistor	ELR20J 1 kΩ
R38	7010003400	Resistor	ELR20J 1 kΩ
R39	7010003400	Resistor	ELR20J 1 kΩ
R40	7010003400	Resistor	ELR20J 1 kΩ
R41	7010003400	Resistor	ELR20J 1 kΩ
R42	7010003400	Resistor	ELR20J 1 kΩ
R43	7010003400	Resistor	ELR20J 1 kΩ
R44	7010003400	Resistor	ELR20J 1 kΩ
R45	7010003400	Resistor	ELR20J 1 kΩ
R46	7010003400	Resistor	ELR20J 1 kΩ
R47	7010003400	Resistor	ELR20J 1 kΩ
R48	7010003400	Resistor	ELR20J 1 kΩ
R49	7010003400	Resistor	ELR20J 1 kΩ
R50	7010003400	Resistor	ELR20J 1 kΩ
R51	7010003400	Resistor	ELR20J 1 kΩ
R52	7010003400	Resistor	ELR20J 1 kΩ
R53	7010003400	Resistor	ELR20J 1 kΩ
R54	7010003400	Resistor	ELR20J 1 kΩ
R55	7010003400	Resistor	ELR20J 1 kΩ
R56	7010003400	Resistor	ELR20J 1 kΩ
R57	7010003400	Resistor	ELR20J 1 kΩ
R58	7010003400	Resistor	ELR20J 1 kΩ
R59	7010003400	Resistor	ELR20J 1 kΩ
R60	7010003400	Resistor	ELR20J 1 kΩ
R61	7010003400	Resistor	ELR20J 1 kΩ

[LOGIC UNIT]

REF. NO.	ORDER NO.	DESCRIPTION	
R62	7010003400	Resistor	ELR20J 1 kΩ
R63	7010003400	Resistor	ELR20J 1 kΩ
R64	7010003400	Resistor	ELR20J 1 kΩ
R65	7010003400	Resistor	ELR20J 1 kΩ
R66	7010003400	Resistor	ELR20J 1 kΩ
R67	7010003400	Resistor	ELR20J 1 kΩ
R68	7010003400	Resistor	ELR20J 1 kΩ
R69	7010003400	Resistor	ELR20J 1 kΩ
R70	7010003400	Resistor	ELR20J 1 kΩ
R71	7010003400	Resistor	ELR20J 1 kΩ
R72	7010003400	Resistor	ELR20J 1 kΩ
R73	7010003400	Resistor	ELR20J 1 kΩ
R74	7010003400	Resistor	ELR20J 1 kΩ
R75	7010003400	Resistor	ELR20J 1 kΩ
R76	7010003400	Resistor	ELR20J 1 kΩ
R77	7010003400	Resistor	ELR20J 1 kΩ
R78	7010003400	Resistor	ELR20J 1 kΩ
R79	7010003780	Resistor	ELR20J 1 MΩ
R80	7010003530	Resistor	ELR20J 10 kΩ
R81	7010003780	Resistor	ELR20J 1 MΩ
R82	7010003580	Resistor	ELR20J 22 kΩ
R83	7010003580	Resistor	ELR20J 22 kΩ
R84	7010003590	Resistor	ELR20J 27 kΩ
R85	7010003580	Resistor	ELR20J 22 kΩ
R86	7010003590	Resistor	ELR20J 27 kΩ
R87	7410000150	Resistor Array	RMX- 6 473K
R88	7410000080	Resistor Array	RMX- 4 473K
R89	7410000080	Resistor Array	RMX- 4 473K
R90	7010003530	Resistor	ELR20J 10 kΩ
R91	7010003630	Resistor	ELR20J 56 kΩ
R92	7010003480	Resistor	ELR20J 4.7 kΩ
R93	7010003440	Resistor	ELR20J 2.2 kΩ
R94	7010003620	Resistor	ELR20J 47 kΩ
R95	7010003620	Resistor	ELR20J 47 kΩ
R96	7010003620	Resistor	ELR20J 47 kΩ
R97	7010003710	Resistor	ELR20J 270 kΩ
R98	7010003620	Resistor	ELR20J 47 kΩ
R99	7010003400	Resistor	ELR20J 1 kΩ
R100	7010003400	Resistor	ELR20J 1 kΩ
R101	7010003400	Resistor	ELR20J 1 kΩ
R102	7010003400	Resistor	ELR20J 1 kΩ
R103	7010003400	Resistor	ELR20J 1 kΩ
R104	7010003620	Resistor	ELR20J 47 kΩ
R105	7010003530	Resistor	ELR20J 10 kΩ
R106	7010003400	Resistor	ELR20J 1 kΩ
R107	7010003480	Resistor	ELR20J 4.7 kΩ
R108	7010003530	Resistor	ELR20J 10 kΩ
R109	7010003530	Resistor	ELR20J 10 kΩ
R110	7010003520	Resistor	ELR20J 8.2 kΩ
R111	7010003520	Resistor	ELR20J 8.2 kΩ
R112	7010003280	Resistor	ELR20J 100 Ω
R113	7010003620	Resistor	ELR20J 47 kΩ
R114	7010003440	Resistor	ELR20J 2.2 kΩ
R115	7010003490	Resistor	ELR20J 5.6 kΩ
R116	7010003400	Resistor	ELR20J 1 kΩ
R117	7010003400	Resistor	ELR20J 1 kΩ
R118	7010003400	Resistor	ELR20J 1 kΩ
R119	7010003400	Resistor	ELR20J 1 kΩ
R121	7010003280	Resistor	ELR20J 100 Ω
R122	7010003280	Resistor	ELR20J 100 Ω
R123	7010003280	Resistor	ELR20J 100 Ω
R124	7010003480	Resistor	ELR20J 3.3 kΩ
R125	7010003720	Resistor	ELR20J 330 kΩ
R126	7010003680	Resistor	ELR20J 100 kΩ
R127	7010003680	Resistor	ELR20J 100 kΩ
R129	7010003340	Resistor	ELR20J 330 Ω
R130	7010003620	Resistor	ELR20J 47 kΩ
R131	7010003400	Resistor	ELR20J 1 kΩ
R132	7010003400	Resistor	ELR20J 1 kΩ
R133	7010003400	Resistor	ELR20J 1 kΩ
R134	7010003530	Resistor	ELR20J 10 kΩ
R135	7410000150	Resistor Array	RMX- 6 473K
R136	7010003440	Resistor	ELR20J 2.2 kΩ
R137	7010003620	Resistor	ELR20J 47 kΩ
R138	7010003620	Resistor	ELR20J 47 kΩ
R139	7010003620	Resistor	ELR20J 47 kΩ
R140	7010003530	Resistor	ELR20J 10 kΩ
R141	7010003680	Resistor	ELR20J 100 kΩ

[LOGIC UNIT]

REF. NO.	ORDER NO.	DESCRIPTION
R142	7010003400	Resistor ELR20J 1 kΩ
R143	7010003400	Resistor ELR20J 1 kΩ
R144	7010003400	Resistor ELR20J 1 kΩ
R145	7010003400	Resistor ELR20J 1 kΩ
R146	7010003440	Resistor ELR20J 2.2 kΩ
R147	7010003440	Resistor ELR20J 2.2 kΩ
R148	7010003440	Resistor ELR20J 2.2 kΩ
R149	7010003440	Resistor ELR20J 2.2 kΩ
R150	7410000220	Resistor Array RMX- 8 473K
R151	7410000220	Resistor Array RMX- 8 473K
R152	7410000220	Resistor Array RMX- 8 473K
R153	7410000220	Resistor Array RMX- 8 473K
R154	7410000220	Resistor Array RMX- 8 473K
R155	7410000220	Resistor Array RMX- 8 473K
R156	7410000220	Resistor Array RMX- 8 473K
R157	7410000220	Resistor Array RMX- 8 473K
R158	7410000220	Resistor Array RMX- 8 473K
R159	7010003820	Resistor ELR20J 3.3 MΩ
R160	7010003750	Resistor ELR20J 560 kΩ
R161	7010003740	Resistor ELR20J 470 kΩ
R162	7010003680	Resistor ELR20J 100 kΩ
R163	7010003820	Resistor ELR20J 3.3 MΩ
R164	7010003750	Resistor ELR20J 560 kΩ
R165	7010003740	Resistor ELR20J 470 kΩ
R166	7010003680	Resistor ELR20J 100 kΩ
R167	7010003620	Resistor ELR20J 47 kΩ
R168	7010003530	Resistor ELR20J 10 kΩ
R169	7010003580	Resistor ELR20J 22 kΩ
R170	7010003550	Resistor ELR20J 15 kΩ
R171	7010003550	Resistor ELR20J 15 kΩ
R172	7010003620	Resistor ELR20J 47 kΩ
R173	7010003620	Resistor ELR20J 47 kΩ
R174	7010003680	Resistor ELR20J 100 kΩ
R175	7010003670	Resistor ELR20J 120 kΩ
R178	7010003550	Resistor ELR20J 15 kΩ
R179	7010003620	Resistor ELR20J 47 kΩ
R180	7010003550	Resistor ELR20J 15 kΩ
R181	7010003550	Resistor ELR20J 15 kΩ
R182	7010003620	Resistor ELR20J 47 kΩ
R183	7010003580	Resistor ELR20J 22 kΩ
R184	7010003790	Resistor ELR20J 1.2 MΩ
R185	7010003620	Resistor ELR20J 47 kΩ
R190	7010003530	Resistor ELR20J 10 kΩ
R191	7010003530	Resistor ELR20J 10 kΩ
R192	7010003670	Resistor ELR20J 120 kΩ
R193	7010004670	Resistor R50XJ 22 Ω
R194	7010004670	Resistor R50XJ 22 Ω
R195	7010003820	Resistor ELR20J 3.3 MΩ
R197	7010003720	Resistor ELR20J 330 kΩ
R198	7010003620	Resistor ELR20J 47 kΩ
R199	7010003440	Resistor ELR20J 2.2 kΩ
R200	7010003440	Resistor ELR20J 2.2 kΩ
R201	7010003440	Resistor ELR20J 2.2 kΩ
R202	7010003400	Resistor ELR20J 1 kΩ
R203	7010003400	Resistor ELR20J 1 kΩ
R204	7010003530	Resistor ELR20J 10 kΩ
R205	7010003670	Resistor ELR20J 120 kΩ
R206	7010003670	Resistor ELR20J 120 kΩ
R207	7010003530	Resistor ELR20J 10 kΩ
R209	7010003400	Resistor ELR20J 1 kΩ
R210	7010003400	Resistor ELR20J 1 kΩ
R212	7010003530	Resistor ELR20J 10 kΩ
R213	7010003530	Resistor ELR20J 10 kΩ
R214	7010003530	Resistor ELR20J 10 kΩ
R215	7010003620	Resistor ELR20J 47 kΩ
R216	7010003530	Resistor ELR20J 10 kΩ
R217	7010003530	Resistor ELR20J 10 kΩ
R218	7010003530	Resistor ELR20J 10 kΩ
R219	7010003530	Resistor ELR20J 10 kΩ
C1	4010000500	Ceramic DD104 B 102K 50V
C2	4530000030	Capacitor Array B5RC0124-32N
C3	4530000030	Capacitor Array B5RC0124-32N
C4	4530000030	Capacitor Array B5RC0124-32N
C5	4530000030	Capacitor Array B5RC0124-32N
C6	4530000190	Capacitor Array B7ZC0716-32N
C7	4530000190	Capacitor Array B7ZC0716-32N

[LOGIC UNIT]

REF. NO.	ORDER NO.	DESCRIPTION
C8	4530000030	Capacitor Array B5RC0124-32N
C9	4530000190	Capacitor Array B7ZC0716-32N
C10	4010000500	Ceramic DD104 B 102K 50V
C11	4010000500	Ceramic DD104 B 102K 50V
C12	4010000500	Ceramic DD104 B 102K 50V
C13	4010000500	Ceramic DD104 B 102K 50V
C14	4530000190	Capacitor Array B7ZC0716-32N
C15	4530000190	Capacitor Array B7ZC0716-32N
C16	4530000190	Capacitor Array B7ZC0716-32N
C17	4010000500	Ceramic DD104 B 102K 50V
C18	4010000500	Ceramic DD104 B 102K 50V
C19	4010000500	Ceramic DD104 B 102K 50V
C20	4010000500	Ceramic DD104 B 102K 50V
C21	4010000500	Ceramic DD104 B 102K 50V
C22	4010000500	Ceramic DD104 B 102K 50V
C23	4010000500	Ceramic DD104 B 102K 50V
C24	4010000500	Ceramic DD104 B 102K 50V
C25	4010000500	Ceramic DD104 B 102K 50V
C26	4530000030	Capacitor Array B5RC0124-32N
C27	4010000260	Ceramic DD104 SL 470J 50V
C28	4010000180	Ceramic DD104 SL 220J 50V
C29	4010000180	Ceramic DD104 SL 220J 50V
C30	4510003880	Electrolytic 10 MV 47 HW
C33	4510003800	Electrolytic 25 MV 4R7 SW
C34	4010000500	Ceramic DD104 B 102K 50V
C35	4010000500	Ceramic DD104 B 102K 50V
C36	4010000500	Ceramic DD104 B 102K 50V
C42	4010004840	Ceramic DD305 F 104Z 12V
C43	4010004840	Ceramic DD305 F 104Z 12V
C44	4010000180	Ceramic DD104 SL 220J 50V
C45	4010000180	Ceramic DD104 SL 220J 50V
C48	4550000380	Tantalum DN 1A 100M
C49	4310000120	Mylar F2D 50V 473K
C50	4010000500	Ceramic DD104 B 102K 50V
C51	4010004120	Ceramic DD07 B 102K 500V
C52	4010004120	Ceramic DD07 B 102K 500V
C53	4010000500	Ceramic DD104 B 102K 50V
C54	4010000500	Ceramic DD104 B 102K 50V
C55	4010000500	Ceramic DD104 B 102K 50V
C56	4530000030	Capacitor Array B5RC0124-32N
C57	4010000500	Ceramic DD104 B 102K 50V
C58	4530000030	Capacitor Array B5RC0124-32N
C59	4010000500	Ceramic DD104 B 102K 50V
C60	4510003950	Electrolytic 50 MV R47 HW
C61	4010004840	Ceramic DD305 F 104Z 12V
C62	4010004840	Ceramic DD305 F 104Z 12V
C63	4010004840	Ceramic DD305 F 104Z 12V
C64	4010004840	Ceramic DD305 F 104Z 12V
C65	4010004840	Ceramic DD305 F 104Z 12V
C66	4010004840	Ceramic DD305 F 104Z 12V
C67	4010004840	Ceramic DD305 F 104Z 12V
C68	4010004840	Ceramic DD305 F 104Z 12V
C69	4010004840	Ceramic DD305 F 104Z 12V
C70	4010004840	Ceramic DD305 F 104Z 12V
C71	4010004840	Ceramic DD305 F 104Z 12V
C72	4010004840	Ceramic DD305 F 104Z 12V
C73	4010004840	Ceramic DD305 F 104Z 12V
C74	4010004840	Ceramic DD305 F 104Z 12V
C75	4010004840	Ceramic DD305 F 104Z 12V
C76	4010004840	Ceramic DD305 F 104Z 12V
C77	4010004840	Ceramic DD305 F 104Z 12V
C78	4010004840	Ceramic DD305 F 104Z 12V
C79	4010004840	Ceramic DD305 F 104Z 12V
C80	4010004840	Ceramic DD305 F 104Z 12V
C81	4010004840	Ceramic DD305 F 104Z 12V
C82	4010004840	Ceramic DD305 F 104Z 12V
C83	4010004840	Ceramic DD305 F 104Z 12V
C84	4010004840	Ceramic DD305 F 104Z 12V
C85	4010004840	Ceramic DD305 F 104Z 12V
C86	4010004840	Ceramic DD305 F 104Z 12V
C87	4010004840	Ceramic DD305 F 104Z 12V
C88	4010004840	Ceramic DD305 F 104Z 12V
C89	4040000260	Barrier Layer UZE 08X 104M
C90	4010004840	Ceramic DD305 F 104Z 12V
C91	4040000260	Barrier Layer UZE 08X 104M
C92	4010004840	Ceramic DD305 F 104Z 12V
C94	4010000500	Ceramic DD104 B 102K 50V
C95	4010000500	Ceramic DD104 B 102K 50V

[LOGIC UNIT]

REF. NO.	ORDER NO.	DESCRIPTION
C96	4010004840	Ceramic DD305 F 104Z 12V
C97	4010004840	Ceramic DD305 F 104Z 12V
C99	4530000030	Capacitor Array B5RC0124-32N
C100	4010000500	Ceramic DD104 B 102K 50V
C101	4010000500	Ceramic DD104 B 102K 50V
C102	4010000500	Ceramic DD104 B 102K 50V
C104	4010000500	Ceramic DD104 B 102K 50V
C105	4010000500	Ceramic DD104 B 102K 50V
C108	4510003920	Electrolytic 16 MV 100 HW
C110	4510003920	Electrolytic 16 MV 100 HW
C111	4510003980	Electrolytic 10 MV 100 HWS (5X11)
C112	4010004840	Ceramic DD305 F 104Z 12V
C114	4010000500	Ceramic DD104 B 102K 50V
C115	4010000500	Ceramic DD104 B 102K 50V
S1	2220000420	Switch ESD11H120
S3	2220000420	Switch ESD11H120
S4	2220000420	Switch ESD11H120
SO1	6510008370	Switch BBH-1
SO2	2610000200	Socket ICC05-028 360T
SO1	6510008370	Switch BBH-1
SO2	2610000200	Socket ICC05-028 360T
BT1	3020000110	Lithium Battery CR2032
EP1	0910024114	P.C. Board B 2262D (LOGIC)

[MAIN UNIT]

REF. NO.	ORDER NO.	DESCRIPTION
IC22	1110001310	IC μ PC577HA
IC23	1180000580	IC TA78DL10P
Q1	1580000110	FET 3SK74 M
Q2	1530000591	Transistor 2SC2785 EL
Q3	1590000360	Transistor RN2202
Q4	1560000080	FET 2SK192A-Y
Q5	1510000070	Transistor 2SA1048-Y
Q6	1530000591	Transistor 2SC2785 EL
Q7	1530000591	Transistor 2SC2785 EL
Q8	1590000360	Transistor RN2202
Q9	1530000591	Transistor 2SC2785 EL
Q10	1530000591	Transistor 2SC2785 EL
Q11	1580000110	FET 3SK74 M
Q12	1530000591	Transistor 2SC2785 EL
Q13	1530000591	Transistor 2SC2785 EL
Q14	1590000350	Transistor RN1204
Q15	1590000350	Transistor RN1204
Q16	1590000350	Transistor RN1204
Q17	1590000350	Transistor RN1204
Q18	1590000350	Transistor RN1204
Q19	1590000370	Transistor RN2204
Q20	1530000591	Transistor 2SC2785 EL
Q21	1590000310	FET 2SJ105-GR
Q22	1530000150	Transistor 2SC2668-O
Q23	1580000110	FET 3SK74 M
Q24	1580000110	FET 3SK74 M
Q25	1590000350	Transistor RN1204
Q26	1590000350	Transistor RN1204
Q27	1590000350	Transistor RN1204
Q28	1590000350	Transistor RN1204
Q29	1590000360	Transistor RN2202
Q30	1590000340	Transistor RN1202
Q31	1590000350	Transistor RN1204
Q32	1590000350	Transistor RN1204
Q33	1530002650	Transistor 2SC1384-R
Q34	1530002650	Transistor 2SC1384-R
Q35	1590000350	Transistor RN1204
Q36	1590000350	Transistor RN1204
Q37	1590000350	Transistor RN1204
Q38	1590000350	Transistor RN1204
Q39	1590000310	FET 2SJ105-GR
Q40	1590000350	Transistor RN1204
Q41	1530000591	Transistor 2SC2785 EL
Q42	1590000310	FET 2SJ105-GR
Q43	1530000591	Transistor 2SC2785 EL
Q44	1590000360	Transistor RN2202
Q45	1530000591	Transistor 2SC2785 EL
Q46	1530000591	Transistor 2SC2785 EL
Q47	1580000110	FET 3SK74 M
Q48	1580000110	FET 3SK74 M
Q49	1590000350	Transistor RN1204
Q50	1590000350	Transistor RN1204
Q51	1580000110	FET 3SK74 M
Q52	1590000350	Transistor RN1204
Q53	1590000350	Transistor RN1204
Q54	1590000340	Transistor RN1202
Q55	1590000350	Transistor RN1204
Q56	1590000360	Transistor RN2202
Q57	1590000350	Transistor RN1204
Q58	1590000350	Transistor RN1204
Q59	1530000591	Transistor 2SC2785 EL
Q60	1530000591	Transistor 2SC2785 EL
Q61	1530000591	Transistor 2SC2785 EL
Q62	1530000591	Transistor 2SC2785 EL
Q63	1590000310	FET 2SJ105-GR
Q64	1590000310	FET 2SJ105-GR
Q65	1590000350	Transistor RN1204
Q66	1530000591	Transistor 2SC2785 EL
Q67	1530000591	Transistor 2SC2785 EL
Q68	1530000591	Transistor 2SC2785 EL
Q69	1590000350	Transistor RN1204
Q71	1530000591	Transistor 2SC2785 EL
Q72	1530000591	Transistor 2SC2785 EL
Q73	1590000350	Transistor RN1204
Q74	1530000591	Transistor 2SC2785 EL
Q75	1530000591	Transistor 2SC2785 EL

[MAIN UNIT]

REF. NO.	ORDER NO.	DESCRIPTION
IC1	1110001310	IC μ PC577HA
IC2	1110001930	IC M5215TL
IC3	1110001320	IC μ PC1037HA
IC4	1110000290	IC BA618
IC5	1110000630	IC MC3357P
IC6	1110001310	IC μ PC577HA
IC7	1110001320	IC μ PC1037HA
IC8	1130003900	IC GD4066B
IC9	1130003900	IC GD4066B
IC10	1110002500	IC M5218AL
IC11	1110000630	IC MC3357P
IC12	1110001310	IC μ PC577HA
IC13	1110001320	IC μ PC1037HA
IC14	1110000290	IC BA618
IC15	1130003900	IC GD4066B
IC16	1110002060	IC M51131L
IC17	1110001980	IC TA8207K
IC18	1110002030	IC TA7808S
IC19	1110000240	IC BA222-V
IC20	1110001320	IC μ PC1037HA
IC21	1110001320	IC μ PC1037HA

[MAIN UNIT]

REF. NO.	ORDER NO.	DESCRIPTION	
Q76	1590000350	Transistor	RN1204 (IC-970M/970D)
Q77	1560000080	FET	2SK192A-Y
Q78	1510000070	Transistor	2SA1048-Y
Q79	1530000591	Transistor	2SC2785 EL
Q80	1530000591	Transistor	2SC2785 EL
Q81	1590000360	Transistor	RN2202
Q82	1510000070	Transistor	2SA1048-Y
Q83	1590000340	Transistor	RN1202
Q86	1590000340	Transistor	RN1202 (IC-970D only)
Q87	1590000340	Transistor	RN1202 (IC-970D only)
Q91	1590000310	FET	2SJ105-GR
Q92	1530000110	Transistor	2SC2458-GR
Q93	1510000070	Transistor	2SA1048-Y
Q95	1590000350	Transistor	RN1204
Q96	1590000310	FET	2SJ105-GR
Q97	1530000110	Transistor	2SC2458-GR
Q99	1590000350	Transistor	RN1204
Q100	1590000350	Transistor	RN1204
Q101	1590000350	Transistor	RN1204
Q102	1590000350	Transistor	RN1204
Q103	1590000350	Transistor	RN1204
Q104	1590000350	Transistor	RN1204
Q105	1590000370	Transistor	RN2204
D1	1710000050	Diode	1SS53
D2	1710000050	Diode	1SS53
D3	1710000050	Diode	1SS53
D4	1710000050	Diode	1SS53
D5	1710000050	Diode	1SS53
D6	1710000050	Diode	1SS53
D7	1710000050	Diode	1SS53
D8	1710000050	Diode	1SS53
D9	1710000050	Diode	1SS53
D10	1710000050	Diode	1SS53
D11	1710000050	Diode	1SS53
D12	1710000160	Diode	1SS133
D13	1710000160	Diode	1SS133
D14	1710000330	Diode	1K60
D15	1710000330	Diode	1K60
D16	1720000060	Varicap	1SV50(1E)
D17	1710000050	Diode	1SS53
D18	1710000050	Diode	1SS53
D19	1710000050	Diode	1SS53
D20	1710000050	Diode	1SS53
D21	1710000050	Diode	1SS53
D22	1710000050	Diode	1SS53
D23	1710000050	Diode	1SS53
D24	1710000050	Diode	1SS53
D25	1710000050	Diode	1SS53
D26	1710000050	Diode	1SS53
D27	1710000160	Diode	1SS133
D28	1710000050	Diode	1SS53
D29	1710000160	Diode	1SS133
D30	1710000160	Diode	1SS133
D31	1710000160	Diode	1SS133
D32	1710000160	Diode	1SS133
D33	1710000050	Diode	1SS53
D34	1710000050	Diode	1SS53
D35	1710000050	Diode	1SS53
D36	1710000160	Diode	1SS133
D37	1730000120	Zener	RD6.2E B2
D38	1710000050	Diode	1SS53
D39	1710000050	Diode	1SS53
D40	1790000070	Diode	1SS237
D41	1790000070	Diode	1SS237
D42	1790000070	Diode	1SS237
D43	1790000070	Diode	1SS237
D44	1710000050	Diode	1SS53
D45	1720000120	Varicap	FC52M
D46	1710000160	Diode	1SS133
D47	1710000160	Diode	1SS133
D48	1710000160	Diode	1SS133
D49	1710000160	Diode	1SS133
D50	1710000160	Diode	1SS133

[MAIN UNIT]

REF. NO.	ORDER NO.	DESCRIPTION	
D51	1710000160	Diode	1SS133
D52	1710000160	Diode	1SS133
D53	1710000160	Diode	1SS133
D54	1710000160	Diode	1SS133
D55	1710000160	Diode	1SS133
D56	1710000160	Diode	1SS133
D57	1710000160	Diode	1SS133
D58	1710000160	Diode	1SS133
D59	1710000160	Diode	1SS133
D60	1710000160	Diode	1SS133
D61	1710000160	Diode	1SS133
D62	1710000160	Diode	1SS133
D63	1730000070	Zener	RD3.9E B2
D64	1730000120	Zener	RD6.2E B2
D65	1790000070	Diode	1SS237
D66	1790000070	Diode	1SS237
D67	1710000050	Diode	1SS53
D68	1710000050	Diode	1SS53
D69	1790000070	Diode	1SS237
D70	1790000070	Diode	1SS237
D72	1710000050	Diode	1SS53
D73	1710000050	Diode	1SS53
D74	1710000050	Diode	1SS53
D75	1710000050	Diode	1SS53
D76	1710000050	Diode	1SS53
D77	1710000050	Diode	1SS53
D78	1710000050	Diode	1SS53
D79	1710000050	Diode	1SS53
D80	1710000050	Diode	1SS53
D81	1710000160	Diode	1SS133
D82	1710000050	Diode	1SS53
D83	1710000050	Diode	1SS53
D84	1710000160	Diode	1SS133
D85	1710000160	Diode	1SS133
D86	1710000160	Diode	1SS133
D87	1710000160	Diode	1SS133
D88	1710000160	Diode	1SS133
D89	1710000160	Diode	1SS133
D90	1710000160	Diode	1SS133
D91	1710000160	Diode	1SS133
D92	1710000160	Diode	1SS133
D93	1710000160	Diode	1SS133
D94	1790000070	Diode	1SS237
D95	1730000100	Zener	RD5.1E B2
D96	1710000160	Diode	1SS133
D97	1710000160	Diode	1SS133
D98	1710000160	Diode	1SS133
D99	1710000330	Diode	1K60
D100	1710000330	Diode	1K60
D101	1710000160	Diode	1SS133
D102	1710000160	Diode	1SS133
D103	1710000160	Diode	1SS133
D104	1710000050	Diode	1SS53
D106	1710000160	Diode	1SS133
D107	1710000160	Diode	1SS133
D108	1710000050	Diode	1SS53
D109	1710000050	Diode	1SS53
D110	1710000050	Diode	1SS53
D111	1710000050	Diode	1SS53
D112	1710000050	Diode	1SS53
D113	1710000050	Diode	1SS53
D114	1710000050	Diode	1SS53
D115	1710000050	Diode	1SS53
D116	1710000160	Diode	1SS133
D117	1710000050	Diode	1SS53 (IC-970D only)
D118	1710000050	Diode	1SS53 (IC-970D only)
D119	1710000050	Diode	1SS53
D120	1710000050	Diode	1SS53
D122	1710000050	Diode	1SS53
D123	1710000050	Diode	1SS53
D124	1710000050	Diode	1SS53
D125	1710000050	Diode	1SS53
D126	1710000160	Diode	1SS133
D127	1710000160	Diode	1SS133
D128	1710000160	Diode	1SS133
D129	1710000160	Diode	1SS133

[MAIN UNIT]

REF. NO.	ORDER NO.	DESCRIPTION	
D130	1710000160	Diode	1SS133
D132	1710000160	Diode	1SS133
D133	1710000160	Diode	1SS133
D134	1710000160	Diode	1SS133
D135	1710000160	Diode	1SS133
D136	1710000160	Diode	1SS133
D137	1710000160	Diode	1SS133
X1	6050006440	Crystal	CR-297
X2	6050006430	Crystal	CR-296
X3	6050006450	Crystal	CR-298
X4	6050006440	Crystal	CR-297
X5	6050006470	Crystal	CR-301
X6	6070000010	Discriminator	CDB455C7A
X7	6050006460	Crystal	CR-299
F11	2010001080	Filter	10M22D6 (FL-128)
F12	2010001120	Filter	10M15BB (FL-142)
F13	2030000030	Ceramic Filter	KBF-455R-15A
F14	2030000030	Ceramic Filter	KBF-455R-15A
F15	2010001090	Filter	10M22D7 (FL-129)
F16	2010001130	Filter	10M15BC (FL-143)
L1	6150000470	Coil	LS-66A
L2	6150000470	Coil	LS-66A
L3	6180000900	Coil	LAL 03NA 101K
L4	6150000470	Coil	LS-66A
L5	6150000470	Coil	LS-66A
L6	6180000880	Coil	LAL 03NA 100K
L7	6180000900	Coil	LAL 03NA 101K
L8	6180000880	Coil	LAL 03NA 100K
L9	6180000260	Coil	LB4-100J
L10	6150002040	Coil	LS-256
L11	6150002990	Coil	LS-310
L12	6150002990	Coil	LS-310
L13	6150002890	Coil	LS-303
L14	6150002890	Coil	LS-303
L15	6150000470	Coil	LS-66A
L16	6180000900	Coil	LAL 03NA 101K
L17	6180000880	Coil	LAL 03NA 100K
L18	6180000900	Coil	LAL 03NA 101K
L19	6180000900	Coil	LAL 03NA 101K
L20	6150001360	Coil	LS-150A
L21	6150001350	Coil	LS-149A
L22	6180000690	Coil	LAL 03NA R22M
L23	6150001060	Coil	LS-121
L24	6180001710	Coil	LAL 03NA 561K
L25	6150001070	Coil	LS-121A
L26	6180000900	Coil	LAL 03NA 101K
L27	6180000950	Coil	LAL 03NA 150K
L28	6150002960	Coil	LS-307
L29	6150002990	Coil	LS-310
L30	6150000470	Coil	LS-66A
L31	6180000900	Coil	LAL 03NA 101K
L32	6910000670	Coil	BT01RN1-A61-001
L33	6180001710	Coil	LAL 03NA 561K
L34	6150001070	Coil	LS-121A
L35	6180000900	Coil	LAL 03NA 101K
L36	6150001360	Coil	LS-150A
L37	6180000690	Coil	LAL 03NA R22M
L38	6150002960	Coil	LS-307
L39	6150002990	Coil	LS-310
L40	6150000470	Coil	LS-66A
L41	6180000900	Coil	LAL 03NA 101K
L42	6150002990	Coil	LS-310
L43	6150002990	Coil	LS-310
L44	6150002890	Coil	LS-303
L45	6150000470	Coil	LS-66A
L46	6170000140	Coil	LW-15
L47	6180000900	Coil	LAL 03NA 101K
L48	6180000900	Coil	LAL 03NA 101K
L49	6180000900	Coil	LAL 03NA 101K
L50	6910000670	Coil	BT01RN1-A61-001
L51	6150002540	Coil	LS-282
L52	6180000900	Coil	LAL 03NA 101K

[MAIN UNIT]

REF. NO.	ORDER NO.	DESCRIPTION	
L53	6180000900	Coil	LAL 03NA 101K
L54	6180000900	Coil	LAL 03NA 101K
L55	6180000900	Coil	LAL 03NA 101K
L56	6180000900	Coil	LAL 03NA 101K
L57	6180000900	Coil	LAL 03NA 101K
L58	6180001710	Coil	LAL 03NA 561K
L59	6180000900	Coil	LAL 03NA 101K
L60	6180000960	Coil	LAL 03NA 102K
L61	6180000960	Coil	LAL 03NA 102K
L62	6180000950	Coil	LAL 03NA 150K
L63	6150000470	Coil	LS-66A
L64	6150000470	Coil	LS-66A
L65	6150002890	Coil	LS-303
L66	6180000900	Coil	LAL 03NA 101K
R1	7010003440	Resistor	ELR20J 2.2 kΩ
R2	7310003170	Trimmer	EVN-2ACA00 B53 (502)
R3	7010004070	Resistor	R20J 100 Ω
R4	7510000230	Thermistor	ERT-D2ZGL251S
R5	7010003200	Resistor	ELR20J 22 Ω
R6	7010003330	Resistor	ELR20J 270 Ω
R7	7010003740	Resistor	ELR20J 470 kΩ
R8	7010003740	Resistor	ELR20J 470 kΩ
R9	7010004270	Resistor	R20J 4.7 kΩ
R10	7010004270	Resistor	R20J 4.7 kΩ
R11	7010003320	Resistor	ELR20J 220 Ω
R12	7010003480	Resistor	ELR20J 4.7 kΩ
R13	7010001230	Resistor	R25XJ 4.7 kΩ
R14	7010004190	Resistor	R20J 1 kΩ
R15	7010001030	Resistor	R25XJ 100 Ω
R16	7010004210	Resistor	R20J 1.5 kΩ
R17	7010003440	Resistor	ELR20J 2.2 kΩ
R18	7010004070	Resistor	R20J 100 Ω
R19	7010004320	Resistor	R20J 10 kΩ
R20	7010003480	Resistor	ELR20J 4.7 kΩ
R21	7010004190	Resistor	R20J 1 kΩ
R22	7010001030	Resistor	R25XJ 100 Ω
R23	7010003440	Resistor	ELR20J 2.2 kΩ
R24	7010004210	Resistor	R20J 1.5 kΩ
R25	7010004320	Resistor	R20J 10 kΩ
R26	7010003580	Resistor	ELR20J 22 kΩ
R27	7010004270	Resistor	R20J 4.7 kΩ
R28	7310003210	Trimmer	EVN-2ACA00 B54 (503)
R29	7010003280	Resistor	ELR20J 100 Ω
R30	7310003170	Trimmer	EVN-2ACA00 B53 (502)
R31	7010003660	Resistor	ELR20J 100 kΩ
R32	7010004070	Resistor	R20J 100 Ω
R33	7010003480	Resistor	ELR20J 4.7 kΩ
R34	7010003660	Resistor	ELR20J 100 kΩ
R35	7010003280	Resistor	ELR20J 100 Ω
R36	7010003740	Resistor	ELR20J 470 kΩ
R37	7010003620	Resistor	ELR20J 47 kΩ
R38	7010003530	Resistor	ELR20J 10 kΩ
R39	7010004090	Resistor	R20J 150 Ω
R40	7010003490	Resistor	ELR20J 5.6 kΩ
R41	7010003360	Resistor	ELR20J 470 Ω
R42	7010004070	Resistor	R20J 100 Ω
R43	7010003480	Resistor	ELR20J 4.7 kΩ
R44	7310003160	Trimmer	EVN-2ACA00 B13 (102)
R45	7010004150	Resistor	R20J 470 Ω
R46	7010003400	Resistor	ELR20J 1 kΩ
R47	7010003580	Resistor	ELR20J 22 kΩ
R48	7010003590	Resistor	ELR20J 27 kΩ
R49	7010003580	Resistor	ELR20J 22 kΩ
R50	7010003440	Resistor	ELR20J 2.2 kΩ
R51	7010003620	Resistor	ELR20J 47 kΩ
R52	7010003740	Resistor	ELR20J 470 kΩ
R53	7010003480	Resistor	ELR20J 4.7 kΩ
R54	7010003590	Resistor	ELR20J 27 kΩ
R55	7510000310	Thermistor	ERT-D2ZHL802S
R56	7010003540	Resistor	ELR20J 12 kΩ
R57	7010004270	Resistor	R20J 4.7 kΩ
R58	7010003280	Resistor	ELR20J 100 Ω
R59	7010003400	Resistor	ELR20J 1 kΩ
R60	7010003720	Resistor	ELR20J 330 kΩ
R61	7010003620	Resistor	ELR20J 47 kΩ
R62	7010003610	Resistor	ELR20J 39 kΩ

[MAIN UNIT]

REF. NO.	ORDER NO.	DESCRIPTION
R63	7310003210	Trimmer EVN-2ACA00 B54 (503)
R64	7010003620	Resistor ELR20J 47 kΩ
R65	7310003210	Trimmer EVN-2ACA00 B54 (503)
R68	7010003440	Resistor ELR20J 2.2 kΩ
R69	7010003440	Resistor ELR20J 2.2 kΩ
R70	7010001190	Resistor R25XJ 2.2 kΩ
R71	7010004230	Resistor R20J 2.2 kΩ
R72	7010004230	Resistor R20J 2.2 kΩ
R73	7010003320	Resistor ELR20J 220 Ω
R74	7010004030	Resistor R20J 47 Ω
R75	7010003400	Resistor ELR20J 1 kΩ
R76	7010003740	Resistor ELR20J 470 kΩ
R77	7010003530	Resistor ELR20J 10 kΩ
R78	7510000300	Thermistor ERT-D2ZGL601S
R79	7010003310	Resistor ELR20J 180 Ω
R80	7010004110	Resistor R20J 220 Ω
R81	7010003480	Resistor ELR20J 4.7 kΩ
R82	7010004270	Resistor R20J 4.7 kΩ
R83	7010003440	Resistor ELR20J 2.2 kΩ
R84	7010003700	Resistor ELR20J 220 kΩ
R85	7310003200	Trimmer EVN-2ACA00 B14 (103)
R86	7010004490	Resistor R20J 220 kΩ
R87	7310003200	Trimmer EVN-2ACA00 B14 (103)
R88	7010003280	Resistor ELR20J 100 Ω
R89	7010003440	Resistor ELR20J 2.2 kΩ
R90	7010003280	Resistor ELR20J 100 Ω
R91	7010003660	Resistor ELR20J 100 kΩ
R92	7010004230	Resistor R20J 2.2 kΩ
R93	7010003620	Resistor ELR20J 47 kΩ
R94	7010004230	Resistor R20J 2.2 kΩ
R95	7010003530	Resistor ELR20J 10 kΩ
R96	7010003580	Resistor ELR20J 22 kΩ
R97	7010004370	Resistor R20J 22 kΩ
R98	7010004270	Resistor R20J 4.7 kΩ
R99	7010003460	Resistor ELR20J 3.3 kΩ
R100	7010003480	Resistor ELR20J 4.7 kΩ
R101	7010004270	Resistor R20J 4.7 kΩ
R102	7010004230	Resistor R20J 2.2 kΩ
R103	7010003440	Resistor ELR20J 2.2 kΩ
R104	7310003200	Trimmer EVN-2ACA00 B14 (103)
R105	7010003440	Resistor ELR20J 2.2 kΩ
R106	7010003530	Resistor ELR20J 10 kΩ
R107	7010004370	Resistor R20J 22 kΩ
R108	7010003580	Resistor ELR20J 22 kΩ
R109	7010004330	Resistor R20J 12 kΩ
R110	7010004270	Resistor R20J 4.7 kΩ
R111	7010003780	Resistor ELR20J 1 MΩ
R113	7010003650	Resistor ELR20J 82 kΩ
R114	7310003200	Trimmer EVN-2ACA00 B14 (103) (IC-970/970D)
R115	7010004070	Resistor R20J 100 Ω
R116	7310003200	Trimmer EVN-2ACA00 B14 (103)
R117	7310003200	Trimmer EVN-2ACA00 B14 (103)
R118	7310003190	Trimmer EVN-2ACA00 B34 (303)
R119	7010003480	Resistor ELR20J 4.7 kΩ
R120	7310003170	Trimmer EVN-2ACA00 B53 (502)
R121	7310003200	Trimmer EVN-2ACA00 B14 (103)
R122	7010004320	Resistor R20J 10 kΩ
R123	7010004530	Resistor R20J 470 kΩ
R124	7010003610	Resistor ELR20J 39 kΩ
R125	7010003620	Resistor ELR20J 47 kΩ
R126	7010003420	Resistor ELR20J 1.5 kΩ
R127	7010004210	Resistor R20J 1.5 kΩ
R128	7010004070	Resistor R20J 100 Ω
R129	7510000071	Thermistor ERT-D2ZHL503S
R130	7010004370	Resistor R20J 22 kΩ
R131	7010003400	Resistor ELR20J 1 kΩ
R132	7010003620	Resistor ELR20J 47 kΩ
R133	7310003170	Trimmer EVN-2ACA00 B53 (502)
R134	7010003640	Resistor ELR20J 68 kΩ
R135	7010003580	Resistor ELR20J 22 kΩ
R136	7010003630	Resistor ELR20J 56 kΩ
R137	7310003160	Trimmer EVN-2ACA00 B13 (102)
R138	7310003210	Trimmer EVN-2ACA00 B54 (503)
R139	7310003220	Trimmer EVN-2ACA00 B16 (105)
R140	7010001190	Resistor R25XJ 2.2 kΩ
R141	7010003440	Resistor ELR20J 2.2 kΩ
R142	7010003740	Resistor ELR20J 470 kΩ

[MAIN UNIT]

REF. NO.	ORDER NO.	DESCRIPTION
R143	7010003360	Resistor ELR20J 470 Ω
R144	7010003470	Resistor ELR20J 3.9 kΩ
R145	7010003300	Resistor ELR20J 150 Ω
R146	7010004070	Resistor R20J 100 Ω
R147	7010003580	Resistor ELR20J 22 kΩ
R148	7510000071	Thermistor ERT-D2ZHL503S
R149	7310003180	Trimmer EVN-2ACA00 B24 (203)
R150	7010003530	Resistor ELR20J 10 kΩ
R151	7010003530	Resistor ELR20J 10 kΩ
R152	7010003280	Resistor ELR20J 100 Ω
R153	7010003460	Resistor ELR20J 3.3 kΩ
R154	7010004210	Resistor R20J 1.5 kΩ
R155	7010003550	Resistor ELR20J 15 kΩ
R156	7010003530	Resistor ELR20J 10 kΩ
R157	7310003210	Trimmer EVN-2ACA00 B54 (503)
R158	7310003230	Trimmer EVN-2ACA00 B15 (104)
R159	7010004320	Resistor R20J 10 kΩ
R160	7310003200	Trimmer EVN-2ACA00 B14 (103)
R161	7010003530	Resistor ELR20J 10 kΩ
R162	7310003200	Trimmer EVN-2ACA00 B14 (103)
R163	7010003440	Resistor ELR20J 2.2 kΩ
R164	7010004410	Resistor R20J 47 kΩ
R165	7010003620	Resistor ELR20J 47 kΩ
R166	7010003620	Resistor ELR20J 47 kΩ
R167	7010004320	Resistor R20J 10 kΩ
R168	7010004370	Resistor R20J 22 kΩ
R169	7010003620	Resistor ELR20J 47 kΩ
R170	7010003620	Resistor ELR20J 47 kΩ
R171	7010003620	Resistor ELR20J 47 kΩ
R172	7010004410	Resistor R20J 47 kΩ
R173	7010000090	Resistor ELR25J 4.7 Ω
R174	7010000370	Resistor ELR25J 1 kΩ
R175	7010000090	Resistor ELR25J 4.7 Ω
R176	7010000370	Resistor ELR25J 1 kΩ
R177	7010003280	Resistor ELR20J 100 Ω
R178	7010004400	Resistor R20J 39 kΩ
R179	7010004410	Resistor R20J 47 kΩ
R180	7310003200	Trimmer EVN-2ACA00 B14 (103)
R181	7010003480	Resistor ELR20J 4.7 kΩ
R182	7010003620	Resistor ELR20J 47 kΩ
R183	7010003530	Resistor ELR20J 10 kΩ
R184	7010003740	Resistor ELR20J 470 kΩ
R186	7010003660	Resistor ELR20J 100 kΩ
R187	7010003660	Resistor ELR20J 100 kΩ
R188	7010004600	Resistor R20J 2.2 MΩ
R189	7010003810	Resistor ELR20J 2.2 MΩ
R191	7010004320	Resistor R20J 10 kΩ
R192	7010003530	Resistor ELR20J 10 kΩ
R193	7010003530	Resistor ELR20J 10 kΩ
R194	7010003660	Resistor ELR20J 100 kΩ
R195	7010003660	Resistor ELR20J 100 kΩ
R196	7010003810	Resistor ELR20J 2.2 MΩ
R197	7010003810	Resistor ELR20J 2.2 MΩ
R198	7010003530	Resistor ELR20J 10 kΩ
R199	7010003620	Resistor ELR20J 47 kΩ
R200	7010003420	Resistor ELR20J 1.5 kΩ
R201	7010003620	Resistor ELR20J 47 kΩ
R202	7010003420	Resistor ELR20J 1.5 kΩ
R203	7010004210	Resistor R20J 1.5 kΩ
R204	7010004370	Resistor R20J 22 kΩ
R205	7010004070	Resistor R20J 100 Ω
R206	7510000071	Thermistor ERT-D2ZHL503S
R207	7010003780	Resistor ELR20J 1 MΩ
R208	7010004150	Resistor R20J 470 Ω
R209	7010003400	Resistor ELR20J 1 kΩ
R210	7010004410	Resistor R20J 47 kΩ
R211	7310003170	Trimmer EVN-2ACA00 B53 (502)
R212	7010004370	Resistor R20J 22 kΩ
R213	7010003640	Resistor ELR20J 68 kΩ
R214	7010003630	Resistor ELR20J 56 kΩ
R215	7310003160	Trimmer EVN-2ACA00 B13 (102)
R216	7310003180	Trimmer EVN-2ACA00 B24 (203)
R217	7010001230	Resistor R25XJ 4.7 kΩ
R218	7010003480	Resistor ELR20J 4.7 kΩ
R219	7010004190	Resistor R20J 1 kΩ
R220	7010001030	Resistor R25XJ 100 Ω
R221	7010003440	Resistor ELR20J 2.2 kΩ
R222	7010004210	Resistor R20J 1.5 kΩ

[MAIN UNIT]

REF. NO.	ORDER NO.	DESCRIPTION
R223	7010004070	Resistor R20J 100 Ω
R224	7010004320	Resistor R20J 10 kΩ
R225	7010004190	Resistor R20J 1 kΩ
R226	7010001030	Resistor R25XJ 100 Ω
R227	7010003440	Resistor ELR20J 2.2 kΩ
R228	7010004210	Resistor R20J 1.5 kΩ
R229	7010003650	Resistor ELR20J 82 kΩ
R230	7010003530	Resistor ELR20J 10 kΩ
R231	7010003280	Resistor ELR20J 100 Ω
R232	7010004230	Resistor R20J 2.2 kΩ
R233	7010003660	Resistor ELR20J 100 kΩ
R234	7010003620	Resistor ELR20J 47 kΩ
R235	7010004230	Resistor R20J 2.2 kΩ
R236	7010003580	Resistor ELR20J 22 kΩ
R237	7010003530	Resistor ELR20J 10 kΩ
R238	7010004370	Resistor R20J 22 kΩ
R239	7010004270	Resistor R20J 4.7 kΩ
R240	7010004270	Resistor R20J 4.7 kΩ
R241	7010004230	Resistor R20J 2.2 kΩ
R242	7010004150	Resistor R20J 470 Ω
R243	7010003470	Resistor ELR20J 3.9 kΩ
R244	7010003300	Resistor ELR20J 150 Ω
R245	7010004070	Resistor R20J 100 Ω
R246	7010003580	Resistor ELR20J 22 kΩ
R247	7310003180	Trimmer EVN-2ACA00 B24 (203)
R248	7510000071	Thermistor ERT-D2ZHL503S
R249	7010003530	Resistor ELR20J 10 kΩ
R250	7010004320	Resistor R20J 10 kΩ
R251	7010003280	Resistor ELR20J 100 Ω
R252	7010003460	Resistor ELR20J 3.3 kΩ
R253	7010003420	Resistor ELR20J 1.5 kΩ
R254	7010001300	Resistor R25XJ 15 kΩ
R255	7010003530	Resistor ELR20J 10 kΩ
R256	7310003220	Trimmer EVN-2ACA00 B16 (105)
R257	7310003220	Trimmer EVN-2ACA00 B16 (105)
R258	7010004320	Resistor R20J 10 kΩ
R259	7010001280	Resistor R25XJ 10 kΩ
R260	7310003200	Trimmer EVN-2ACA00 B14 (103)
R261	7010003440	Resistor ELR20J 2.2 kΩ
R262	7010003740	Resistor ELR20J 470 kΩ
R263	7010001490	Resistor R25XJ 470 kΩ
R264	7010003530	Resistor ELR20J 10 kΩ
R265	7010003310	Resistor ELR20J 180 Ω
R266	7510000300	Thermistor ERT-D2ZGL601S
R267	7010003320	Resistor ELR20J 220 Ω
R268	7010003530	Resistor ELR20J 10 kΩ
R269	7010004320	Resistor R20J 10 kΩ
R270	7010003530	Resistor ELR20J 10 kΩ
R271	7010004410	Resistor R20J 47 kΩ
R272	7010003620	Resistor ELR20J 47 kΩ
R273	7010003620	Resistor ELR20J 47 kΩ
R274	7010003580	Resistor ELR20J 22 kΩ
R275	7010004230	Resistor R20J 2.2 kΩ
R276	7010003530	Resistor ELR20J 10 kΩ
R277	7010003660	Resistor ELR20J 100 kΩ
R278	7010003400	Resistor ELR20J 1 kΩ
R279	7010003660	Resistor ELR20J 100 kΩ
R282	7010003440	Resistor ELR20J 2.2 kΩ
R283	7010003530	Resistor ELR20J 10 kΩ
R284	7010003360	Resistor ELR20J 470 Ω
R285	7010004230	Resistor R20J 2.2 kΩ
R286	7010003660	Resistor ELR20J 100 kΩ
R287	7010003600	Resistor ELR20J 33 kΩ
R288	7010003240	Resistor ELR20J 47 Ω
R289	7010003680	Resistor ELR20J 150 kΩ
R290	7010004490	Resistor R20J 220 kΩ
R291	7010004450	Resistor R20J 100 kΩ
R292	7310003210	Trimmer EVN-2ACA00 B54 (503)
R293	7010004410	Resistor R20J 47 kΩ
R294	7010004410	Resistor R20J 47 kΩ
R295	7010003440	Resistor ELR20J 2.2 kΩ
R296	7010003530	Resistor ELR20J 10 kΩ
R297	7010003660	Resistor ELR20J 100 kΩ
R298	7010003660	Resistor ELR20J 100 kΩ
R299	7010003400	Resistor ELR20J 1 kΩ
R300	7010003440	Resistor ELR20J 2.2 kΩ
R301	7010003400	Resistor ELR20J 1 kΩ
R302	7010003530	Resistor ELR20J 10 kΩ

[MAIN UNIT]

REF. NO.	ORDER NO.	DESCRIPTION
R303	7010003660	Resistor ELR20J 100 kΩ
R304	7010003600	Resistor ELR20J 33 kΩ
R305	7010003220	Resistor ELR20J 33 Ω
R306	7010003360	Resistor ELR20J 470 Ω
R307	7010004230	Resistor R20J 2.2 kΩ
R308	7010004230	Resistor R20J 2.2 kΩ
R309	7010003680	Resistor ELR20J 150 kΩ
R310	7310003210	Trimmer EVN-2ACA00 B54 (503)
R311	7010004370	Resistor R20J 22 kΩ
R312	7010003290	Resistor ELR20J 120 Ω
R313	7010004080	Resistor R20J 120 Ω
R314	7010001190	Resistor R25XJ 2.2 kΩ
R315	7010003240	Resistor ELR20J 47 Ω
R316	7010003240	Resistor ELR20J 47 Ω
R317	7010003460	Resistor ELR20J 3.3 kΩ
R318	7010003600	Resistor ELR20J 33 kΩ
R319	7010003530	Resistor ELR20J 10 kΩ
R320	7310003170	Trimmer EVN-2ACA00 B53 (502)
R321	7010003440	Resistor ELR20J 2.2 kΩ
R322	7010003400	Resistor ELR20J 1 kΩ
R323	7010003400	Resistor ELR20J 1 kΩ
R324	7010003510	Resistor ELR20J 6.8 kΩ
R325	7010003280	Resistor ELR20J 100 Ω
R326	7010004370	Resistor R20J 22 kΩ
R327	7010004320	Resistor R20J 10 kΩ
R328	7010004160	Resistor R20J 560 Ω
R329	7010003530	Resistor ELR20J 10 kΩ
R330	7010004320	Resistor R20J 10 kΩ
R331	7010001230	Resistor R25XJ 4.7 kΩ
R332	7010001150	Resistor R25XJ 1 kΩ
R333	7010003990	Resistor R20J 22 Ω
R334	7010003530	Resistor ELR20J 10 kΩ
R335	7010003530	Resistor ELR20J 10 kΩ
R337	7010003490	Resistor ELR20J 5.6 kΩ
R338	7010003460	Resistor ELR20J 3.3 kΩ
R339	7010003530	Resistor ELR20J 10 kΩ
R340	7010003400	Resistor ELR20J 1 kΩ
R341	7010003710	Resistor ELR20J 270 kΩ
R342	7010004150	Resistor R20J 470 Ω
R344	7010001280	Resistor R25XJ 10 kΩ
R345	7010003440	Resistor ELR20J 2.2 kΩ
R346	7010001280	Resistor R25XJ 10 kΩ
R347	7010003440	Resistor ELR20J 2.2 kΩ
R348	7010003660	Resistor ELR20J 100 kΩ
R349	7010003400	Resistor ELR20J 1 kΩ
R350	7010003480	Resistor ELR20J 4.7 kΩ
R351	7010003440	Resistor ELR20J 2.2 kΩ
R353	7010003480	Resistor ELR20J 4.7 kΩ
R354	7010004070	Resistor R20J 100 kΩ
R355	7010003300	Resistor ELR20J 150 Ω
R356	7010003660	Resistor ELR20J 100 kΩ
R357	7010004450	Resistor R20J 100 kΩ
R358	7010004070	Resistor R20J 100 Ω
R359	7010003530	Resistor ELR20J 10 kΩ
R360	7010004280	Resistor R20J 5.6 kΩ
R361	7010003620	Resistor ELR20J 47 kΩ
R362	7010003740	Resistor ELR20J 470 kΩ
R363	7010003360	Resistor ELR20J 470 Ω
R364	7010004070	Resistor R20J 100 Ω
R365	7010004230	Resistor R20J 2.2 kΩ
R366	7010004230	Resistor R20J 2.2 kΩ
R367	7010003320	Resistor ELR20J 220 Ω
R368	7010004030	Resistor R20J 47 Ω
R369	7010003400	Resistor ELR20J 1 kΩ
R370	7010003530	Resistor ELR20J 10 kΩ
R371	7010004250	Resistor R20J 3.3 kΩ
R372	7010004250	Resistor R20J 3.3 kΩ
R373	7010003400	Resistor ELR20J 1 kΩ
R374	7010003410	Resistor ELR20J 1.2 kΩ
R375	7010003440	Resistor ELR20J 2.2 kΩ
R376	7010003620	Resistor ELR20J 47 kΩ
R377	7010003620	Resistor ELR20J 47 kΩ
R378	7310003220	Trimmer EVN-2ACA00 B16 (105)
R379	7010003530	Resistor ELR20J 10 kΩ (IC-970D only)
R380	7310003230	Trimmer EVN-2ACA00 B15 (104) (IC-970D only)
R384	7010003580	Resistor ELR20J 22 kΩ

[MAIN UNIT]

REF. NO.	ORDER NO.	DESCRIPTION	
R386	7010003620	Resistor	ELR20J 47 kΩ
R387	7010003620	Resistor	ELR20J 47 kΩ
R388	7010003620	Resistor	ELR20J 47 kΩ
R389	7010003620	Resistor	ELR20J 47 kΩ
R390	7010003620	Resistor	ELR20J 47 kΩ
R391	7010003620	Resistor	ELR20J 47 kΩ
R392	7010003620	Resistor	ELR20J 47 kΩ
R393	7010003620	Resistor	ELR20J 47 kΩ
R394	7010003280	Resistor	ELR20J 100 Ω
R395	7010003280	Resistor	ELR20J 100 Ω
R396	7010003480	Resistor	ELR20J 4.7 kΩ
R397	7010003480	Resistor	ELR20J 4.7 kΩ
R398	7010003580	Resistor	ELR20J 22 kΩ
R399	7010004570	Resistor	R20J 1 MΩ
R400	7010003530	Resistor	ELR20J 10 kΩ
R401	7010003580	Resistor	ELR20J 22 kΩ
R402	7010003530	Resistor	ELR20J 10 kΩ
R403	7010004370	Resistor	R20J 22 kΩ
R404	7010003780	Resistor	ELR20J 1 MΩ
R405	7010003530	Resistor	ELR20J 10 kΩ
R406	7010003530	Resistor	ELR20J 10 kΩ
R410	7010004420	Resistor	R20J 56 kΩ
R411	7010003470	Resistor	ELR20J 3.9 kΩ
R417	7010003530	Resistor	ELR20J 10 kΩ
R418	7010003590	Resistor	ELR20J 27 kΩ
R419	7010003530	Resistor	ELR20J 10 kΩ
R420	7010003590	Resistor	ELR20J 27 kΩ
R421	7010003480	Resistor	ELR20J 4.7 kΩ
R422	7010003620	Resistor	ELR20J 47 kΩ
R423	7010003480	Resistor	ELR20J 4.7 kΩ
R424	7010003620	Resistor	ELR20J 47 kΩ
R425	7010003580	Resistor	ELR20J 22 kΩ
R426	7010003580	Resistor	ELR20J 22 kΩ
R427	7010003590	Resistor	ELR20J 27 kΩ
R428	7510000130	Thermistor	ERT-D2FHL333S
R429	7010003580	Resistor	ELR20J 22 kΩ
R430	7010003440	Resistor	ELR20J 2.2 kΩ
R431	7010004200	Resistor	R20J 1.2 kΩ
R432	7010003580	Resistor	ELR20J 22 kΩ
C1	4010000520	Ceramic	DD108 B 472K 50V
C2	4010000520	Ceramic	DD108 B 472K 50V
C3	4010000520	Ceramic	DD108 B 472K 50V
C4	4010000520	Ceramic	DD108 B 472K 50V
C5	4510003860	Electrolytic	50 MV 3R3 SW
C6	4310000020	Mylar	F2D 50V 103K
C7	4010000520	Ceramic	DD108 B 472K 50V
C8	4010000520	Ceramic	DD108 B 472K 50V
C9	4010000180	Ceramic	DD104 SL 220J 50V
C10	4040000150	Barrier Layer	UAT 05X 472K
C11	4040000150	Barrier Layer	UAT 05X 472K
C12	4010000520	Ceramic	DD108 B 472K 50V
C13	4010000520	Ceramic	DD108 B 472K 50V
C14	4010000520	Ceramic	DD108 B 472K 50V
C15	4040000150	Barrier Layer	UAT 05X 472K
C16	4040000150	Barrier Layer	UAT 05X 472K
C17	4010000520	Ceramic	DD108 B 472K 50V
C18	4510003820	Electrolytic	50 MV R22 SW
C19	4510003790	Electrolytic	16 MV 10 SW
C20	4510003790	Electrolytic	16 MV 10 SW
C21	4510003790	Electrolytic	16 MV 10 SW
C22	4510003830	Electrolytic	50 MV R47 SW
C23	4010000040	Ceramic	DD104 SL 020C 50V
C24	4510003790	Electrolytic	16 MV 10 SW
C25	4010000520	Ceramic	DD108 B 472K 50V
C26	4040000150	Barrier Layer	UAT 05X 472K
C27	4040000150	Barrier Layer	UAT 05X 472K
C28	4510003790	Electrolytic	16 MV 10 SW
C29	4010000520	Ceramic	DD108 B 472K 50V
C30	4040000150	Barrier Layer	UAT 05X 472K
C31	4010000520	Ceramic	DD108 B 472K 50V
C32	4010000340	Ceramic	DD105 SL 121J 50V
C33	4010000180	Ceramic	DD104 SL 220J 50V
C34	4510003800	Electrolytic	25 MV 4R7 SW
C35	4010000520	Ceramic	DD108 B 472K 50V
C36	4010000330	Ceramic	DD105 SL 101J 50V
C37	4510003790	Electrolytic	16 MV 10 SW

[MAIN UNIT]

REF. NO.	ORDER NO.	DESCRIPTION	
C38	4010000520	Ceramic	DD108 B 472K 50V
C39	4040000150	Barrier Layer	UAT 05X 472K
C40	4040000260	Barrier Layer	UZE 08X 104M
C41	4010000520	Ceramic	DD108 B 472K 50V
C42	4010000370	Ceramic	DD108 SL 201J 50V
C43	4010000940	Ceramic	DD107 CH 101J 50V
C44	4010000520	Ceramic	DD108 B 472K 50V
C45	4010000520	Ceramic	DD108 B 472K 50V
C46	4510003790	Electrolytic	16 MV 10 SW
C47	4510004180	Electrolytic	50 MV R33 SW
C48	4510003790	Electrolytic	16 MV 10 SW
C49	4510003790	Electrolytic	16 MV 10 SW
C50	4510003790	Electrolytic	16 MV 10 SW
C52	4010000520	Ceramic	DD108 B 472K 50V
C53	4010000520	Ceramic	DD108 B 472K 50V
C54	4010000520	Ceramic	DD108 B 472K 50V
C57	4010000050	Ceramic	DD104 SL 030C 50V
C58	4040000260	Barrier Layer	UZE 08X 104M
C59	4010000520	Ceramic	DD108 B 472K 50V
C60	4040000260	Barrier Layer	UZE 08X 104M
C61	4010000520	Ceramic	DD108 B 472K 50V
C62	4040000260	Barrier Layer	UZE 08X 104M
C63	4010000200	Ceramic	DD104 SL 270J 50V
C64	4010000520	Ceramic	DD108 B 472K 50V
C65	4510003790	Electrolytic	16 MV 10 SW
C66	4010000520	Ceramic	DD108 B 472K 50V
C67	4010000520	Ceramic	DD108 B 472K 50V
C68	4010000260	Ceramic	DD104 SL 470J 50V
C69	4040000150	Barrier Layer	UAT 05X 472K
C70	4010000520	Ceramic	DD108 B 472K 50V
C71	4510003840	Electrolytic	50 MV 1 SW
C72	4010000520	Ceramic	DD108 B 472K 50V
C73	4010000260	Ceramic	DD104 SL 470J 50V
C74	4010000980	Ceramic	DD109 CH 151J 50V
C75	4010000980	Ceramic	DD109 CH 151J 50V
C76	4610000130	Trimmer	CV05E3001
C77	4010000820	Ceramic	DD105 CH 330J 50V
C78	4040000150	Barrier Layer	UAT 05X 472K
C79	4010000520	Ceramic	DD108 B 472K 50V
C80	4010000520	Ceramic	DD108 B 472K 50V
C81	4010000520	Ceramic	DD108 B 472K 50V
C82	4550000350	Tantalum	DN 1V 010M
C83	4550000350	Tantalum	DN 1V 010M
C84	4550000360	Tantalum	DN 1V R47M
C85	4010000500	Ceramic	DD104 B 102K 50V
C86	4010000500	Ceramic	DD104 B 102K 50V
C87	4510003800	Electrolytic	25 MV 4R7 SW
C88	4010003600	Ceramic	DD107 UJ 121J 50V
C90	4040000260	Barrier Layer	UZE 08X 104M
C91	4510003790	Electrolytic	16 MV 10 SW
C92	4040000260	Barrier Layer	UZE 08X 104M
C93	4040000260	Barrier Layer	UZE 08X 104M
C94	4010000180	Ceramic	DD104 SL 220J 50V
C95	4010000520	Ceramic	DD108 B 472K 50V
C96	4010000500	Ceramic	DD104 B 102K 50V
C97	4040000190	Barrier Layer	UAT 05X 103K
C98	4010000460	Ceramic	DD104 B 471K 50V
C99	4010000460	Ceramic	DD104 B 471K 50V
C100	4010000220	Ceramic	DD104 SL 330J 50V
C101	4040000190	Barrier Layer	UAT 05X 103K
C102	4550000010	Tantalum	DN 1C 4R7M
C103	4010000850	Ceramic	DD104 CH 050C 50V
C104	4010000520	Ceramic	DD108 B 472K 50V
C105	4040000250	Barrier Layer	UAT 08X 473M
C106	4010004870	Ceramic	DD304 F 473Z 25V
C107	4040000250	Barrier Layer	UAT 08X 473M
C108	4040000250	Barrier Layer	UAT 08X 473M
C109	4010000500	Ceramic	DD104 B 102K 50V
C110	4510003800	Electrolytic	25 MV 4R7 SW
C111	4510003790	Electrolytic	16 MV 10 SW
C112	4010003340	Ceramic	DD104 UJ 100D 50V
C113	4010000520	Ceramic	DD108 B 472K 50V
C114	4010000520	Ceramic	DD108 B 472K 50V
C115	4010000520	Ceramic	DD108 B 472K 50V
C116	4040000240	Barrier Layer	UAT 08X 333M
C117	4010000520	Ceramic	DD108 B 472K 50V
C118	4510003830	Electrolytic	50 MV R47 SW
C119	4310000110	Mylar	F2D 50V 472K

[MAIN UNIT]

REF. NO.	ORDER NO.	DESCRIPTION
C120	4010000520	Ceramic DD108 B 472K 50V
C121	4040000150	Barrier Layer UAT 05X 472K
C122	4040000150	Barrier Layer UAT 05X 472K
C123	4010000520	Ceramic DD108 B 472K 50V
C124	4010000520	Ceramic DD108 B 472K 50V
C125	4010000350	Ceramic DD108 SL 151J 50V
C126	4020000620	Cylinder UP050 SL 220J
C127	4010000520	Ceramic DD108 B 472K 50V
C128	4010000520	Ceramic DD108 B 472K 50V
C129	4040000250	Barrier Layer UAT 08X 473M
C130	4550000320	Tantalum DN 1V 0R1M
C131	4010000520	Ceramic DD108 B 472K 50V
C132	4510003850	Electrolytic 50 MV 2R2 SW
C133	4040000150	Barrier Layer UAT 05X 472K
C134	4510001770	Electrolytic 16 RBP 10 μ F
C135	4510003830	Electrolytic 50 MV R47 SW
C136	4510003830	Electrolytic 50 MV R47 SW
C137	4010004840	Ceramic DD305 F 104Z 12V
C138	4040000090	Barrier Layer UAT 04X 152K
C139	4040000090	Barrier Layer UAT 04X 152K
C140	4040000090	Barrier Layer UAT 04X 152K
C141	4510003810	Electrolytic 50 MV R1 SW
C142	4310000420	Mylar F2D 50V 333J
C143	4310000420	Mylar F2D 50V 333J
C144	4010004840	Ceramic DD305 F 104Z 12V
C145	4040000090	Barrier Layer UAT 04X 152K
C146	4040000090	Barrier Layer UAT 04X 152K
C147	4040000090	Barrier Layer UAT 04X 152K
C148	4510003810	Electrolytic 50 MV R1 SW
C149	4510003790	Electrolytic 16 MV 10 SW
C150	4010001010	Ceramic DD110 CH 201J 50V
C151	4010000920	Ceramic DD107 CH 820J 50V
C152	4040000260	Barrier Layer UZE 08X 104M
C153	4510003790	Electrolytic 16 MV 10 SW
C154	4040000260	Barrier Layer UZE 08X 104M
C155	4010000320	Ceramic DD104 SL 820J 50V
C156	4040000260	Barrier Layer UZE 08X 104M
C157	4010000180	Ceramic DD104 SL 220J 50V
C158	4040000150	Barrier Layer UAT 05X 472K
C159	4010000340	Ceramic DD105 SL 121J 50V
C160	4010000520	Ceramic DD108 B 472K 50V
C161	4040000190	Barrier Layer UAT 05X 103K
C162	4010000460	Ceramic DD104 B 471K 50V
C163	4010000460	Ceramic DD104 B 471K 50V
C164	4010000220	Ceramic DD104 SL 330J 50V
C165	4040000190	Barrier Layer UAT 05X 103K
C166	4550000010	Tantalum DN 1C 4R7M
C167	4040000250	Barrier Layer UAT 08X 473M
C168	4040000250	Barrier Layer UAT 08X 473M
C169	4040000250	Barrier Layer UAT 08X 473M
C170	4040000250	Barrier Layer UAT 08X 473M
C171	4010000500	Ceramic DD104 B 102K 50V
C172	4510003800	Electrolytic 25 MV 4R7 SW
C173	4020000670	Cylinder UP050 SL 470J
C174	4010000520	Ceramic DD108 B 472K 50V
C175	4010000520	Ceramic DD108 B 472K 50V
C176	4010000520	Ceramic DD108 B 472K 50V
C177	4010000520	Ceramic DD108 B 472K 50V
C178	4010000520	Ceramic DD108 B 472K 50V
C179	4010000520	Ceramic DD108 B 472K 50V
C180	4010000520	Ceramic DD108 B 472K 50V
C181	4040000150	Barrier Layer UAT 05X 472K
C182	4010000520	Ceramic DD108 B 472K 50V
C183	4010000520	Ceramic DD108 B 472K 50V
C184	4010000260	Ceramic DD104 SL 470J 50V
C185	4010000980	Ceramic DD109 CH 151J 50V
C186	4010000980	Ceramic DD109 CH 151J 50V
C187	4610000130	Trimmer CV05E3001
C188	4010000820	Ceramic DD105 CH 330J 50V
C189	4040000150	Barrier Layer UAT 05X 472K
C190	4010000520	Ceramic DD108 B 472K 50V
C191	4010000520	Ceramic DD108 B 472K 50V
C192	4510003860	Electrolytic 50 MV 3R3 SW
C193	4010000520	Ceramic DD108 B 472K 50V
C194	4310000110	Mylar F2D 50V 472K
C195	4010000520	Ceramic DD108 B 472K 50V
C196	4040000150	Barrier Layer UAT 05X 472K
C197	4040000150	Barrier Layer UAT 05X 472K

[MAIN UNIT]

REF. NO.	ORDER NO.	DESCRIPTION
C198	4010000520	Ceramic DD108 B 472K 50V
C199	4010000520	Ceramic DD108 B 472K 50V
C200	4010000350	Ceramic DD108 SL 151J 50V
C201	4020000620	Cylinder UP050 SL 220J
C202	4010000520	Ceramic DD108 B 472K 50V
C203	4010000520	Ceramic DD108 B 472K 50V
C204	4040000250	Barrier Layer UAT 08X 473M
C205	4510003810	Electrolytic 50 MV R1 SW
C206	4510003850	Electrolytic 50 MV 2R2 SW
C207	4010000520	Ceramic DD108 B 472K 50V
C212	4010004840	Ceramic DD305 F 104Z 12V
C213	4040000150	Barrier Layer UAT 05X 472K
C214	4010000520	Ceramic DD108 B 472K 50V
C215	4010000520	Ceramic DD108 B 472K 50V
C216	4510001770	Electrolytic 16 RBP 10 μ F
C217	4510003820	Electrolytic 50 MV R22 SW
C218	4510003800	Electrolytic 25 MV 4R7 SW
C219	4510003790	Electrolytic 16 MV 10 SW
C220	4040000260	Barrier Layer UZE 08X 104M
C221	4040000260	Barrier Layer UZE 08X 104M
C222	4510003810	Electrolytic 50 MV R1 SW
C223	4010000520	Ceramic DD108 B 472K 50V
C224	4510003820	Electrolytic 50 MV R22 SW
C225	4010004840	Ceramic DD305 F 104Z 12V
C226	4510003800	Electrolytic 25 MV 4R7 SW
C227	4510003790	Electrolytic 16 MV 10 SW
C228	4040000260	Barrier Layer UZE 08X 104M
C229	4510003810	Electrolytic 50 MV R1 SW
C230	4040000260	Barrier Layer UZE 08X 104M
C231	4040000240	Barrier Layer UAT 08X 333M
C232	4510003900	Electrolytic 16 MV 22 HW
C233	4510003830	Electrolytic 50 MV R47 SW
C234	4510003830	Electrolytic 50 MV R47 SW
C235	4510003800	Electrolytic 25 MV 4R7 SW
C236	4510003920	Electrolytic 16 MV 100 HW
C237	4510003800	Electrolytic 25 MV 4R7 SW
C238	4510004120	Electrolytic 16 MV 330 HW
C239	4510003930	Electrolytic 16 MV 470 HW
C240	4510003920	Electrolytic 16 MV 100 HW
C241	4510003930	Electrolytic 16 MV 470 HW
C242	4310000500	Mylar F2D 50V 154J
C243	4510003920	Electrolytic 16 MV 100 HW
C244	4310000500	Mylar F2D 50V 154J
C245	4510003930	Electrolytic 16 MV 470 HW
C246	4040000260	Barrier Layer UZE 08X 104M
C247	4510003920	Electrolytic 16 MV 100 HW
C248	4510003790	Electrolytic 16 MV 10 SW
C249	4550000350	Tantalum DN 1V 010M
C250	4510004370	Electrolytic 16 MST 47 μ F (5X7)
C251	4550000310	Tantalum DN 1V 2R2M
C252	4550000340	Tantalum DN 1C 100M
C253	4510003790	Electrolytic 16 MV 10 SW
C254	4310000010	Mylar F2D 50V 102K
C255	4010000520	Ceramic DD108 B 472K 50V
C256	4040000260	Barrier Layer UZE 08X 104M
C257	4040000240	Barrier Layer UAT 08X 333M
C258	4010000520	Ceramic DD108 B 472K 50V
C259	4010000150	Ceramic DD104 SL 150J 50V
C260	4010000150	Ceramic DD104 SL 150J 50V
C261	4010000110	Ceramic DD104 SL 090D 50V
C262	4010000520	Ceramic DD108 B 472K 50V
C263	4510004010	Electrolytic 10 MV 470 HW
C264	4040000150	Barrier Layer UAT 05X 472K
C265	4040000150	Barrier Layer UAT 05X 472K
C266	4010000520	Ceramic DD108 B 472K 50V
C267	4010002050	Ceramic DD104 RH 180J 50V
C268	4010000520	Ceramic DD108 B 472K 50V
C269	4010000980	Ceramic DD109 CH 151J 50V
C270	4010000980	Ceramic DD109 CH 151J 50V
C271	4010000060	Ceramic DD104 SL 040C 50V
C272	4010000520	Ceramic DD108 B 472K 50V
C273	4010000340	Ceramic DD105 SL 121J 50V
C274	4010000520	Ceramic DD108 B 472K 50V
C275	4010000520	Ceramic DD108 B 472K 50V
C276	4010000520	Ceramic DD108 B 472K 50V
C277	4010000520	Ceramic DD108 B 472K 50V
C278	4010000520	Ceramic DD108 B 472K 50V
C280	4040000150	Barrier Layer UAT 05X 472K

[MAIN UNIT]

REF. NO.	ORDER NO.	DESCRIPTION	
C281	4010000520	Ceramic	DD108 B 472K 50V
C282	4550002880	Tantalum	DN 1V 0R1K
C283	4510003980	Electrolytic	10 MV 100 HWS (5X11)
C284	4510003980	Electrolytic	10 MV 100 HWS (5X11)
C285	4510003910	Electrolytic	16 MV 47 HW
C286	4510003910	Electrolytic	16 MV 47 HW
C287	4040000150	Barrier Layer	UAT 05X 472K
C288	4010000520	Ceramic	DD108 B 472K 50V
C289	4010000520	Ceramic	DD108 B 472K 50V
C290	4010000500	Ceramic	DD104 B 102K 50V
C292	4510003860	Electrolytic	50 MV 3R3 SW
C293	4510003790	Electrolytic	16 MV 10 SW
C294	4010004840	Ceramic	DD305 F 104Z 12V
C295	4040000260	Barrier Layer	UZE 08X 104M
C296	4040000260	Barrier Layer	UZE 08X 104M
C297	4040000260	Barrier Layer	UZE 08X 104M
C298	4040000260	Barrier Layer	UZE 08X 104M
C299	4040000190	Barrier Layer	UAT 05X 103K
C300	4040000250	Barrier Layer	UAT 08X 473M
C301	4040000250	Barrier Layer	UAT 08X 473M
C302	4020000330	Cylinder	UP125 SL 180J
C303	4010004840	Ceramic	DD305 F 104Z 12V
C304	4040000190	Barrier Layer	UAT 05X 103K
C305	4040000250	Barrier Layer	UAT 08X 473M
C306	4010004870	Ceramic	DD304 F 473Z 25V
C307	4010000160	Ceramic	DD104 SL 180J 50V
C308	4010004870	Ceramic	DD304 F 473Z 25V
C309	4040000150	Barrier Layer	UAT 05X 472K
C310	4040000150	Barrier Layer	UAT 05X 472K
C311	4510003790	Electrolytic	16 MV 10 SW
C312	4040000150	Barrier Layer	UAT 05X 472K
C313	4010000520	Ceramic	DD108 B 472K 50V
C314	4010000520	Ceramic	DD108 B 472K 50V
C315	4010000340	Ceramic	DD105 SL 121J 50V
C316	4010000040	Ceramic	DD104 SL 020C 50V
C317	4010000180	Ceramic	DD104 SL 220J 50V
C318	4510003800	Electrolytic	25 MV 4R7 SW
C319	4010000520	Ceramic	DD108 B 472K 50V
C320	4040000260	Barrier Layer	UZE 08X 104M
C321	4010000060	Ceramic	DD104 SL 040C 50V
C322	4010000060	Ceramic	DD104 SL 040C 50V
C323	4010000050	Ceramic	DD104 SL 030C 50V
C324	4040000260	Barrier Layer	UZE 08X 104M
C325	4040000150	Barrier Layer	UAT 05X 472K
C326	4040000090	Barrier Layer	UAT 04X 152K
C327	4550000350	Tantalum	DN 1V 010M
C328	4550000350	Tantalum	DN 1V 010M
C329	4510003910	Electrolytic	16 MV 47 HW
C330	4040000190	Barrier Layer	UAT 05X 103K
C331	4040000190	Barrier Layer	UAT 05X 103K
C332	4550000410	Tantalum	DN 1V 4R7M
C333	4510003790	Electrolytic	16 MV 10 SW
C334	4010000210	Ceramic	DD104 SL 300J 50V
C335	4010000900	Ceramic	DD107 CH 680J 50V
C336	4010000500	Ceramic	DD104 B 102K 50V
C337	4010000500	Ceramic	DD104 B 102K 50V
C338	4010000500	Ceramic	DD104 B 102K 50V
C339	4010000500	Ceramic	DD104 B 102K 50V
C340	4010000070	Ceramic	DD104 SL 050C 50V
EP1	0910023875	P.C. Board	B 2275E (MAIN)

[MS-A UNIT]

REF. NO.	ORDER NO.	DESCRIPTION	
IC1	1110000960	IC	NJM4558M(T1)
Q1	1530000160	Transistor	2SC2712-Y (TE85RT EM)
D1	1790000590	Diode	MA110(TW)
D2	1790000450	Diode	MA862(TX)
D3	1790000590	Diode	MA110(TW)
D4	1790000490	Diode	HSM88AS-TR
R1	7030000560	Resistor	MCR10EZHZ 33 kΩ (333)
R2	7030000530	Resistor	MCR10EZHZ 18 kΩ (183)
R3	7030000700	Resistor	MCR10EZHZ 470 kΩ (474)
R4	7030000500	Resistor	MCR10EZHZ 10 kΩ (103)
R5	7030000570	Resistor	MCR10EZHZ 39 kΩ (393)
R6	7030000540	Resistor	MCR10EZHZ 22 kΩ (223)
R7	7030000970	Resistor	MCR10EZHZ 2.2 MΩ (225)
R8	7030001560	Resistor	MCR10EZHZ 1.5 MΩ (155)
R9	7030000700	Resistor	MCR10EZHZ 470 kΩ (474)
R10	7030000970	Resistor	MCR10EZHZ 2.2 MΩ (225)
R11	7030000380	Resistor	MCR10EZHZ 1 kΩ (102)
R12	7030000540	Resistor	MCR10EZHZ 22 kΩ (223)
C1	4030004720	Ceramic	C2012 JB 1H 102K- T-A
C3	4550002720	Tantalum	TESVD2 0J 476M-12 L
C4	4030004630	Ceramic	C2012 SL 1H 151J- T-A
EP1	6910002720	Lead Frame	HFB2.54-0.9-8 (N)
EP2	0910023583	P.C. Board	B 2268C (MS-A)

[MS-B UNIT]

REF. NO.	ORDER NO.	DESCRIPTION	
IC1	1110000960	IC	NJM4558M(T1)
R1	7030000600	Resistor	MCR10EZHZ 68 kΩ (683)
R2	7030000600	Resistor	MCR10EZHZ 68 kΩ (683)
R3	7030000600	Resistor	MCR10EZHZ 68 kΩ (683)
R4	7030000500	Resistor	MCR10EZHZ 10 kΩ (103)
R5	7030000420	Resistor	MCR10EZHZ 2.2 kΩ (222)
R6	7030000700	Resistor	MCR10EZHZ 470 kΩ (474)
R7	7030000380	Resistor	MCR10EZHZ 1 kΩ (102)
R8	7030000380	Resistor	MCR10EZHZ 1 kΩ (102)
R9	7030000530	Resistor	MCR10EZHZ 18 kΩ (183)
R10	7030000380	Resistor	MCR10EZHZ 1 kΩ (102)
R11	7030000390	Resistor	MCR10EZHZ 1.2 kΩ (122)
C1	4030004620	Ceramic	C2012 SL 1H 121J- T-A
C2	4030004730	Ceramic	C2012 JB 1H 222K- T-A
C3	4030004720	Ceramic	C2012 JB 1H 102K- T-A
C4	4030004730	Ceramic	C2012 JB 1H 222K- T-A
EP1	6910002720	Lead Frame	HFB2.54-0.9-8 (N)
EP2	0910023593	P.C. Board	B 2269C (MS-B)

[MS-C UNIT]

REF. NO.	ORDER NO.	DESCRIPTION	
IC1	1110000960	IC	NJM4558M(T1)
D1	1790000590	Diode	MA110(TW)
R1	7030000340	Resistor	MCR10EZHZ 470 Ω (471)
R2	7030000970	Resistor	MCR10EZHZ 2.2 MΩ (225)
R3	7030000700	Resistor	MCR10EZHZ 470 kΩ (474)
R4	7030000460	Resistor	MCR10EZHZ 4.7 kΩ (472)
R5	7030000500	Resistor	MCR10EZHZ 10 kΩ (103)
R7	7030000740	Resistor	MCR10EZHZ 1 MΩ (105)
R8	7030000970	Resistor	MCR10EZHZ 2.2 MΩ (225)
R9	7030000740	Resistor	MCR10EZHZ 1 MΩ (105)
C1	4030004720	Ceramic	C2012 JB 1H 102K- T-A
C2	4030004760	Ceramic	C2012 JF 1E 104Z- T-A
C3	4030004740	Ceramic	C2012 JB 1H 472K- T-A
C4	4030004720	Ceramic	C2012 JB 1H 102K- T-A
C5	4030004420	Ceramic	C2012 SL 1H 050C- T-A
EP1	6910002720	Lead Frame	HFB2.54-0.9-8 (N)
EP2	0910023603	P.C. Board	B 2270C (MS-C)

[MS-D UNIT]

REF. NO.	ORDER NO.	DESCRIPTION	
IC1	1110000960	IC	NJM4558M(T1)
D1	1790000590	Diode	MA110(TW)
R5	7030000540	Resistor	MCR10EZHZ 22 kΩ (223)
R6	7030000740	Resistor	MCR10EZHZ 1 MΩ (105)
R7	7030000740	Resistor	MCR10EZHZ 1 MΩ (105)
R8	7030000740	Resistor	MCR10EZHZ 1 MΩ (105)
R9	7030000740	Resistor	MCR10EZHZ 1 MΩ (105)
C3	4030004720	Ceramic	C2012 JB 1H 102K- T-A
EP1	6910002720	Lead Frame	HFB2.54-0.9-8 (N)
EP2	0910023613	P.C. Board	B 2271C (MS-D)

[MS-E UNIT]

REF. NO.	ORDER NO.	DESCRIPTION	
IC1	1110000960	IC	NJM4558M(T1)
R2	7030000970	Resistor	MCR10EZHZ 2.2 MΩ (225)
R3	7030000500	Resistor	MCR10EZHZ 10 kΩ (103)
R4	7030000500	Resistor	MCR10EZHZ 10 kΩ (103)
R5	7030000500	Resistor	MCR10EZHZ 10 kΩ (103)
R6	7030000500	Resistor	MCR10EZHZ 10 kΩ (103)
R7	7030000620	Resistor	MCR10EZHZ 100 kΩ (104)
R8	7030000620	Resistor	MCR10EZHZ 100 kΩ (104)
R9	7030000970	Resistor	MCR10EZHZ 2.2 MΩ (225)
R10	7030000970	Resistor	MCR10EZHZ 2.2 MΩ (225)
R11	7030000500	Resistor	MCR10EZHZ 10 kΩ (103)

[MS-E UNIT]

REF. NO.	ORDER NO.	DESCRIPTION	
R14	7030000970	Resistor	MCR10EZHZ 2.2 MΩ (225)
C1	4030004720	Ceramic	C2012 JB 1H 102K- T-A
C2	4030003320	Ceramic	GRM40 F 333Z 50PT
C3	4030003320	Ceramic	GRM40 F 333Z 50PT
C4	4030004760	Ceramic	C2012 JF 1E 104Z- T-A
C5	4030003590	Ceramic	GRM40 B 152K 50PT
C6	4030003590	Ceramic	GRM40 B 152K 50PT
C7	4030003590	Ceramic	GRM40 B 152K 50PT
C8	4030004760	Ceramic	C2012 JF 1E 104Z- T-A
EP1	6910002720	Lead Frame	HFB2.54-0.9-8 (N)
EP2	0910023624	P.C. Board	B 2272D (MS-E)

[MS-F UNIT]

REF. NO.	ORDER NO.	DESCRIPTION	
IC1	1130001910	IC	μ PD4011BG-T1
IC2	1130001250	IC	μ PD4066BG-T1
D1	1790000590	Diode	MA110(TW)
D2	1790000590	Diode	MA110(TW)
D3	1790000590	Diode	MA110(TW)
D4	1790000590	Diode	MA110(TW)
R1	7030000580	Resistor	MCR10EZHZ 47 kΩ (473)
R2	7030000580	Resistor	MCR10EZHZ 47 kΩ (473)
R3	7030000580	Resistor	MCR10EZHZ 47 kΩ (473)
R4	7030000420	Resistor	MCR10EZHZ 2.2 kΩ (222)
R6	7030000580	Resistor	MCR10EZHZ 47 kΩ (473)
R7	7030000580	Resistor	MCR10EZHZ 47 kΩ (473)
R8	7030000460	Resistor	MCR10EZHZ 4.7 kΩ (472)
R9	7030000460	Resistor	MCR10EZHZ 4.7 kΩ (472)
EP1	6910002720	Lead Frame	HFB2.54-0.9-8 (N)
EP2	0910023634	P.C. Board	B 2273D (MS-F)

[MS-G UNIT]

REF. NO.	ORDER NO.	DESCRIPTION	
IC1	1130001910	IC	μ PD4011BG-T1
Q1	1530000160	Transistor	2SC2712-Y (TE85RT EM)
Q2	1530000160	Transistor	2SC2712-Y (TE85RT EM)
Q3	1590000400	FET	UN2114(TW)
Q4	1540000250	Transistor	2SD999-T2 CK
D1	1790000590	Diode	MA110(TW)
D2	1790000590	Diode	MA110(TW)
D3	1790000590	Diode	MA110(TW)
D4	1790000590	Diode	MA110(TW)
D5	1790000590	Diode	MA110(TW)
D6	1790000590	Diode	MA110(TW)
D7	1790000590	Diode	MA110(TW)
R1	7030000500	Resistor	MCR10EZHZ 10 kΩ (103)

[MS-G UNIT]

REF. NO.	ORDER NO.	DESCRIPTION	
R2	7030000500	Resistor	MCR10EZHZ 10 kΩ (103)
R3	7030000700	Resistor	MCR10EZHZ 470 kΩ (474)
R4	7030000700	Resistor	MCR10EZHZ 470 kΩ (474)
R5	7030000380	Resistor	MCR10EZHZ 1 kΩ (102)
R6	7030000500	Resistor	MCR10EZHZ 10 kΩ (103)
R7	7030000500	Resistor	MCR10EZHZ 10 kΩ (103)
C1	4030003340	Ceramic	GRM40 B 332K 50PT
C2	4030003360	Ceramic	GRM40 F 473Z 50PT
EP1	6910002720	Lead Frame	HFB2.54-0.9-8 (N)
EP2	0910023644	P.C. Board	B 2274D (MS-G)

[MS-I UNIT]

REF. NO.	ORDER NO.	DESCRIPTION	
R3	7030000700	Resistor	MCR10EZHZ 470 kΩ (474)
R4	7030000500	Resistor	MCR10EZHZ 10 kΩ (103)
R5	7030000570	Resistor	MCR10EZHZ 39 kΩ (393)
R6	7030000540	Resistor	MCR10EZHZ 22 kΩ (223)
R7	7030000970	Resistor	MCR10EZHZ 2.2 MΩ (225)
R8	7030001560	Resistor	MCR10EZHZ 1.5 MΩ (155)
R9	7030000700	Resistor	MCR10EZHZ 470 kΩ (474)
R10	7030000970	Resistor	MCR10EZHZ 2.2 MΩ (225)
R11	7030000380	Resistor	MCR10EZHZ 1 kΩ (102)
R12	7030000540	Resistor	MCR10EZHZ 22 kΩ (223)
C1	4030004720	Ceramic	C2012 JB 1H 102K- T-A
C3	4550002720	Tantalum	TESVD2 0J 476M-12 L
C4	4030004630	Ceramic	C2012 SL 1H 151J- T-A
EP1	6910002720	Lead Frame	HFB2.54-0.9-8 (N)
EP2	0910023583	P.C. Board	B 2268C (MS-I)

[MS-H UNIT]

REF. NO.	ORDER NO.	DESCRIPTION	
IC1	1110000960	IC	NJM4558M(T1)
D1	1790000590	Diode	MA110(TW)
D2	1790000590	Diode	MA110(TW)
R1	7030000700	Resistor	MCR10EZHZ 470 kΩ (474)
R2	7510000220	Thermistor	DTN-T203S332LS(T)
R3	7030000560	Resistor	MCR10EZHZ 33 kΩ (333)
R4	7030000560	Resistor	MCR10EZHZ 33 kΩ (333)
R5	7030000580	Resistor	MCR10EZHZ 47 kΩ (473)
R6	7030000580	Resistor	MCR10EZHZ 47 kΩ (473)
R7	7030000700	Resistor	MCR10EZHZ 470 kΩ (474)
R8	7510000220	Thermistor	DTN-T203S332LS(T)
R9	7030000560	Resistor	MCR10EZHZ 33 kΩ (333)
R10	7030000560	Resistor	MCR10EZHZ 33 kΩ (333)
R11	7030000580	Resistor	MCR10EZHZ 47 kΩ (473)
R12	7030000580	Resistor	MCR10EZHZ 47 kΩ (473)
C1	4030004720	Ceramic	C2012 JB 1H 102K- T-A
C2	4030004720	Ceramic	C2012 JB 1H 102K- T-A
EP1	0910024722	P.C. Board	B 2366B (MS-H)
EP2	6910002720	Lead Frame	HFB2.54-0.9-8 (N)

[FRONT UNIT]

REF. NO.	ORDER NO.	DESCRIPTION	
S1	2230000120	Switch	SDDSA3159A [POWER]
S2	2260000310	Switch	M-2012J [TRANSMIT/RECEIVE]
S3	7600000110	Switch	SW-110 (E C24B50B00190) [RIT(SUB DIAL)]
EP2	6910003560	Lead Frame	JSM5011-01-020
EP12	6910000630	Bead core	FSOH070RN
EP13	6910000630	Bead core	FSOH070RN

[SW(A) UNIT]

REF. NO.	ORDER NO.	DESCRIPTION	
Q1	1590000350	Transistor	RN1204
R1	7010001120	Resistor	R25XJ 560 Ω
R2	7010001120	Resistor	R25XJ 560 Ω
DS1	5040001450	LED	SLB-25VR 5F
DS2	5040001440	LED	SLB-25YY 3F
S1	2230000820	Switch	EVQ-QS2 05K [TONE(1)]
S2	2230000820	Switch	EVQ-QS2 05K [DUP(2)]
S3	2230000820	Switch	EVQ-QS2 05K [CHECK(3)]
S4	2230000820	Switch	EVQ-QS2 05K [P-BEEP(4)]
S5	2230000820	Switch	EVQ-QS2 05K [T-SQL(5)]
S6	2230000820	Switch	EVQ-QS2 05K [SET(6)]
S7	2230000820	Switch	EVQ-QS2 05K [PAGER(7)]
S8	2230000820	Switch	EVQ-QS2 05K [C-SQL(8)]
S9	2230000820	Switch	EVQ-QS2 05K [PITCH(9)]
S10	2230000820	Switch	EVQ-QS2 05K [MHz(+)]
S11	2230000820	Switch	EVQ-QS2 05K [kHz(0)]
S12	2230000820	Switch	EVQ-QS2 05K [BAND(ENT)]
S13	2230000820	Switch	EVQ-QS2 05K [M/S]
S14	2230000820	Switch	EVQ-QS2 05K [SUB]
S15	2230000810	Switch	ESB-64801 [CLICK]
S16	2230000820	Switch	EVQ-QS2 05K [FUNCTION]

[MS-I UNIT]

REF. NO.	ORDER NO.	DESCRIPTION	
IC1	1110000960	IC	NJM4558M(T1)
Q1	1530000180	Transistor	2SC2712-Y (TE85RT EM)
D1	1790000590	Diode	MA110(TW)
D2	1790000450	Diode	MA862(TX)
D3	1790000590	Diode	MA110(TW)
D4	1790000490	Diode	HSM88AS-TR
R1	7030000560	Resistor	MCR10EZHZ 33 kΩ (333)
R2	7030000530	Resistor	MCR10EZHZ 18 kΩ (183)

[SW(A) UNIT]

REF. NO.	ORDER NO.	DESCRIPTION	
S17	2230000820	Switch	EVQ-QS2 05K [SPLIT]
S18	2230000820	Switch	EVQ-QS2 05K [A/B]
S19	2230000820	Switch	EVQ-QS2 05K [A=B]
S20	2230000820	Switch	EVQ-QS2 05K [CALL-1]
S21	2230000820	Switch	EVQ-QS2 05K [CALL-2]
S22	2230000820	Switch	EVQ-QS2 05K [RIT(RIT-CL)]
S23	2230000820	Switch	EVQ-QS2 05K [MEMO(ENT)]
S24	2230000820	Switch	EVQ-QS2 05K [MW(M-CL)]
S25	2230000820	Switch	EVQ-QS2 05K [M→VFO(SKIP)]
S26	2230000810	Switch	ESB-64801 [NOTCH]
EP1	0910023944	P.C. Board	B 2314D (SW(A))

[SW(B) UNIT]

REF. NO.	ORDER NO.	DESCRIPTION	
IC1	1130003900	IC	GD4066B
IC2	1110002020	IC	TA7805S
Q4	1530000591	Transistor	2SC2785 EL
Q5	1590000350	Transistor	RN1204
Q6	1530000591	Transistor	2SC2785 EL
Q7	1510000080	Transistor	2SA1048-GR
Q8	1530000591	Transistor	2SC2785 EL
Q10	1590000340	Transistor	RN1202
D1	1710000160	Diode	1SS133
D2	1710000160	Diode	1SS133
D3	1710000160	Diode	1SS133
D5	1710000160	Diode	1SS133
D6	1710000160	Diode	1SS133
D7	1710000160	Diode	1SS133
L1	6910000670	Coil	BT01RN1-A61-001
L2	6910000670	Coil	BT01RN1-A61-001
R1	7010003620	Resistor	ELR20J 47 kΩ
R2	7010003620	Resistor	ELR20J 47 kΩ
R3	7010003660	Resistor	ELR20J 100 kΩ
R4	7010003440	Resistor	ELR20J 2.2 kΩ
R13	7210001760	Variable Resistor	EVU-FLAEA4B16 (1MB) [DELAY]
R14	7210001750	Variable Resistor	EVU-FLAEA4B13 (1KB) [LEVEL]
R15	7210001770	Variable Resistor	EVU-FLAEA4C55 (500KC) [KEY SPEED]
R17	7010003480	Resistor	ELR20J 4.7 kΩ
R18	7010003480	Resistor	ELR20J 4.7 kΩ
R19	7010003490	Resistor	ELR20J 5.6 kΩ
R20	7010003590	Resistor	ELR20J 27 kΩ
R21	7010003400	Resistor	ELR20J 1 kΩ
R22	7010003340	Resistor	ELR20J 330 Ω
R23	7010003520	Resistor	ELR20J 8.2 kΩ
R24	7010003320	Resistor	ELR20J 220 Ω
R26	7010003560	Resistor	ELR20J 18 kΩ
R27	7010003780	Resistor	ELR20J 1 MΩ
R28	7010003400	Resistor	ELR20J 1 kΩ
R29	7010003700	Resistor	ELR20J 220 kΩ
R30	7010001110	Resistor	R25XJ 470 Ω
R32	7310001070	Trimmer	RV-174 (RH06 52CN2J04B)331
R33	7010003510	Resistor	ELR20J 6.8 kΩ
R39	7010003520	Resistor	ELR20J 8.2 kΩ
R40	7010003660	Resistor	ELR20J 100 kΩ

[SW(B) UNIT]

REF. NO.	ORDER NO.	DESCRIPTION	
R41	7010003400	Resistor	ELR20J 1 kΩ
R42	7210001880	Variable Resistor	EVU-FLAEA4C13 (1KC) [SIDE TONE]
C1	4010000520	Ceramic	DD108 B 472K 50V
C2	4510003880	Electrolytic	10 MV 47 HW
C3	4310000060	Mylar	F2D 50V 223K
C4	4310000060	Mylar	F2D 50V 223K
C5	4310000060	Mylar	F2D 50V 223K
C6	4010004840	Ceramic	DD305 F 104Z 12V
C7	4550000340	Tantalum	DN 1C 100M
C8	4510003840	Electrolytic	50 MV 1 SW
C9	4550000350	Tantalum	DN 1V 010M
C10	4010000520	Ceramic	DD108 B 472K 50V
C11	4530000270	Capacitor Array	B8XC0114-32N
C12	4040000260	Barrier Layer	UZE 08X 104M
C13	4040000260	Barrier Layer	UZE 08X 104M
C14	4040000240	Barrier Layer	UAT 08X 333M
C15	4040000190	Barrier Layer	UAT 05X 103K
C16	4550000340	Tantalum	DN 1C 100M
C17	4010004840	Ceramic	DD305 F 104Z 12V
C18	4040000260	Barrier Layer	UZE 08X 104M
DS1	5080000060	LED	BQ044-32582A
ME1	5510000350	Meter	ME-27 [MULTI-FUNCTION]
S3	2230000810	Switch	ESB-64801 [PREAMP]
S4	2230000810	Switch	ESB-64801 [SP SEPARATE]
S5	2230000800	Switch	SW-112 (SPPH2) [BK-IN]
S6	2230000800	Switch	SW-112 (SPPH2) [COMP]
S7	2230000810	Switch	ESB-64801 [AGC]
S8	2230000800	Switch	SW-112 (SPPH2) [ELECT-KEY]
S9	2230000810	Switch	ESB-64801 [NB]
S10	2230000810	Switch	ESB-64801 [GENE ATT]
S11	2230000800	Switch	SW-112 (SPPH2) [LOCK]
S12	2230000810	Switch	ESB-64801 [S-RF/C-ALC]
S13	2230000820	Switch	EVQ-QS2 05K [MODE-SELL]
S14	2230000820	Switch	EVQ-QS2 05K [MULTI-BAND]
S15	2230000820	Switch	EVQ-QS2 05K [MAIN(SCAN)]
S16	2230000820	Switch	EVQ-QS2 05K [SUB(SCAN)]
S17	2230000820	Switch	EVQ-QS2 05K [FM(FM)]
S18	2230000820	Switch	EVQ-QS2 05K [SSB(FM-W)]
S19	2230000820	Switch	EVQ-QS2 05K [CW/N(AM)]
S20	2230000820	Switch	EVQ-QS2 05K [GENE]
S21	2230000820	Switch	EVQ-QS2 05K [SPEECH]
EP1	0910023974	P.C. Board	B 2304D (SW(B))

[SATE UNIT]

REF. NO.	ORDER NO.	DESCRIPTION	
D1	1710000160	Diode	1SS133
D2	1710000160	Diode	1SS133
D3	1710000160	Diode	1SS133
D4	1710000160	Diode	1SS133
D5	1710000160	Diode	1SS133
D6	1710000160	Diode	1SS133
S1	2210000170	Switch	SRBU16003A [SATELLITE]
EP1	0910024083	P.C. Board	B 2306C (SATE)

[NOTCH UNIT]

REF. NO.	ORDER NO.	DESCRIPTION
R1	7210001780	Variable Resistor RV-166(RK097111) 10KB [NOTCH]
R2	7010003400	Resistor ELR20J 1 k Ω
EP1	0910023923	P.C. Board B 2309C (NOTCH)

[MEMO UNIT]

REF. NO.	ORDER NO.	DESCRIPTION
S1	2280001230	Switch SW-111 [MEMO-CH]
EP1	0910023913	P.C. Board B 2308C (MEMO)

[PHONE UNIT]

REF. NO.	ORDER NO.	DESCRIPTION
R1	7010003280	Resistor ELR20J 100 Ω
R2	7010003280	Resistor ELR20J 100 Ω
EP1	0910024073	P.C. Board B 2305C (PHONE)

[SENSOR UNIT]

REF. NO.	ORDER NO.	DESCRIPTION
Q1	1170000140	Transistor IS-486
Q2	1170000140	Transistor IS-486
Q3	1170000140	Transistor IS-486
R1	7030000420	Resistor MCR10EZHZ 2.2 k Ω (222)
R2	7030000420	Resistor MCR10EZHZ 2.2 k Ω (222)
C1	4030001140	Ceramic GRM40 F 103Z 50PT
C2	4030001140	Ceramic GRM40 F 103Z 50PT
C3	4030001140	Ceramic GRM40 F 103Z 50PT
C4	4030001140	Ceramic GRM40 F 103Z 50PT
DS1	1170000150	LED GL-480
DS2	1170000150	LED GL-480
DS3	1170000150	LED GL-480
EP1	0910022873	P.C. Board B 2210C (SENSOR)

[MIC UNIT]

REF. NO.	ORDER NO.	DESCRIPTION
EP1	0910006331	P.C. Board B 792A (MIC)

[VR UNIT]

REF. NO.	ORDER NO.	DESCRIPTION
Q1	1530000940	Transistor 2SC1571G
Q2	1530000591	Transistor 2SC2785 EL
Q3	1590000340	Transistor RN1202
Q4	1590000340	Transistor RN1202
Q5	1590000310	FET 2SJ105-GR
Q6	1590000350	Transistor RN1204
Q7	1590000370	Transistor RN2204
Q8	1530000591	Transistor 2SC2785 EL
Q9	1530000591	Transistor 2SC2785 EL
Q10	1530000591	Transistor 2SC2785 EL
Q11	1530000591	Transistor 2SC2785 EL
D1	1710000580	Diode 1SS265
D2	1710000580	Diode 1SS265
D4	1710000160	Diode 1SS133
L1	6180000960	Coil LAL 03NA 102K
R1	7210001790	Variable Resistor RV-163(RK1242320) 10KBX2/10KC [AF/SQL(MAIN)]
R2	7210001790	Variable Resistor RV-163(RK1242320) 10KBX2/10KC [AF/SQL(SUB)]
R3	7210001800	Variable Resistor RV-164(RK1242320) 10KB/1KB/10KC [TONE/RF]
R4	7210001810	Variable Resistor RV-165(RK124221) 10KBX2 [MIC/RF PWR]
R5	7010004190	Resistor R20J 1 k Ω
R6	7010003480	Resistor ELR20J 4.7 k Ω
R7	7010003660	Resistor ELR20J 100 k Ω
R8	7010004030	Resistor R20J 47 Ω
R9	7010004190	Resistor R20J 1 k Ω
R10	7010003580	Resistor ELR20J 22 k Ω
R11	7010003400	Resistor ELR20J 1 k Ω
R12	7010003530	Resistor ELR20J 10 k Ω
R13	7010003420	Resistor ELR20J 1.5 k Ω
R14	7010003390	Resistor ELR20J 820 Ω
R15	7010003440	Resistor ELR20J 2.2 k Ω
R17	7010003480	Resistor ELR20J 4.7 k Ω
R19	7010004410	Resistor R20J 47 k Ω
R20	7010004270	Resistor R20J 4.7 k Ω
R21	7010004320	Resistor R20J 10 k Ω
R22	7010004190	Resistor R20J 1 k Ω
R23	7010004320	Resistor R20J 10 k Ω
R24	7010003360	Resistor ELR20J 470 Ω
R25	7010003360	Resistor ELR20J 470 Ω
R26	7010004320	Resistor R20J 10 k Ω
R27	7010004490	Resistor R20J 220 k Ω
R28	7010003400	Resistor ELR20J 1 k Ω
R29	7010003400	Resistor ELR20J 1 k Ω
R30	7010003660	Resistor ELR20J 100 k Ω
R31	7010003400	Resistor ELR20J 1 k Ω
R32	7010003400	Resistor ELR20J 1 k Ω
R33	7010004250	Resistor R20J 3.3 k Ω
C1	4040000150	Barrier Layer UAT 05X 472K
C2	4510001730	Electrolytic 50 RBP 0.47 μ F
C3	4510004180	Electrolytic 10 MV 220 HW

[VR UNIT]

REF. NO.	ORDER NO.	DESCRIPTION	
C4	4040000250	Barrier Layer	UAT 08X 473M
C5	4510003880	Electrolytic	10 MV 47 HW
C6	4510003940	Electrolytic	25 MV 4R7 HW
C7	4510003940	Electrolytic	25 MV 4R7 HW
C8	4510003800	Electrolytic	25 MV 4R7 SW
C11	4510003940	Electrolytic	25 MV 4R7 HW
C12	4510003890	Electrolytic	16 MV 10 HW
C13	4510004160	Electrolytic	10 MV 220 HW
C15	4510003890	Electrolytic	16 MV 10 HW
C16	4510004160	Electrolytic	10 MV 220 HW
C17	4040000260	Barrier Layer	UZE 08X 104M
C18	4040000260	Barrier Layer	UZE 08X 104M
S1	2220000420	Switch	ESD11H120
EP1	0910024004	P.C. Board	B 2307D (VR)

[LED UNIT]

REF. NO.	ORDER NO.	DESCRIPTION	
Q1	1590000350	Transistor	RN1204
D1	1710000160	Diode	1SS133
D2	1710000160	Diode	1SS133
R1	7010003420	Resistor	ELR20J 1.5 kΩ
R2	7010004160	Resistor	R20J 560 Ω
R3	7010004160	Resistor	R20J 560 Ω
R4	7010004210	Resistor	R20J 1.5 kΩ
R5	7010003530	Resistor	ELR20J 10 kΩ
R6	7010003550	Resistor	ELR20J 15 kΩ
R7	7010004320	Resistor	R20J 10 kΩ
R8	7010003550	Resistor	ELR20J 15 kΩ
R9	7010004170	Resistor	R20J 680 Ω
R10	7010004130	Resistor	R20J 330 Ω
DS1	5040001430	LED	SLB-25VR 3F
DS2	5040001460	LED	SLB-25MG 3F
DS3	5040001460	LED	SLB-25MG 3F
DS4	5040001430	LED	SLB-25VR 3F
DS5	5040001420	LED	SPB-25MVW F
EP1	0910024571	P.C. Board	B 2345A (LED)

[CONT UNIT]

REF. NO.	ORDER NO.	DESCRIPTION	
L1	6140001220	Coil	LR-147
C38	4010004440	Ceramic	DE7090 B 102K VA1 -KC
C39	4010004440	Ceramic	DE7090 B 102K VA1 -KC

[SW-REG UNIT]

REF. NO.	ORDER NO.	DESCRIPTION	
IC1	1710000320	Photo Interrupter N110	
IC2	1110000190	IC μPC1042C	
Q1	1510000050	Transistor	2SA1015-Y
Q2	1530002160	Transistor	2SC3162
Q3	1530002160	Transistor	2SC3162
Q4	1530000750	Transistor	2SC2307
Q5	1530000750	Transistor	2SC2307
D1	1790000190	Diode	KBPC806
D2	1710000350	Diode	1N4002
D3	1710000350	Diode	1N4002
D4	1710000690	Diode	FML-32S
D5	1710000690	Diode	FML-32S
L2	6140000460	Coil	LR-66
L3	6140000470	Coil	LR-67
L4	6180000280	Coil	LB4-102J
L5	6140000450	Coil	LR-65A
L6	5920000080	Coil	TC-2A
L8	5920000120	Coil	TI-5
R1	7010004800	Resistor	R50XJ 68 kΩ
R2	7010004800	Resistor	R50XJ 68 kΩ
R3	7010004810	Resistor	R50XJ 150 kΩ
R4	7010001380	Resistor	R25XJ 68 kΩ
R5	7100000120	Resistor	SRW2P 3 Ω (3R0)
R6	7010000190	Resistor	ELR25J 33 Ω
R7	7010001210	Resistor	R25XJ 3.3 kΩ
R9	7010000500	Resistor	ELR25J 10 kΩ
R10	7010000450	Resistor	ELR25J 4.7 kΩ
R11	7010000330	Resistor	ELR25J 470 Ω
R12	7010004800	Resistor	R50XJ 68 kΩ
R13	7010004800	Resistor	R50XJ 68 kΩ
R14	7310000970	Trimmer	EVN5AC A00B14 (103)
R15	7010000520	Resistor	ELR25J 15 kΩ
R16	7010000450	Resistor	ELR25J 4.7 kΩ
R17	7010000450	Resistor	ELR25J 4.7 kΩ
R18	7010000450	Resistor	ELR25J 4.7 kΩ
R19	7310000990	Trimmer	EVN5AC A00BQ4 (473)
R20	7010000500	Resistor	ELR25J 10 kΩ
R21	7010000480	Resistor	ELR25J 6.8 kΩ
R22	7010000440	Resistor	ELR25J 3.9 kΩ
R23	7010000670	Resistor	ELR25J 220 kΩ
R24	7010000500	Resistor	ELR25J 10 kΩ
R25	7010000330	Resistor	ELR25J 470 Ω
R26	8930003890	Resistor	PX306
R27	7010000520	Resistor	ELR25J 15 kΩ
R28	7010000090	Resistor	ELR25J 4.7 Ω
R29	7010000090	Resistor	ELR25J 4.7 Ω
R30	7010000870	Resistor	R25XJ 4.7 Ω
R31	7010000870	Resistor	R25XJ 4.7 Ω
R32	7010000950	Resistor	R25XJ 22 Ω
R33	7010000950	Resistor	R25XJ 22 Ω
R34	7080000100	Resistor	RSF3B 100 Ω J
R35	7070000260	Resistor	CRH200 R-02J 22 Ω (220)
R36	7070000240	Resistor	CRH100X R-02J 3.9 Ω (3R9)
R37	7540000030	Absorber	ERZC07DK431
C1	4010004240	Ceramic	DE7100 F 222M VA1 -KC
C2	4010004240	Ceramic	DE7100 F 222M VA1 -KC
C3	4010004130	Ceramic	DD09 B 222K 500V
C4	4010004130	Ceramic	DD09 B 222K 500V
C5	4010004130	Ceramic	DD09 B 222K 500V
C6	4010004130	Ceramic	DD09 B 222K 500V
C7	4510000350	Electrolytic	CS042DRT681 (HPF2 00 680 μF)
C8	4510000350	Electrolytic	CS042DRT681 (HPF2 00 680 μF)
C9	4510002780	Electrolytic	16 SS 10 μF
C10	4010000530	Ceramic	DD112 B 103K 50V
C11	4010000530	Ceramic	DD112 B 103K 50V
C12	4510002900	Electrolytic	25 SS 470 μF

[SW-REG UNIT]

REF. NO.	ORDER NO.	DESCRIPTION	
C13	4030001210	Ceramic	C5650 Y5V 1H 684Z
C14	4510000570	Electrolytic	16 MS 2200 μ F
C15	4010004440	Ceramic	DE7090 B 102K VA1 -KC
C16	4010004440	Ceramic	DE7090 B 102K VA1 -KC
C17	4010004210	Ceramic	DD63 YZ 203Z 500V
C18	4510000080	Electrolytic	250 RHJ 33 μ F
C19	4510000080	Electrolytic	250 RHJ 33 μ F
C20	4010004240	Ceramic	DE7100 F 222M VA1 -KC
C21	4010000520	Ceramic	DD108 B 472K 50V
C22	4310000010	Mylar	F2D 50V 102K
C23	4510003050	Electrolytic	TMG 2G 335K (DC400V 3.3 μ F)
C24	4010004130	Ceramic	DD09 B 222K 500V
C25	4010004130	Ceramic	DD09 B 222K 500V
C26	4010004130	Ceramic	DD09 B 222K 500V
C27	4010004470	Ceramic	DD12 B 472K 500V
C28	4010004210	Ceramic	DD63 YZ 203Z 500V
C29	4010000410	Ceramic	DD107 SL 331J 50V
C30	4510000090	Electrolytic	ECEA16Z470
C31	4510000090	Electrolytic	ECEA16Z470
C32	4510000090	Electrolytic	ECEA16Z470
C33	4510000090	Electrolytic	ECEA16Z470
C34	4510002840	Electrolytic	25 SS 10 μ F
C35	4010004650	Ceramic	DD410 SR 224M 12V
C36	4010004650	Ceramic	DD410 SR 224M 12V
C37	4310000060	Mylar	F2D 50V 223K
RL1	6330000200	Relay	VS-12TBN-E

4

調整方法

4-1 調整の準備

■使用測定器

測定器	規格	測定器	規格
定電圧電源	出力電圧 : DC 13.8V 電流容量 : 20A 以上	直流電圧計	入力インピーダンス : 50kΩ/DC 以上
パワー計 (終端型ダミーロード)	測定電力範囲 : 1~60 W 周波数範囲 : 0.1~500 MHz インピーダンス : 50Ω SWR : 1.2 : 1 以下	AC ミリボルトメーター	測定範囲 : 10mV~10V
周波数カウンター	周波数範囲 : 0.1~470 MHz 周波数安定度 : ± 1ppm 以上 入力感度 : 100 mV 以上	外部スピーカー	インピーダンス : 8Ω
高周波電圧計	周波数範囲 : 0.1~470 MHz 測定範囲 : 0.01~10 V	直流電流計	測定容量 : 1 A、20 A
高周波信号発生器 (SSG)	周波数範囲 : 0.1~470 MHz 出力レベル : - 20~90 dBμ (0.1μV~32 mV)	低周波信号発生器 (AG)	周波数範囲 : 300~3000 Hz 出力レベル : 1~500 mV
オシロスコープ	周波数範囲 : DC~20MHz 測定範囲 : 0.01~10 V	アッテネーター	減衰量 : 40dB 以上 電力容量 : 60W 以上
		スペクトラムアナライザー	最小周波数 : 1000 MHz 測定範囲 : ± 100 kHz 以上
		FM デビューションメーター	最小周波数 : 470 MHz 測定範囲 : 0~10 kHz

■接続図

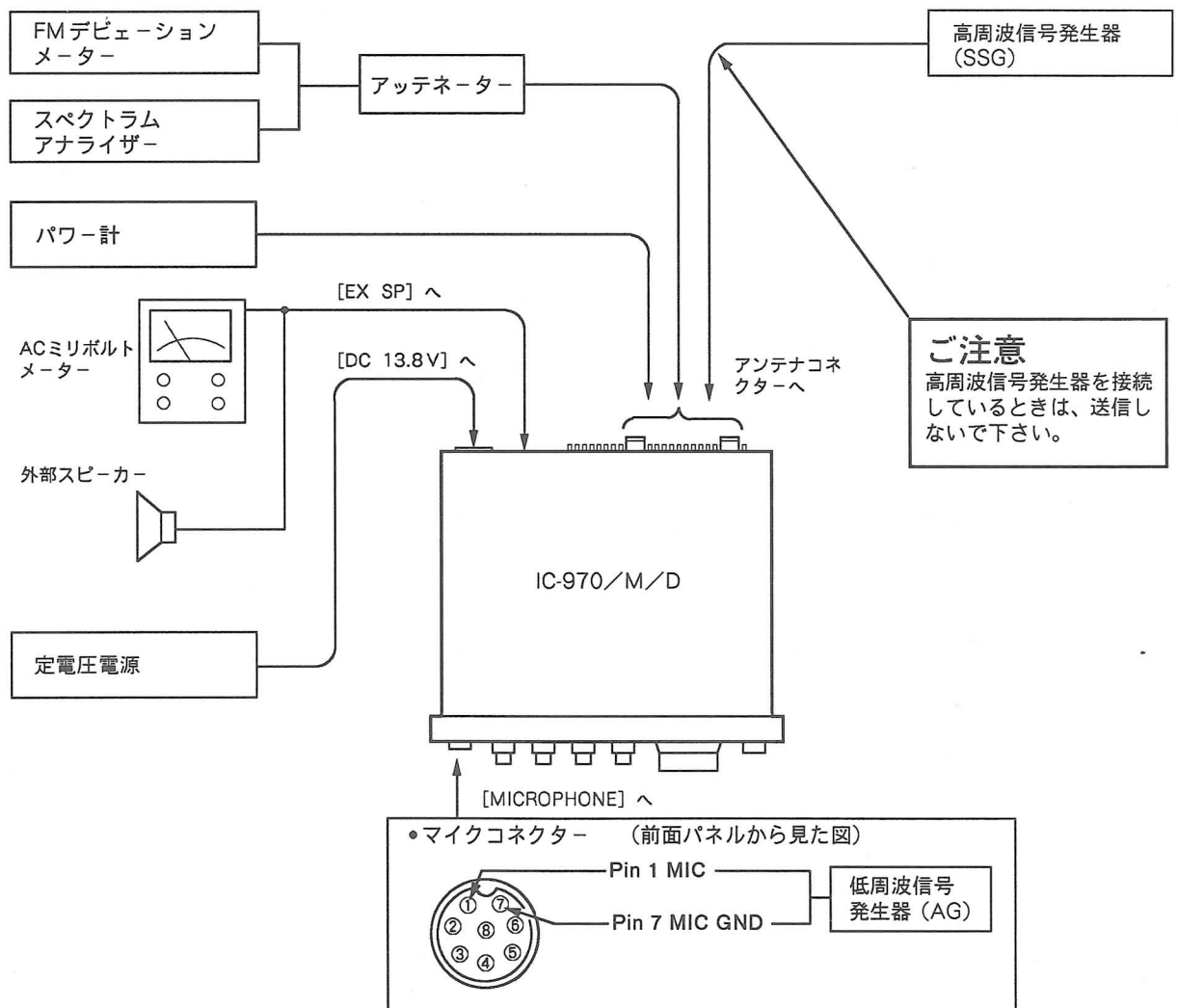

4-2 VHF PLL調整

調整項目	調整時の条件	ユニット	測定箇所	調整値	ユニット	調整箇所
基準周波数調整	1 <ul style="list-style-type: none"> 表示周波数 : 145.0000 MHz MODE : USB 	OSC	J3、J4、J5の、いずれかに周波数カウンタ-を接続する。	30.2 MHz	OSC (B)	C7
通倍段出力調整	1 <ul style="list-style-type: none"> 表示周波数 : 145.0000 MHz MODE : USB 	PLL-A	R80に高周波電圧計を接続する。	最大 (約141 mV rms)	PLL-A	L24, L25
DDSクロック調整	1 <ul style="list-style-type: none"> 表示周波数 : 145.0000 MHz MODE : USB 	DDS	IC4 または IC5 の pin 11 に周波数カウンタ-を接続する。	5.24288 MHz	DDS	C1
LPL ロック電圧調整	1 <ul style="list-style-type: none"> 表示周波数 : 144.0500 MHz MODE : FM 	PLL-A	R91に直流電圧計を接続する。	1.0 V	PLL-A	C121
	2 <ul style="list-style-type: none"> 表示周波数 : 144.0490 MHz MODE : FM 			約 1.2 V		確認
LPL VCO出力調整	1 <ul style="list-style-type: none"> 表示周波数 : 145.0000 MHz MODE : FM 	PLL-A	R106に高周波電圧計を接続する。	約 - 2 dBm	PLL-A	L31
HPL ロック電圧調整	1 <ul style="list-style-type: none"> 表示周波数 : 146.0000 MHz MODE : FM 	PLL-A	R46に直流電圧計を接続する。	3.0 V	PLL-A	L51
	2 <ul style="list-style-type: none"> 表示周波数 : 136.0000 MHz MODE : FM 			約 2.0 V		確認
	3 <ul style="list-style-type: none"> 表示周波数 : 174.0000 MHz MODE : FM 			約 6.5 V		確認
HPL VCO出力調整	1 <ul style="list-style-type: none"> 表示周波数 : 145.0000 MHz MODE : FM 	PLL-A	P1 とア-ース間に50Ωの抵抗を入れたあと、高周波電圧計を接続する。	0 dBm 以上	PLL-A	L6
注意 : 調整が完了すればP1を元通りにしておく。						

• OSC UNIT

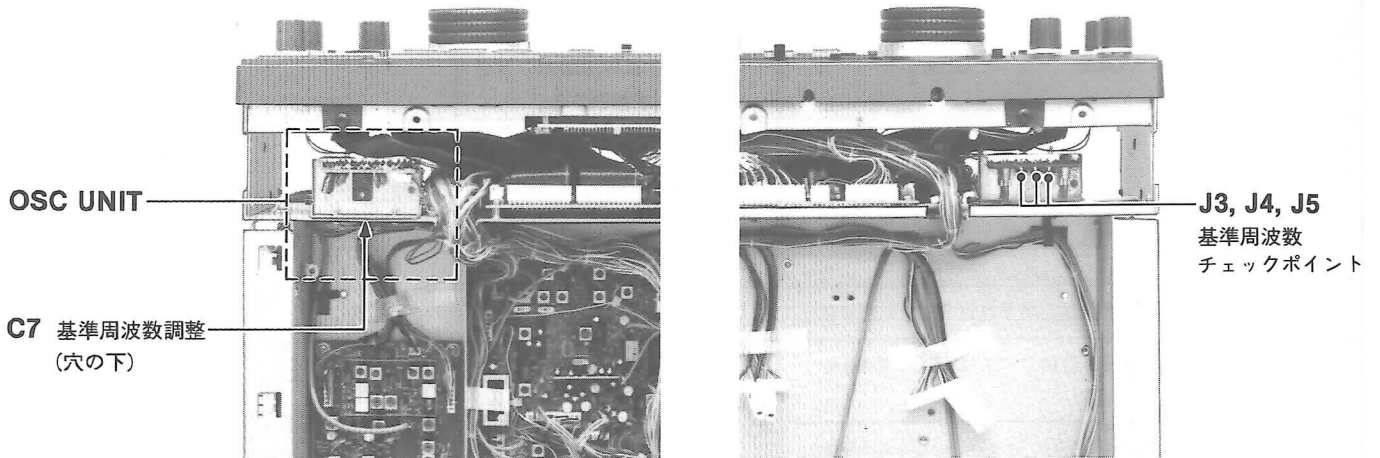

• PLL-A UNIT

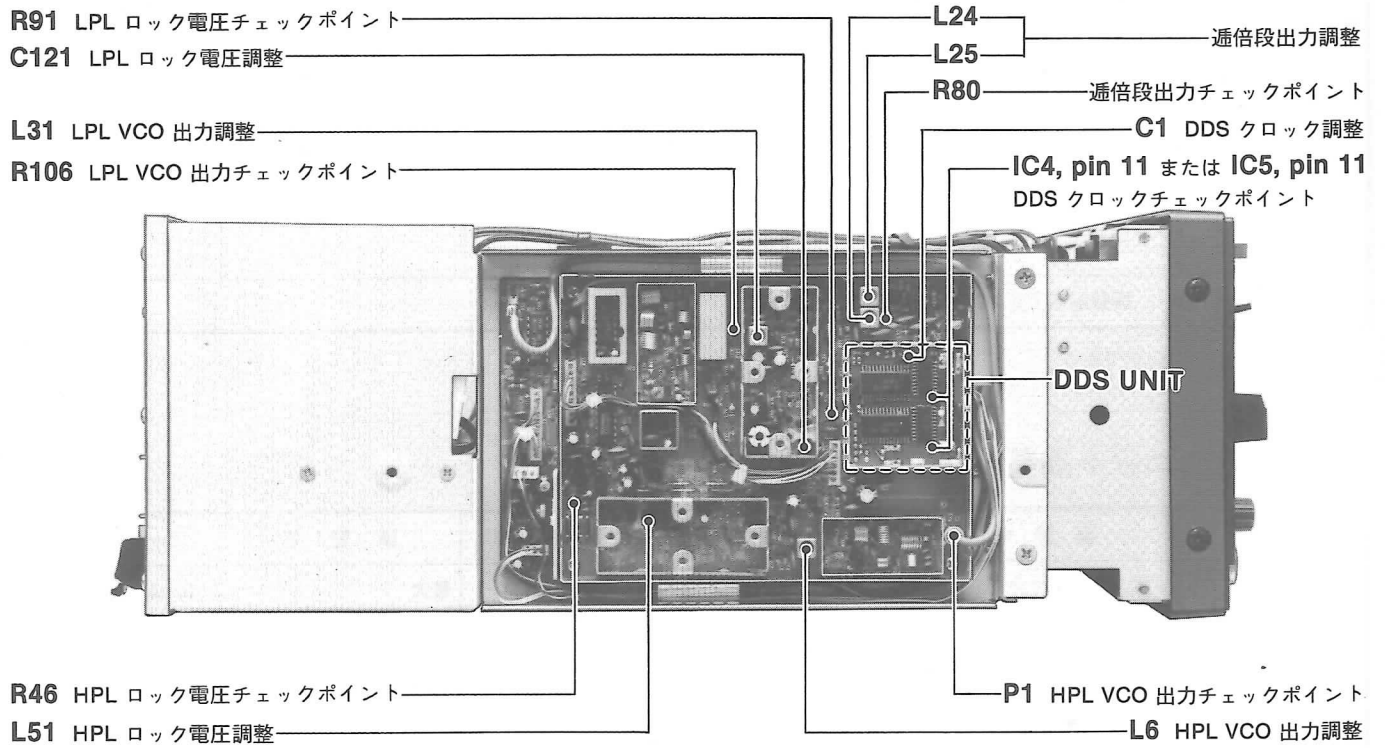

4-3 UHF PLL調整

調整項目	調整時の条件	ユニット	測定箇所	調整値	ユニット	調整箇所
DDS クロック調整	1 •表示周波数 : 435.0000 MHz •MODE : USB	DDS	IC4 または IC5のpin 11に周波数カウンタ ーを接続する。	5.24288 MHz	DDS	C1
2nd LO 周波数調整	1 •表示周波数 : 435.0000 MHz •MODE : USB	PLL-B	P3 とアース間に50Ω の抵抗を入れたあと、 高周波電圧計を接続 する。	-10 dBm 以上	PLL-B	L4, L5
注意 : 調整が完了すればP3を元通りにしておく。						
LPL ロック 電圧調整	1 •表示周波数 : 430.0500 MHz •MODE : FM	PLL-B	R62に直流電圧計を 接続する。	1.0 V	PLL-B	C121
	2 •表示周波数 : 430.0490 MHz •MODE : FM			約 1.15 V		確認
	3		R76にオシロスコー プを接続する。	最大		L25, L24
HPL ロック 電圧調整	1 •表示周波数 : 430.0000 MHz •MODE : FM	PLL-B	R4に直流電圧計を接 続する。	2.0 V	PLL-B	C23
	2 •表示周波数 : 440.0000 MHz •MODE : FM			約 3.0 V		確認
1st LO 周波数調整	1	次の調整は電源投入後、5分以上経過してから行ってください。				
	2 •表示周波数 : 440.0000 MHz •MODE : FM	PLL-B	P1に周波数カウンタ ーを接続する。	368.7500 MHz	OSC (B)	C7
	3 •表示周波数 : 435.0000 MHz		P1 とアース間に50Ω の抵抗を入れたあと、 高周波電圧計を接続 する。	0 dBm 以上	PLL-B	確認
注意 : 調整が完了すればP1を元通りにしておく。						

4-4 RF-Aユニット調整

調整項目	調整時の条件	ユニット	測定箇所	調整値	ユニット	調整箇所
受信トータル ゲイン調整	1 •表示周波数 : 145.0000 MHz •MODE : USB •SSGを144MHz帯用アンテナコネク ターに接続する。	RF-A	右ページのように P1 に高周波電圧計を接 続する。	最大	RF-A	L14
	2 レベル : 77dBμ (7.1 mV) MOD. : OFF •R22 : 右一杯			-12 dBm		R22

• PLL-B UNIT

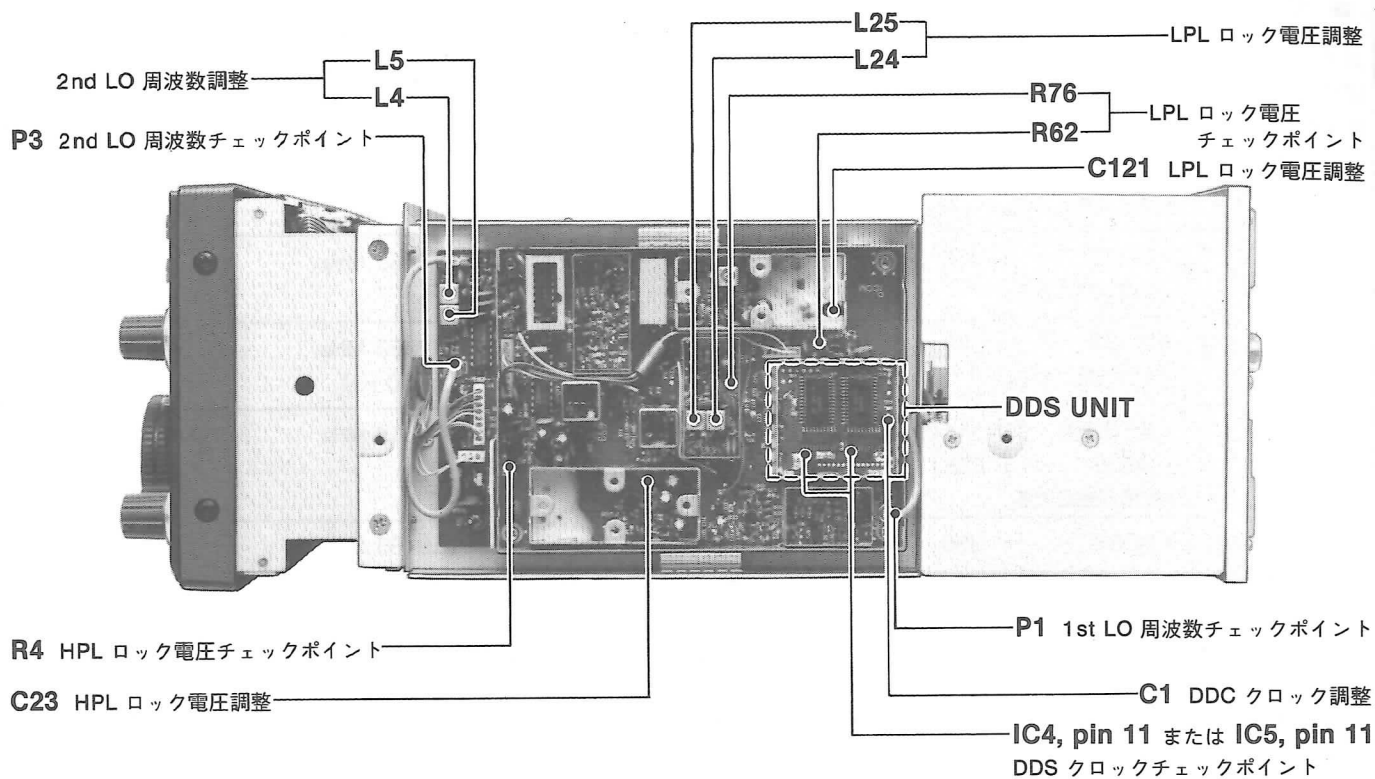

• RF-A, OSC UNIT

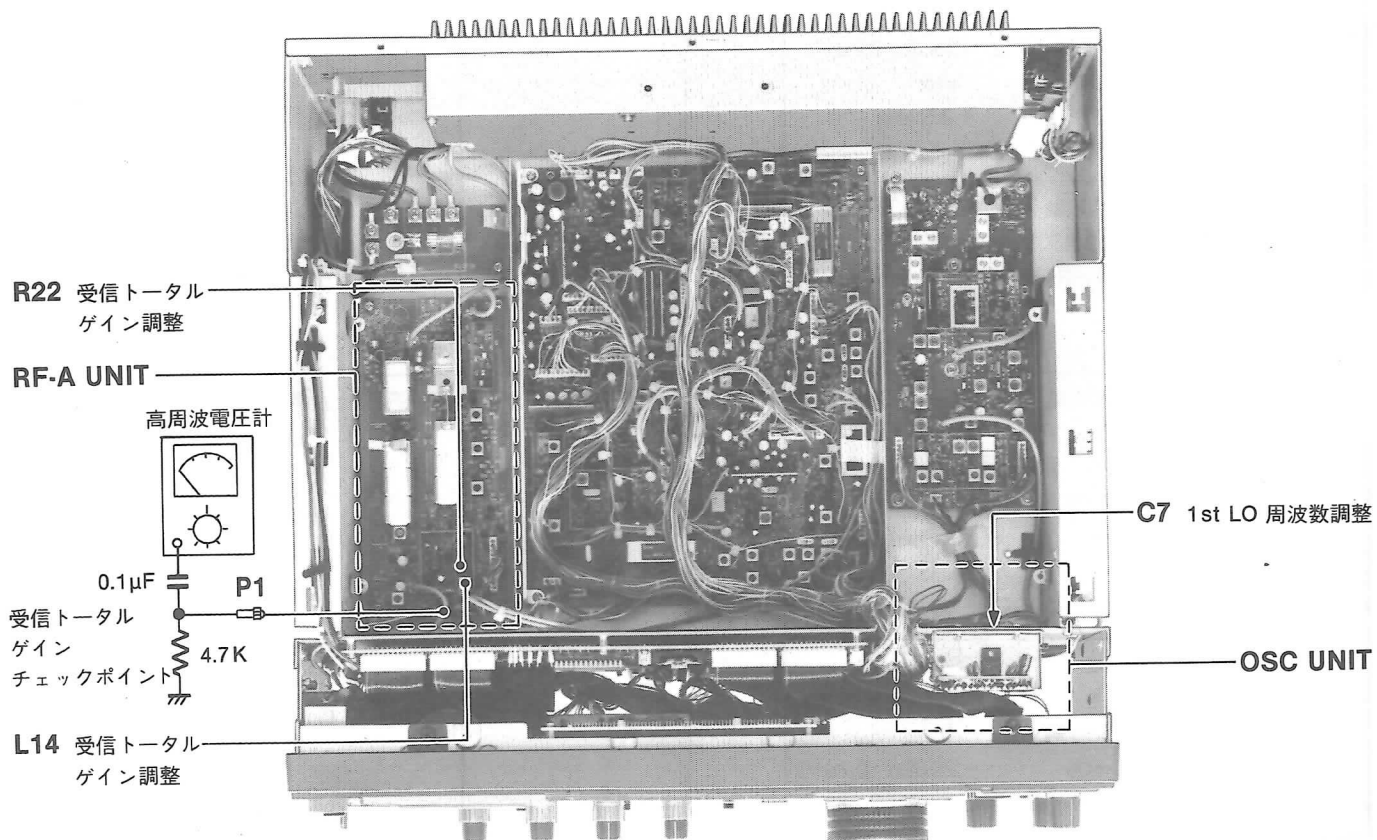

4-5 受信部調整 (1)

調整項目	調整時の条件	ユニット	測定箇所	調整値	ユニット	調整箇所
メインバンド BFO 周波数調整	1 •表示周波数 : 144.0000 MHz •MODE : LSB •受信状態にする。	MAIN	R92に周波数カウンタ-を接続する。	10.8515 MHz	MAIN	C76
	2 •MODE : CW •送信状態にする。			10.8491 MHz		L20
	3 •MODE : USB •受信状態にする。			10.8485 MHz		L21
	4 •MODE : CW •受信状態にする。			10.8483 MHz (± 150 Hz)		確認
サブバンド BFO 周波数調整	1 •表示周波数 : 144.0000 MHz •MODE : LSB •受信状態にする。	MAIN	R232に周波数カウンタ-を接続する。	10.9515 MHz	MAIN	C187
	2 •MODE : USB •受信状態にする。			10.9485 MHz		L36
	3 •MODE : CW •受信状態にする。			10.9483 MHz (± 150 Hz)		確認
FM用 LO周波数 調整	1 •表示周波数 : 144.0000 MHz •MODE : FM	MAIN	D1に周波数カウンタ-を接続する。	10.8500 MHz	MAIN	L10
	2 •R44 (MAIN) : 右一杯 •送信状態にする。		R332に周波数カウンタ-を接続する。	10.3950 MHz		L51
メインバンド 感度調整	1 •表示周波数 : 145.0000 MHz •MODE : FM •SSGを144MHz帯用アンテナコネクタ-に接続する。	前面 パネル	Sメーター	最大	以下の順に調整する。	
	2 レベル : 10dB μ (3.2 μ V) MOD. : 1 kHz DEV. : ± 3.5 kHz •受信状態にする。				RF-A	L14
	3 •表示周波数 : 435.0000 MHz •SSGを430MHz帯用アンテナコネクタ-に接続する。				MAIN	L11, L12, L13, L14, L15
	4 •表示周波数 : 145.0000 MHz •MODE : FM •SSGを144MHz帯用アンテナコネクタ-に接続する。 レベル : 10dB μ (3.2 μ V) MOD. : 1 kHz DEV. : ± 5 kHz	後面 パネル	EXT SP ジャックに ACミリボルトメータ-と8 Ω のスピーカ-を接続する。	オーディオ出力最大	MAIN	L23
	5 •MODE : USB •SSGを144MHz帯用アンテナコネクタ-に接続する。 レベル : -20dB μ (0.1 μ V) MOD. : OFF					L28, L29, L30 の順に調 整する。

• MAIN, RF-A, RF-B UNIT

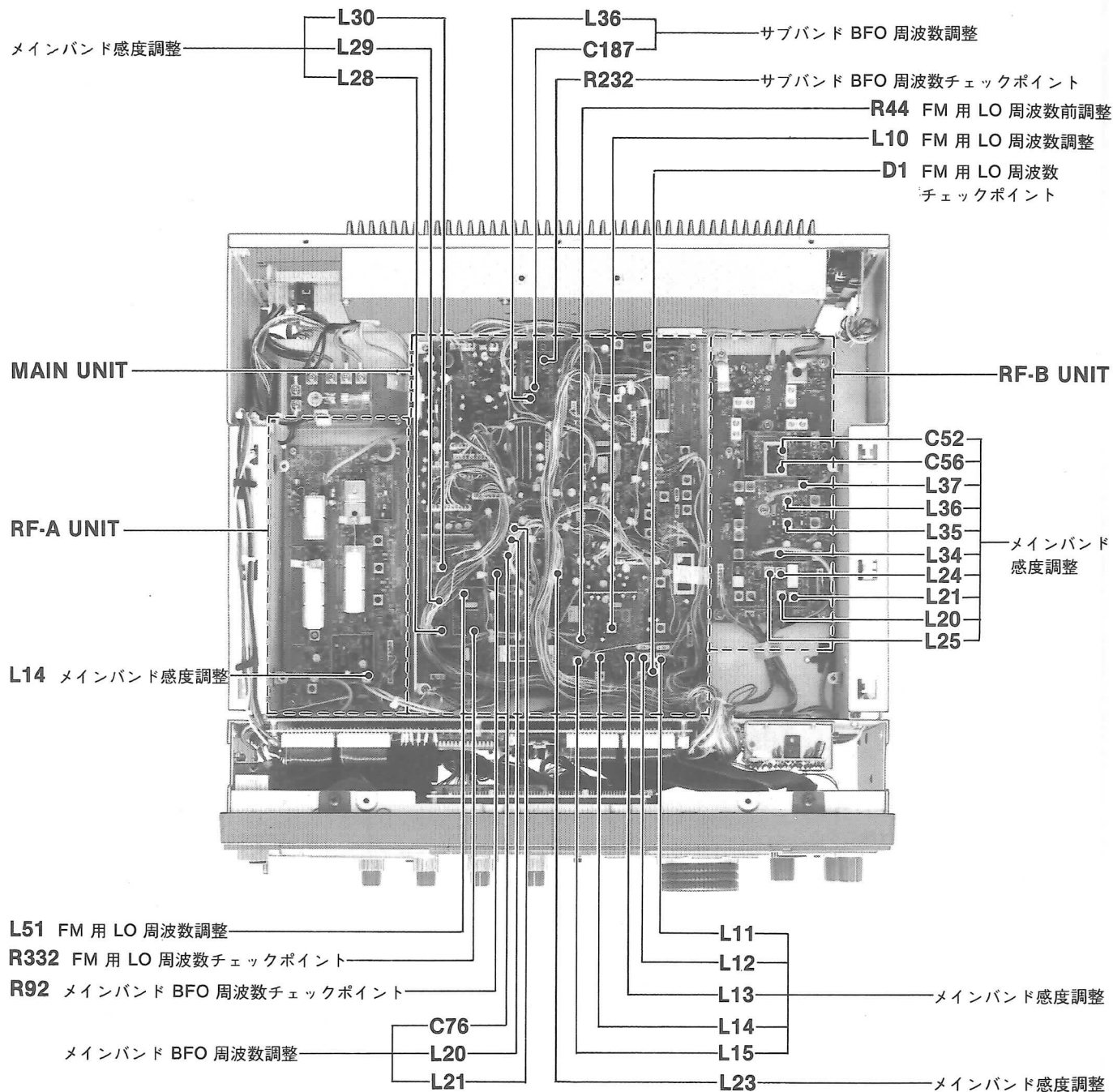

受信部調整 (2)

調整項目	調整時の条件	ユニット	測定箇所	調整値	ユニット	調整箇所
サブバンド 感度調整	1 <ul style="list-style-type: none"> 表示周波数 : 145.0000 MHz MODE : FM SSGを144MHz帯用アンテナコネクタ-に接続する。 レベル : 10dBμ (3.2μV) MOD. : 1 kHz DEV. : \pm 3.5 kHz 受信状態にする。 	MAIN	J28, pin 2 に直流電圧計を接続する。	最大	以下の順に調整する。	
					MAIN	L42, L43 L65, L44, L45
	2 <ul style="list-style-type: none"> 表示周波数 : 435.0000 MHz SSGを430MHz帯用アンテナコネクタ-に接続する。 受信状態にする。 	RF-B	L33, L32 L31			
3 <ul style="list-style-type: none"> 表示周波数 : 145.0000 MHz MODE : USB SSGを144MHz帯用アンテナコネクタ-に接続する。 レベル : -20dBμ (0.1μV) MOD. : OFF 受信状態にする。 	後面 パネル	EXT SP ジャックにACミリボルトメータと8 Ω のスピーカ-を接続する。	最大	MAIN	L38, L39 L40の順に調整する。	
メインバンド トータルゲイン調整	1 <ul style="list-style-type: none"> 表示周波数 : 145.0000 MHz MODE : USB SSGを144MHz帯用アンテナコネクタ-に接続する。 レベル : 34dBμ (50μV) MOD. : OFF 受信状態にする。 	後面 パネル	EXT SP ジャックにACミリボルトメータと8 Ω のスピーカ-を接続する。	0 dB	前面 パネル	MAIN AF GAIN ツマミ
	2 <ul style="list-style-type: none"> SSG レベル : OFF 			-20dB		
サブバンド トータルゲイン調整	1 <ul style="list-style-type: none"> 表示周波数 : 145.0000 MHz MODE : USB SSGを144MHz帯用アンテナコネクタ-に接続する。 レベル : 34dBμ (50μV) MOD. : OFF 受信状態にする。 	後面 パネル	EXT SP ジャックにACミリボルトメータと8 Ω のスピーカ-を接続する。	0 dB	前面 パネル	SUB AF GAIN ツマミ
	2 <ul style="list-style-type: none"> SSG レベル : OFF 			-20dB		

• MAIN, RF-B UNIT

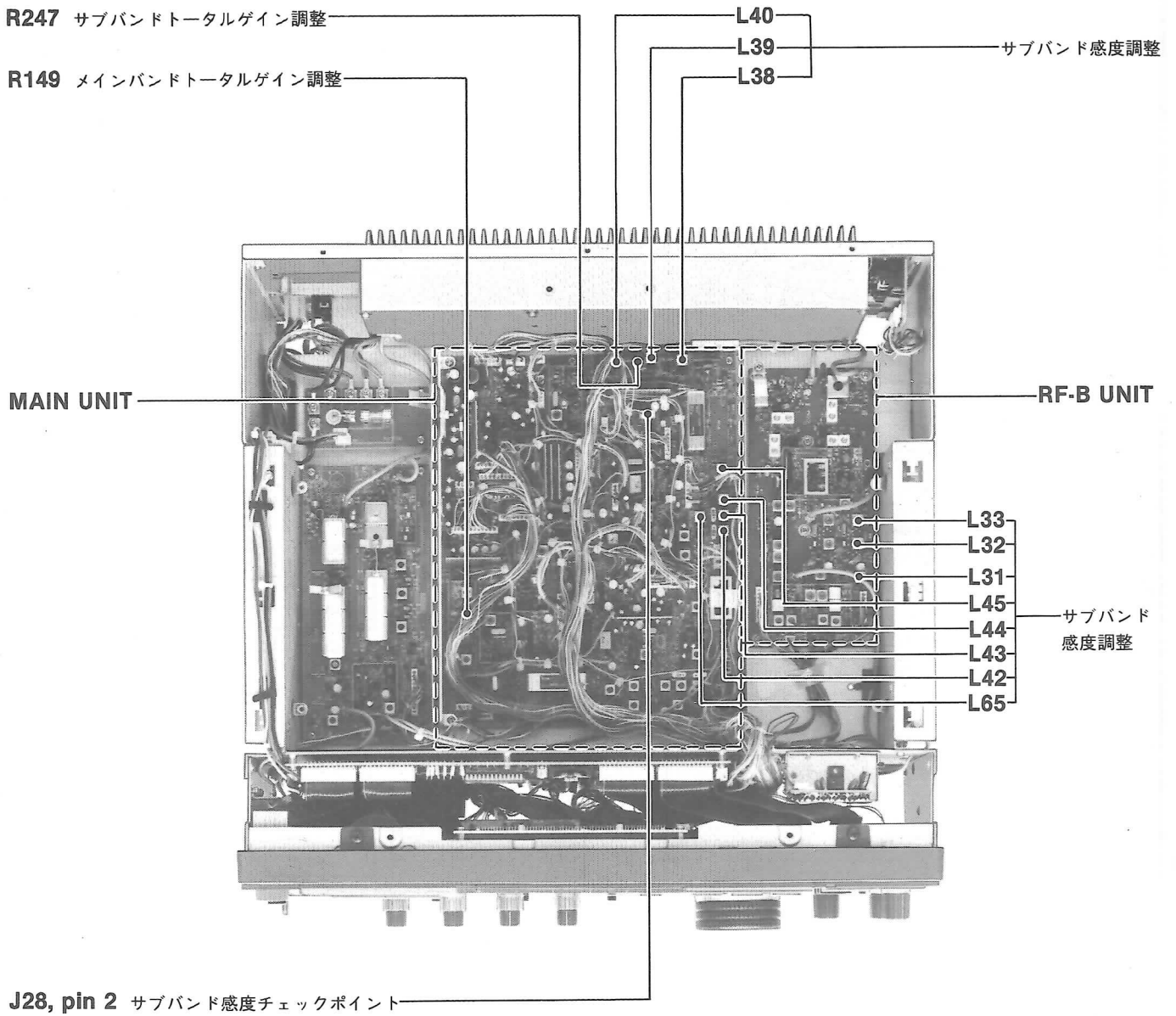

受信部調整 (3)

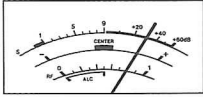
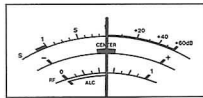
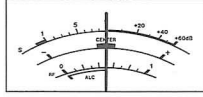
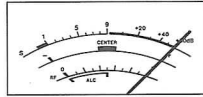
調整項目	調整時の条件	ユニット	測定箇所	調整値	ユニット	調整箇所
メインバンド センター メーター調整	1	前面 パネル	センターメーター	80 % 	MAIN	R320
	2			中央 		
	3	注意 : 上記の調整 1~2 を数回繰り返す。				
	4	前面 パネル	センターメーター	30%~80 %		確認
メインバンド Sメーター 調整	1	前面 パネル	Sメーター	S9 	MAIN	R160
	2			S9 + 60 dB 		R158
	3			最大		L25
	4			S9		R137
	5			S9 + 60 dB		R138
	6			S9		RF-B
	1			●表示周波数 : 145.0000 MHz ●MODE : USB ●S・RF/C・ALCスイッチ : S・RF ●SSGを144MHz帯用アンテナコネクタに接続する。 レベル : 10dBμ (3.2μV) MOD. : OFF		
	2			●SSG レベル : 60dBμ (1mV)		
	3			●表示周波数 : 145.0000 MHz ●MODE : FM ●SSGを144MHz帯用アンテナコネクタに接続する。 レベル : 0dBμ (1μV) MOD. : 1 kHz DEV. : ± 3.5 kHz		
	4			●SSG レベル : 10dBμ (3.2μV)		
	5			●SSG レベル : 40dBμ (0.1 mV)		
	6			●表示周波数 : 435.0000 MHz ●SSGを430MHz帯用アンテナコネクタに接続する。 レベル : 10dBμ (3.2μV)		

• MAIN, RF-B UNIT

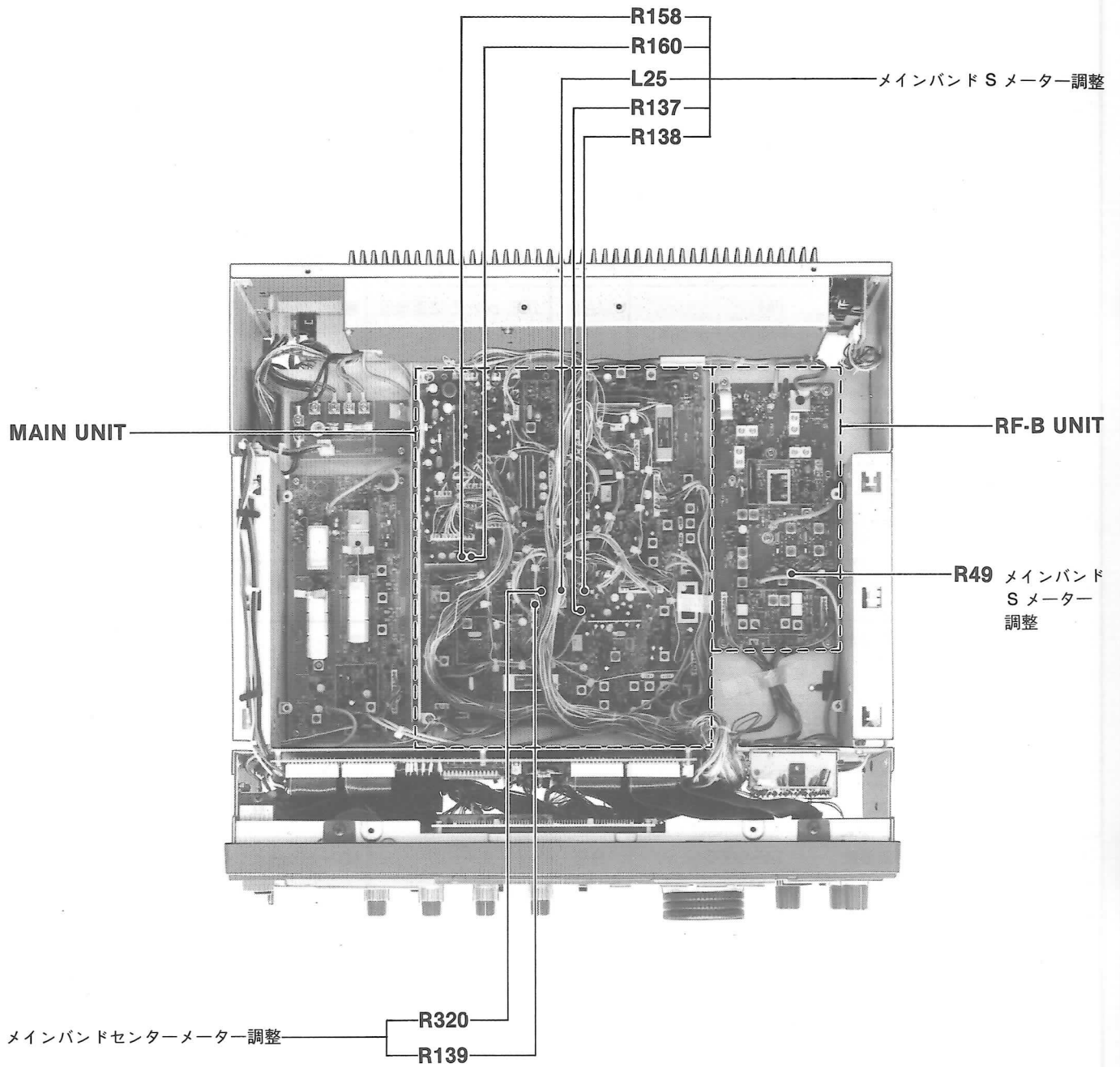

受信部調整 (4)

調整項目	調整時の条件	ユニット	測定箇所	調整値	ユニット	調整箇所
サブバンド Sメーター 調整	1	前面 パネル	Sメーター	S9 	MAIN	R260
	2			S9 + 60dB 		R257
	3	MAIN	J28, pin 2 に直流電 圧計を接続する。	最大	MAIN	L34
	4	前面 パネル	Sメーター	S9	MAIN	R215
	5			S9 + 60dB		R216
	6			RF-B	R43	
メインバンド RF GAIN 調整	1	前面 パネル	Sメーター	S9 + 60dB 	MAIN	R162
	2			S9 + 20dB 		

• MAIN, RF-B UNIT

R162 メインバンド RF GAIN 調整

R216

L34

R215

R257

R260

サブバンド S メーター調整

J28, pin 2 サブバンド S メーター
チェックポイント

MAIN UNIT

RF-B UNIT

R43 サブバンド
S メーター
調整

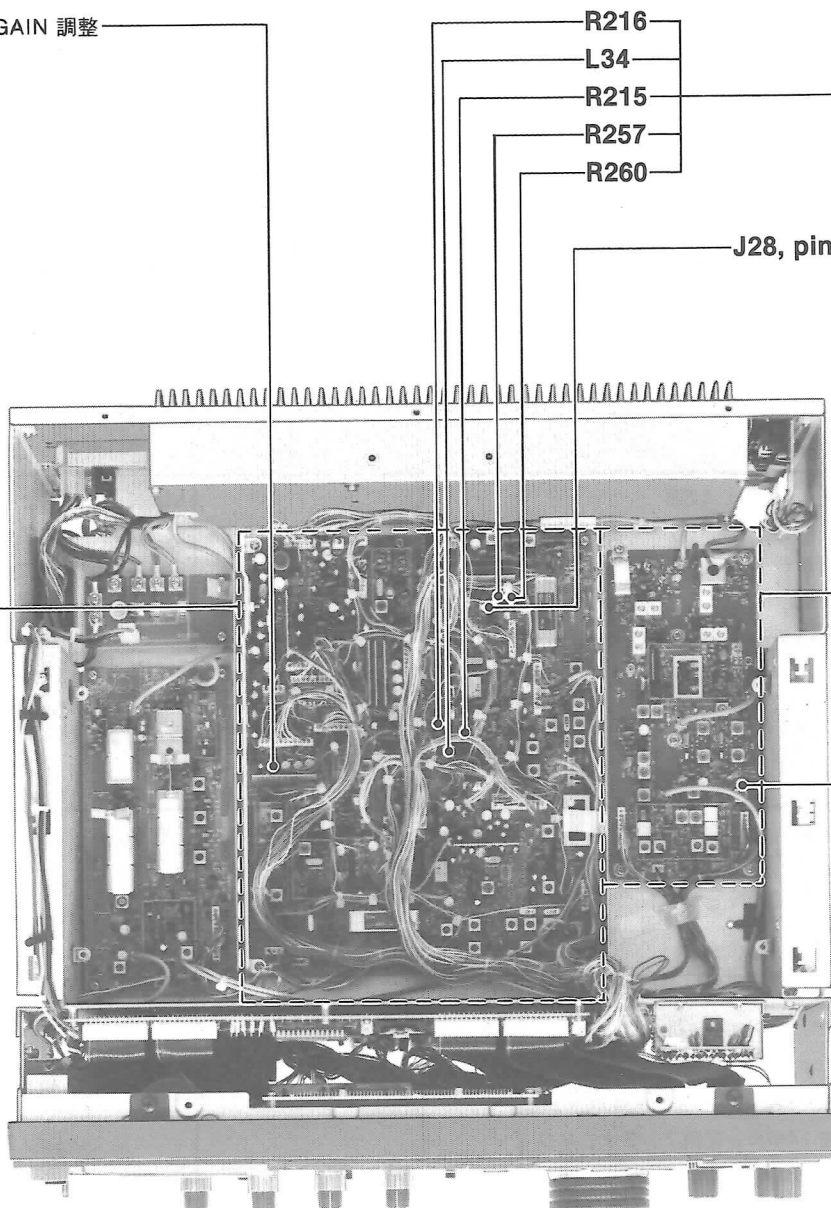

受信部調整 (5)

調整項目	調整時の条件	ユニット	測定箇所	調整値	ユニット	調整箇所
メインバンド ノイズ ブランカー 調整	1	上面 パネル	スピーカー	パルス性ノイズが最小 になるようにする。	MAIN	L4, L5
	2					L63, L64
サブバンド ノイズ ブランカー 調整	1					L63, L64
スケルチ調整	1			MAIN SQL および SUB SQL ツマミは 9時30分の位置で閉じ ること。		確認
	2			MAIN SQL および SUB SQL ツマミの9 時の位置にセットする。	MAIN	メインバンド R133 サブバンド R211
BEEP 調整	1	後面 パネル	EXT SP ジャックに オシロスコープと8Ω のスピーカーを接続 する。	0.5 V _{p-p}	MAIN	メインバンド R292 サブバンド R310
ワイドバンド 感度調整	1	前面 パネル	Sメーター	最大	RF-A	L27, L26 L25の順 に調整す る。
	2					注意：調整が完了すればR68を元通りにしておく。

• MAIN, RF-A UNIT

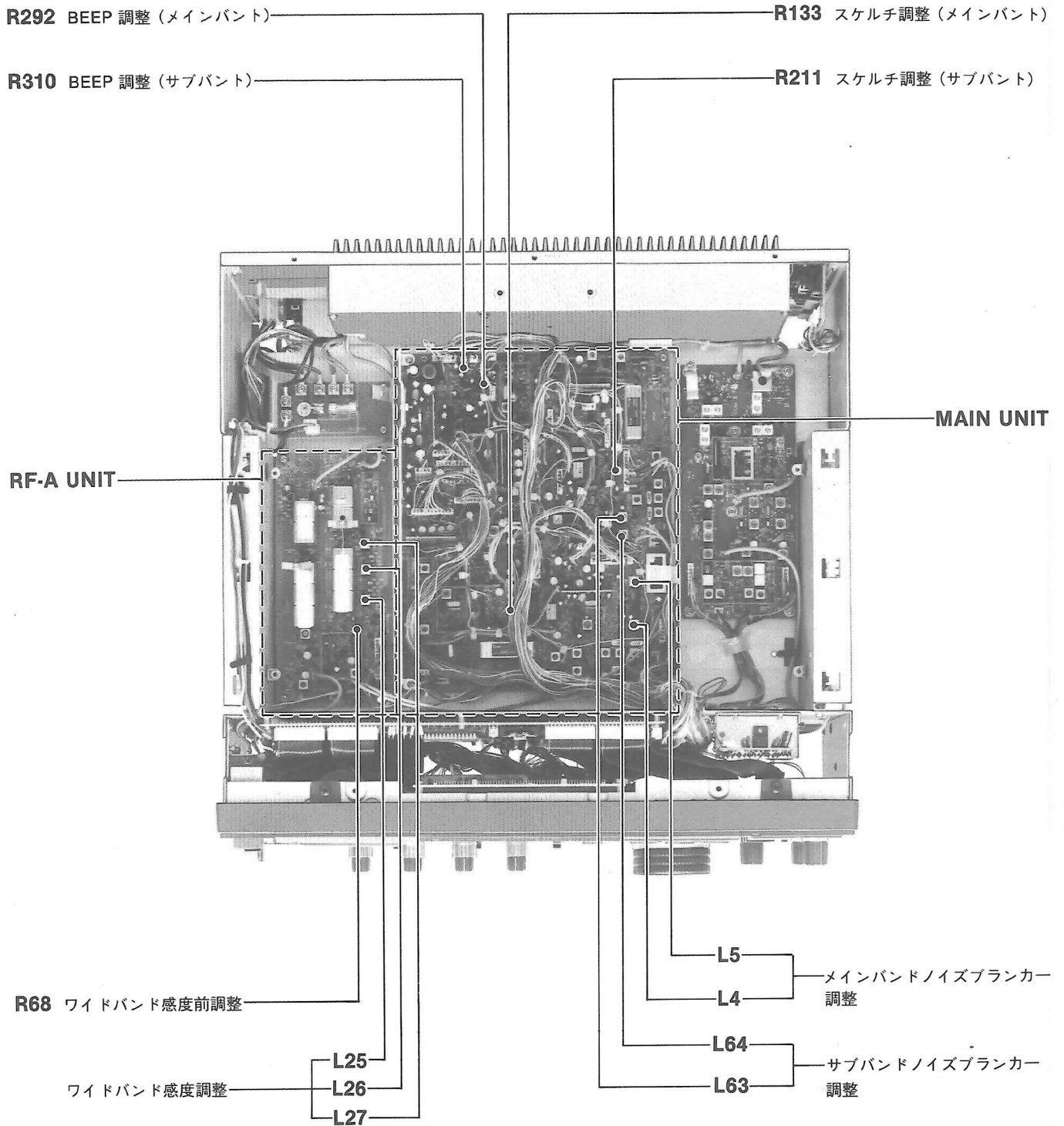

4-6 送信部調整 (1)

調整項目	調整時の条件	ユニット	測定箇所	調整値	ユニット	調整箇所
トータル ゲイン調整	1 <ul style="list-style-type: none"> 表示周波数 : 145.0000 MHz MODE : USB MIC GAIN ツマミ: 中央 AGをMICROPHONEコネクタ-に接続する。 レベル : 2 mV/1.5 kHz 送信状態にする。 	MAIN	J3またはJ4に高周波電圧計を接続する。	最大	MAIN	L1, L2
				- 22dBm		
	3 <ul style="list-style-type: none"> R39 (CTRL UNIT) をシャーシにア-スする。 AGをMICROPHONEコネクタ-に接続する。 レベル : 2 mV/1.5 kHz 送信状態にする。 	後面 パネル	144MHz帯用アンテナコネクタ-にパワ-計を接続する。	最大	RF-A	L1
				6 W (IC-970) 13 W (IC-970M) 18 W (IC-970D)		R2
	5 <ul style="list-style-type: none"> 表示周波数 : 435.0000 MHz MODE : USB R39 (CTRL UNIT) をシャーシにア-スする。 AGをMICROPHONEコネクタ-に接続する。 レベル : 2 mV/1.5 kHz 送信状態にする。 	後面 パネル	430MHz帯用アンテナコネクタ-にパワ-計を接続する。	最大	RF-B	L1~L7 L47
				6 W (IC-970) 13 W (IC-970M) 16 W (IC-970D)		R82
	7	注意 : 調整が完了すればR39を元通りにしておく。				
送信パワ- 調整	1 <ul style="list-style-type: none"> 表示周波数 : 146.0000 MHz MODE : USB MIC GAIN ツマミ: 中央 RF PWR ツマミ: 右一杯 AGをMICROPHONEコネクタ-に接続する。 レベル : 20mV/1.5 kHz 送信状態にする。 	MAIN	J17, pin 5に直流電圧計を接続する。	3.0 V	MAIN	R118
				10 W (IC-970) 25 W (IC-970M) 35 W (IC-970D)		CTRL
	3 <ul style="list-style-type: none"> 表示周波数 : 440.0000 MHz MODE : USB MIC GAIN ツマミ: 中央 RF PWR ツマミ: 右一杯 AGをMICROPHONEコネクタ-に接続する。 レベル : 20mV/1.5 kHz 送信状態にする。 	後面 パネル	430MHz帯用アンテナコネクタ-にパワ-計を接続する。	10 W (IC-970) 25 W (IC-970M) 30 W (IC-970D)		R14

• MAIN, RF-A, RF-B UNIT

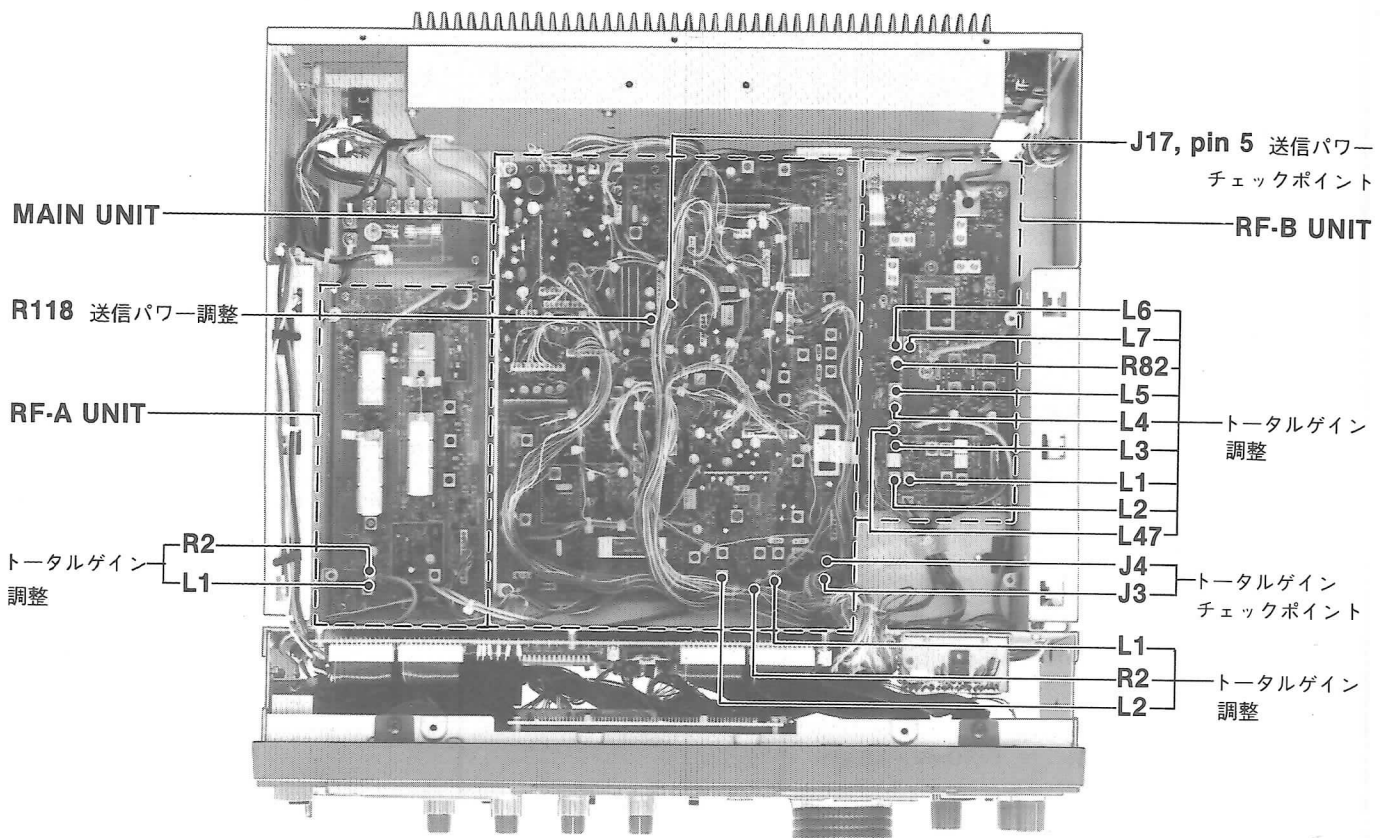

• CTRL UNIT

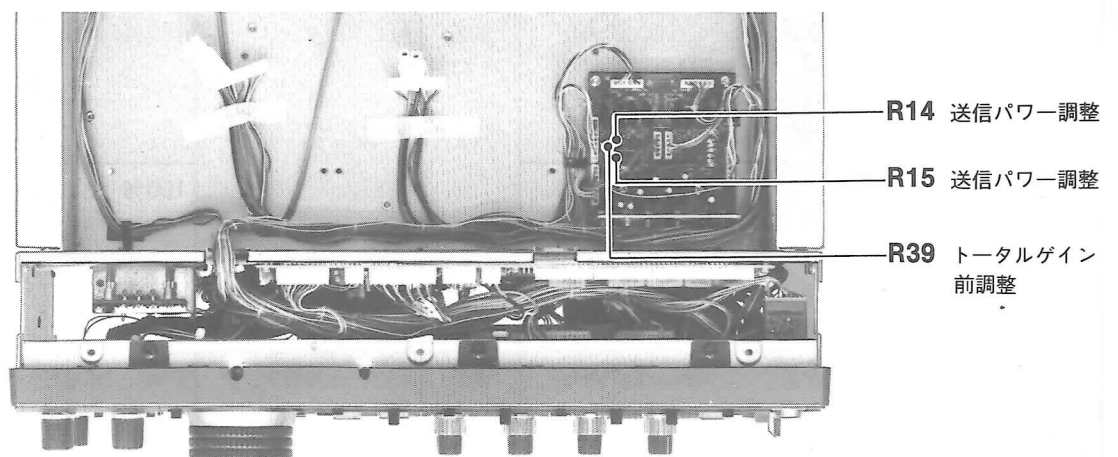

送信部調整 (2)

調整項目	調整時の条件	ユニット	測定箇所	調整値	ユニット	調整箇所
RF メーター調整	1 <ul style="list-style-type: none"> 表示周波数 : 440.0000 MHz MODE : USB MIC GAIN ツマミ: 中央 RF PWR ツマミ: 右一杯 S・RF/C・ALC スイッチ : S・RF 430MHz 帯用アンテナコネクタにパワー計を接続する。 AG を MICROPHONE コネクタに接続する。 レベル : 20mV/1.5 kHz 送信状態にする。 	前面 パネル	RF メーター	90 % 	MAIN	R378
ALC メーター調整	1 <ul style="list-style-type: none"> 表示周波数 : 435.0000 MHz MODE : USB MIC GAIN ツマミ: 中央 RF PWR ツマミ: 右一杯 S・RF/C・ALC スイッチ : C・ALC 430MHz 帯用アンテナコネクタにパワー計を接続する。 AG を MICROPHONE コネクタに接続する。 レベル : 10mV/1.5 kHz 送信状態にする。 	前面 パネル	ALC メーター	100 % 	MAIN	R121
FM パワー 調整 (IC-970D のみ)	1 <ul style="list-style-type: none"> 表示周波数 : 440.0000 MHz MODE : FM RF PWR ツマミ: 右一杯 送信状態にする。 	後面 パネル	430MHz 帯用アンテナコネクタにパワー計を接続する。	40 W	MAIN	R380
	2 <ul style="list-style-type: none"> 表示周波数 : 144.0000 MHz 送信状態にする。 		144MHz 帯用アンテナコネクタにパワー計を接続する。	46~50 W		確認
FM/CW ドライブレベル調整	1 <ul style="list-style-type: none"> 表示周波数 : 435.0000 MHz MODE : FM RF PWR ツマミ: 右一杯 送信状態にする。 	前面 パネル	ALC メーター	100 %	MAIN	R44
	2 <ul style="list-style-type: none"> MODE : CW RF PWR ツマミ: 右一杯 KEY ジャックにキーをつなぎキーダウンする。 送信状態にする。 			100 %		R104
430MHz ローパワー調整	1 <ul style="list-style-type: none"> 表示周波数 : 435.0000 MHz MODE : FM RF PWR ツマミ: 左一杯 送信状態にする。 	後面 パネル	430MHz 帯用アンテナコネクタにパワー計を接続する。	1 W (IC-970) 3.5 W (IC-970M) 6.0 W (IC-970D)	MAIN	R120
	2			上記の調整の後、ハイパワーの確認をおこなってください。		

送信部調整 (3)

調整項目	調整時の条件	ユニット	測定箇所	調整値	ユニット	調整箇所
144MHz ローパワー 調整	1 <ul style="list-style-type: none"> 表示周波数 : 145.0000 MHz MODE : FM RF PWR ツマミ : 左一杯 送信状態にする。 	後面 パネル	144MHz 帯用アンテナコネクタにパワー計を接続する。	0.5~1.5 W (IC-970) 2.0~3.0 W (IC-970M) 4.0~5.0 W (IC-970D)		確認

• MAIN UNIT

R380 FM パワー調整 (IC-970D のみ)

R120 430MHz ローパワー調整

R378 RF メーター調整

R121 ALC メーター調整

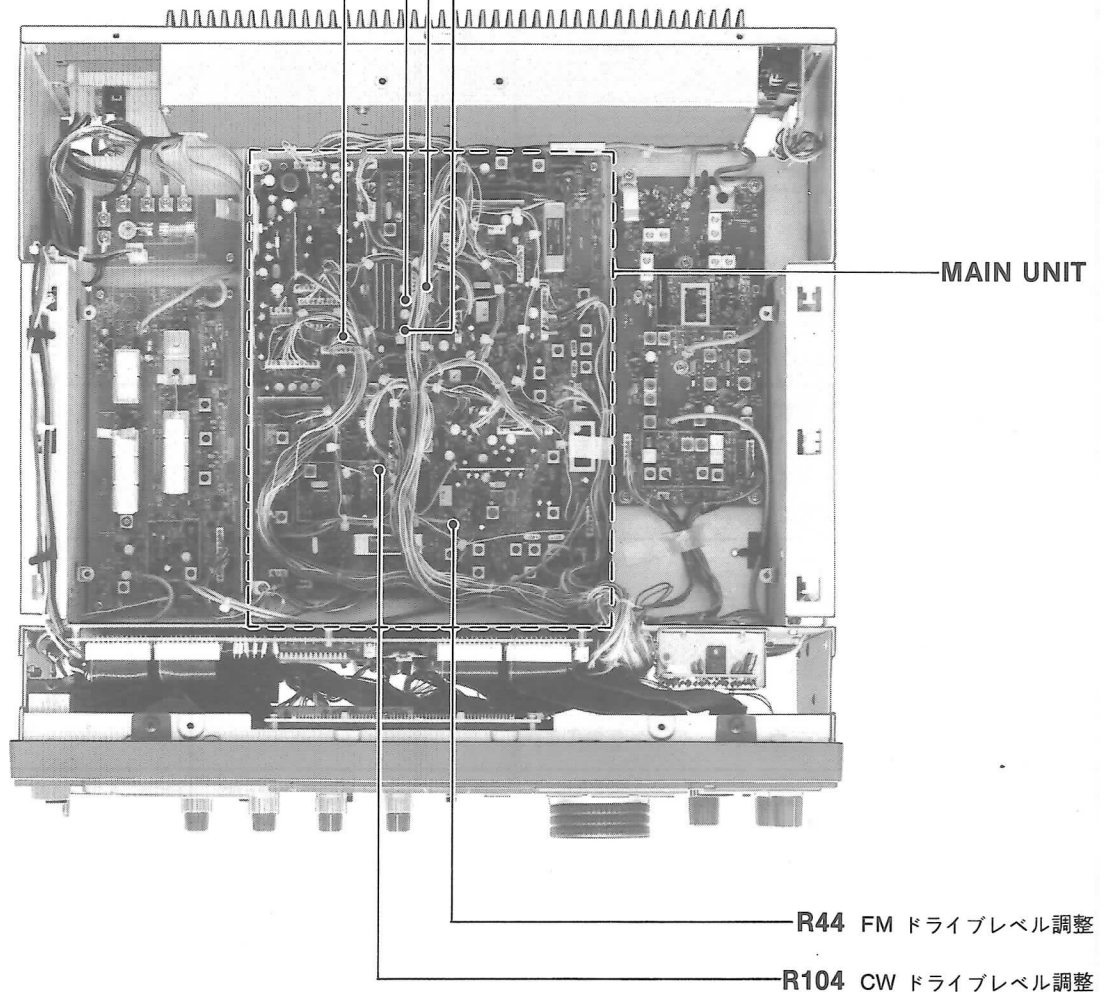

R44 FM ドライブレベル調整

R104 CW ドライブレベル調整

送信部調整 (4)

調整項目	調整時の条件	ユニット	測定箇所	調整値	ユニット	調整箇所	
IC APC- メーター調整	この調整は、バージョンによって異なります。以下のプリセットをおこなったのちそれぞれの調整を始めてください。						
	<ul style="list-style-type: none"> •表示周波数 : 145.0000 MHz •MODE : USB •MIC GAIN ツマミ: 右一杯 •RF PWR ツマミ: 右一杯 •S・RF/C・ALC スイッチ : C・ALC •R39 (CTRL UNIT) のリードをアースに落とす。 •AG を MICROPHONE コネクタに接続する。 レベル : 20mV/1.5 kHz 						
IC-970	1	•送信状態にする。	後面 パネル	144MHz 帯用アンテナコネクタにパワー計を接続する。	15 W	MAIN	R117
	2	<ul style="list-style-type: none"> •表示周波数 : 435.0000 MHz •送信状態にする。 		430MHz 帯用アンテナコネクタにパワー計を接続する。			R116
IC-970M	1	<ul style="list-style-type: none"> •外部電源の電圧を 11.7V まで下げる。 •144MHz 帯用アンテナコネクタにパワー計を接続する。 •送信状態にする。 	前面 パネル	ALCメーター	ALCメーターの針が振れ始める位置に調整する。	MAIN	R117
	2	<ul style="list-style-type: none"> •表示周波数 : 435.0000 MHz •430MHz 帯用アンテナコネクタにパワー計を接続する。 •送信状態にする。 					R116
IC-970D	1	•送信状態にする。	後面 パネル	外部電源と本体の間に電流計を接続する。	12 A	MAIN	R117
	2	<ul style="list-style-type: none"> •表示周波数 : 435.0000 MHz •430MHz 帯用アンテナコネクタにパワー計を接続する。 •送信状態にする。 			16 A		R116
HTP調整 (IC-970は除く)	1	<ul style="list-style-type: none"> •表示周波数 : 145.0000 MHz •MODE : FM •RF PWR ツマミ: 右一杯 •送信状態にする。 •J17, pin3 (MAIN UNIT) に4.7 kΩの抵抗を通して8~13.8Vを加える。 	後面 パネル	144MHz 帯用アンテナコネクタにパワー計を接続する。	12.5 W (IC - 970M) 22.5 W (IC - 970D)	MAIN	R114
パワー バランス調整	1	<ul style="list-style-type: none"> •表示周波数 : 145.0000 MHz •MODE : USB / LSB •AG を MICROPHONE コネクタに接続する。 レベル : 2 mV/300 Hz •送信状態にする。 	後面 パネル	144MHz 帯用アンテナコネクタにパワー計を接続する。	USB、LSBとも同じになるように調整する。	MAIN	C76

• MAIN UNIT

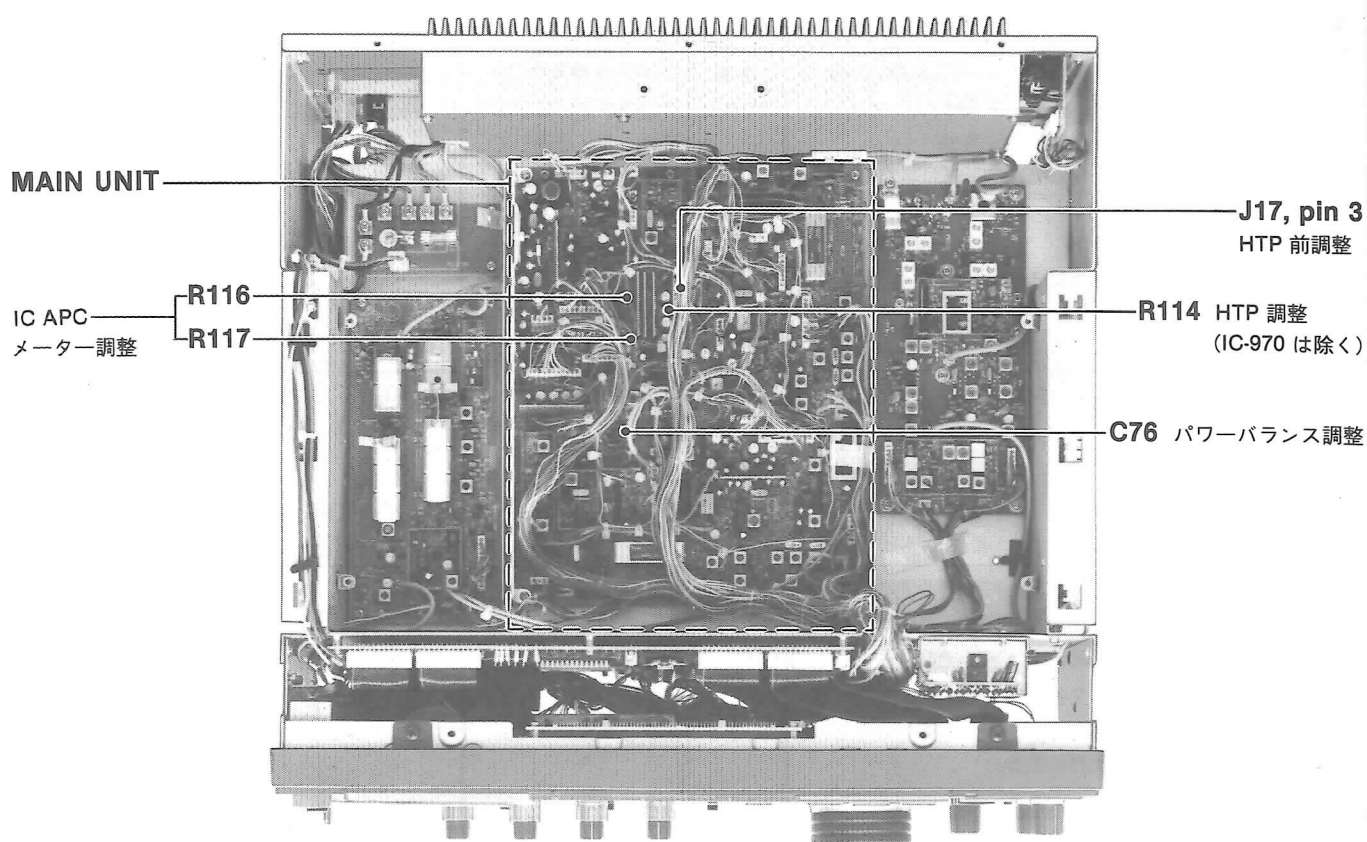

• CTRL UNIT

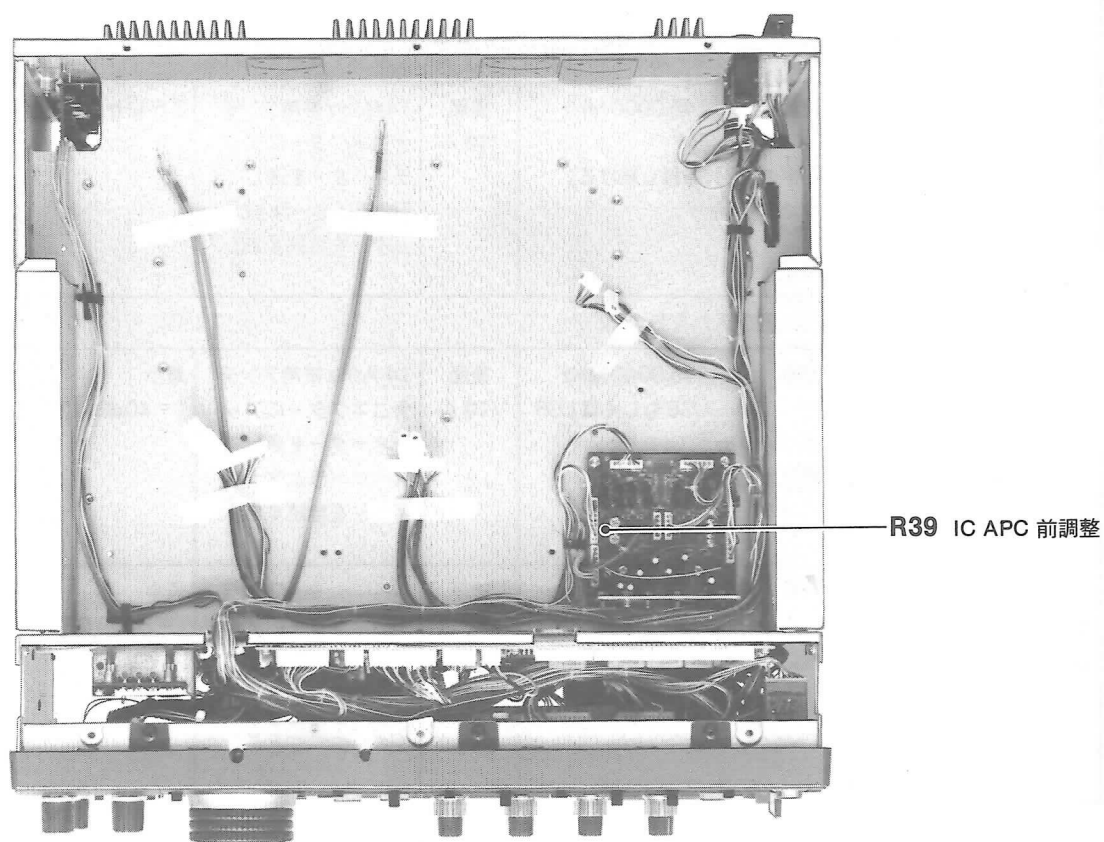

送信部調整 (5)

調整項目	調整時の条件	ユニット	測定箇所	調整値	ユニット	調整箇所
デビュ－ション調整	1 <ul style="list-style-type: none"> 表示周波数 : 145.0000 MHz MODE : FM MIC GAIN ツマミ: 中央 AGをMICROPHONEコネクタ－に接続する。 レベル : 20mV/1 kHz 送信状態にする。 	後面 パネル	144MHz 帯用アンテナコネクタ－にアンテナネ－タ－を通してFMデビュ－ションメ－タ－を接続する。	4.8 kHz	MAIN	R28
	2 <ul style="list-style-type: none"> MICROPHONE入力を次のようにする。 レベル : 2 mV/1 kHz 					
サブオーディブルトーン調整	1 <ul style="list-style-type: none"> 表示周波数 : 430.0000 MHz MODE : FM MICROPHONE入力: OFF TONE スイッチ : ON トーン周波数 : 67Hz 送信状態にする。 	後面 パネル	430MHz 帯用アンテナコネクタ－にアンテナネ－タ－を通してFMデビュ－ションメ－タ－を接続する。	0.5 kHz	MAIN	R65
トーンスケルチ調整 (UT-34を組こんでいること。)	1 <ul style="list-style-type: none"> 表示周波数 : 145.0000 MHz MODE : FM MICROPHONE入力: OFF トーンスケルチ : ON トーン周波数 : 67Hz 送信状態にする。 	後面 パネル	144MHz 帯用アンテナコネクタ－にアンテナネ－タ－を通してFMデビュ－ションメ－タ－を接続する。	0.5 kHz	LOGIC	R120
DTMF調整	1	いったん電源を切りキーボードの [3] と [7] 押した状態で電源を入れる。				
	2 <ul style="list-style-type: none"> 表示周波数 : 145.0000 MHz MODE : FM キーボードの [7] を押し続ける。 送信状態にする。 	後面 パネル	144MHz 帯用アンテナコネクタ－にアンテナネ－タ－を通してFMデビュ－ションメ－タ－を接続する。	3.5 kHz	MAIN	R63
	3	電源をきり、再度入れなおす。				
キャリアサプレッション調整	1 <ul style="list-style-type: none"> 表示周波数 : 145.0000 MHz MODE : USBもしくはLSB MICROPHONE入力: OFF 送信状態にする。 	後面 パネル	144MHz 帯用アンテナコネクタ－にアンテナネ－タ－を通してスペクトラムアナライザ－を接続する。	最小 (-40dB以下)	MAIN	R85, R87
LOサプレッション調整	1 <ul style="list-style-type: none"> 表示周波数 : 145.0000 MHz MODE : FM 送信状態にする。 	後面 パネル	144MHz 帯用アンテナコネクタ－にアンテナネ－タ－を通してスペクトラムアナライザ－を接続する。	最小 (-60dB以下)	RF-A	R3, C8

• MAIN, RF-A, RF-B, LOGIC UNIT

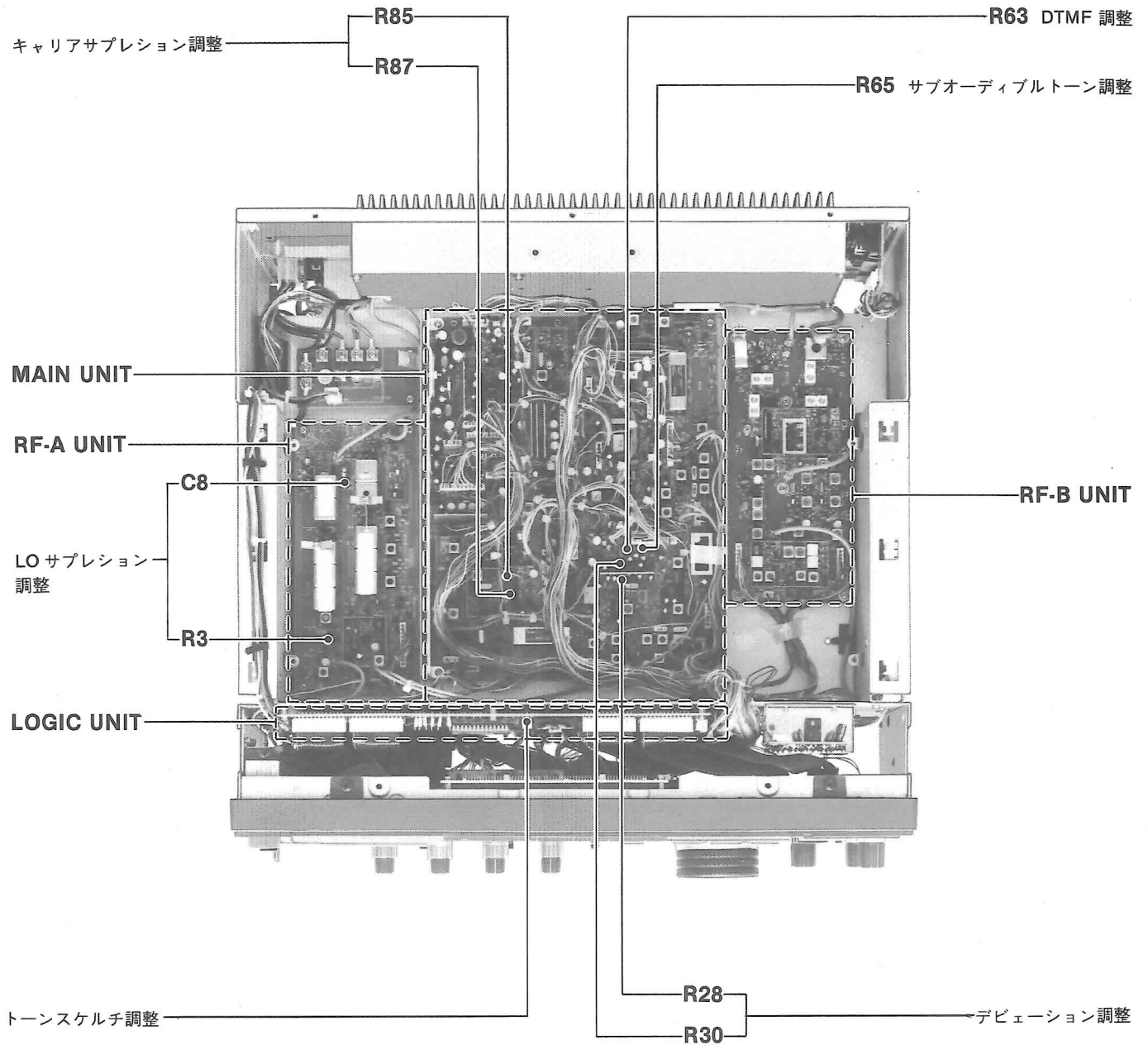

5-1 FRONT UNIT

• NOTCH UNIT

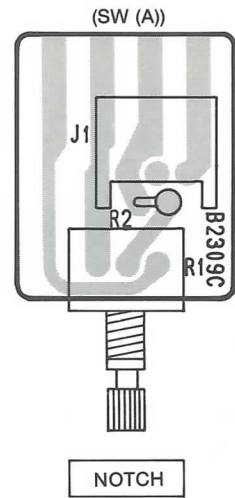

• MEMO UNIT

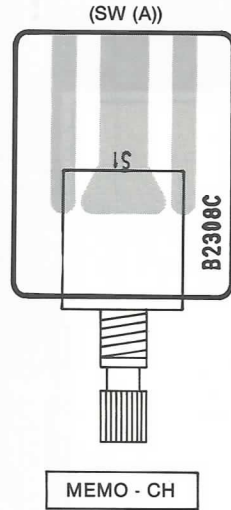

• SATE UNIT

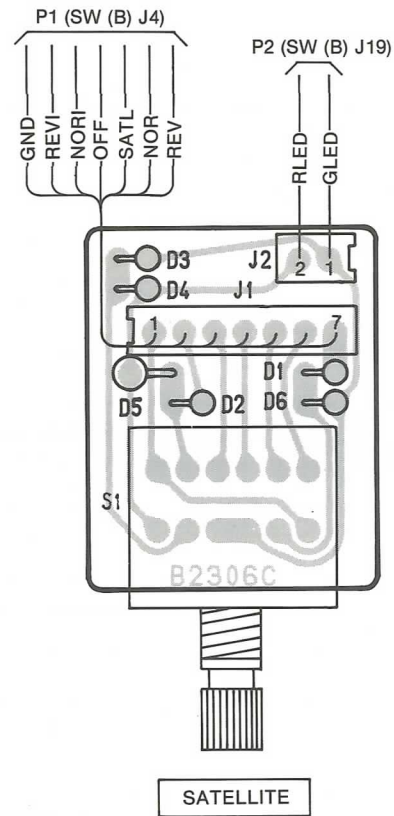

• PHONE UNIT

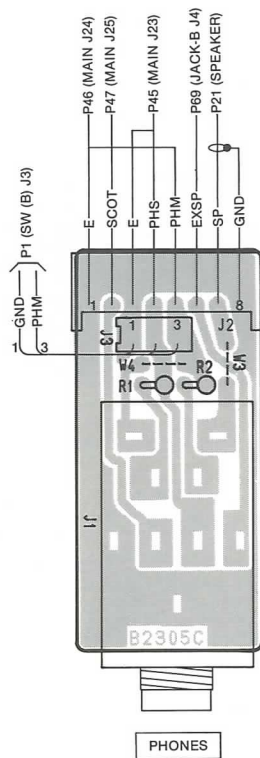

• LED UNIT

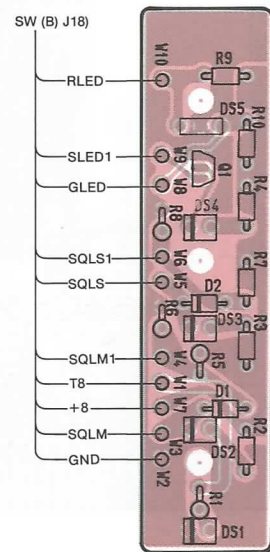

• SW (A) UNIT

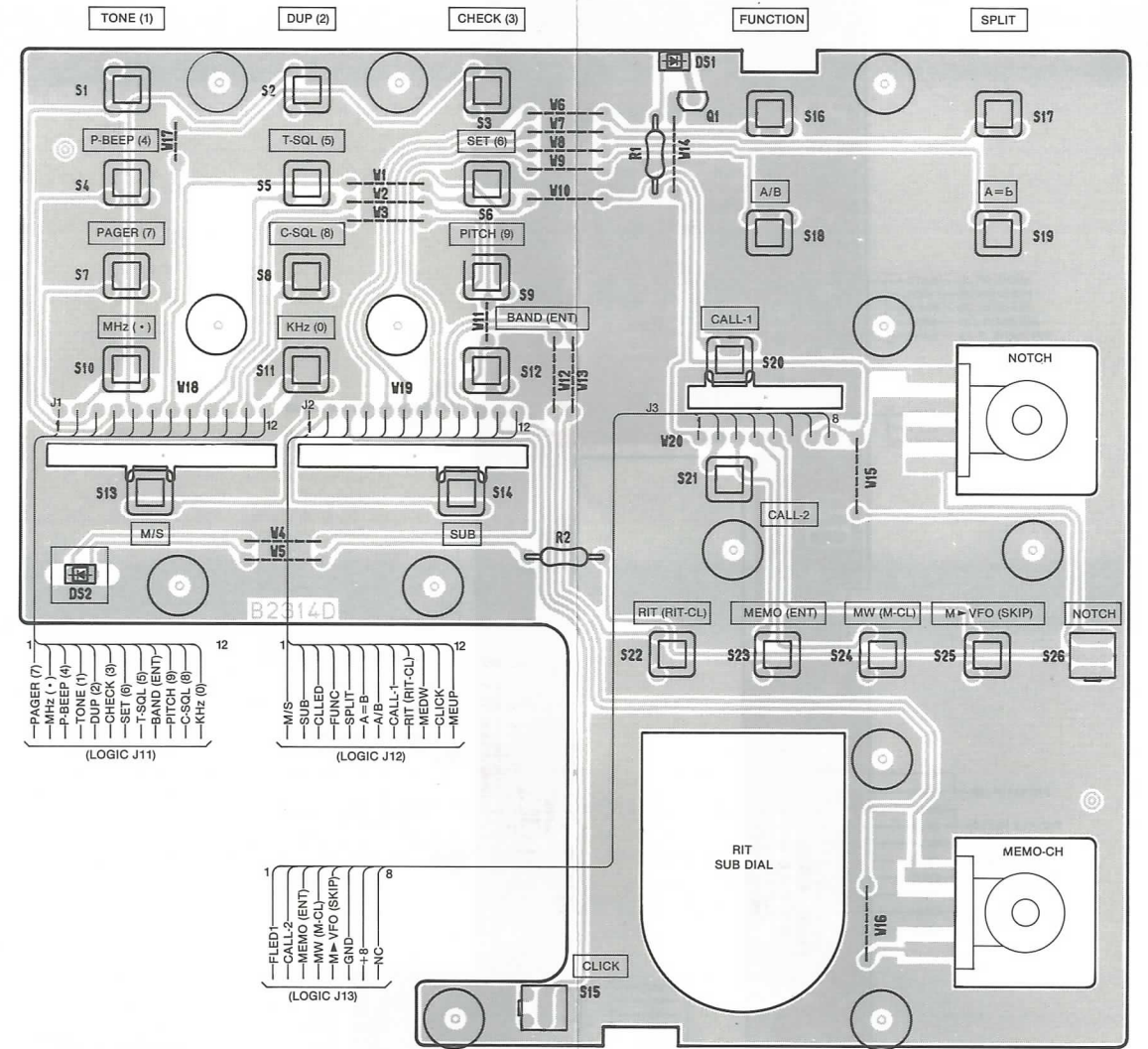

• VR UNIT

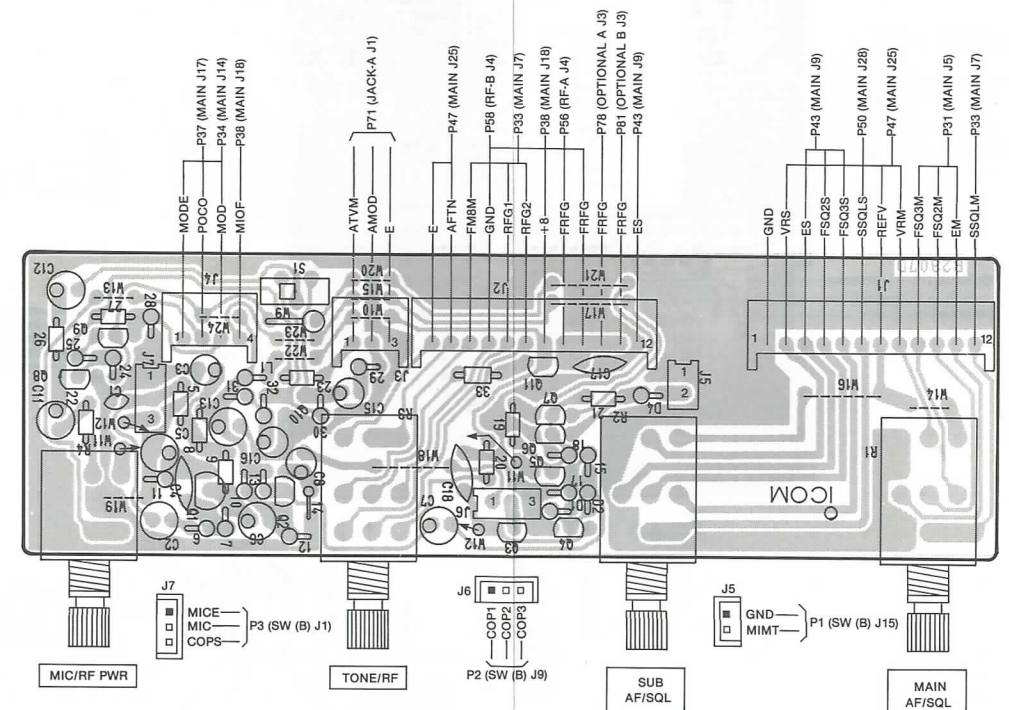

• SW (B) UNIT

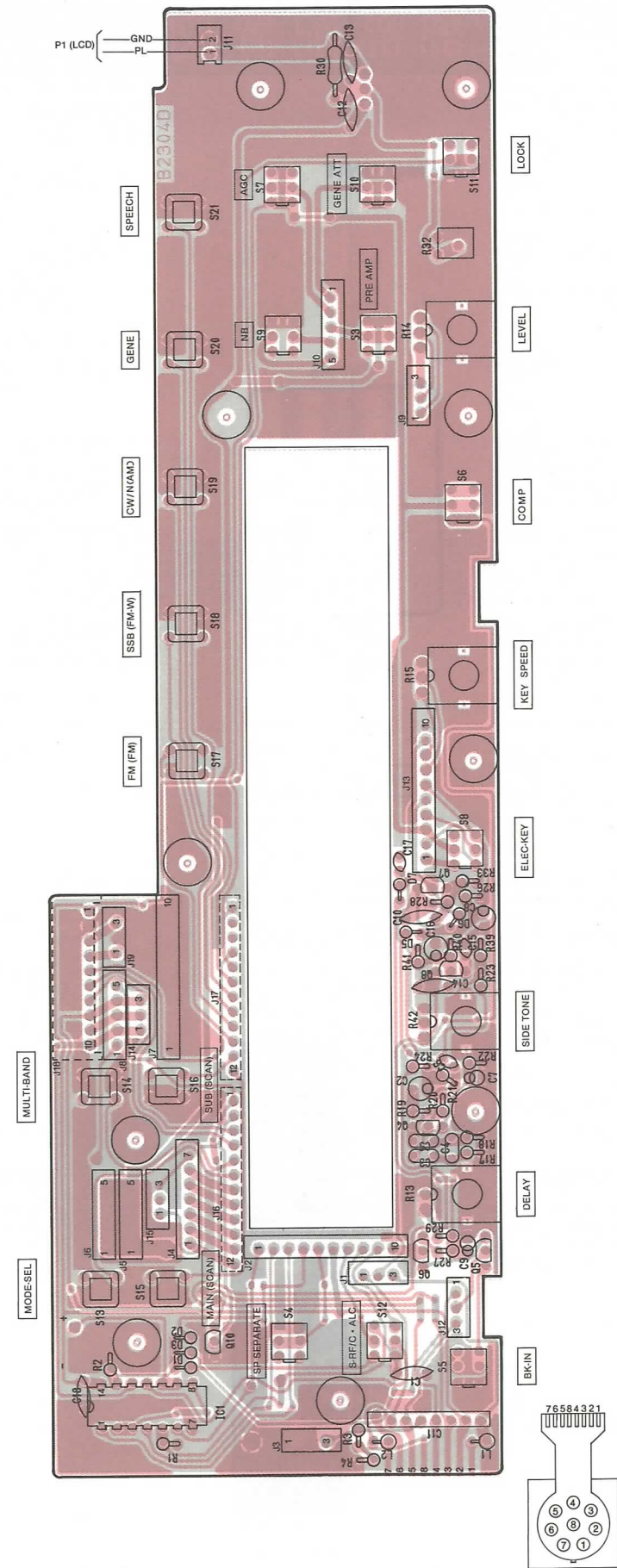
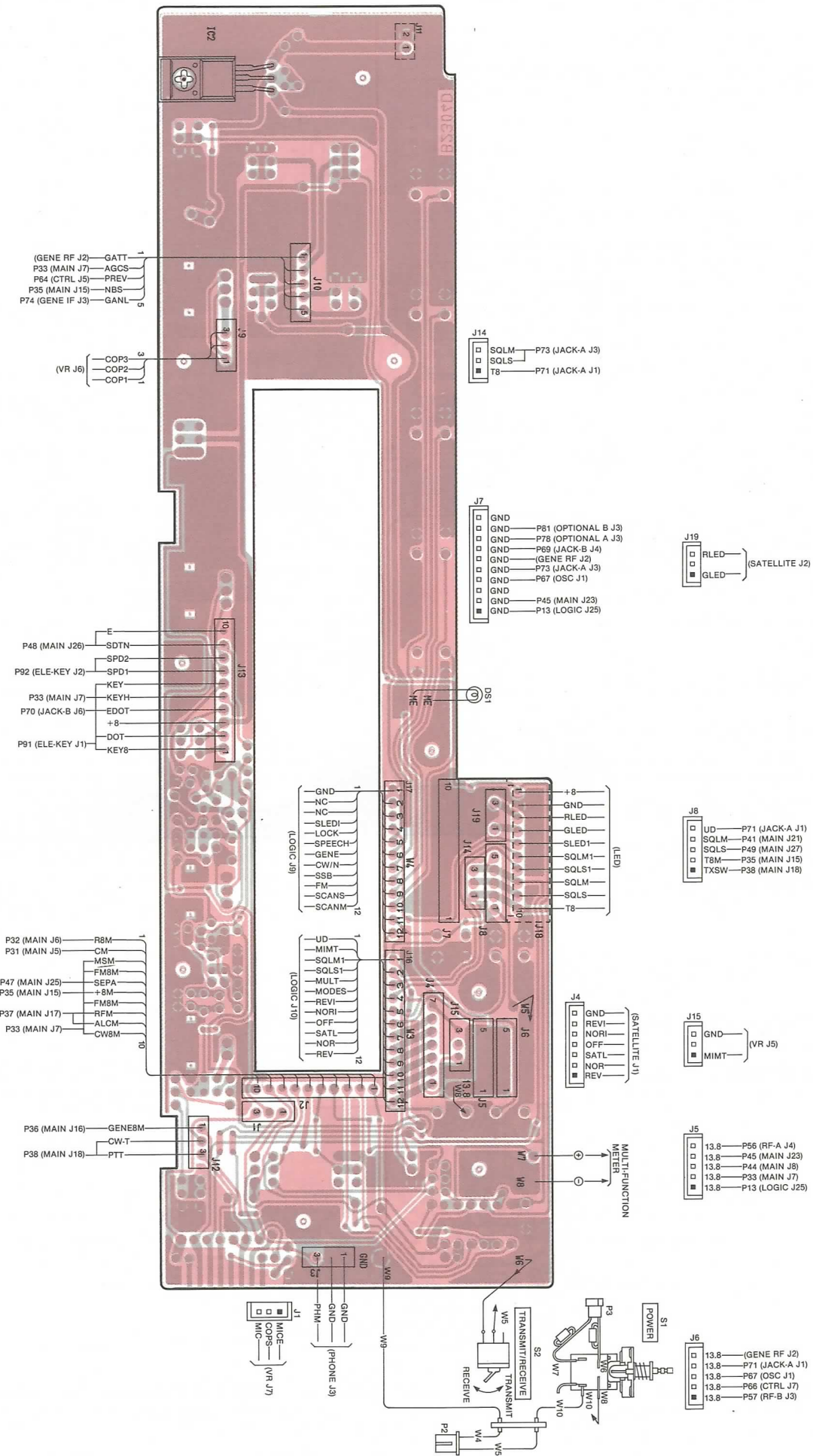

5-2 LOGIC UNIT

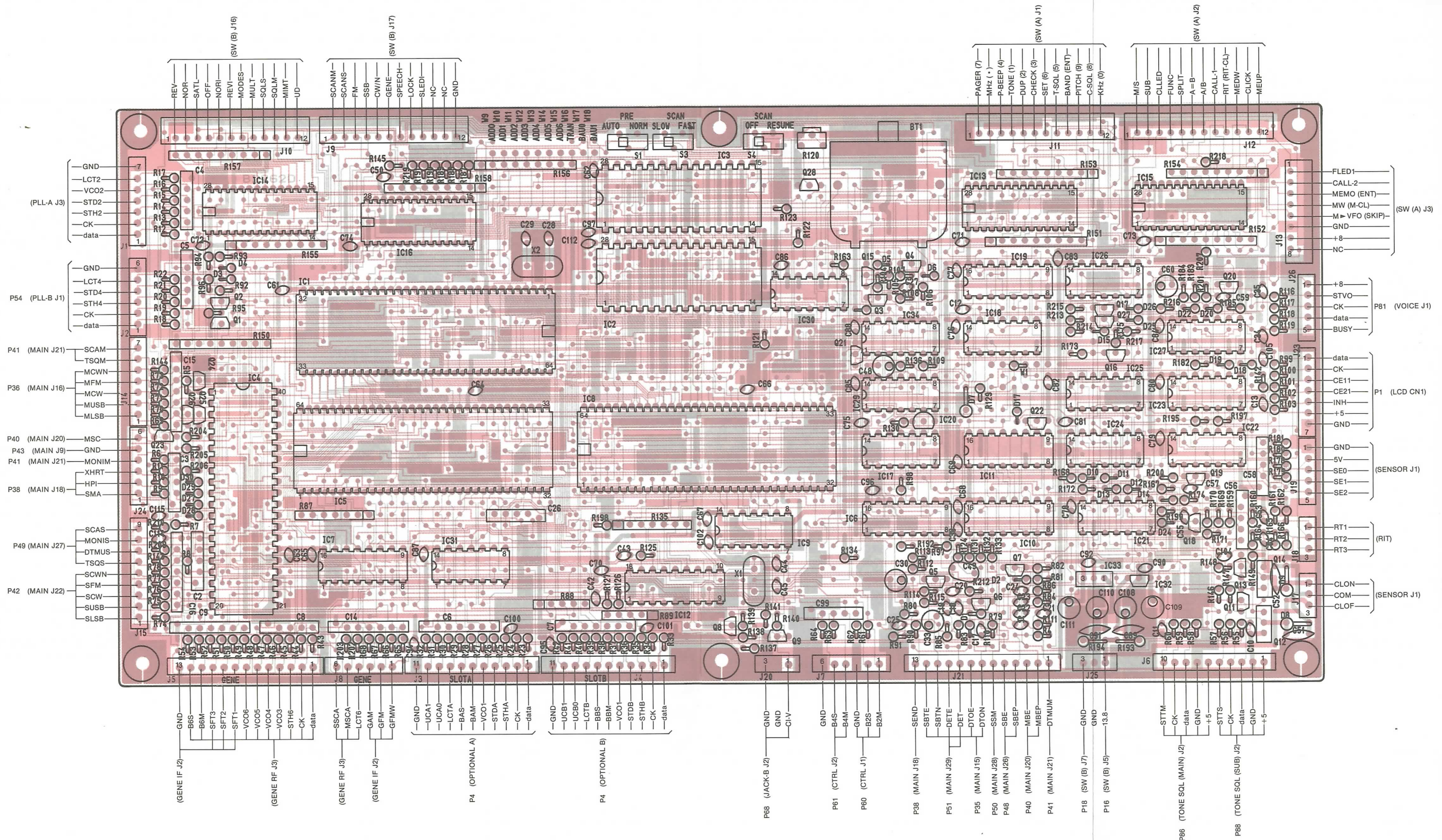

5-3 MAIN UNIT (1)

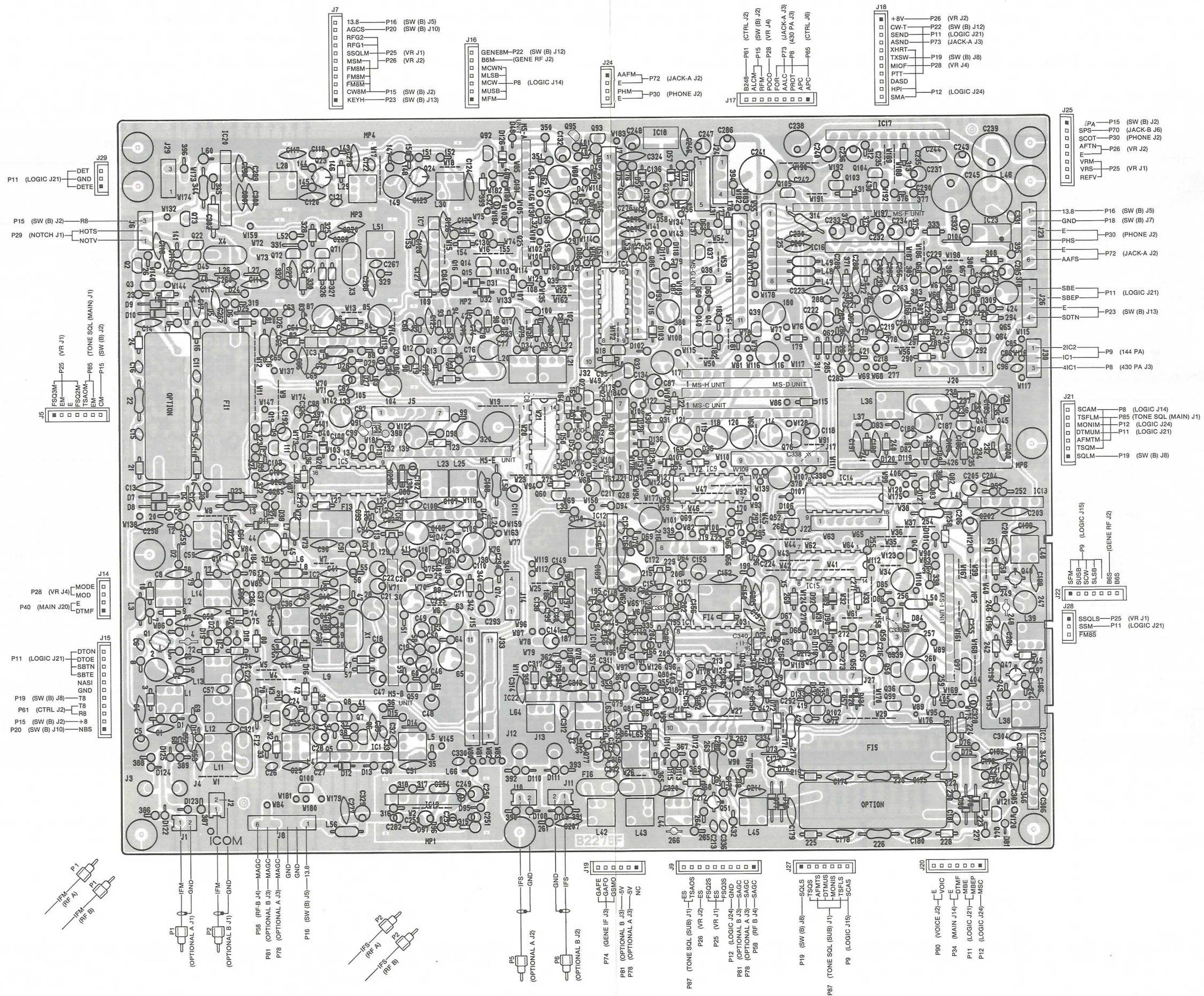

5-4 MAIN UNIT (2)

• MS-A, MS-I UNIT

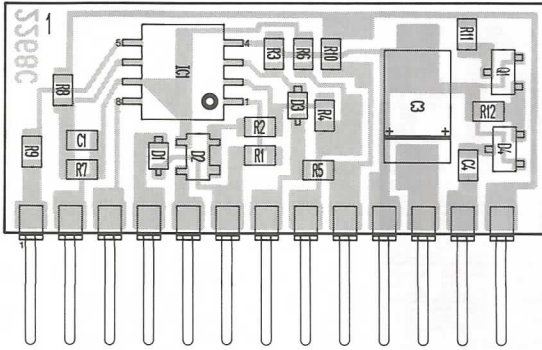

• MS-B UNIT

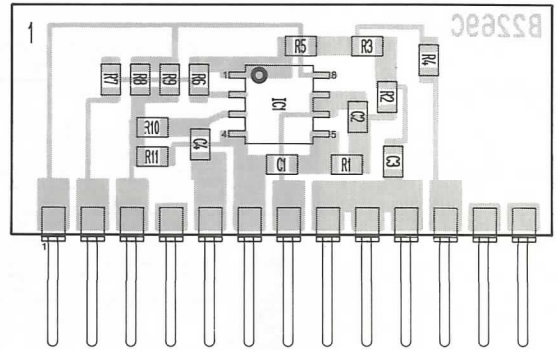

• MS-C UNIT

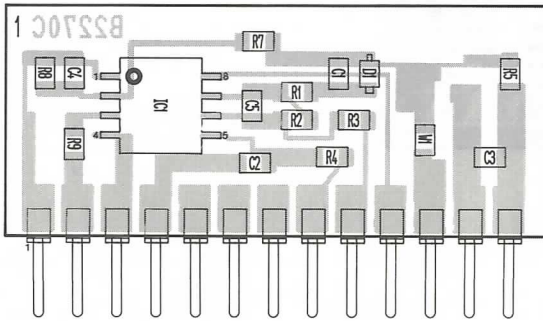

• MS-D UNIT

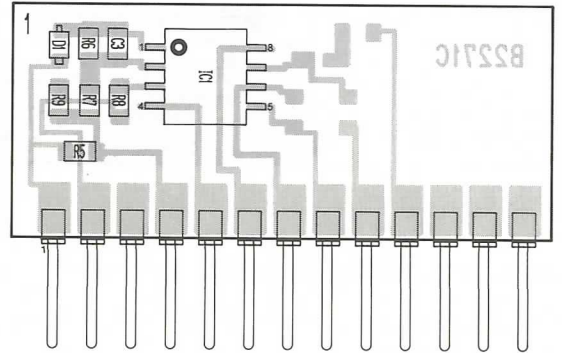

• MS-E UNIT

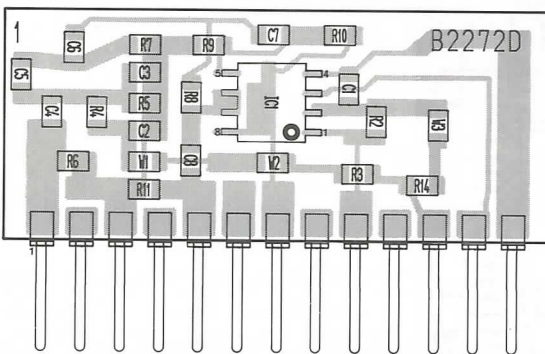

• MS-F UNIT

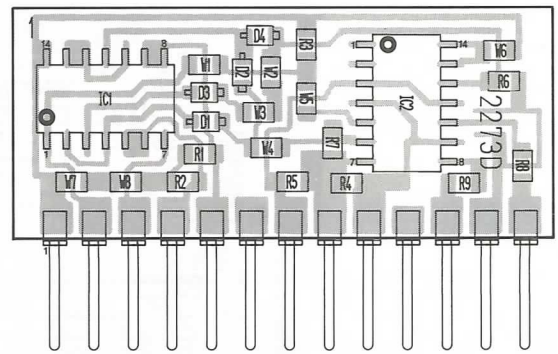

• MS-G UNIT

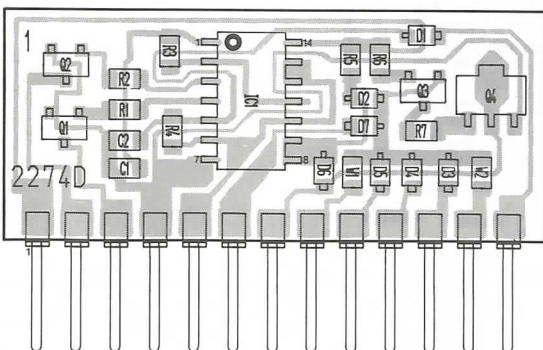

• MS-H UNIT

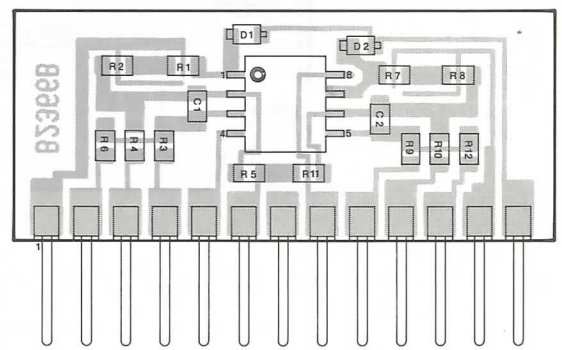

5-5 144, 430 DDS UNIT

部品面

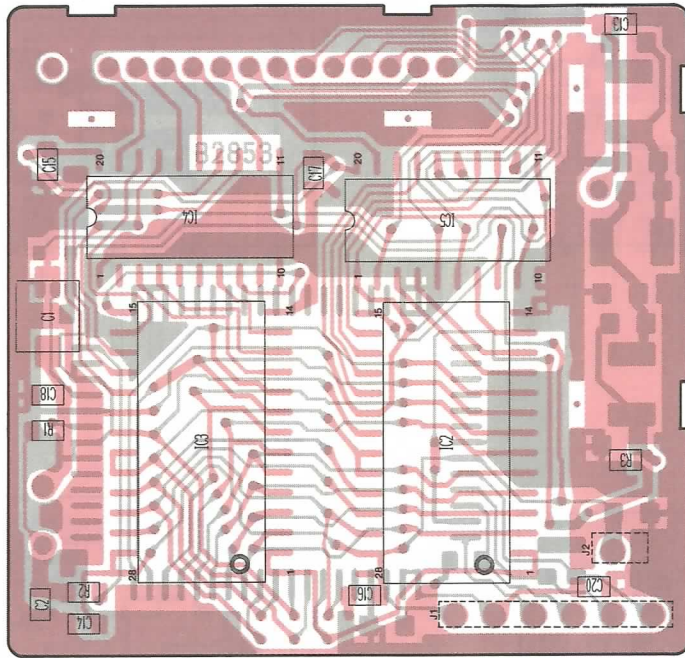

ハンダ面

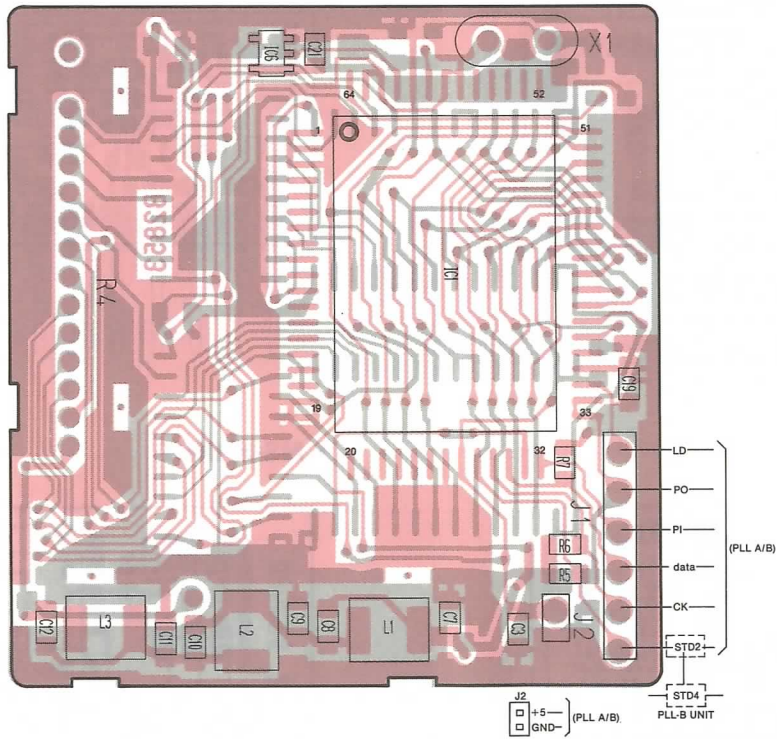

5-6 PLL-A UNIT

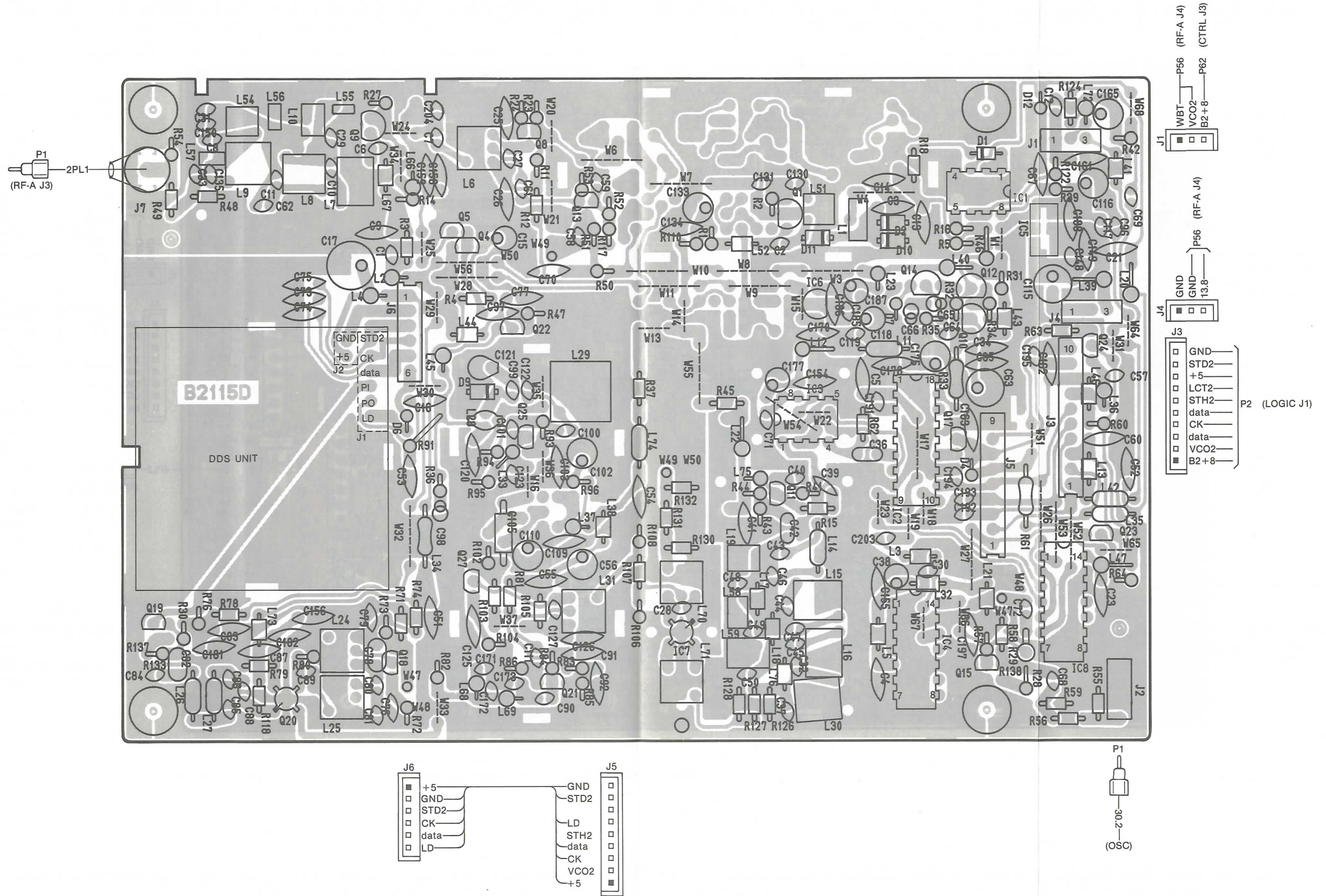

5-7 PLL-B UNIT

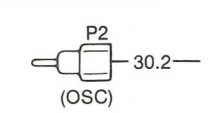
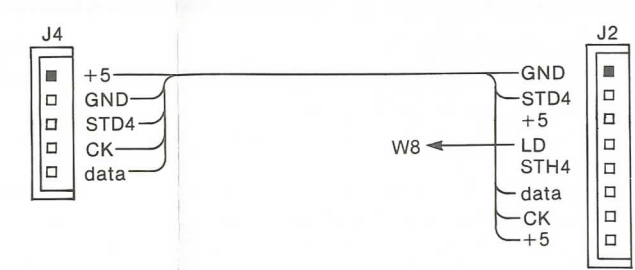
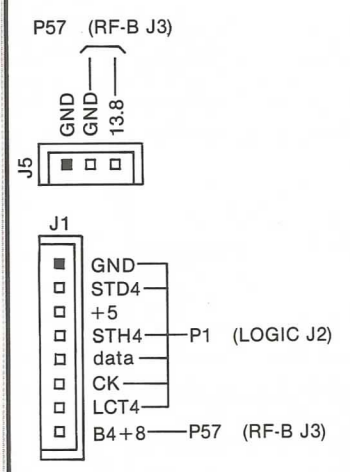
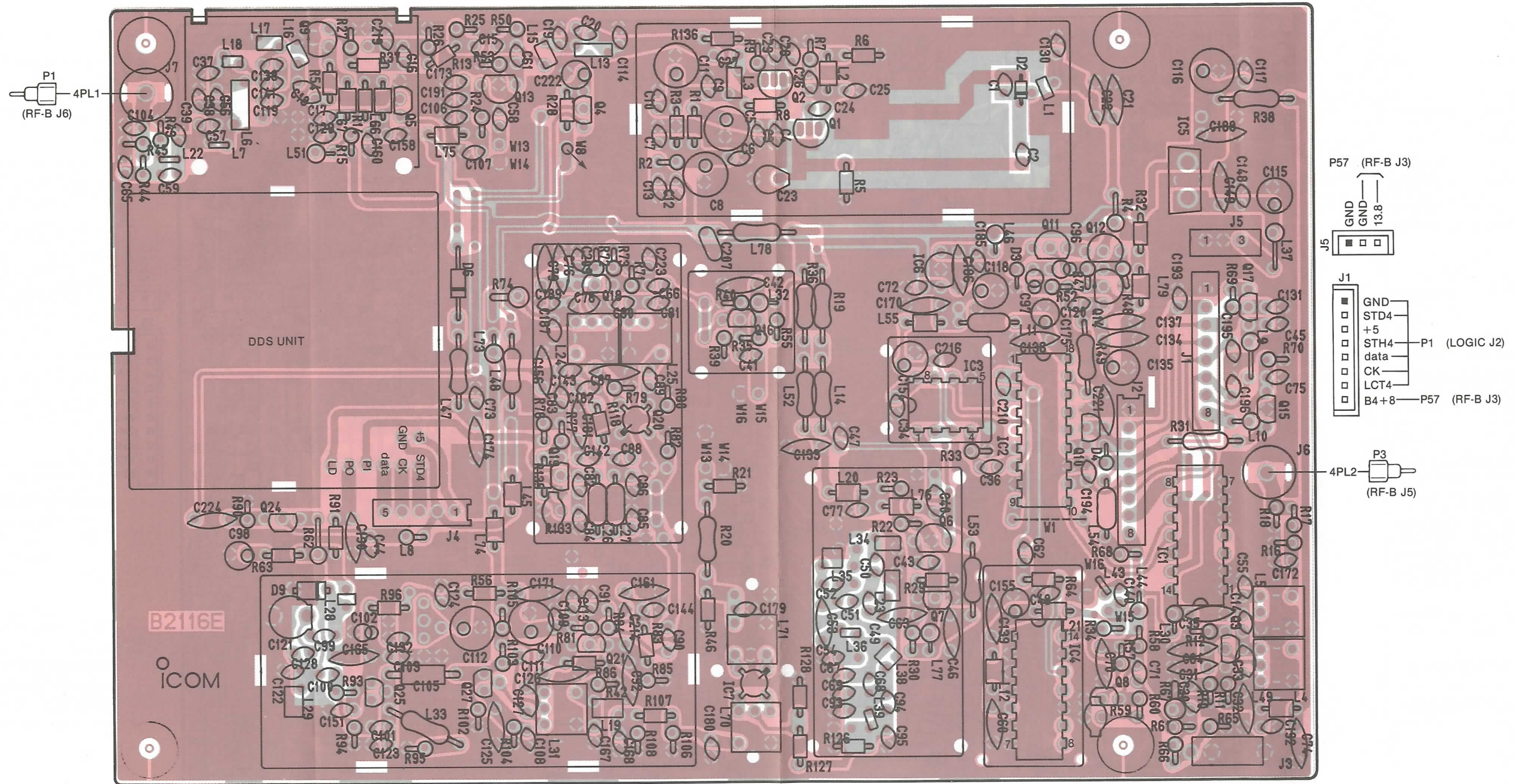

5-8 RF-A, RF-B UNIT

• RF-A UNIT

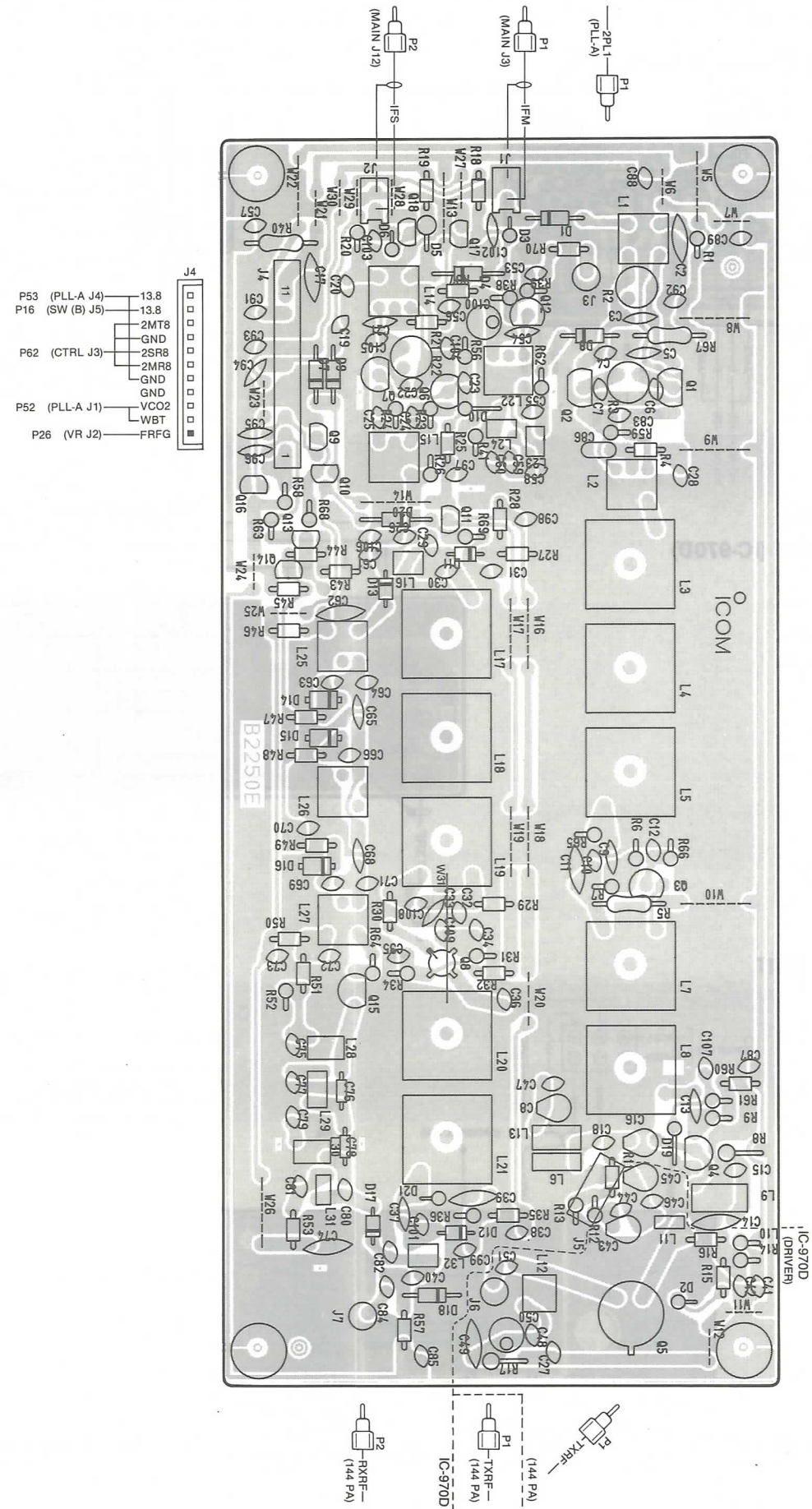

• RF-B UNIT

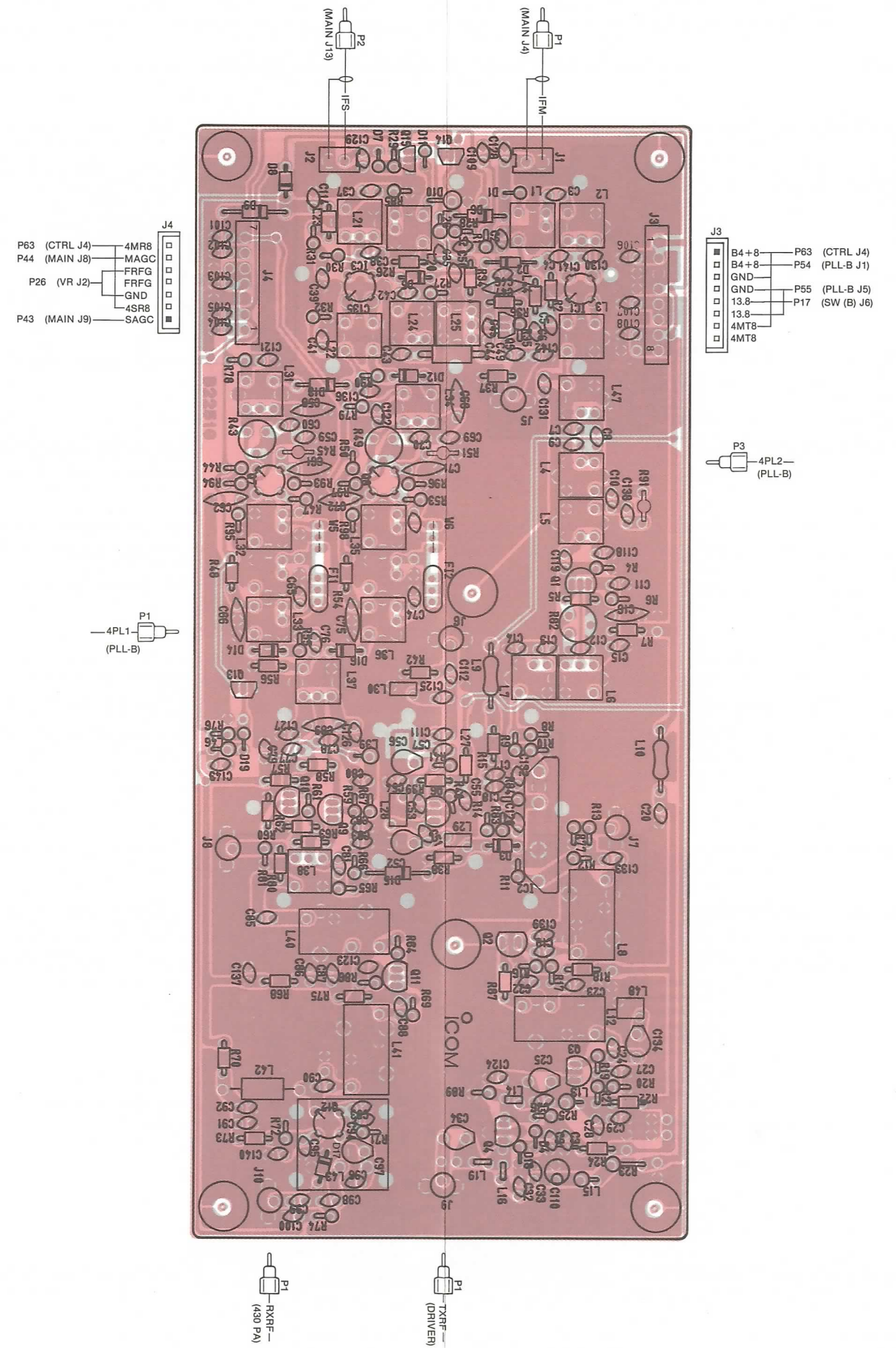

5-9 OSC, OSC (B), CTRL UNIT

• OSC UNIT

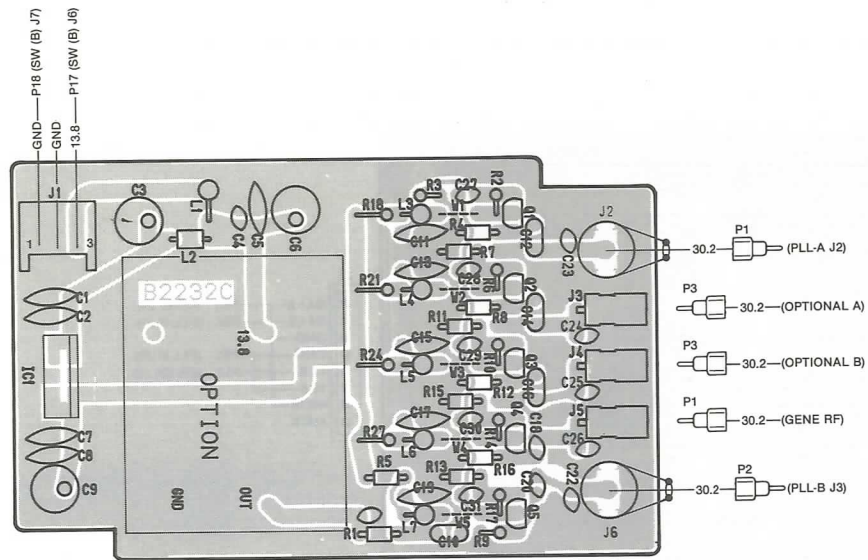

• OSC (B) UNIT

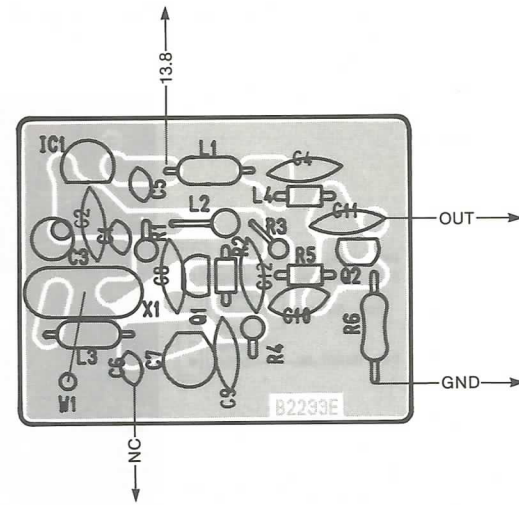

• CTRL UNIT

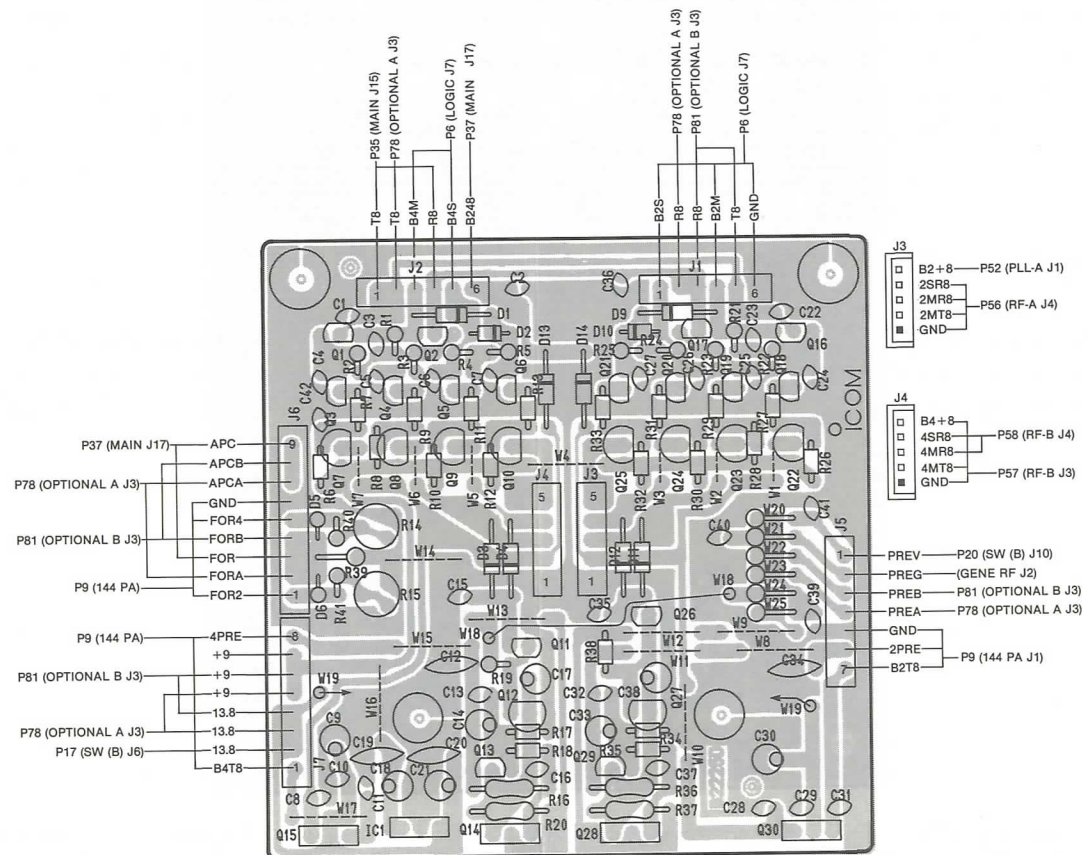

5-10 JACK-A, JACK-B, DRIVER, CONNECT UNIT

• JACK-A UNIT

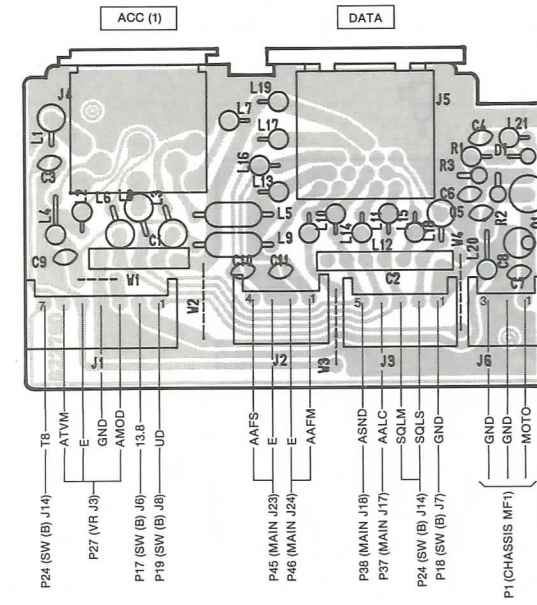

• JACK-B UNIT

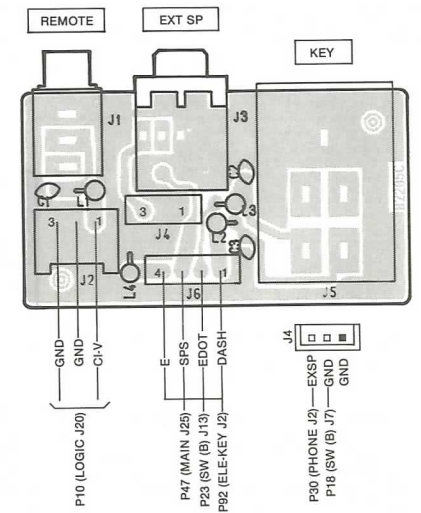

• DRIVER UNIT (IC-970D)

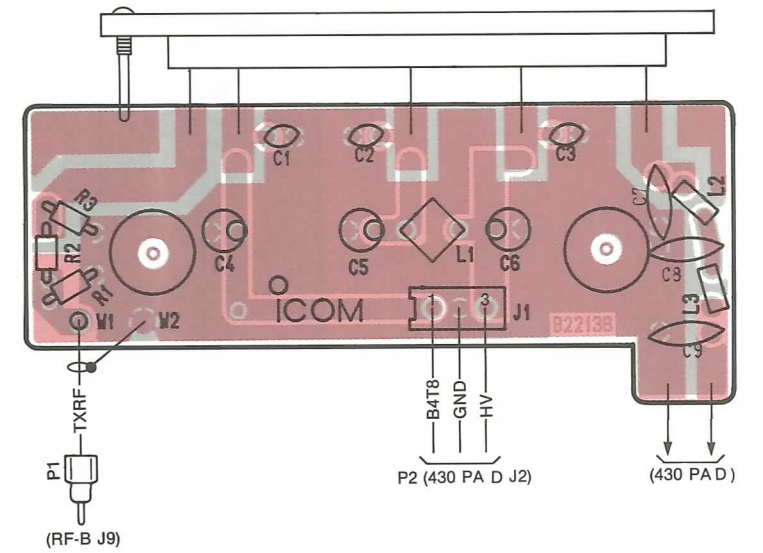

• CONNECT UNIT

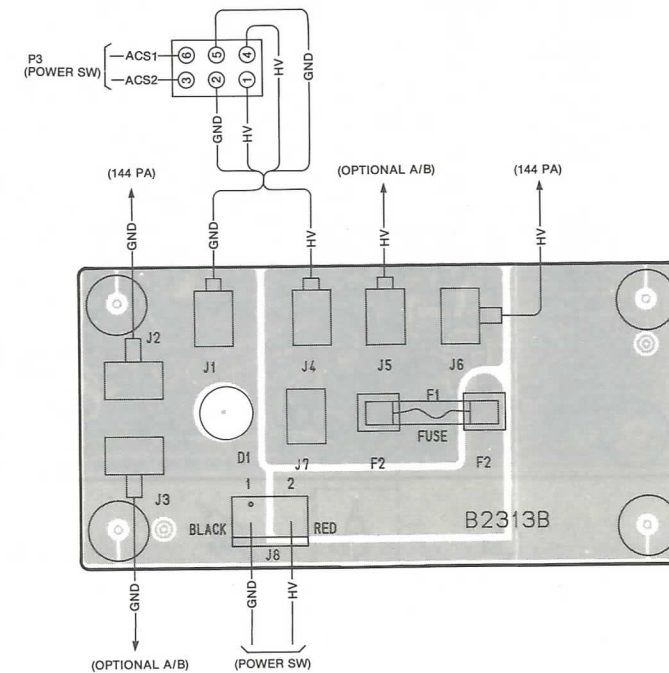

5-11 144 PA UNIT

• 144 PA H UNIT (IC-970D)

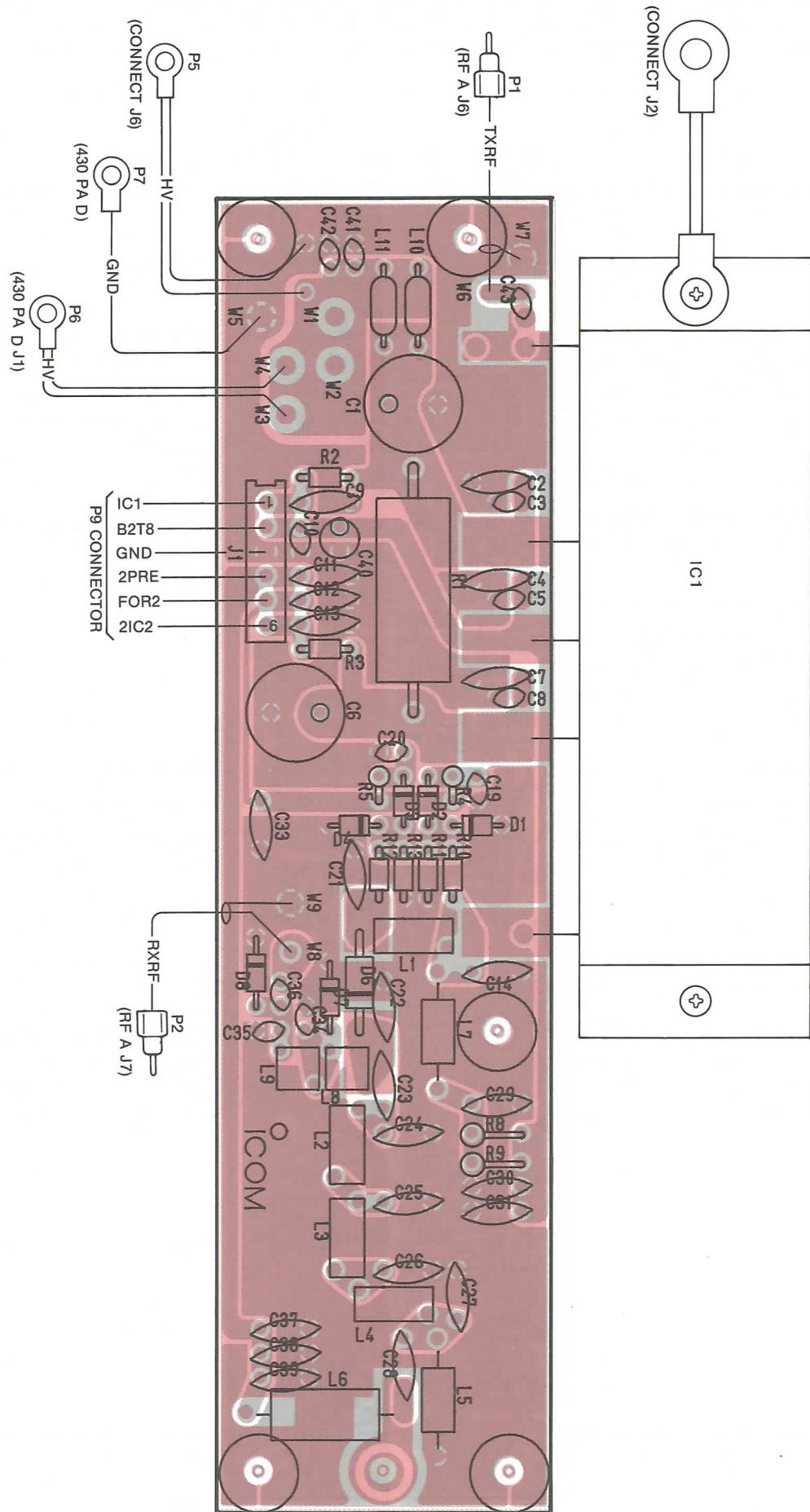

• 144 PA L UNIT (IC-970/M)

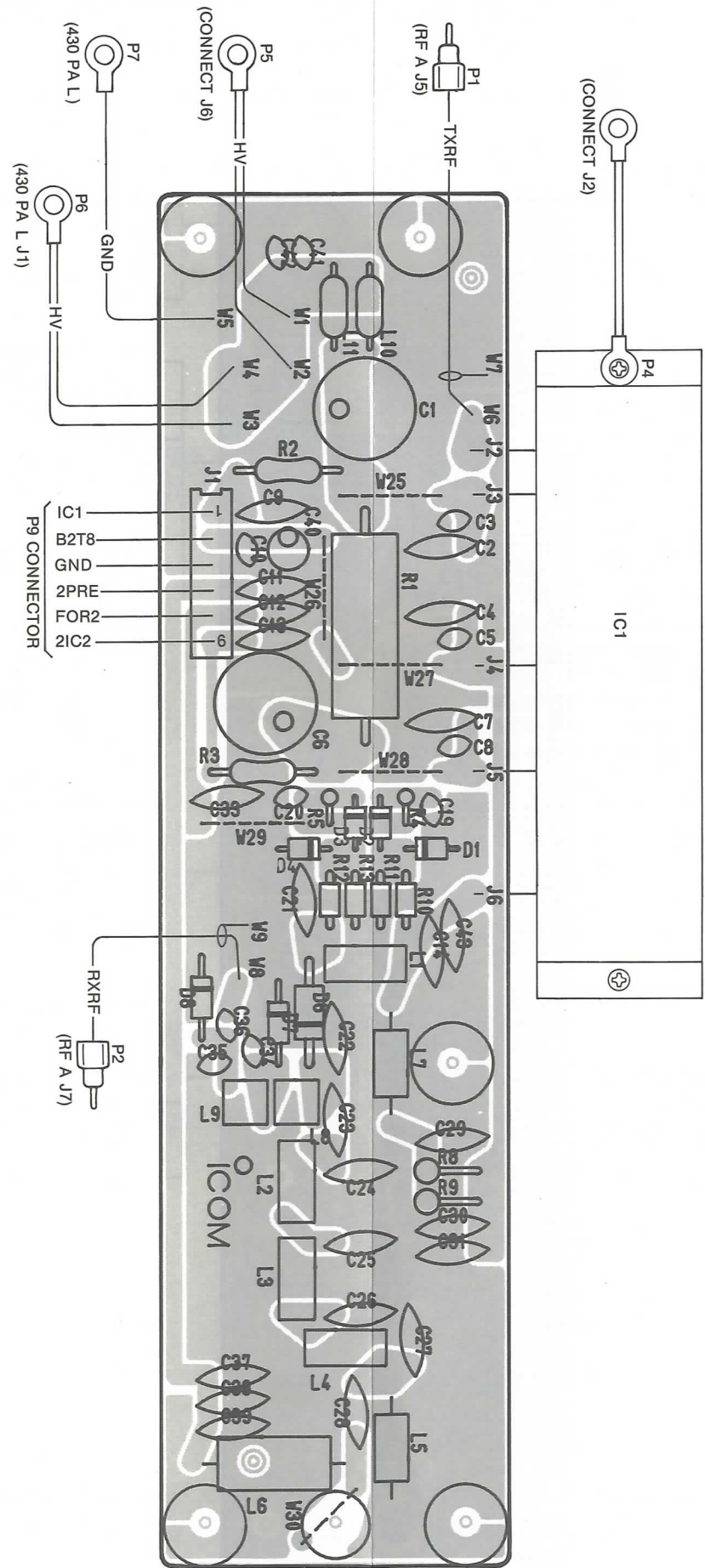

5-12 430 PA UNIT

• 430 PA H UNIT (IC-970D)

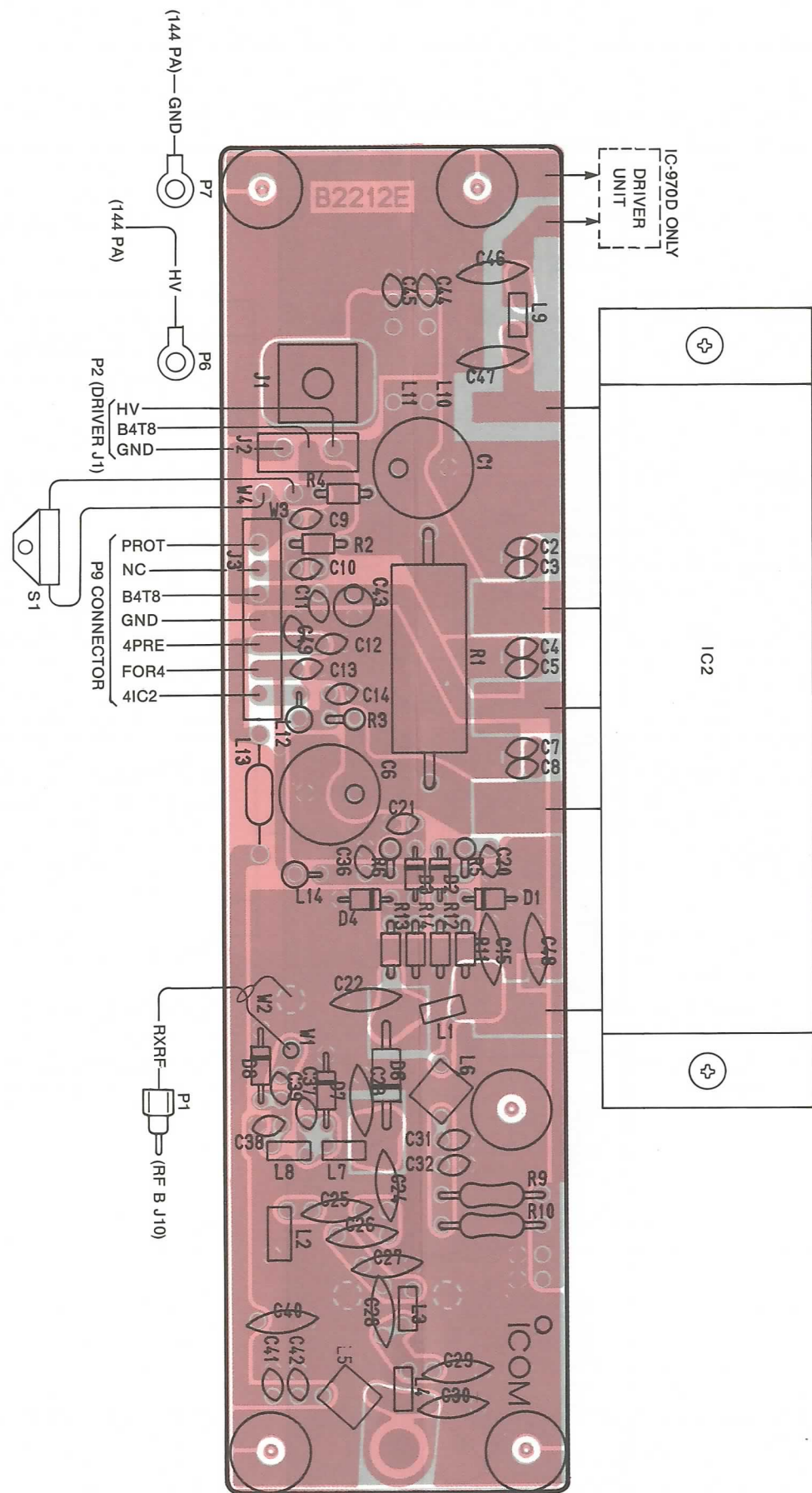

• 430 PA L UNIT (IC-970/M)

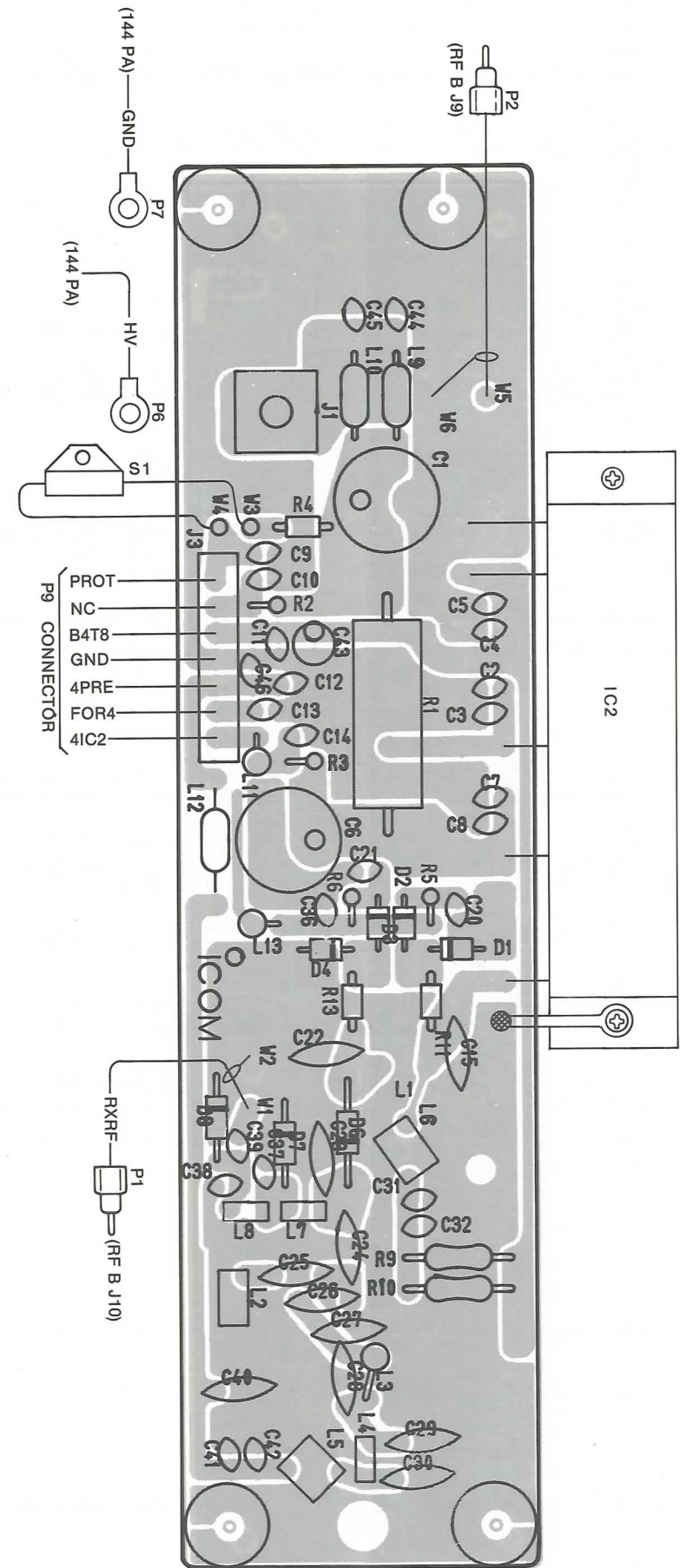

CONNECTOR CIRCUIT

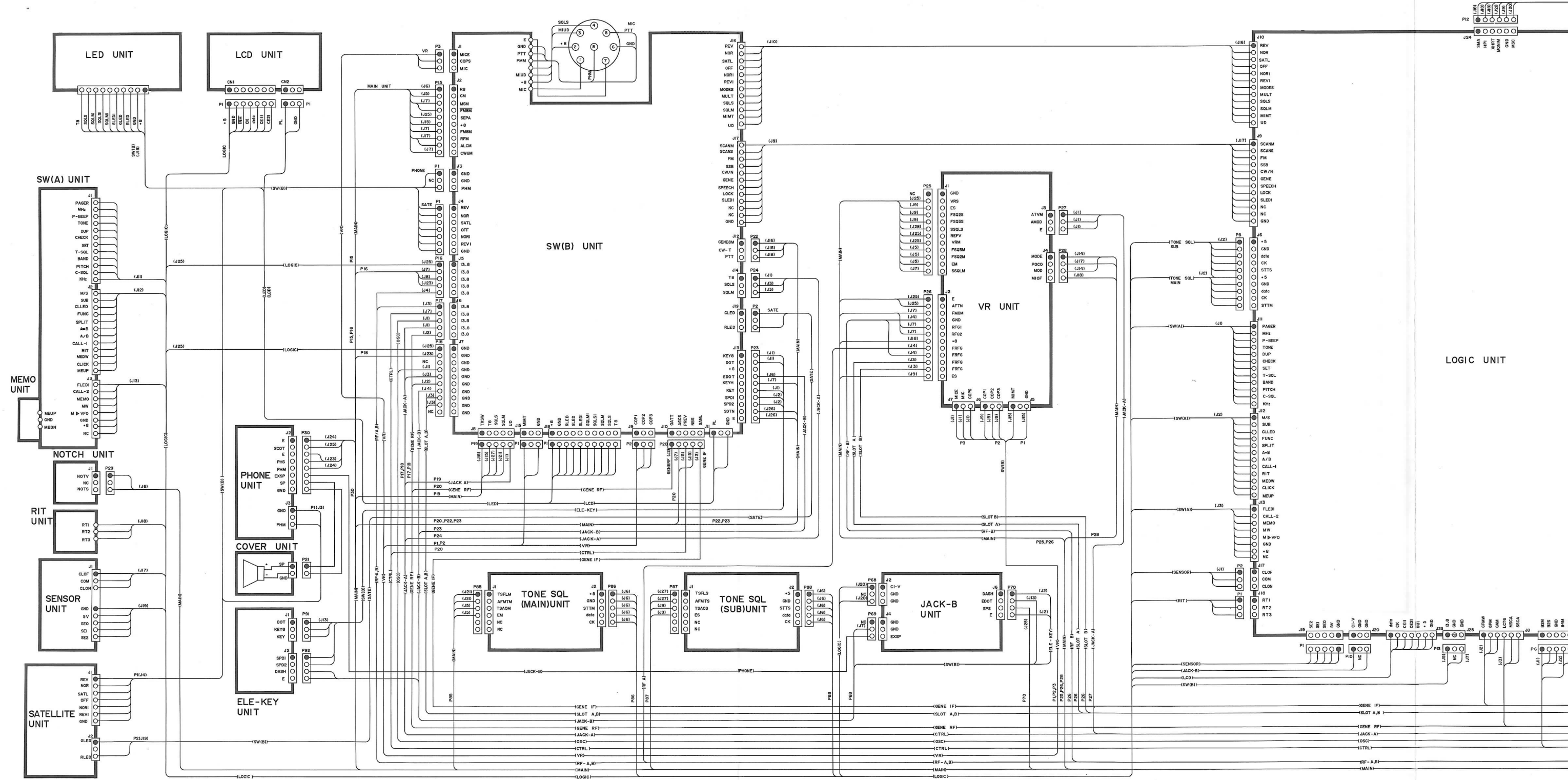

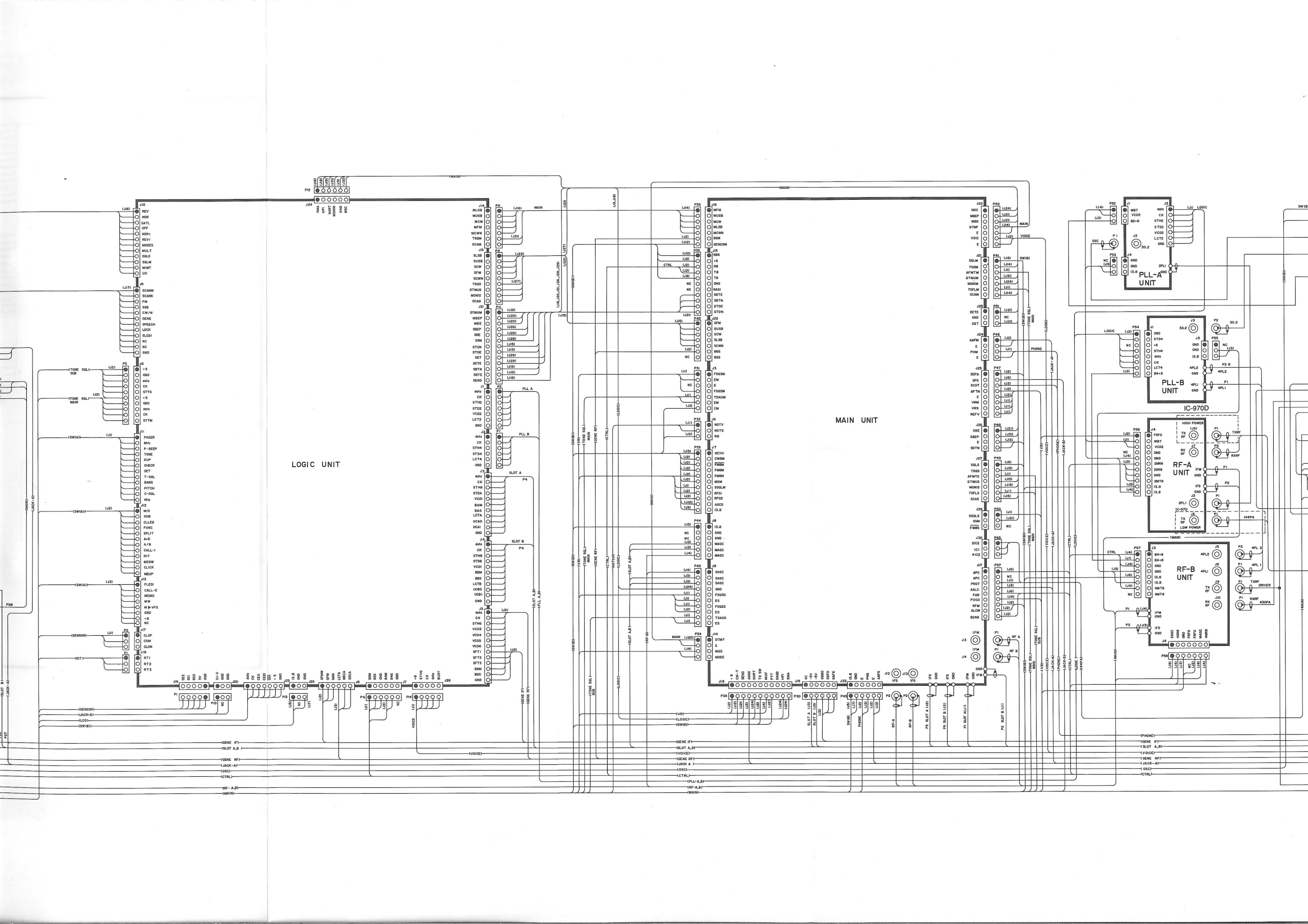

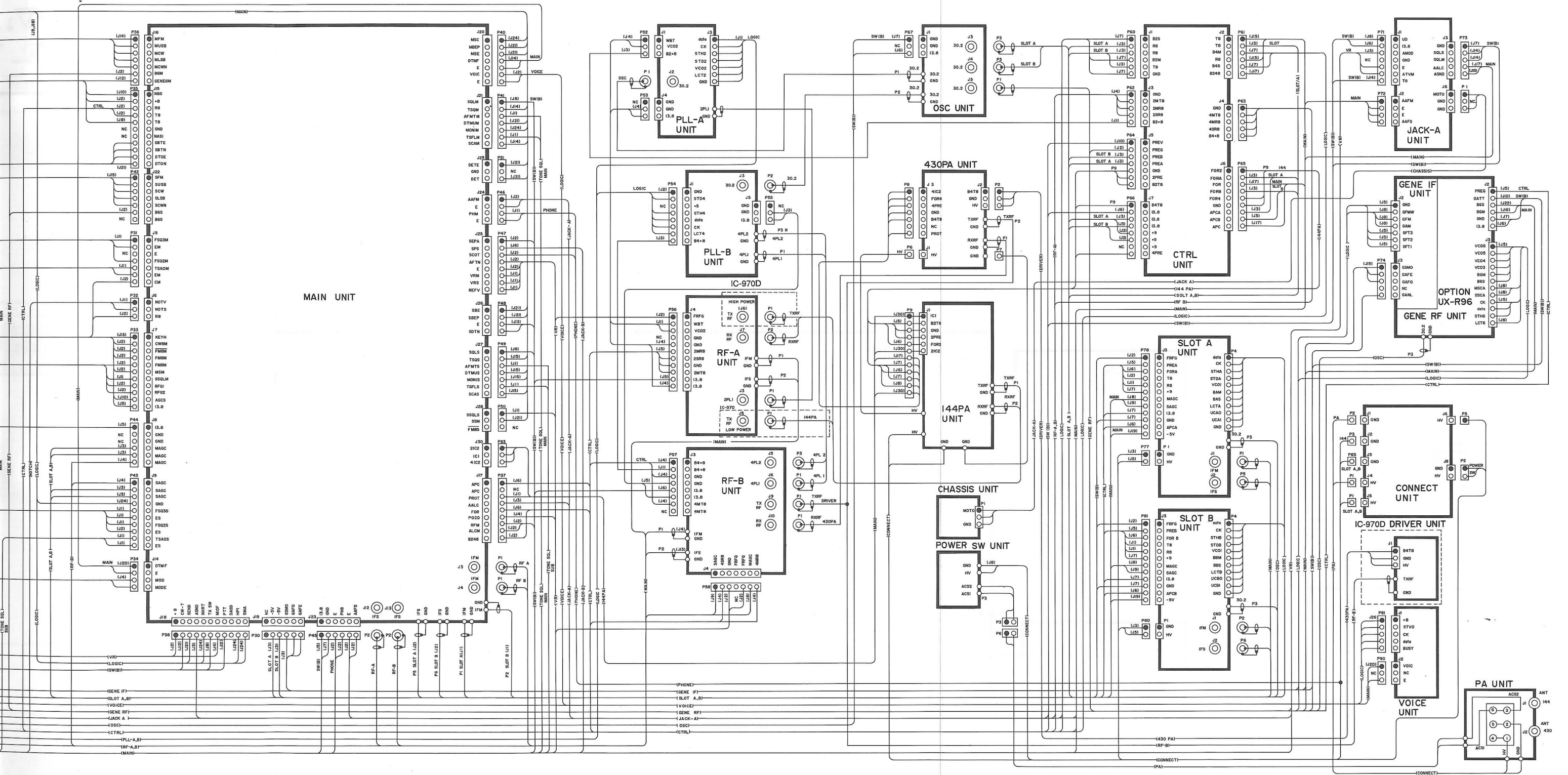

• VR, SW (B), SW (A), CTRL, etc. UNIT

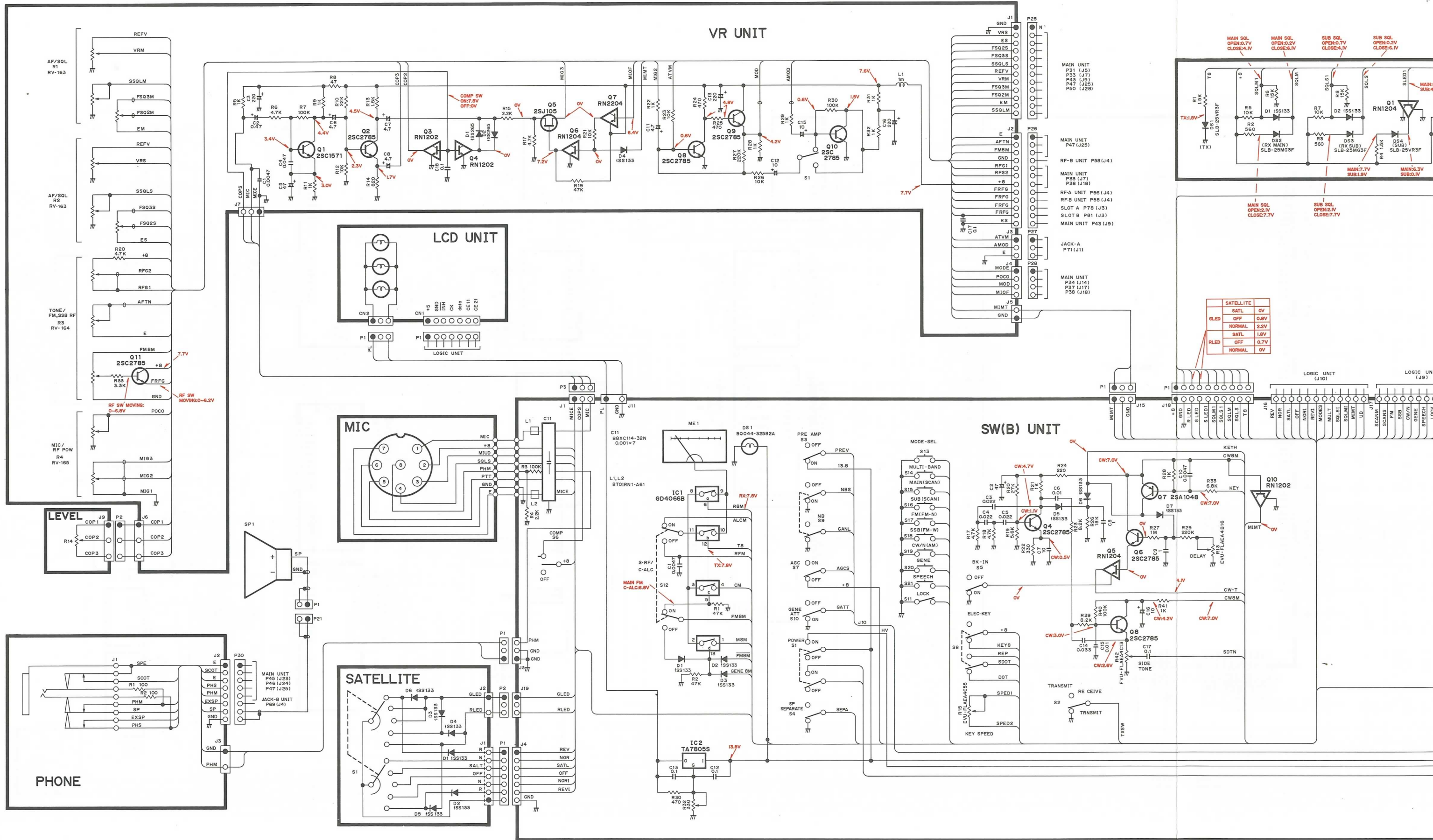

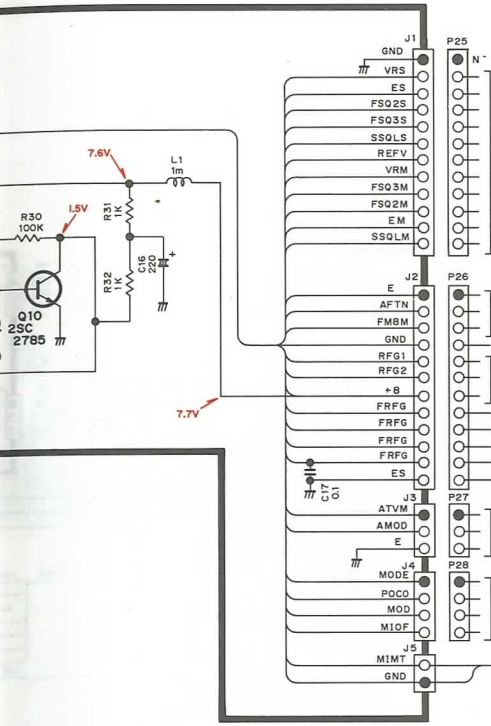

- MAIN UNIT P31 (J5)
- MAIN UNIT P33 (J7)
- MAIN UNIT P43 (J9)
- MAIN UNIT P47 (J25)
- RF-B UNIT P58 (J4)
- MAIN UNIT P33 (J7)
- MAIN UNIT P38 (J18)
- RF-A UNIT P56 (J4)
- RF-B UNIT P58 (J4)
- SLOT A P78 (J3)
- SLOT B P81 (J3)
- MAIN UNIT P43 (J9)
- JACK-A P71 (J1)
- MAIN UNIT P34 (J14)
- MAIN UNIT P37 (J17)
- MAIN UNIT P38 (J18)

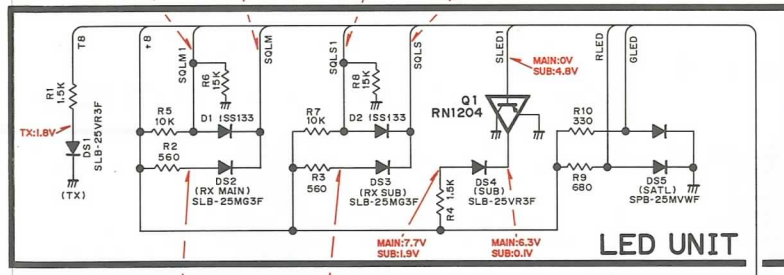

LED	STATE	VOLTAGE
SATELLITE	SATL	0V
GLED	OFF	0.8V
	NORMAL	2.2V
	SATL	1.8V
RLED	OFF	0.7V
	NORMAL	0V

SW(B) UNIT

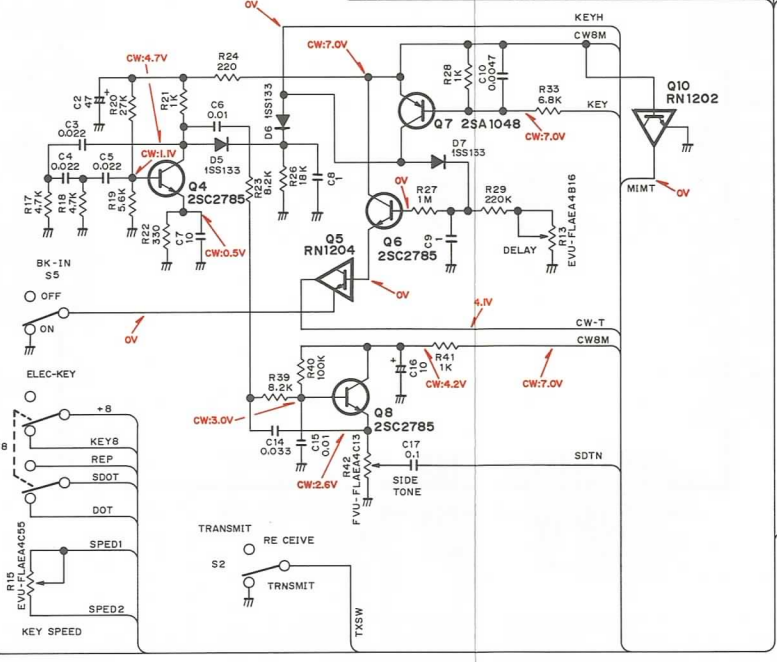

- GENE RF (J2)
- MAIN UNIT P33 (J7)
- CTRL P64 (J5)
- MAIN UNIT P38 (J18)
- GENE IF P74 (J3)
- MAIN UNIT P31 (J5)
- MAIN UNIT P32 (J6)
- MAIN UNIT P33 (J7)
- MAIN UNIT P35 (J15)
- MAIN UNIT P37 (J17)
- MAIN UNIT P47 (J25)
- LOGIC UNIT P13 (J25)
- MAIN UNIT P33 (J7)
- MAIN UNIT P44 (J8)
- MAIN UNIT P45 (J23)
- RF-A UNIT P56 (J4)
- RF-B UNIT P57 (J3)
- CTRL P66 (J7)
- OSC P67 (J1)
- JACK-A P71 (J1)
- GENE RF (J2)
- LOGIC UNIT P13 (J25)
- MAIN UNIT P45 (J23)
- OSC P67 (J1)
- JACK-A P73 (J3)
- GENE RF (J2)
- JACK-B P69 (J4)
- SLOT A P78 (J3)
- SLOT B P81 (J3)
- MAIN UNIT P35 (J15)
- MAIN UNIT P38 (J18)
- MAIN UNIT P41 (J21)
- MAIN UNIT P49 (J27)
- JACK-A P71 (J1)
- JACK-A P71 (J1)
- P75 (J3)
- ELE-KEY P91 (J1)
- JACK-B P70 (J6)
- MAIN UNIT P33 (J7)
- ELE-KEY P91 (J1)
- SPD1 P92 (J2)
- MAIN UNIT P48 (J26)
- MAIN UNIT P36 (J16)
- MAIN UNIT P38 (J18)

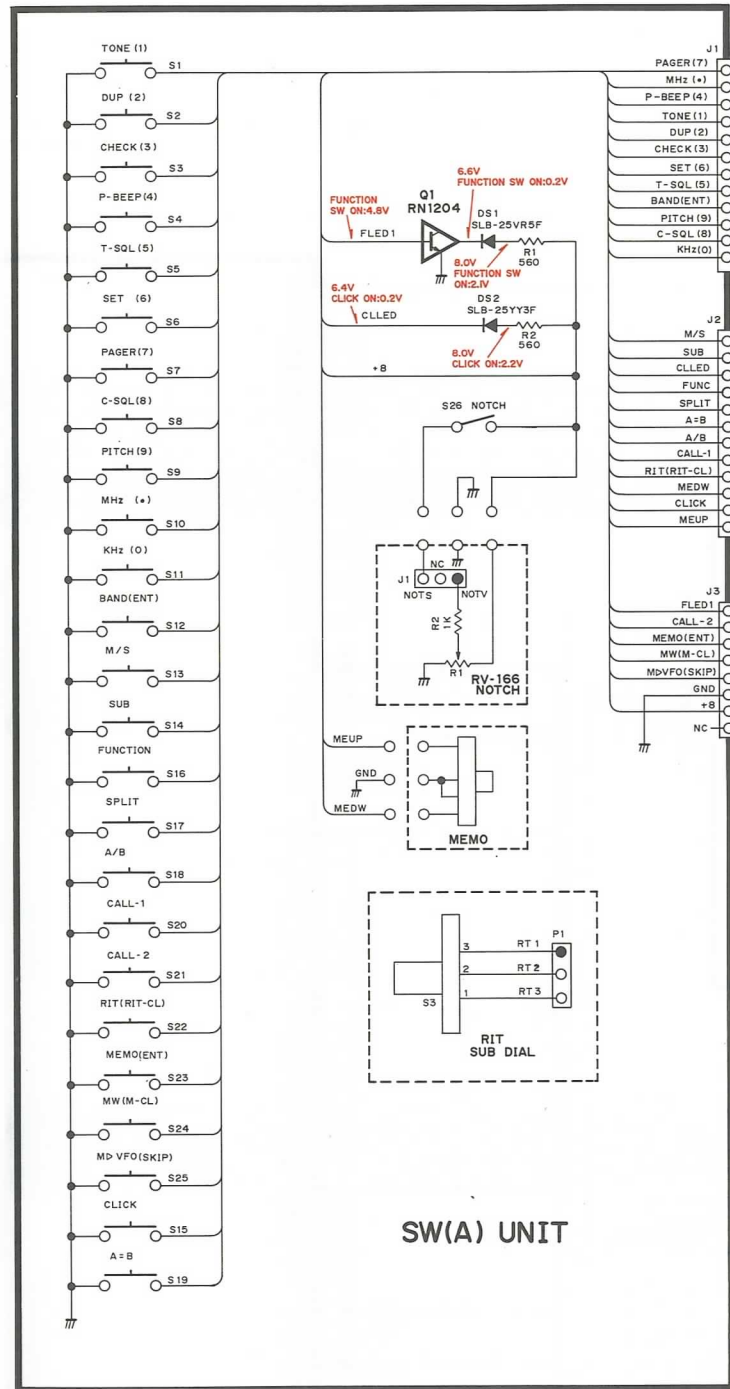

SW(A) UNIT

- LOGIC UNIT (J11)
- LOGIC UNIT (J12)
- LOGIC UNIT (J13)

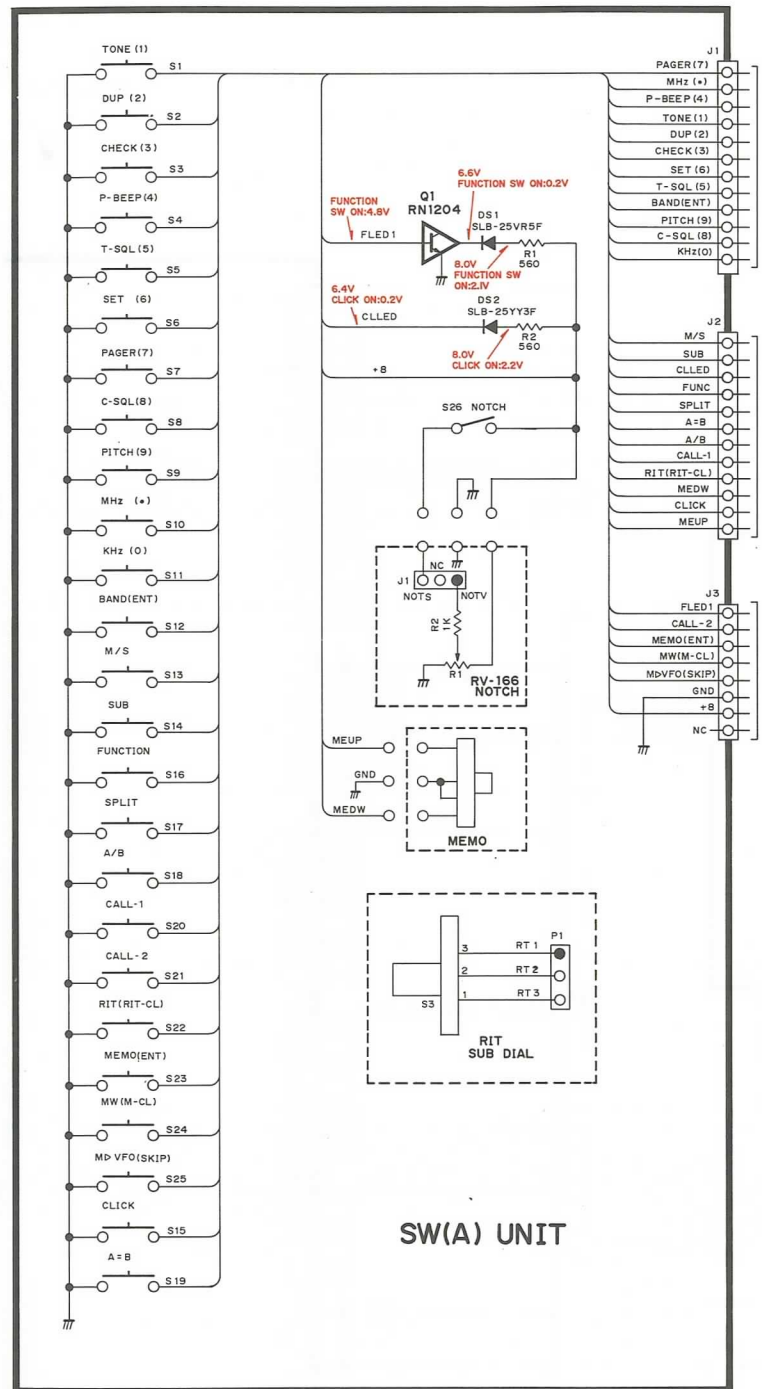

SW(A) UNIT

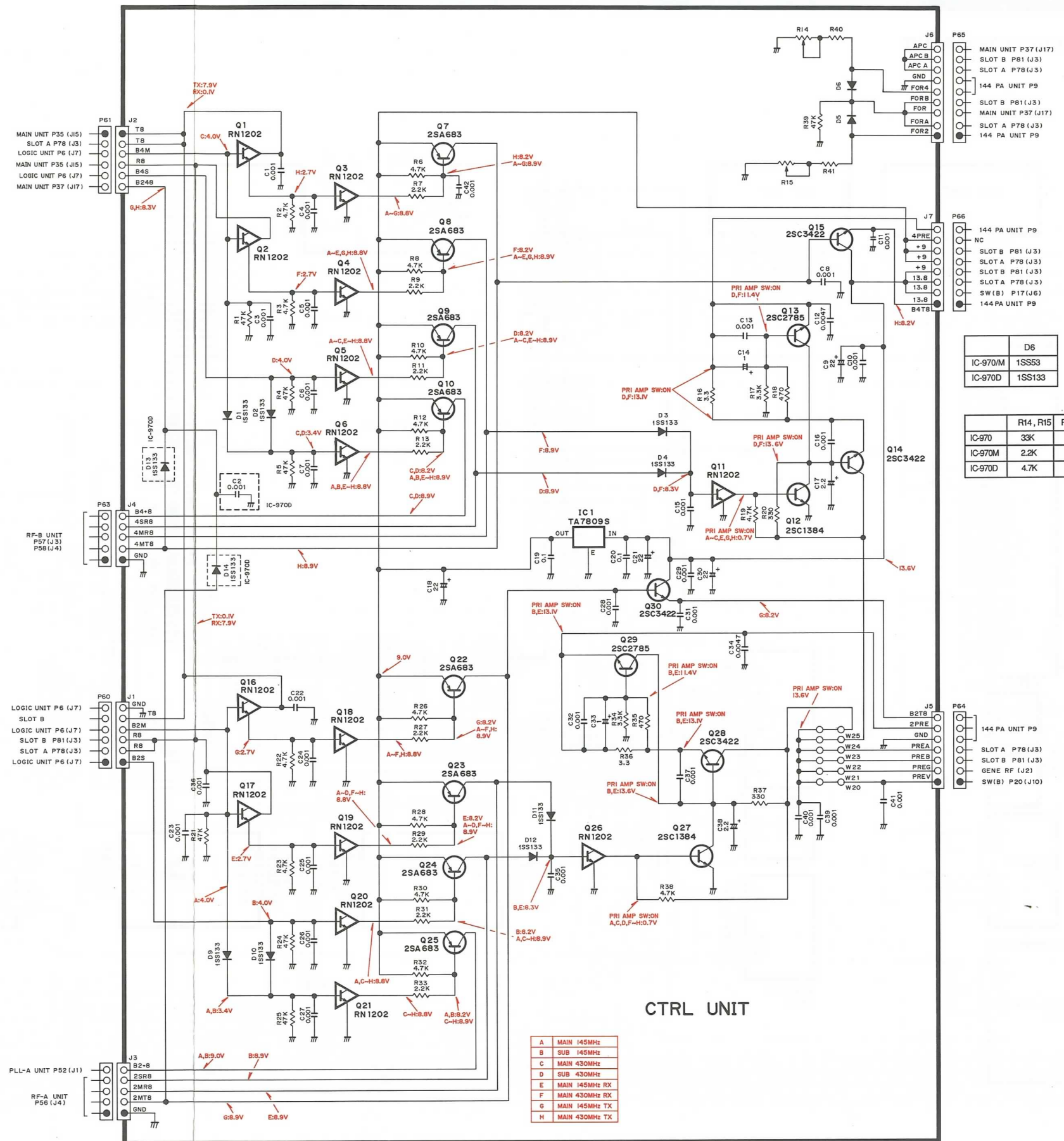

CTRL UNIT

A	MAIN	145MHz
B	SUB	145MHz
C	MAIN	430MHz
D	SUB	430MHz
E	MAIN	145MHz RX
F	MAIN	430MHz RX
G	MAIN	145MHz TX
H	MAIN	430MHz TX

P65	MAIN UNIT P37 (J17)
	SLOT B P81 (J3)
	SLOT A P78 (J3)
	144 PA UNIT P9
	SLOT B P81 (J3)
	SLOT A P78 (J3)
	144 PA UNIT P9

P66	144 PA UNIT P9
	NC
	SLOT A P78 (J3)
	SLOT B P81 (J3)
	SLOT A P78 (J3)
	SW (B) P17 (J6)
	144 PA UNIT P9

	D6
IC-970M	1SS53
IC-970D	1SS133

	R14, R15	R40, R41
IC-970	33K	1K
IC-970M	2.2K	470
IC-970D	4.7K	1K

• LOGIC UNIT

LOGIC UNIT

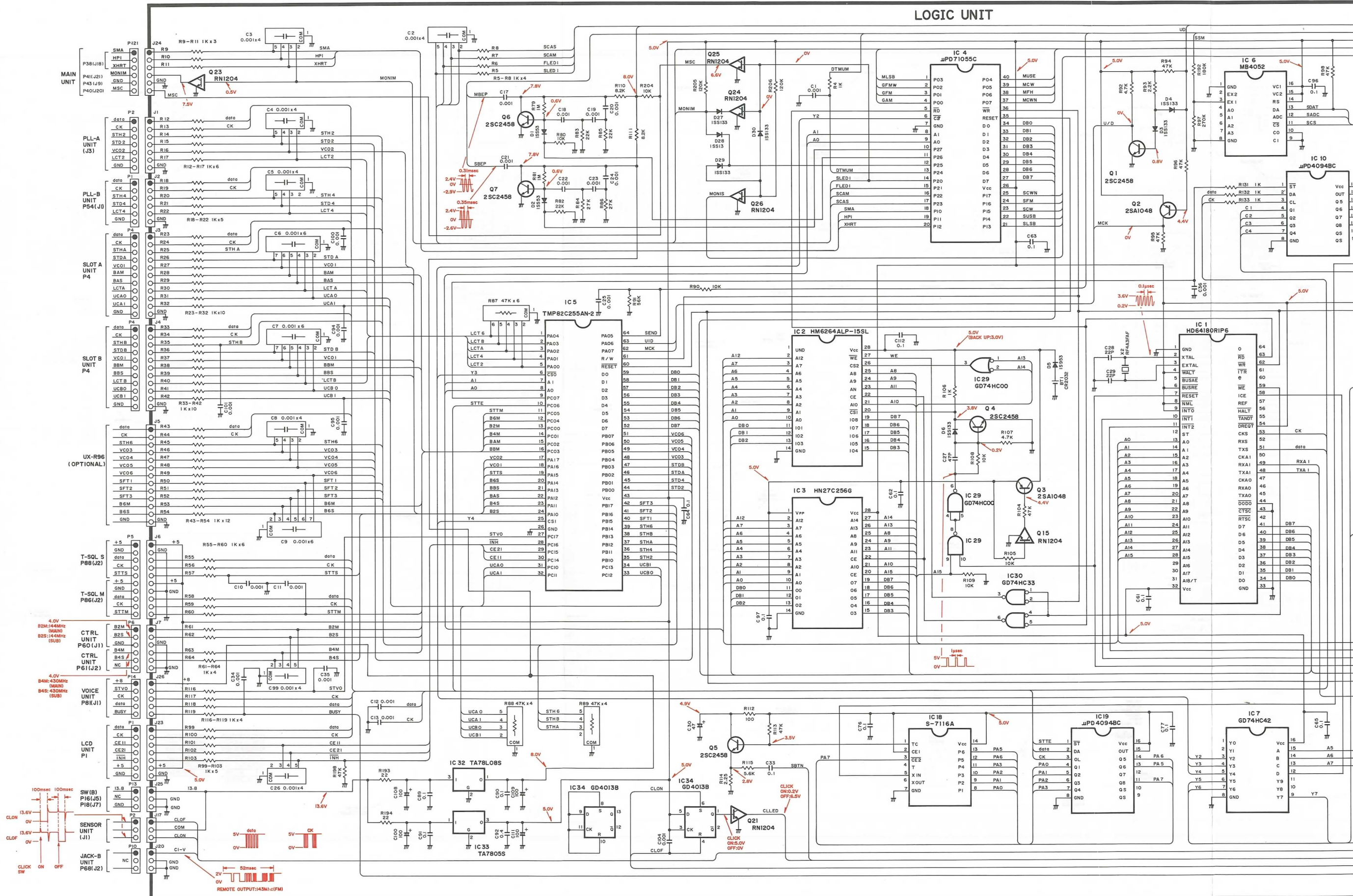

LOGIC UNIT

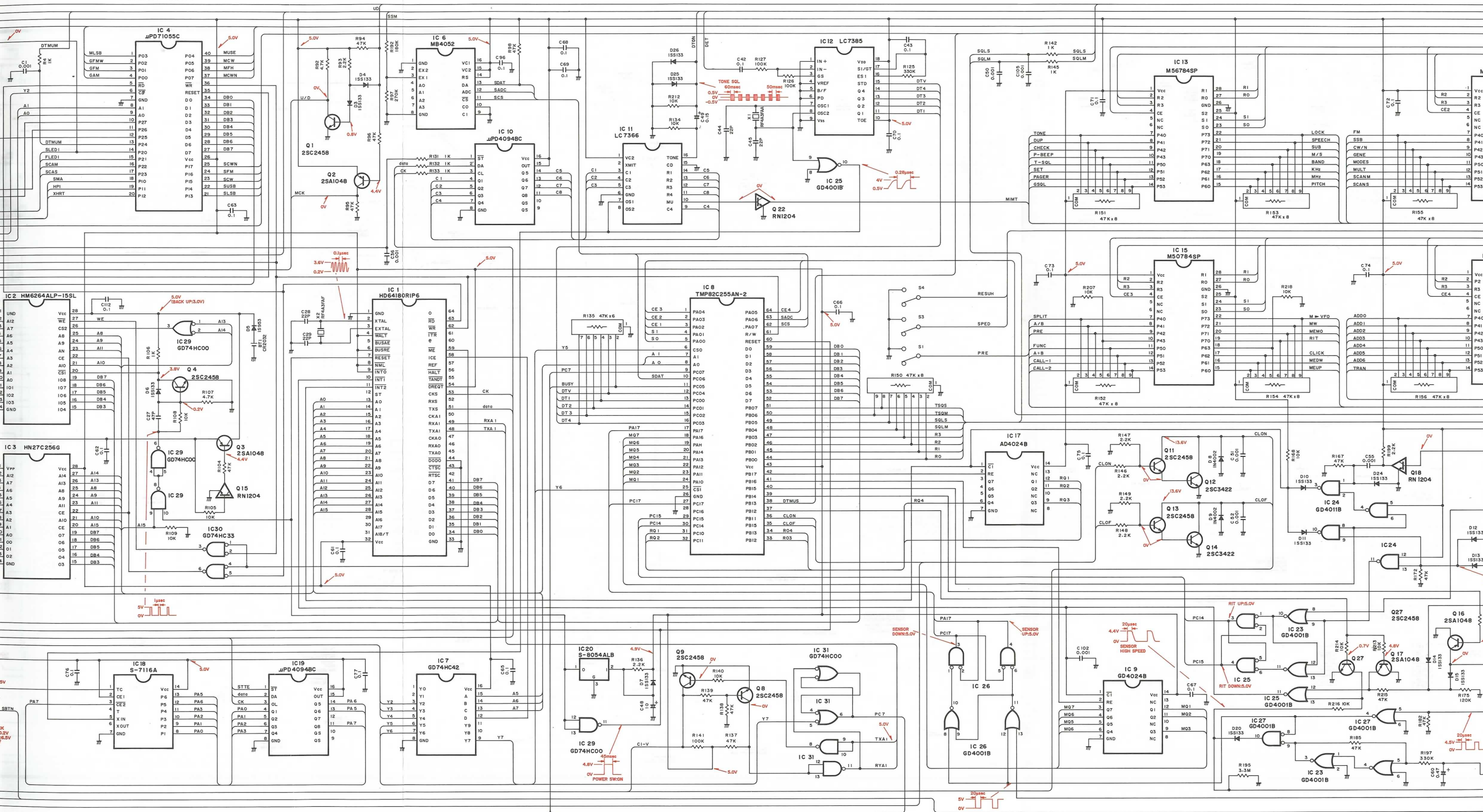

• LOGIC UNIT

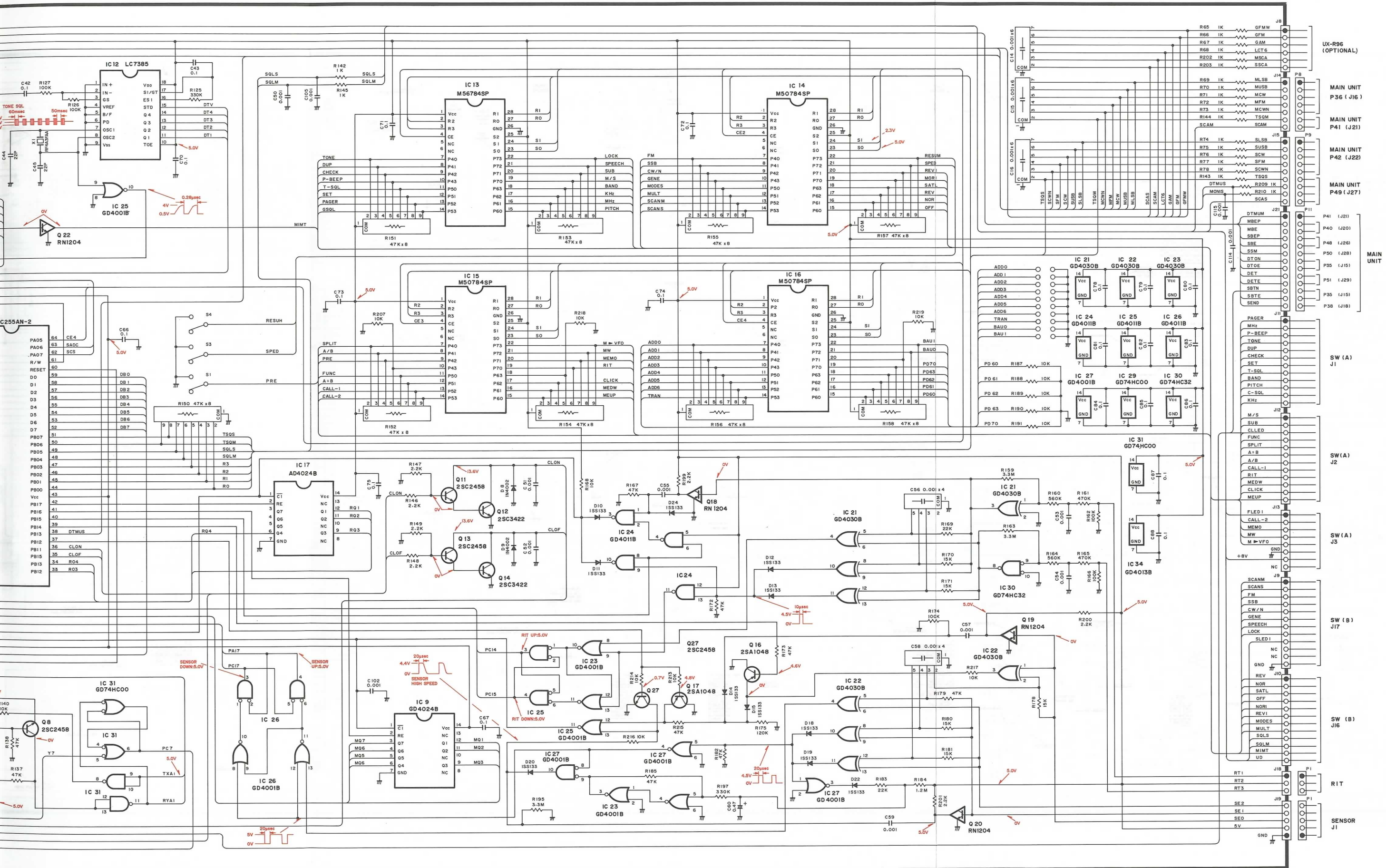

- UX-R96 (OPTIONAL)
- MAIN UNIT P36 (J16)
- MAIN UNIT P41 (J21)
- MAIN UNIT P42 (J22)
- MAIN UNIT P49 (J27)
- P41 (J21)
- P40 (J20)
- P48 (J26)
- P50 (J28)
- P51 (J29)
- P30 (J10)
- P38 (J18)
- SW (A) J1
- SW (A) J2
- SW (A) J3
- SW (B) J17
- SW (B) J16
- RIT
- SENSOR J1

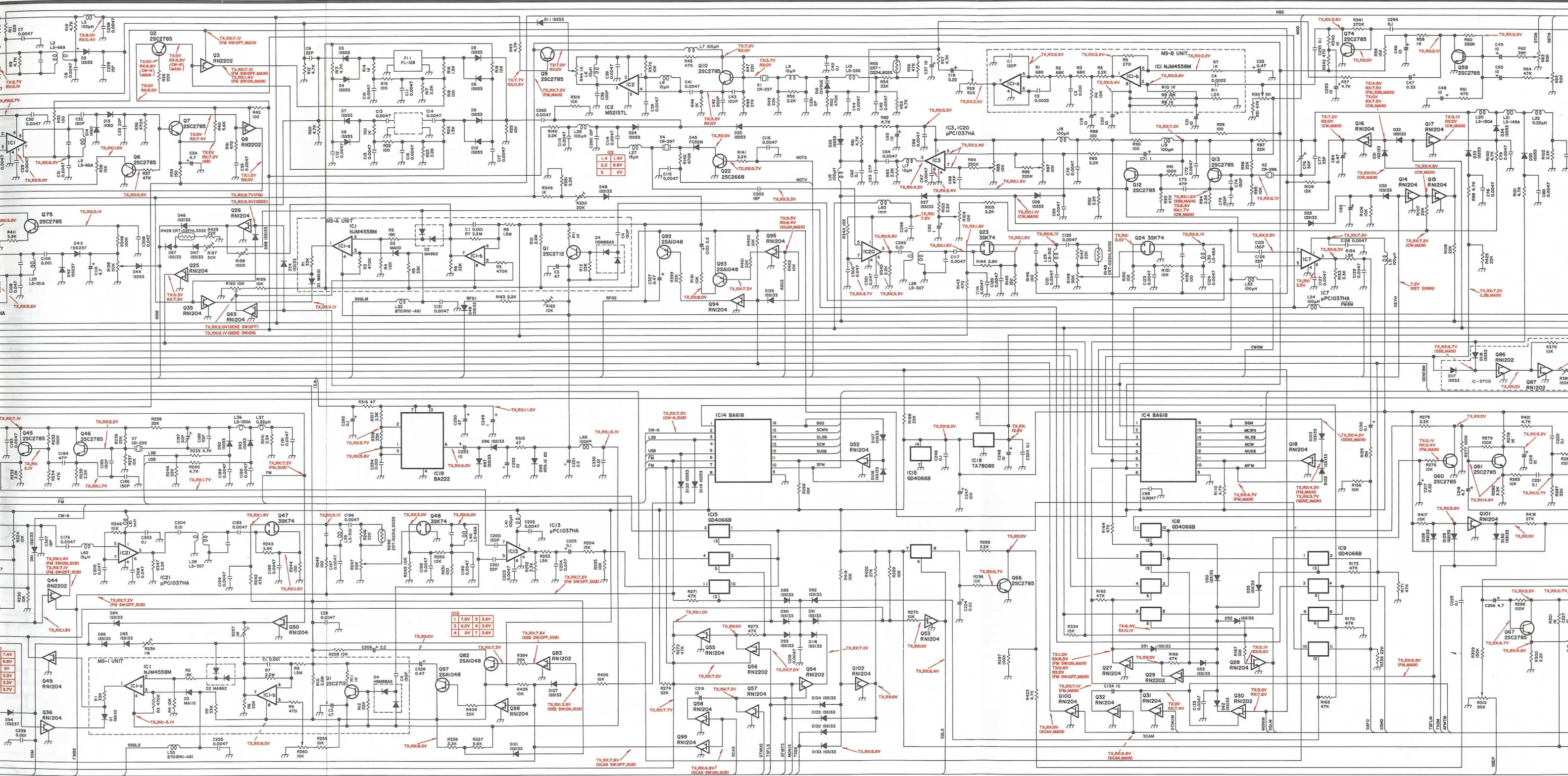

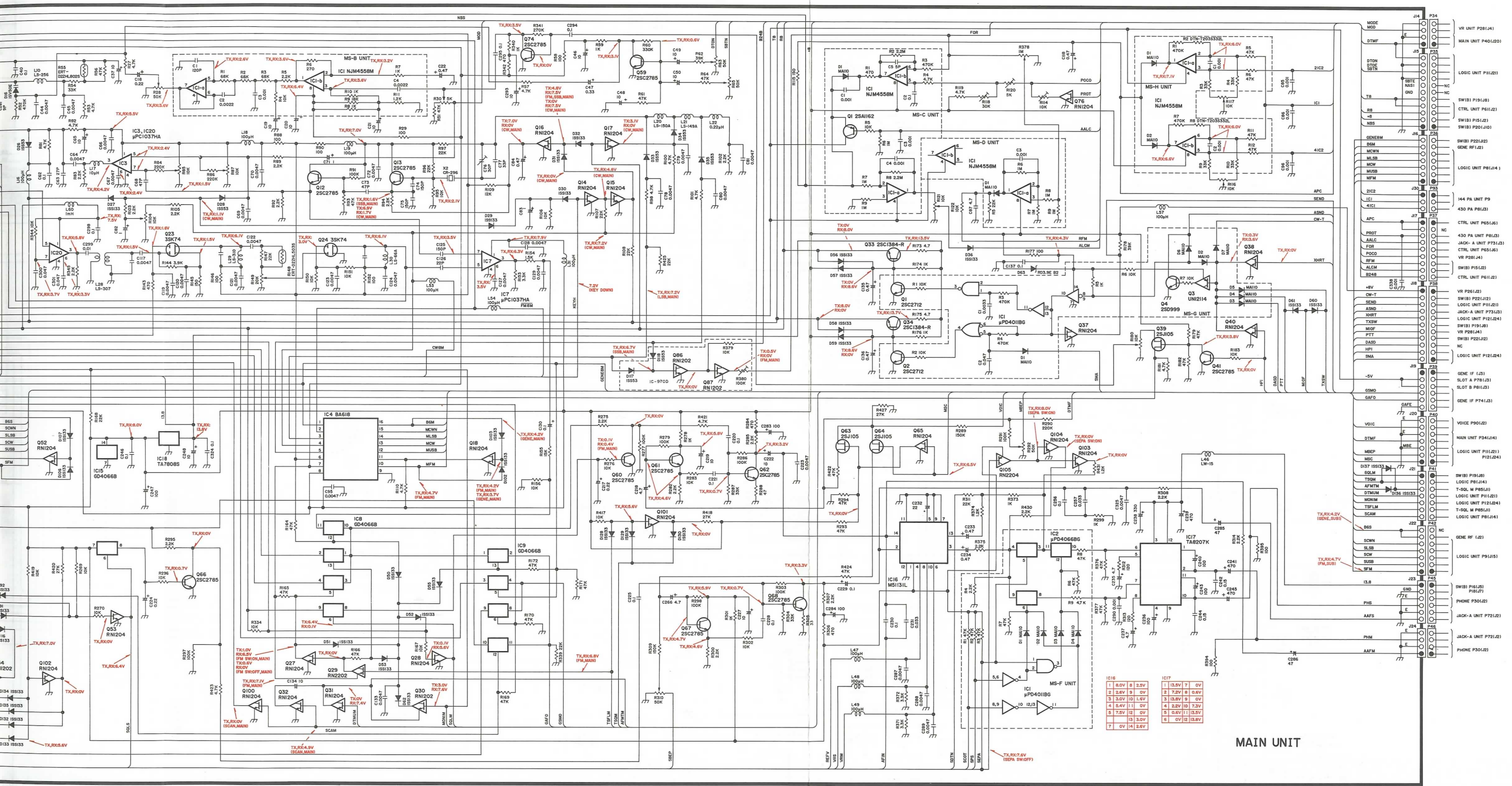

IC6	1	8.0V	8	3.2V
	2	2.8V	9	0V
	3	3.0V	10	1.6V
	4	5.4V	11	0V
	5	7.5V	12	0V
	6	0V	13	3.0V
	7	0V	14	2.6V

MAIN UNIT

• PLL-A, PLL-B UNIT

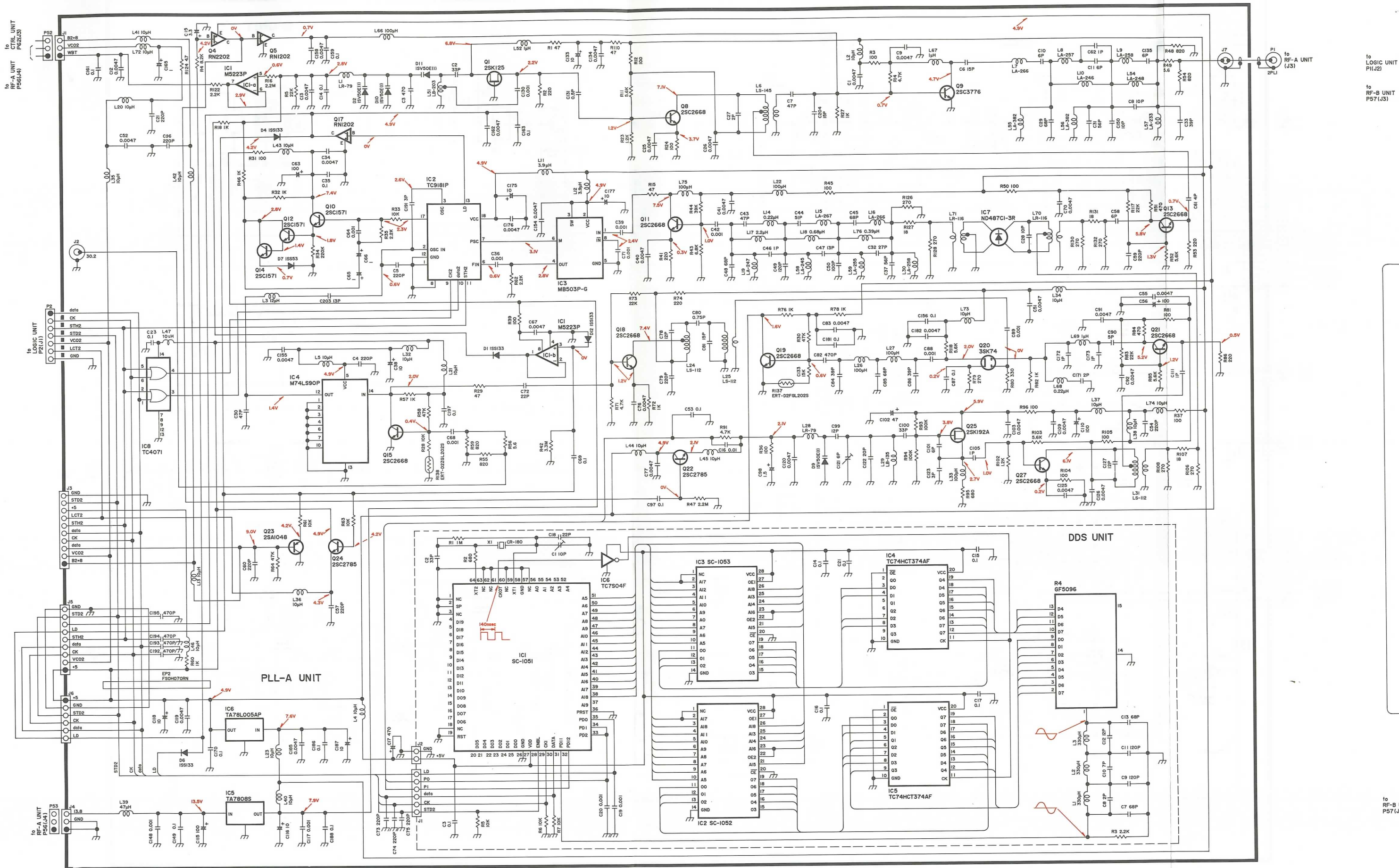

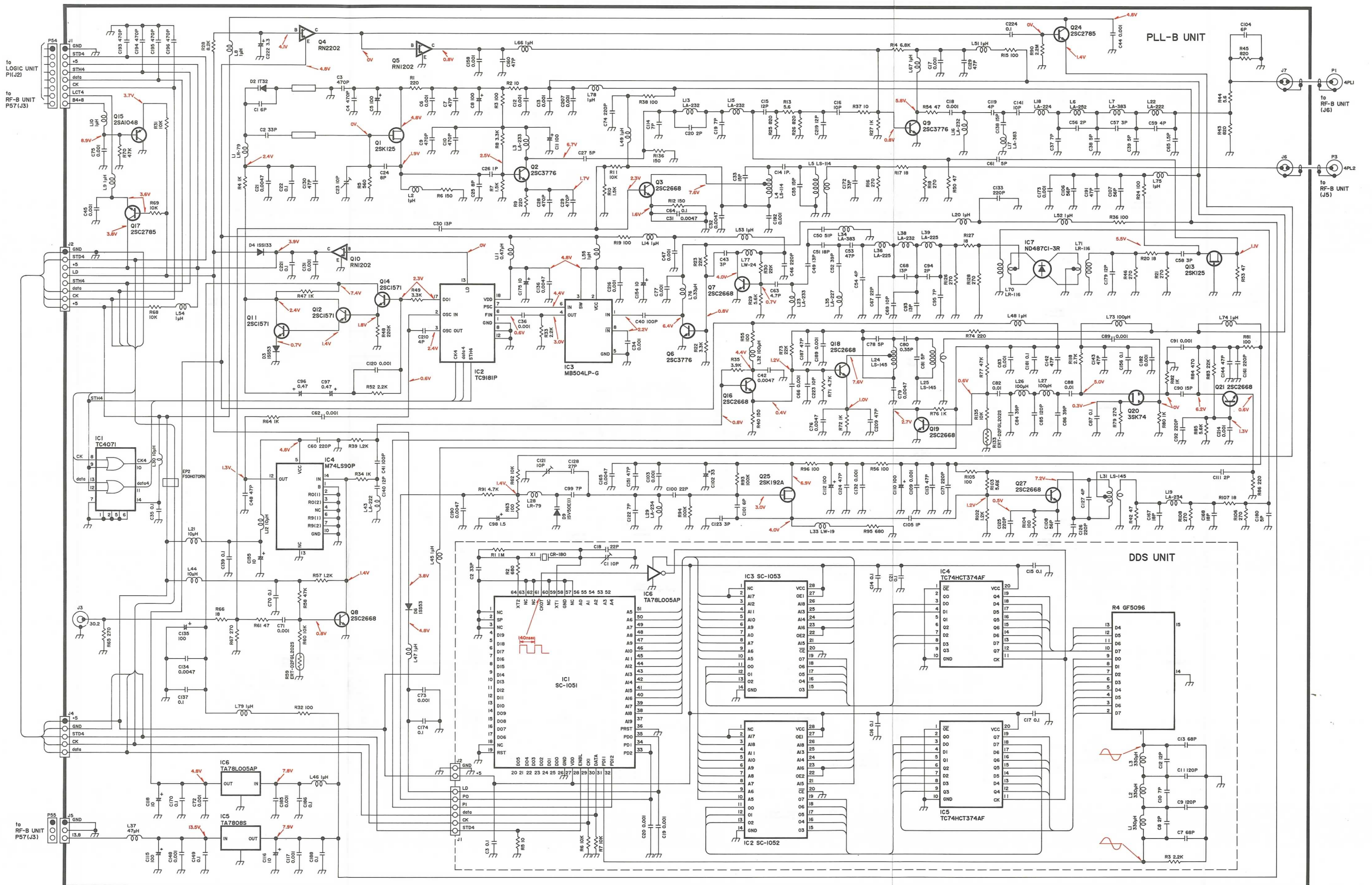

• RF-A, RF-B UNIT

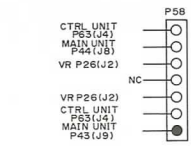
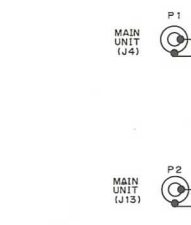
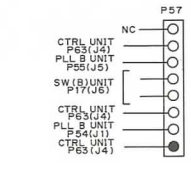
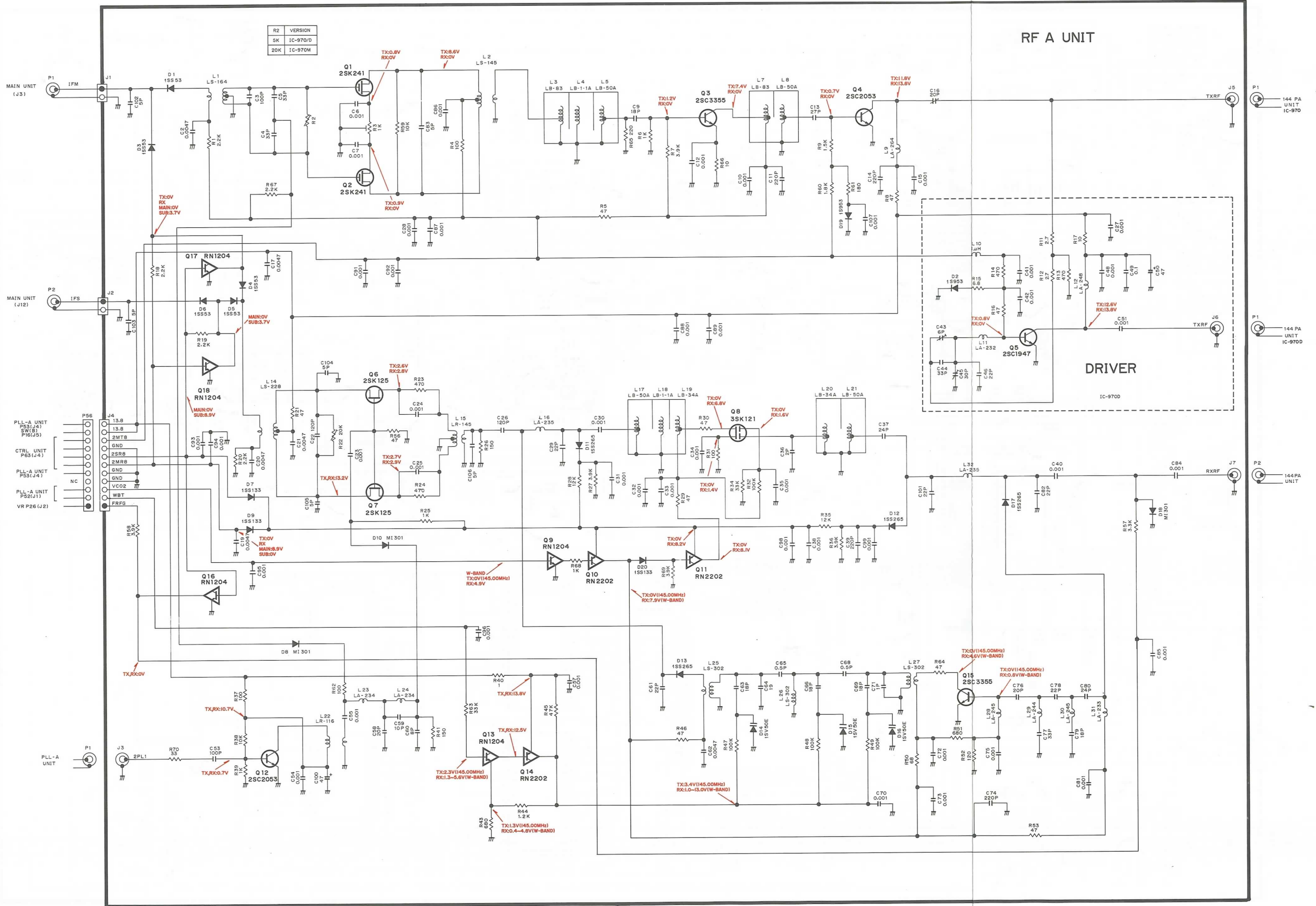

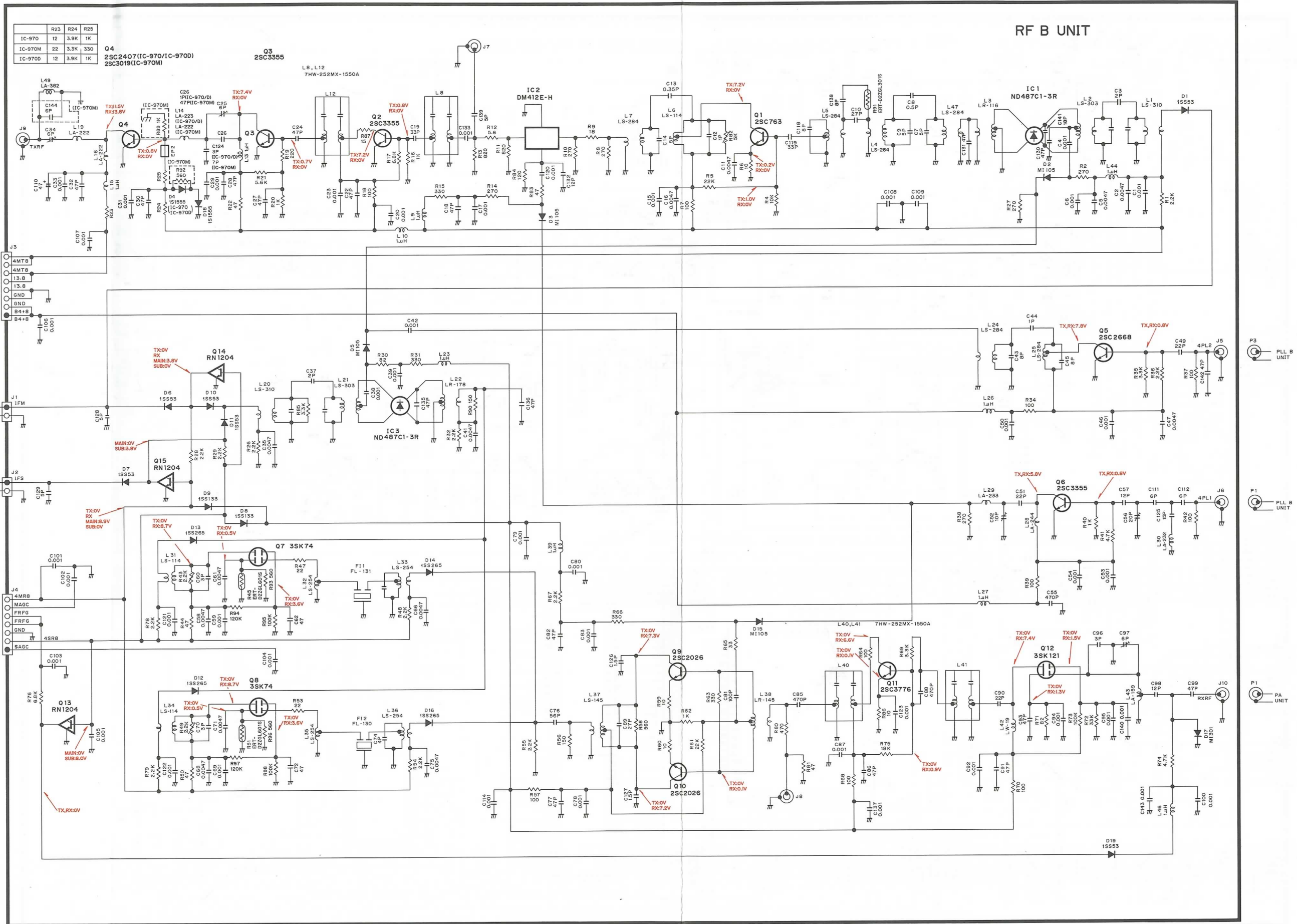

• OSC, 144 PA, 430 PA, JACK-A, JACK-B UNIT

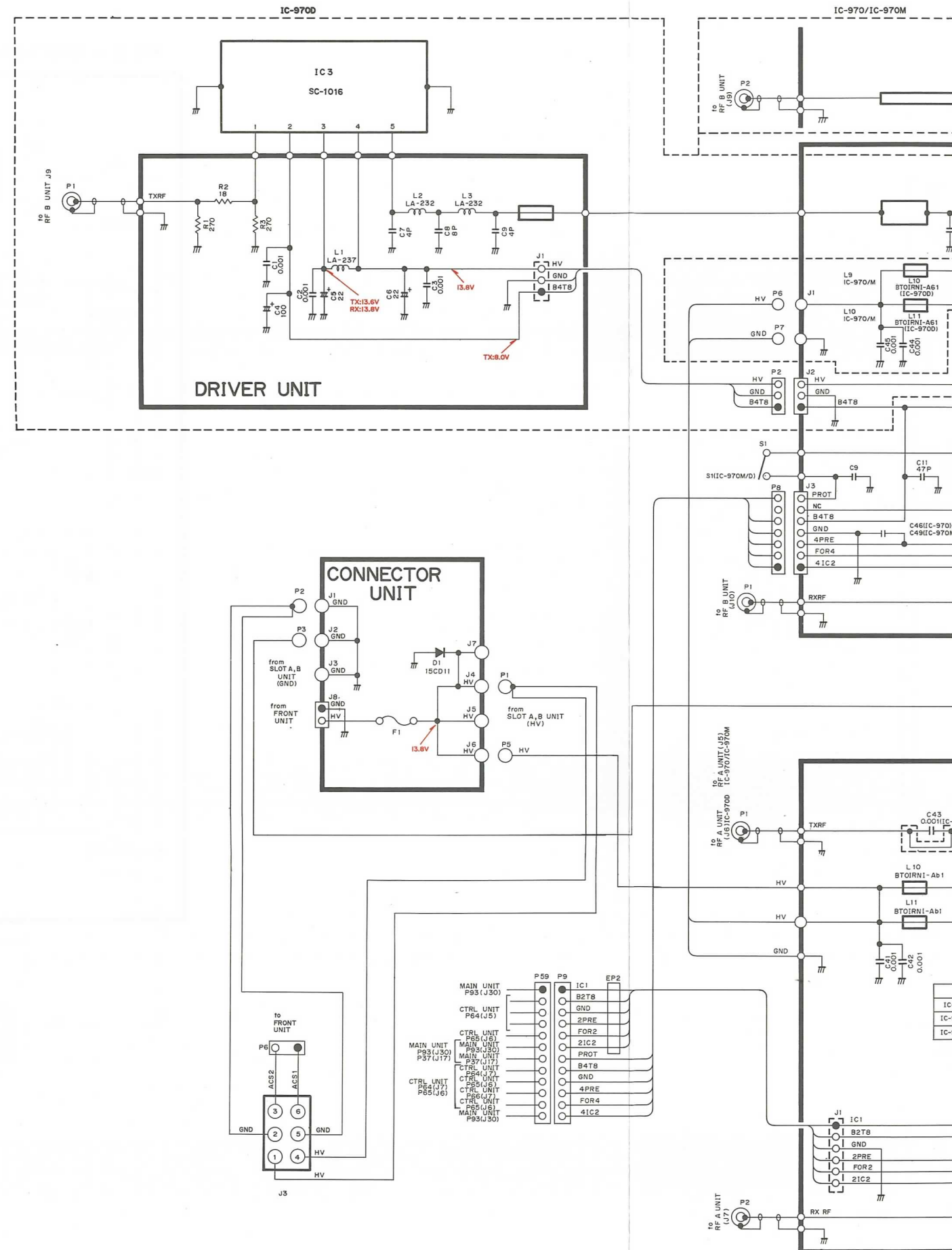
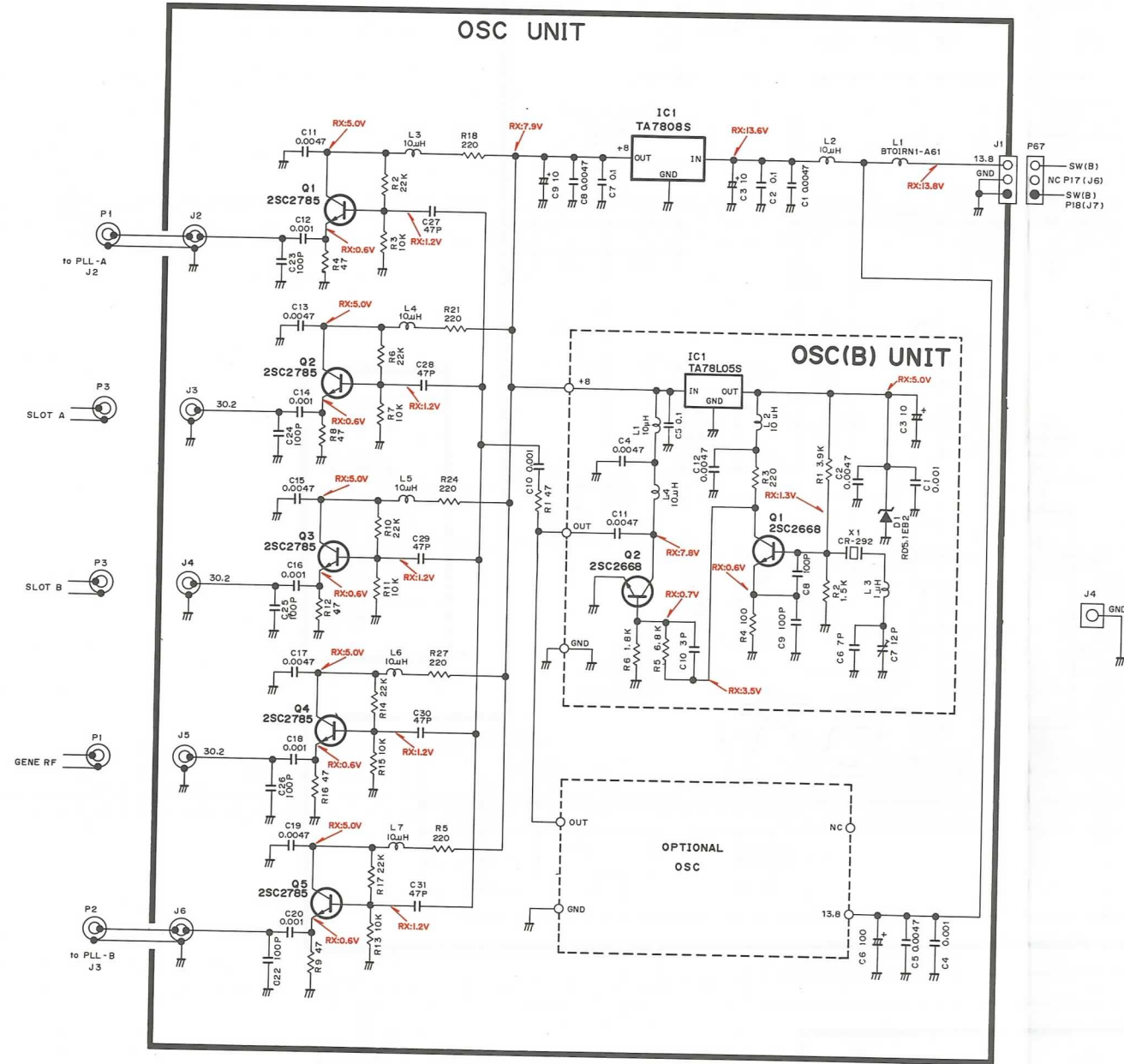

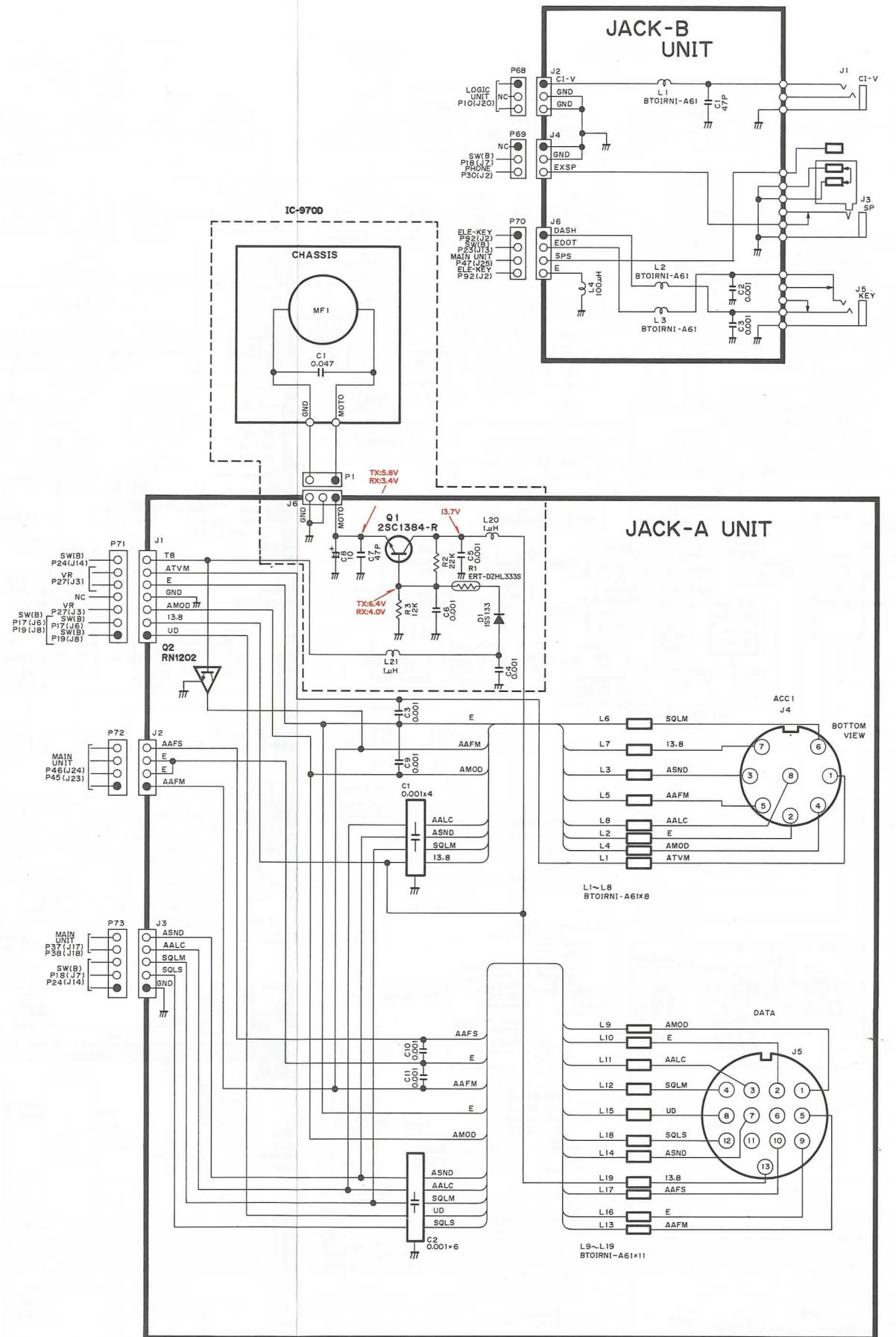
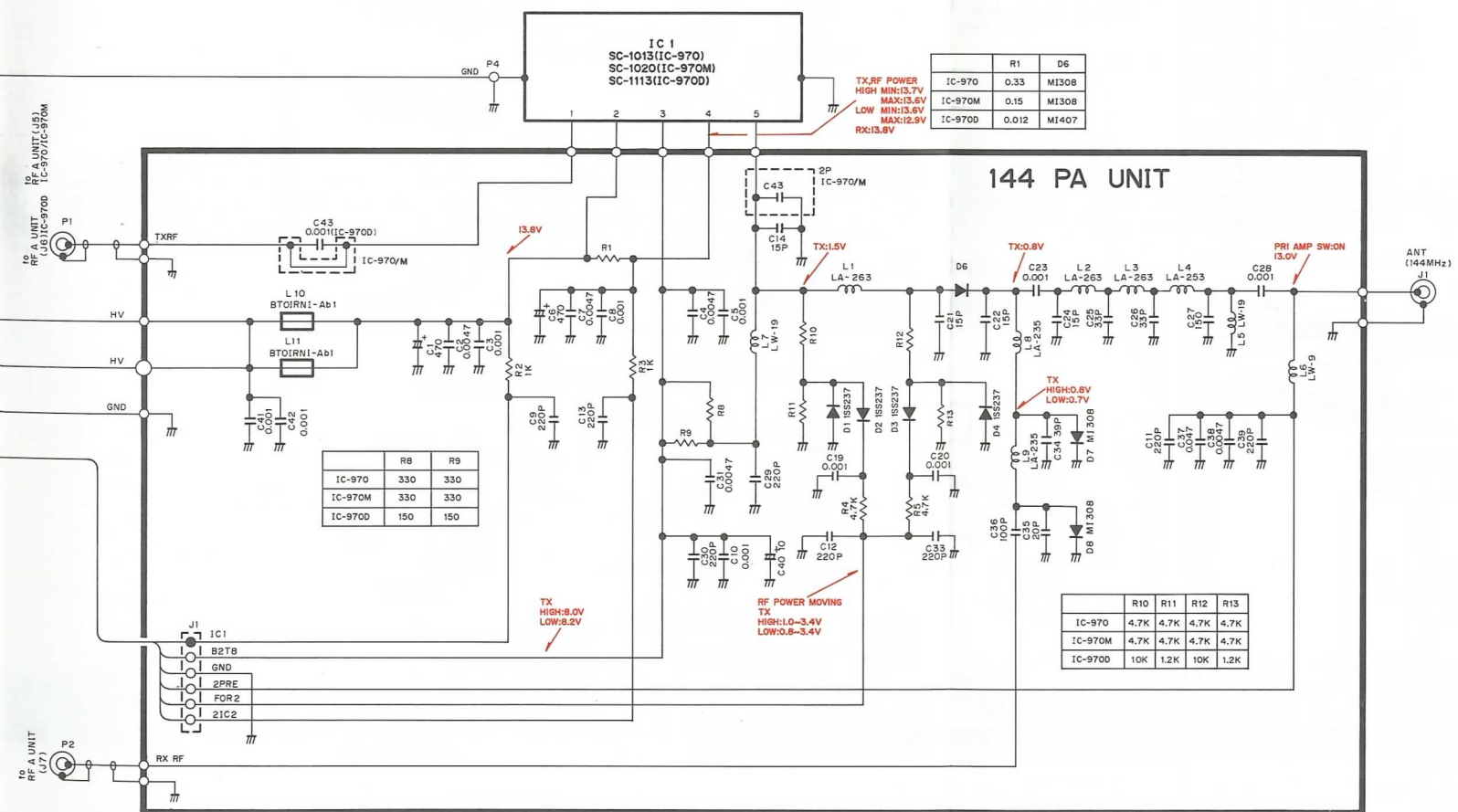
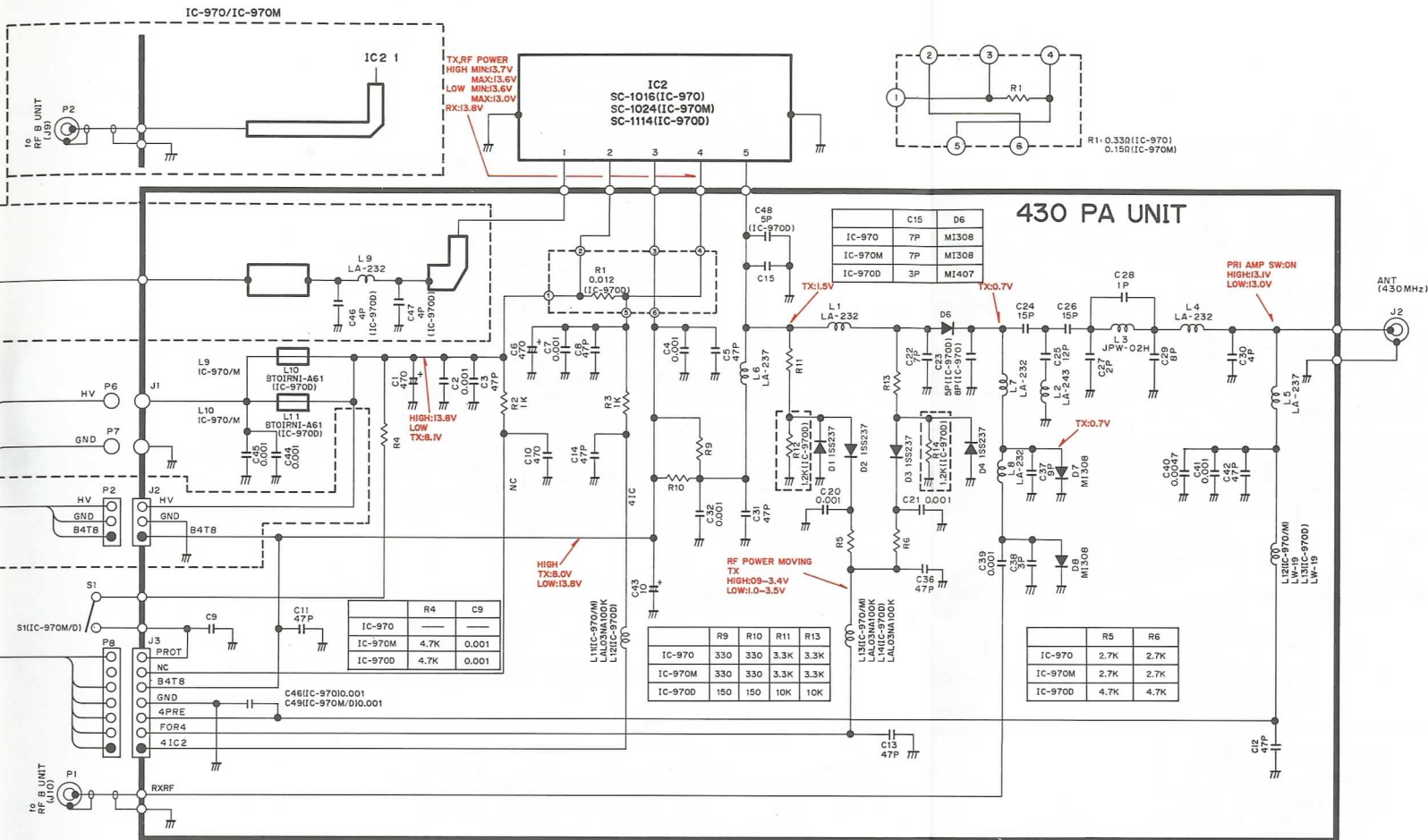

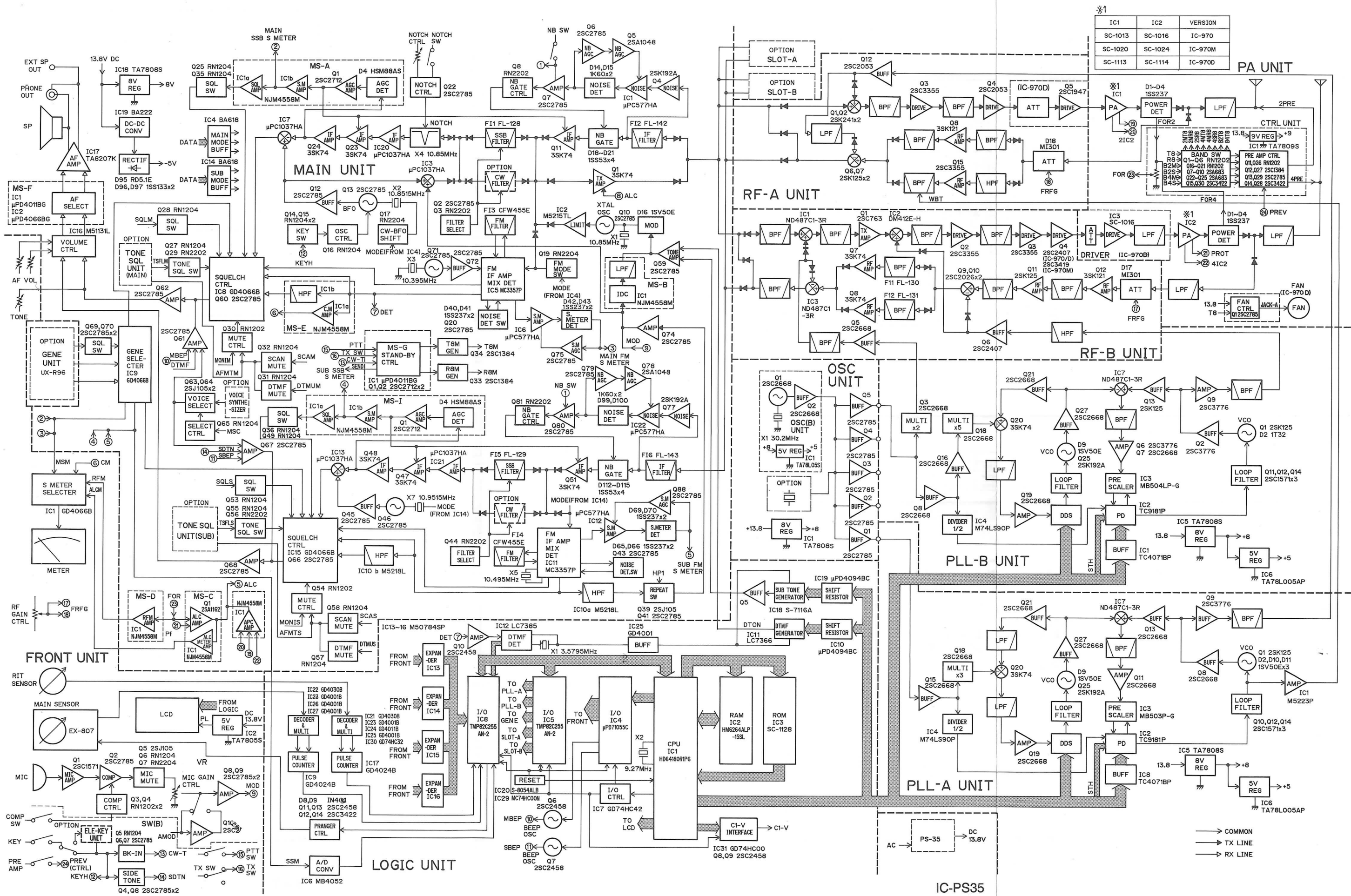

IC1	IC2	VERSION
SC-1013	SC-1016	IC-970
SC-1020	SC-1024	IC-970M
SC-1113	SC-1114	IC-970D

PA UNIT

RF-A UNIT

RF-B UNIT

OSC UNIT

PLL-B UNIT

PLL-A UNIT

IC-PS35

→ COMMON
 → TX LINE
 → RX LINE

• IC-PS35 (内蔵電源)

• ブロック図、IC-PS35 (内蔵電源)

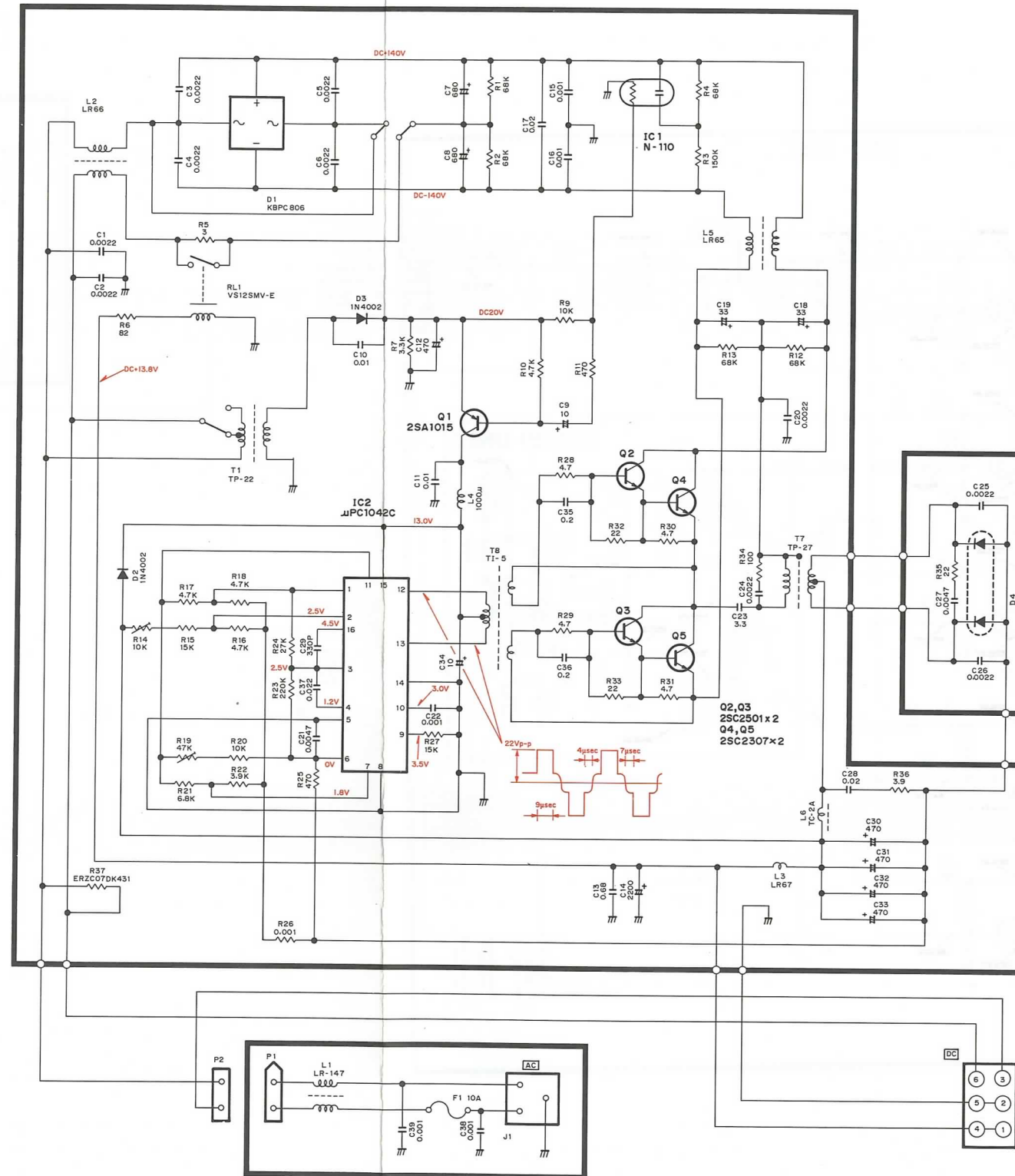

高品質がテーマです。

アイコム株式会社

本社	547 大阪市平野区加美東6丁目9-16	TEL (011)251-3888
北海道営業所	060 札幌市中央区大通東9丁目14	TEL (022)285-7785
仙台営業所	982 仙台市若林区若林1丁目13-48	TEL (03)3621-8649
東京営業所	130 東京都墨田区亀沢1丁目4-18	TEL (052)842-2288
名古屋営業所	466 名古屋市昭和区長戸町2丁目16-3	TEL (0762) 91-8881
金沢出張所	921 金沢市高島1丁目335	TEL (06)793-0331
大阪営業所	547 大阪市平野区加美南1丁目8-35	TEL (082)295-0331
広島営業所	733 広島市西区観音本町2丁目10-25	TEL (0878) 35-3723
四国営業所	760 高松市塩上町2丁目1-5	TEL (092)541-0211
九州営業所	815 福岡市南区塩原4丁目5-48	