

1200MHz ALL MODE TRANSCEIVER

IC-1271A/E

SERVICE MANUAL



ICOM INCORPORATED

1-6-19, Kamikuratsukuri, Hirano-ku, Osaka 547, Japan
Phone: (06) 793-5301
Telex: 05277822 ICOMTR J
Fax: (06) 793-0013

ICOM AMERICA, INC.,
2380 116th Avenue N.E.,
Bellevue, WA 98004
Phone: (206) 454-8155
Telex: 230-152210 ICOM AMER BVUE
Fax: (206) 454-1509

3150 Premier Drive, Suite 126,
Irving, TX 75063
Phone: (214) 550-7525
Fax: (214) 550-7423

1777 Phoenix Parkway, Suite 201,
Atlanta, GA 30349
Phone: (404) 991-6186

ICOM CANADA, LTD.,
3071-#5 Road, Unit 9,
Richmond, B.C.,
V6X 2T4 Canada
Phone: (604) 273-7400
Fax: (604) 273-1900

ICOM (EUROPE) GmbH,
Himmelgelster Strasse 100,
4000 Düsseldorf 1,
West Germany
Phone: 0211-346047
Telex: 41-8588082 ICOM D
Fax: 0211-333639

ICOM AUSTRALIA, PTY., LTD.,
7 Duke Street, Windsor 3181,
Victoria, Australia
Phone: (03) 529-7582
Telex: 71-35521 ICOMAS
Fax: (03) 529-8485

FOREWORD

Thank you very much for selecting the IC-1271A/E.

The IC-1271A/E is a complete, full-featured 1240 to 1300MHz base station transceiver developed by ICOM utilizing the latest computer and UHF technologies.



ASSISTANCE

Three separate versions of the IC-1271A/E have been designed for use in the U.S.A., Europe, and Australia. This service manual covers every version. When using the manual each model can be referred to by the following assigned version numbers:

- #02 EUROPE version
- #03 U.S.A. version
- #04 AUSTRALIA version

If you require assistance or information regarding the operation and capabilities of the IC-1271A/E, please contact your nearest authorized ICOM Dealer or ICOM Service Center.

TABLE OF CONTENTS

SECTION	1 SPECIFICATION	1 - 1
	1-1 GENERAL	1 - 1
	1-2 TRANSMITTER	1 - 1
	1-3 RECEIVER	1 - 1
SECTION	2 INSIDE AND OUTSIDE VIEWS	2 - 1 ~ 4
	2-1 FRONT PANEL	2 - 1
	2-2 CONTROLS UNDER THE ACCESS COVER	2 - 2
	2-3 REAR PANEL	2 - 2
	2-4 INSIDE TOP VIEW	2 - 3
	2-5 INSIDE BOTTOM VIEW	2 - 4
	2-6 PLL UNIT (LOCATED UNDER THE LOGIC UNIT)	2 - 4
SECTION	3 BLOCK DIAGRAM	3 - 1 ~ 2
	3-1 BLOCK DIAGRAM	3 - 1
	3-2 PA UNIT (TRANSISTOR-TYPE)	3 - 2
SECTION	4 CIRCUIT DESCRIPTION	4 - 1 ~ 16
	4-1 RECEIVER CIRCUITS	4 - 1 ~ 3
	4-2 TRANSMITTER CIRCUITS	4 - 3 ~ 6
	4-3 PLL CIRCUITS	4 - 6 ~ 7
	4-4 LOGIC CIRCUITS	4 - 8 ~ 15
	4-5 VCC CIRCUITS	4 - 15
	4-6 DISPLAY CIRCUITS	4 - 15 ~ 16
SECTION	5 MECHANICAL PARTS AND DISASSEMBLY	5 - 1 ~ 7
	5-1 FRAME DISASSEMBLY	5 - 1
	5-2 FRONT PANEL DISASSEMBLY	5 - 2
	5-3 REAR PANEL PARTS DISASSEMBLY	5 - 3
	5-4 MAIN UNIT CONNECTOR ASSEMBLY	5 - 4
	5-5 LOGIC/PLL UNIT ASSEMBLIES	5 - 5
	5-6 FRONT SUB-CHASSIS CONNECTOR OR ASSEMBLY	5 - 6
	5-7 REAR PANEL CONNECTOR ASSEMBLY	5 - 7
SECTION	6 MAINTENANCE AND ADJUSTMENT	6 - 1 ~ 13
	6-1 PREPARATION BEFORE SERVICING	6 - 1
	6-2 PLL ADJUSTMENT	6 - 2, 3
	6-3 RECEIVER ADJUSTMENT	6 - 4 ~ 7
	6-4 TRANSMITTER ADJUSTMENT (MODULE-TYPE)	6 - 8 ~ 10
	6-5 TRANSMITTER ADJUSTMENT (TRANSISTOR-TYPE)	6 - 11 ~ 13
SECTION	7 VOLTAGE/CIRCUIT DIAGRAMS	7 - 1 ~ 10
	7-1 FRONT UNIT, VR UNIT AND MIC UNIT	7 - 1
	7-2 DISPLAY UNIT	7 - 2
	7-3 MAIN UNIT	7 - 3
	7-4 PLL UNIT AND DOUBLER UNIT	7 - 4
	7-5 LOGIC UNIT (#02)	7 - 5
	7-5 LOGIC UNIT (#03, #04)	7 - 5
	7-6 VCC UNIT AND RAM UNIT, DC-DC UNIT	7 - 6
	7-7 IF UNIT	7 - 7
	7-8 FILTER UNIT AND RF MIX UNIT	7 - 8
	7-9 PA UNIT (MODULE-TYPE)	7 - 9
	7-10 PA UNIT (TRANSISTOR-TYPE)	7 - 10
SECTION	8 BOARD LAYOUTS	8 - 1 ~ 9
	8-1 FRONT UNIT (VR UNIT, MIC UNIT, DISPLAY UNIT)	8 - 1
	8-2 FRONT UNIT	8 - 2
	8-3 MAIN UNIT	8 - 3
	8-4 PLL UNIT	8 - 4
	8-5 LOGIC UNIT (#02)	8 - 5
	8-5 LOGIC UNIT (#03, #04)	8 - 5
	8-6 VCC UNIT, DC-DC UNIT (#02), DC-DC UNIT (#03, #04), JACK UNIT, DOUBLER UNIT, RAM UNIT (ON THE LOGIC UNIT)	8 - 6
	8-7 FILTER UNIT, IF UNIT, RF MIX UNIT	8 - 7
	8-8 PA UNIT (MODULE-TYPE)	8 - 8
	8-9 PA UNIT (TRANSISTOR-TYPE)	8 - 9
SECTION	9 IC SPECIFICATION	9 - 1 ~ 15
SECTION	10 PARTS LIST	10 - 1 ~ 31
SECTION	11 SCHEMATIC DIAGRAM (IC-1271A: #03, 04)	SEPARATE
SECTION	12 SCHEMATIC DIAGRAM (IC-1271E: #02)	SEPARATE
TV-1200 SERVICE MANUAL		APPENDIX

SECTION 1 SPECIFICATIONS

1-1 GENERAL

Frequency coverage	: 1240~1300MHz
Operating modes	: J3E (A3J) SSB (Upper and Lower Sideband) A1A (A1) CW F3E (F3) FM
Frequency resolution	: SSB, CW 100Hz FM 25kHz
Frequency control	: CPU based 100Hz step digital PLL synthesizer. Independent transmit/receive frequency available.
Frequency readout	: 7 digit, 1kHz display.
Usable temperature range	: $-10^{\circ}\text{C}\sim+60^{\circ}\text{C}$ ($+14^{\circ}\text{F}\sim+140^{\circ}\text{F}$)
Frequency stability	: Within $\pm 0.0003\%$ in the range of $0^{\circ}\text{C}\sim+50^{\circ}\text{C}$.
Memory channels	: 32 channels with any in-band frequency programmable.
Power supply requirements	: 13.8V DC $\pm 15\%$ (negative ground). Current drain 7.5A maximum.
Current drain (at 13.8V DC)	: Transmitting Approx. 7.5A Receiving At maximum audio output Approx. 1.5A Squelched Approx. 1.3A
Antenna impedance	: 50 ohms unbalanced.
Weight	: 7.1kg
Dimensions	: 111(127)mm(H) \times 286(303)mm(W) \times 276(348)mm(D) Bracketed values include projections.

1-2 TRANSMITTER

RF output power	: J3E (SSB) 10 watts PEP A1A (CW), F3E (FM) 10 watts Continuously adjustable output power from 1 to 10 watts.
Modulation system	: SSB: Balanced modulation. FM : Variable reactance frequency modulation.
Max. frequency deviation	: $\pm 5\text{kHz}$.
Spurious emissions	: More than 50dB below peak power output.
Carrier suppression	: More than 40dB below peak power output.
Unwanted sideband	: More than 40dB down with 1000Hz AF input.
Operating modes	: Simplex or semi-duplex.
Microphone	: 600 ohm electret condenser microphone with push-to-talk switch and scanning buttons.

1-3 RECEIVER

Receive system	: J3E (SSB), A1A (CW): Double conversion superheterodyne. F3E (FM) : Triple conversion superheterodyne.
Intermediate frequencies	: SSB, CW 1st : 133,8600~133.8699 MHz 2nd: 10.75MHz FM 1st : 133.860~133.869 MHz 2nd: 10.75MHz 3rd : 455kHz
Sensitivity	: SSB, CW: Less than $0.16\mu\text{V}$ for 10dB S+N/N. FM : Less than $0.22\mu\text{V}$ for 12dB SINAD. Less than $0.32\mu\text{V}$ for 20dB noise quieting.
Selectivity	: SSB, CW: More than 2.4kHz at -6dB point. Less than 4.8kHz at -60dB point. FM : More than 15kHz at -6dB point. Less than 30kHz at -60dB point.
Audio output	: More than 2 watts at 10% distortion with 8 ohm load.
Audio output impedance	: 8 ohms

SECTION 2 INSIDE AND OUTSIDE VIEWS

2-1 FRONT PANEL

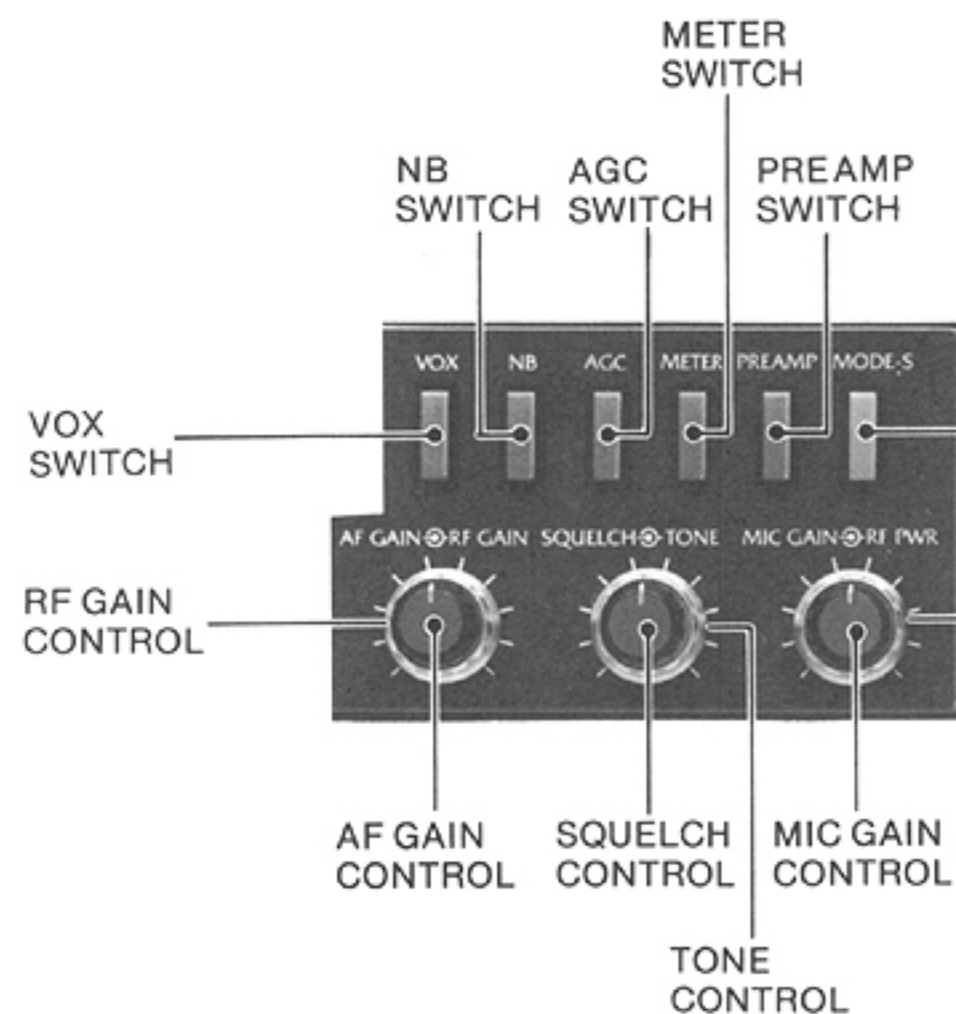
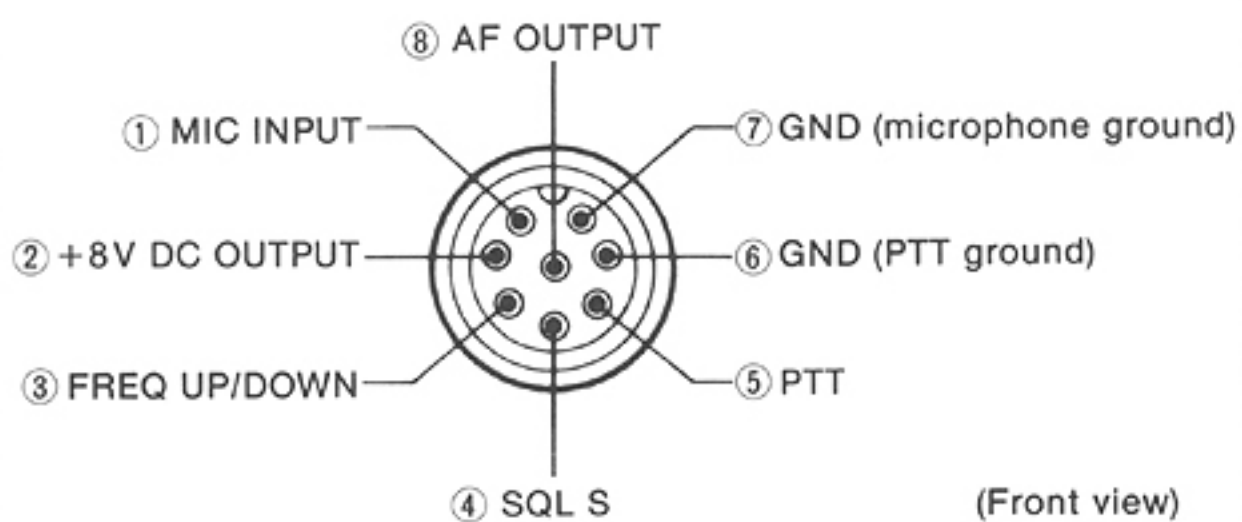
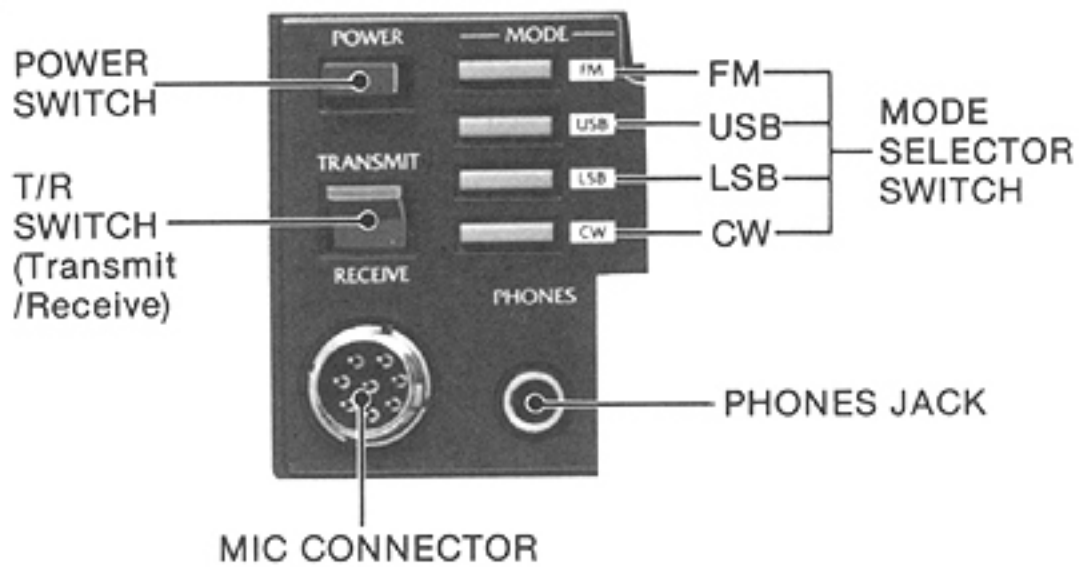
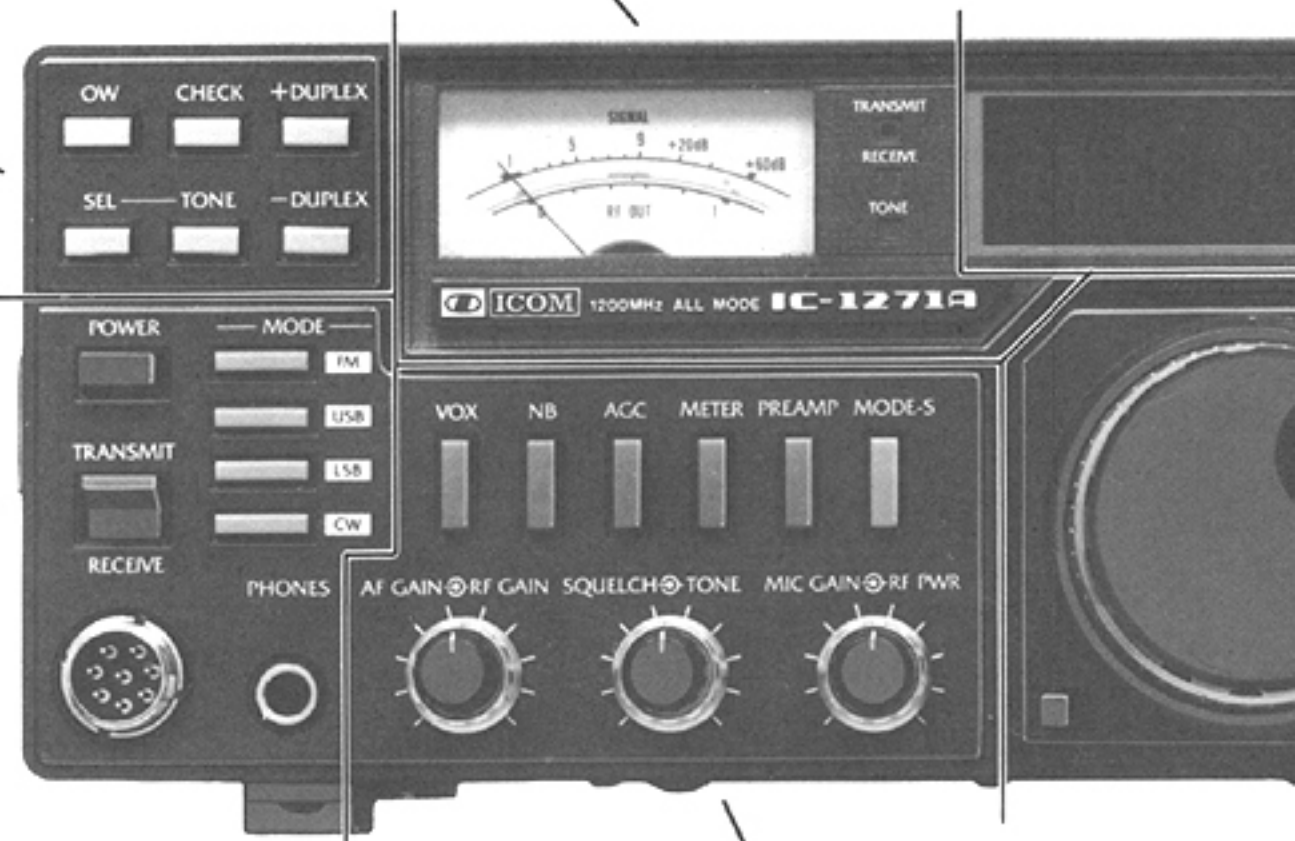
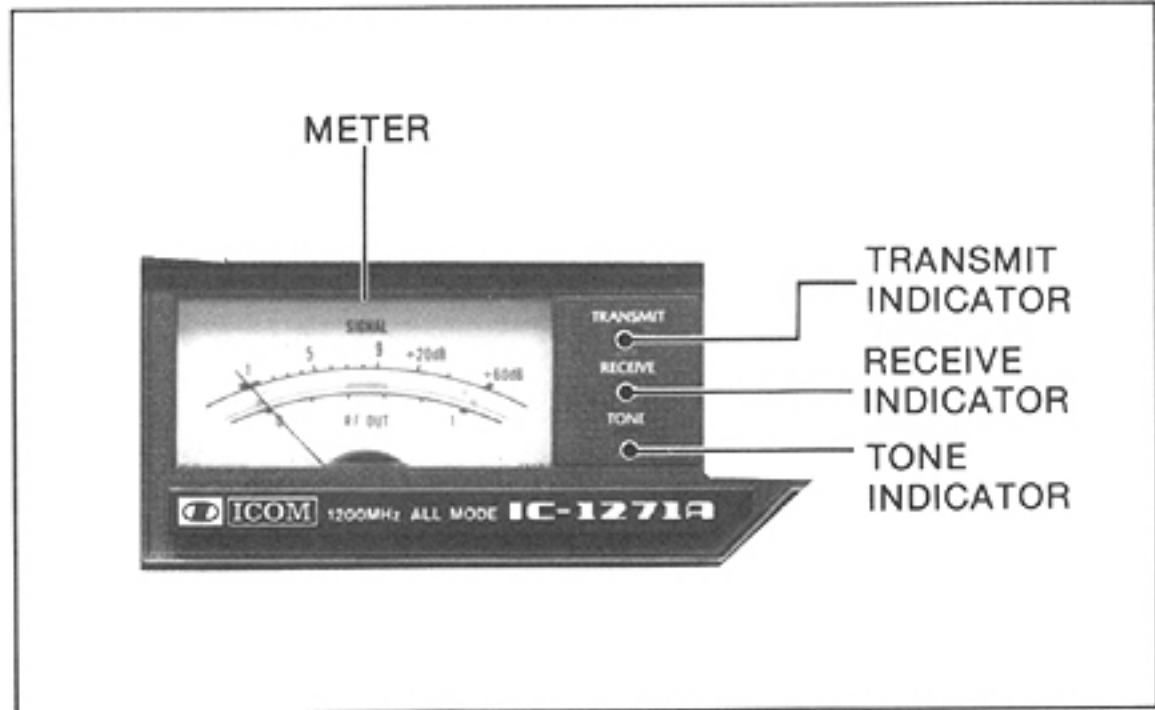
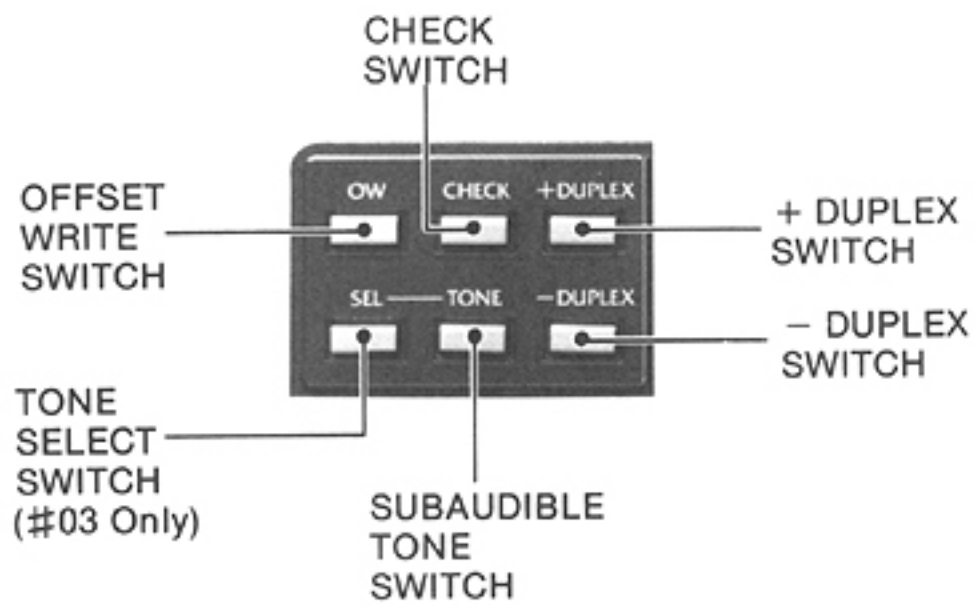

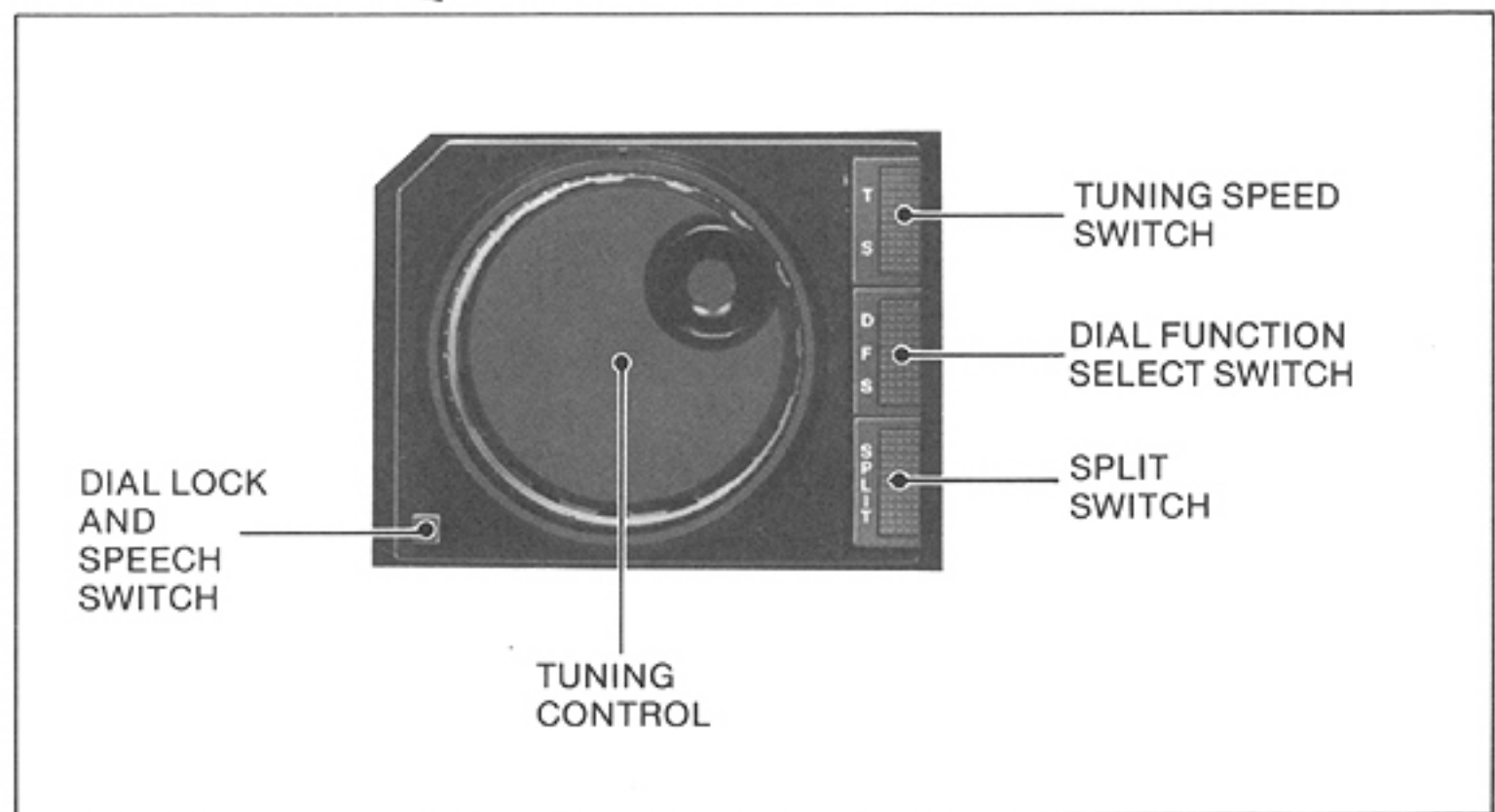
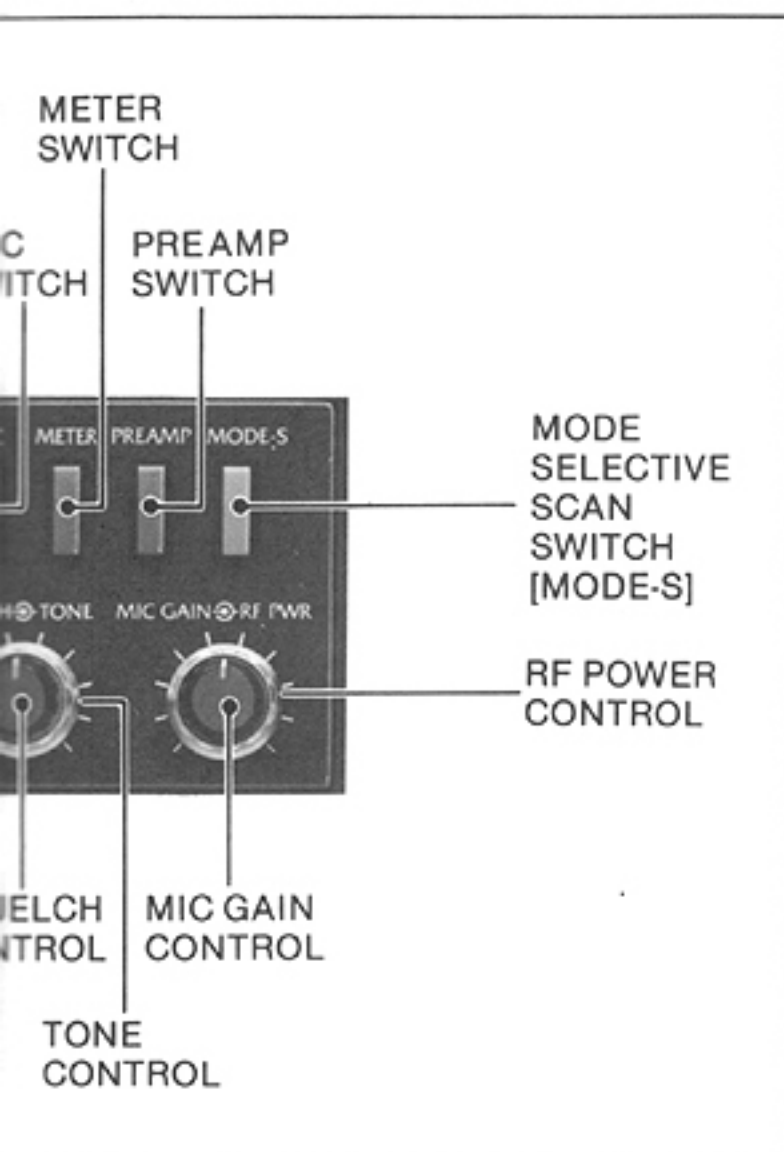
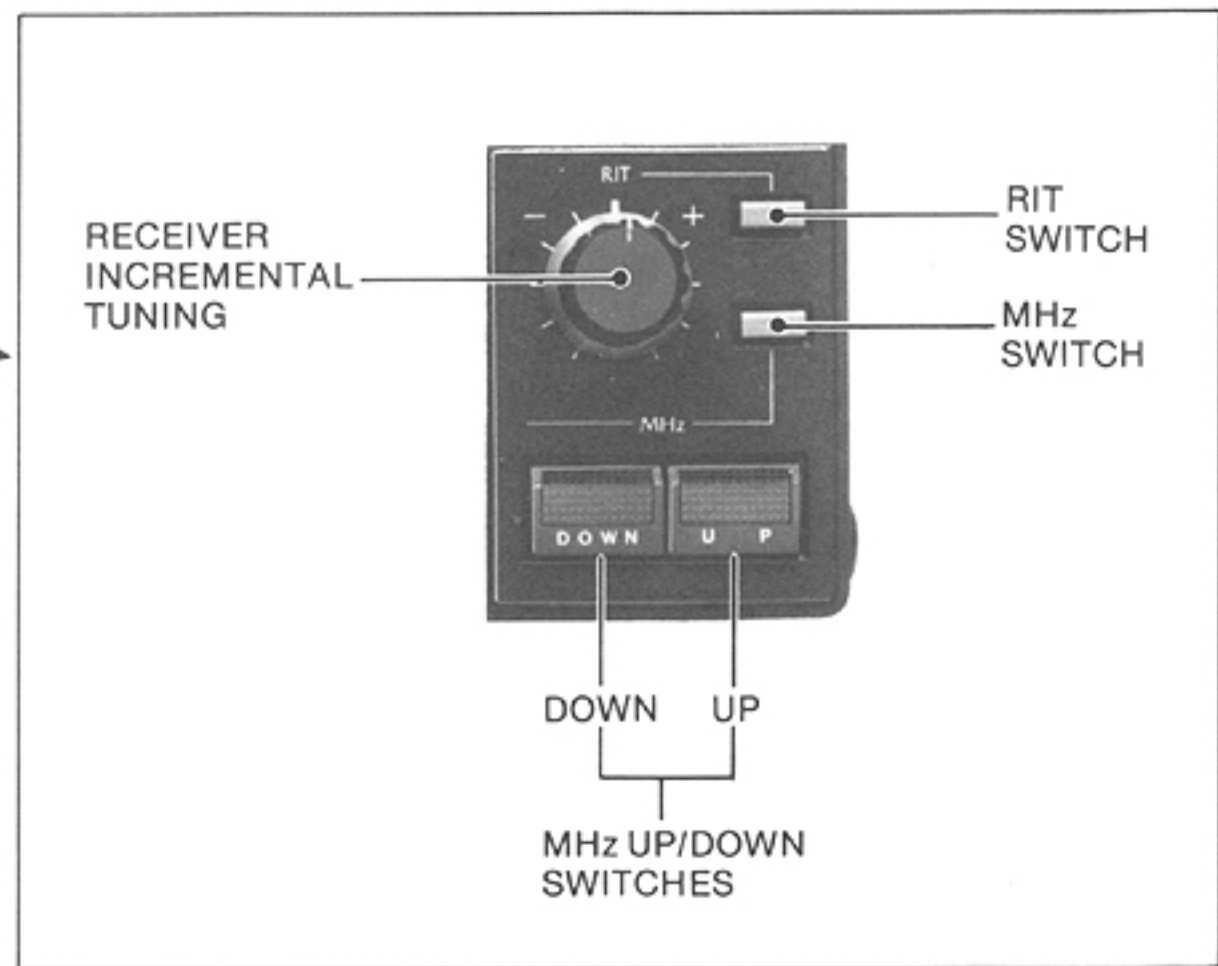
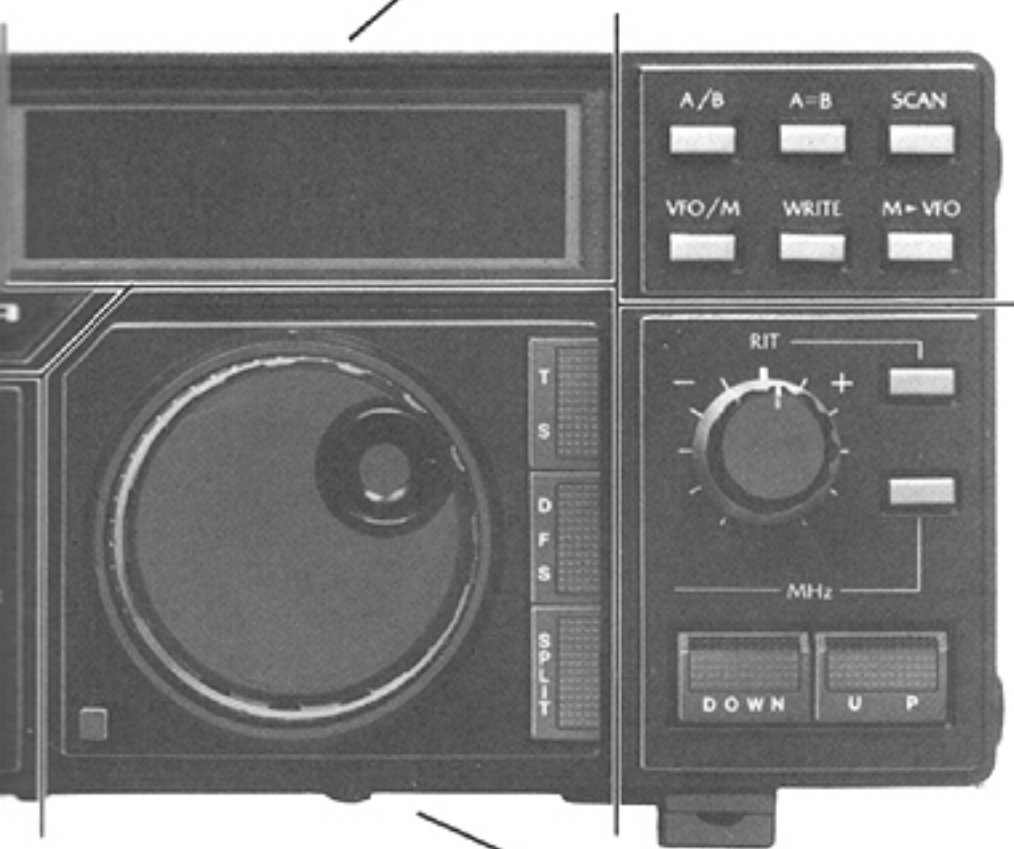
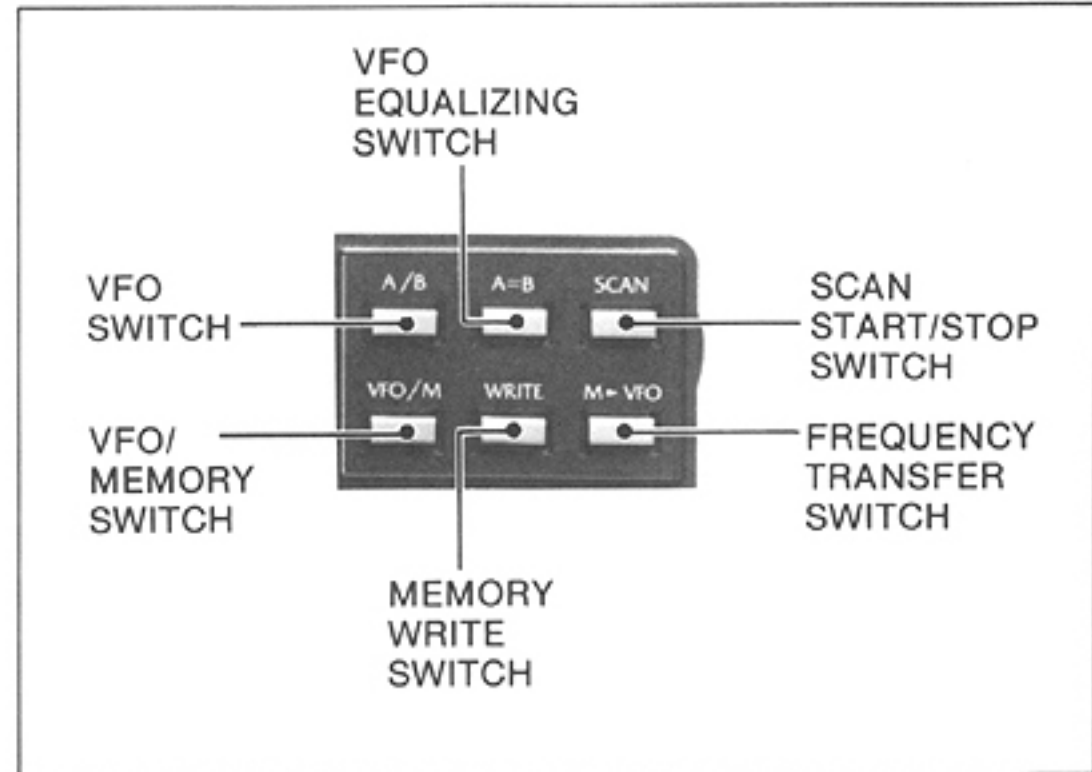
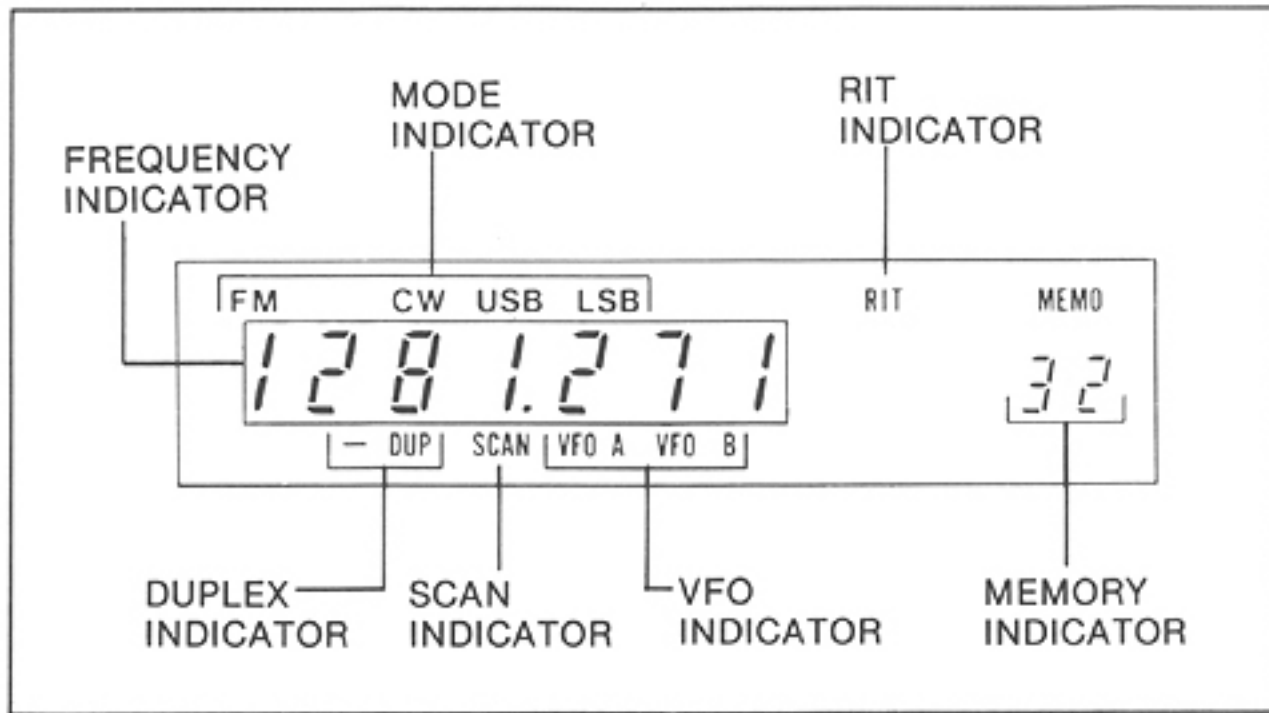

2-2 CONTROLS UNDER THE ACCESS COVER

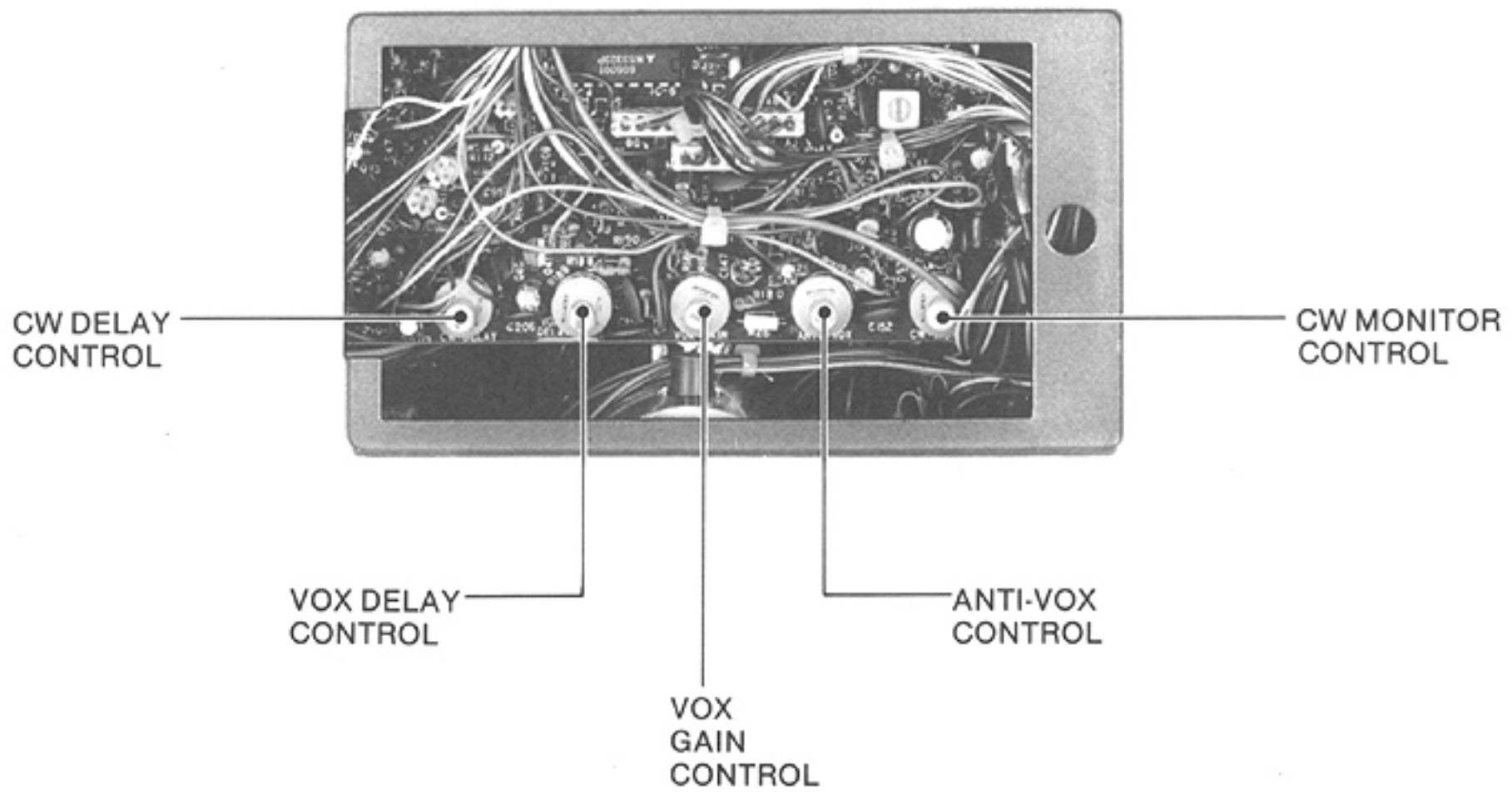

2-3 REAR PANEL

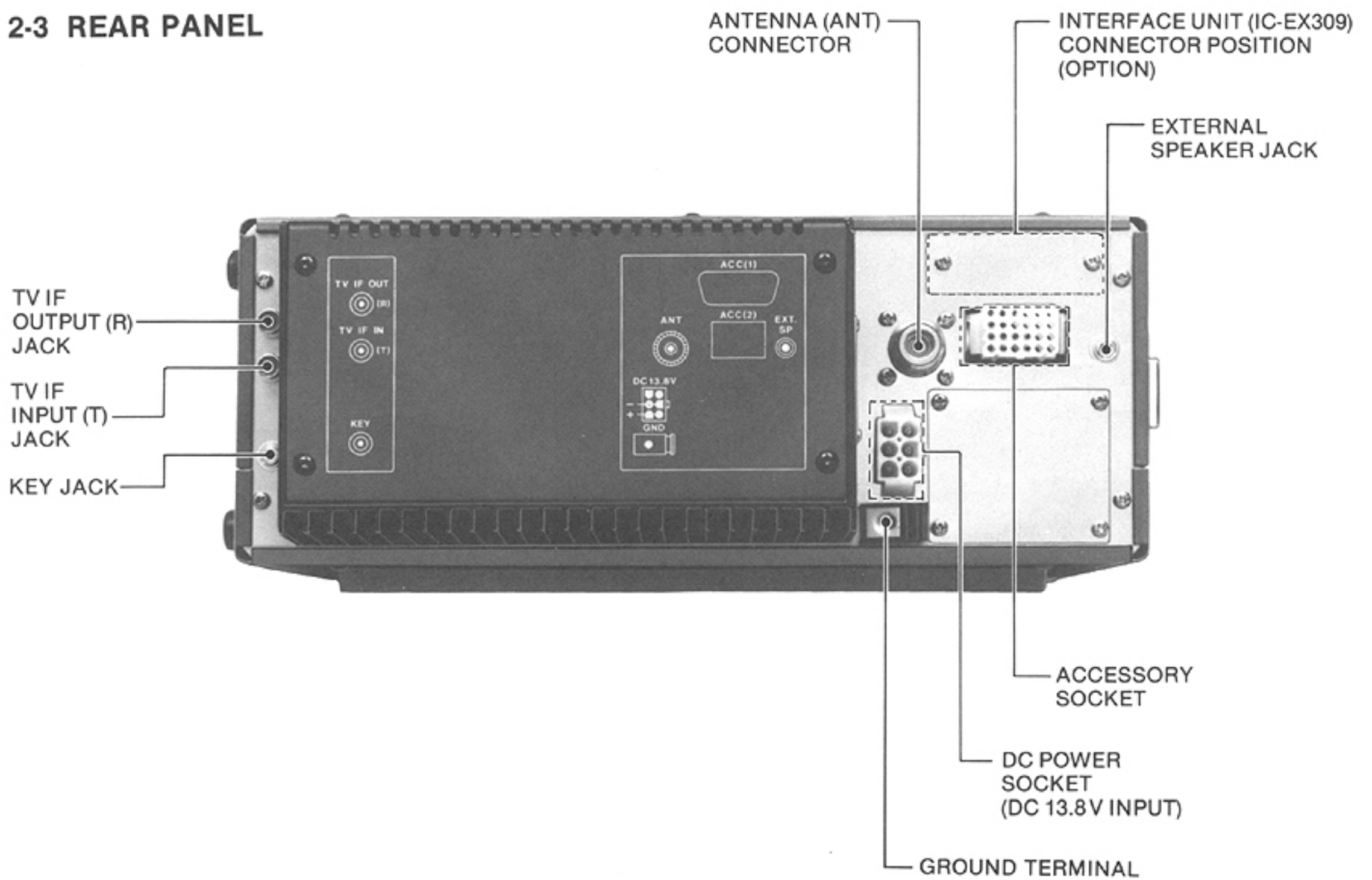

2-4 INSIDE TOP VIEW

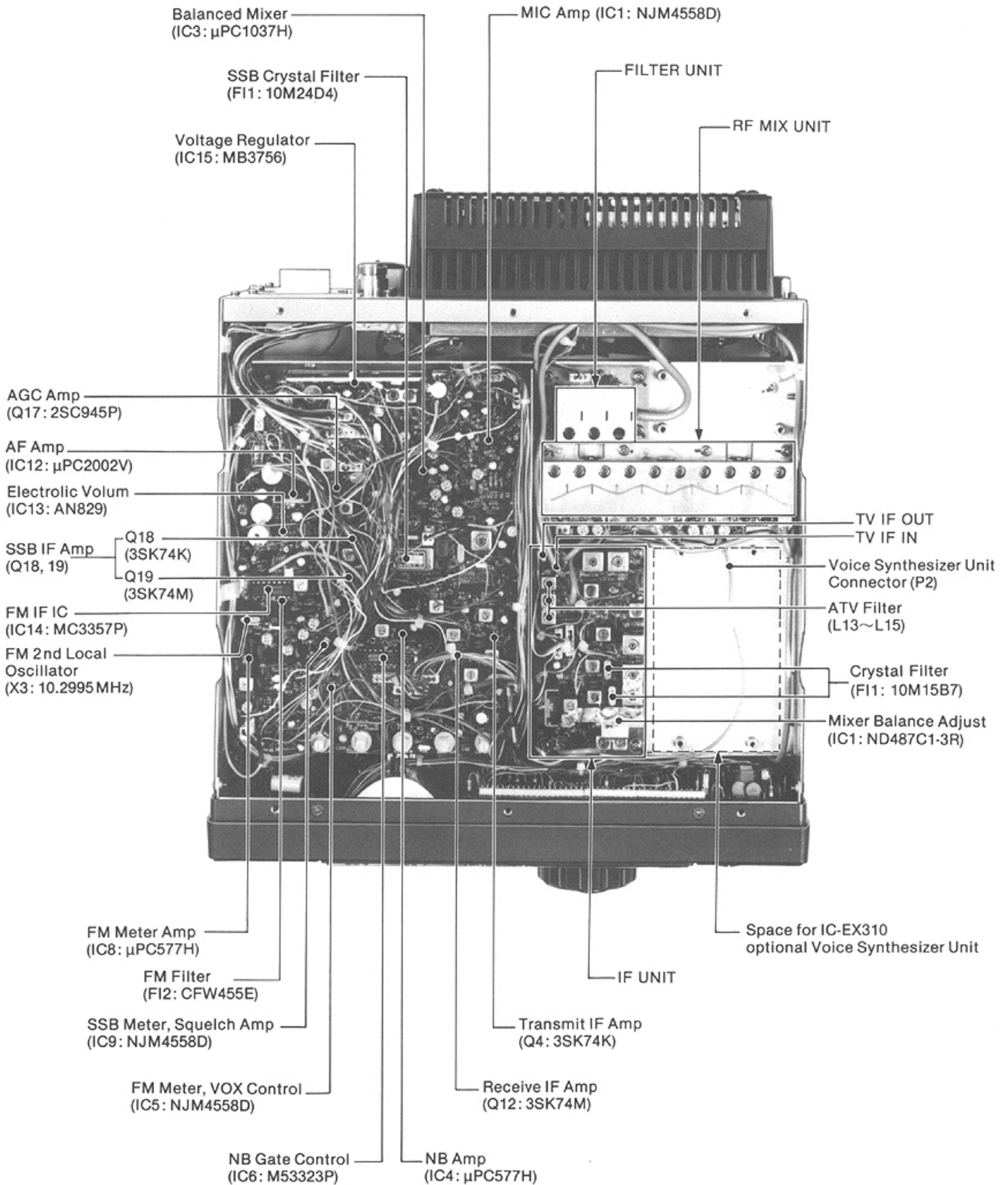

2-5 INSIDE BOTTOM VIEW

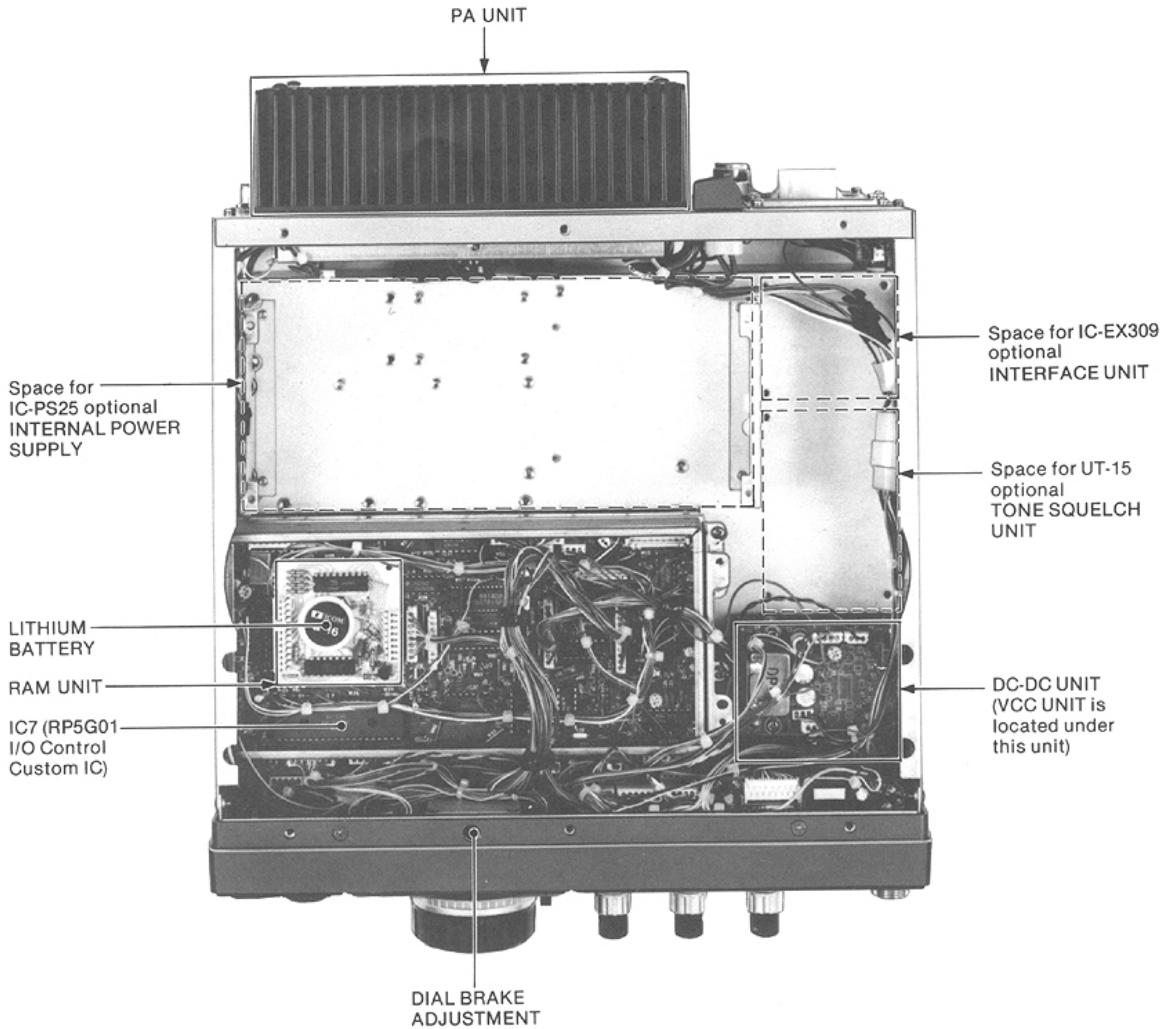

2-6 PLL UNIT (Located Under the LOGIC UNIT)

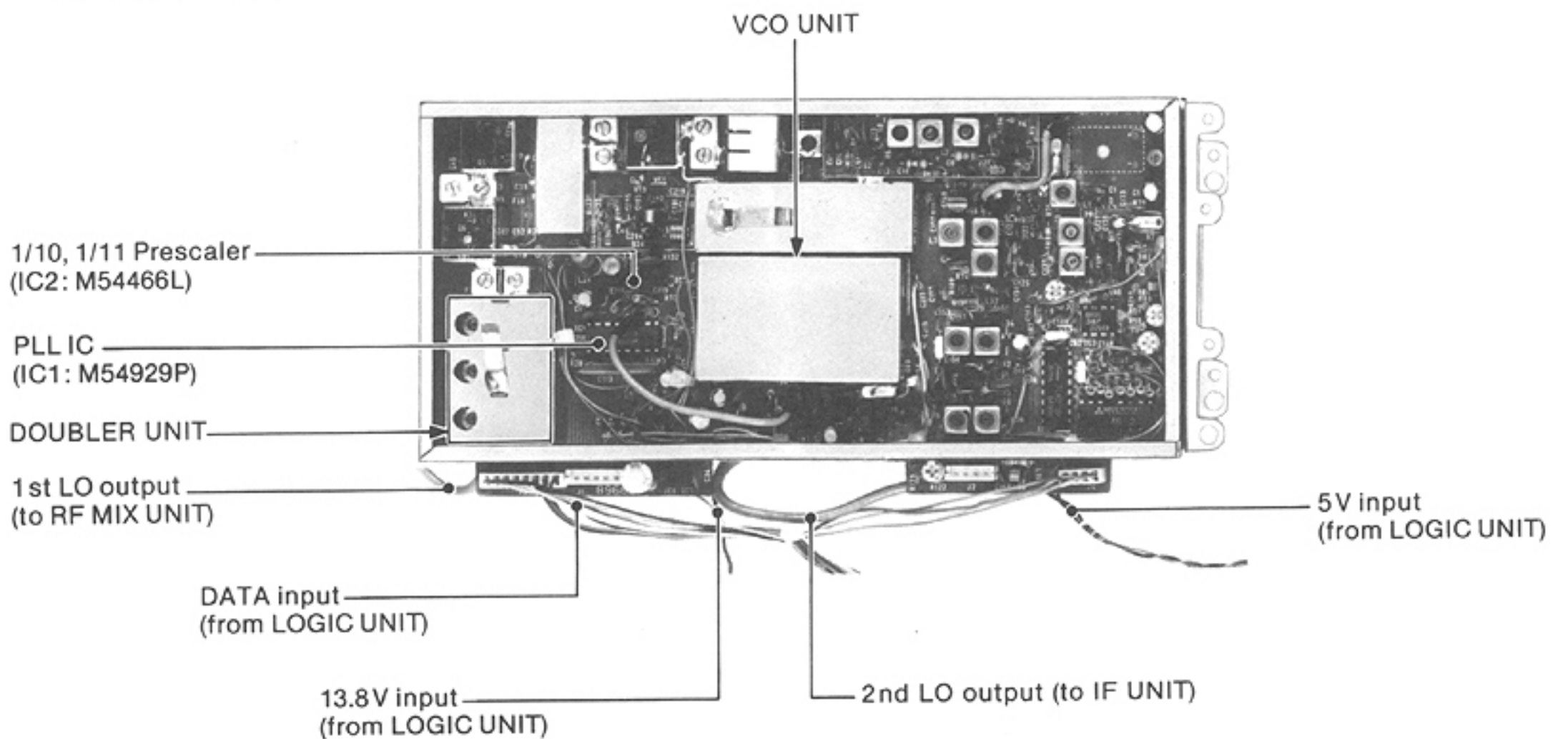

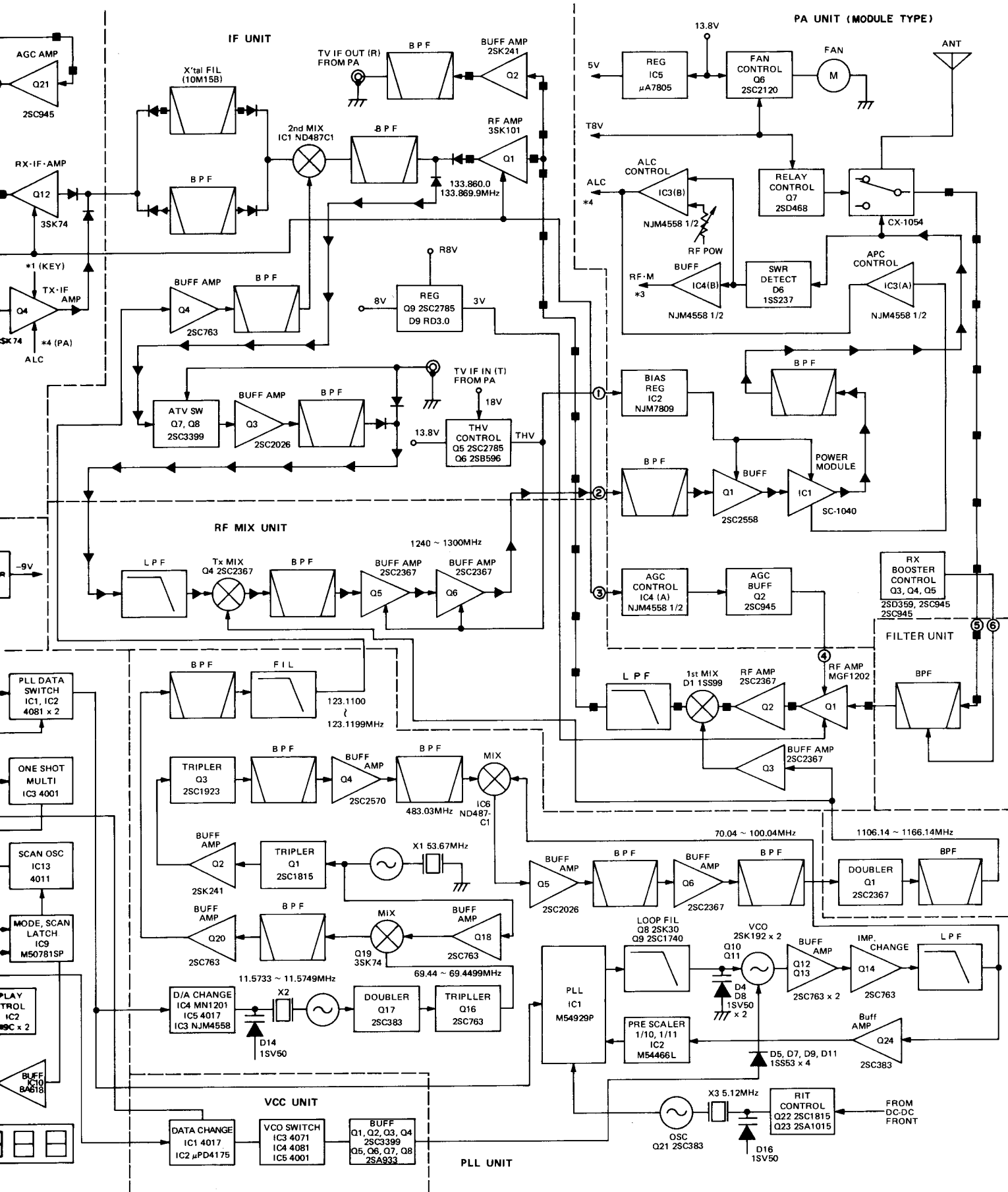

3-2 PA UNIT (TRANSISTOR-TYPE)

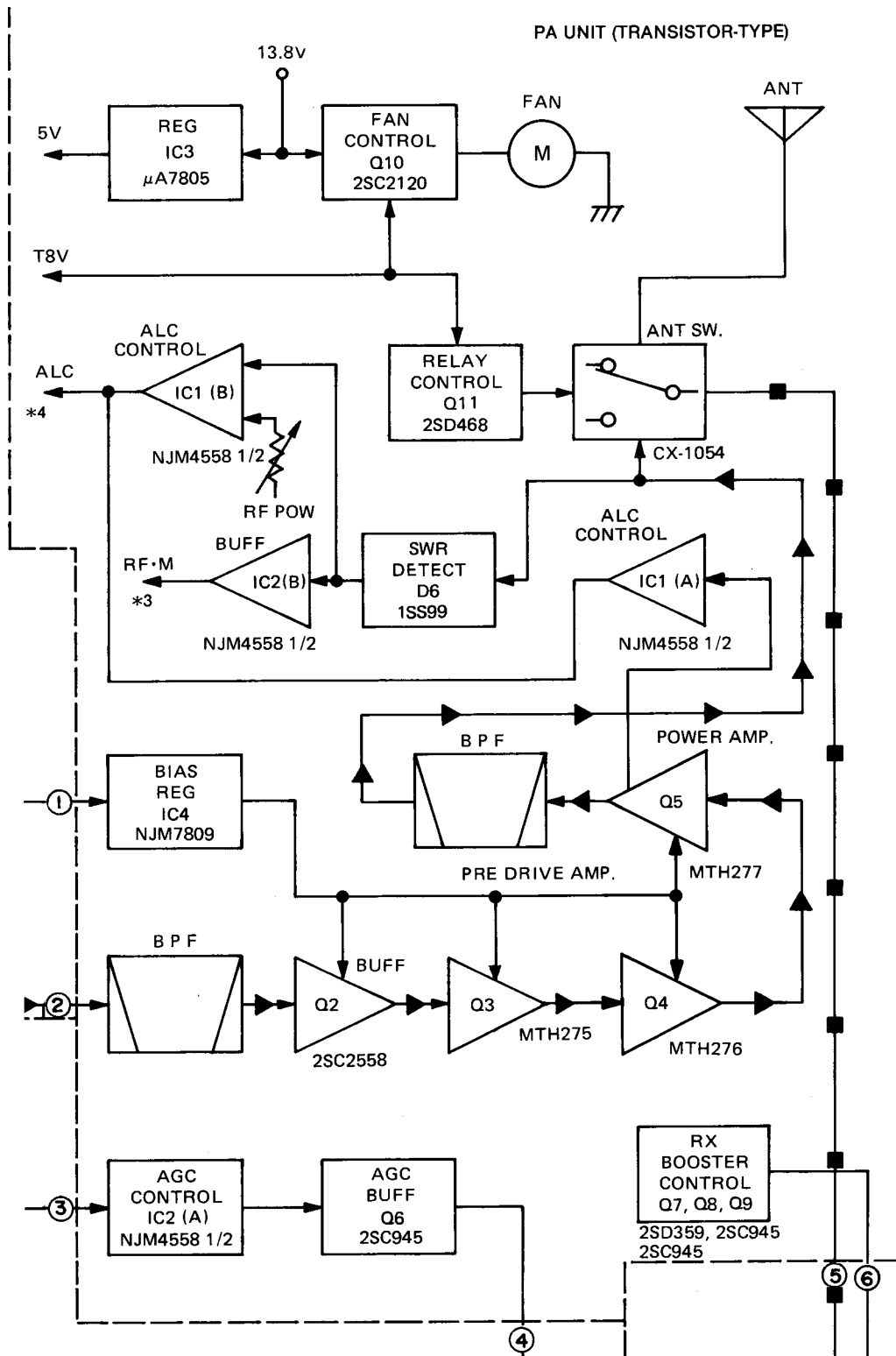

SECTION 4 CIRCUIT DESCRIPTION

4-1 RECEIVER CIRCUITS

4-1-1 TRANSMIT/RECEIVE SWITCHING CIRCUIT (PA UNIT)

As a high-class coaxial relay has been used in the transmit/receive switching circuit at the antenna terminal, it exhibits extremely outstanding characteristics of 30dB isolation or more and a pass loss of less than 0.5dB.

4-1-2 RF CIRCUIT (FILTER UNIT, RF MIX UNIT)

a) FILTER UNIT

The input signals of 1240~1300MHz from the ANT terminal enter the FILTER UNIT via a coaxial relay inside the PA UNIT, and RF signals outside the band are attenuated by a bandpass filter configured in a strip-line and applied to the RF MIX UNIT.

Also, in this unit, a power supply line is installed to operate the optional mast-mounted preamplifier (AG-1200).

b) RF MIX UNIT

RF signals that pass through the FILTER UNIT are added to J1 on the RF MIX UNIT and supplied to L6 by a pattern coil. RF signals supplied to L6 are added to Q1 and amplified. Q1 utilizes a high-gain, low NF excellent GaAs FET (MGF-1202), and the AGC voltage from J4 is applied to the source of Q1 to vary the gain when the transceiver is in any mode except FM.

RF signals which are amplified at Q2 after Q1, are applied to D1. They are then converted to a 1_{ST} intermediate frequency of 133.86MHz by the 1_{ST} LO signal from the PLL UNIT (1106.14~1166.14MHz, first-stage amplified by Q3) and the mixer diode, and are supplied to the IF UNIT via the low-pass filter.

4-1-3 INTERMEDIATE FREQUENCY CIRCUIT (IF UNIT)

133.86MHz signals output from the RF MIX UNIT enter the resonator circuit of L11 and C29. They are then amplified by Q2 via C28 when ATV (Amateur Television) is in operation, and are sent to the IF ATV OUT terminal via the bandpass filter. These signals are also amplified by Q1 and pass through the resonator circuit of L12 and C35 and through diode D6 for switching between the transmit and receive modes. At a bandpass filter comprised of L5, L6, L7, C5, C6, C7, C8 and C9 for combined transmit/receive use, they pass through a frequency of 133.86~133.869MHz, and are applied to the IC1 mixer for combined transmit/receive use.

The 123.11~123.119.9MHz second local oscillation signal applied from J3, is amplified by Q4, passes through a bandpass filter comprised of L18, L19, C60, C61 and C55, is mixed with 133.86~133.869MHz, and is

converted to 10.75MHz. The output from the mixer passes through diode D4 for transmit/receive switching, and frequencies other than 10.75MHz are attenuated by crystal filter FI1. The signal passes through diode D3 for transmit/receive switching and is supplied to the MAIN UNIT.

Q9 in the IF UNIT supplies power to Q1 (MGF1202) in the RF MIX UNIT. When transmitting and receiving, Q9 is turned ON by R8V and +8V are removed by the emitter follower and applied to the collector where they are stabilized to 3V by D9 and supplied to the RF MIX UNIT.

a) FM (MAIN UNIT)

2_{ND} IF signals from the IF UNIT pass through J10, and are amplified by Q12. The output from the drain enters the L11 tuned circuit and is then coupled to the FM IF circuit (IC14) via C92.

IC14 incorporates the 3_{RD} LO, the 3_{RD} mixer, a limiter amplifier, a quadrature detector and an active filter in a single package. Since the number of externally connected parts is few, the reliability of this stage is high.

The 2_{ND} intermediate frequency enters IC14 (pin 16) and mixes with the 3_{RD} oscillator frequency generated by crystal X3 (10.295MHz), C175 and C176, which are connected across pins 1 and 2.

A 455kHz 3_{RD} intermediate frequency signal is then output from pin 3. The signal from pin 3 passes through a high performance ceramic filter (F12), enters pin 5, passes through a limiter amplifier and then exits from pin 7. The L18 quadrature coil and the IC's internal quadrature detector both detect and amplify the output from pin 7. The resulting audio signal (310mV rms) is output from pin 9.

b) SSB (MAIN UNIT)

In the SSB mode, Q12 also amplifies the signal from the IF UNIT in the same manner as an FM signal. The signal then passes from the Q12 drain through C82 and L9 to the SSB crystal filter (FI1) which has a selectivity of 2.2kHz (-6dB). This signal is amplified by two dual-gate MOSFET IF amplifiers (Q18, Q19) in separate stages since stability and high gain/wide AGC range characteristics are required. L14 and L15 provide added frequency selectivity for further filtering of wideband noise and strong interference.

AGC voltage is also applied to the second gate of each MOSFET in order to expand the AGC range. By applying the AGC voltage, a drop in the source voltage of Q18 is used to control the signal to IC9B (SSB and S-meter amplifier) which provides the output that con-

trols the S-meter movement. R160 is the SSB S5 adjustment and R164 is the full-scale adjustment.

Part of the receive signal is further amplified by the AGC buffer amplifier at Q17, tuned at L13, AGC-rectified at D36 and D37, and AGC DC-amplified at (Q16). Q16 supplies voltage of +8V and -9V in order to expand the AGC range. R118, R117, C97 and C98 integrate the voltage from Q16, and the attack time constant is set by R19 in the IF UNIT. The AGC voltage produced is supplied to each stage of the receiver.

The AGC voltage is also supplied from the front panel to the RF GAIN CONTROL. If the front panel AGC SWITCH is set to FAST, C97 and R117 are switched OUT and the release time becomes shorter. The FRONT UNIT supplies +8V when the AGC SWITCH is set to FAST. Q14 and Q15 switch ON when the AGC voltage reaches 0.6V or more during release, thus speeding up the release time.

The other portion of the receive signal is coupled by C55 into a double-balanced demodulator (IC3). Here it is demodulated by the BFO signal input to pin 7. The demodulated audio signal, coupled by C65, passes to the audio amplifier Q30.

4-1-4 BFO CIRCUIT (MAIN UNIT)

The BFO circuit consists of Q5, Q6, Q7 and X2 and changes its oscillation frequency depending on the mode selected. The frequencies for the different modes are:

USB: 10.7485MHz
LSB: 10.7515MHz
CW•R: 10.7485MHz
CW•T: 10.7493MHz

The various frequencies are switched by D17, D18, D19, D20 and Q5 according to the position of the MODE SWITCH on the front panel which connects L7 and L8 in series with crystal X2.

In this BFO circuit the frequencies are generated by Q6, amplified by buffer Q7, coupled through C53 and input to IC3 (pin 7).

4-1-5 NOISE BLANKER CIRCUIT (MAIN UNIT)

IF signals from Q12 are introduced to the noise blanker circuit by C88.

The purpose of the noise blanker circuit is to remove pulse-type noise that interferes with the desired receive signal.

The noise amplified by IC4 is rectified by D29 and D30. Part of these rectified signals are amplified by Q21 and integrated by C90. Output from IC14 is held at a constant level as the AGC voltage of IC4.

The other part of the rectified signals are supplied to the base of Q20.

When pulse-type noise is received, Q30 turns ON and the comparator drops to ground level, thereby triggering the monostable multivibrator, IC6. R141 switches Q11 ON, D26 switches ON, D27 becomes reverse-biased and the signal to the SBB circuit is blocked. IC7 is a three-terminal regulator used to supply +5V to IC6 (TTL).

The noise blanker functions only while in the SSB mode.

4-1-6 AUDIO FREQUENCY CIRCUIT, FM SQUELCH CIRCUIT (MAIN UNIT)

Q30 amplifies the audio output from IC14 (pin 9) and then passes the output to IC13A which is used for DC control of the audio frequency. The output from pin 9 is also supplied to IC13B and used for the DC controlled squelch. Both of these control signals may be controlled externally through the use of the ACC socket.

AF DC control signals are fed to the AF power amplifier (IC12) which raises the level sufficiently to drive the speaker. IC12 is a high-output (2W or more with an 8Ω load), low-distortion audio IC that contains various protection circuits.

Squelch signals controlled by IC13B are again input at IC14 (pin 10) which amplifies the portion of the signals greater than 70kHz with an active filter, and then outputs the result from pin 11.

Noise signals are rectified by D60 and D61, and Q31 is switched ON.

Because of this, the collector side of Q31 drops virtually to ground level, and D58 causes IC13A (pin 13) also to drop to ground level.

Audio signals are blocked by IC13A, therefore the audio output is the same as when the audio volume is set to the minimum level.

D58 prevents reverse flow and R210 sets the squelch operating point.

Since Q31 prevents any residual noise from IC13A from being output from the speaker during transmission, T8V is applied via D65 and R226, thus switching Q31 ON and dropping the collector side to ground level.

4-1-7 SSB SQUELCH CIRCUIT (MAIN UNIT)

IC9A functions as a comparator. The S-meter signal and voltage from the SQUELCH CONTROL both feed into IC9A R220, R222 and R224. The SQUELCH CONTROL divides a fixed 8V level and the result is applied to the positive (+) IC9A (pin 3) input terminal.

This voltage becomes the comparator's reference voltage. R221 and R223 divide the difference between 8V and the S-meter signal voltage, and the result is applied to the negative (-) IC9A (pin 2) input terminal.

Thus, if the voltage at pin 2 is higher than the voltage at pin 3 (the input signal exceeds the designated level), pin 1, which is the output terminal, drops from 8V to approximately 0V.

This causes the cathode side of D62 to drop, Q42 to switch OFF, and the squelch to open. While operating FM, 8V are applied to pin 2 of IC9A through D64 and pin 1 becomes LOW, thus preventing the control of Q42.

4-1-8 S-RF METER CIRCUIT (MAIN UNIT)

While transmitting, the RF meter signal from the PA UNIT is supplied to the meter via R240. While receiving in FM mode, C125 couples the 455kHz output from FI2 to the FM S-meter amplifier (IC8). After IC8 amplifies the signal, it is rectified by D43 and D44 and supplied to the meter.

Q24 acts as the AGC for the S-meter amplifier.

While receiving in SSB mode signals are input to IC9B from the IF amplifier source (Q18) via R164.

The signals are amplified by IC9B and then supplied to the meter.

Available controls are:

CONTROL	MODE	FUNCTION
R240	Transmit	RF meter adjustment
R149	FM receive	S9 meter adjustment
R152	FM receive	Full-scale meter adjustment
R160	SSB receive	S5 meter adjustment
R164	SSB receive	Full-scale meter adjustment

4-1-9 FM CENTER METER CIRCUIT (MAIN UNIT)

The center meter amplifier (IC5B) receives signals from IC14 (pin 9) via R206.

R109, R112 and R113 divide a fixed +8V, and the divided voltage is supplied to IC5B (pin 5).

The reference voltage is compared with the IC14 output voltage and the difference is passed from IC5B (pin 7). Q13 is a switching transistor for the S-meter and the center meter.

Controls available are:

CONTROL	FUNCTION
R113	Center adjustment
R114	Full-scale meter adjustment

4-1-10 OTHER CIRCUITS

a) POWER SOURCE CIRCUIT (MAIN UNIT)

IC15 is an IC for the power source that incorporates various protection circuits, reduces the number of parts, and causes a drop in the failure rate.

Constant voltages 8V (pin 1), R8V (pin 6), and T8V (pin 8) are output respectively to pins when 13.8V (pin 2) is input. R8V and T8V are switched by dropping the voltage of pin 5 to ground level.

As mute voltage from the PLL is applied to the base of Q33, T8V is output when the emitter (SEND line) drops to ground level.

Also, as the mute voltage becomes LOW when the PLL is unlocked, Q33 is not switched ON and T8V is not output.

b) RF-AGC CIRCUIT (PA UNIT)

TRANSISTOR-TYPE

IC2A is an AGC circuit installed exclusively for Q1 within the RF MIX UNIT. The AGC voltage output from the IF UNIT is amplified, and the AGC characteristics are the same as those for other amplifiers. The output from IC2A is buffer amplified by Q6, and is then output to the Q1 on the RF MIX UNIT as the AGC voltage.

MODULE-TYPE

IC4A is an AGC circuit installed exclusively for Q1 on the RF MIX UNIT. The AGC voltage output from the IF UNIT is amplified, and the AGC characteristics are the same as those for other amplifiers. The output from IC4A is buffer amplified by Q2, and is then output to Q1 on the RF MIX UNIT as the AGC voltage.

c) FAN MOTOR CONTROL CIRCUIT (PA UNIT)

TRANSISTOR-TYPE

During reception, a current of approximately 20mA is supplied to the fan motor from R45 and R50 to lightly rotate the fan.

During transmission R50 is shorted when Q10 is turned ON and R45 operates at approximately 60mA to supply power for high speed rotation.

MODULE-TYPE

During reception, a current of approximately 20mA is supplied to the fan motor from R39 and R41 to lightly rotate the fan.

During transmission R39 is shorted when Q6 is turned ON, and when R41 is operated, approximately 60mA is supplied for high speed rotation.

4-2 TRANSMITTER CIRCUITS

4-2-1 AUDIO FREQUENCY AMPLIFIER AND LIMITER CIRCUITS (MAIN UNIT)

Audio signals from the microphone are amplified by IC1A, differentiated by C7 and R12 and input to IC1B. The portion of the audio signals from 300Hz to 3kHz is limiter-amplified with an emphasis of 6dB/octave. As the output contains high frequency components, the splatter filter (Q1) removes the frequencies above 3kHz. The spread of unwanted signals are suppressed, and the signal is then fed to varactor diode D4 for frequency modulation.

In the SSB mode, R27 and C61 integrate the signals with a deemphasis of 6dB/octave, resulting in signals with flat response.

Q6 is a buffer amplifier which supplies its output to the SSB double-balanced modulator (IC3).

4-2-2 MODULATION CIRCUIT (MAIN UNIT)

a) FM CIRCUIT

The output from splatter filter Q1 varies the capacitance of varactor diode D4. The local oscillator frequency (10.75MHz) generated by X1 and Q3 for the FM mode is modulated by the output from D4.

R29 is a variable resistor for setting the required deviation (± 4.8 kHz).

In addition, a thermistor (R32) is connected to the FM circuit in order to provide temperature compensation. The output from this FM circuit is limiter-amplified by IC2 and input to Q4.

b) SSB MODULATION AND BUFFER AMPLIFIER CIRCUITS

Audio frequency signals amplified by buffer Q9 are input to IC3 (pin 5) via R82.

Also, BFO signals corresponding to the mode are input to IC3 (pin 7). The modulated DSB signals are output from the AF signal to IC3 (pin 5).

While transmitting CW, CW-T8V are applied via R70, thus upsetting the balance of IC3, and the BFO signals are output directly.

Because R8V is applied to the base of Q5 during reception, CW-T8V is applied only while transmitting.

Controls available are:

CONTROL	FUNCTION
R82	SSB output power
R63	CW output power

The output from IC3 (pin 2) feeds to Q10 where it is buffer amplified, and then input to crystal filter F11. F11 has a selectivity of 2.2kHz (-6 dB). The USB, LSB or CW output from the filter passes to Q4. After buffer amplification, the signals are supplied to the IF UNIT from J10.

4-2-3 BUFFER AMPLIFICATION CIRCUIT (MAIN UNIT)

SSB and CW signals pass through D31 and D6 where as FM signals pass through D5. The signals are then buffer-amplified by Q4 and supplied to the IF UNIT from J10.

Also, the power control voltage is applied to the first gate of Q4 from IC10, thus providing control of the RF power.

4-2-4 VOX CONTROL AND CW BREAK-IN CIRCUITS (MAIN UNIT)

The modulated signal from the microphone, amplified by IC5A, passes through R182 and is then audio frequency amplified by IC11B.

The output from IC11B sequentially switches ON Q27, Q41, Q40 and Q39, and the SEND line is switched to ground level, placing the transceiver in the transmit mode.

If there is no modulated signal and Q27 switches OFF, Q41, Q40, and Q39 remain ON to act as a VOX delay until C148 is discharged by R188 and R189.

Additionally, part of the output of the audio power amplifier (IC12B) is inversion-amplified by IC11A via R196. Q28 and Q29 switch ON, and the modulated signal input to IC11B is muted as anti-VOX.

After Q28 switches OFF, Q29 is delayed from switching OFF by the time constant of R191 and C149.

If the key is closed while the VOX circuit is activated, Q36, Q37, Q38 and Q39 switch ON, the SEND line is switched to ground level, and the transceiver enters the transmit mode.

When the key is opened, Q36 and Q37 switch OFF but Q38 remains ON until C203 discharges. R256 and R257 provide the necessary time constant for the CW delay.

Controls available are:

CONTROL	FUNCTION
R182	VOX gain adjustment
R189	VOX delay adjustment
R196	Anti-VOX adjustment
R257	CW delay adjustment

4-2-5 CW MONITOR CIRCUIT (MAIN UNIT)

When the transceiver is in the CW mode, CW-8V is supplied to the CW monitor circuit (Q34 and Q35).

While receiving, CW-8V is applied to the base of Q35 via R241 and R253, Q35 switches ON, and the Q34 phase oscillator stops oscillating.

When the key is closed, Q35 switches OFF and the Q34 phase oscillator begins to oscillate at a frequency of approximately 800Hz. R244 adjusts the level, and C205 couples the signal to the audio power amplifier (IC12) which feeds signals to the speaker for monitoring purposes while CW is being transmitted.

A constant 13.8V is applied to the audio power amplifier (IC12).

4-2-6 TRANSMITTER MIXER AND BUFFER AMPLIFIER (IF UNIT, RF MIX UNIT)

10.75MHz signals output from the MAIN UNIT pass through D1 for transmit/receive switching via P2, pass through a bandpass filter comprised of L1, L2 and C2, and then pass through D2 for transmit/receive switching. They then enter the mixer, IC1. The output mixed with the 2ND LO signal from the PLL UNIT passes through a bandpass filter where only 1ST IF of 133.86 ~133.869.9MHz are passed.

Then, they pass through D5 for transmit/receive switching are amplified by Q3 via resonator circuits L8 and C20, pass through a bandpass filter comprised of L9, L10, C24, C25 and C26, and then pass through D8 for ATV selection where they are applied to the RF MIX UNIT.

Additionally, DC Voltage is applied to the signal output from J7 while ATV is in operation. D7, Q7 and Q8 are then turned ON and the ATV signal is supplied to the RF MIX UNIT.

At this time, D8 is turned OFF, and the signal from the MAIN UNIT is cut by Q7, Q8 and D8.

The IF output signal (133.86MHz) from the IF UNIT is applied to the RF MIX UNIT, and is supplied to the base of Q4 from C18 via a low-pass filter consisting of C39, L2 and C16.

Here it is resonated at C17 and L11 via C15, and is mixed with 1ST LO signals applied to the base of Q4 via C19. It is then converted to 1240MHz~1300MHz, and further passed through a bandpass filter consisting of C21, L12 and C22, L13, after which it is amplified to approximately 160mW by Q5 and Q6, and supplied to the PA UNIT from J3.

4-2-7 POWER AMPLIFIER (PA UNIT)

TRANSISTOR-TYPE

The power (approximately 160mW) supplied from the RF MIX UNIT by P2 passes through a BPF to sufficiently attenuate spurious radiation outside the band. Then at four power stages (Q2, Q3, Q4, and Q5) power is amplified to approximately 16W. Then, it is once again passed through the BPF to further remove any spurious radiation, and supplied to the antenna terminals via the antenna selector (coaxial relay).

MODULE-TYPE

The voltage (approximately 160mW) power supplied from the RF MIX UNIT by P1 passes through a BPF where spurious radiation is sufficiently attenuated. It is then amplified to least. 19W at power stages Q1 and IC1. IC1 is an all-mode power module (SC-1040) for use in IC-1271. By using this IC, stable characteristics can be obtained at high output. The signal output from IC1 is spurious radiation-attenuated via the BPF and supplies power to the antenna terminal via the coaxial relay.

4-2-8 ALC DETECTION AND APC CIRCUITS (PA UNIT) TRANSISTOR-TYPE

Signals passed through the output side BPF enter the SWR detection circuit made by the strip-line. Travelling waves only are detected by D6, are rectified and smoothed out, and are supplied to IC1B and IC2B.

At IC1B, when this voltage and the RF POWER CONTROL on the front panel are altered, the power is controlled by comparing the resultant voltage by the differential amplifier. High power is set by R36, and low power by R35.

If an overcurrent flows to final transistor Q5 due to mismatching, etc., IC1B is set by R48 at the circuit for preventing transistor damage by detection of the potential difference occurring at R9. IC2B is the buffer amplifier for RF Meter operation.

MODULE-TYPE

Signals passed through the output side BPF enter the SWR detection circuit made by the strip-line. Forward waves only are detected by D2, are rectified and smoothed out, and are supplied to IC3B and IC4B.

At IC3B, when this voltage and the RF POWER CONTROL on the front panel are altered, the power is controlled by comparing the resultant voltage by the differential amplifier.

If an overcurrent flows to the final IC1 due to mismatching, etc., IC4B is the circuit for preventing IC1 damage by detection of the potential difference occurring at R3.

4-2-9 OTHER CIRCUITS

a) POWER SOURCE FOR ANTENNA PERPENDICULAR-TYPE PREAMPLIFIER (PA UNIT)

TRANSISTOR-TYPE

This circuit is comprised of Q7, Q8 and Q9, and supplies approximately 11V, 200mA.

MODULE-TYPE

This circuit is comprised of Q3, Q4 and Q5, and supplies approximately 11V, 200mA.

b) COAXIAL RELAY DRIVE CIRCUIT (PA UNIT)

TRANSISTOR-TYPE

When T8V is applied to the base of Q11 during transmission, this drive circuit turns the coaxial relay ON. D7 is a diode for absorbing inverse starting power.

MODULE-TYPE

When T8V is applied to the base of Q7 during transmission, this drive circuit turns the coaxial relay ON. D3 is a diode for absorbing inverse starting power.

c) THV (TRANSMIT 13.8V) CIRCUIT (IF UNIT)

Q5 and Q6 in the IF UNIT are turned ON by T8V in order to supply a voltage of approximately 13 volts to the RF MIX and PA UNITS during transmission. 13.8V are applied to emitter Q6 and are supplied to both units as THV from the collector.

d) TONE CALL (1750Hz) CIRCUIT (#02)
(DC-DC UNIT)

This circuit is composed of IC1, IC2A, X1 and R4. When the TONE SWITCH on the FRONT PANEL is pushed, Q1 switches ON and then a constant 8V DC from IC4 is supplied to pin 5 of IC1. IC1 is preset for 1750Hz and outputs the tone signals from pin 4. The 1750Hz tone output level is controlled by R4. The signals are amplified by IC2A and applied to D4 (FM modulator: MAIN UNIT).

At the same time, the voltage of pin 6 (IC2B) is dropped to ground level when D2 is switched ON. The output signals from pin 7 (IC2B) are applied to FRONT UNIT P15 via IC10 (Buffer AMP.: LOGIC UNIT). During the signals is applied, D30 (TONE INDICATOR) is illuminated and Q14 is switched ON. Q14 simultaneously makes a SEND line to ground level, putting the transceiver in transmit mode.

4-3 PLL CIRCUITS

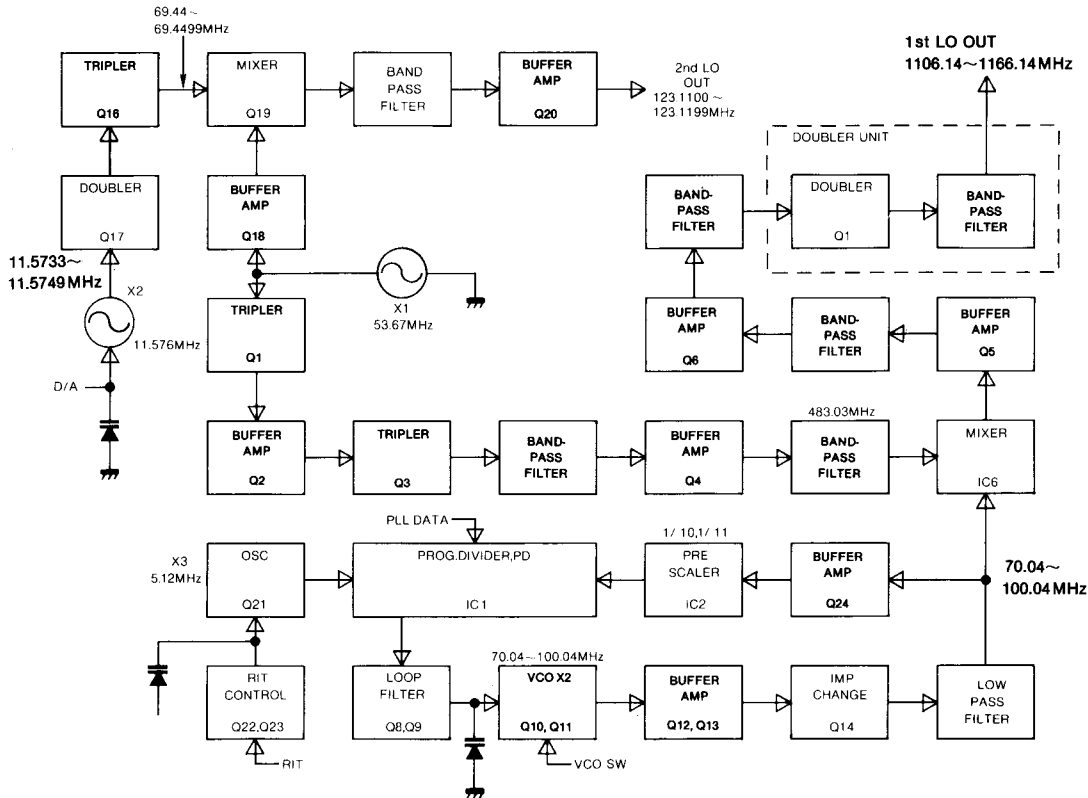

4-3-1 LOCAL OSCILLATORS (PLL UNIT)

This unit has two local oscillators whose roles are:
2nd LO to vary the frequency of the digits from 100Hz to 9.9kHz and simultaneously carry out D/A conversion
1st LO to control digits from 10kHz to 10MHz at the MIX-type PLL.

These two oscillators perform important functions in the IC-1271A/E.

a) REFERENCE OSCILLATOR AND 1ST LO CIRCUITS (PLL UNIT)

X3 (5.12MHz) is oscillated by a Colpitts Oscillator Circuit (Q21) to generate a reference frequency of the PLL IC (IC1). In order to obtain an RIT frequency, the RIT voltage from the EF UNIT is applied to the cathode side of varactor diode D16, and the RIT frequency is controlled using the capacity changes over voltage. Q22 and Q23 are controlled so that there are no RIT changes when RIT is OFF while they are transmitting.

b) 2ND LO CIRCUIT (PLL UNIT)

X2 (11.576MHz) is oscillated by oscillator Q17 to obtain twice the frequency. At the multi-tuning circuit of L29 and L30, the fundamental wave and a high frequency of 3 times the frequency is attenuated. Then, a frequency stepped up a further 3 times at step-up circuit Q16 has excessive splice removed at the multi-tuning circuit of L27 and L28, and is input as the LO signal of FET mixer Q18. A 69.44~69.4499 frequency 6 times that of X2 can then be obtained via the mixer input of Q19. Further, in order to vary the frequency up to 9.9kHz, data DA1-DD1 from the LOGIC UNIT is received by IC4 and IC5 from J4 to obtain the D/A signals. These are removed by the OP amplifier of IC3 and output from pin 1 is added to cathode D14. The capacity of X2 is changed to a voltage over capacity ratio and the frequency is varied. On the other hand, in order to obtain the 2ND LO frequency (123.1100~123.1199MHz), a signal of 53.67MHz from the 1ST LO (local oscillator) is amplified to the required level by Q18 via C147, and is applied as the RF signal of Q19.

Q19 is used as the mixer by the dual-gate FET.

As various frequency components of the signals applied to the respective gates are output to the drain, only the absolutely necessary parts of these frequency components are obtained by the multi-tuning circuit L34 and L35.

Namely, 123.1100~123.1199MHz are obtained. They are further amplified by Q20 so that they can be sufficiently supplied to the IF UNIT where they have their splice removed by multi-tuning circuit L36 and L37, and by LPF L38, L39, C165 through C169.

4-3-2 VCO CIRCUIT (PLL UNIT)

As this is mixed with Crystal LO (X1 stepped-up), and is supplied as the RF MIX input, stringent conditions such as stability, high C/N, spurious radiation, etc., are applied to the VCO itself. ICOM therefore uses temperature-compensated semiconductors with little noise in the circuits themselves.

First, as there is a need to cover the 30MHz waveband, the waveband is divided into four separate bands internally at the VCO to obtain the required signals. Q10 is used for oscillation of 1240~1255MHz and 1255~1270MHz bands, and Q11 is used for oscillation of 1270~1285MHz and 1285~1300MHz bands.

These are mixed by Crystal LO, and the VCO itself oscillates 70.04~100.04MHz which passes signals through buffer amplifier Q12 and isolation amplifier Q13, supplying a low-impedance DBM. Impedance conversion is carried out by Q14 and this becomes the DBM input.

Further, as the DBM comprising IC6 is a passive type, the levels of the LO and RF signals applied to the DBM are high to a certain extent.

There is a need to prevent spurious radiation which may be generated for this purpose (to the high level of the LO and RF signals).

Accordingly, with the intention of removing spurious radiation from the VCO as much as possible, lowpass filters L41~L43, C187~C193, and L44 and C205 have been installed for input.

4-3-3 PRESCALER AND PLL IC CIRCUITS (PLL UNIT)

A portion of the signals from the low-pass filter is amplified by Q42 to the required level for prescaler (IC2) input level via C204.

IC2 contains two modular prescalers. The prescaler frequency divider, controlled by PSC signals from IC1 divides its input frequency by a factor of 10 or 11.

IC1 is a PLL IC which contains a frequency comparator, a programmable divider, a swallow counter and a phase detector.

The reference frequency input to IC1 (pin 12) is converted by the N data (14008 to 20007) from the LOGIC UNIT into the reference frequency needed by the IC's internal frequency comparator. Also, the frequency (70.04~100.04MHz) input to IC2 (pin 4) is divided by IC1's programmable divider and swallow counter and by IC2's prescaler. The two signals are then com-

pared by IC1's internal phase detector and the difference is output from IC1 (pin 1) as the PD signal.

IC1 also includes a lock/unlock function. When unlocked, a HIGH signal is output from IC1 (pin 8), and Q15 switches ON. This is used to control the MUTE signal output.

4-3-4 LOOP FILTER CIRCUIT (PLL UNIT)

The PD voltage (control voltage) output from IC1 (pin 1) is a pulse signal corresponding to a type of phase difference.

Therefore, as there is the need to divide this into DC and at the same time remove the reference leakage and the noise component, an active-type filter Q8 and Q9 is utilized. Also, this loop filter is a circuit fulfilling the important role of determining lock up and down-time. D2 and D3 can speed up lock up and down-time by not passing the signal through R32 when the wideband edge is locked. They are installed with mutually reversed polarities so that they can respond to plus and minus PD pulses.

This DC voltage is applied to the cathode side of varactors D4 or D8, and is controlled so that the lock is continuously stable.

4-3-5 CRYSTAL LO AND MIX AMPLIFIERS (PLL UNIT)

First of all, X1 (53.67MHz) is stepped up three times by Q1, is then amplified by Q2, and is further stepped up by three at Q3. At this time, removal of spurious radiation generated after stepping up and level amplification are carried out by Q4 and the synchronizing circuits.

The signal obtained after removal of the unrequired parts is input as a LO signal of the DBM comprised of IC6. In order to maintain the necessary components and level for the DOUBLER UNIT, amplifiers Q5 and Q6 and helical filters FI4 and FI5 are installed to enable supply at the output side of the DBM.

4-3-6 DOUBLER CIRCUIT (DOUBLER UNIT)

This unit comprises the 1_{ST} LO in combination with the PLL UNIT.

Signals that pass through FI5 on the PLL UNIT are input to the base of Q1 via isolators C4 and L1.

Q1 is a transistor with a gain-bandwidth product (f_T) of 8000MHz which has a gain of 10~12dB when used at a frequency of approximately 1GHz.

In order to improve the multiplication efficiency, Q1 is operated as a C-class operation amplifier to amplify the input signal which is passed through a filter consisting of C5, L2, C6 and L3. As a result, an output signal of twice the frequency of the input signal is obtained. This output signal is sent via C9 to the RF MIX UNIT as the local oscillator signal.

4-4 LOGIC CIRCUITS

The LOGIC UNIT includes an 8-bit N-MOS CPU (μ PD7801G-114), a C-MOS 40-pin DIP malfunction, a custom IC (RP5G01007) and a C-MOS RAM.

The main functions of the LOGIC UNIT are frequency control, mode signal processing, data output to the DISPLAY UNIT and data output to the PLL UNIT.

4-4-1 CPU (LOGIC UNIT)

The terminal functions are as designated in the diagram on the following page. The LOGIC UNIT allocates all addresses for the internal ROM, external RAM and also any peripheral devices.

As the interrupt terminal is allocated for the TUNING CONTROL and the REMOTE CONTROL, the terminal is designed so that the TUNING CONTROL and the REMOTE CONTROL are given priority when in operation.

CPU Port Allocations

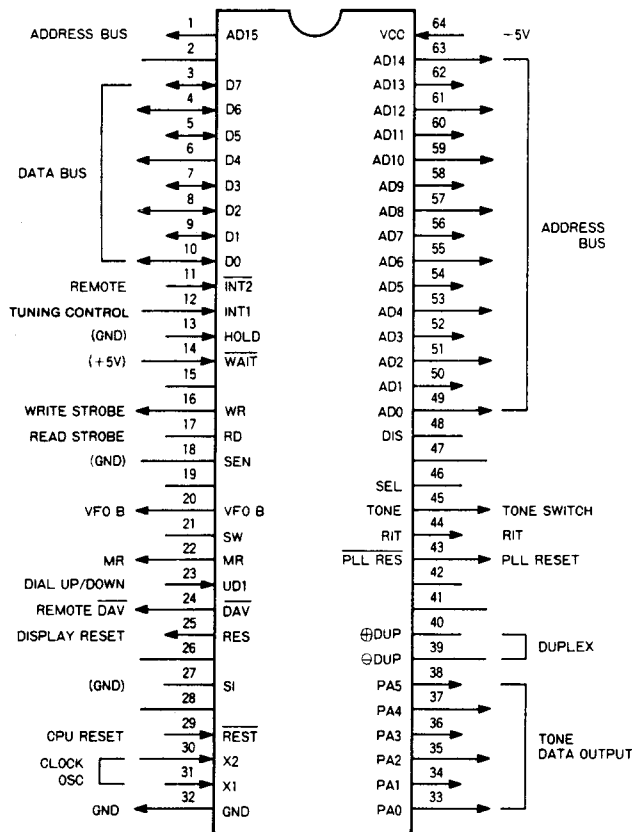

CPU Memory Map

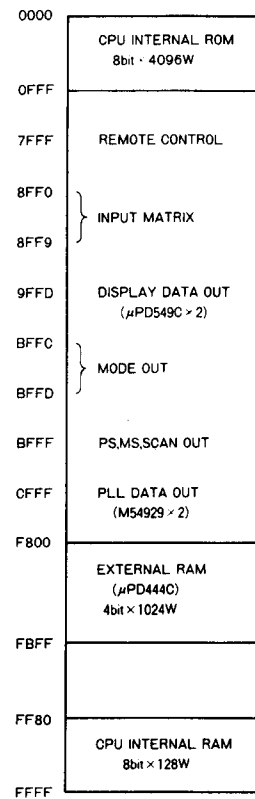

4-4-2 CPU INPUT CONTROL CIRCUIT

a) MULTIFUNCTION, CUSTOM IC

The terminal functions of the custom IC are as designated below.

Input/Output Control IC Port Allocations

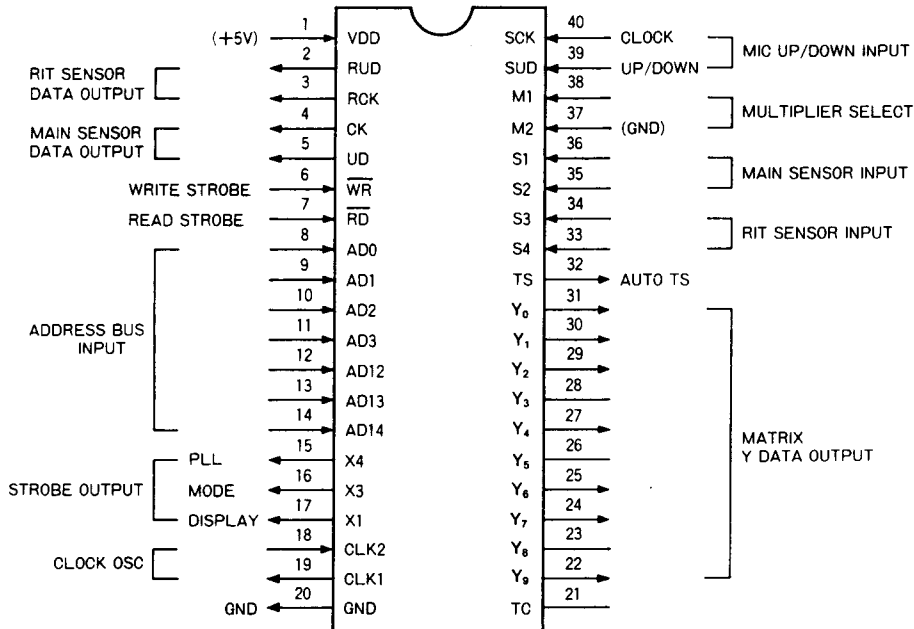

Approximately 50kHz square waves produced by the astable multivibrator, consisting of R34 through R37, C22 and two TTL gates in IC18, are input to the CLOCK terminals (pins 18 and 19) of IC7 (RP5G01007) on the LOGIC UNIT.

The M1 and M2 (GND) terminals (pins 37, 38) are for switching the main sensor's input pulse speed multiplier between 1 and 4. When M1 is HIGH, the multiplier is 1; when M1 is LOW, the multiplier is 4. This circuit uses a 50-pulse main sensor. Ordinarily, M1 becomes HIGH which sets the speed multiplier to 1 as it is ordinarily pulled up by R60.

As shown in table 1, the multiplier of the sensor's input pulse speed is 4 when M1 is LOW.

When a VFO is being used, terminal MR becomes LOW. As MR is LOW when S19 (DFS) is OFF, the collector (Q2) on the FRONT UNIT becomes high-impedance, and a voltage of 5V is applied to R36. Also, the collector becomes high-impedance at the base of Q13 as the MR level is LOW, and a voltage of 5V is applied by the pulled-up resistor R60 on the LOGIC UNIT and is applied to M1.

As a voltage is applied to R37 when S17 (TS) is OFF, the voltage of Q13 is the same. Even when S17 is switched ON, an impedance is applied to R37, and Q13 becomes 5V as the voltage does not change. M1 becomes HIGH and its multiplier is 1 as collector Q13 is connected to terminal M1.

The voltage from R36 is applied to the base of Q13 when S19 is ON, and the collector becomes low-impedance. The voltage applied by R60 becomes 0V and is output to M1. Further, even when S17 is switched ON, the signal is switched to LOW as it is turned to 0V by Q13 after it has passed through R37. If the signal is OFF, voltage is not applied to R37. Therefore, a voltage of 0V is output regardless of M1 and the multiplier becomes 4 as M1 is switched to LOW.

When memory is being used, terminal MR becomes HIGH, and Q12 becomes low-impedance.

If S19 is OFF, voltage is applied to the base of Q13, and as the collector side becomes low-impedance, the voltage applied by R60 becomes 0V, and is output to M1. At this point, even if S17 is switched ON or OFF, the voltage of M1 will be a constant 0V, and M1 will be switched to LOW. Accordingly, the multiplier becomes 4.

When S19 is switched ON, the collector becomes low-impedance as the base of Q13 and is LOW; the collector voltage becomes 5V and M1 becomes HIGH. Therefore, the multiplier is 1. Even when S17 is switched ON and OFF, the signal is 5V as collector Q13 is high-impedance. Therefore, the multiplier remains 1.

VFO				MEMORY			
DFS SW	TS SW	M1	Speed multiplier	DFS SW	TS SW	M1	Speed multiplier
OFF	OFF	HIGH	1 ×	OFF	OFF	LOW	4 ×
OFF	ON	HIGH	1 ×	OFF	ON	LOW	4 ×
ON	OFF	LOW	4 ×	ON	OFF	HIGH	1 ×
ON	ON	LOW	4 ×	ON	ON	HIGH	1 ×

Note: This table is valid regardless of modes.

Table 1

b) MODE SELECT AND FREQUENCY STEP RATE SELECT CIRCUIT

The modes available are FM, USB, LSB, and CW. The step rates available are FM 25kHz when TS is OFF, and 100Hz SSB (USB, LSB) and CW. The step rates for FM, SSB and CW all 1kHz when TS is ON.

The $Y_7 \rightarrow D_4, D_5$ and D_7 matrix determines the frequency steps during sensor operation and scanning. The components involved are IC5, IC6, D18, D21, and D34. In the FM mode, voltage is applied to IC6 (pin 13) from IC9 (pin 10). IC6 (12 pin) is connected to S17 (TS) at the front panel, and when TS is OFF, signal Y_7 is obtained and sent to pin 12, causing signal Y_7 and the FM mode signal (voltage) to enter the AND gate. The Y_7 signal output from IC6 (pin 11) is input to IC8's (CPU) databus (D_6, D_7) via D21 and D34, and the step rate is set for 25kHz. If the TS SWITCH is ON, D18 on the EF UNIT receives a signal from the $Y_7 \rightarrow D_4$ matrix, and the step rate is set to 1kHz regardless of the mode.

The components involved in determining the step rates for SSB and CW are the IC18 inverter gate, a 3-input AND gate, and D18 and D19. The IC18 inverter judges whether the mode is FM or SSB/CW and becomes HIGH if the mode is SSB or CW.

IC18 (pin 2) is input to IC59, and is also input to IC5 via D27. Signal Y_7 is input to IC5 (pin 10) and the respective signals are latched by the AND gate and are output from IC5 (pin 8). The signal output from pin 8 is applied to D_5 ($Y_7 \rightarrow D_5$) via D18, and a step rate of 100Hz is enabled.

	DATA BUS			Step rate (Hz)
	D_4	D_5	D_7	
Y7	1	0	0	1k
	0	1	0	100k
	0	0	1	25k

4-4-3 MATRIX CIRCUIT

The matrices used in this transceiver are as shown below.

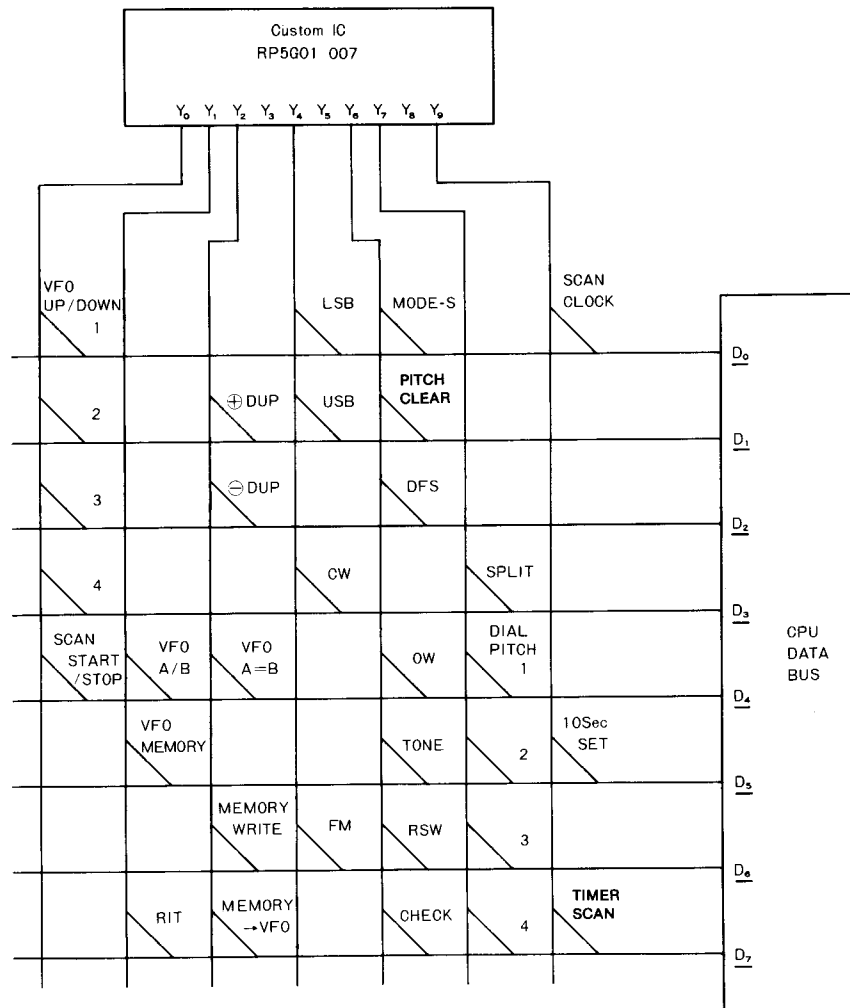

* The D for the data bus is underlined () to differentiate it from D for diode or other components. (e.g., D₀ - D₇)

Y₀ → D₀ (1 MHz UP)
 → D₂ Shifts the frequency 1 MHz upward.
 → D₃

Y₀ → D₁ (1 MHz DOWN)
 → D₂ Shifts the frequency 1 MHz downward.
 → D₃

Y₀ → D₄ (SCAN START/STOP)
 Stops and starts the scan function.

Y₁ → D₄ (VFO A/B)
 Selects VFO A or VFO B; CPU (pin 20) is HIGH when VFO B is selected.

Y₁ → D₅ (VFO/MEMORY)
 Selects the VFO or memory channel function, CPU (pin 22) is HIGH during memory reading.

Y₁ → D₇ (RIT)
 Selects the RIT function; CPU (pin 44) is HIGH when RIT is selected.

Y₂ → D₁ (+ DUP)
 Selects the + DUP function; CPU (pin 40) is HIGH when + DUP is selected.

Y₂ → D₂ (- DUP)
 Selects the - DUP function; CPU (pin 39) is HIGH when - DUP is selected.

Y₂ → D₄ (A=B)
 Equalizes the frequencies stored in VFO A and VFO B.

Y₂ → D₆ (MEMORY WRITE)
 Transfers the displayed frequency and mode to a memory channel.

Y₂ → D₇ (MEMORY VFO)
 Transfers the frequency and mode stored in a memory channel to a VFO.

Y₄ → D₀ (LSB)
 Selects the LSB mode; IC9 (pin 7) on the LOGIC UNIT is HIGH when USB is selected.

Y₄ → D₁ (USB)
 Selects the USB mode; IC9 (pin 8) on the LOGIC UNIT is HIGH when LSB is selected.

$Y_4 \rightarrow D_3$ (CW)
 Selects the CW mode; IC9 (pin 9) on the LOGIC UNIT is HIGH when CW is selected.

$Y_4 \rightarrow D_6$ (FM)
 Selects the FM mode; IC9 (pin 10) on the LOGIC UNIT is HIGH when FM is selected.

$Y_6 \rightarrow D_0$ (MODE SEARCH)
 Selects the mode search function.

$Y_6 \rightarrow D_1$ (STEP RATE CLEAR)
 Clears the step rates as selected with the TUNING RATE SWITCH.

$Y_6 \rightarrow D_2$ (DIAL FUNCTION SELECT)
 Used for the memory channels when using VFO, and varies the frequencies in the memory during memory reading.

$Y_6 \rightarrow D_4$ (OW)
 Sets the duplex shift width.

$Y_6 \rightarrow D_5$ (TONE)
 Selects the subaudible tone function (#03 only).
 Selects the 1750Hz tone call function (#02 only).
 Selects the optional UT-15 Encoder/CTCSS, Tone unit.

$Y_6 \rightarrow D_6$ (RSW)
 Releases the RIT data during transmission and outputs calculated N data. Also functions as a stop signal while scanning is operating.

$Y_6 \rightarrow D_7$ (CHECK)
 Sets only the LOGIC UNIT to transmit; used for checking the offset amount during duplexing and the frequency shift.

$Y_7 \rightarrow D_3$ (SPLIT)
 Selects split frequency operation for transmit/receive using VFO A and VFO B. (RA-TB, RB-TA)

$Y_7 \rightarrow D_4$ (DIAL STEP RATE 1kHz)
 Selects a 1kHz tuning rate.

$Y_7 \rightarrow D_5$ (DIAL STEP RATE 100Hz)
 Selects a 100Hz tuning rate.

$Y_7 \rightarrow D_7$ (DIAL STEP RATE 25kHz)
 Selects a 25kHz tuning rate.

$Y_7 \rightarrow D_6$ (DIAL STEP RATE 1MHz)
 D_7 Selects a 1MHz tuning rate.

$Y_9 \rightarrow D_0$ (SCAN CLOCK)
 Inputs a clock signal when scanning.

$Y_9 \rightarrow D_5$ (10 SEC SET)
 Timer function for the scan stop periods.

$Y_9 \rightarrow D_7$ (TIMER ON/OFF)
 Switches the Y_6-D_5 timer ON and OFF.

4-4-4 DISPLAY AND PLL STROBE CIRCUITS

Output from IC7 (pin 17) (the X_1 signal), and IC7 (pin 15) (the X_4 signal) on the LOGIC UNIT is combined with PLL and display strobe signals by an AND gate in IC5. These signals are then input to IC20 (pin 6).

IC20 contains a monostable multivibrator which increases the pulse width of the input signal and passes the output from IC20 (pins 5 and 12) to IC6 (pin 1) and IC3 (pin 6).

The output from IC8 (pin 43), $\overline{\text{PLL RES}}$, is input to the inverter IC18 (pin 3). The output from pin 4 passes to AND gates in IC1 and IC2. When the PLL strobe signal is input to IC6 (pin 1), pin 2 of IC6 becomes HIGH. IC6 (pin 2) becomes LOW when the DISPLAY UNIT strobe signal is LOW. Diode switch D28 turns OFF and then IC3 (pin 5) is pulled down by R54.

The monostable multivibrator consists of two NOR gates (IC3), R9 through R11, C10 and D1. It is triggered by the trailing edge of the signal from IC20 (pin 12). At this time, it outputs the DISPLAY UNIT'S CTL signal. R8 and C9 at IC20 (pins 6 and 7) determine the time constant pulse width.

DISPLAY AND PLL STROBE CIRCUITS

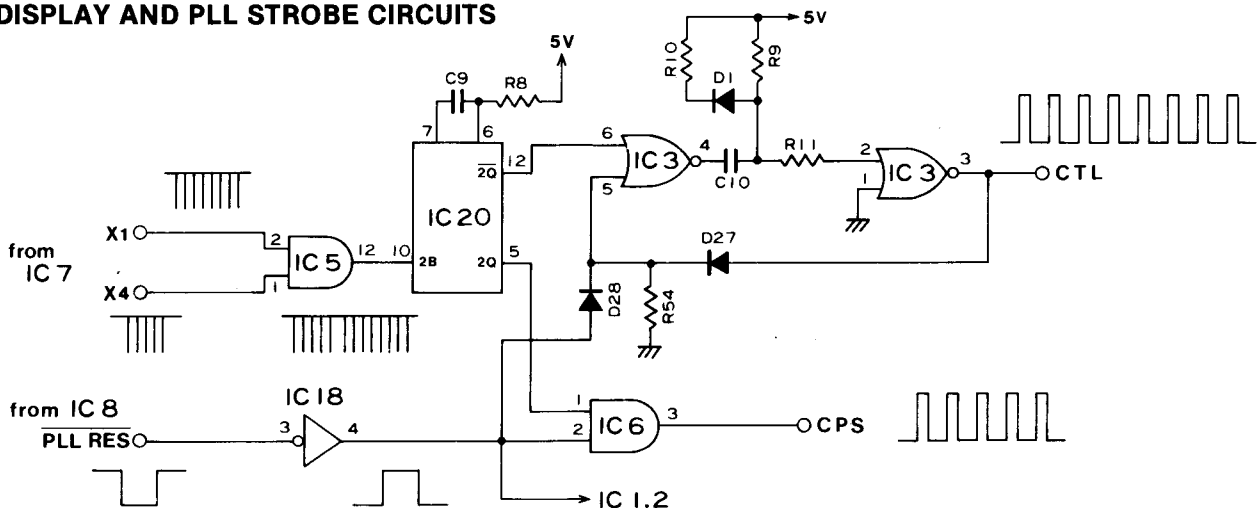

4-4-5 DISPLAY DATA

Eight CTL pulses automatically set the display driver IC (μ PD549C). If there are fewer than eight CTL pulses, the transfer mode is in progress and the display is

masked.

The display data is sent whenever the frequency is changed, the memory channel is changed, or if some other operation affecting the display is carried out.

Display data timing

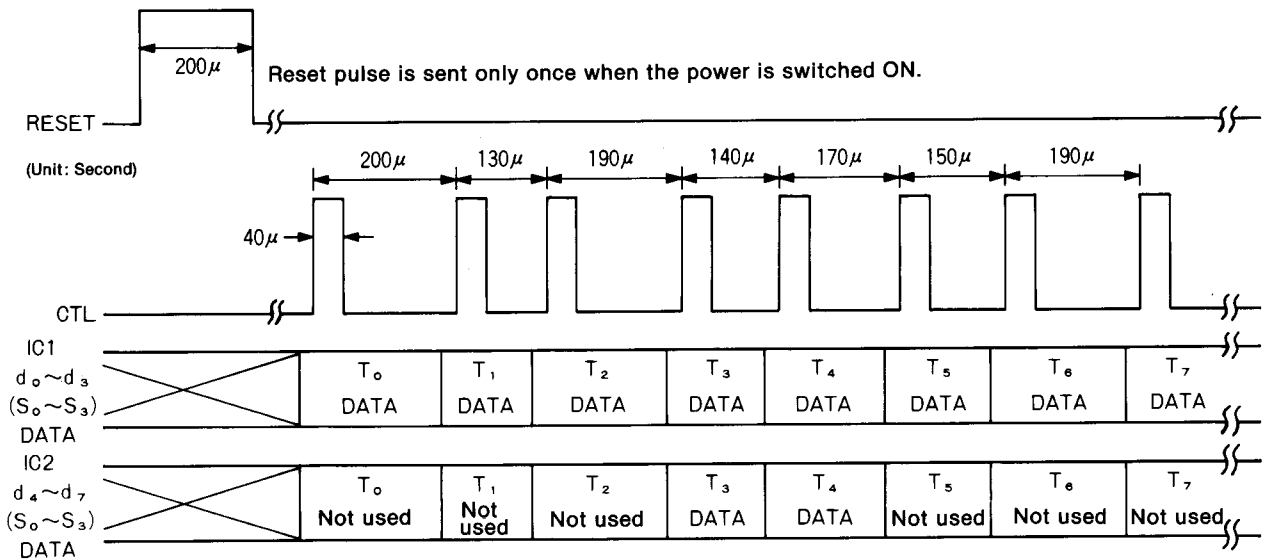

4-4-6 MODE, MEMO, VFO, SCAN, DUP AND RIT DISPLAYS

When one of the mode switches (S22 through S25) or the SCAN SWITCH (S14) on the front panel is switched ON, the mode signal or scan strobe signal is output from IC7 (pin 16) in the LOGIC UNIT to IC20 (pin 2) (1B). It is also output to IC4 (pin 11) (2CK) and IC4 (pin 3) (1CK).

The X_3 signal input to IC20 (pin 2) has its pulse width increased by the monostable multivibrator and by the time constants of R7 and C8 which are connected to the timing terminals (pins 14 and 15). The output from pin 4 passes through the monostable multivibrator which includes IC3's two NOR gates, R29, R30, R31, R47, D7 and C18, and is input to the strobe terminal IC9 (pin 6).

The X_3 signal is input to the clock input terminals, IC4 (pins 3 and 11), by the two D-type flip-flops contained within the IC. In addition, the address data from IC8 (pins 49 and 50) is input to IC9's port select terminals (S_0, S_1). The data (d_0 through d_3) from IC12 (pins 12, 15, 16 and 19) is input to IC9 (pins 2, 3, 27, 28).

IC9 contains four sets of I/O ports which are used as two sets of latches.

IC9 (pin 20) becomes HIGH during program scanning and pin 21 becomes HIGH during memory scanning. Also, pins 10, 9, 8 and 7 become HIGH while the FM, CW, USB or LSB modes are selected, respectively, and these HIGH signals are output as the mode signal.

As the MAIN UNIT requires an 8V mode signal, the mode signal from IC9 is input to IC10 which contains seven open emitters.

IC10 converts the mode signals into 9V FM, CW, USB or LSB mode signals, and then supplies these signals to the DISPLAY UNIT and the MAIN UNIT.

IC9 (pin 20) (PS) and IC9 (pin 21) (MS) make an OR circuit with D8 and D9. When either PS or MS is HIGH, part of the signal is output to the DISPLAY UNIT for the main display and part is input to IC13 (pin 8) for the start of the scanning clock. Next, if the +DUP, -DUP, VFO/M or RIT functions are selected from the front panel (i.e. turned ON), the corresponding terminals of IC8 become HIGH.

When the $Y_1 \rightarrow D_7$ matrix is ON, IC8 (pin 44) (RIT terminal) becomes HIGH. This signal is input to inverter IC11 (pin 11) and output from IC11 (pin 13) as the RIT signal.

This RIT signal is input to the base of Q11 via R12 on the DISPLAY UNIT. A digit signal (T_1) for displaying the characters "RIT" at the display is sent from IC12 to the emitter of Q11.

Q11 comes ON when the RIT signal is sent to Q11, and signal (T_1) is applied to pin 42 of the display to indicate "RIT" on the display.

$Y_2 \rightarrow D_1$ and $Y_2 \rightarrow D_2$ are the +DUP and -DUP matrices. When one of these matrices is ON, IC8 (pin 40 or 39) becomes HIGH. This signal is input to the NOR gate at pin 2 and the inverter in IC11 (pin 6), then is input to the DISPLAY UNIT (Q9 and Q10) as +DUP and -DUP signals, and finally is output to the display.

+DUP signals are also converted to DUP signals by inputting the +DUP and -DUP signals to a NOR gate. In other words, except when IC11 pins 2 and 3 are LOW (no DUP condition), pin 1 is HIGH so +DUP signals are input from R27 on the FRONT UNIT to the base of Q6 via the DISPLAY UNIT.

4-4-9 PLL N DATA

Because the PLL is a two-loop construction, the two-line N data from the LOGIC UNIT is supplied to the PLL system.

The data from the databus IC8 (pins 3~8) uses eight D-type flip-flops contained in IC12 as latches. The display, PLL, mode and scan strobe signals of IC7 (pins 15~17) ($X_1 \sim X_4$) are developed by IC5's three-input AND

gate and input from pin 6 to the clock input terminal at IC12 (pin 11). This latches the sequential data for each strobe.

As d0 through d7 of IC12 are also used by data other than the PLL, IC8 (pin 43) ($\overline{\text{PLL RES}}$) uses the IC18 inverter and the IC1 and IC2 AND gates to open the gate only for the valid time of the PLL data, and the latch data is output from IC12 to the PLL UNIT.

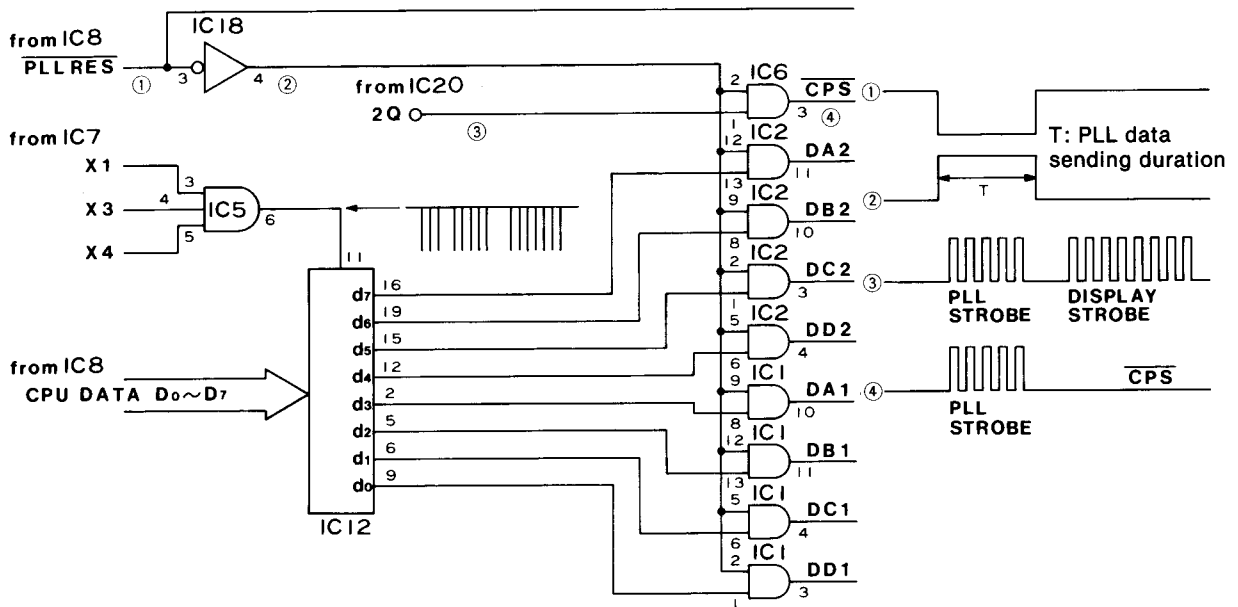

The reset input of IC1 (M54929P) on the PLL UNIT requires a LOW level. Reading is carried out at the trailing edge of the five N data items and the five $\overline{\text{CPS}}$ strobe pulses.

When reset input is HIGH, the $\overline{\text{CPS}}$ strobe pulse is not accepted. Data is read from the least significant digit.

N DATA OUTPUT TIMING

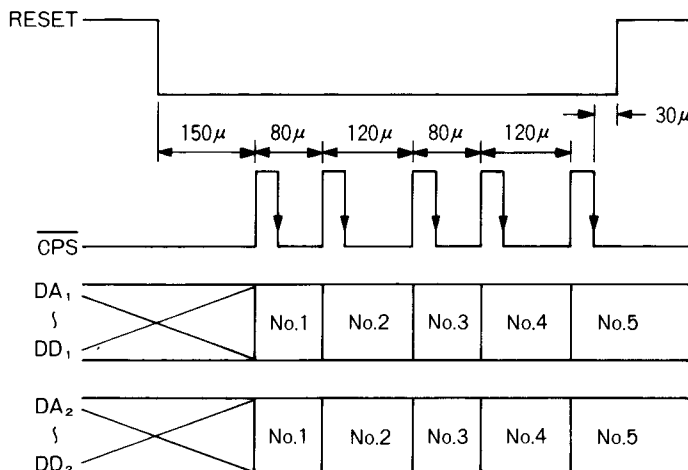

Method for obtaining N data

1,270,000.0MHz

$\text{DA}_2 \sim \text{DD}_2 = 127000 - 109992 \rightarrow 17008$

$\text{DA}_1 \sim \text{DD}_1 = 00000 + 00000 \rightarrow 00000$

1,279,999.9MHz

$\text{DA}_2 \sim \text{DD}_2 = 127999 - 109992 \rightarrow 18007$

$\text{DA}_1 \sim \text{DD}_1 = 99990 - 00000 \rightarrow 99990$

4-4-10 SUBAUDIBLE TONE CIRCUIT (#03)

This transceiver uses IC19 as a tone generator for CTCSS. Pins 5 and 6 of IC19 are input terminals for a 3.579545MHz crystal, data PA0~PA5, and a standby terminal.

Data PA0~PA5 is supplied from IC8 (pins 33~38). IC15, IC16, IC18 and Q1 form a standby switch circuit. When IC18 (pin 11) becomes LOW, the signal is input to IC16 (flip-flop) via a debouncing circuit composed of R45, R41, R3, C3 and IC15, thus forming the ON/OFF SWITCH.

The tone frequency from IC19 is output to the MAIN UNIT. In addition, the data from IC8 (pins 33~38) is used as the Tone Squelch data.

4-5 VCC CIRCUITS

The VCC UNIT comprises two circuits for blanking the RIT frequency display and the VCO selection. The VCO selection divides the 60MHz of 1240~1300MHz into four sections of 15MHz each, and selects them individually.

IC1 is a decimal counter comprising five D-type flip-flops. IC2 incorporates four D-type flip-flops, and is used as a latch in the VCC UNIT.

RES (reset), which becomes HIGH only when the display clock (CTL) power supply is ON at IC1 (pin 14), passes through D5, enters pin 15 of the clear terminal (CL), and display frequency data d0~d3 is input to IC2.

When the 6th (display frequency 10MHz) pulse of the clock input to IC1 (pin 14) has been input, pin 5 (Q6) becomes HIGH, and enters IC2 (pin 9) (CK terminal). At this time, the 10MHz frequency data input to pin 4 (D0 terminal), pin 5 (D1 terminal), pin 12 (D2 terminal), and pin 13 (D3 terminal) of IC2 from the LOGIC UNIT are latched and output to pin 2 (Q0), pin 3 (Q0), pin 6 (Q1), pin 15 (Q3) and pin 14 (Q3), respectively.

Further, SEL voltage (which repeatedly becomes HIGH and LOW every 5MHz) from the LOGIC UNIT is divided by R5 and R6 due to its being 9V, and is converted to approximately 5V, before entering IC5 (pin 5) and IC3 (pin 1).

This frequency data and the SEL voltage are output to each of the OR, AND and NOR gates of IC3, IC4 and IC5 to provide VC1 from IC4 (pin 3), VC2 from IC5 (pin 10), VC3 from pin 3, and VC4 from pin 11.

Since VCO selection voltages are 5V, they are converted to 8V, and are output to the PLL UNIT. IC1 (pin 4) becomes HIGH when the second CTL pulse (RIT frequency 1kHz) is input. It then passes through D1~D4, sends F (HEX) to d4~d7, and blanks the RIT frequency display.

4-6 DISPLAY CIRCUITS

4-6-1 DISPLAY CIRCUIT (DISPLAY UNIT)

This unit utilizes a custom display tube. The display provides a readout of the frequency, mode, RIT, memory channel and operating mode (VFO, SCAN etc.) for indicating operational status.

Frequency indicators are lit by dynamic data output from IC1 (μ PD549C) on the DISPLAY UNIT.

DUP and RIT readouts are displayed dynamically as Q9, Q10 and Q11 are switched by digit signals from IC1 (T4 and T5) and IC2 (T1).

4-6-2 DC-DC CONVERTER CIRCUIT (DISPLAY UNIT)

The DC-DC converter supplies voltages of $\pm 5V$ for IC1 and IC2, and $-35V$ and 3.5V AC for the display.

The +5 volts are supplied from the FRONT UNIT. The DC-DC converter is an inverter composed of Q12, Q13, C4, C5, R16, R17 and T1, and generates a square wave of approximately 15kHz. The voltages of $-5V$, $-35V$ and 3.5V AC are obtained from a separate winding wrapped around T1. With the exception of the 3.5V AC for the display filament, all output is rectified and converted to DC.

For the $-5V$, the output rectified by D14 is stabilized by D13, R18, C7 and C11, and then supplied to the V_{GG} of IC1 and IC2.

The IC-1271 has a function for keeping the display dark for approximately 2 seconds from the time transceiver power is switched ON.

For this, IC8 on the LOGIC UNIT is reset by the integrated pulse from D15, R26 and C17 after power has been turned ON. Approximately 2 seconds after this, data is sent to the PLL and DISPLAY UNITS. The display is kept dark for these 2 seconds. Q14, Q15 and Q16 in the DISPLAY UNIT are circuits used for this. Q14 operates as a switch for cutting the $-35V$. Directly after power is turned ON, $-35V$ are not supplied to the display when Q14, Q15 and Q16 are OFF. After approximately 2 seconds, Q16 comes ON via the CTL signal output from the LOGIC UNIT which turns Q14, Q15 and Q16 ON and supplies $-35V$.

Q15 and C10 form a latch circuit to maintain the output of the $-35V$ once the circuit is switched ON.

DISPLAY CIRCUIT

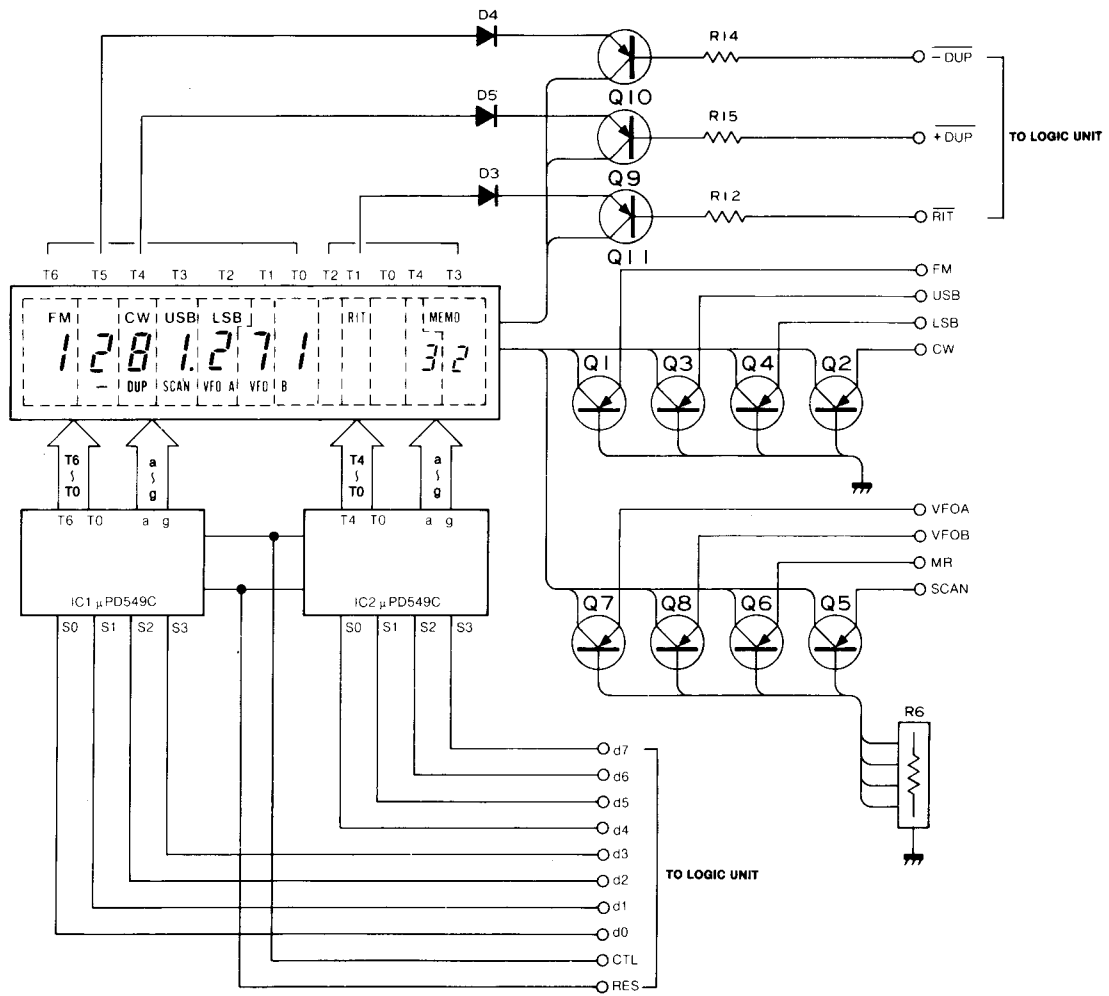

SECTION 5 MECHANICAL PARTS AND DISASSEMBLY

5-1 FRAME DISASSEMBLY

1. Unscrew and remove the 10 screws labelled ① from the top cover. Remove the top cover.
2. Unscrew and remove the 6 screws labelled ② from the bottom cover. Remove the bottom cover.
3. Remove the hex screw labelled ③ from the TUNING CONTROL. Pull off the TUNING CONTROL and the other 7 knobs from the front panel.
4. Unscrew and remove the 5 screws labelled ④ from the front panel. Remove the front panel.

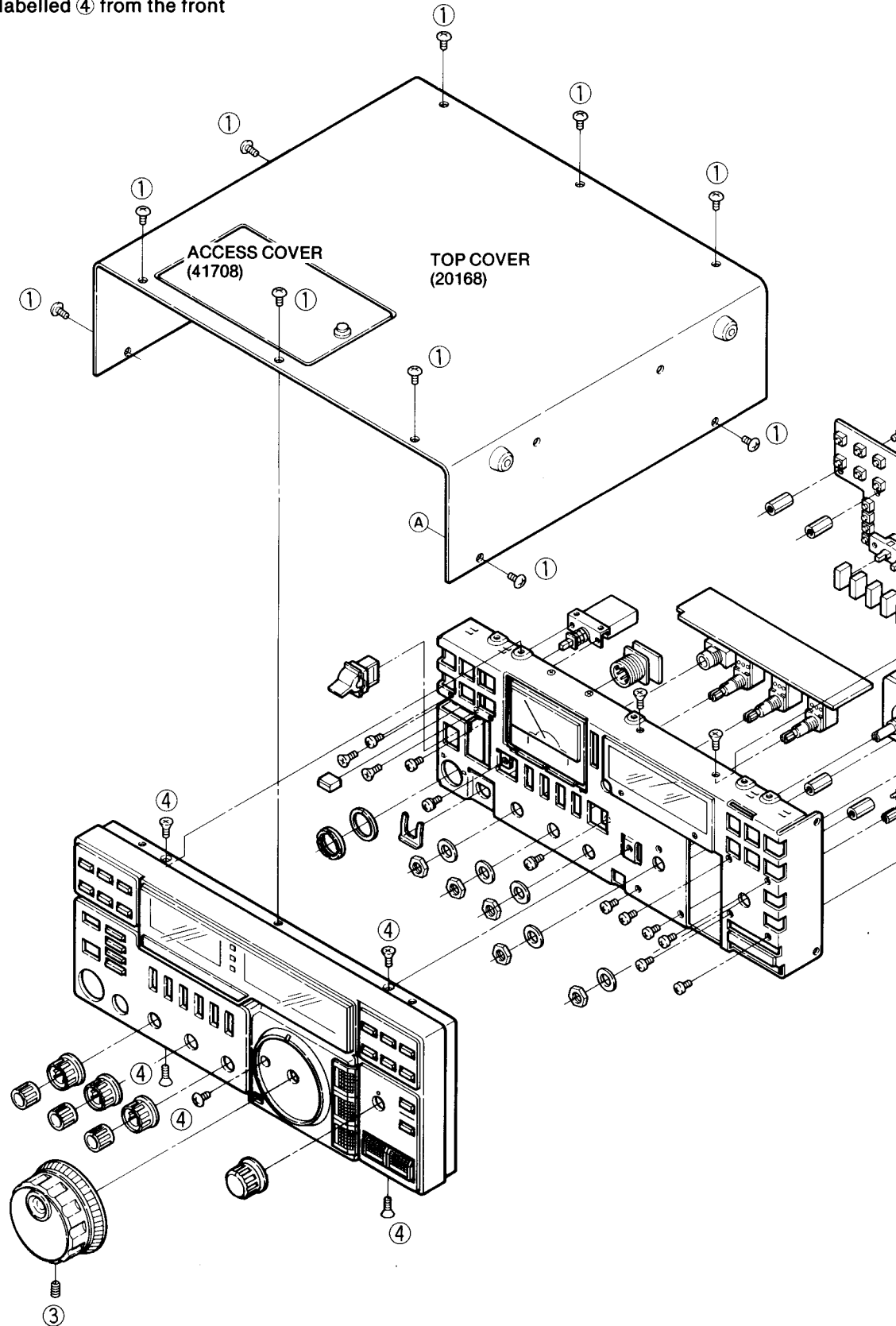

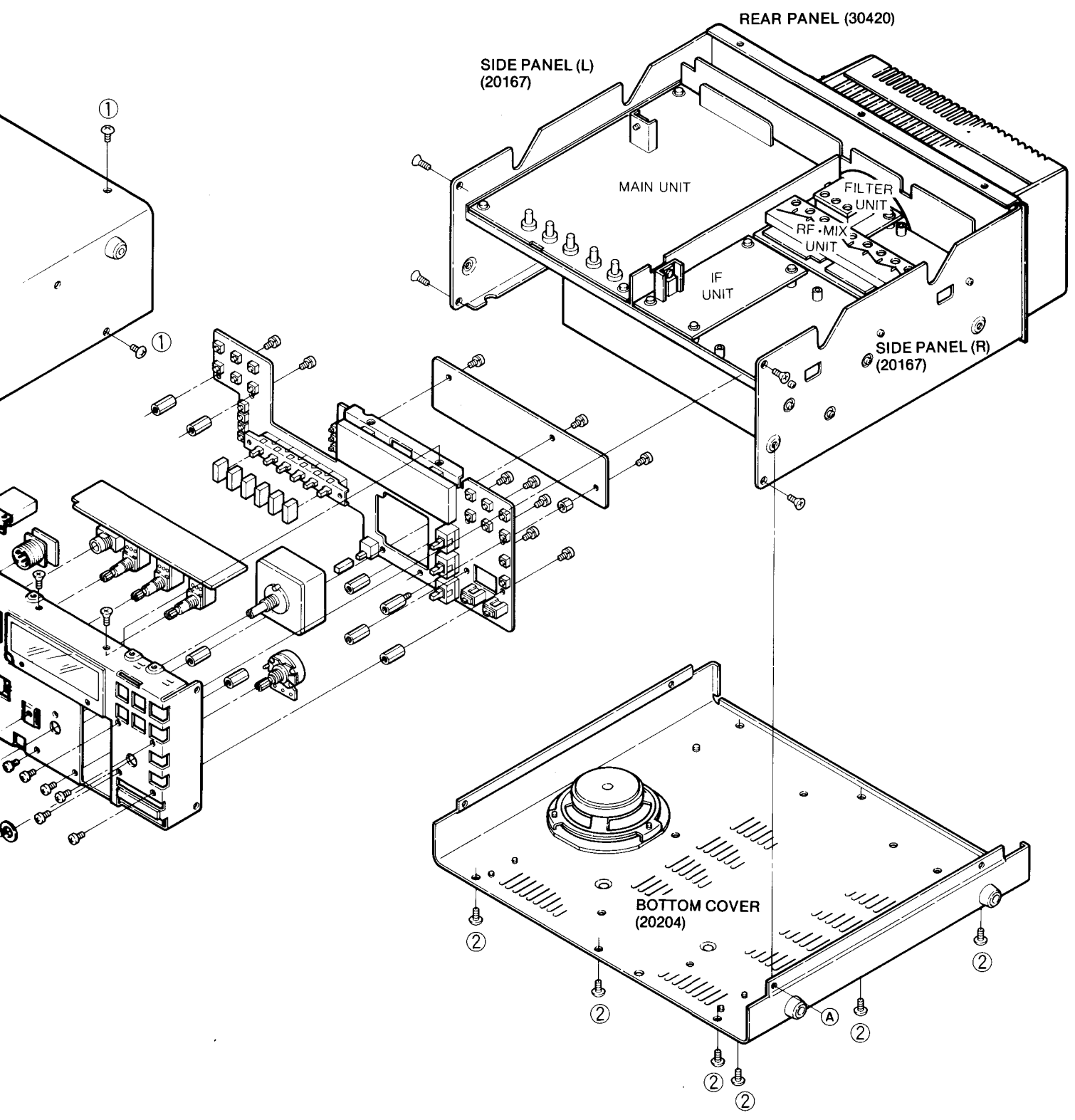

5-2 FRONT PANEL DISASSEMBLY

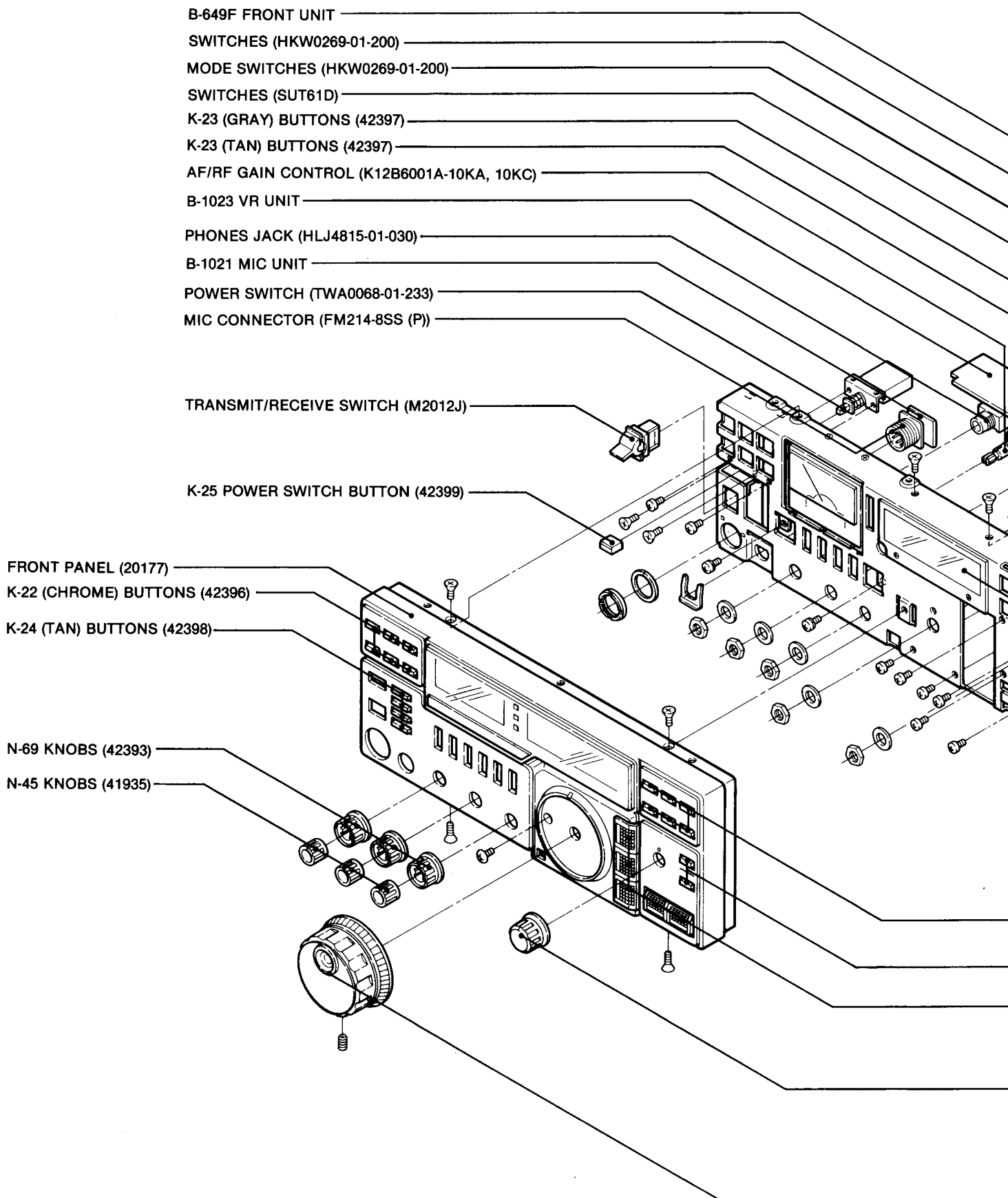

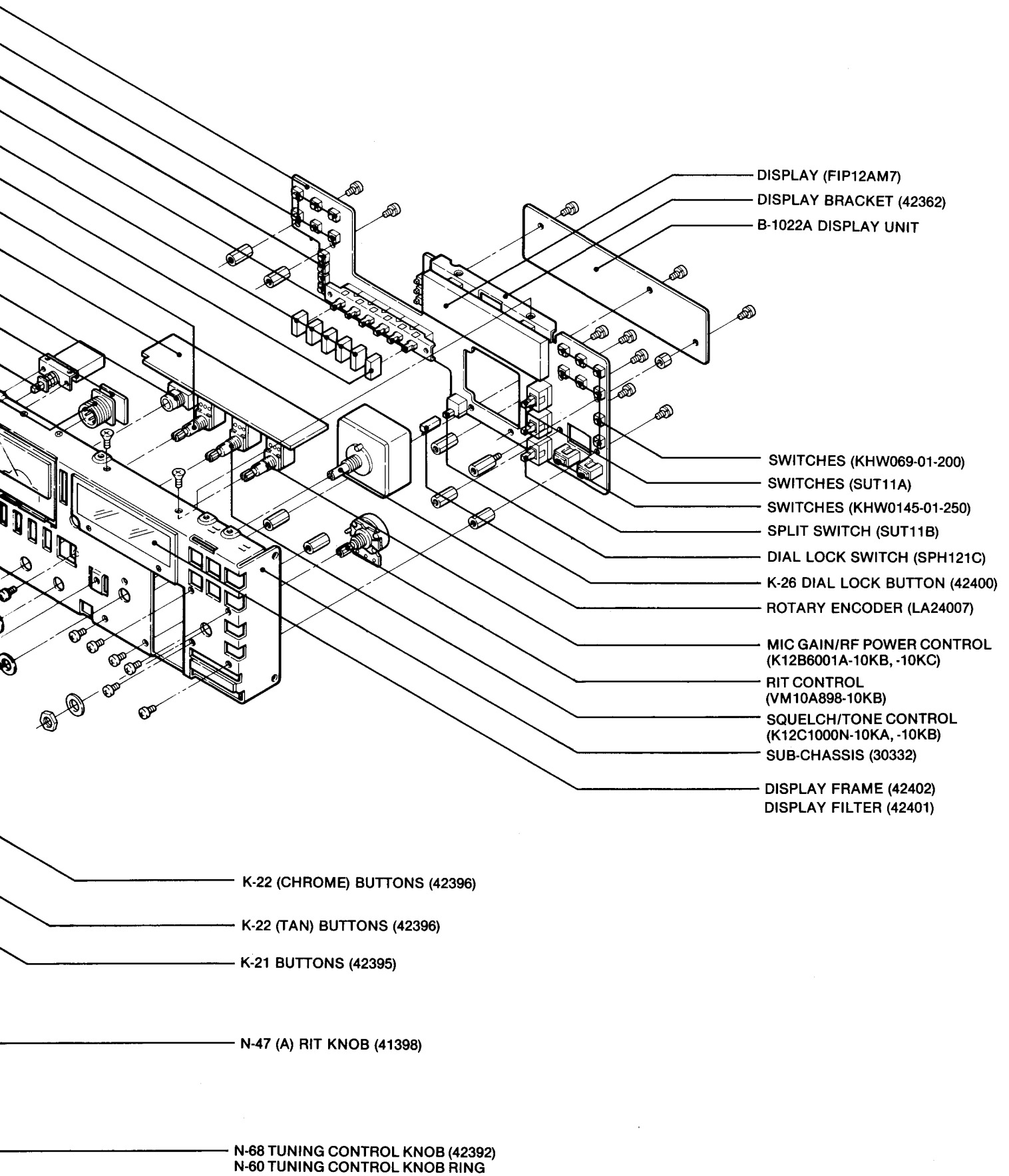

5-3 REAR PANEL PARTS DISASSEMBLY

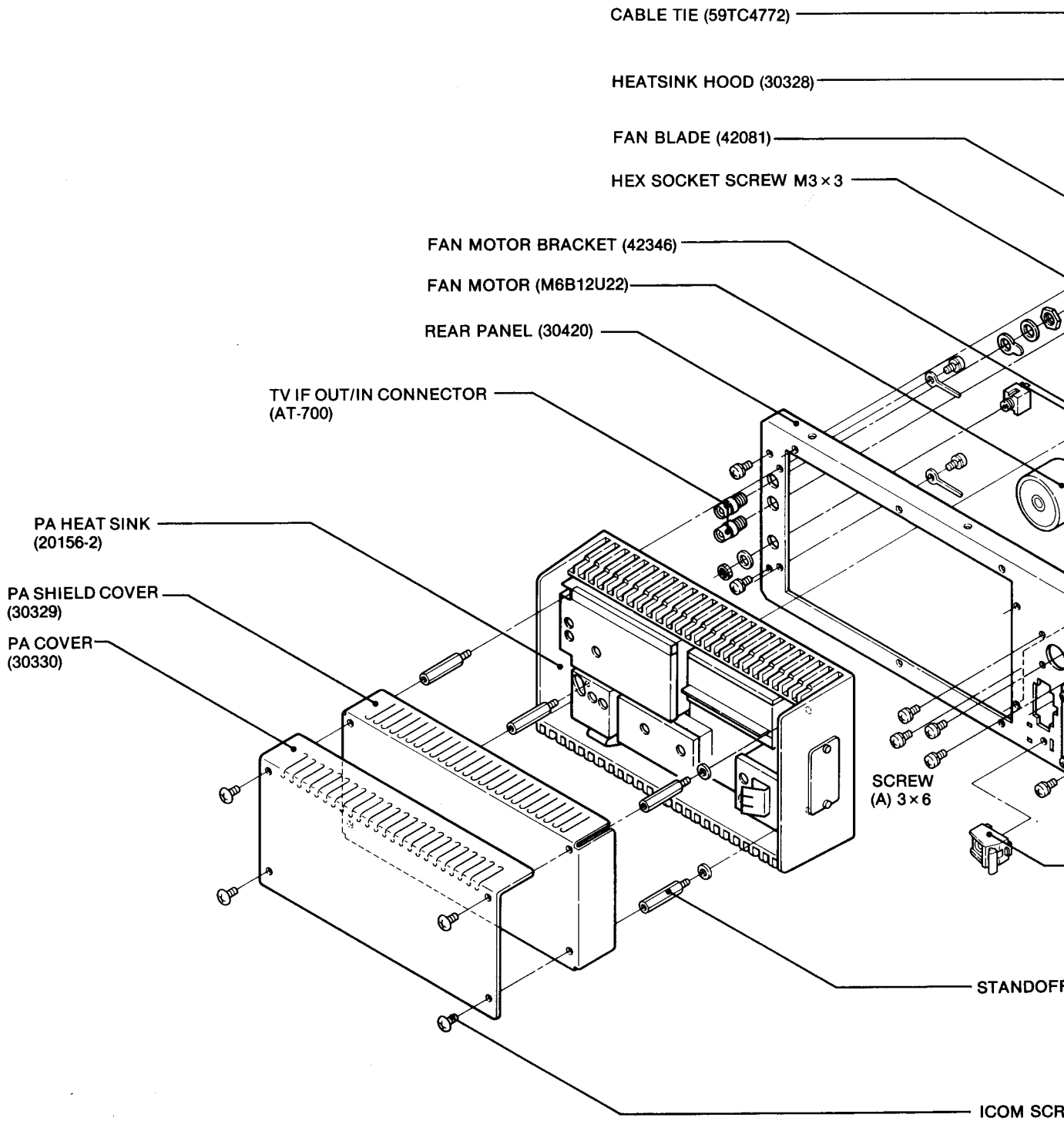

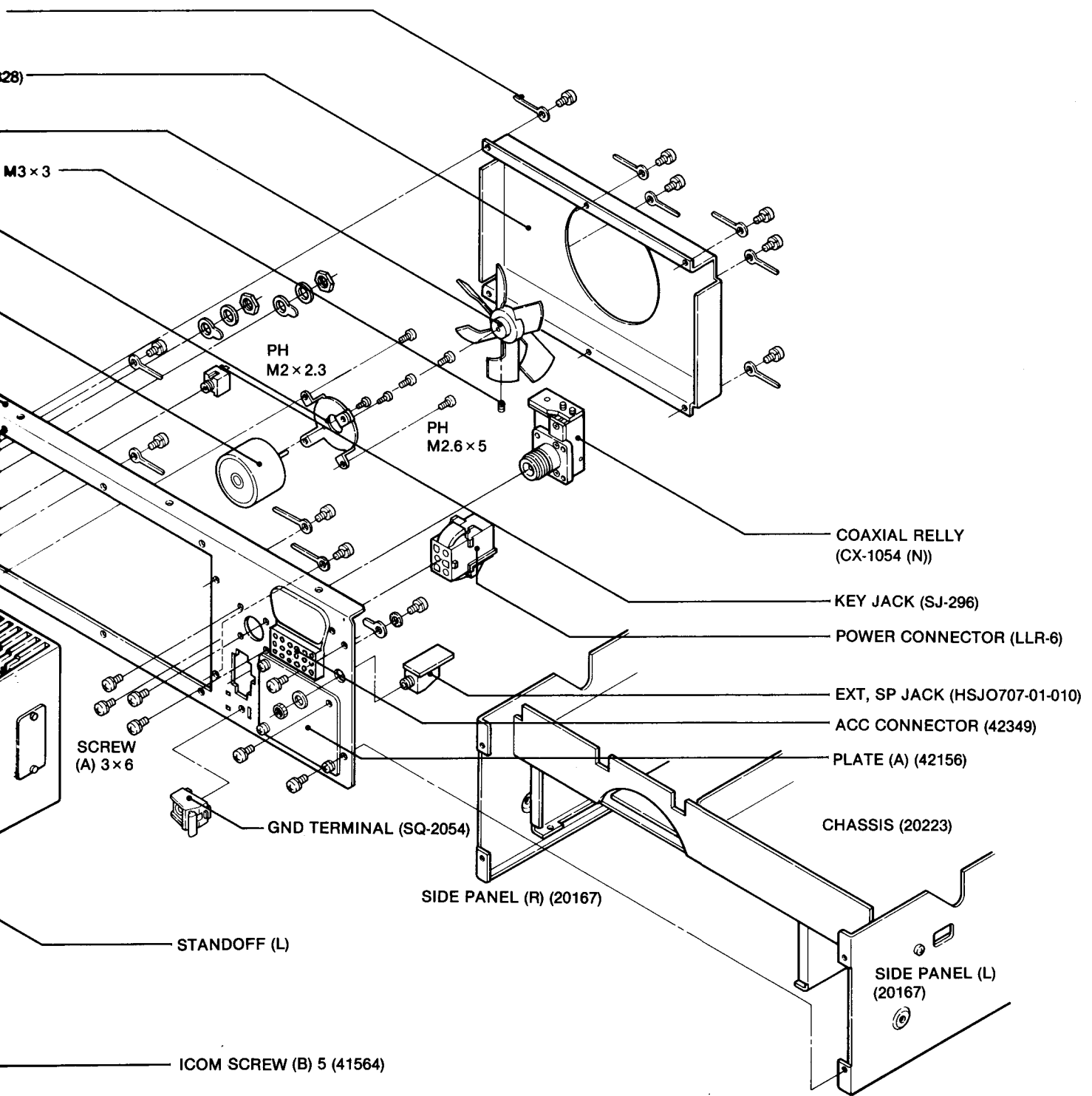

5-4 MAIN UNIT CONNECTOR ASSEMBLY

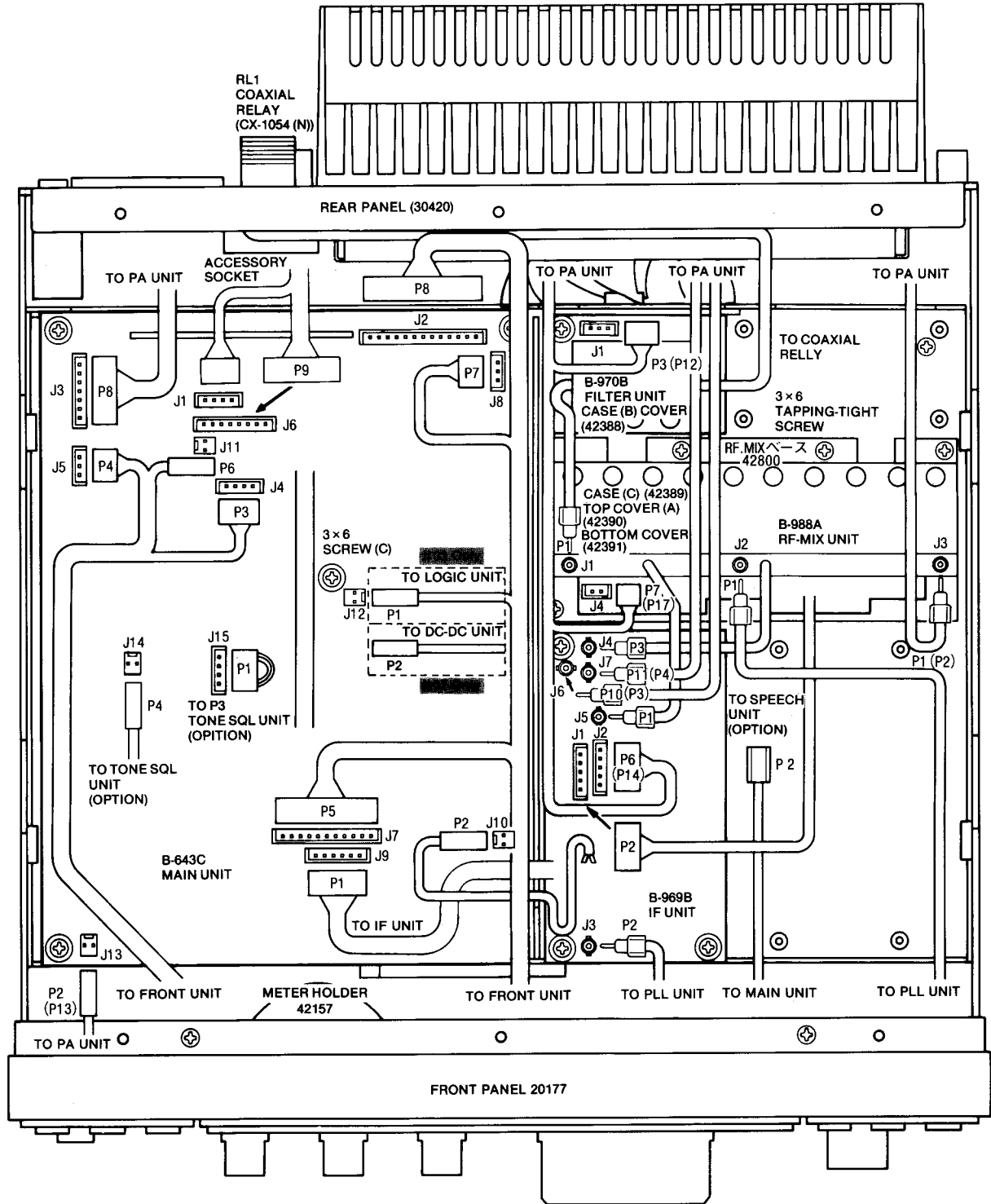

Bracketed pin numbers indicate pins in the PA UNIT (TRANSISTOR-TYPE)

5-5 LOGIC/PLL UNIT ASSEMBLIES

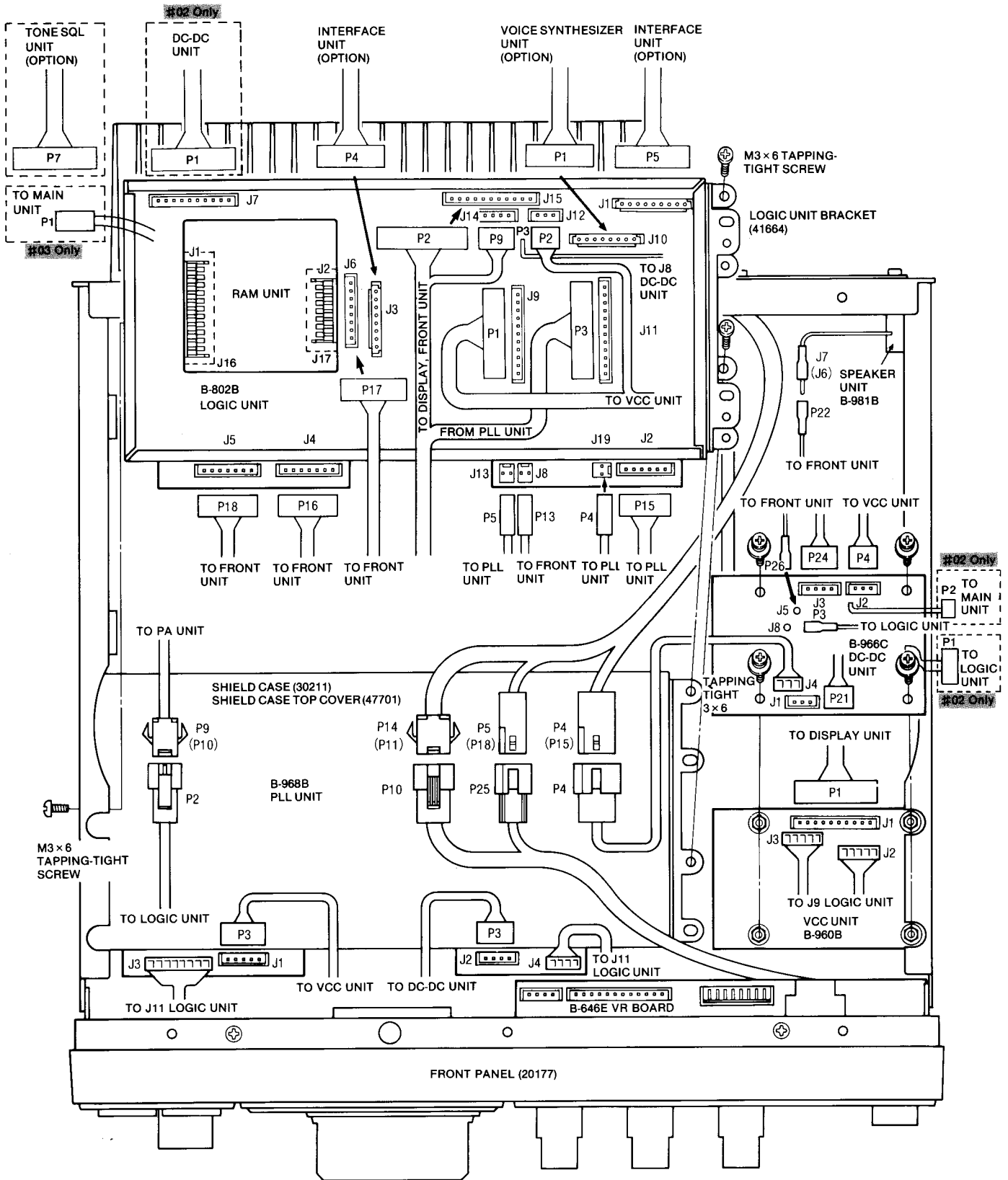

Bracketed pin numbers indicate pins in the PA UNIT (TRANSISTOR-TYPE)

5-6 FRONT SUB-CHASSIS CONNECTOR ASSEMBLY

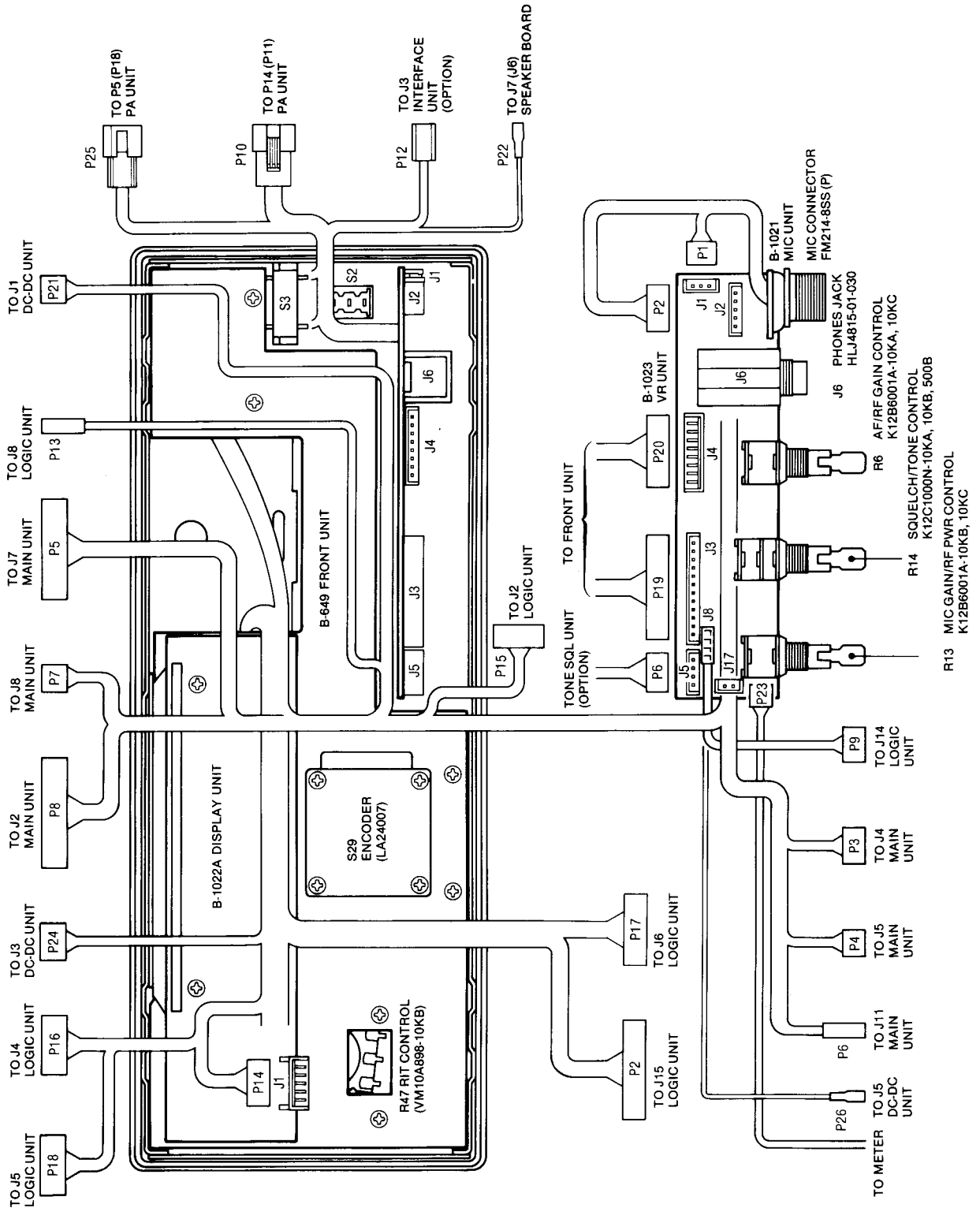

Bracketed pin numbers indicate pins in the PA UNIT (TRANSISTOR-TYPE)

5-7 REAR PANEL CONNECTOR ASSEMBLY

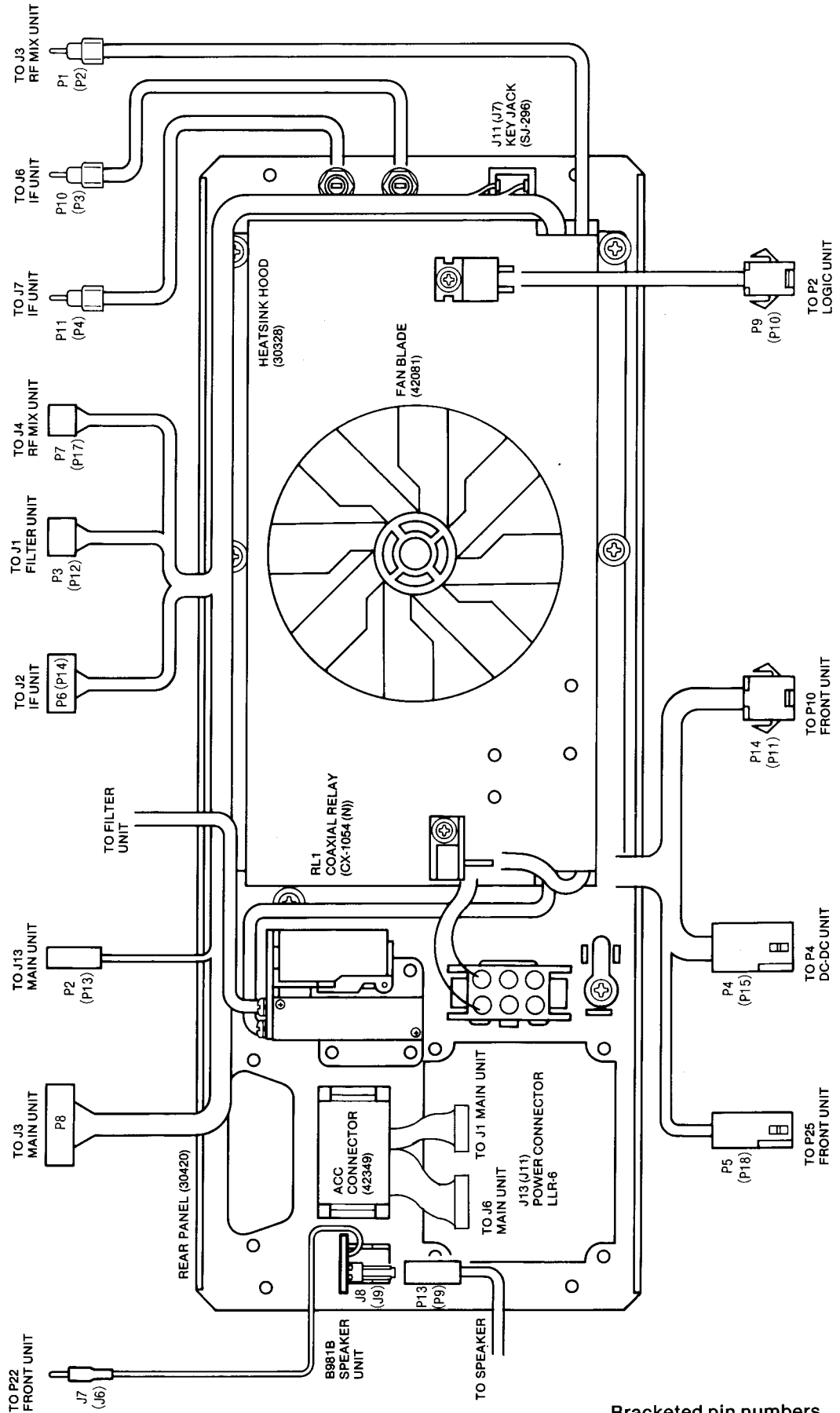

Bracketed pin numbers indicate pins in the PA UNIT (TRANSISTOR-TYPE)

SECTION 6 MAINTENANCE AND ADJUSTMENT

6-1 PREPARATION BEFORE SERVICING

1. Detach the power cord and turn OFF the POWER SWITCH before performing any work on the transceiver.
2. Do not short circuit components while making adjustments.
3. Use an insulated tuning tool for all adjustments.
4. Do not force any of the variable components. Tune them slowly and smoothly.
5. Follow the instructions exactly. If an indicated result is not obtained, repeat the instruction until the correct result is obtained.
6. Check the condition of connectors, solder joints and screws when adjustments are complete. Confirm that components do not touch each other.
7. There are different versions of this transceiver. Adjustment procedures and results may differ for each version. Be certain to follow the correct procedure for the transceiver you have.
8. Confirm defective operation of the transceiver first when checking an out-of-service unit. Verify that external sources do not cause the problem.
9. Use the correct tools and test equipment.
10. Remove the transceiver case as shown in SECTION 5-1.
11. Attach a 13.8 volt DC external power source to the power supply connector. Be sure to check the polarity.
12. For transmission problems, attach a dummy load to the ANTENNA CONNECTOR. For reception problems, attach an antenna or signal generator to the ANTENNA CONNECTOR. Do not transmit into the signal generator.
13. Recheck for the suspected malfunction with the POWER SWITCH ON.
14. Check the defective circuit. Measure the DC voltages of the collector, base and emitter of each transistor.

6-2 PLL ADJUSTMENT

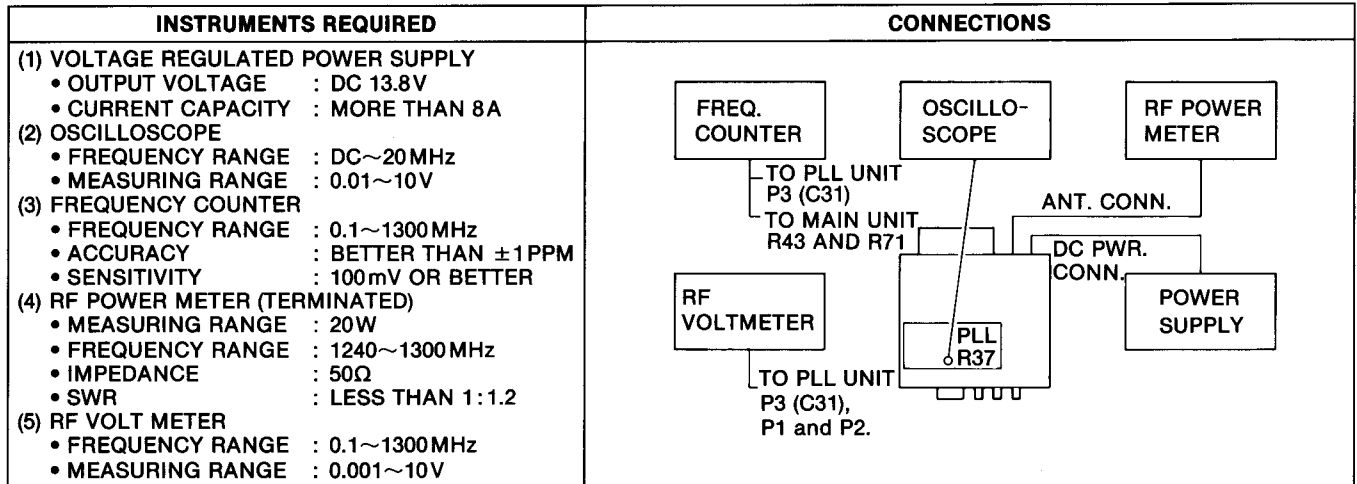

ADJUSTMENT	ADJUSTMENT CONDITIONS	UNIT	MEASUREMENT LOCATION	VALUE	UNIT	ADJUST
PLL LOCK VOLTAGE	1	PLL	Connect an oscilloscope to R37.	0.8V	PLL	C77
	2			6.0V		C91
	3			0.6V~6.0V		Verify
CRYSTAL LO OUTPUT	1	PLL	Connect an RF voltmeter to P3 (C31).	Maximum output: more than 0dBm	PLL	L2~L5, C21, F11, C29, F12
	2		Connect a frequency counter to P3 (C31).	483.0300 MHz		L1
NOTE: After adjusting the frequency, verify the output level (step 1) again.						
2ND LO OUTPUT	1	PLL	Connect an RF voltmeter to P2.	Maximum output: more than -10dBm	PLL	L27~L30, L32, L34~L37
	2		Connect a frequency counter to P2.	123.11000MHz.		R85
	3		123.11990MHz.	R94		
NOTE: R92 is a fine-adjustment resistor for steps 1 and 2.						
DOUBLER OUTPUT	1	DOUBLER	Connect an RF voltmeter to P1.	Maximum output: more than +10dBm	DOUBLER	C5
	2					C6
	3					C4
NOTE: If measured value is not more than +10dBm, readjust (above steps 1 to 3).						
BFO FREQUENCY	a) FM	MAIN	Connect a frequency counter to R43.	10.75000MHz	MAIN	L1
	b) LSB			10.75150MHz		C47
	c) CW-T			10.74930MHz		L8
	d) CW-R			10.74850MHz		L7
	e) USB			10.74850MHz ± 50Hz		Verify
NOTE: After adjustment, set the transceiver to receive mode.						

UNIT LOCATIONS

(BOTTOM VIEW)

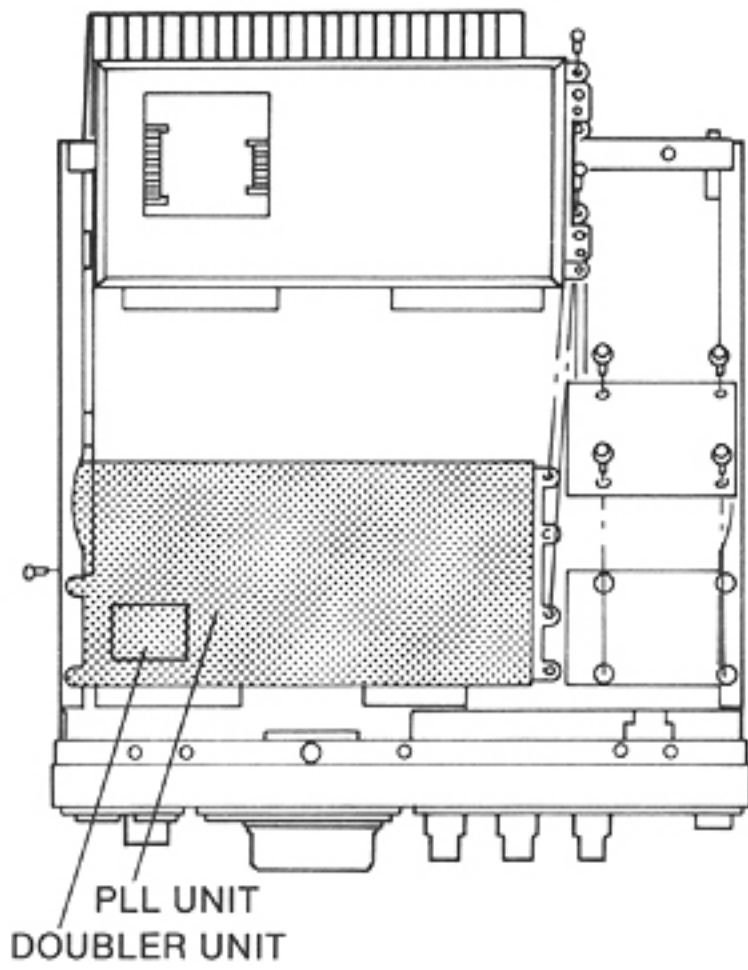

(TOP VIEW)

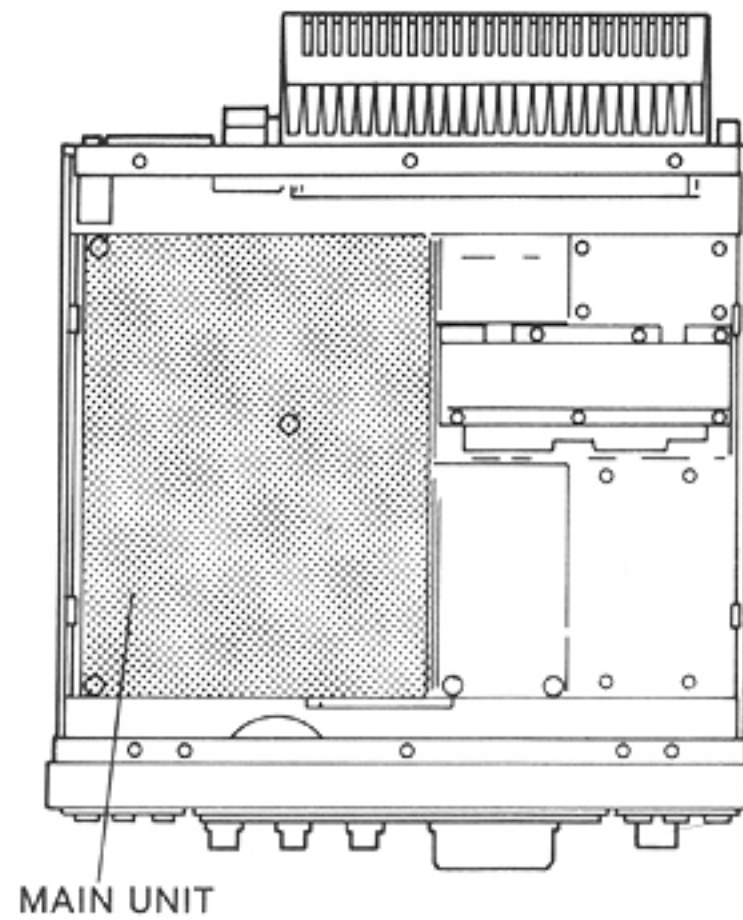

PLL UNIT

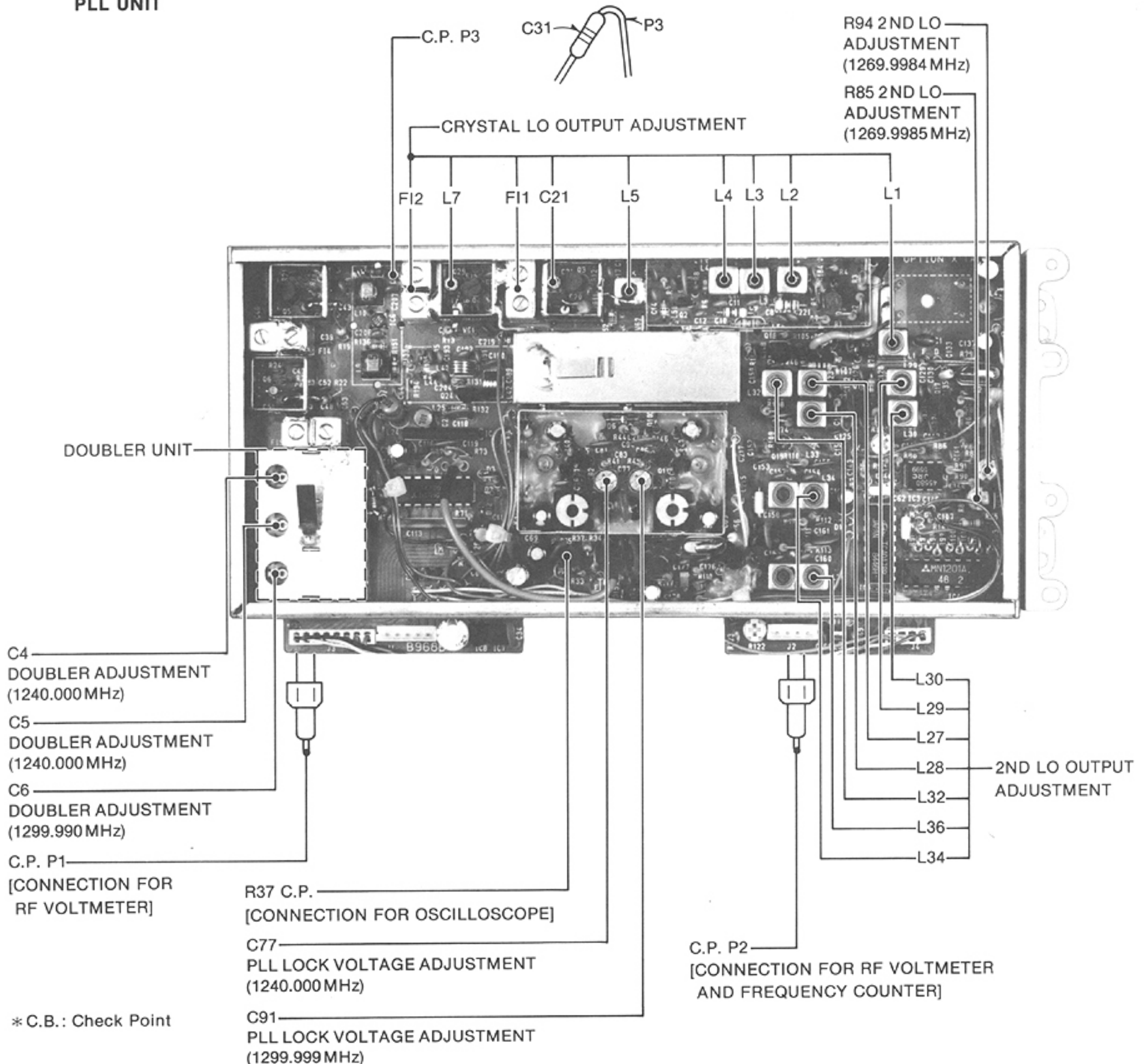

* C.B.: Check Point

MAIN UNIT

R43 C.P. BFO ADJUSTMENT

L1 FM 10.75000MHz

R71 C.P. BFO ADJUSTMENT

L7 CW-R 10.74850MHz

L8 CW-T 10.74930MHz

C47 LSB 10.75150MHz

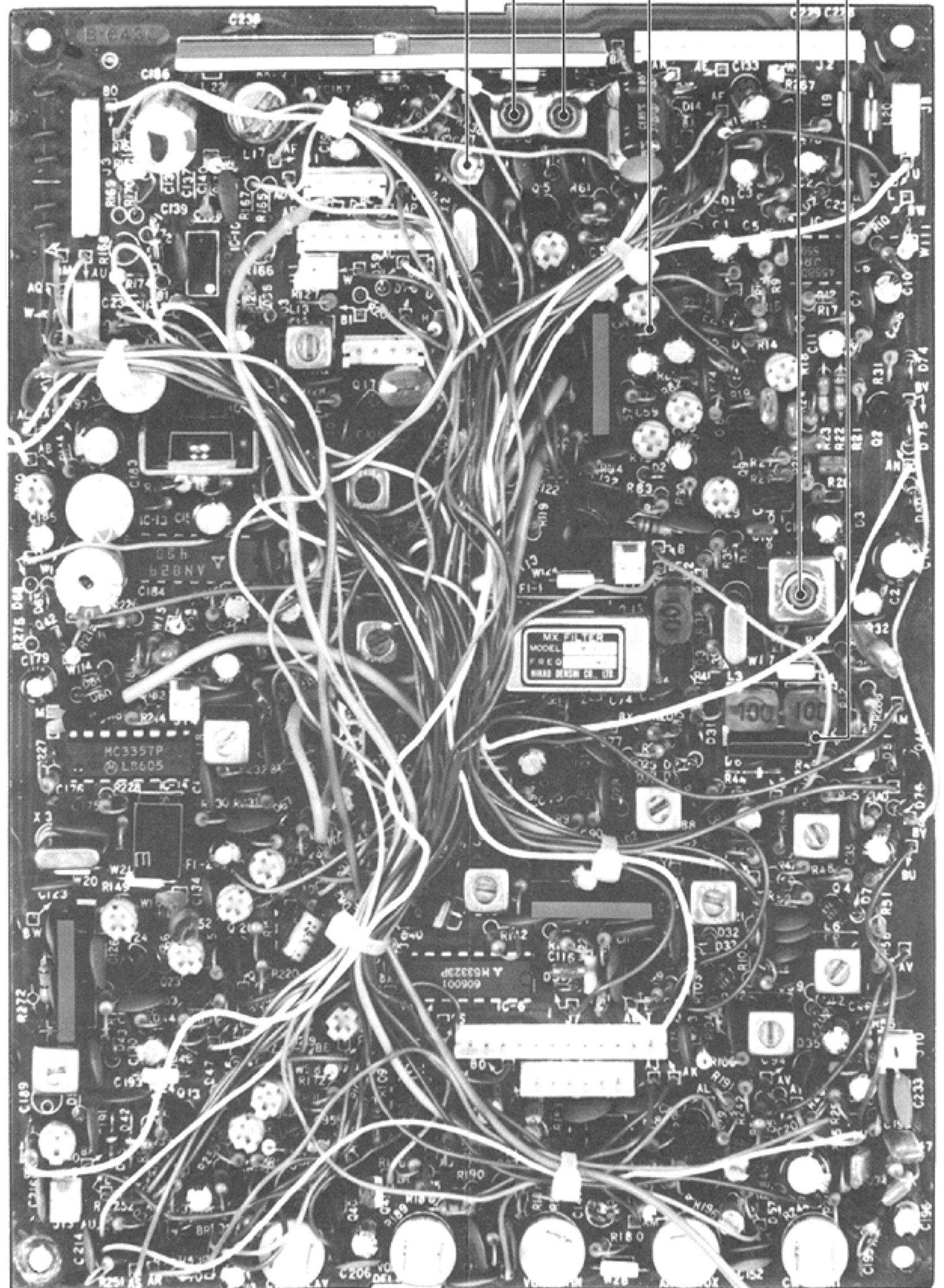

6-3 RECEIVER ADJUSTMENT

INSTRUMENTS REQUIRED	CONNECTIONS
(1) VOLTAGE REGULATED POWER SUPPLY • OUTPUT VOLTAGE : DC 13.8V • CURRENT CAPACITY : MORE THAN 8A (2) SIGNAL GENERATOR (SSG) • FREQUENCY RANGE : 0.1~1300MHz • OUTPUT VOLTAGE : 0.1μV to 32mV (-127dBm to -17dBm) (3) AC MILLIVOLTMETER • MEASURING RANGE : 0.001~4V (4) EXTERNAL SPEAKER • IMPEDANCE : 8Ω (5) OSCILLOSCOPE • FREQUENCY RANGE : DC~20MHz • MEASURING RANGE : 0.01~10V	

ADJUSTMENT	ADJUSTMENT CONDITIONS	UNIT	MEASUREMENT LOCATION	VALUE	UNIT	ADJUST
TOTAL GAIN a) FM	• Display freq.: 1270.000MHz • Mode: FM • TONE CONTROL: max. clockwise • RF GAIN CONTROL: max. clockwise • SQUELCH CONTROL: max. counterclockwise • METER: S-METER • RIT: OFF • AGC: FAST • NB: OFF • Apply RF input from SSG. 1μV (-107dBm) DEV. 5KHz/MOD. 1KHz	FRONT PANEL	S-METER	Maximum reading	FILTER	C2, C1
					RF-MIX	C1, C4, C8, C10, R15, R19
					IF	L5~7, L11, L12, L16~L19
					MAIN	L11, L12

NOTE: Repeat this adjustment several times.

b) SSB	2	• Apply RF input Adjust SSG until the S-METER indicates 2~3.	FRONT	S-METER	Maximum reading	MAIN	L16
	3		REAR PANEL	Connect an AC MILLIVOLTMETER to the external jack with 8Ω load.	Maximum AF output		L8
	4	• Mode: USB • Apply RF input from SSG. 0.1μV (-127dBm) MOD. OFF					L9, L11, L12, L14, L15
	5	• Apply RF input from SSG. 1μV (-107dBm) signal	FRONT PANEL	S-METER	Maximum reading		L13
	6	• Mode: FM • Apply RF input from SSG. 1μV (-107dBm)/MOD. 1KHz					L11, L12
	7	• Mode: USB • Apply RF input from SSG. 0.1μV (-127dBm) MOD. OFF	REAR PANEL	Connect an AC MILLIVOLTMETER to the external jack.	Maximum AF output		L9, L14, L15

Sensitivity: FM Less than 0.22μV (-120dBm) for 12dB SINAD.
 Less than 0.32μV (-117dBm) for 20dB noise quieting.
 SSB, CW Less than 0.16μV (-123dBm) for 10dB S+N/N.

S-METER a) FM	1	• Display freq.: 1270.000MHz • Mode: FM • Apply RF input from SSG. 1μV (-107dBm) DEV. 3.5KHz/MOD. 1KHz	FRONT PANEL	S-METER	S9	MAIN	R149	
	2	• Apply RF input from SSG. 32μV (-77dBm) signal			S9+60dB (full scale)		R152	
	b) SSB	3			• Mode: USB • Apply RF input from SSG. 1μV (-107dBm) MOD. OFF		S5	R160
		4			• Apply RF input from SSG. 1mV (-47dBm) signal		S9+60dB (full scale)	R164

NOTE: Repeat steps 1 to 4 so that S-METER indicates +3~-3dB at all in-band.

UNIT LOCATION

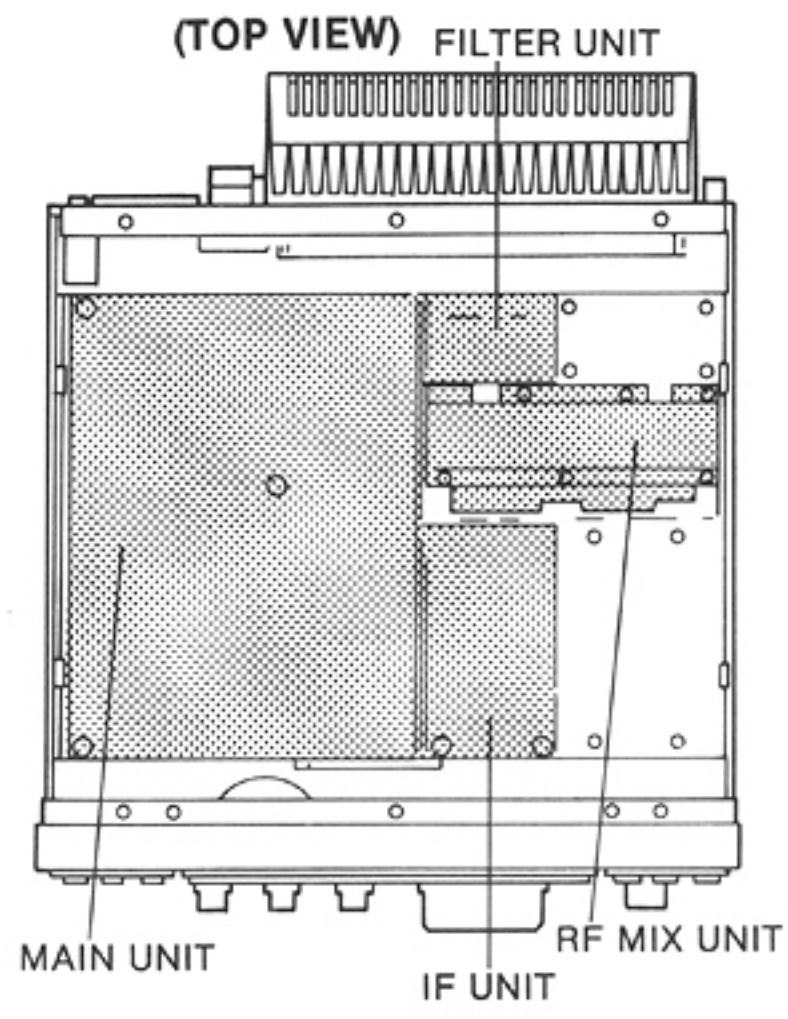

FILTER UNIT

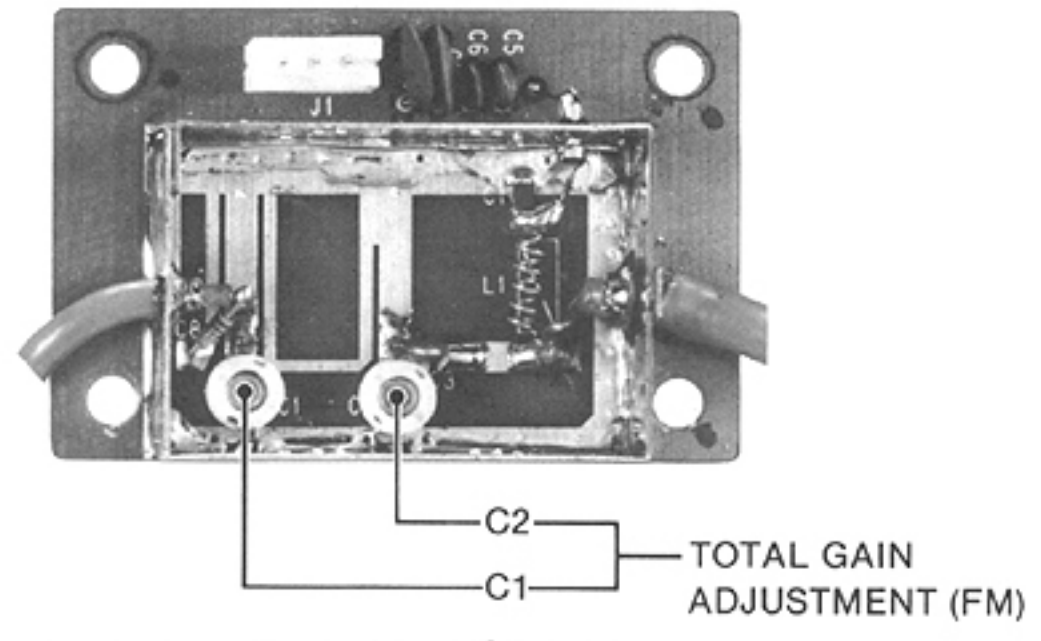

RF MIX UNIT

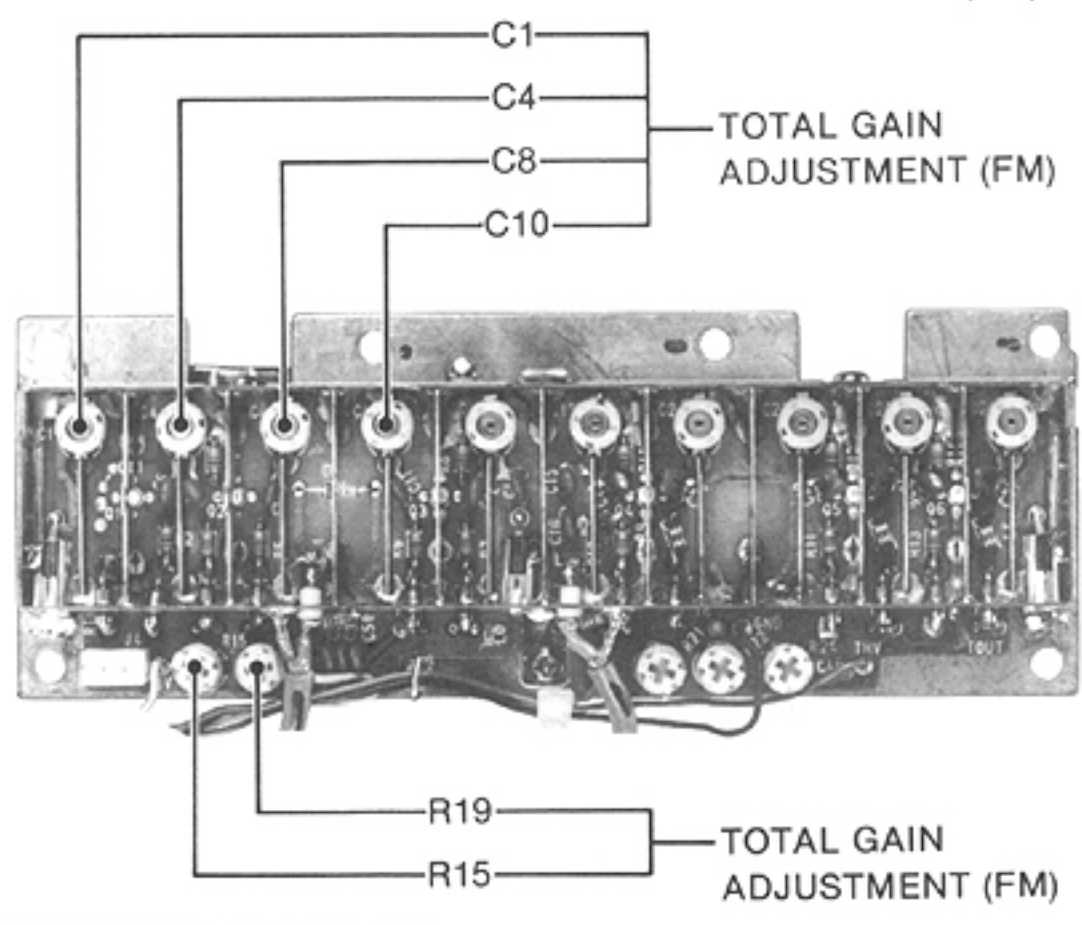

IF UNIT

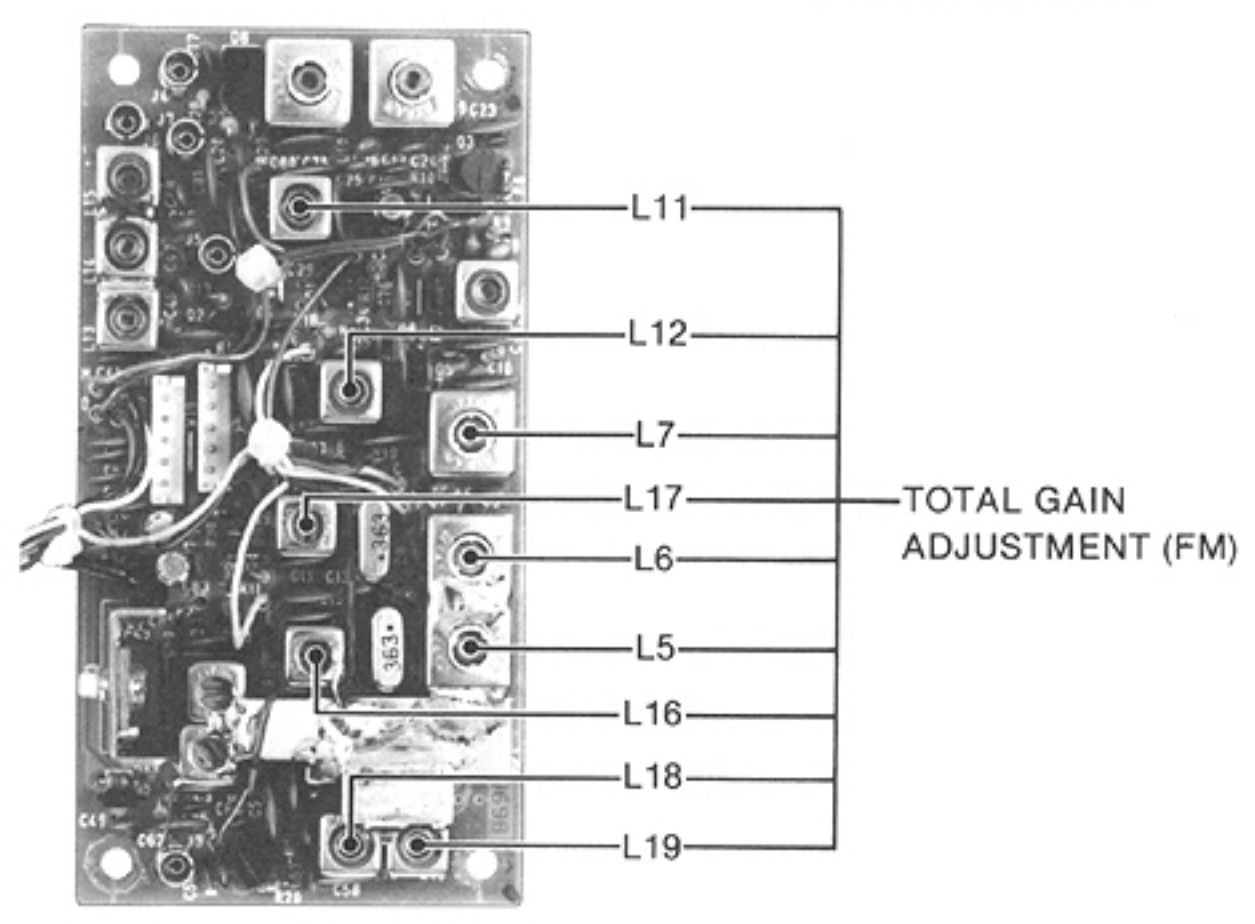

MAIN UNIT

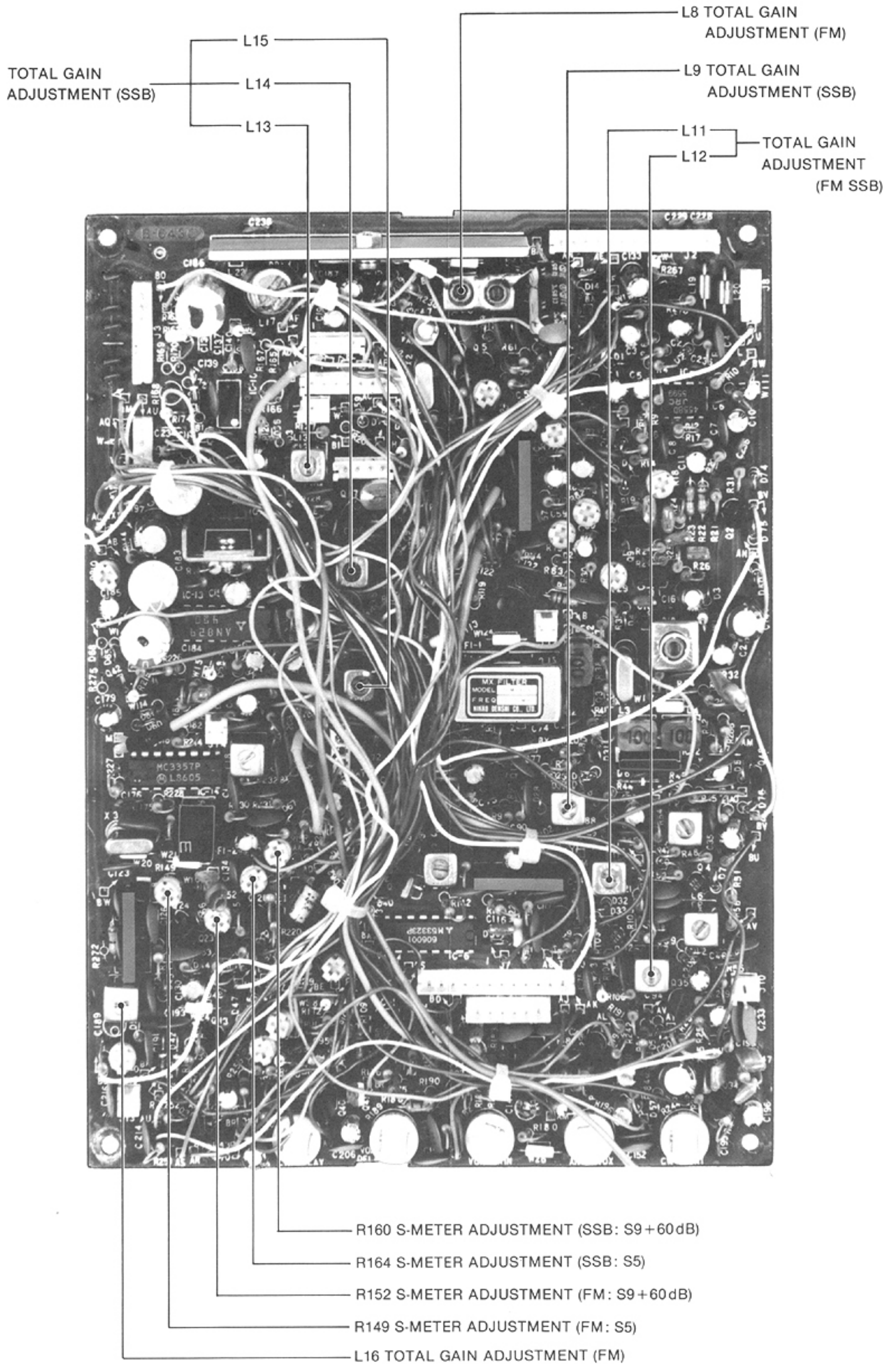

ADJUSTMENT		ADJUSTMENT CONDITIONS	UNIT	MEASUREMENT LOCATION	VALUE	UNIT	ADJUST
FM CENTER METER	1	<ul style="list-style-type: none"> • Display freq.: 1270.000MHz • Mode: FM • METER SWITCH: CENTER METER (Cut off the SSG signal) 	FRONT PANEL	CENTER METER	Center	MAIN	R113
	2	<ul style="list-style-type: none"> • Apply RF input from SSG. 3.2μV (-97dBm) DEV. 3.5KHz/MOD. 1KHz • Adjust SSG frequency for a maximum CENTER METER indication in the + direction 		RF OUTPUT METER	80% of full scale		R114
SQUELCH a) FM	1	<ul style="list-style-type: none"> • Display freq.: 1270.000MHz • Mode: FM • SQUELCH CONTROL: 9 o'clock position 	FRONT PANEL	RECEIVE INDICATOR	RECEIVE INDICATOR just goes out.	MAIN	R210
	b) SSB	2					<ul style="list-style-type: none"> • Mode: USB
RF GAIN	1	<ul style="list-style-type: none"> • Display freq.: 1270.000MHz • Mode: USB • RF GAIN CONTROL: 9 o'clock position 	FRONT PANEL	S-METER	Full scale.	FRONT	R8
RIT	1	<ul style="list-style-type: none"> • Display freq.: 1270.000MHz • Mode: USB • RIT SWITCH: ON/OFF • RIT CONTROL: Center • Apply RF input from SSG. 1μV (-107dBm) signal 	REAR PANEL	Connect a speaker to the external speaker jack.	Adjust AF output to same tone.	DC-DC	R12
NOISE BLANKER	1	<ul style="list-style-type: none"> • Display freq.: 1270.000MHz • Mode: USB • NOISE BLANKER SWITCH: ON • Apply pulse noise to the antenna connector. (Adjust the level of pulse noise so that S-METER indicates 2~3.) 	REAR PANEL	Connect a speaker to the external speaker jack. (or S-METER)	Adjust AF output (noise level) to minimum. (or S-METER minimum indication)	MAIN	L10

UNIT LOCATIONS

(BOTTOM VIEW)

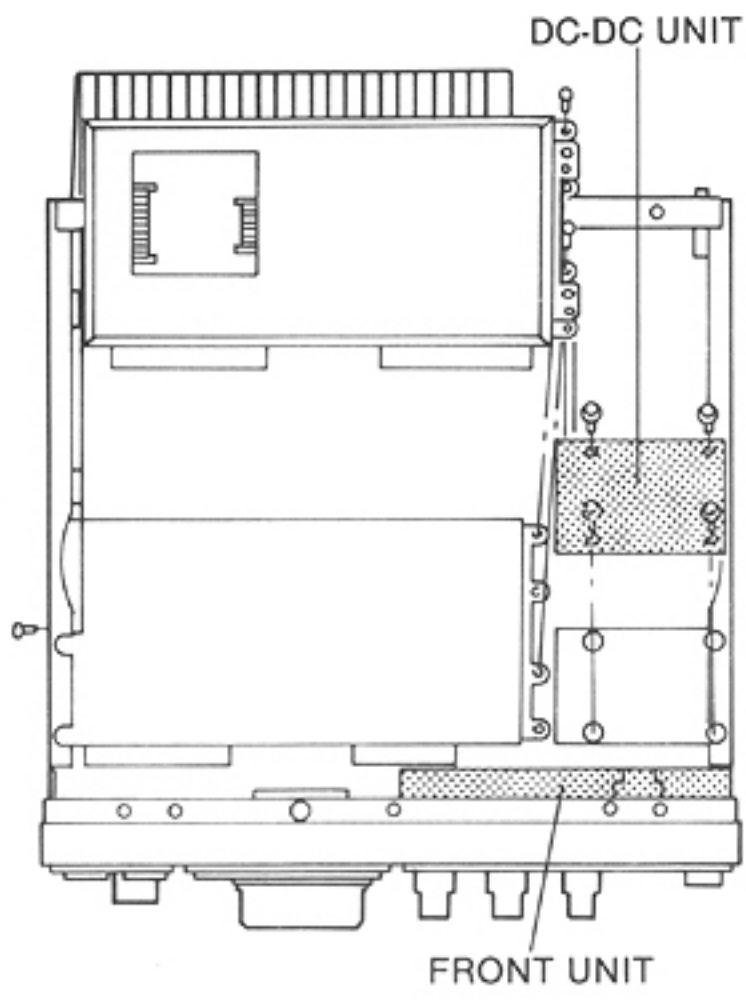

(TOP VIEW)

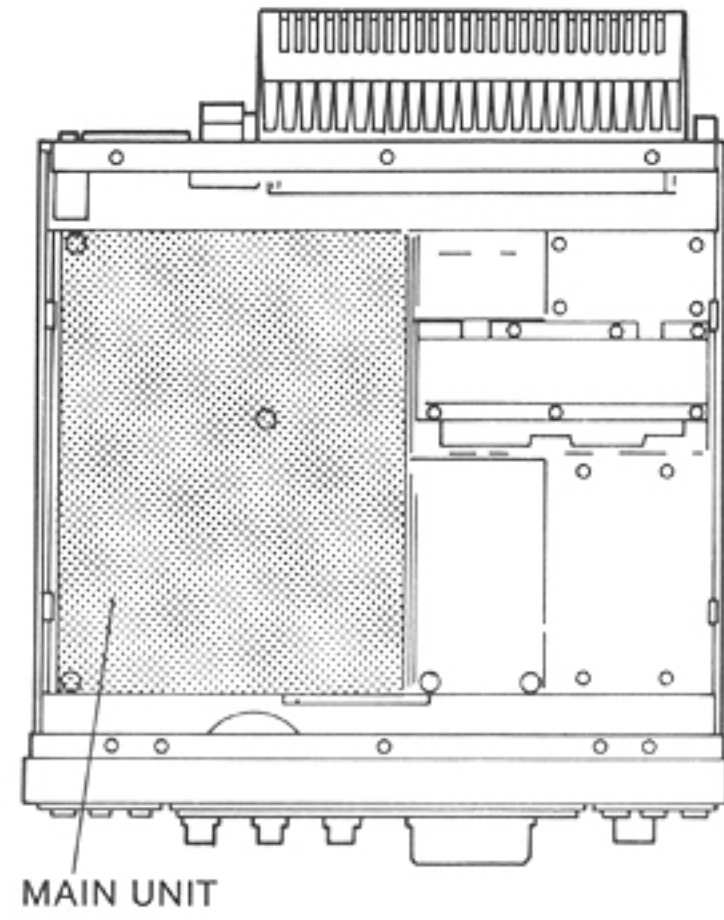

DC-DC UNIT

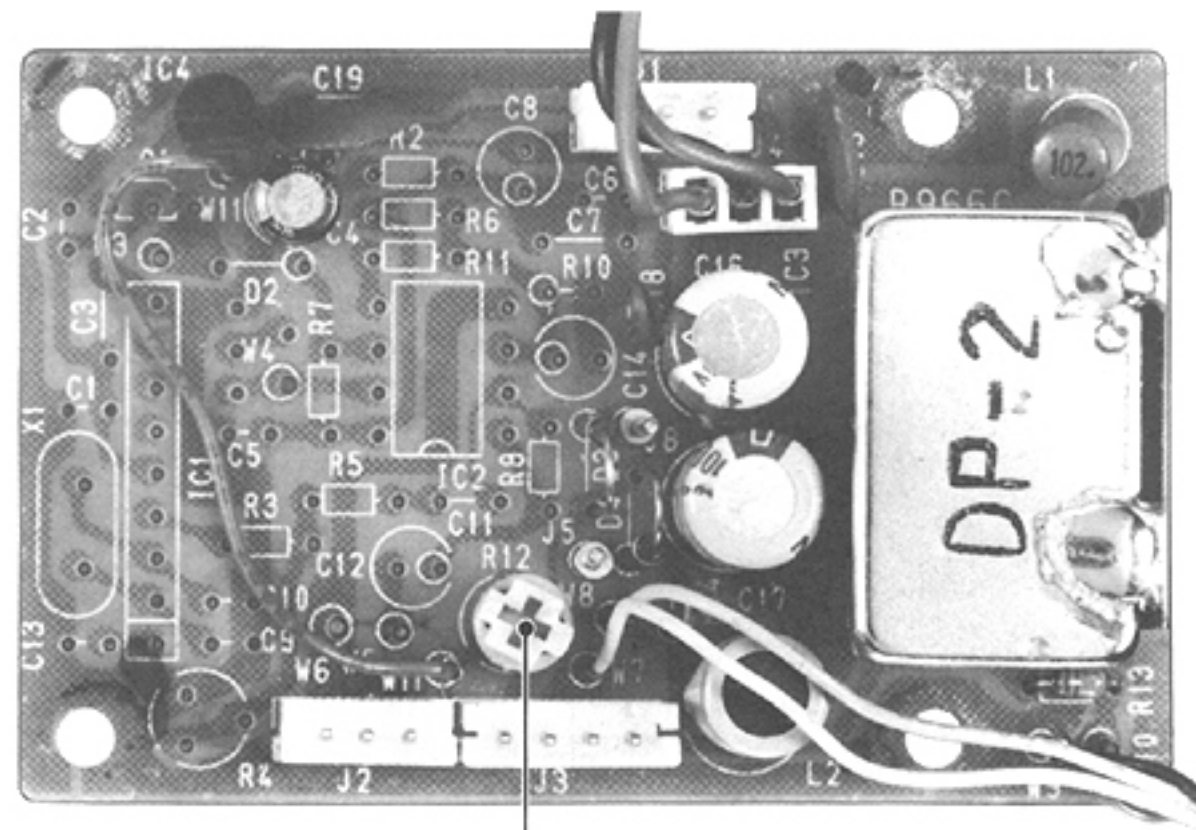

R12 RIT ADJUSTMENT

FRONT UNIT

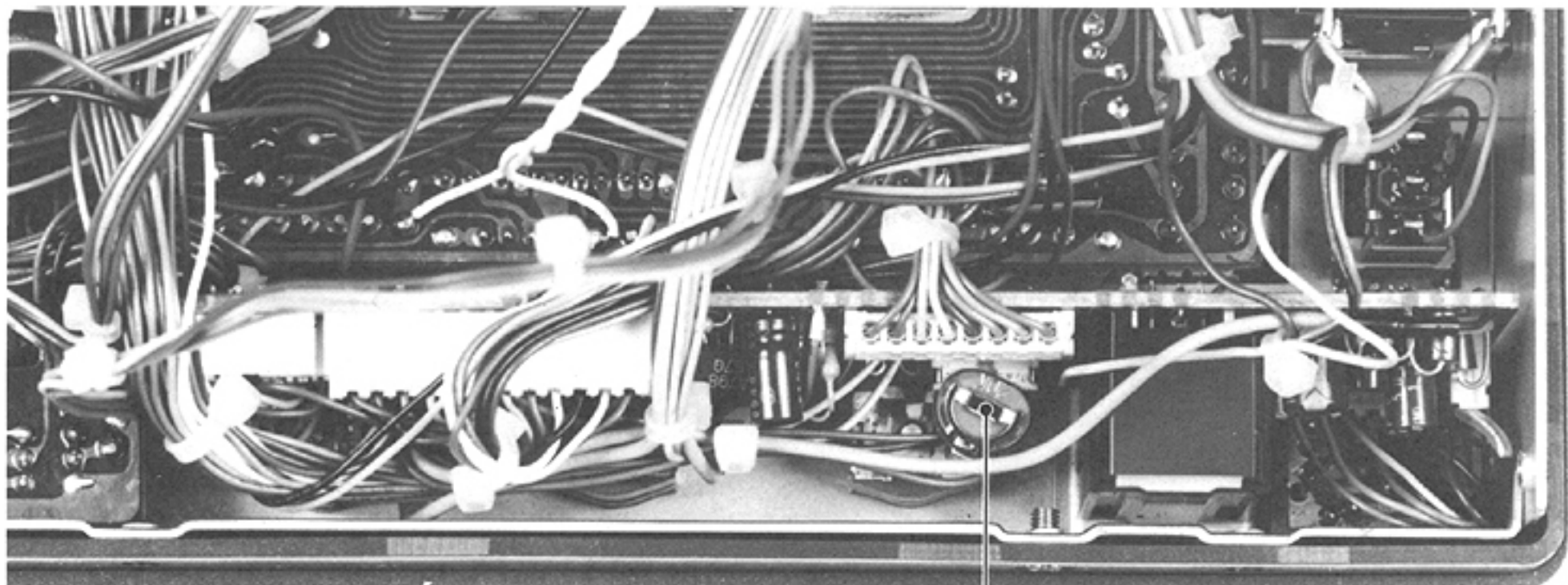

R8 RF GAIN ADJUSTMENT

MAIN UNIT

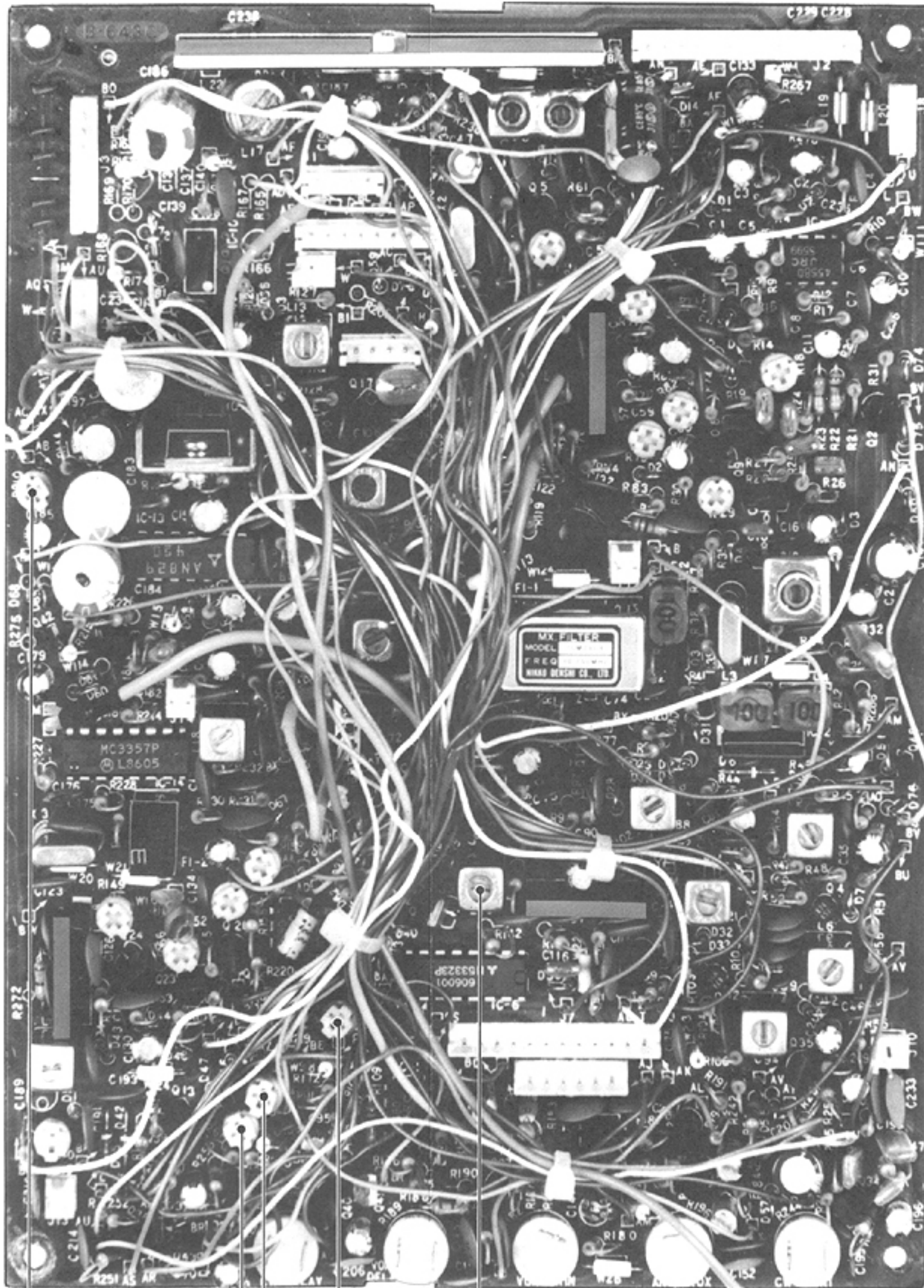

- L10 NOISE BLANKER ADJUSTMENT
- R224 SQUELCH ADJUSTMENT (SSB)
- R113 — FM CENTER METER ADJUSTMENT
- R114 — FM CENTER METER ADJUSTMENT
- R210 SQUELCH ADJUSTMENT (FM)

6-4 TRANSMITTER ADJUSTMENT (MODULE-TYPE)

INSTRUMENTS REQUIRED			CONNECTIONS				
(1) VOLTAGE REGULATED POWER SUPPLY • OUTPUT VOLTAGE : DC 13.8V • CURRENT CAPACITY : MORE THAN 8A (2) RF VOLTMETER • FREQUENCY RANGE : 0.1~1300MHz • MEASURING RANGE : 0.001~10V (3) RF POWER METER (TERMINATED) • MEASURING RANGE : 20W • FREQUENCY RANGE : 1240~1300MHz • IMPEDANCE : 50Ω • SWR : LESS THAN 1:1.2 (4) AF OSCILLATOR • OUTPUT FREQUENCY : 200~3000Hz • OUTPUT VOLTAGE : 0~300mV (5) AC MILLIVOLTMETER • MEASURING RANGE : 0.001~4V (6) FM DEVIATION METER • FREQUENCY RANGE : 100~200MHz • MEASURING RANGE : 0~±10kHz (7) OSCILLOSCOPE • FREQUENCY RANGE : DC~20MHz • MEASURING RANGE : 0.01~10V (8) VOLTMETER • INPUT IMPEDANCE : 50KΩ/V OR BETTER			<p>AF FILTER LPF: 20KHz HPF: 50Hz DEVIATION: 10KHz DEEMPHASIS: OFF DEV. SENS: P-P/2</p> <p>PIN No. 1: AG INPUT No. 7: GND No. 5: } SHORT No. 6: }</p>				
ADJUSTMENT	ADJUSTMENT CONDITIONS	UNIT	MEASUREMENT LOCATION	VALUE	UNIT	ADJUST	
OUTPUT POWER	1	<ul style="list-style-type: none"> Display freq.: 1270.000MHz Mode: FM Short R174 [D4] and GND on the MAIN UNIT to prevent ALC operating. Transmit mode 	IF	Pull out connector P1 (from RF-MIX UNIT) and then connect an RF power meter to J4.	Maximum output: more than +5dBm	MAIN IF	L5, L6 L1, L2, L8~L10
	NOTE: Repeat above step for 2 or 3 times. After adjustment, connect the J4 to restore the original state of the unit.						
	2	<ul style="list-style-type: none"> Display freq.: 1270.000MHz Mode: FM 	RF MIX	Pull out connector P2 (from PA-UNIT) and then connect an RF power meter to J3.	Maximum output	RF MIX	C17, C21, C22, C25, C28
	3	<ul style="list-style-type: none"> Display freq.: 1240.000MHz 					R21, R22, R24
	4	<ul style="list-style-type: none"> Display freq.: 1240.000MHz 1299.000MHz 					C17, C25
	NOTE: Adjust R21, R22 and R23 for the output powerbalance, it necessary. After adjustment, connect P1 from PA UNIT to J3.						
5	<ul style="list-style-type: none"> Display freq.: 1270.000MHz Mode: FM 	REAR PANEL	Connect an RF power meter to the antenna connector.	Maximum output: more than 14.5W	PA	C10, C14, C33, C34	
NOTE: Repeat step 5 several times.							
6	<ul style="list-style-type: none"> Display freq.: 1270.000MHz Mode: FM 	REAR PANEL	Connect an RF power meter to the antenna connector.	Output: more than 14.5W	PA	C33, C34	
NOTE: After adjustment, cut the shorted portion between R174 (D4 side) and ground (at step 1).							
ALC	1	<ul style="list-style-type: none"> Display freq.: 1270.000MHz Mode: FM Short D5 and GND on the PA UNIT. 	REAR PANEL	Connect an RF power meter to the antenna connector.	11W	PA	R15
	2		PA	Connect a voltmeter to C62 (W39 side).	3V		R6
	3	<ul style="list-style-type: none"> Display freq.: Choose a frequency which makes maximum current. 	REAR PANEL	Ammeter (included in a power supply)	6A		R15
(a) FM LOW POWER	4	<ul style="list-style-type: none"> Display freq.: 1270.000MHz RF power: max. counterclockwise Cut the shorted portion D5 and GND on the PA UNIT (at step 1). 		Connect an RF power meter to the antenna connector.	1W		R23

ADJUSTMENT		ADJUSTMENT CONDITIONS	UNIT	MEASUREMENT LOCATION	VALUE	UNIT	ADJUST
(b) FM HIGH POWER	5	• RF POWER: max. clockwise	REAR PANEL	Connect an RF power meter to the antenna connector.	11W	PA	R24
(c) SSB POWER	NOTE: Verify the output powers are 10~12W at 1240.000MHz and 1299.999MHz.						
	6	• Display freq.: 1270.000MHz • Mode: USB • MIC GAIN CONTROL: Center • Apply AF signal 1.5KHz/20mV to MIC connector from an AF oscillator.	REAR PANEL	Connect an RF power meter to the antenna connector.	10W	MAIN	R82
	7	• Apply AF signal (1.5KHz/20mV) to MIC connector from an AF oscillator.			10W		Verify
(d) CW POWER	8	• Mode: CW • Transmit mode and KEY DOWN			10W		R63
RF METER	1	• Display freq.: 1270.000MHz • Mode: FM • RF POWER CONTROL: max. clockwise	FRONT PANEL	RF voltmeter	80% of full scale deflection	MAIN	R240
CARRIER BALANCE	1	• Display freq.: 1299.999MHz • Mode: USB or LSB • Measure the output voltage at each mode (USB, LSB). • RF POWER CONTROL: max. clockwise	REAR PANEL	Connect an RF voltmeter to the antenna connector.	Minimum output voltage.	MAIN	R72, R75
FM DEVIATION	1	• Display freq.: 1270.000MHz • Mode: FM • MIC GAIN CONTROL: Center • Apply AF input (1KHz/2mV) to the MIC CONNECTOR	IF	Connect an oscilloscope to J4.	Symmetrical response about the horizontal base line.	MAIN	R18
	2	• Increase AF input by 20dB. (1KHz/20mV)		Connect a deviation meter to J4.	±4.8kHz		R29
	3	• Decrease AF input by 20dB. (1KHz/2mV)			±3.5kHz~±4.5kHz		Verify
TONE DEVIATION (#03 Only)	1	• Display freq.: 1270.000MHz • Mode: FM • SUBAUDIBLE TONE SWITCH: ON • TONE SELECT SWITCH: Set to ON position and select TONE No. 08 by using TUNING CONTROL. • Mic input: none • Transmit	IF	Connect a deviation meter to J4.	0.6kHz~0.65kHz	LOGIC	R57
TONE DEVIATION (#02 Only)	1	• Display freq.: 1270.000MHz • Mode: FM • TONE SWITCH: ON • Mic input: none • Transmit	IF	Connect a deviation meter to J4.	3.5kHz/DEV.	DC-DC	R4

UNIT LOCATIONS

(BOTTOM VIEW)

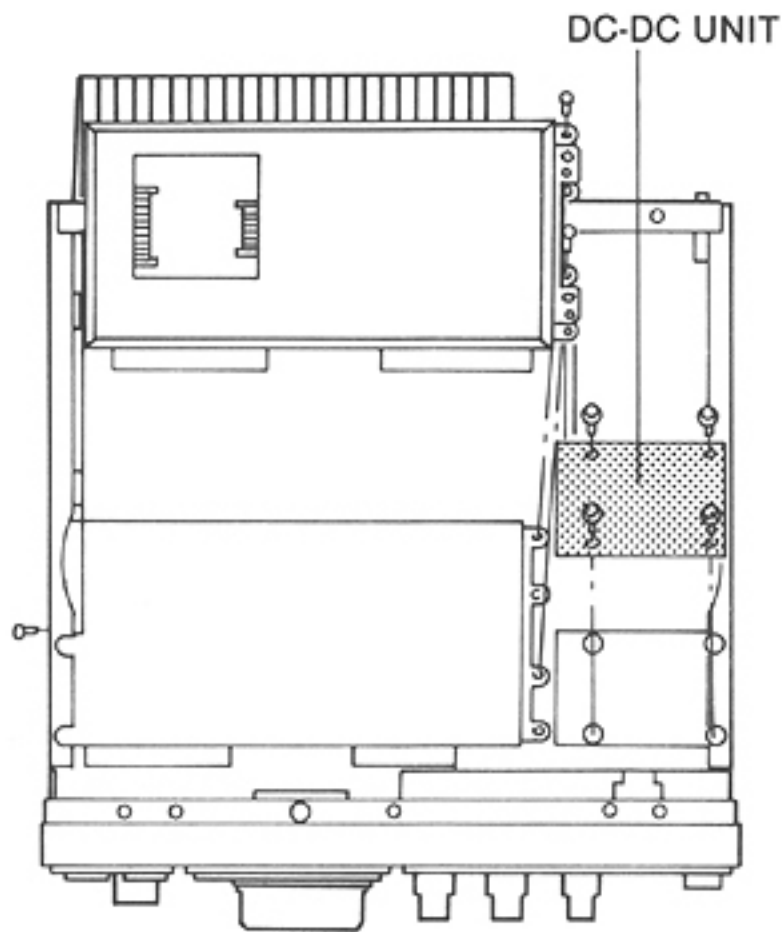

(TOP VIEW)

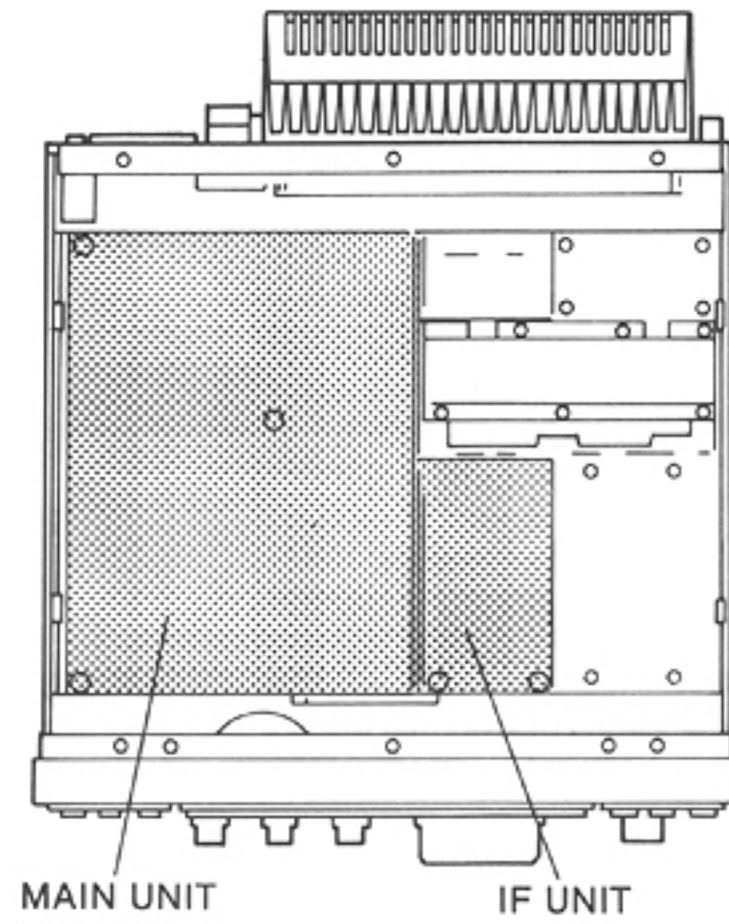

IF UNIT

J4 C.P. (RF VOLTmeter/
OSCILLOSCOPE/
FM DEVIATION
METER)

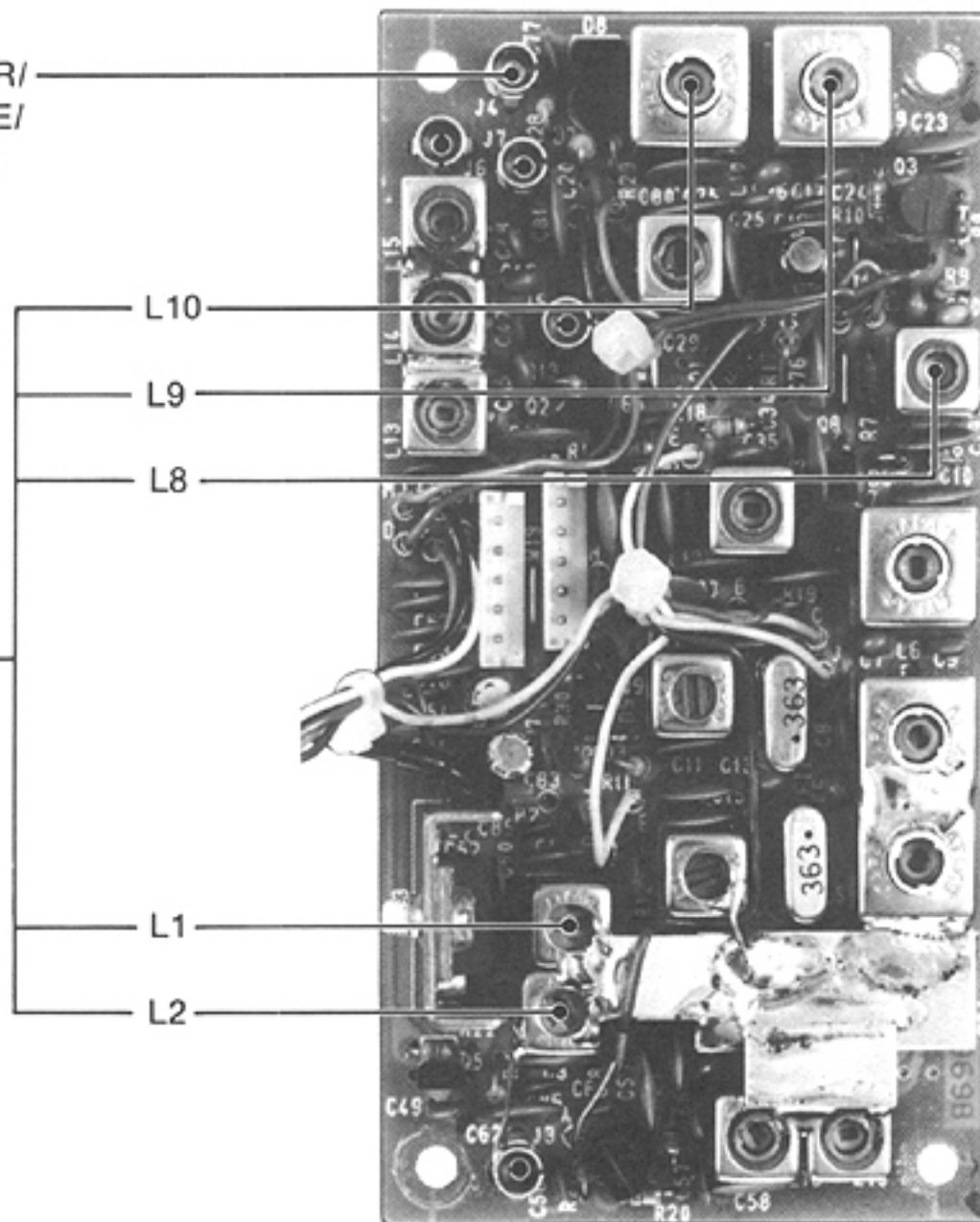

DC-DC UNIT
(#02 Only)

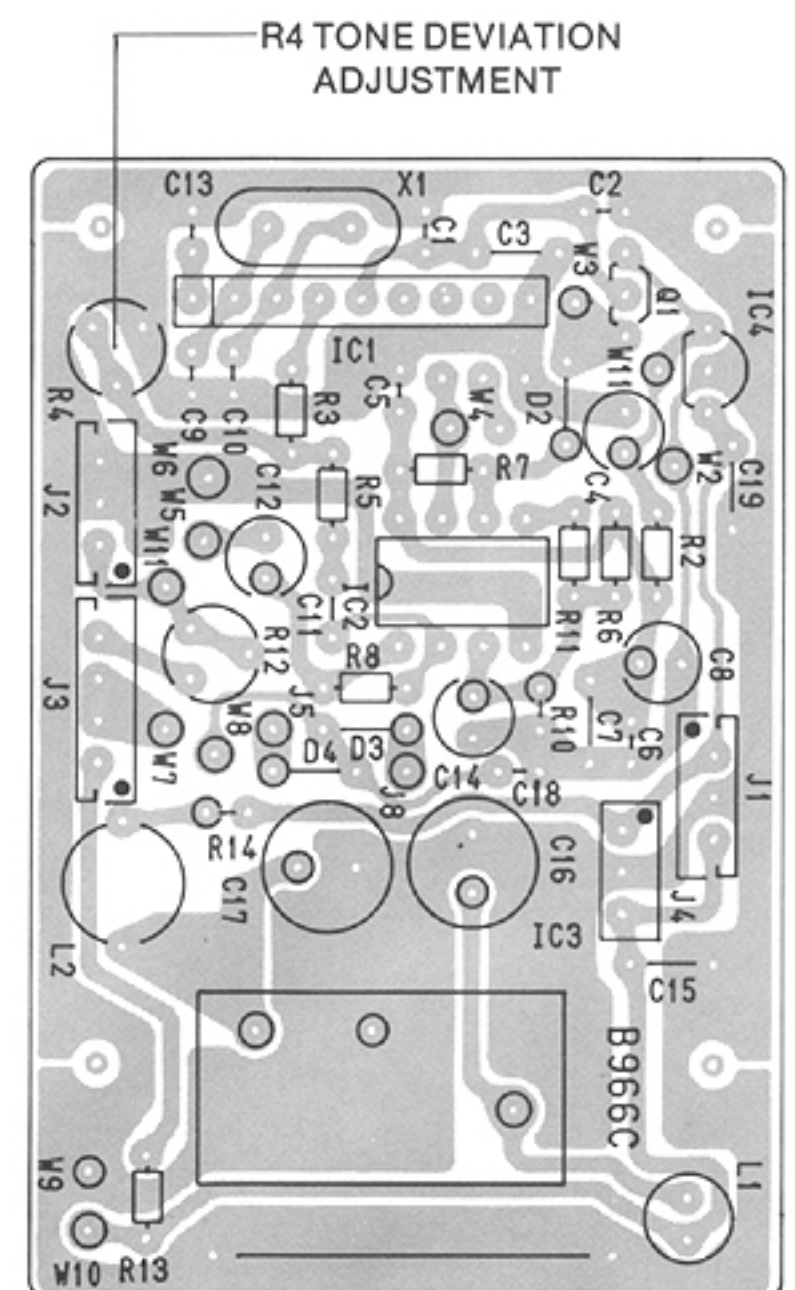

*C.P.: Check Point

MAIN UNIT

- R75 CARRIER BALANCE ADJUSTMENT
- R72 CARRIER BALANCE ADJUSTMENT
- R63 ALC ADJUSTMENT (CW: 10W)
- R174 J.P. (FOR ALC ADJUSTMENT)
- R82 ALC ADJUSTMENT (SSB: 10W)
- R29
- R18
- FM DEVIATION ADJUSTMENT

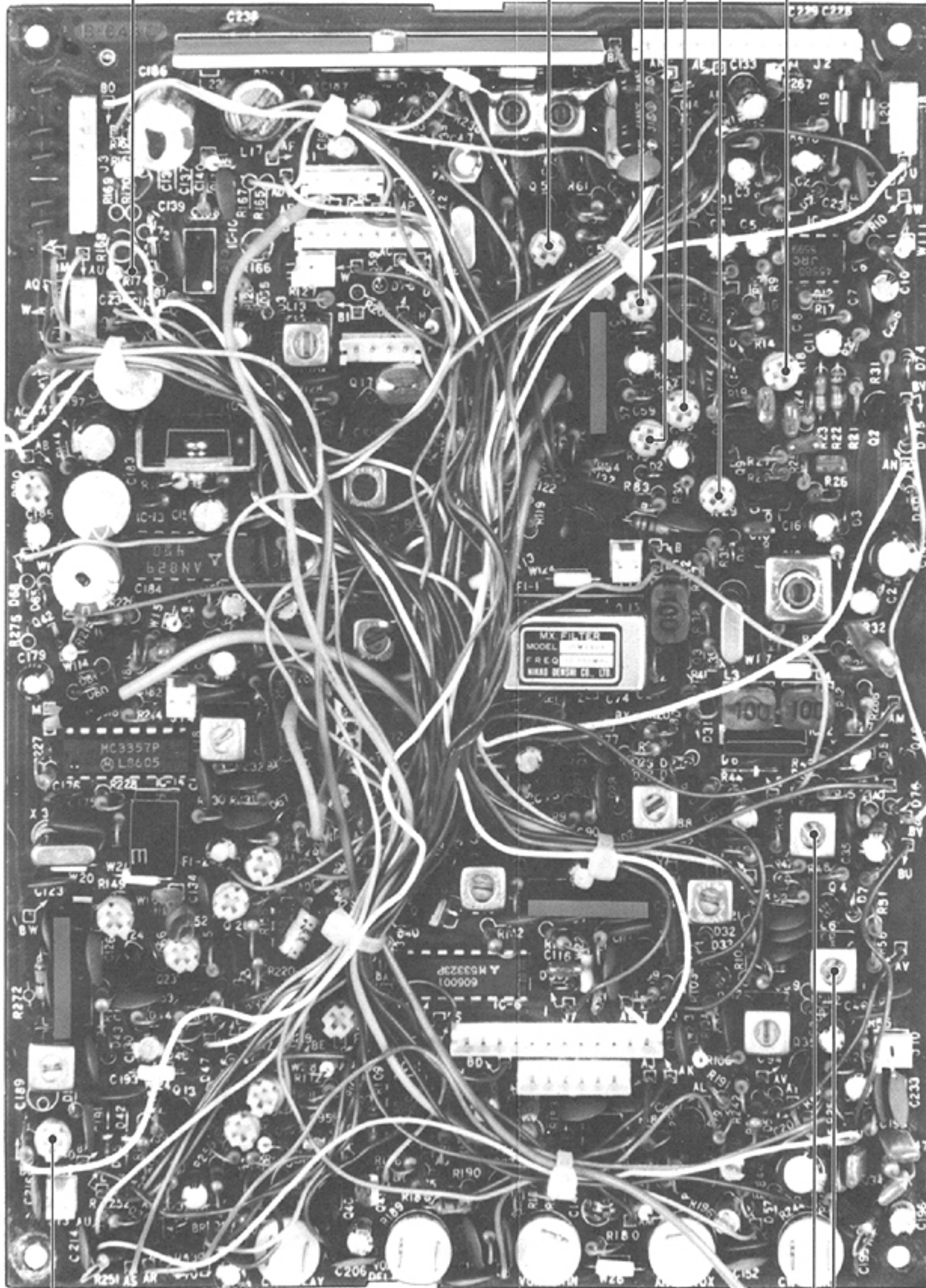

R240 RF METER ADJUSTMENT

L5 OUTPUT POWER ADJUSTMENT

L6 OUTPUT POWER ADJUSTMENT

* J.P.: Jumper Point

UNIT LOCATIONS

(BOTTOM VIEW)

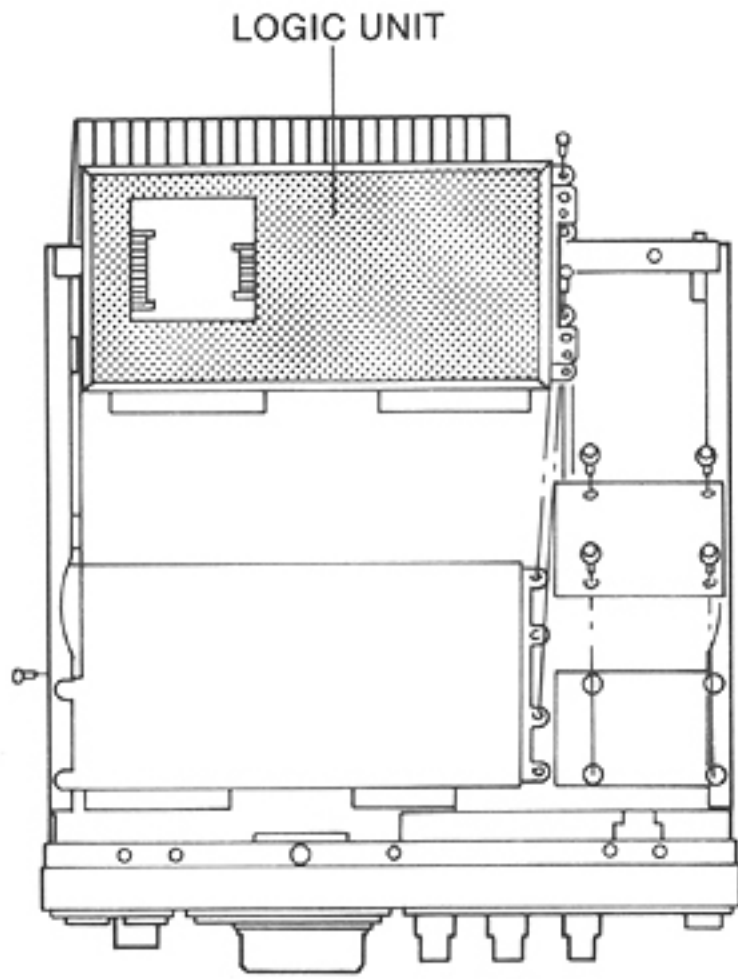

(TOP VIEW)

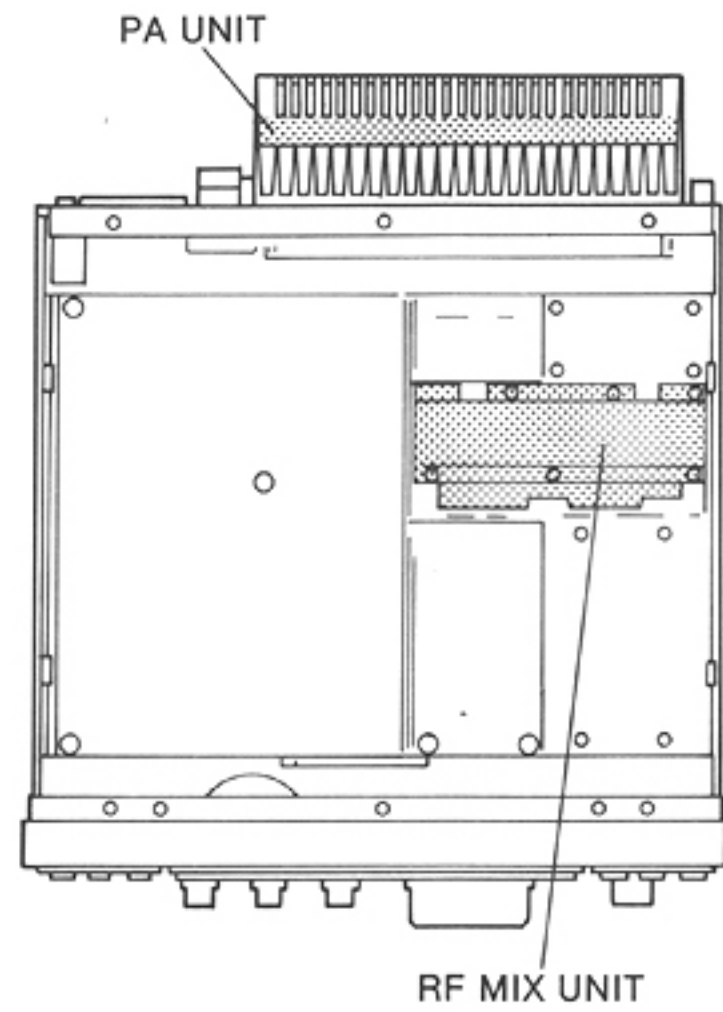

LOGIC UNIT (#03 Only)

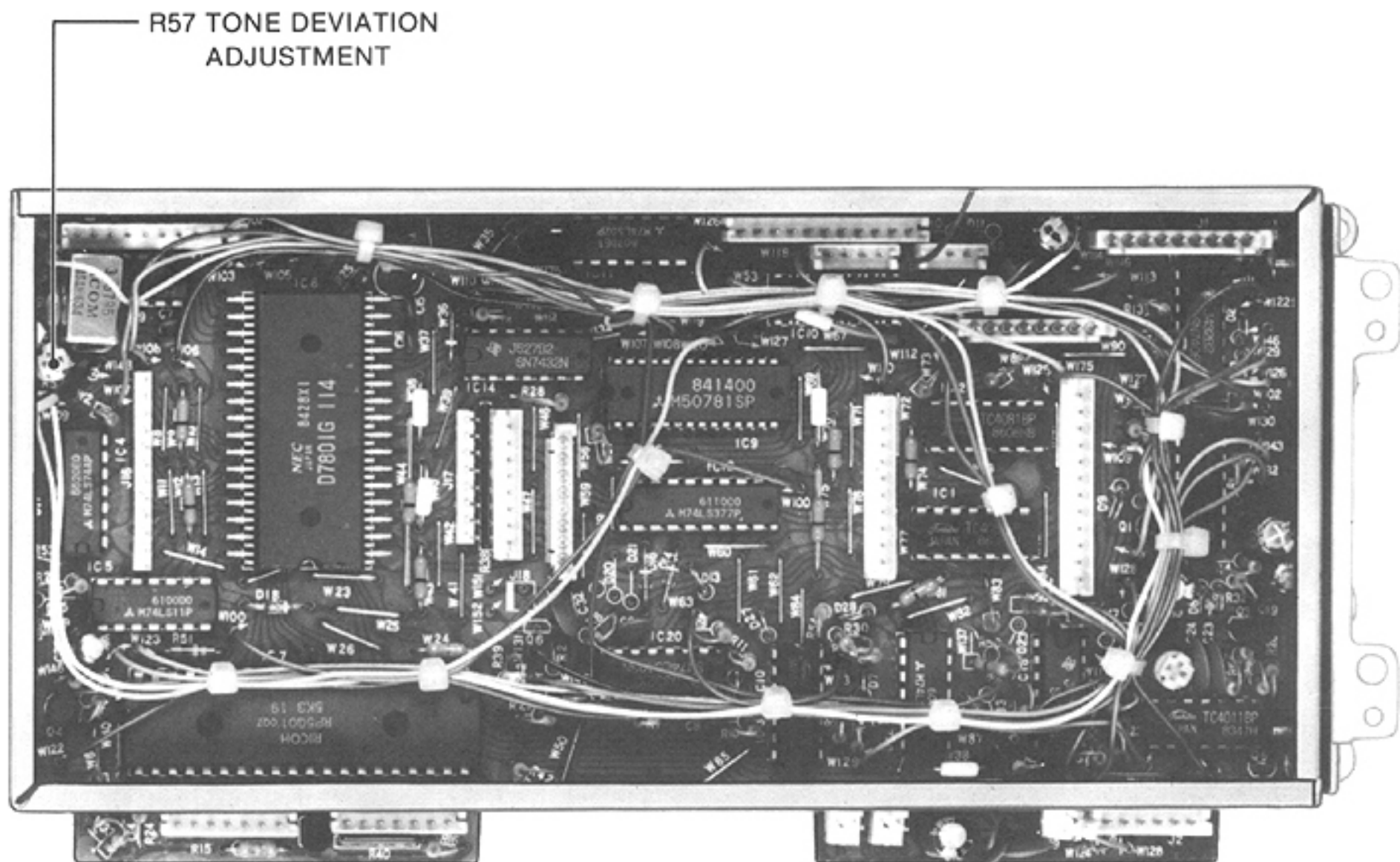

RF MIX UNIT

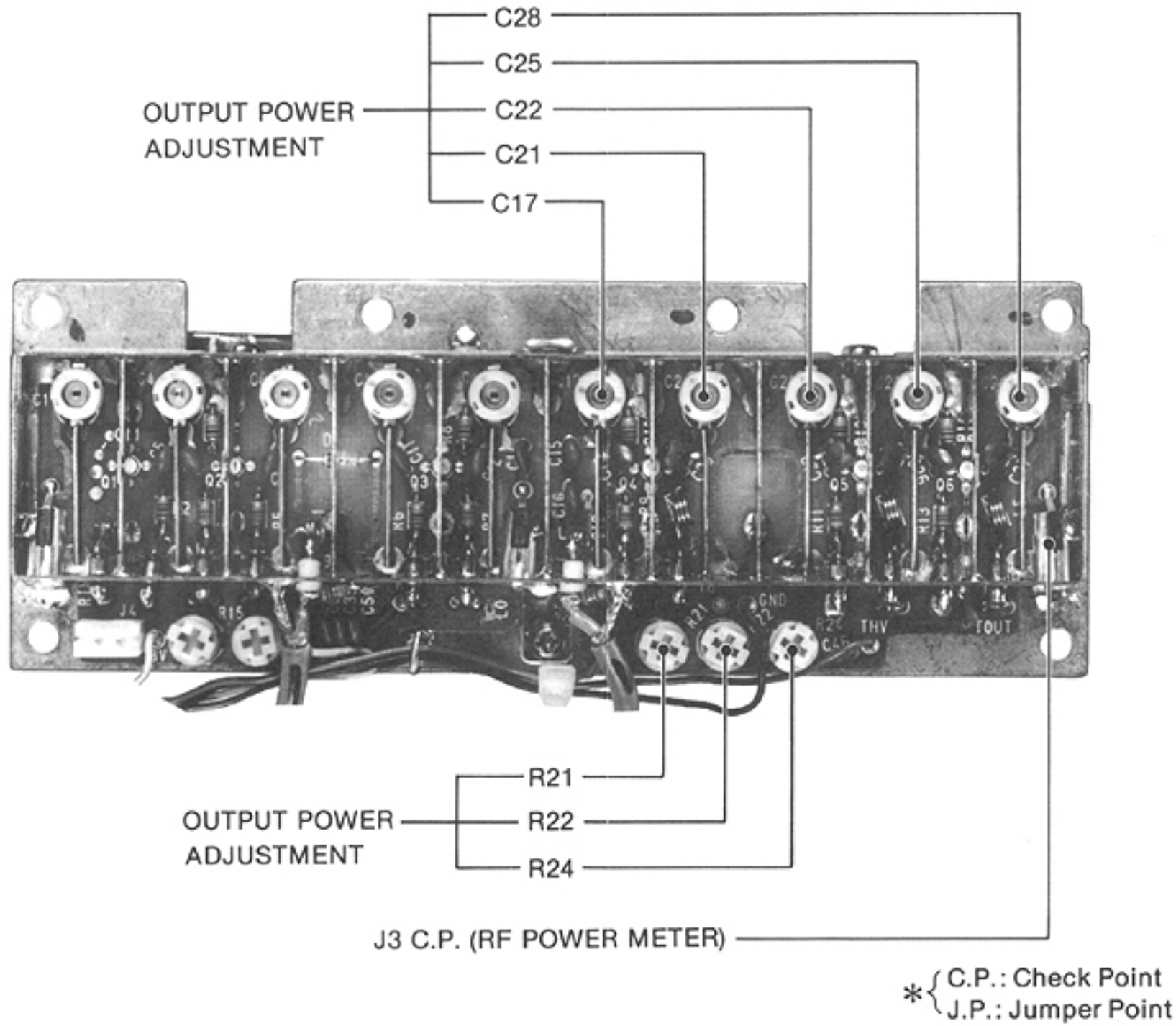

PA UNIT

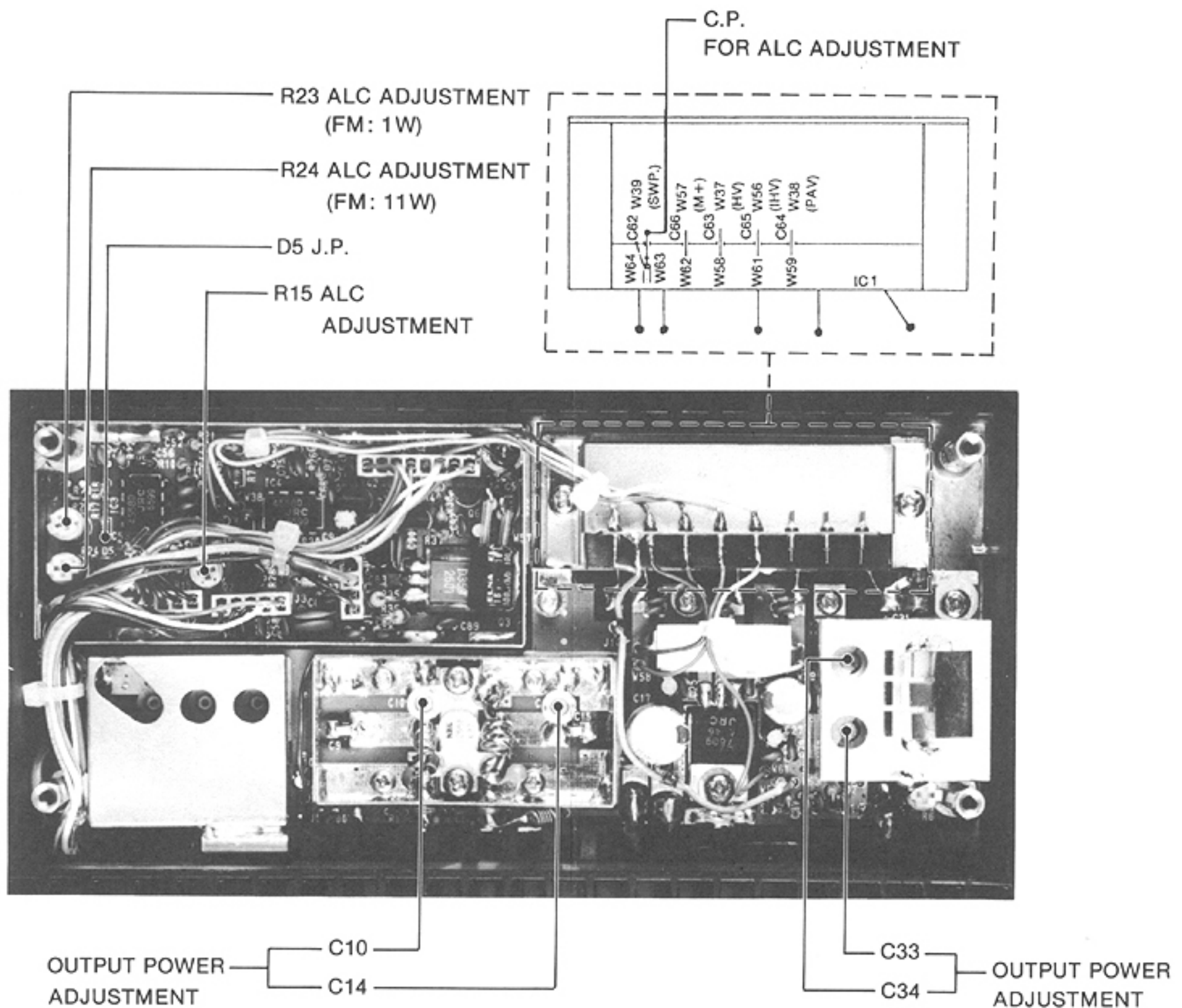

6-5 TRANSMITTER ADJUSTMENT (TRANSISTOR-TYPE)

INSTRUMENTS REQUIRED		CONNECTIONS					
(1) VOLTAGE REGULATED POWER SUPPLY • OUTPUT VOLTAGE : DC 13.8V • CURRENT CAPACITY : MORE THAN 8A (2) RF VOLTMETER • FREQUENCY RANGE : 0.1~1300MHz • MEASURING RANGE : 0.001~10V (3) RF POWER METER (TERMINATED) • MEASURING RANGE : 20W • FREQUENCY RANGE : 1240~1300MHz • IMPEDANCE : 50Ω • SWR : LESS THAN 1: 1.2 (4) AF OSCILLATOR • OUTPUT FREQUENCY : 200~3000Hz • OUTPUT VOLTAGE : 0~300mV (5) AC MILLIVOLTMETER • MEASURING RANGE : 0.001~4V (6) FM DEVIATION METER • FREQUENCY RANGE : 100~200MHz • MEASURING RANGE : 0~±10kHz (7) OSCILLOSCOPE • FREQUENCY RANGE : DC~20MHz • MEASURING RANGE : 0.01~10V		<p> (CONNECTIONS OF MIC CONN. [8 PIN]) PIN No. 1: AG INPUT No. 7: GND No. 5: } SHORT No. 6: } </p>					
ADJUSTMENT	ADJUSTMENT CONDITIONS	UNIT	MEASUREMENT LOCATION	VALUE	UNIT	ADJUST	
OUTPUT POWER	1	<ul style="list-style-type: none"> Display freq.: 1270.000MHz Mode: FM Short R174 (D4 side) and GND on the MAIN UNIT to prevent ALC operating. 	IF	Pull out connector P1 (from RF-MIX UNIT) and then connect an RF power meter to J4.	Maximum output: more than +5dBm	MAIN	L5, L6 L1, L2, L8~L10
	NOTE: Repeat above step for 2 or 3 times. After adjustment, connect the J4 to restore the original state of the unit.						
	2	<ul style="list-style-type: none"> Display freq.: 1270.000MHz Mode: FM 	RF MIX	Pull out connector P2 (from PA-UNIT) and then connect an RF power meter to J3.	Maximum output	RF MIX	C17, C21, C22, C25, C28
	3	<ul style="list-style-type: none"> Display freq.: 1240.000MHz 					R21, R22, R24
4	<ul style="list-style-type: none"> Display freq.: 1240.000MHz 1299.999MHz 	C17, C25					
NOTE: Adjust R21, R22 and R23 for the output powerbalance, it necessary. After adjustment, connect P2 from PA UNIT to J3.							
ALC (a) FM LOW POWER	1	<ul style="list-style-type: none"> Display freq.: 1270.000MHz Mode: FM 	REAR PANEL	Connect an RF power meter to the antenna connector.	Maximum output: more than 12W	PA	C12, C16, C23, C27, C30, C34, C37, C39, C97, C116
	NOTE: Repeat step 5 several times. Make same level of output powers at each frequency (1240.000MHz, 1299.999MHz) by using C40 and C41. Verify the output powers are more than 10.5W at 1240.000MHz and 1299.999MHz. Verify the output power is more than 12W at 1270.000MHz. After adjustment, cut the shorted portion between R174 (D4 side) and ground (at step 1).						
	(b) FM HIGH POWER	2	<ul style="list-style-type: none"> RF POWER: max. counterclockwise 	REAR PANEL	Connect an RF power meter to the antenna connector.	1W	PA
	3	<ul style="list-style-type: none"> Display freq.: 1240.000MHz~1299.999MHz 	R36				
					Same level of output powers at each frequency (the difference is less than 2W)		R13

ADJUSTMENT		ADJUSTMENT CONDITIONS	UNIT	MEASUREMENT LOCATION	VALUE	UNIT	ADJUST
(c) SSB POWER	4	<ul style="list-style-type: none"> Mode: USB MIC GAIN CONTROL: Center Apply AF signal (1.5 KHz/20mV) to MIC connector from an AF oscillator. 	REAR PANEL	Connect an RF power meter to the antenna connector.	8W	MAIN	R82
	5	<ul style="list-style-type: none"> Apply AF signal (1.5kHz/20mV) to MIC connector from an AF oscillator. 			10W		Verify
	(d) CW POWER	6			<ul style="list-style-type: none"> Mode: CW Transmit mode and KEY DOWN 		R63
RF METER	1	<ul style="list-style-type: none"> Display freq.: 1270.000MHz Mode: FM RF POWER CONTROL: max. clockwise 	FRONT PANEL	RF voltmeter	80% of full scale deflection	MAIN	R240
CARRIER BALANCE	1	<ul style="list-style-type: none"> Display freq.: 1299.999MHz Mode: USB or LSB Measure the output voltage at each mode (USB, LSB). RF POWER CONTROL: max. clockwise 	REAR PANEL	Connect an RF voltmeter to the antenna connector.	Minimum output voltage.	MAIN	R72, R75
FM DEVIATION	1	<ul style="list-style-type: none"> Display freq.: 1270.000MHz Mode: FM MIC GAIN CONTROL: Center Apply AF input (1 KHz/2mV) to the MIC CONNECTOR 	IF	Connect an oscilloscope to J4.	Symmetrical response about the horizontal base line.	MAIN	R18
	2	<ul style="list-style-type: none"> Increase AF input by 20dB. (1 KHz/20mV) 		Connect a deviation meter to J4.	$\pm 4.8\text{kHz}$		R29
	3	<ul style="list-style-type: none"> Decrease AF input by 20dB. (1 KHz/2mV) 			$\pm 3.5\text{kHz} \sim \pm 4.5\text{kHz}$		Verify
TONE DEVIATION (#03 Only)	1	<ul style="list-style-type: none"> Display freq.: 1270.000MHz Mode: FM SUBAUDIBLE TONE SWITCH: ON TONE SELECT SWITCH: Set to ON position and select TONE No. 08 by using TUNING CONTROL. Mic input: none Transmit 	IF	Connect a deviation meter to J4.	0.6kHz~0.65kHz	LOGIC	R57
TONE DEVIATION (#02 Only)	1	<ul style="list-style-type: none"> Display freq.: 1270.000MHz Mode: FM TONE SWITCH: ON Mic input: none Transmit 	IF	Connect a deviation meter to J4.	3.5kHz/DEV.	DC-DC	R4

UNIT LOCATIONS

(BOTTOM VIEW)

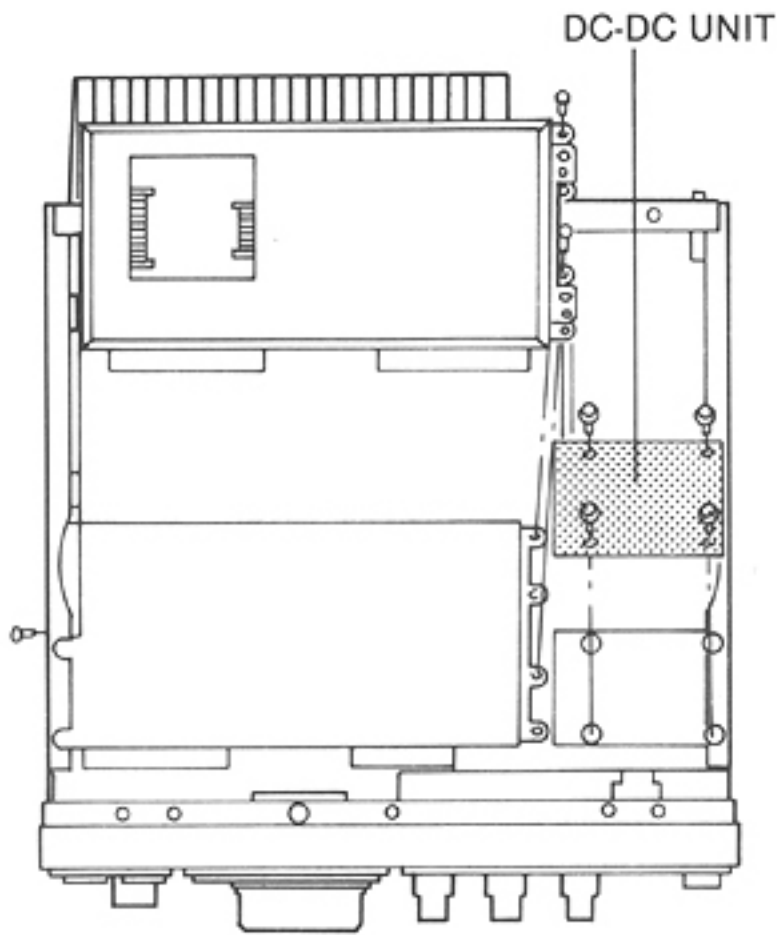

(TOP VIEW)

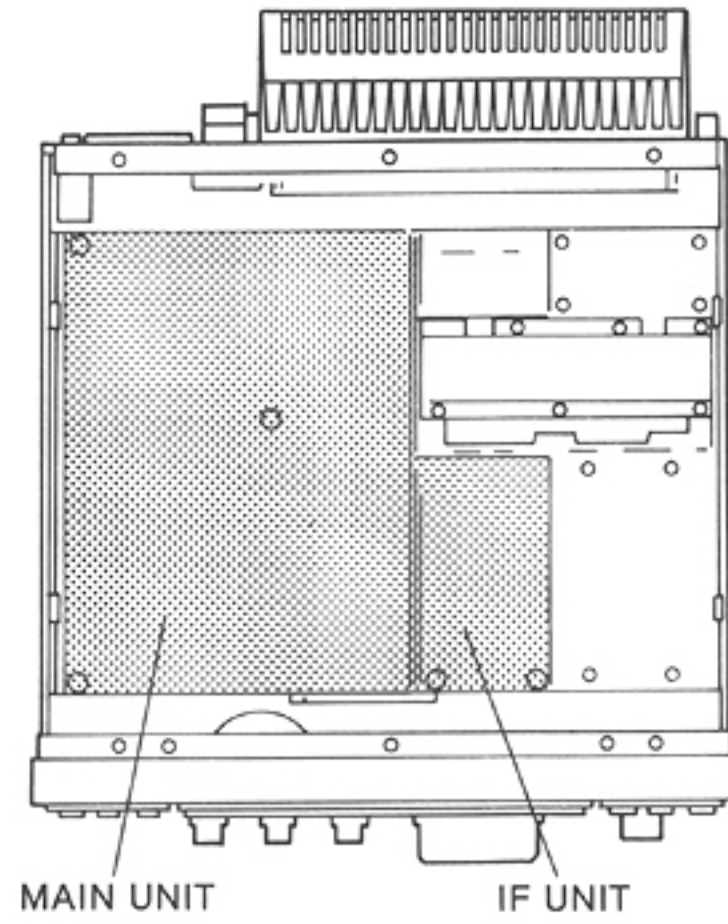

IF UNIT

J4 C.P. (RF VOLTmeter/
OSCILLOSCOPE/
FM DEVIATION
METER)

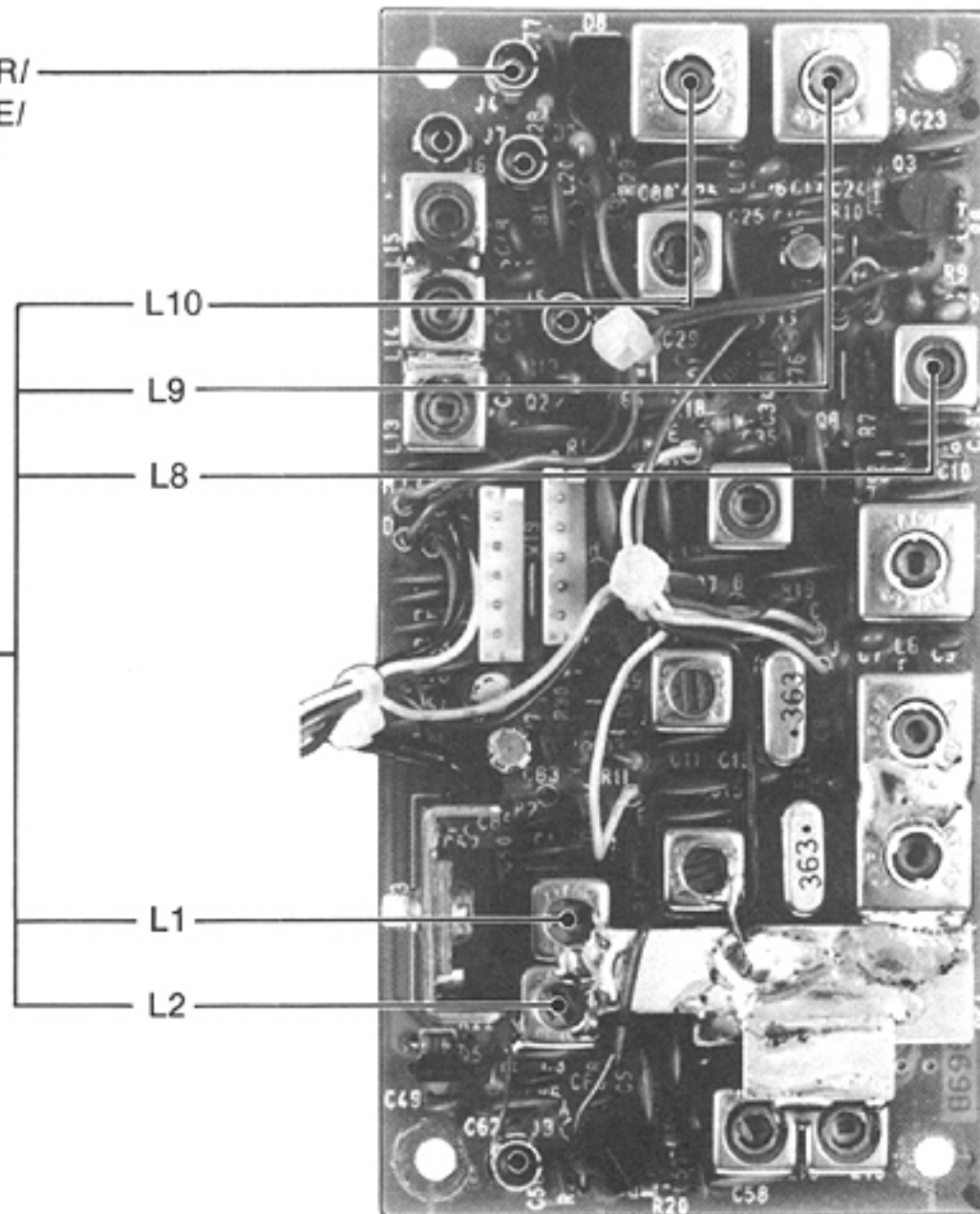

**DC-DC UNIT
(#02 Only)**

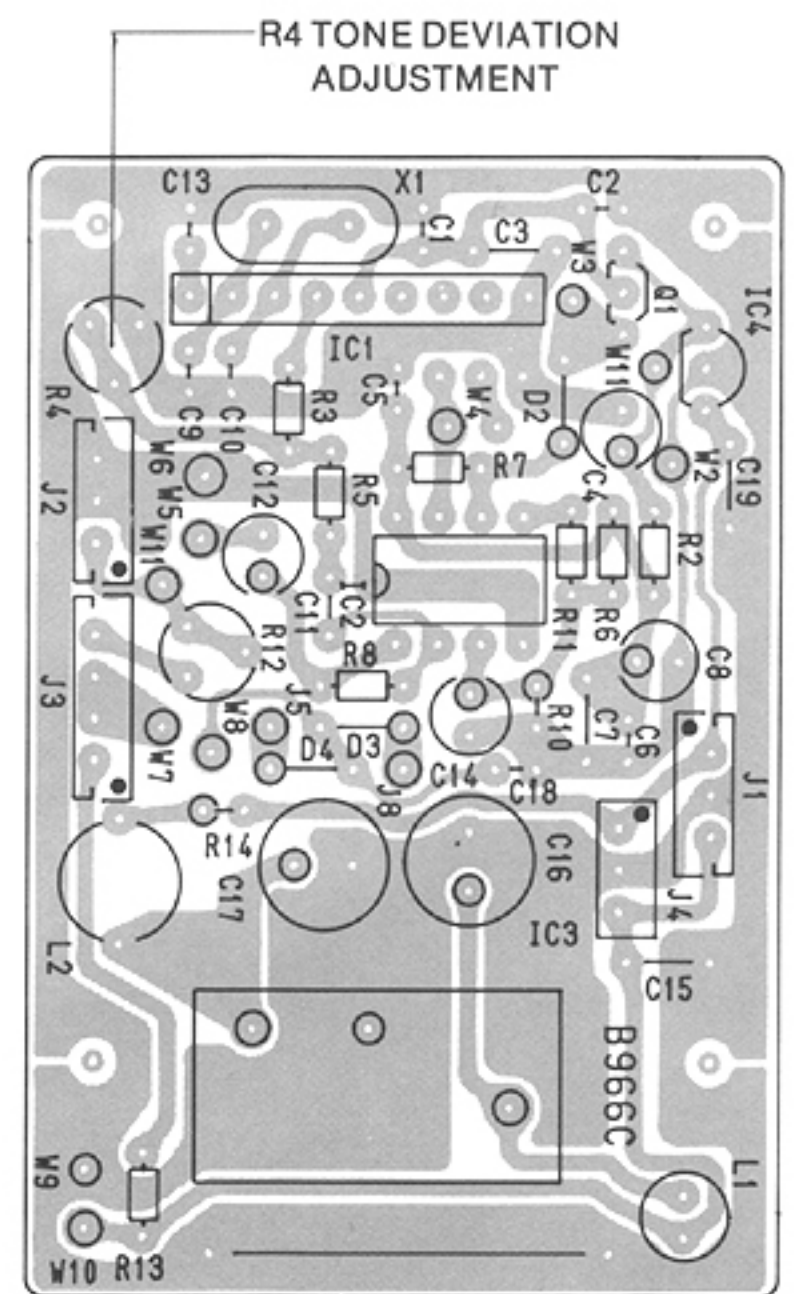

* C.P.: Check Point

MAIN UNIT

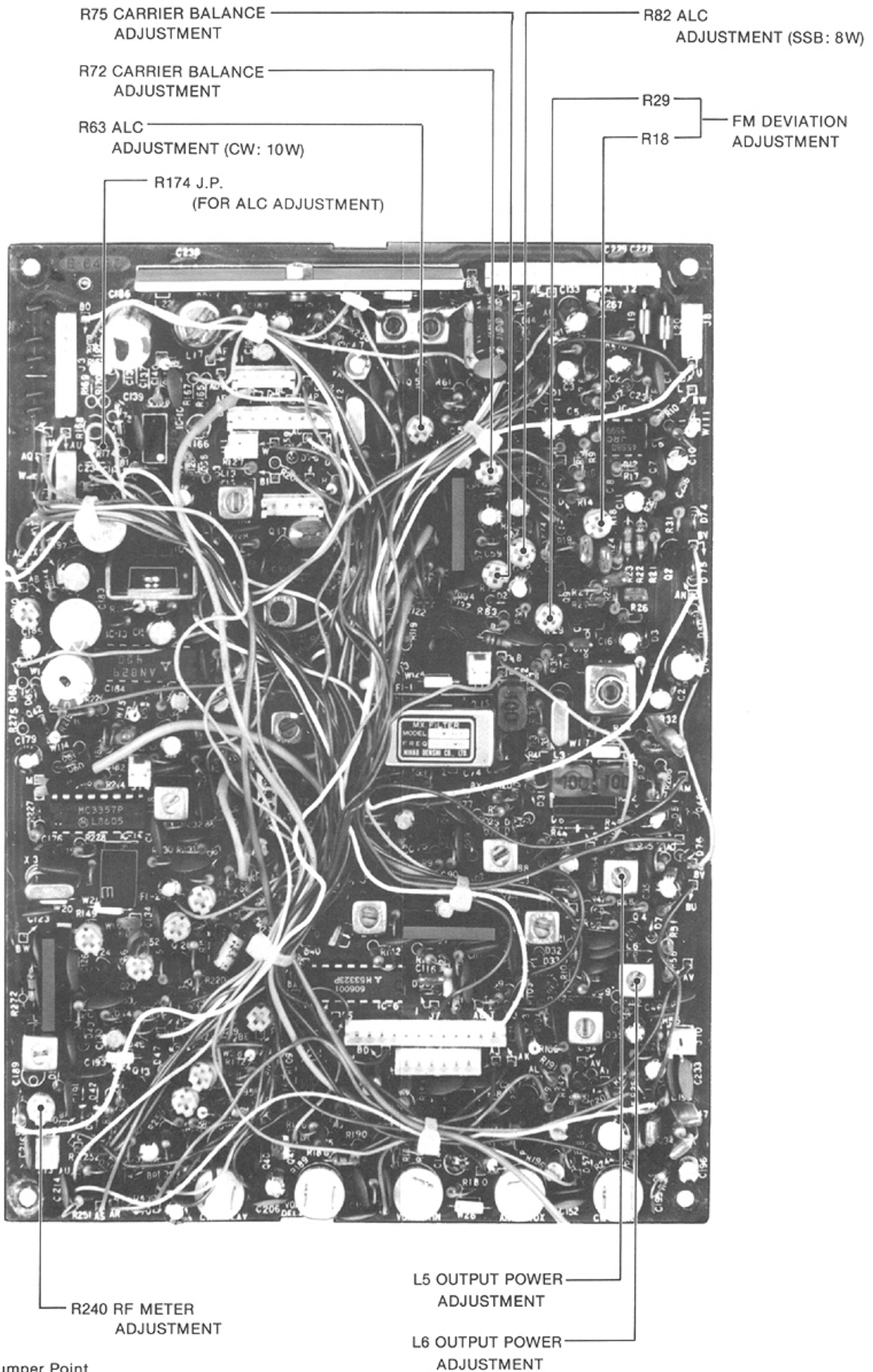

* J.P.: Jumper Point

UNIT LOCATIONS

(BOTTOM VIEW)

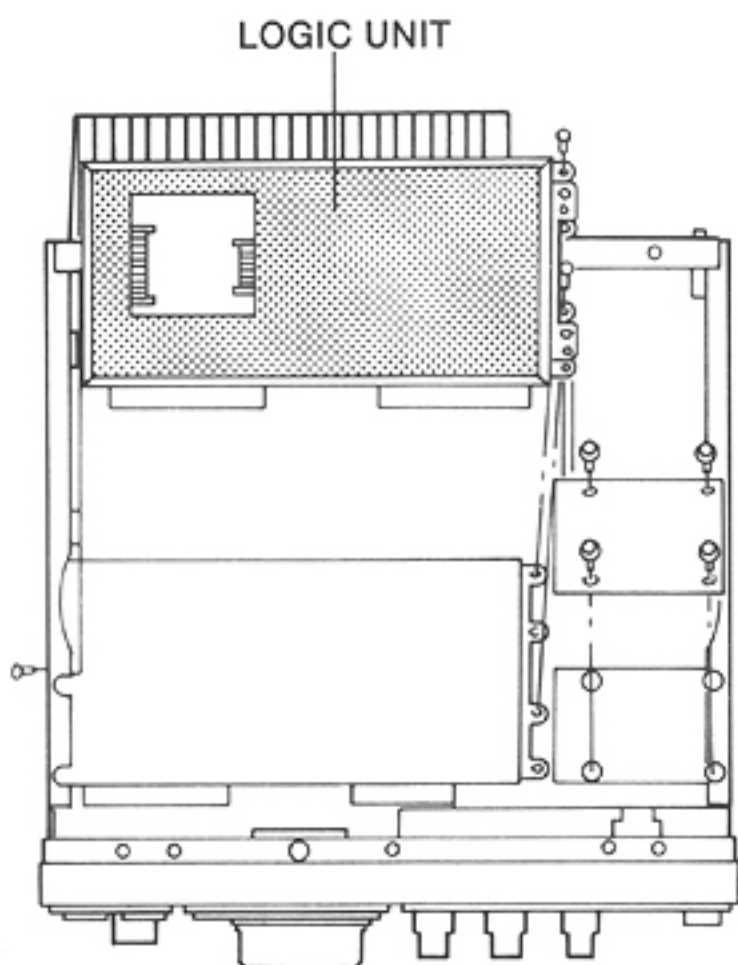

(TOP VIEW)

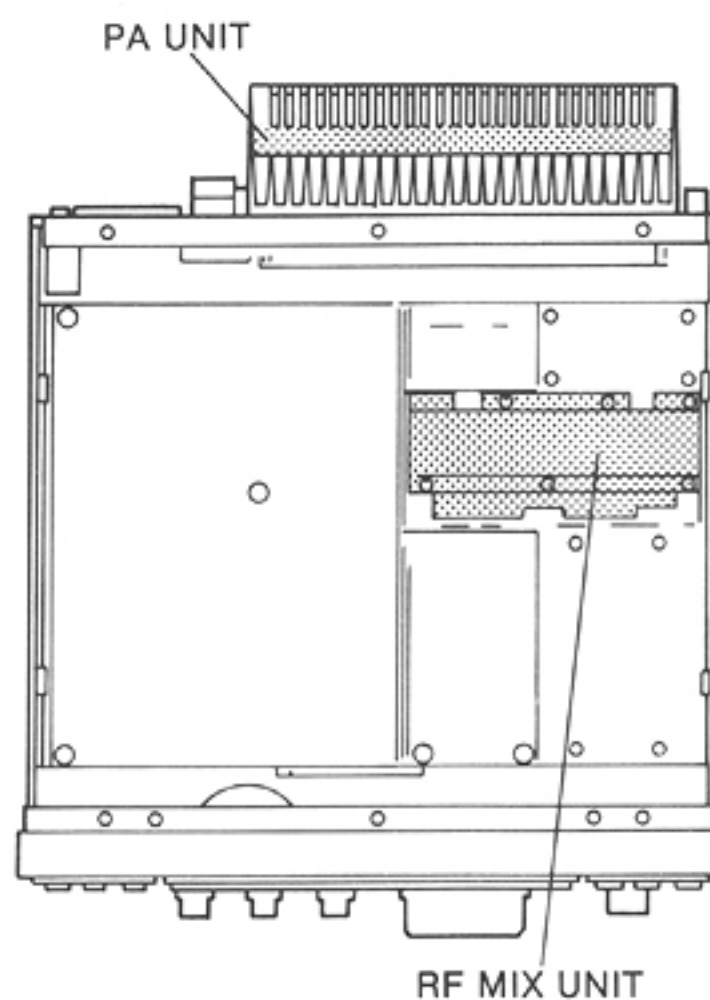

**LOGIC UNIT
(#03 Only)**

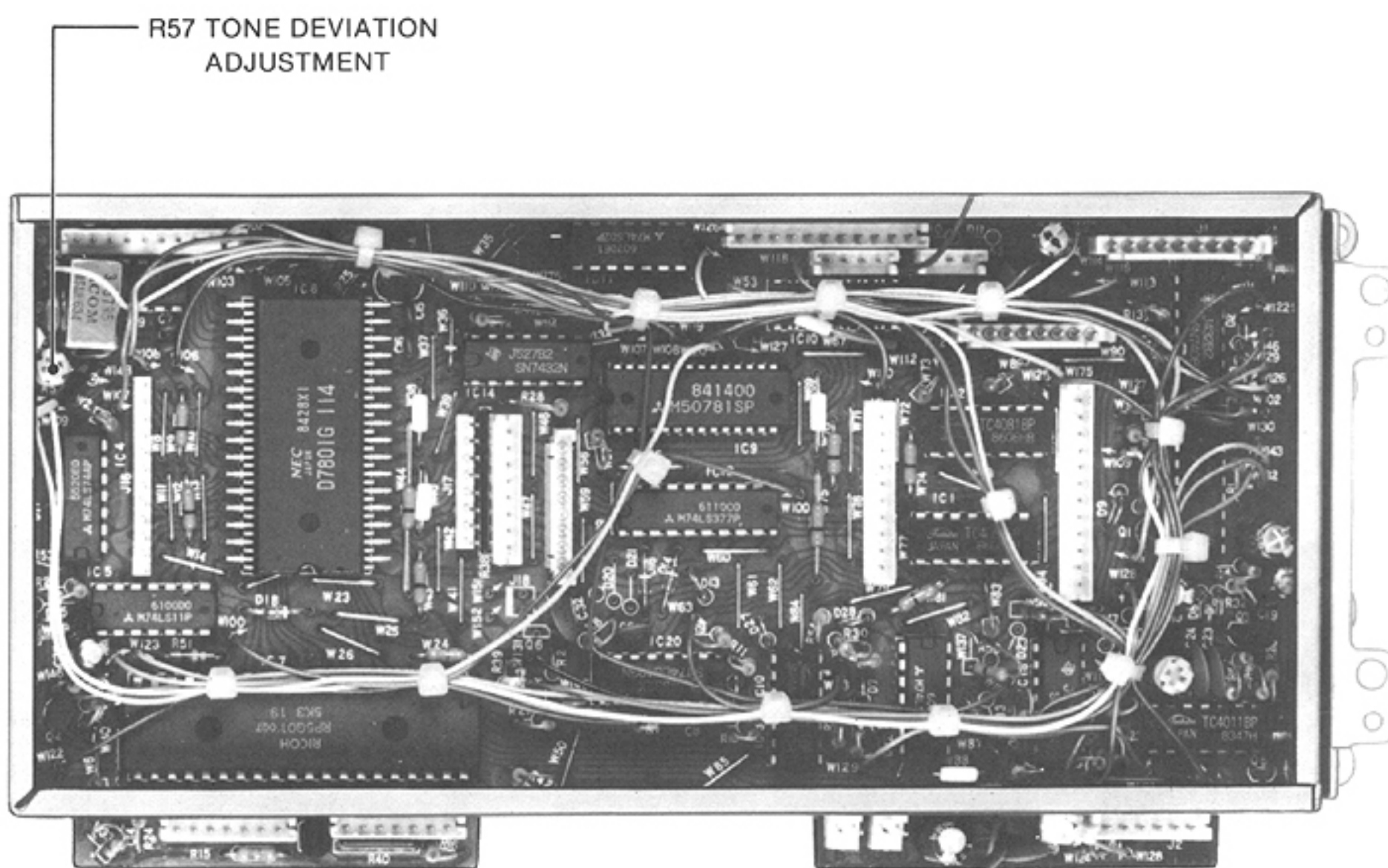

RF MIX UNIT

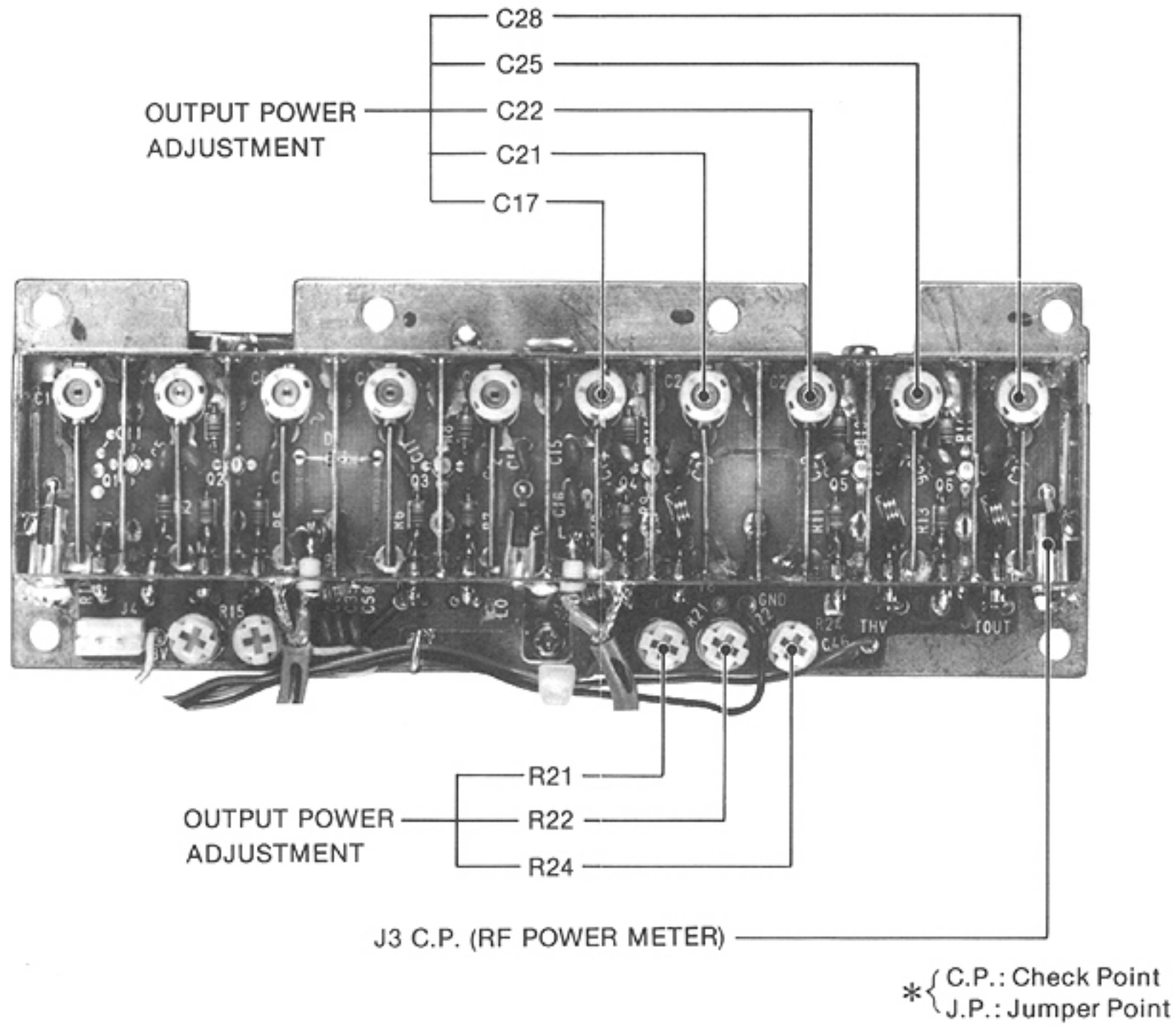

PA UNIT (Transistor-type)

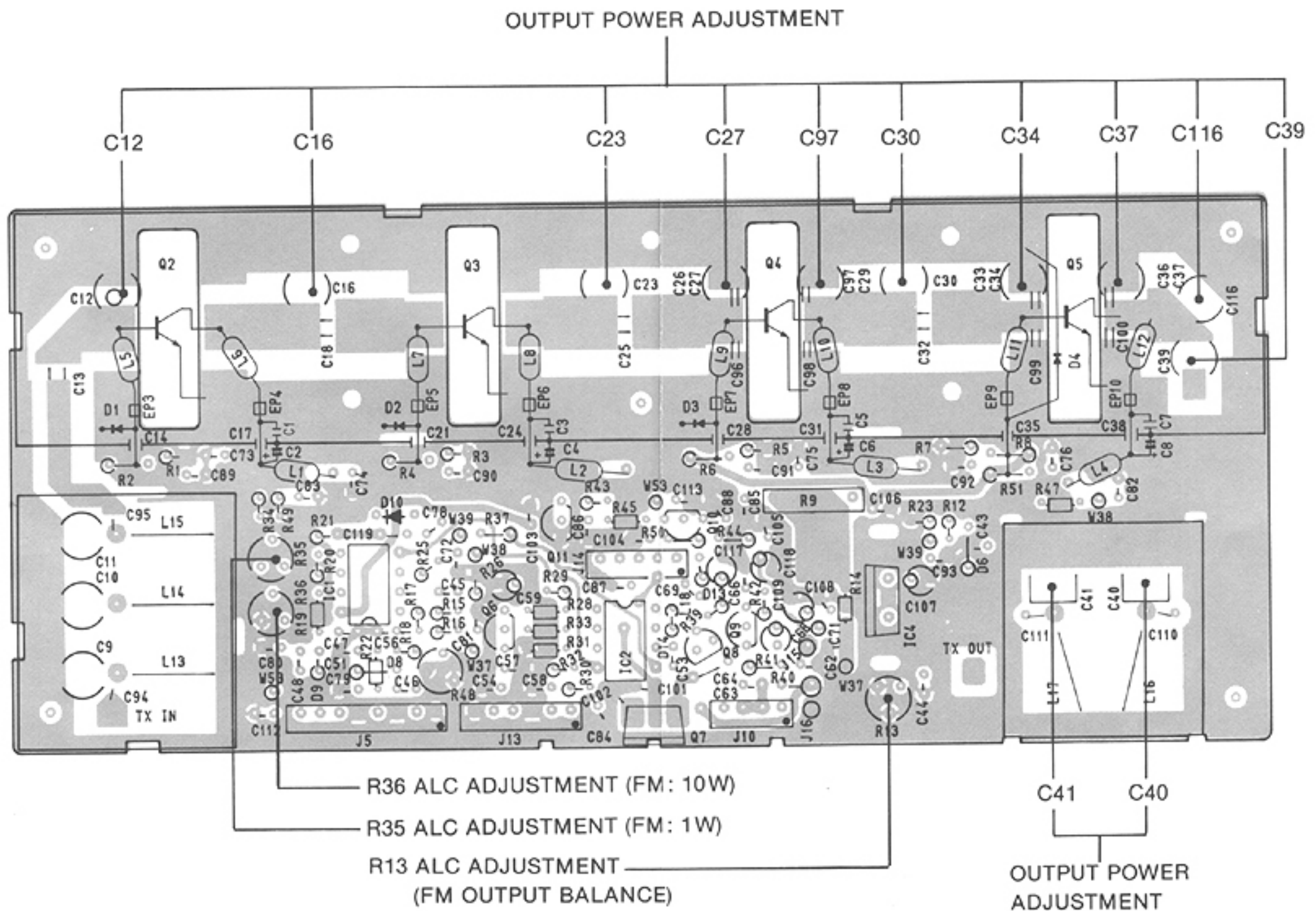

SECTION 7 VOLTAGE/CIRCUIT DIAGRAMS

7-1 FRONT UNIT, VR UNIT, AND MIC UNIT

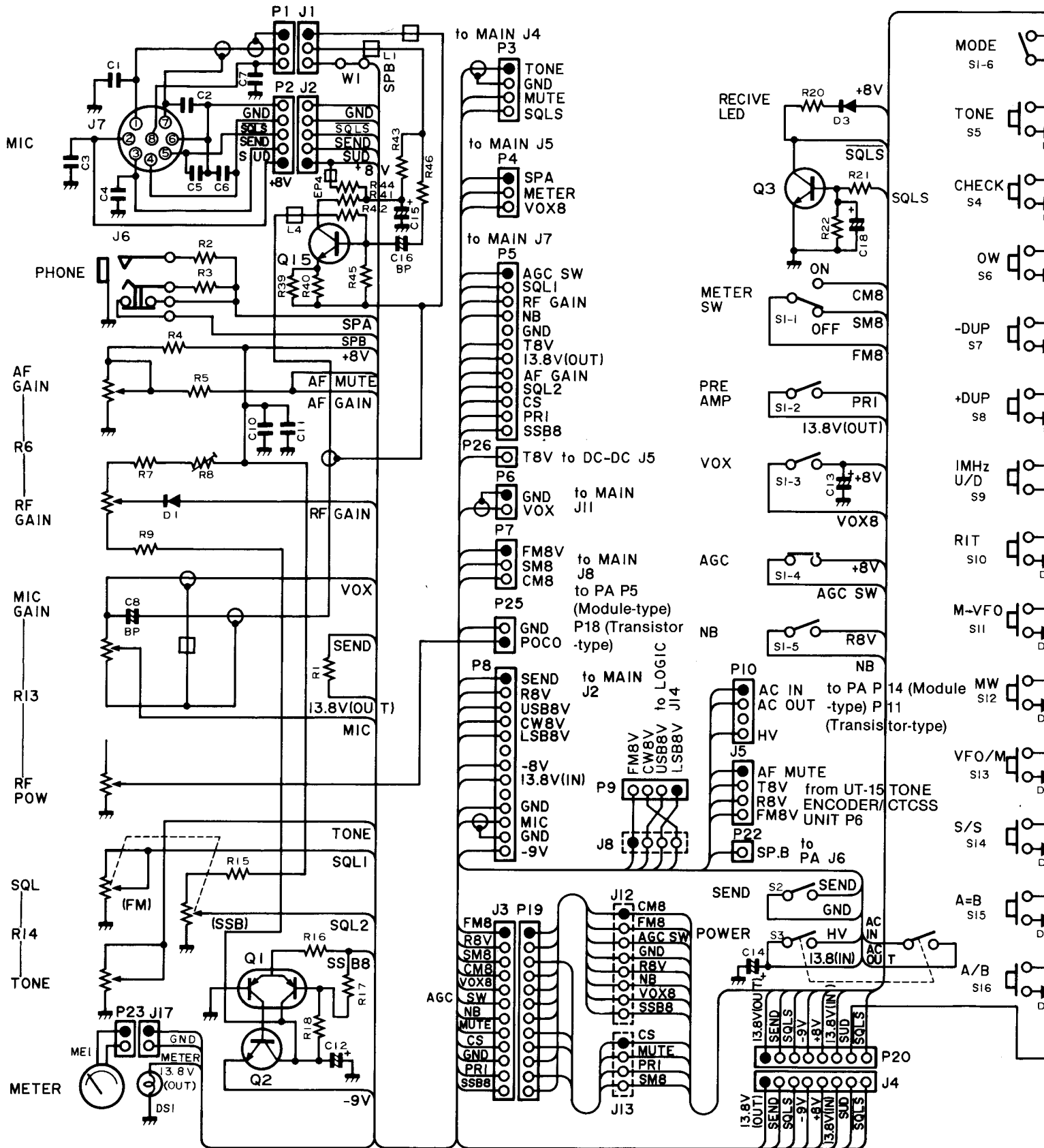

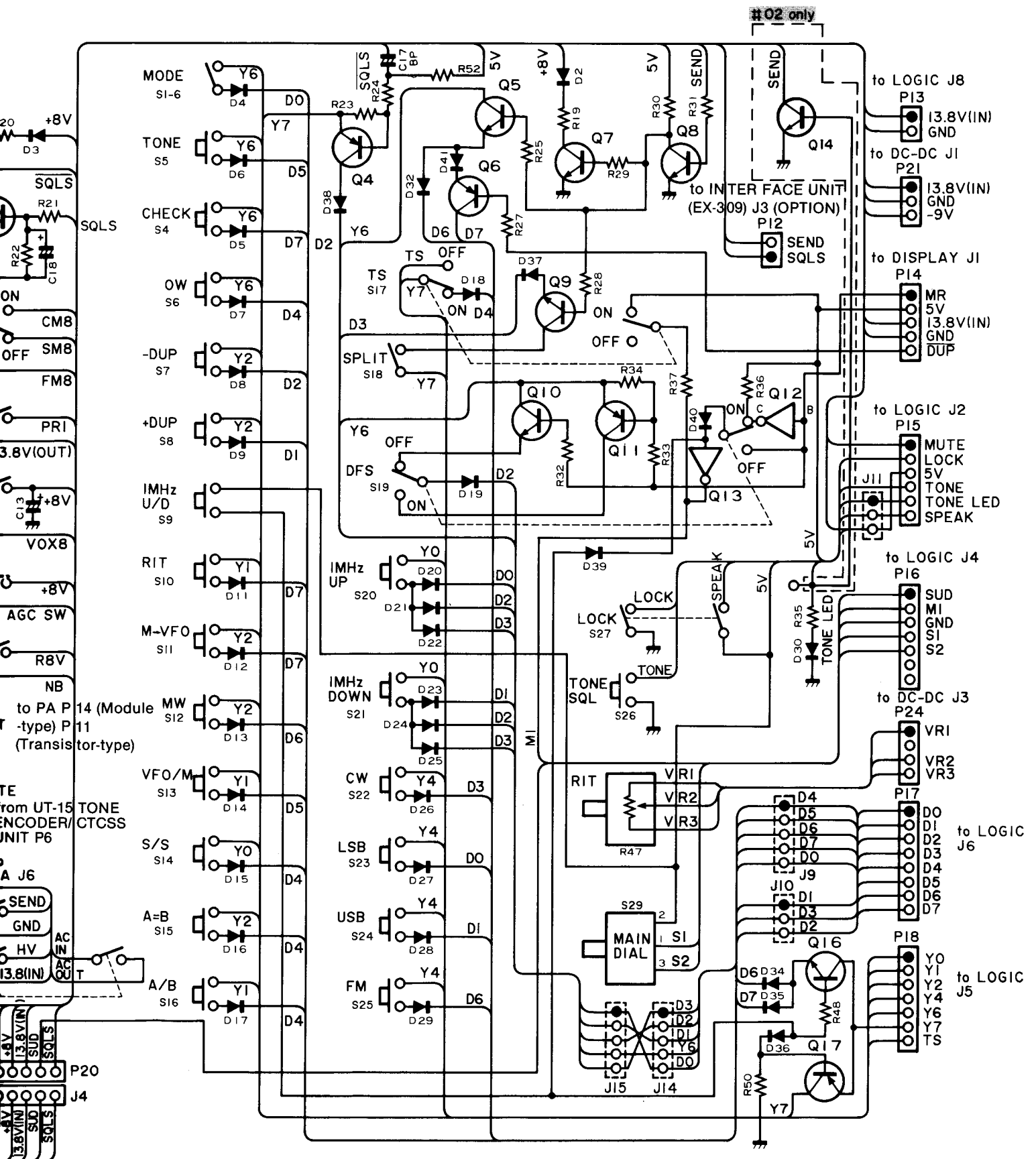

7-2 DISPLAY UNIT

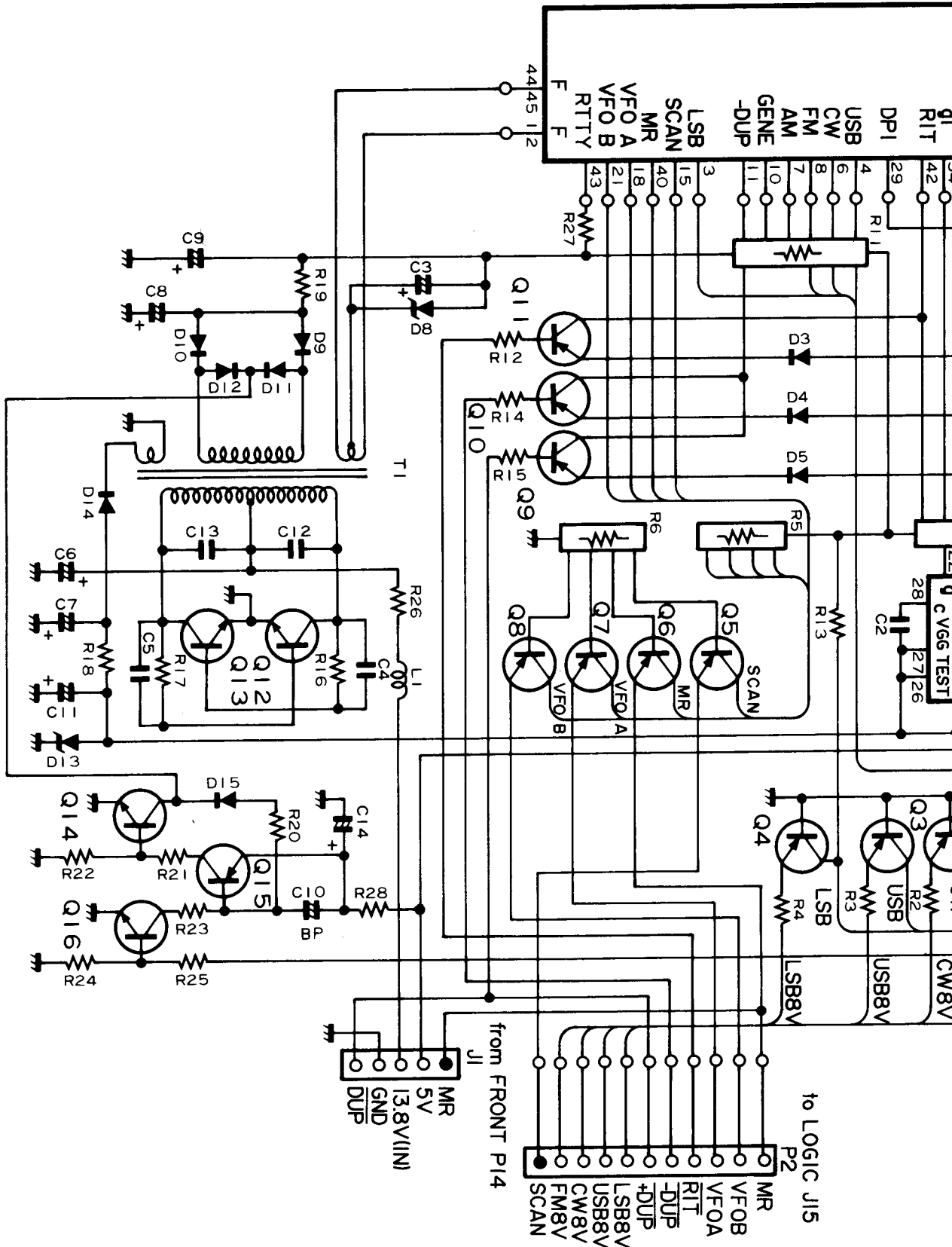

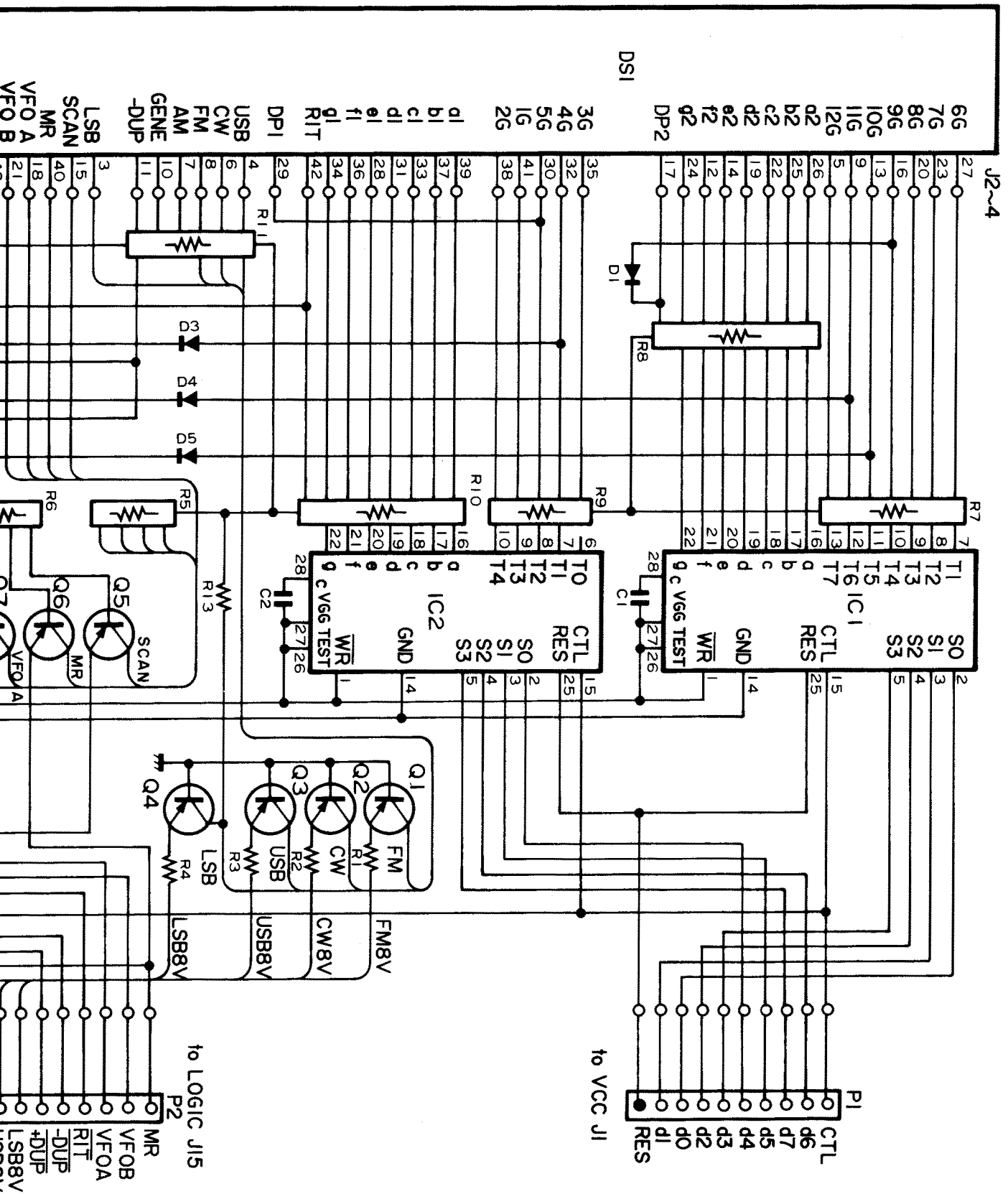

7-3 MAIN UNIT

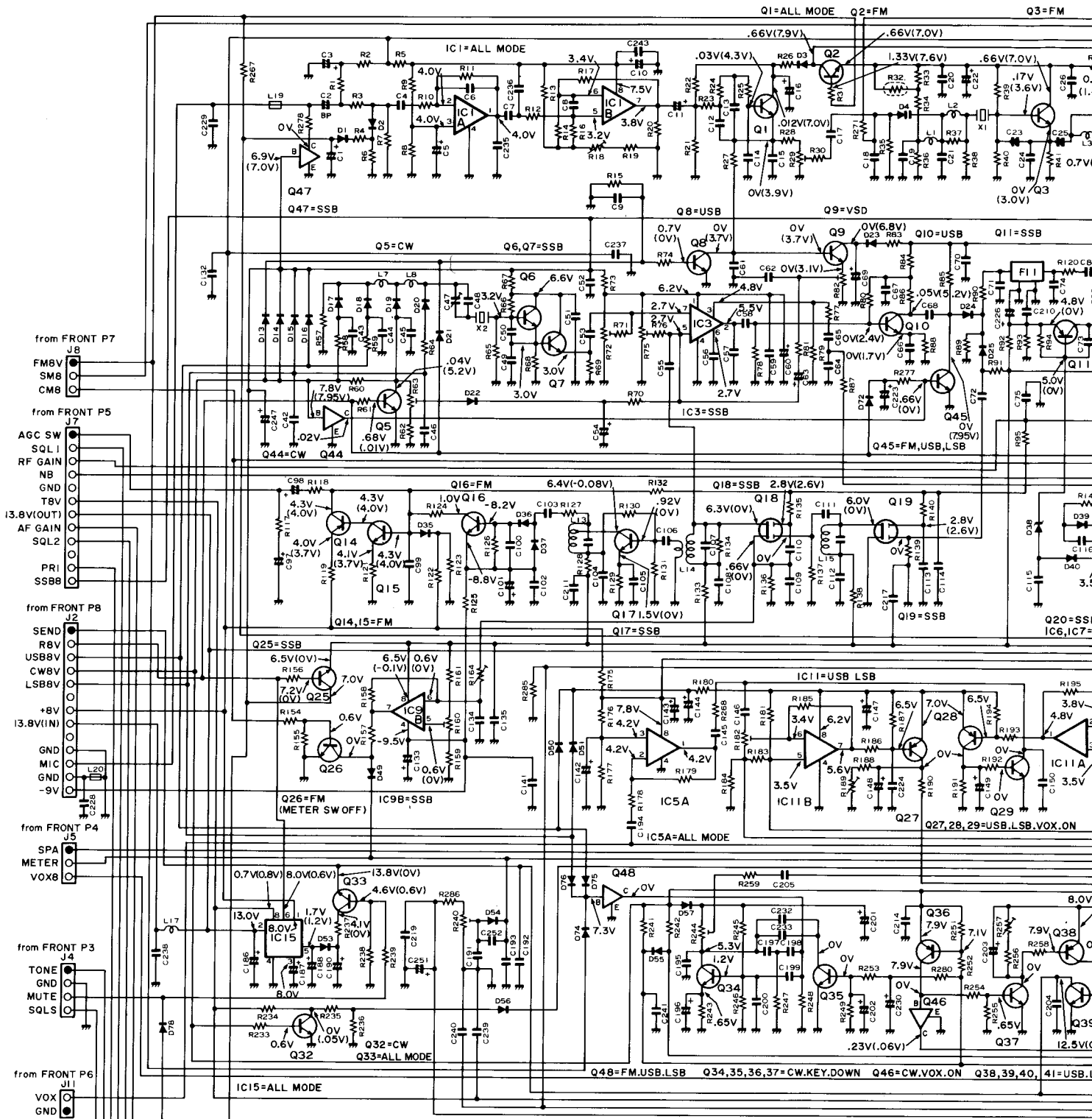

MEASUREMENT CONDITIONS

- VOLTMETER: 50k OHMS/V 0.3, 3, 12, 60V Range
- All voltage values shown in circuitry are DC voltage in Transmit and Receive mode
- () Voltage values at Transmit

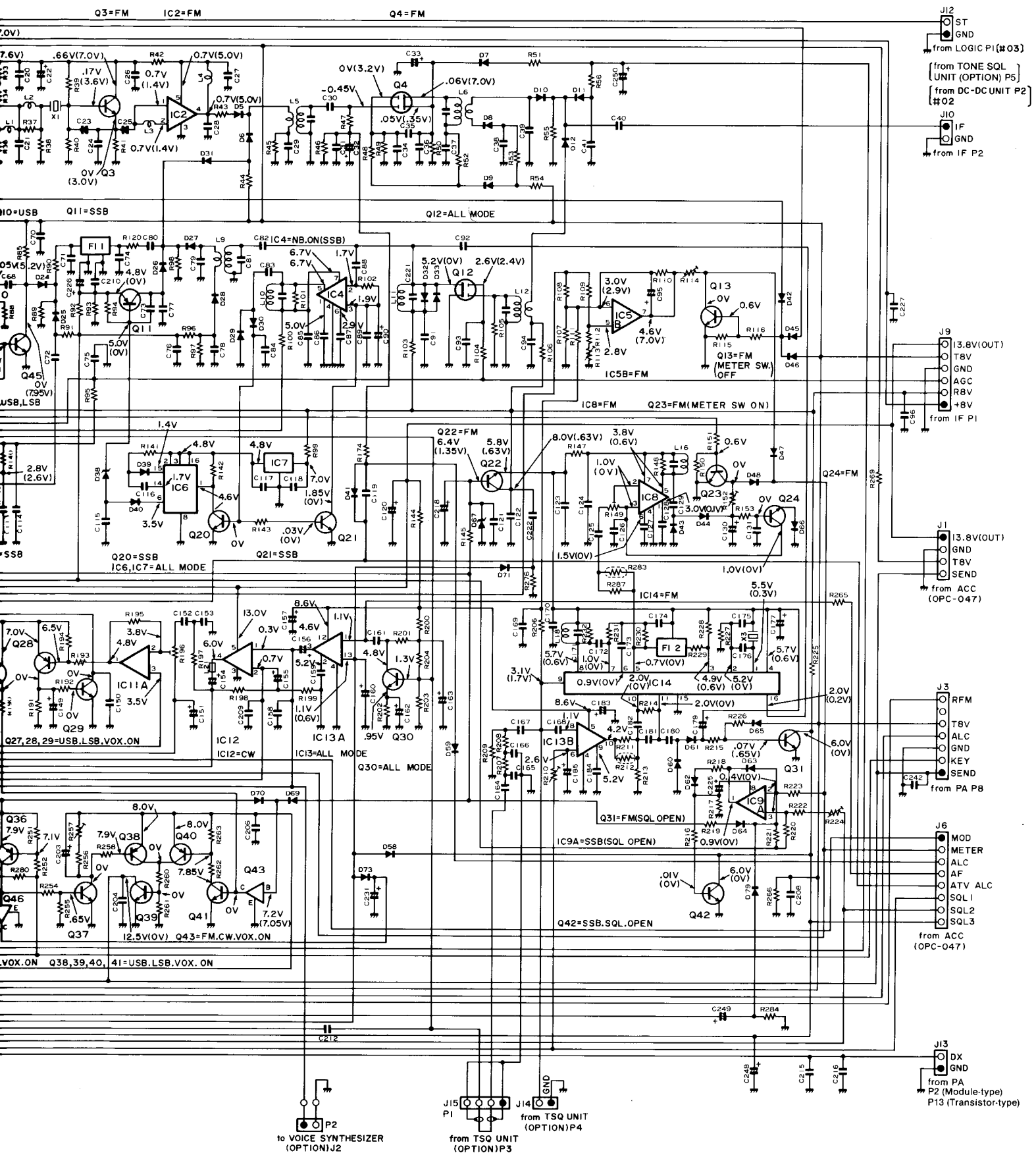

7-4 PLL UNIT AND DOUBLER UNIT

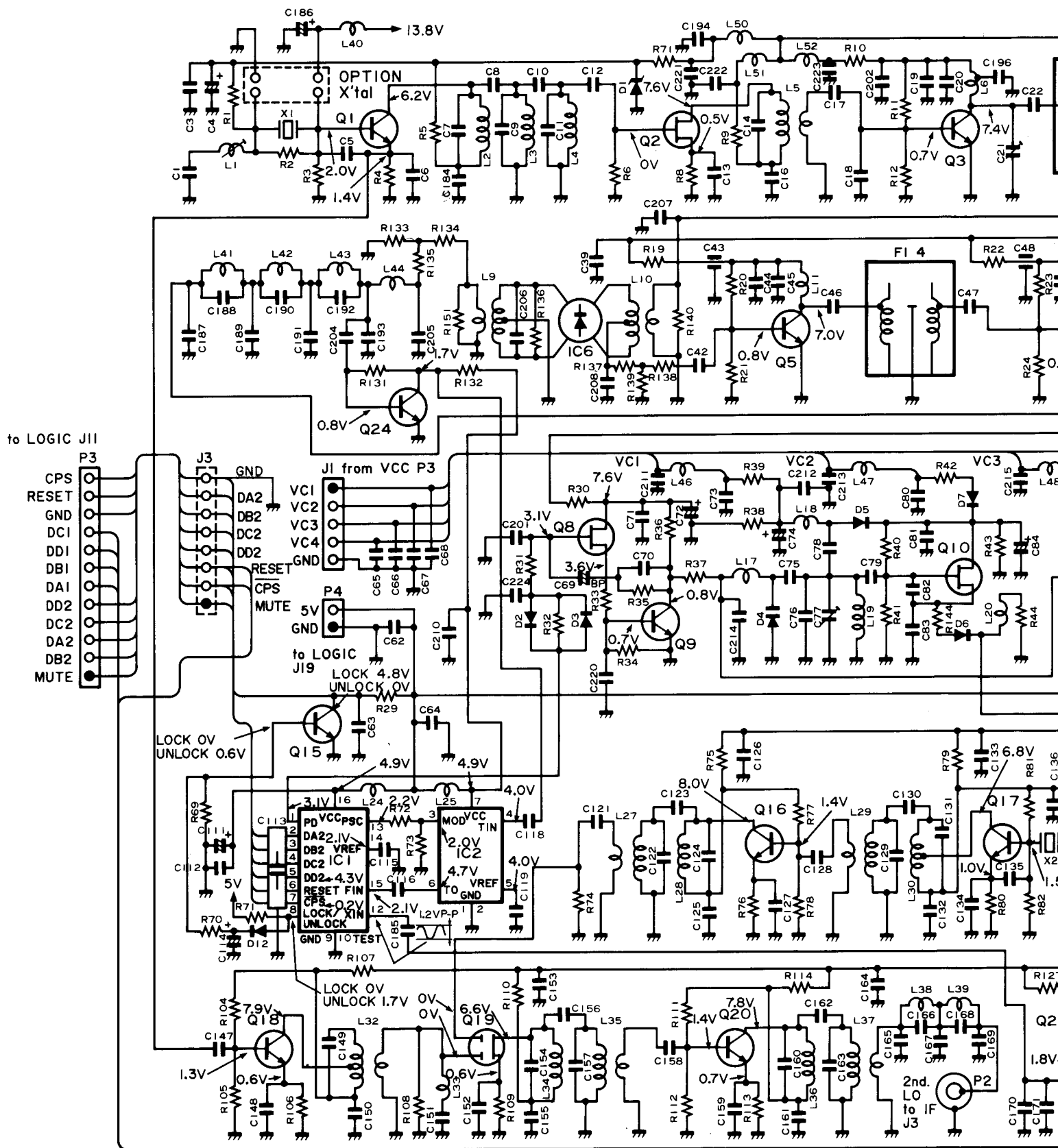

MEASUREMENT CONDITIONS

- VOLTMETER: 50k OHMS/V
- TRANSMIT AND RECEIVE MODE: FM1270 MHz

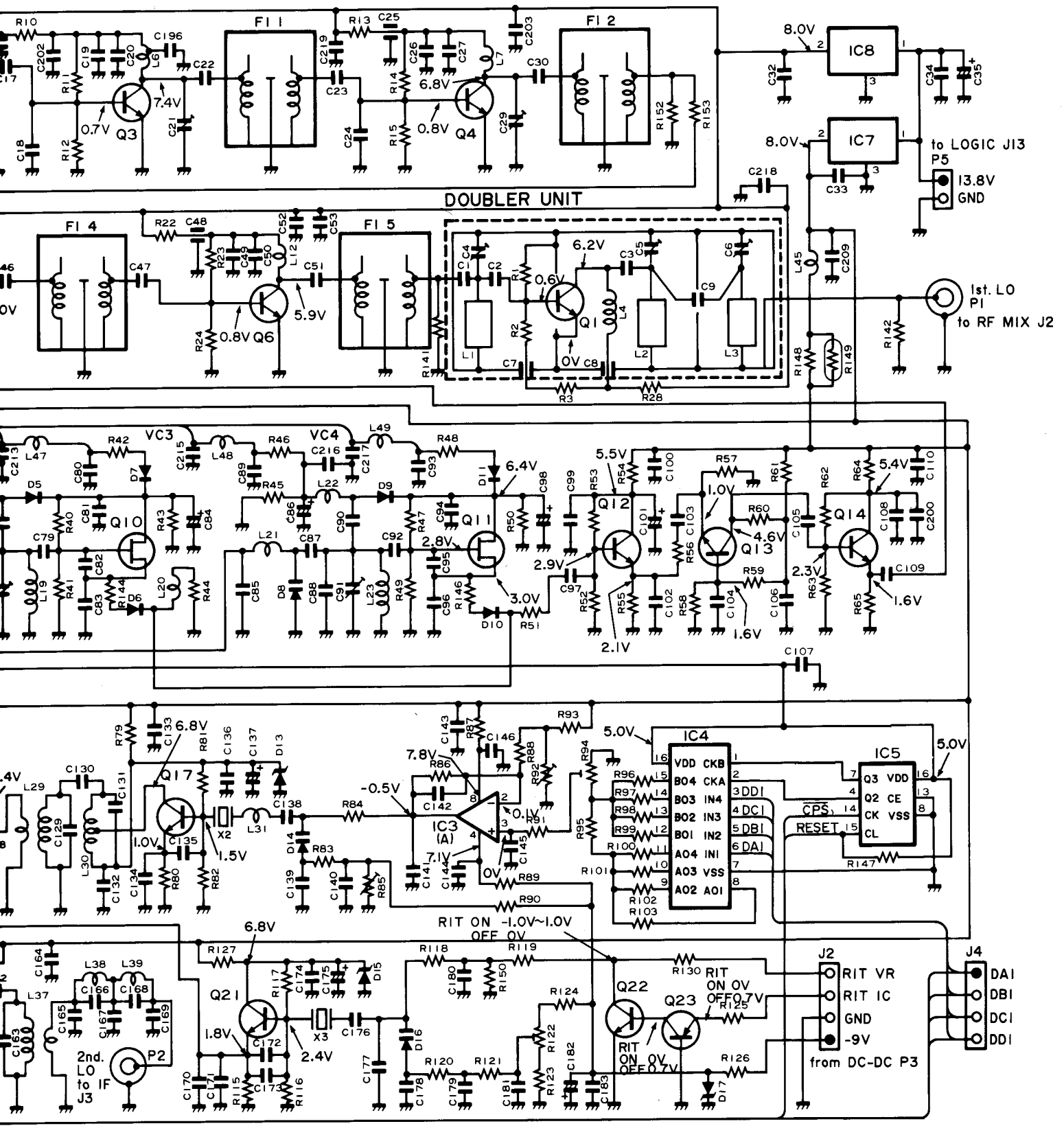

7-5 LOGIC UNIT (#02)

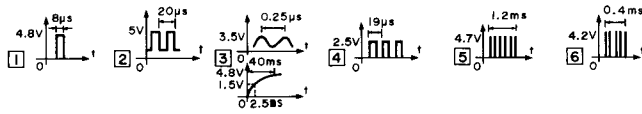

from UT15
TONE ENCODER/IC TSS UNIT P6
from DC-DC PIEUROPE TONE)

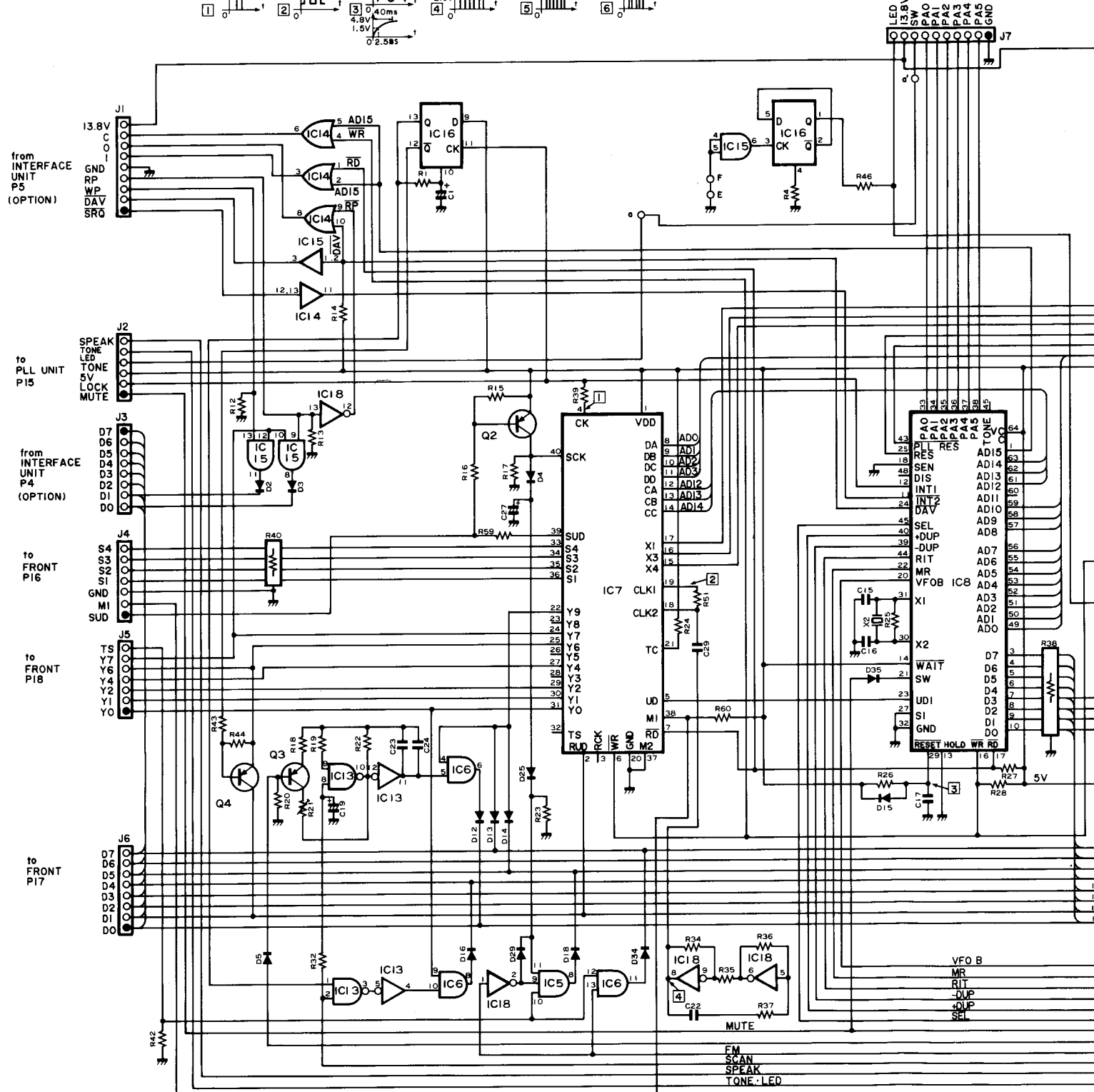

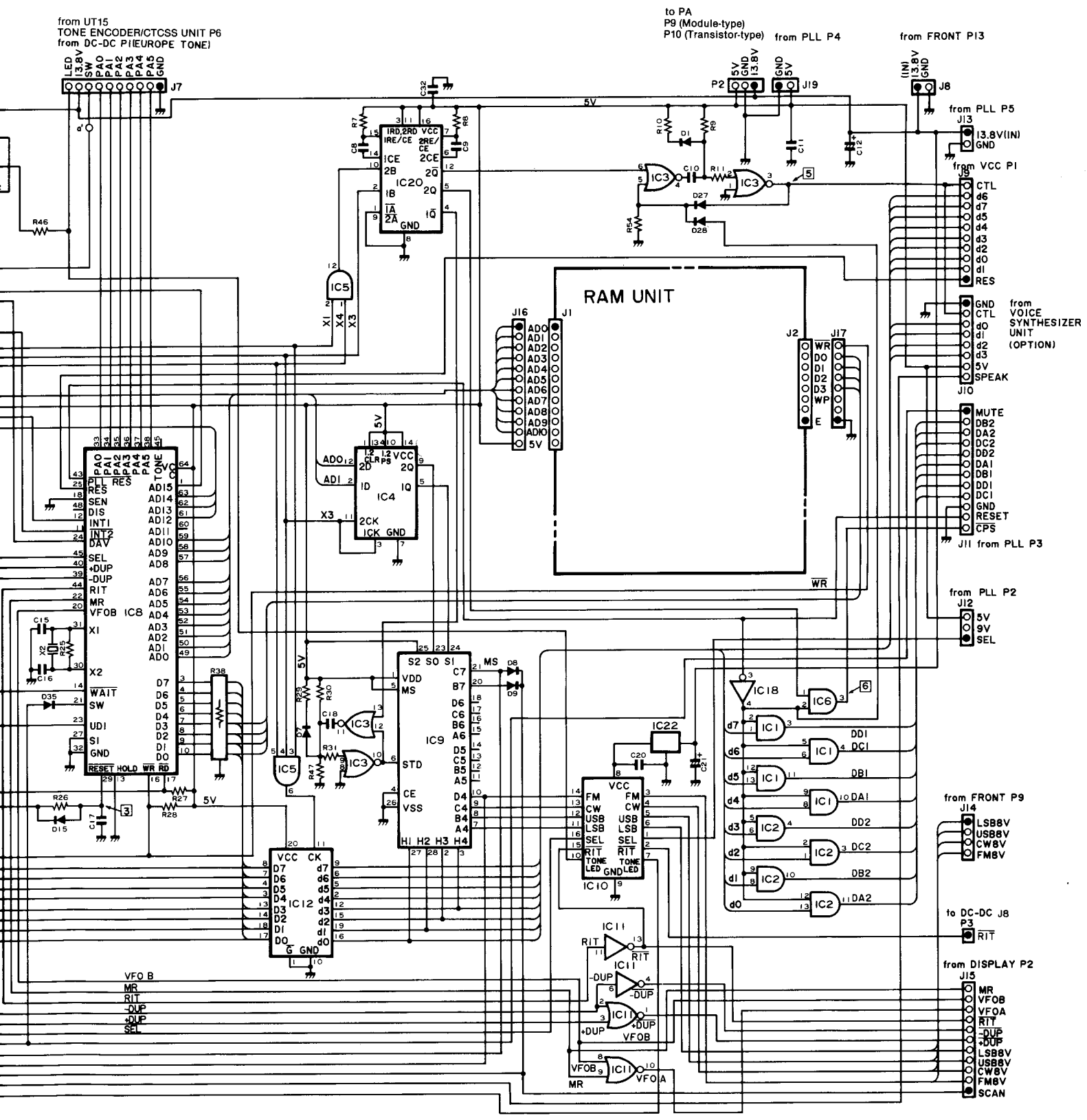

7-5 LOGIC UNIT (#03, #04)

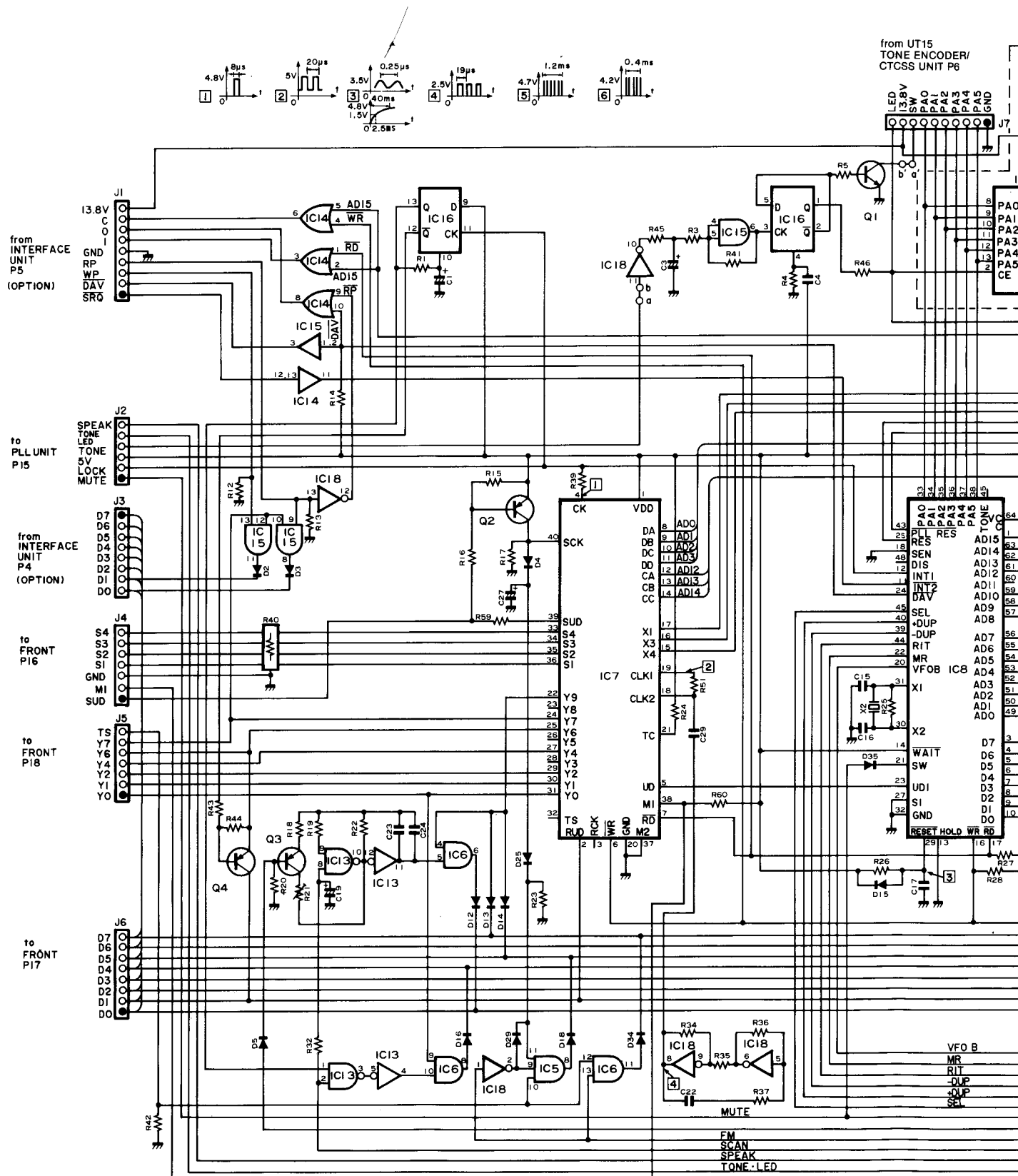

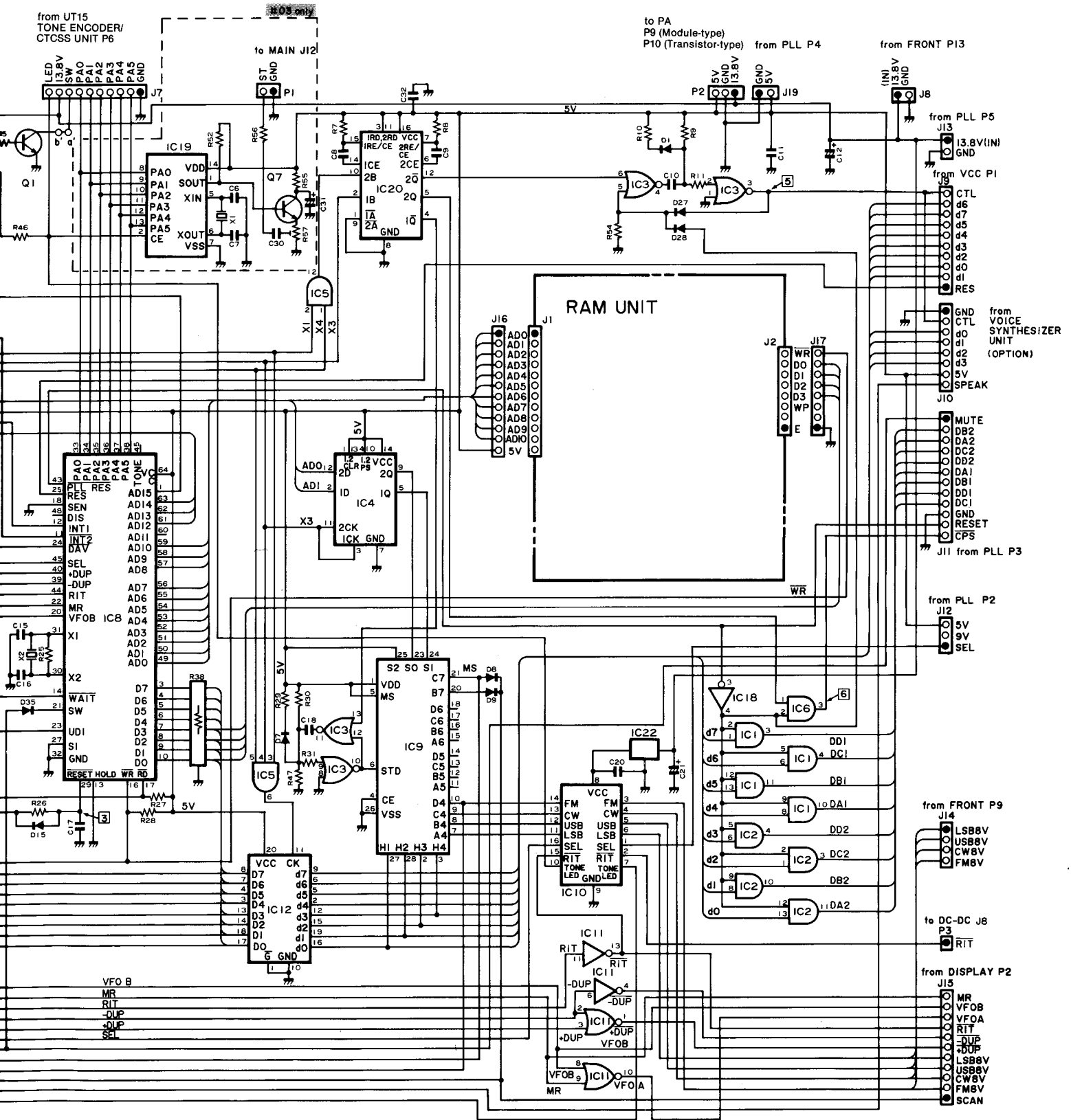

DC-DC UNIT

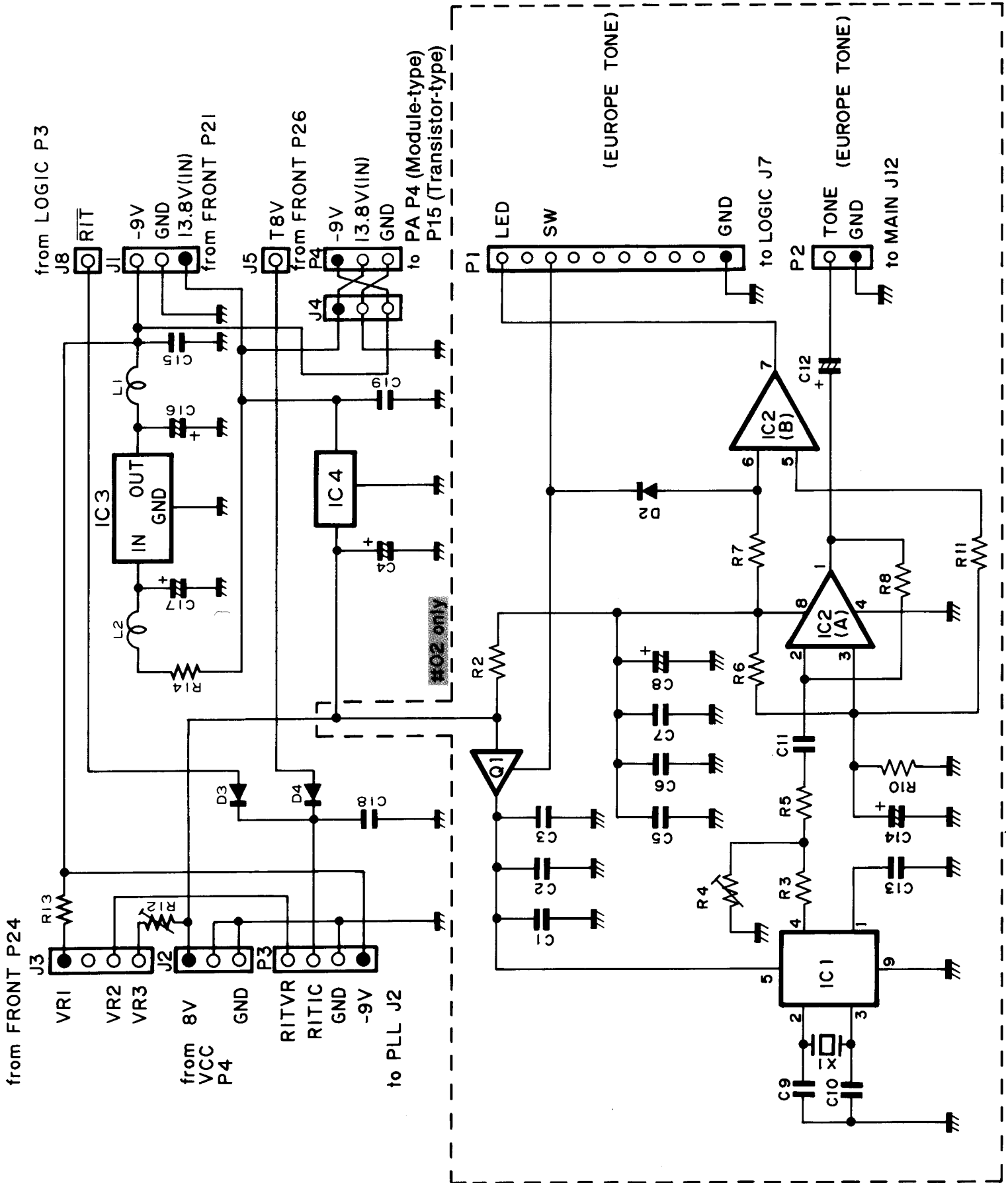

7-7 IF UNIT

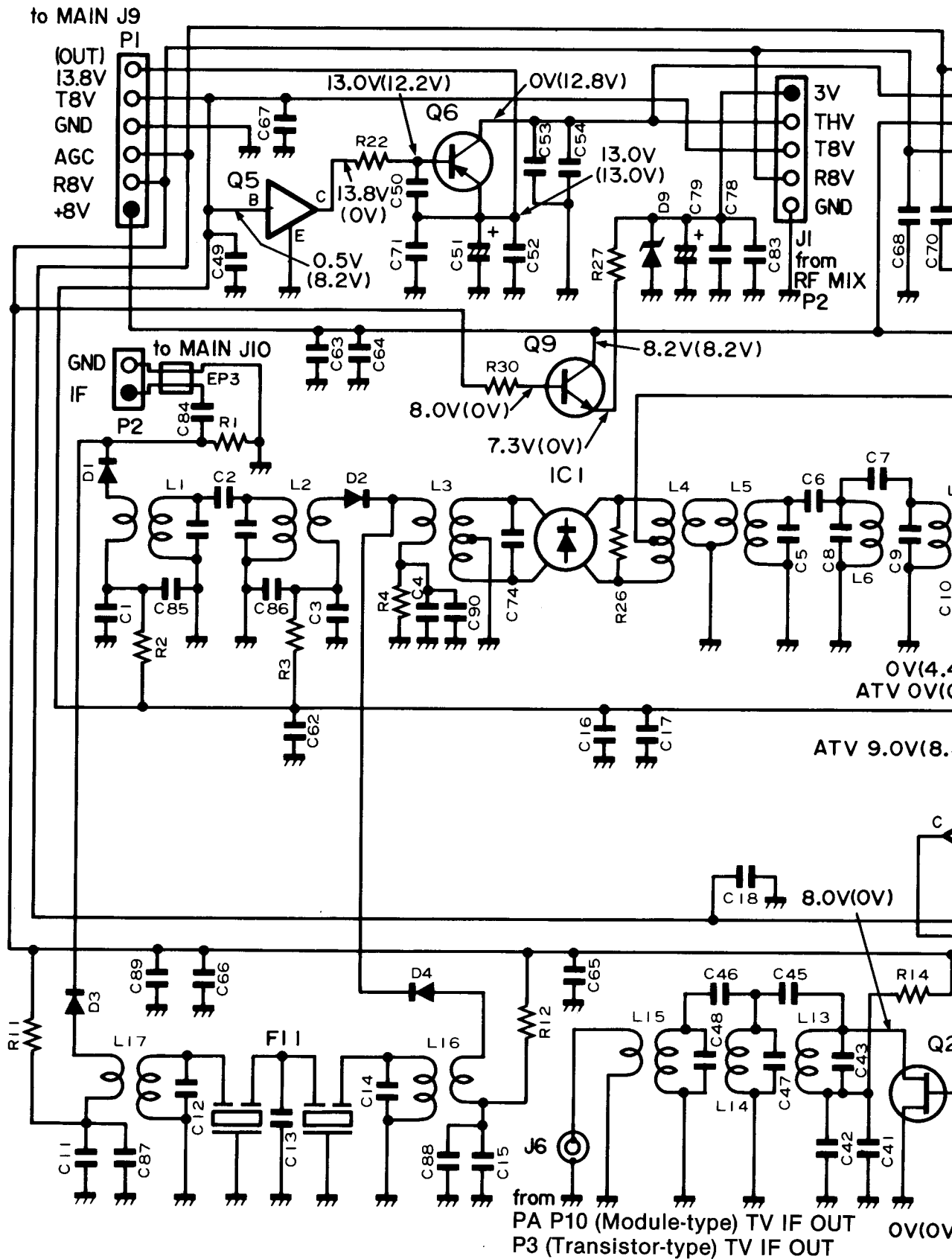

MEASUREMENT CONDITIONS

- VOLTMETER: 50K OHMS/V
- No signal
- () Voltage values at Transmit

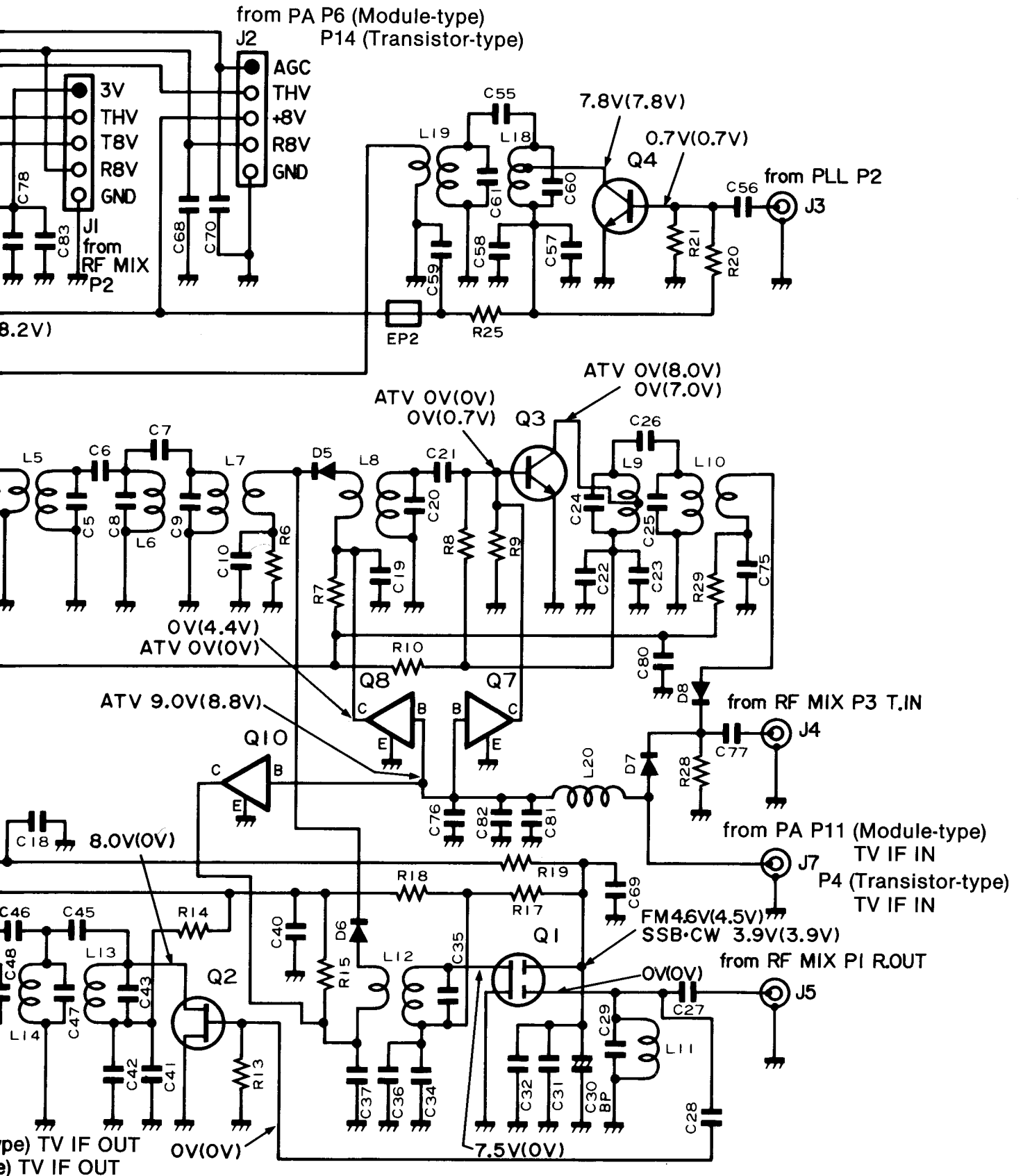

7-8 FILTER UNIT AND RF MIX UNIT

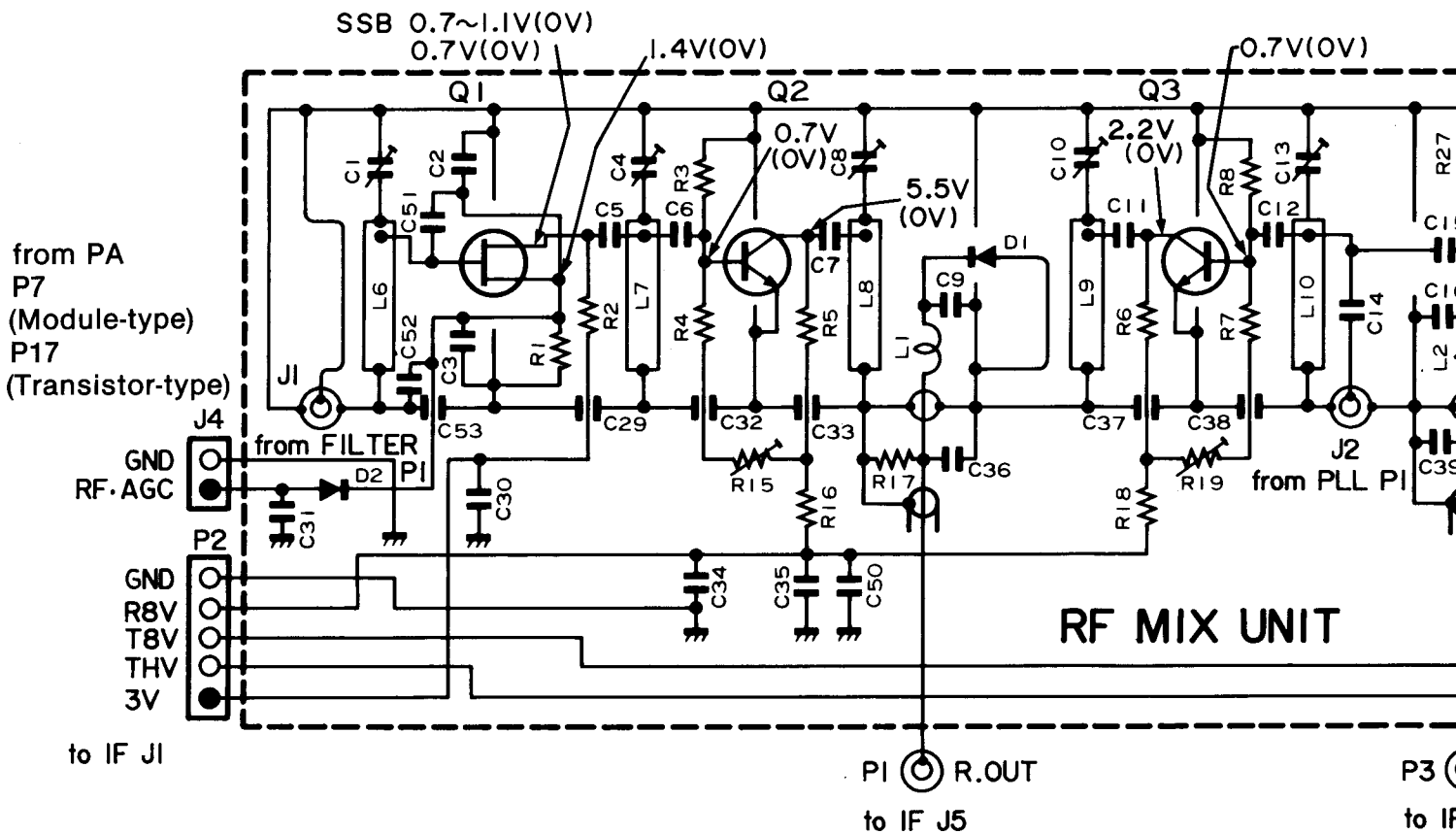
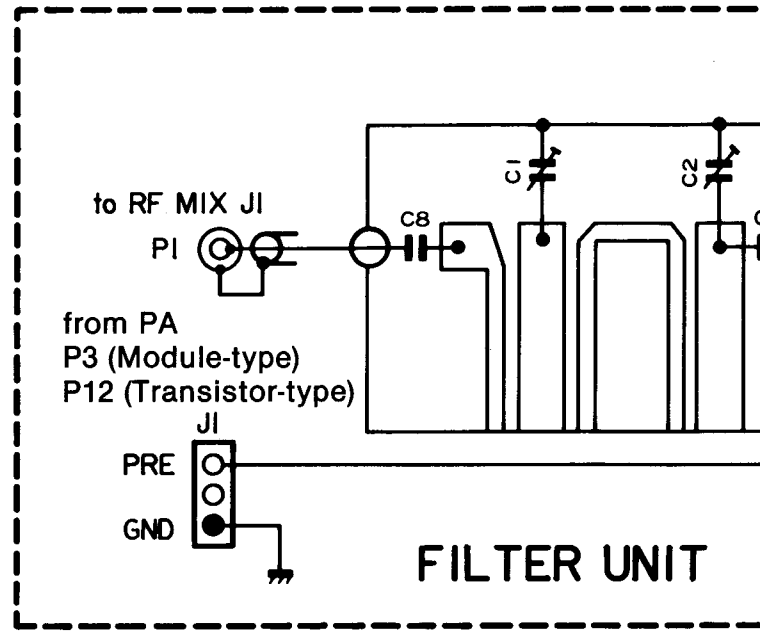

MEASUREMENT CONDITIONS

- VOLTMETER: 50k OHMS/V
- No signal
- TRANSMIT AND RECEIVE MODE: FM 1270MHz
- ()..... Voltage values at Transmit

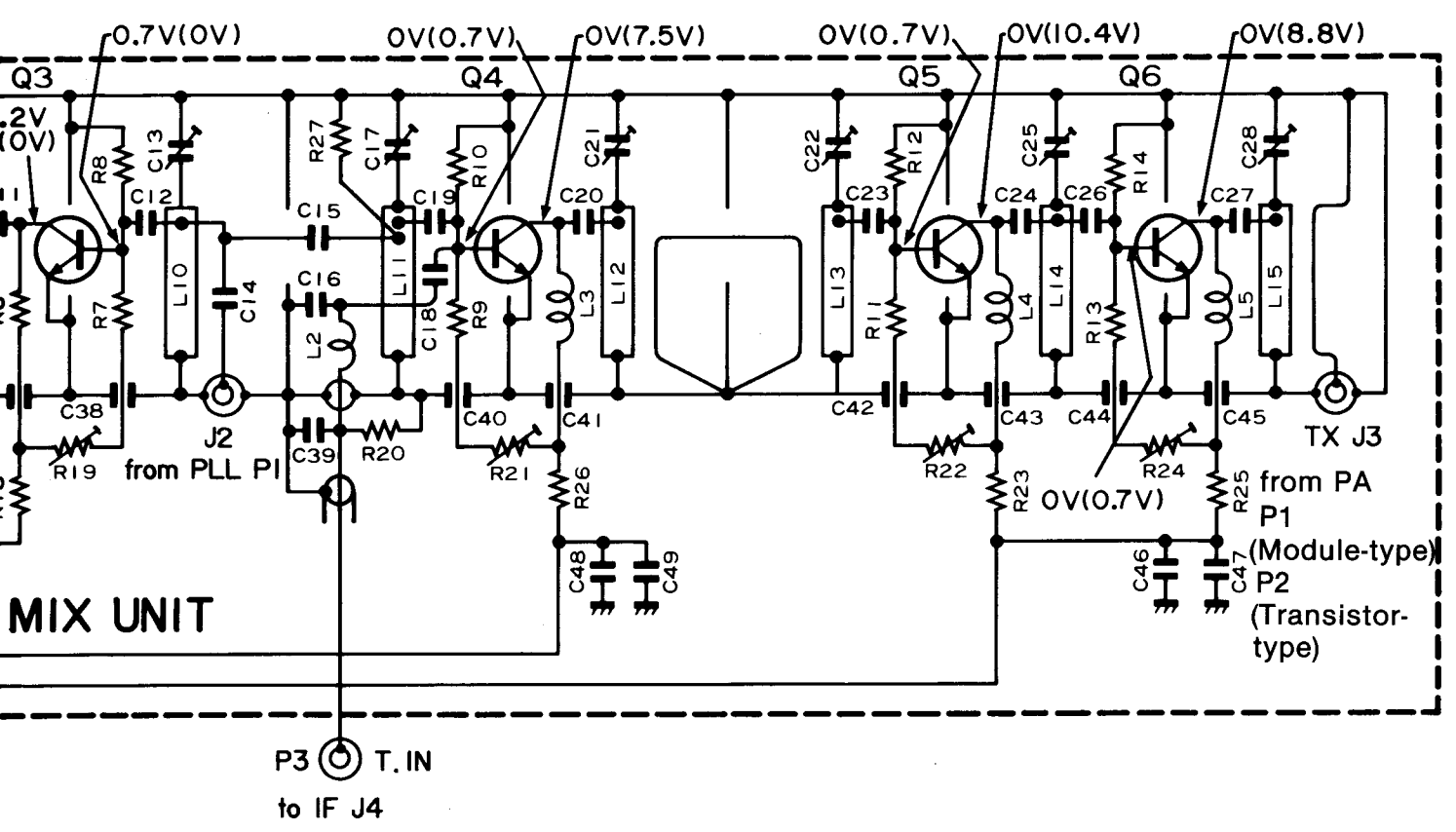
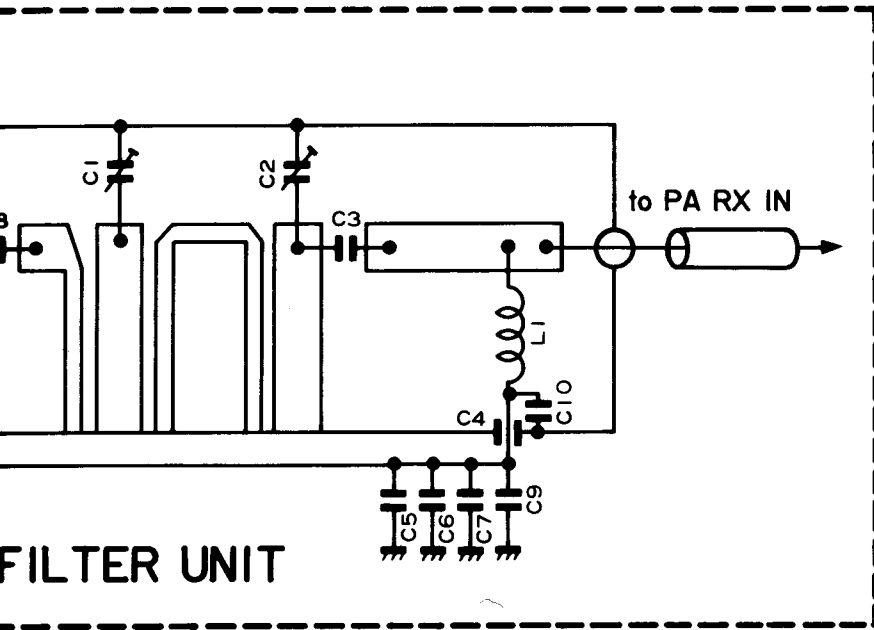

7-9 PA UNIT (MODULE-TYPE)

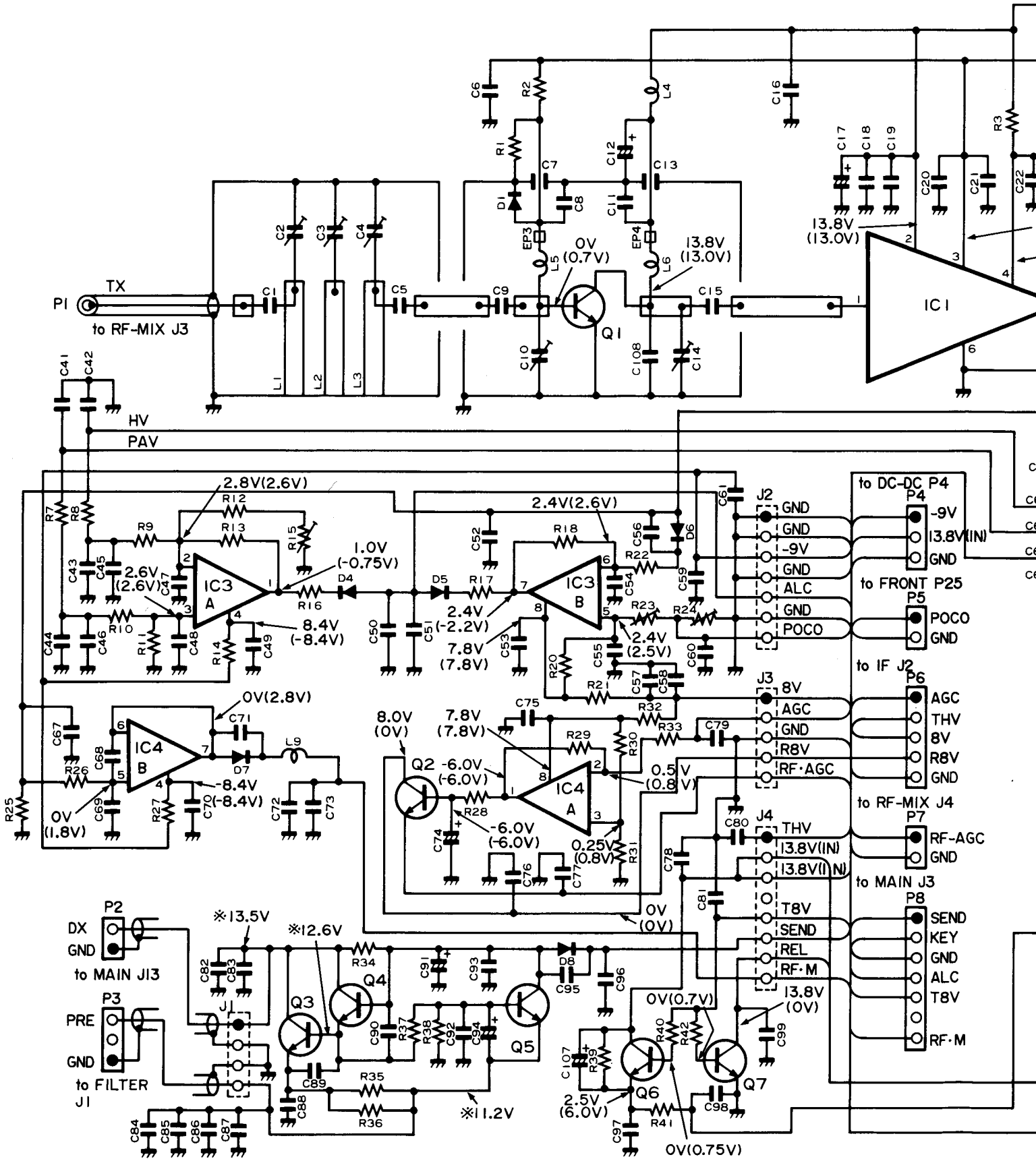

MEASUREMENT CONDITIONS

- VOLTMETER: 50k OHMS/V
- All voltage values shown in circuitry are DC voltage in Transmit and Receive mode
- ().....Voltage values at Transmit (FM high power 10w)
- * make figures PRE AMP ON

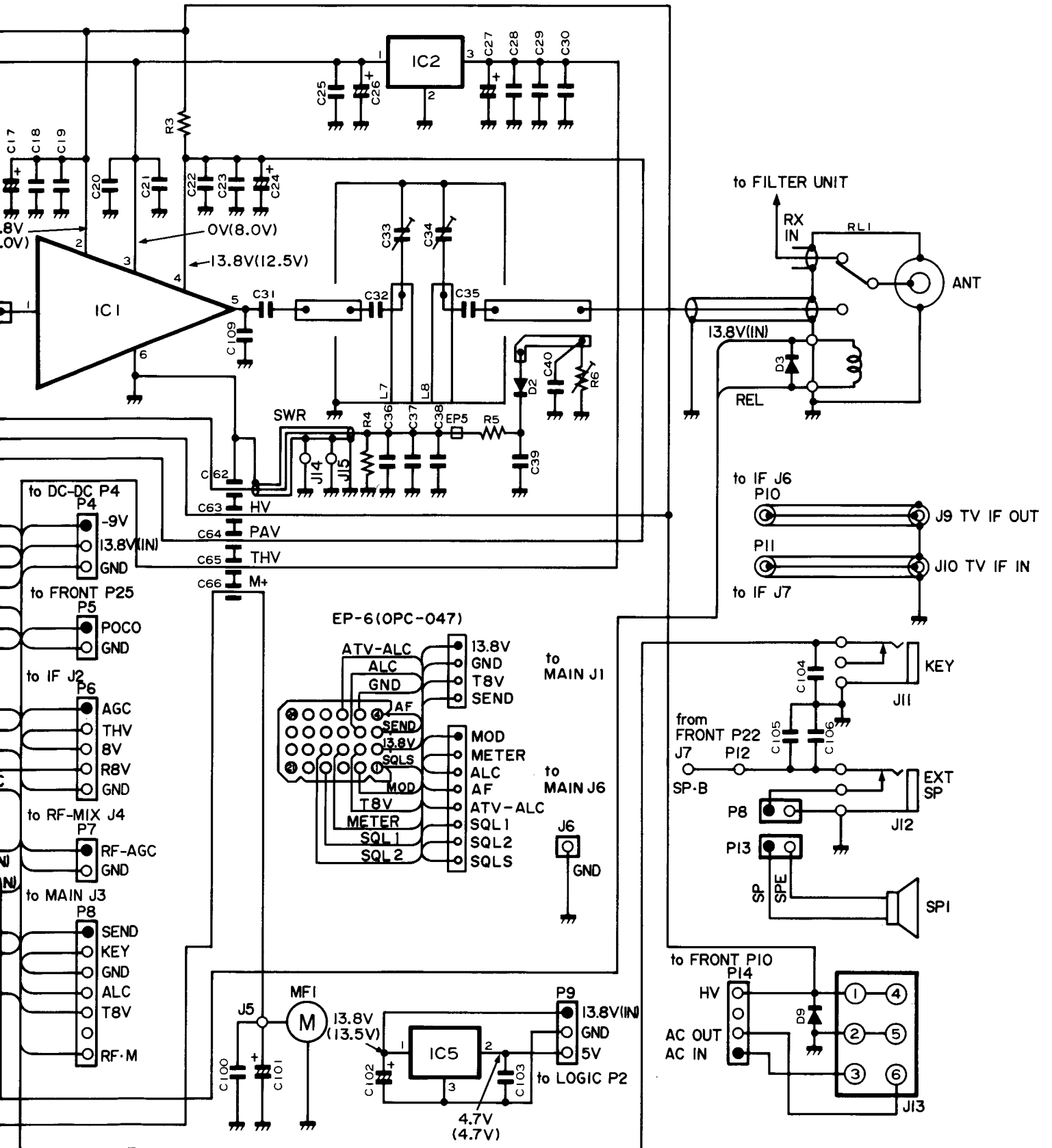

7-10 PA UNIT (TRANSISTOR-TYPE)

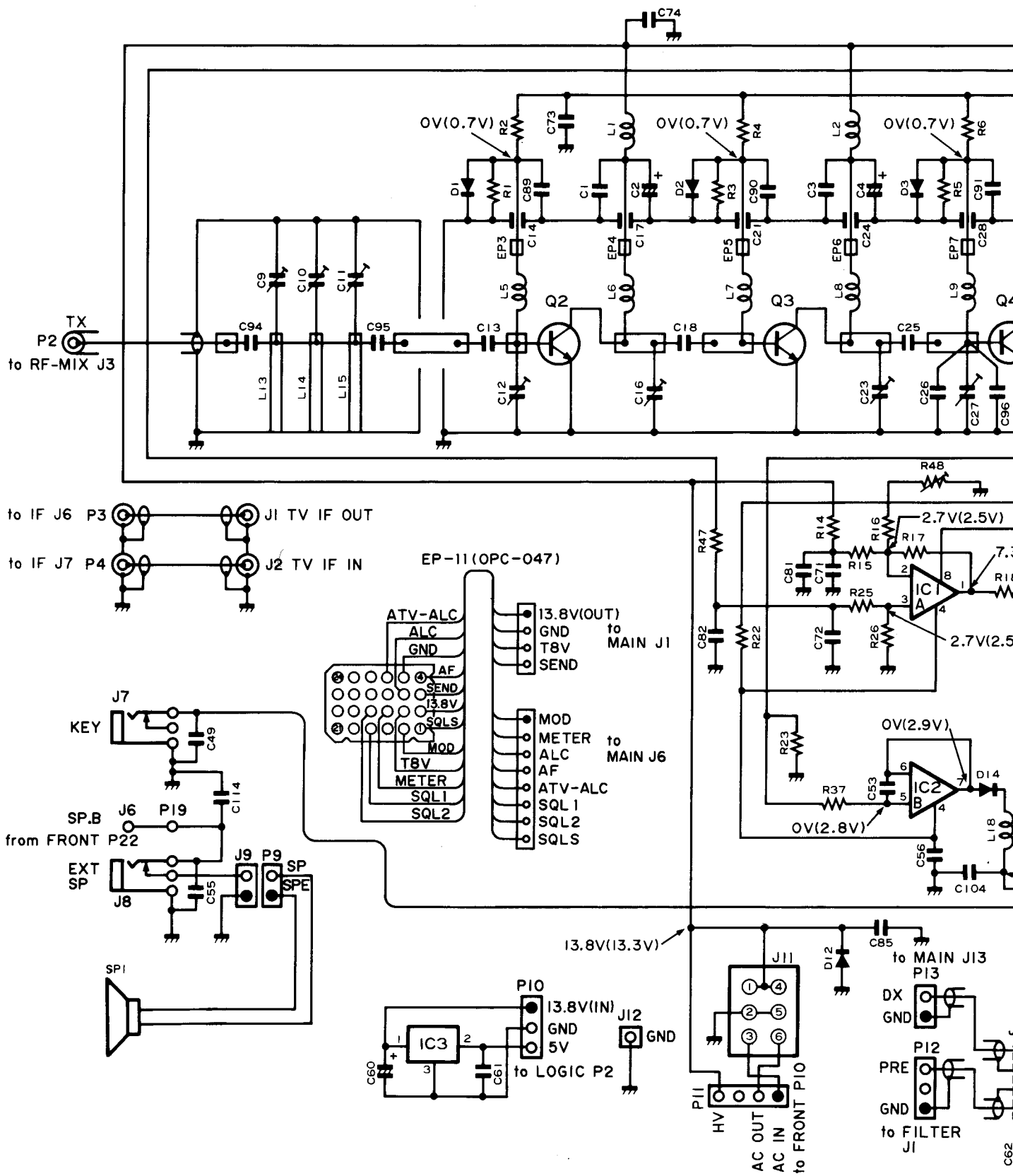

MEASUREMENT CONDITIONS

- VOLTMEETER: 50k OHMS/V
- All voltage values shown in circuitry are DC voltage in Transmit and Receive mode
- () Voltage values at Transmit (FM high power 10w)

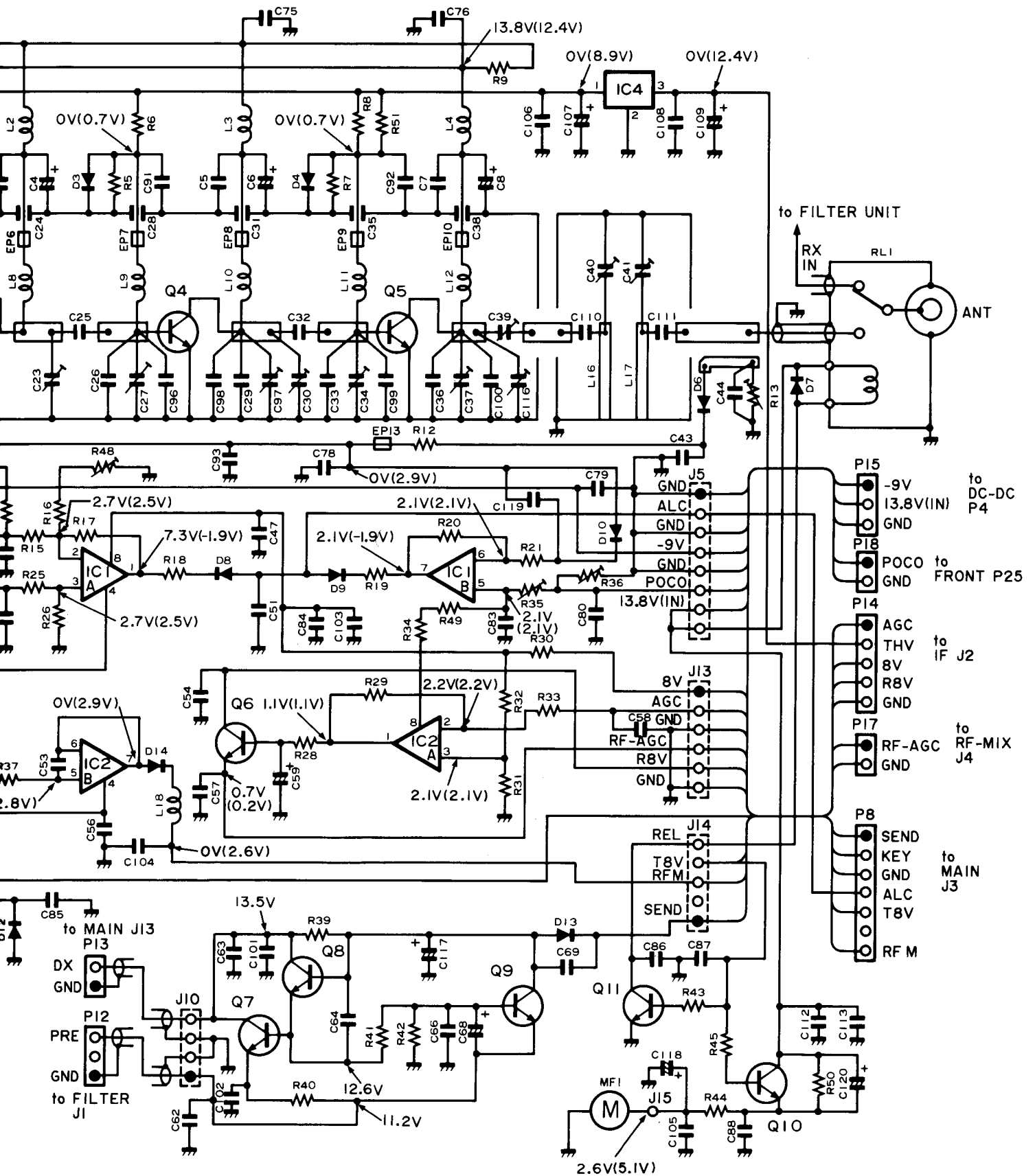

SECTION 8 BOARD LAYOUTS

8-1 FRONT UNIT (VR UNIT, MIC UNIT, DISPLAY UNIT)

VR UNIT

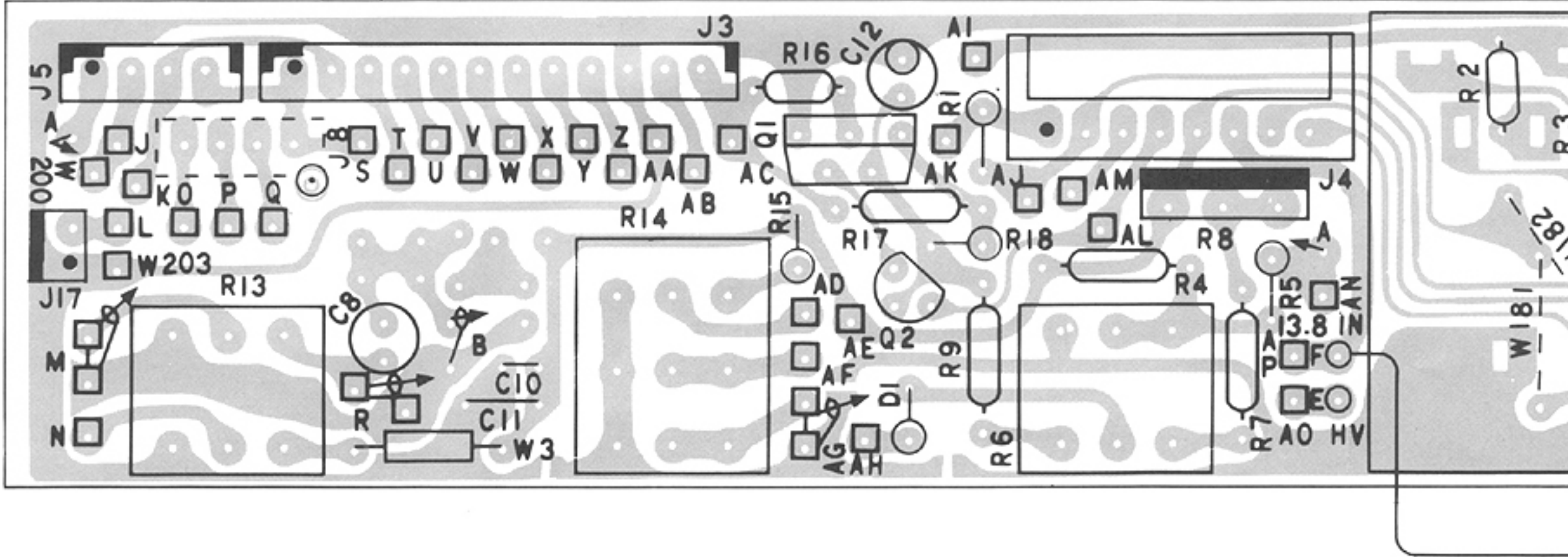
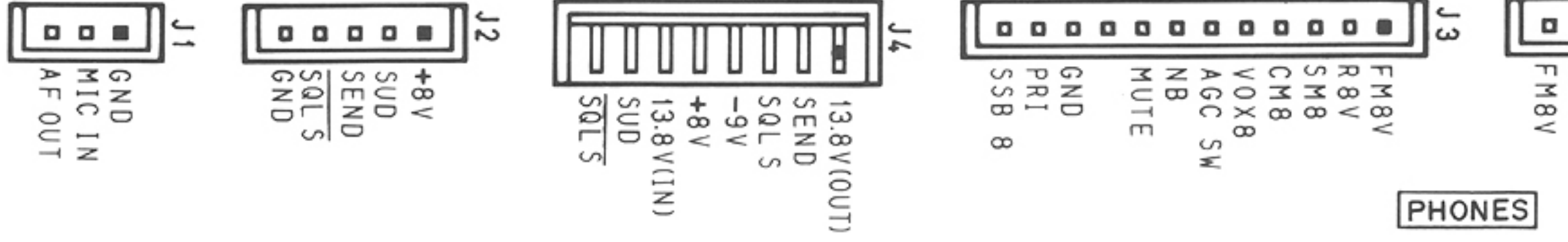

DISPLAY UNIT

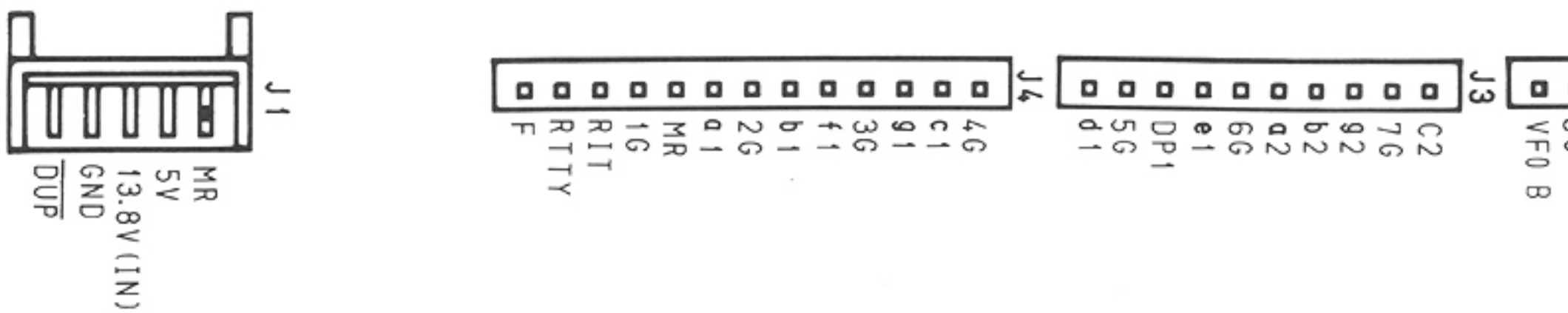
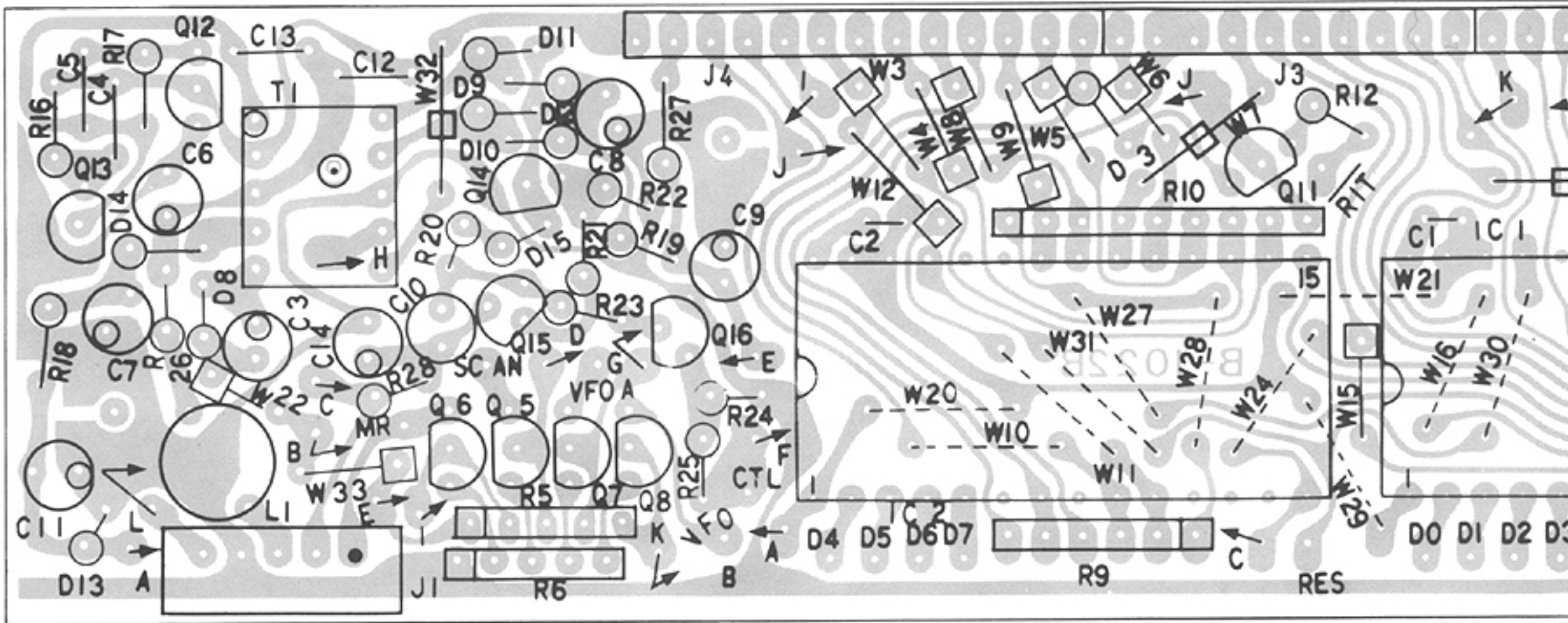

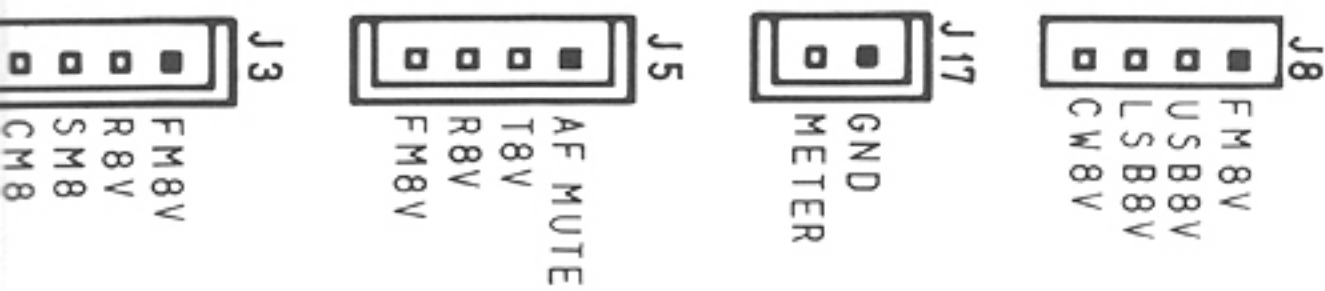

PHONES

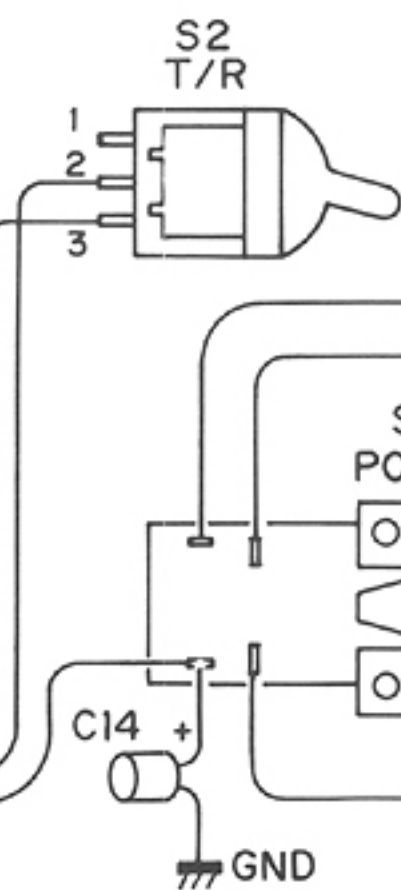
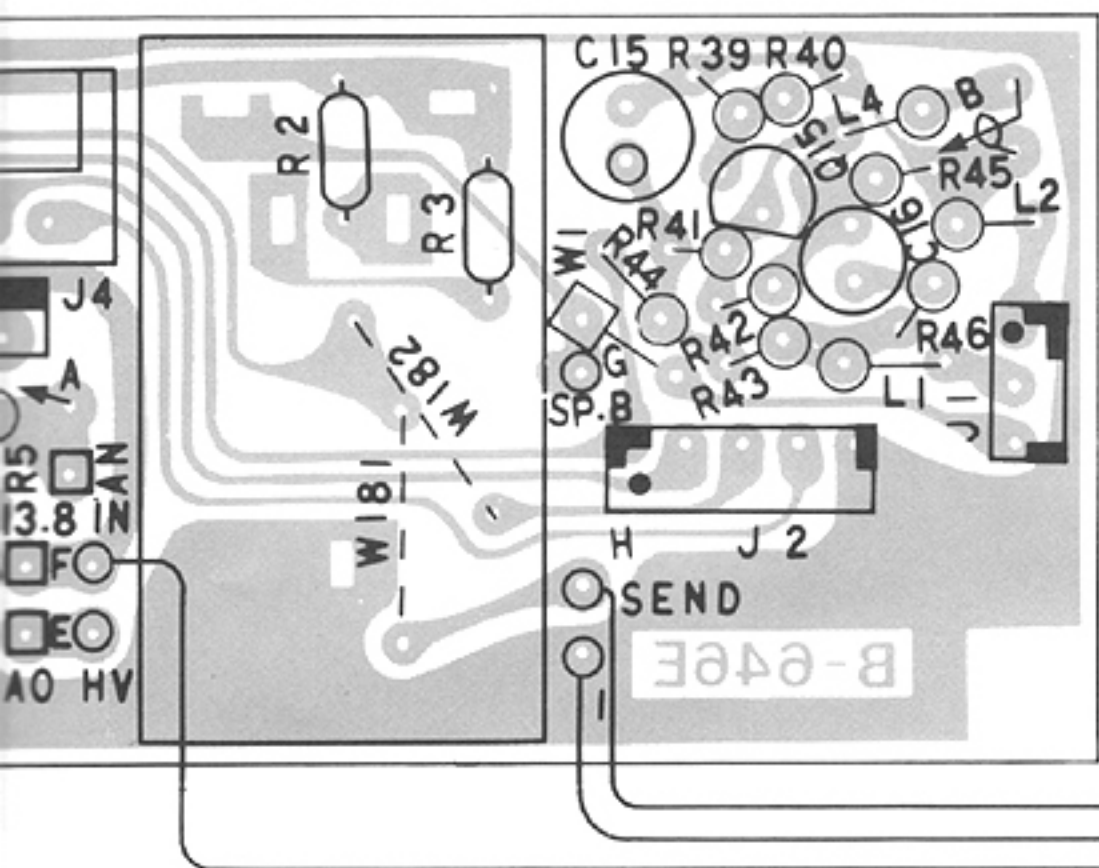

to PA P14 (Module-type)
P11 (Transistor-type)

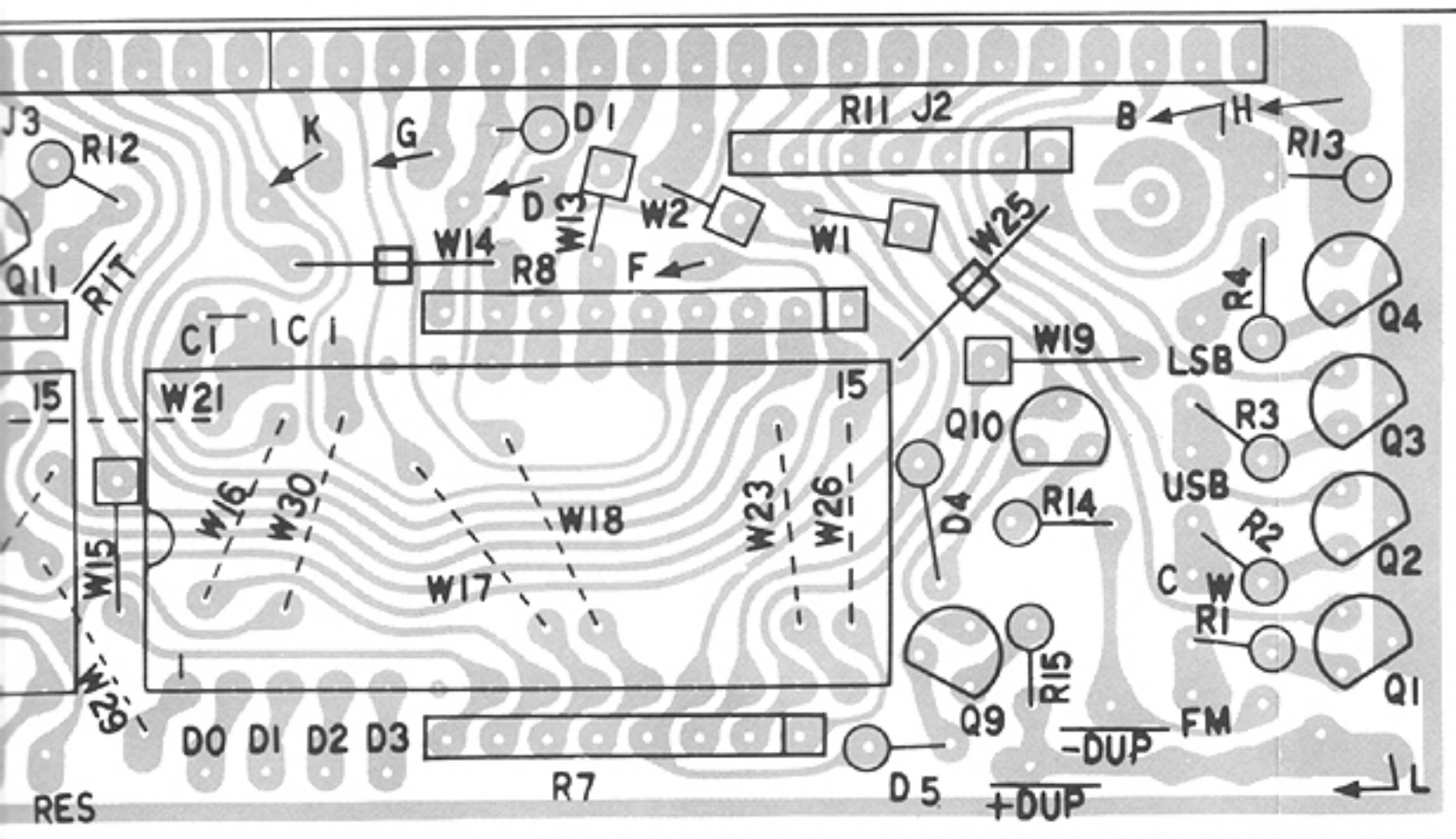
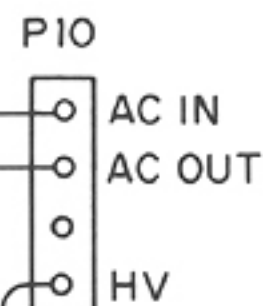

MIC UNIT

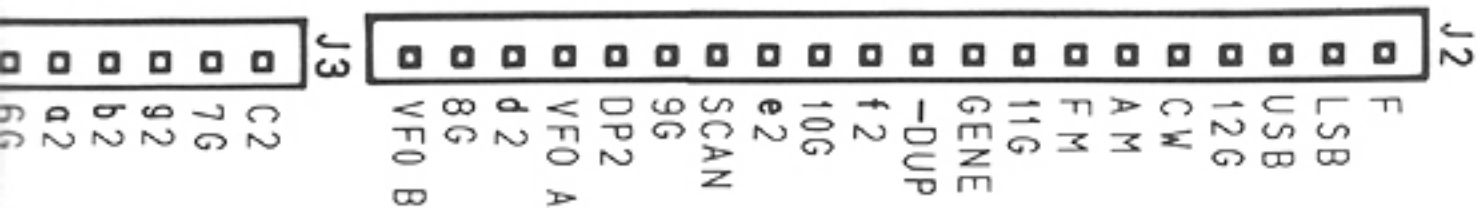
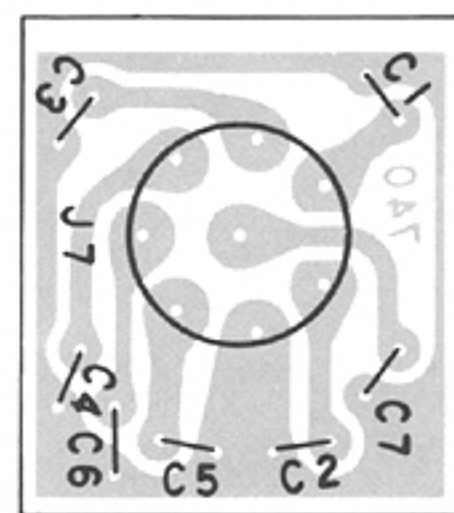

8-2 FRONT UNIT

S 6	S 4	S 8
OW	CHECK	+DUPLEX
S 5	S 26	S 7
SEL (#03 only)	TONE	-DUPLEX

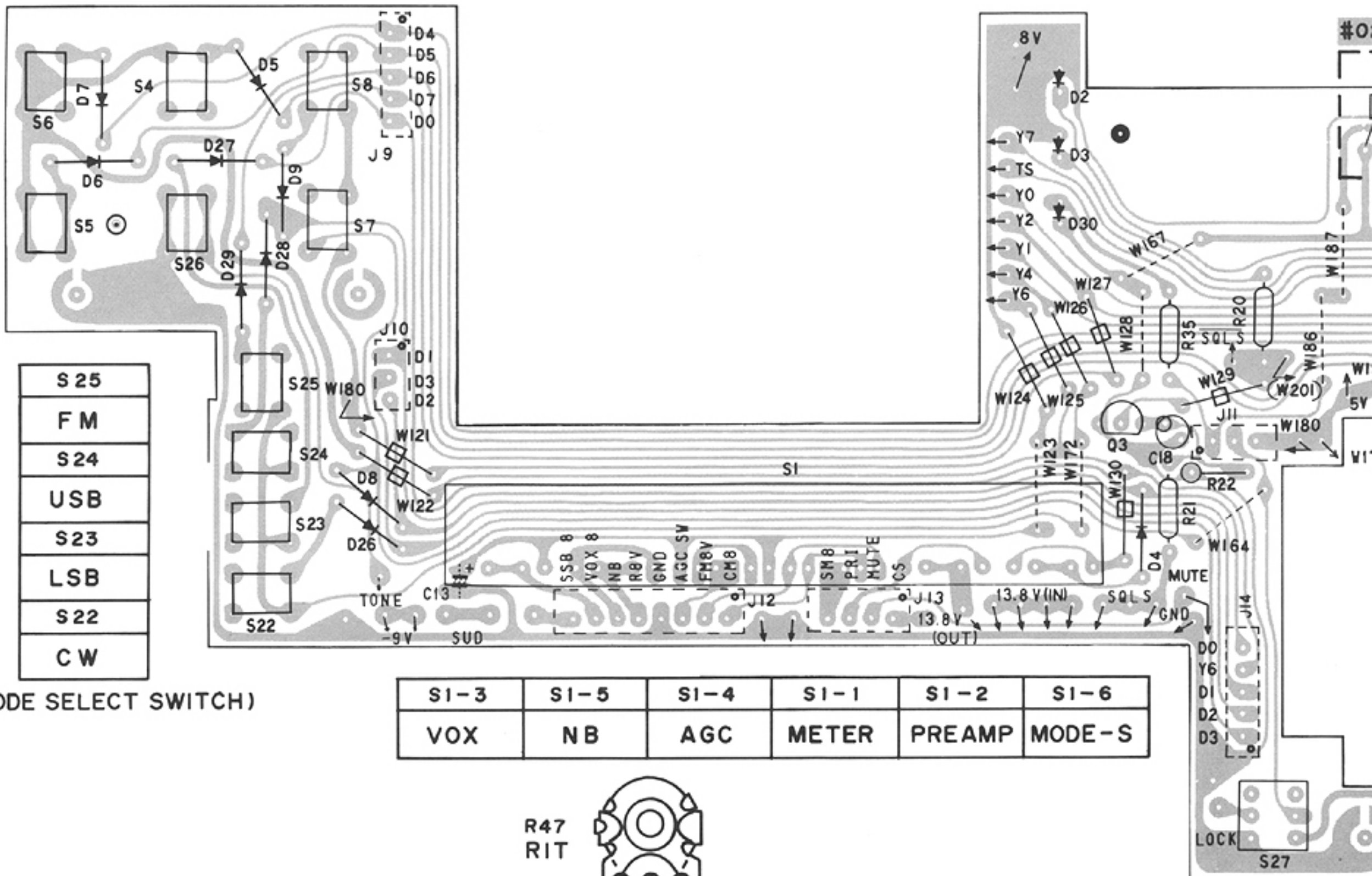

S 25
FM
S 24
USB
S 23
LSB
S 22
CW

(MODE SELECT SWITCH)

S1-3	S1-5	S1-4	S1-1	S1-2	S1-6
VOX	NB	AGC	METER	PREAMP	MODE-S

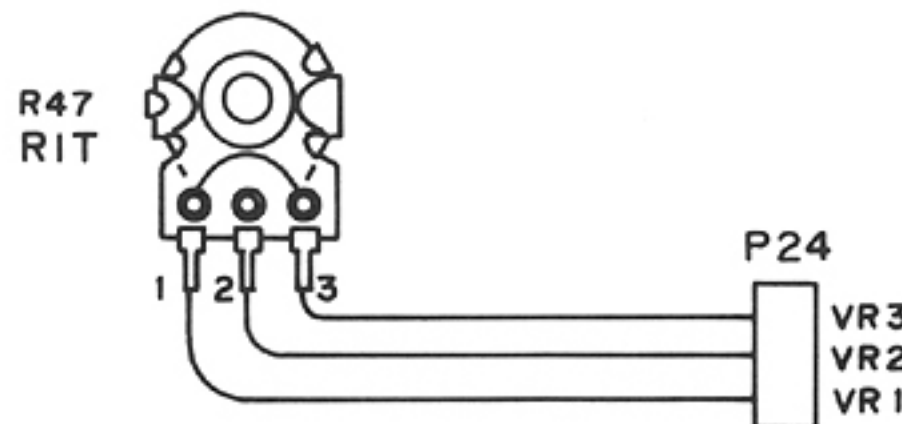

S 27
DIAL LOCK AND SPEECH

S16	S15	S14
A/B	A=B	SCAN
S13	S12	S11
VFO/M	WRITE	M ▶ VFO

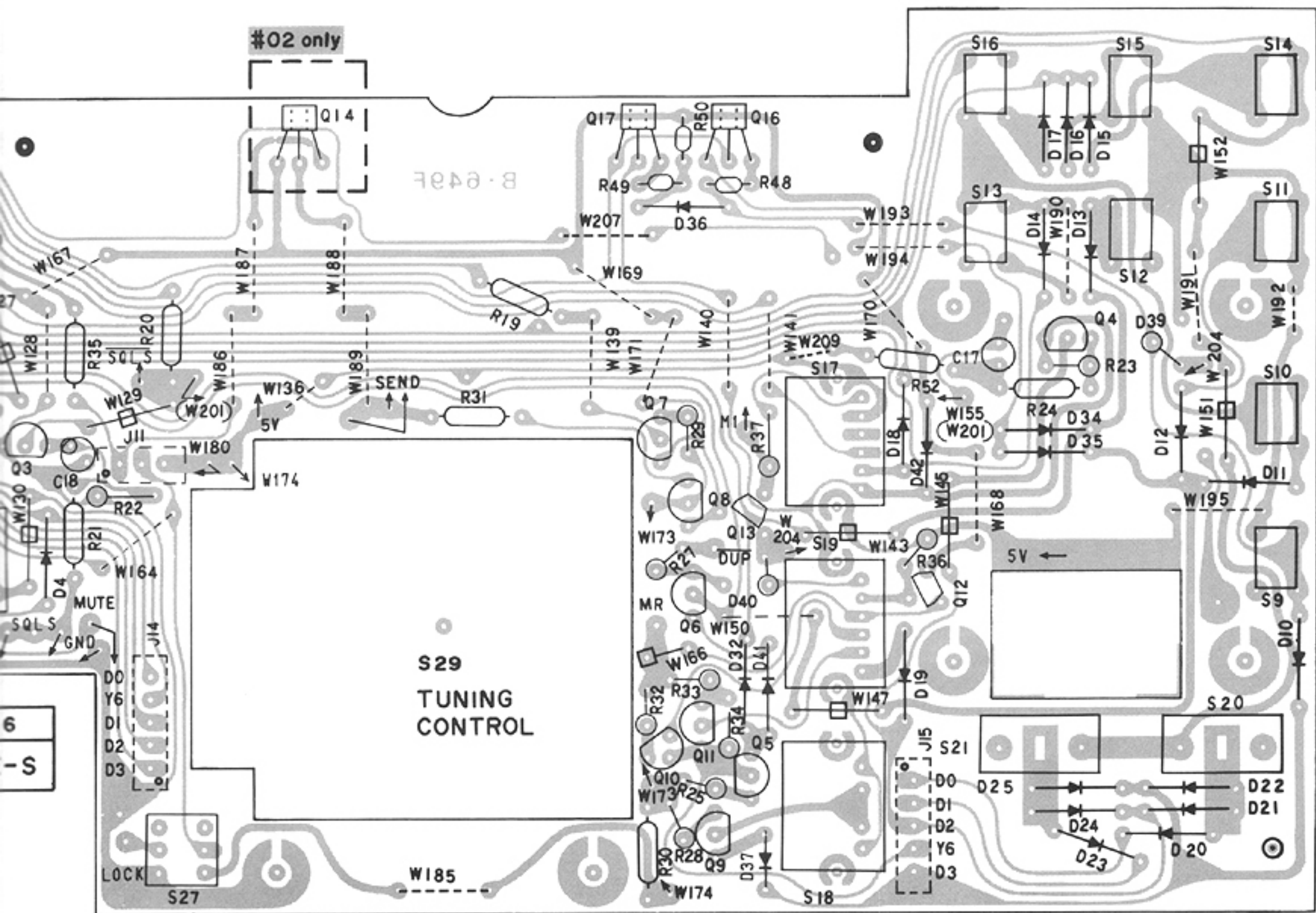

S10
RIT
S9
MHz

S27
DIAL LOCK AND SPEECH

S17
TS
S19
DFS
S18
SPLIT

S21	S20
MHz DOWN	MHz UP

8-3 MAIN UNIT

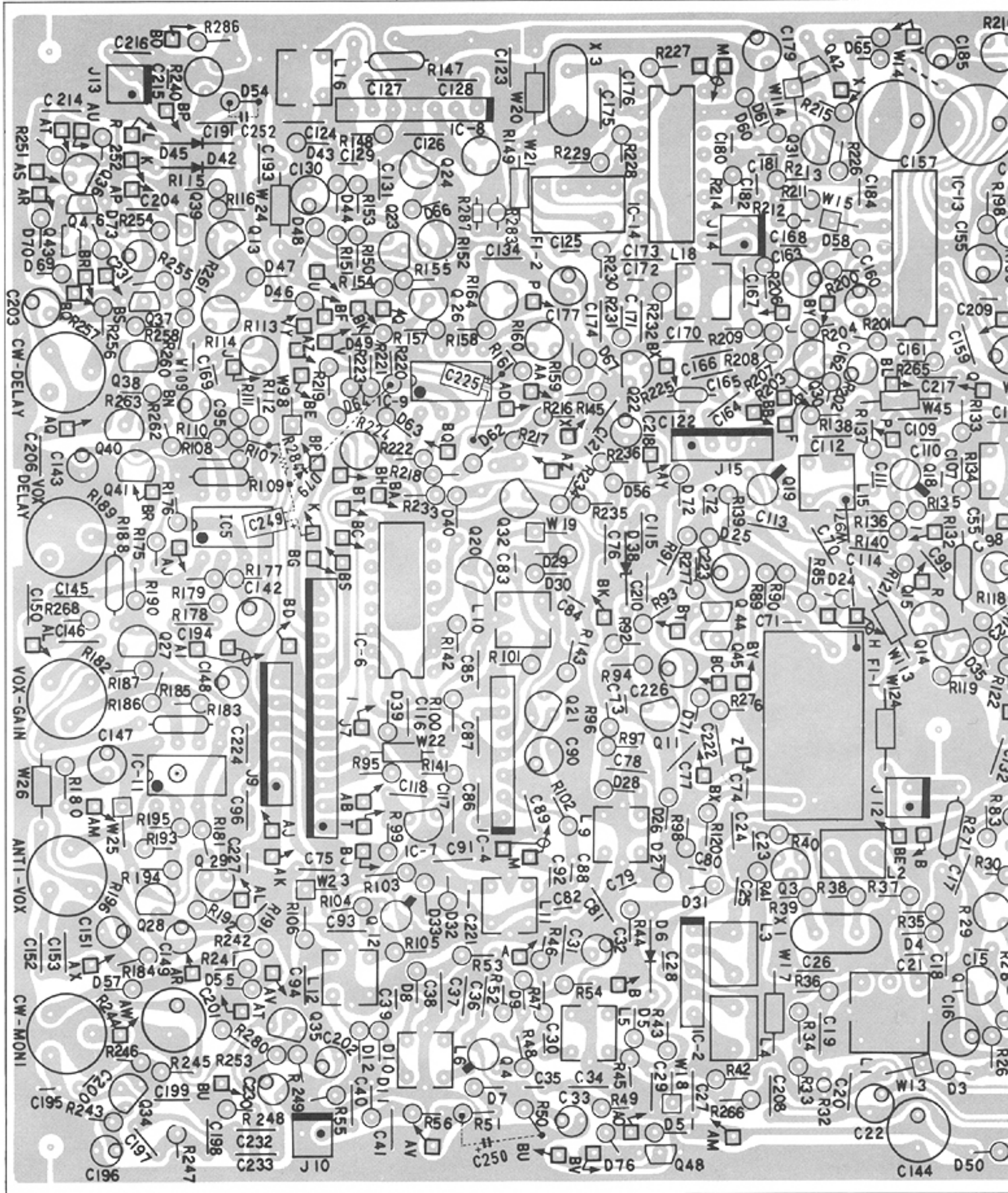
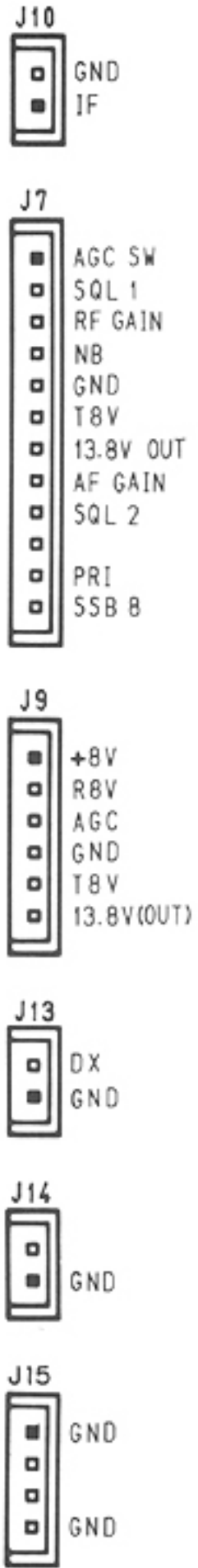

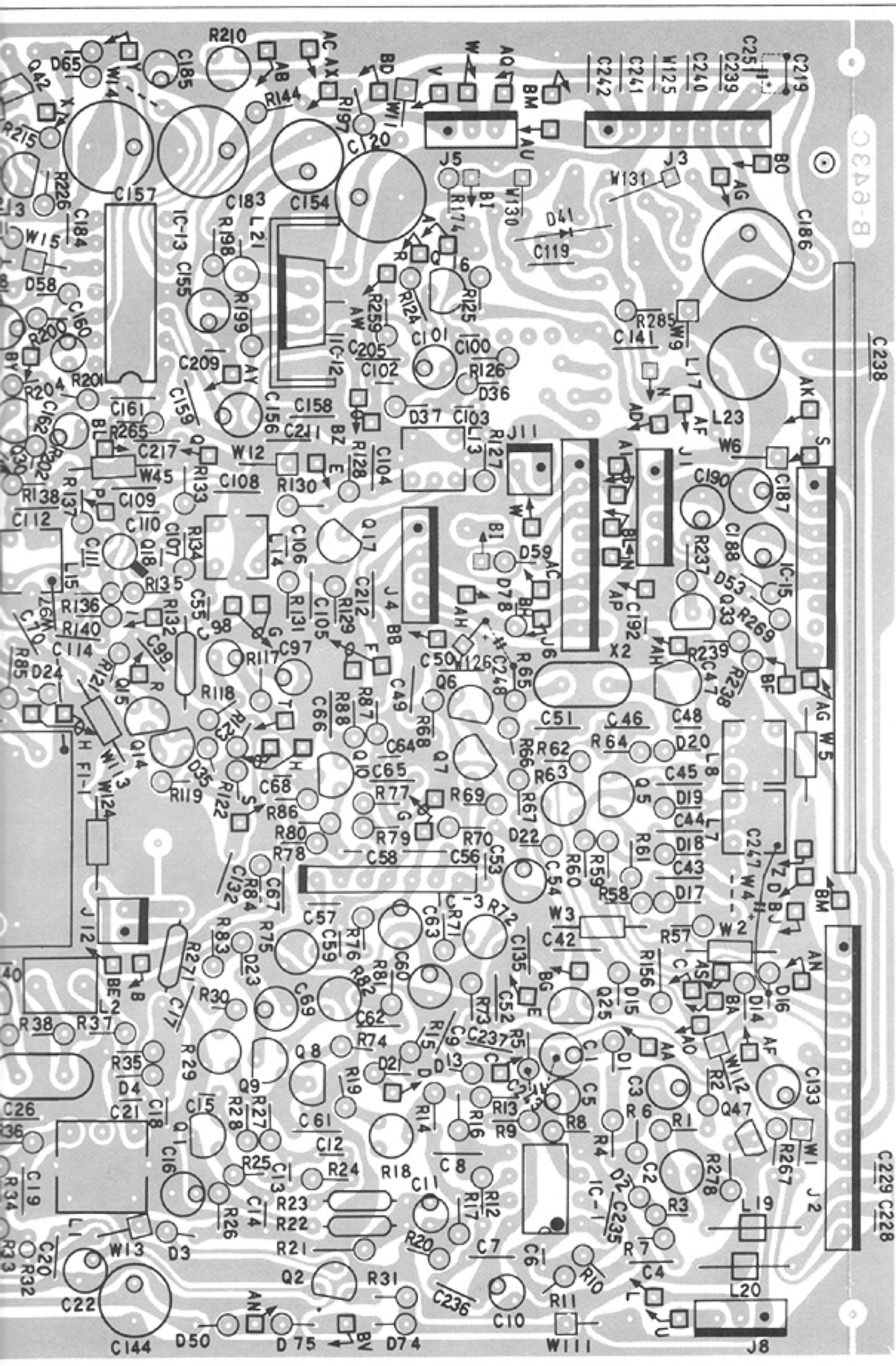

- J2**
 - SEND
 - R8V
 - USB 8V
 - CW 8V
 - LSB 8V
 - +8V
 - 13.8V(IN)
 - GND
 - MIC
 - GND
 - 9V
- J3**
 - SEND
 - KEY
 - GND
 - ALC
 - T8V
 - RF M
- J4**
 - TONE
 - GND
 - MUTE
 - SQL S
- J5**
 - SPA
 - METER
 - VOX 8
- J6**
 - OD
 - METER
 - ALC
 - AF
 - ATV-ALC
 - SQL 1
 - SQL 2
 - SQL S
- J7**
 - 13.8V OUT
 - GND
 - T8V
 - SEND
- J8**
 - FM8V
 - SM8
 - CM8
- J9**
 - VOX
 - GND
- J10**
 - ST
 - GND
- J11**
 - VOX
 - GND
- J12**
 - ST
 - GND

8-4 PLL UNIT

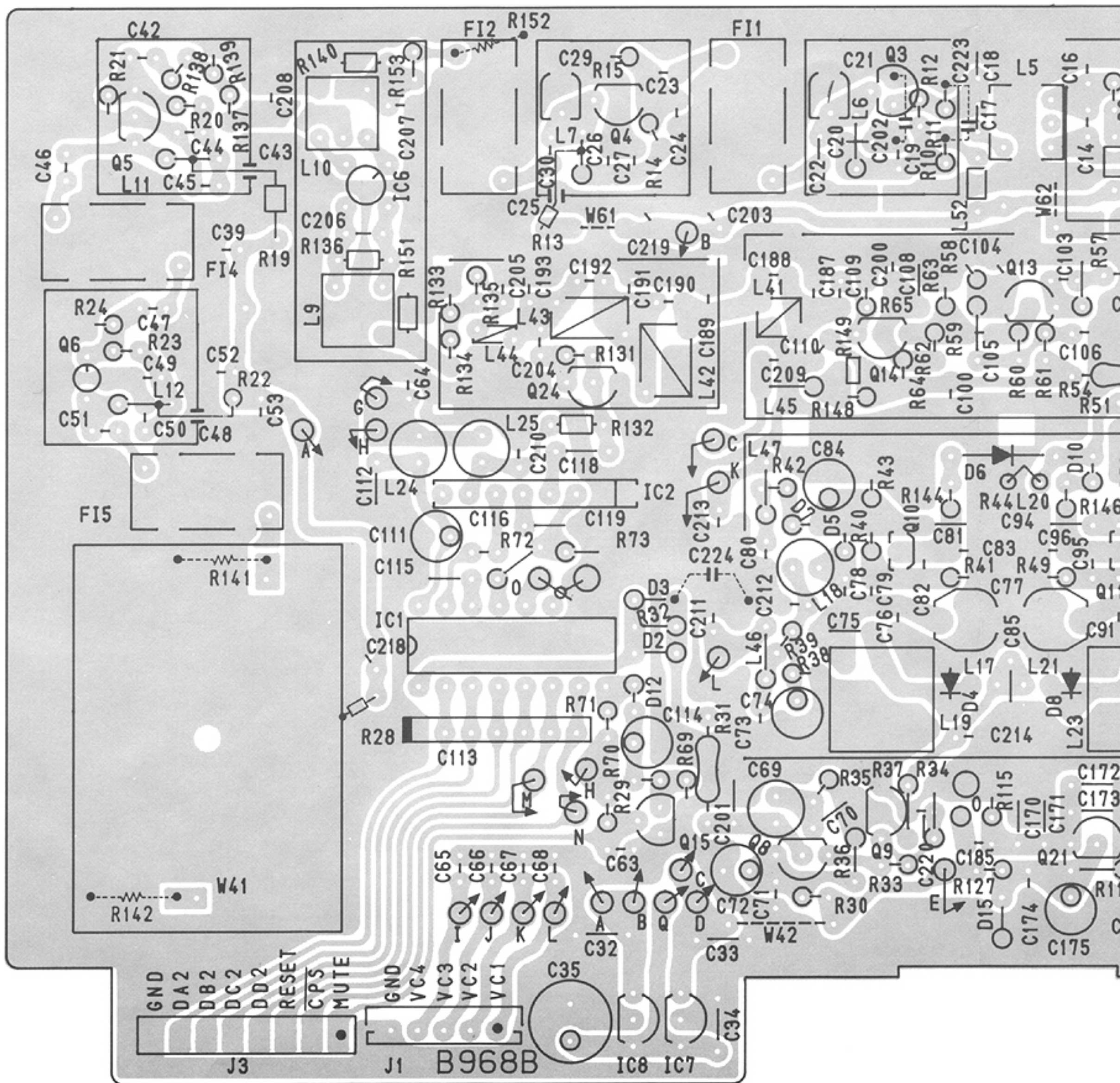

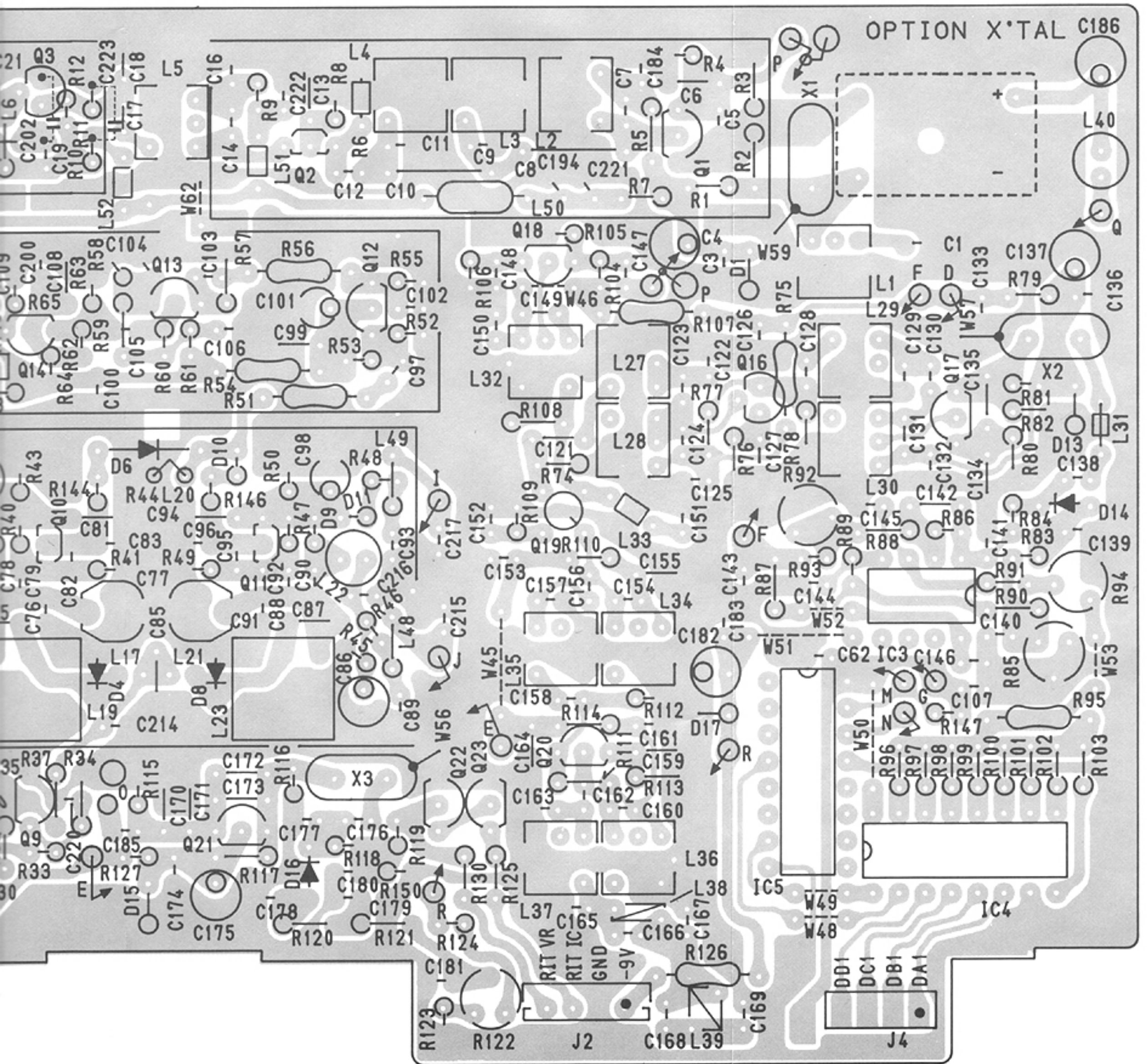

8-5 LOGIC UNIT (#02)

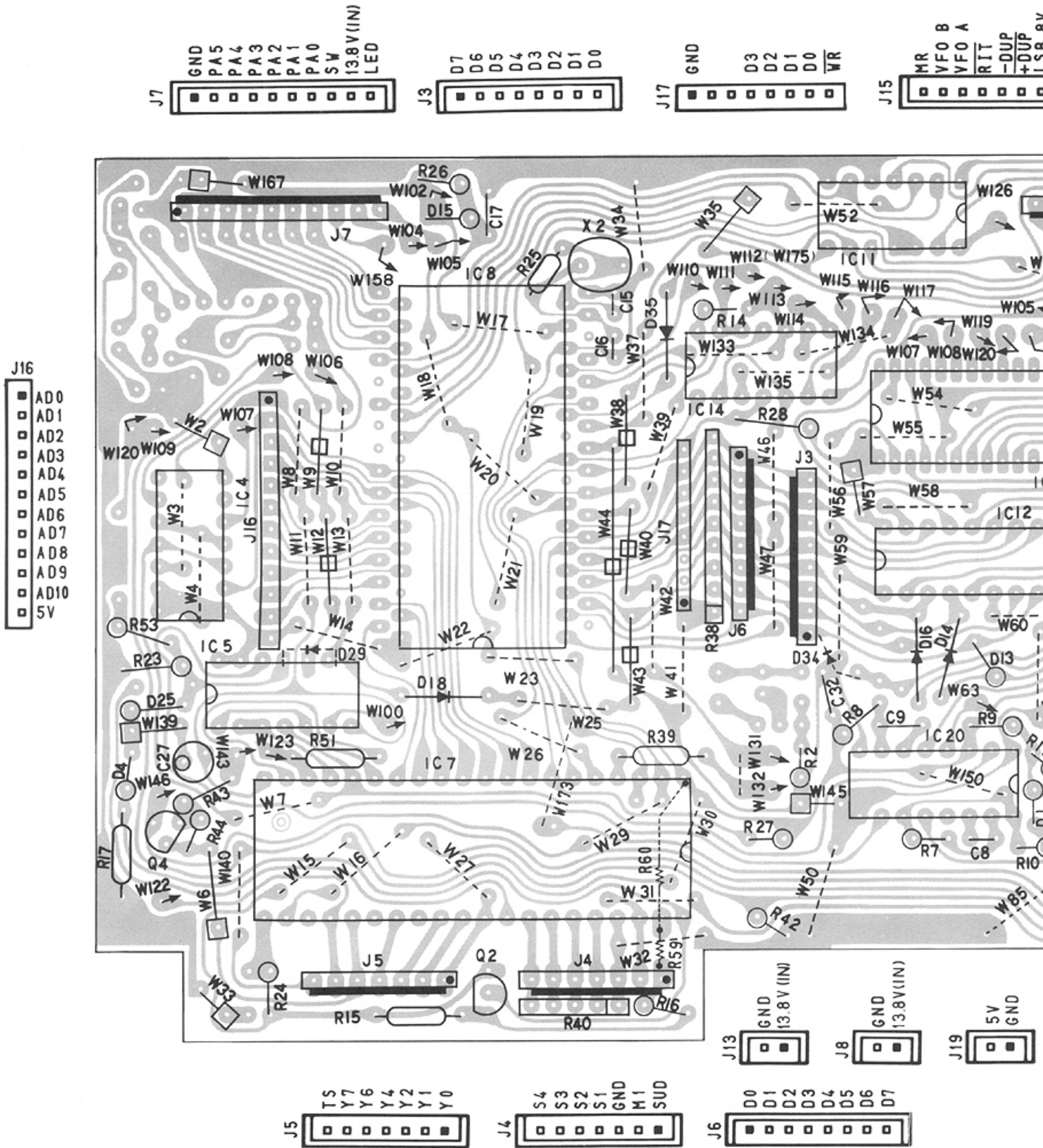

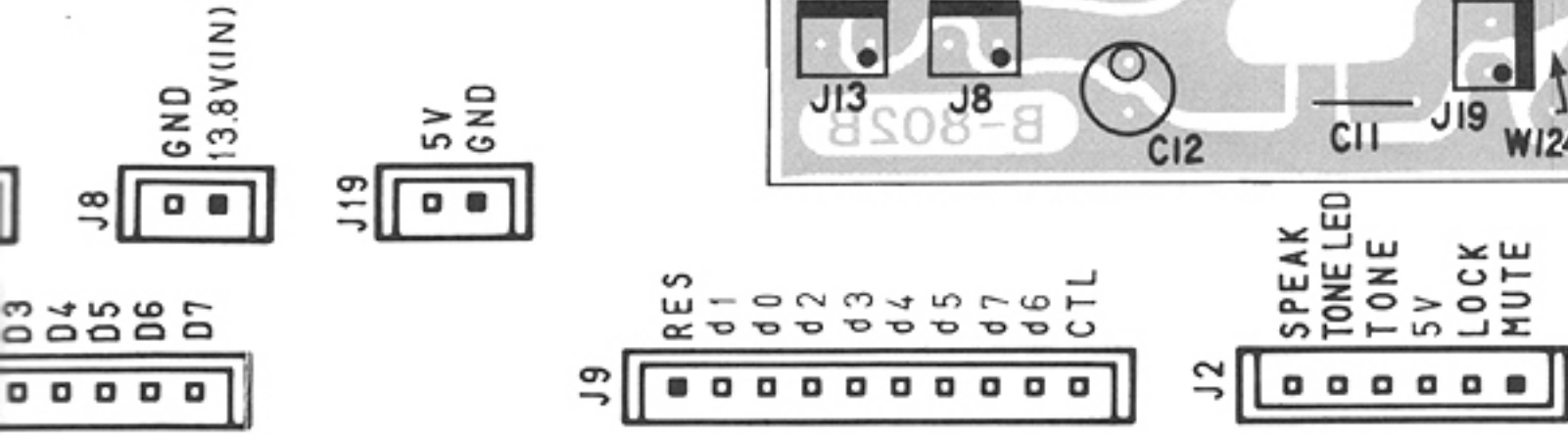
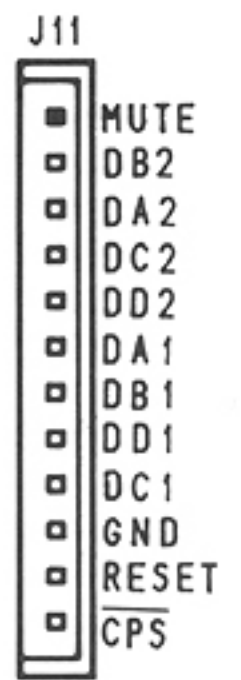
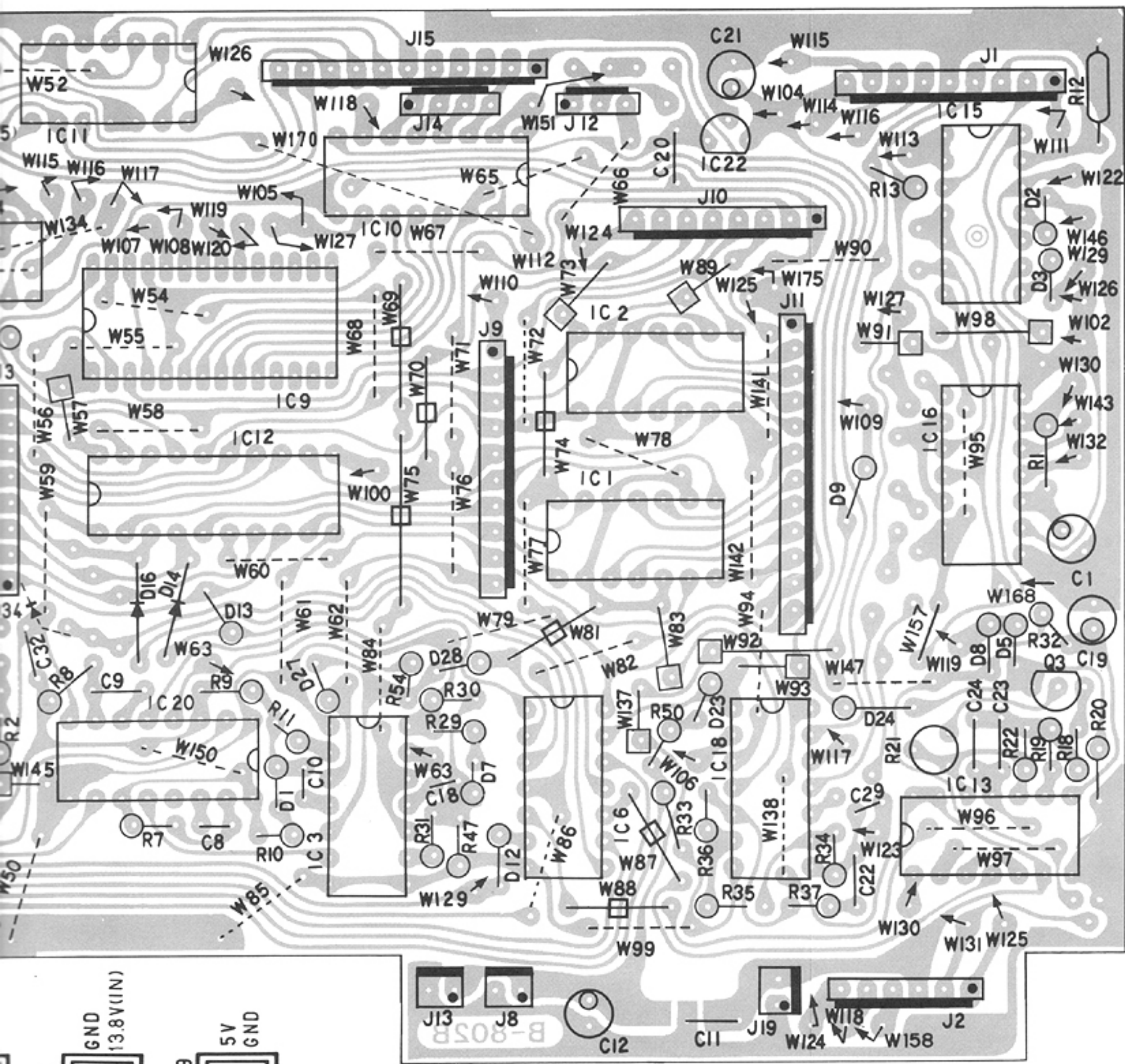
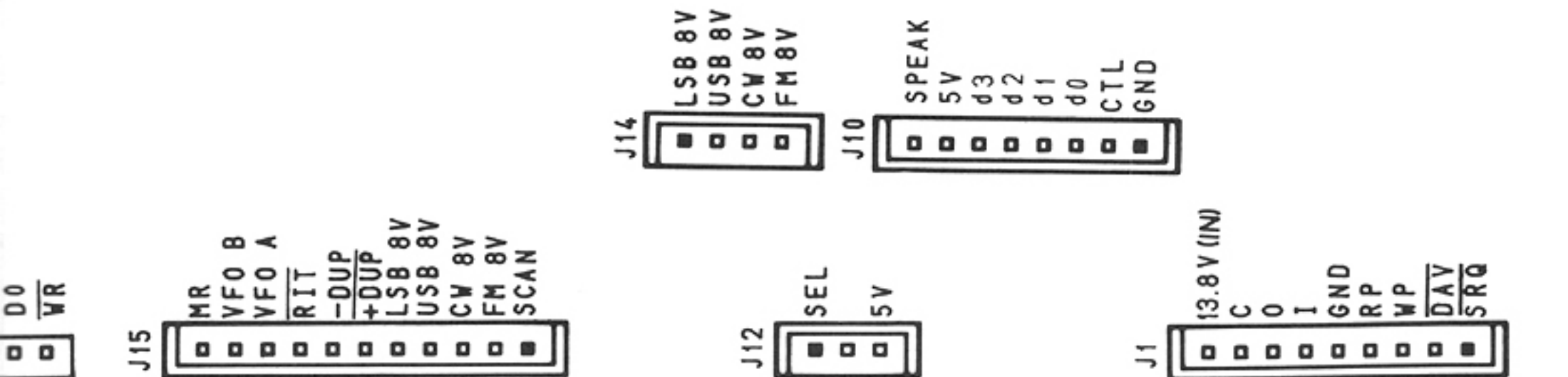

8-5 LOGIC UNIT (#03, #04)

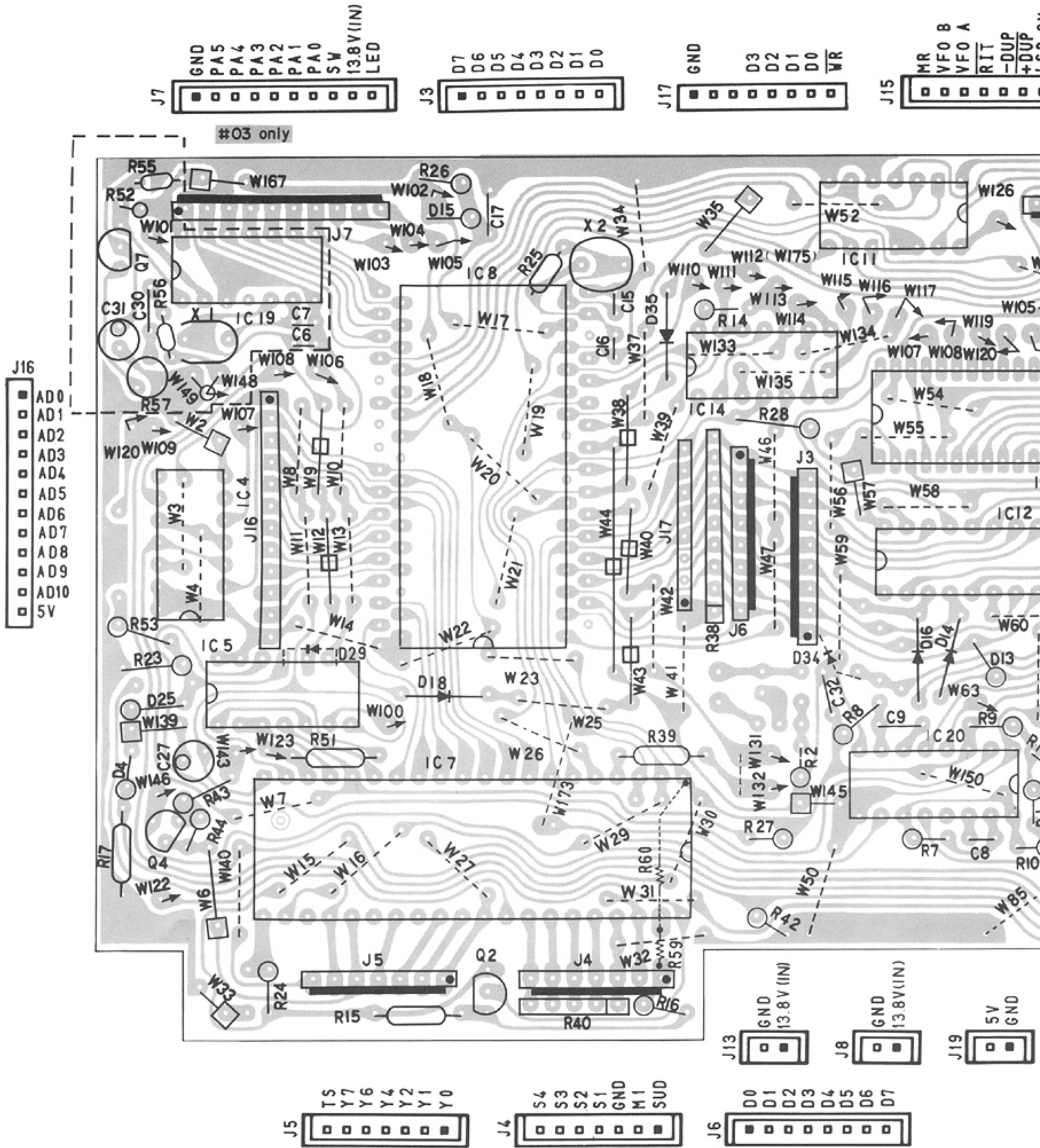

8-6 VCC UNIT, DC-DC UNIT (#02), DC-DC UNIT (#03, 04), JACK UNIT, DOUBLER UNIT, RAM UNIT (on the

VCC UNIT

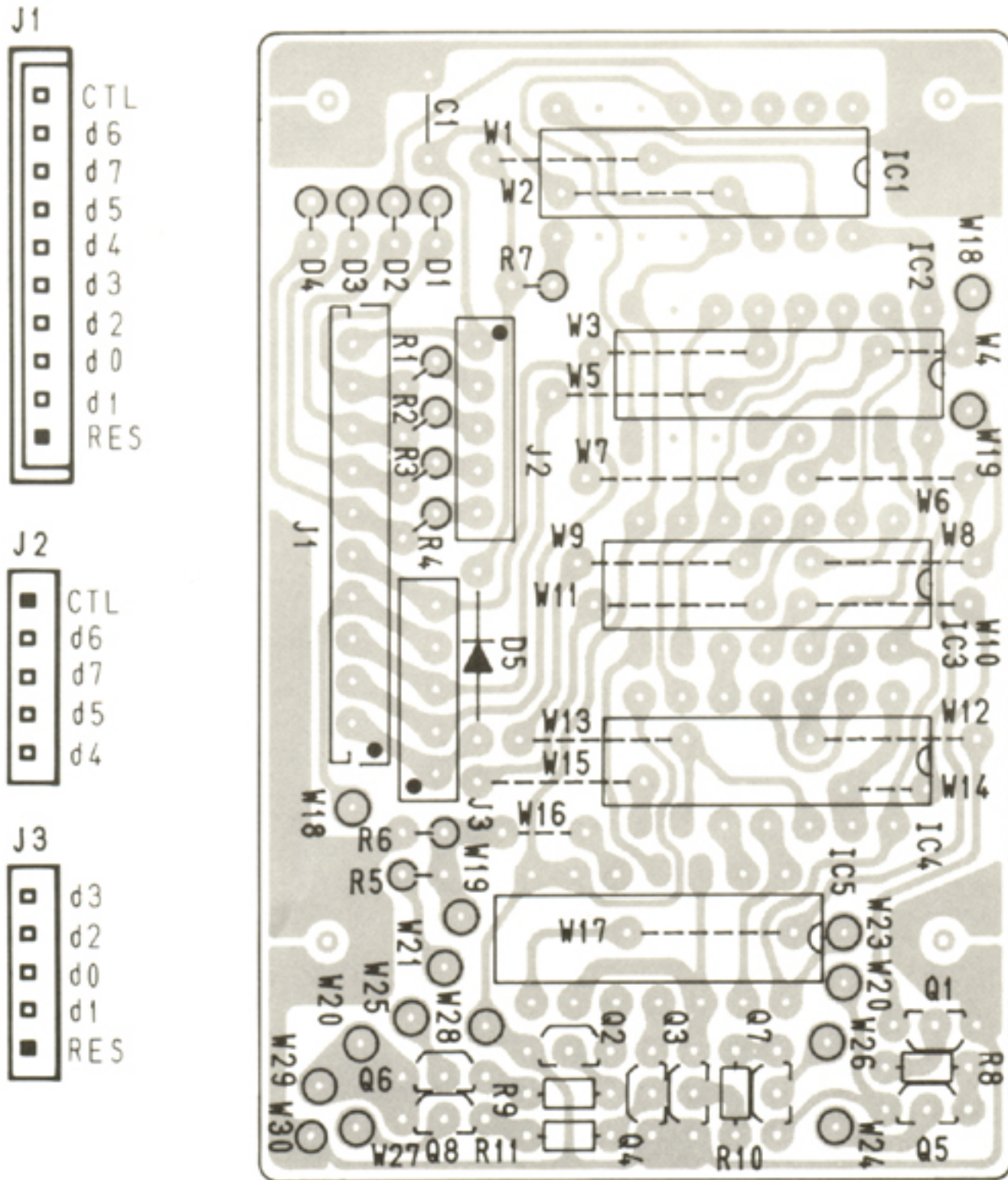

DC-DC UNIT (#02)

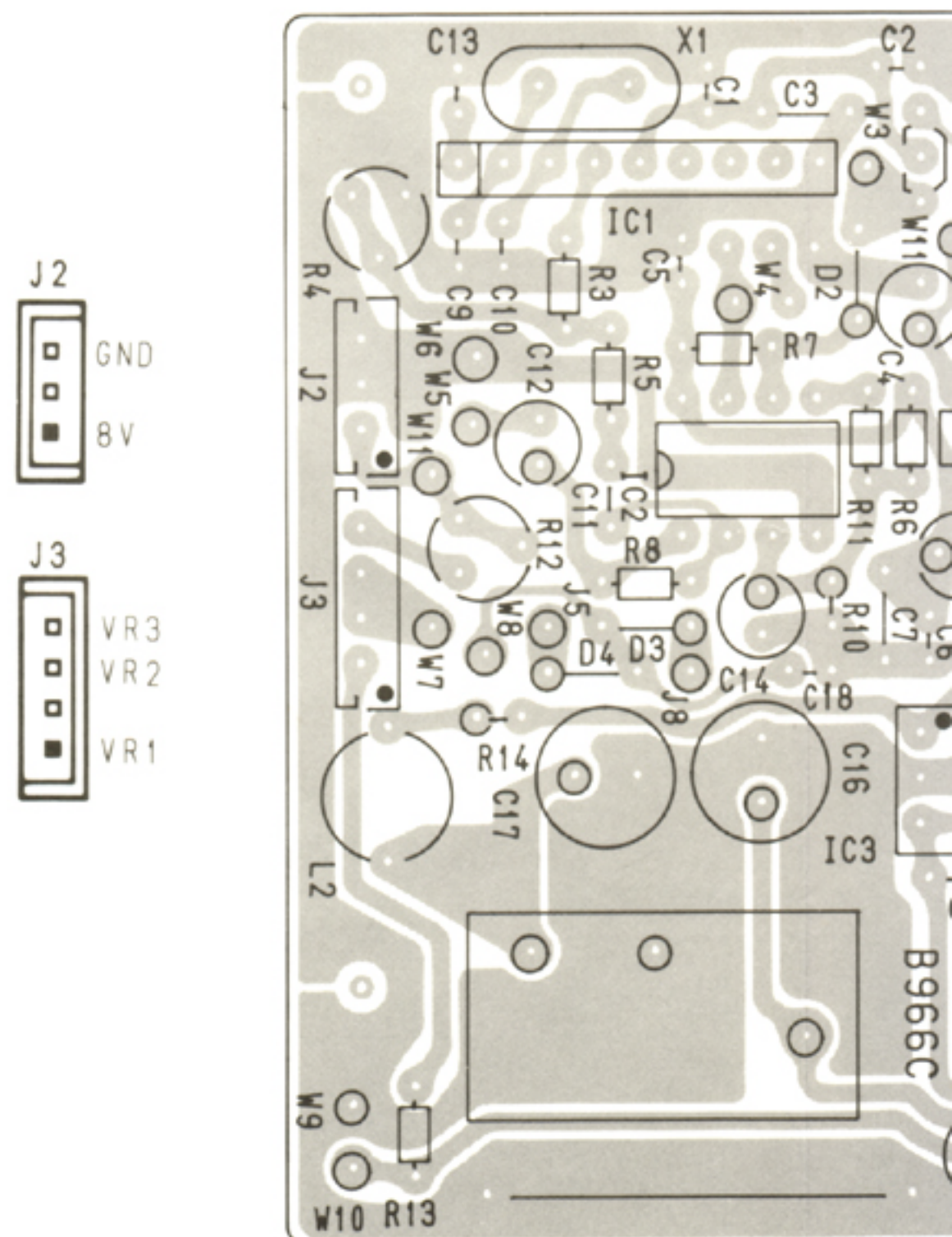

JACK UNIT

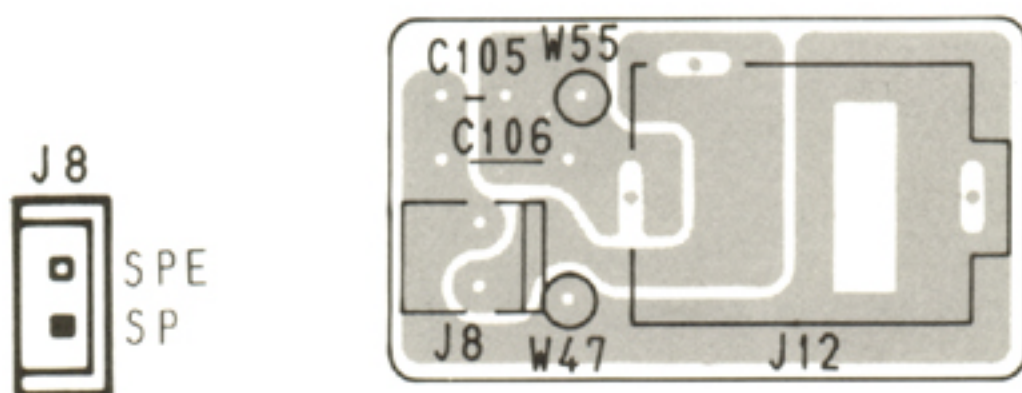

DOUBLER UNIT

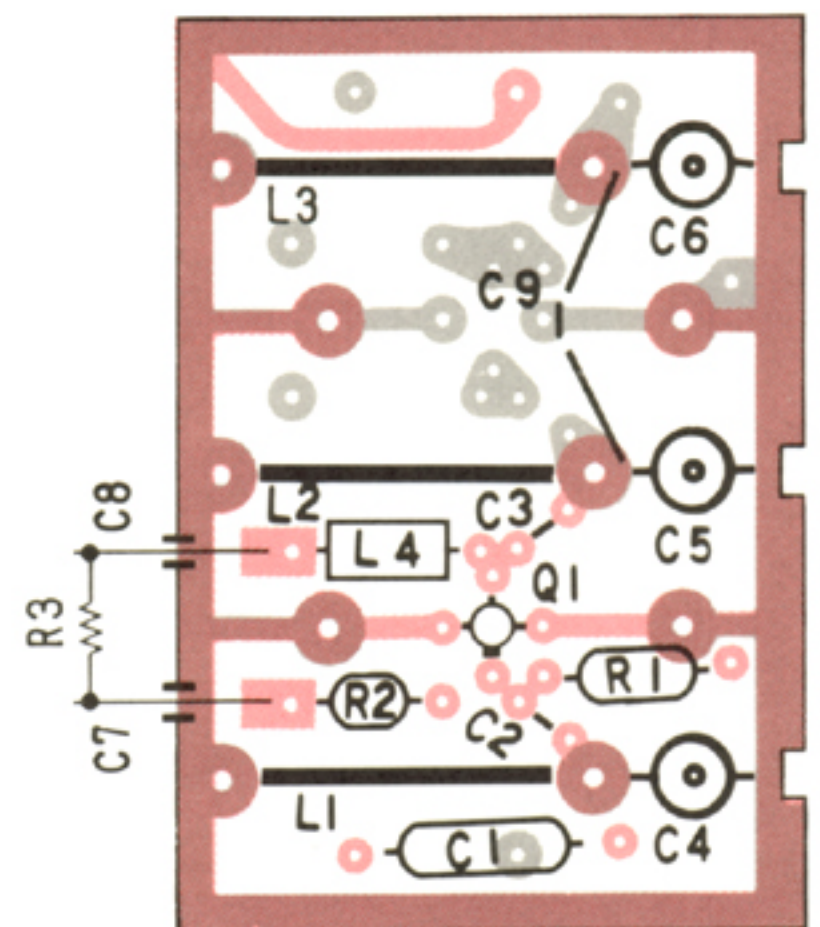

UNIT (on the LOGIC UNIT)

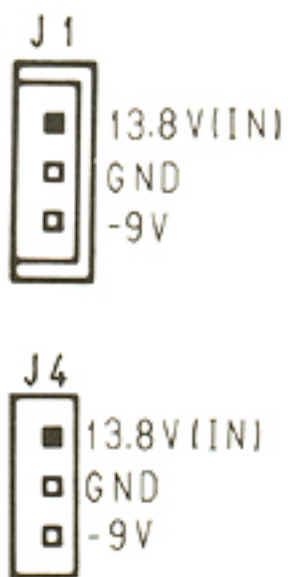
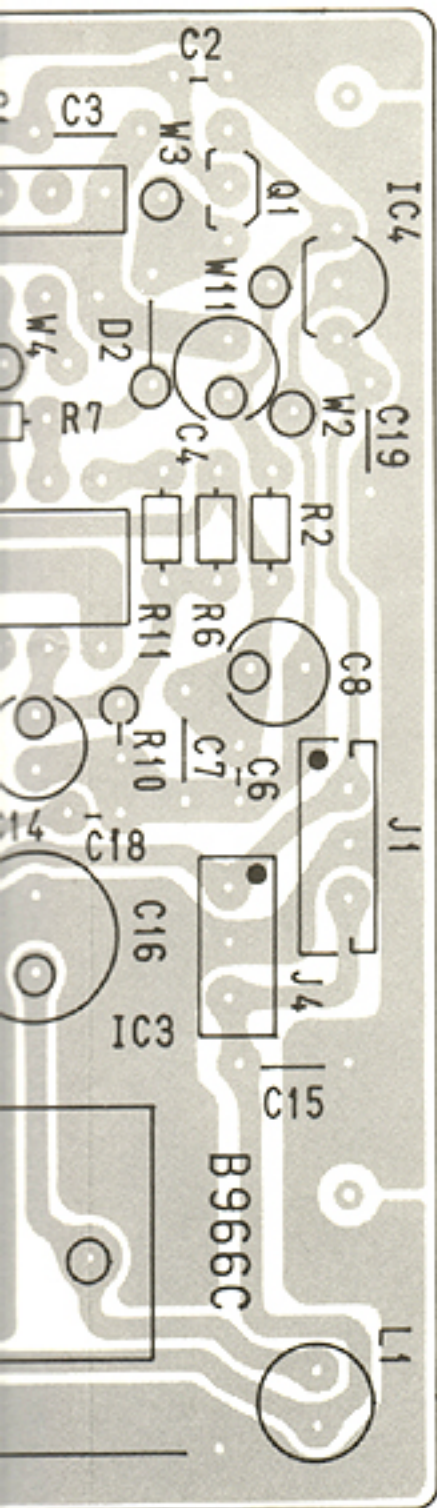

DC-DC UNIT (#03, #04)

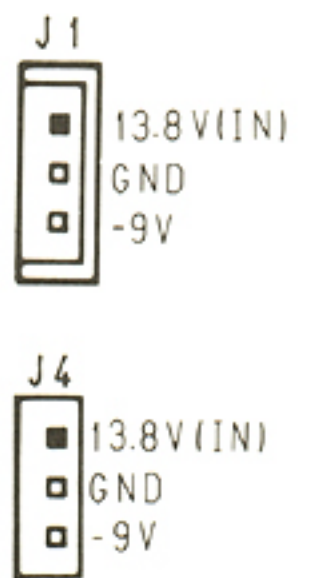
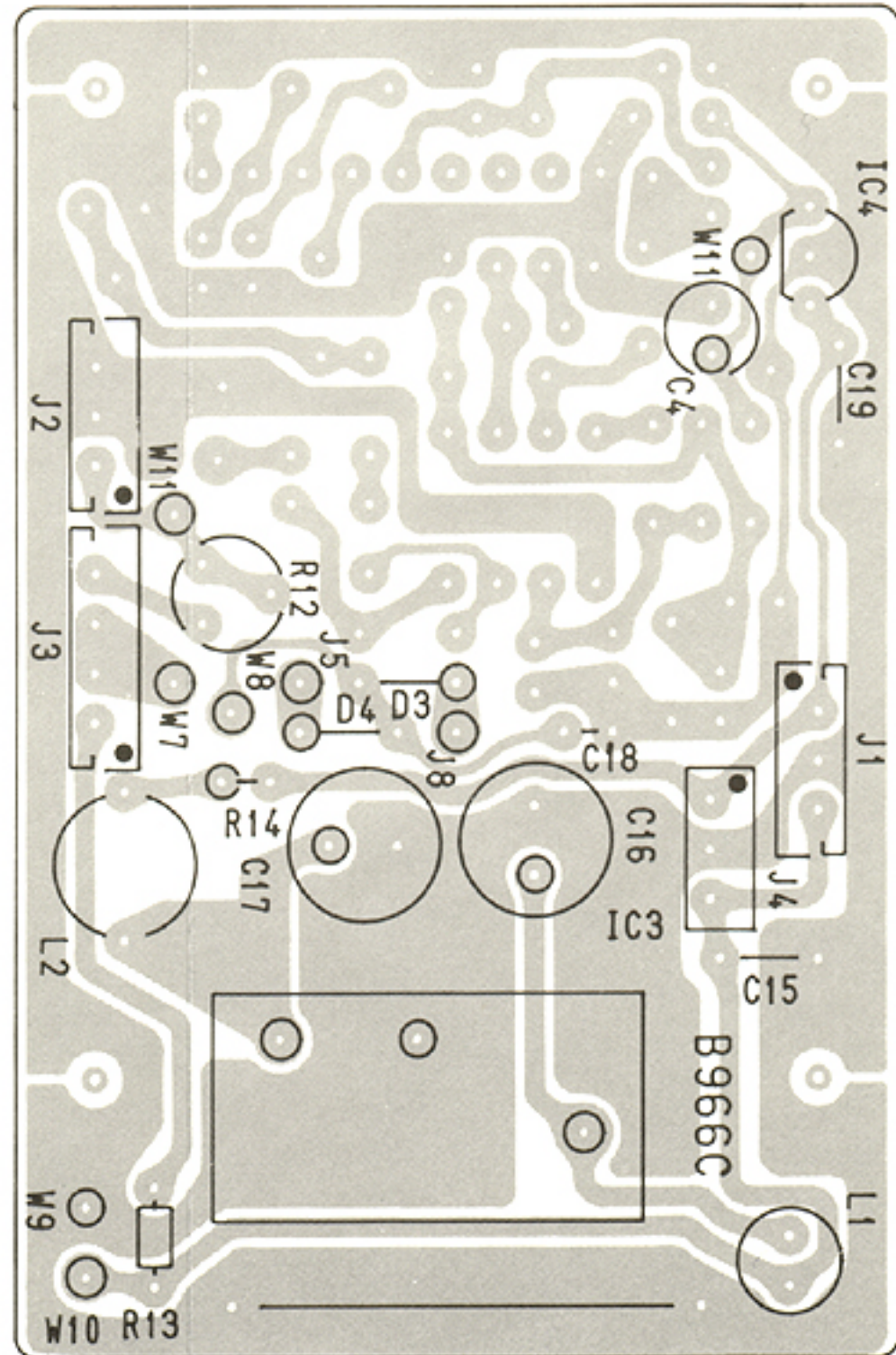

RAM UNIT (On the LOGIC UNIT)

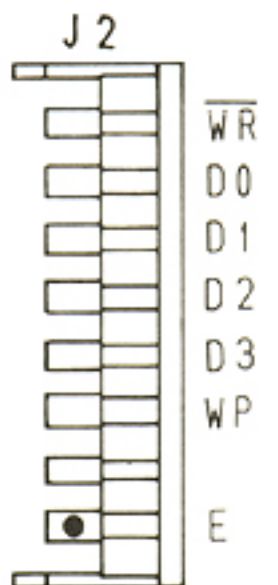
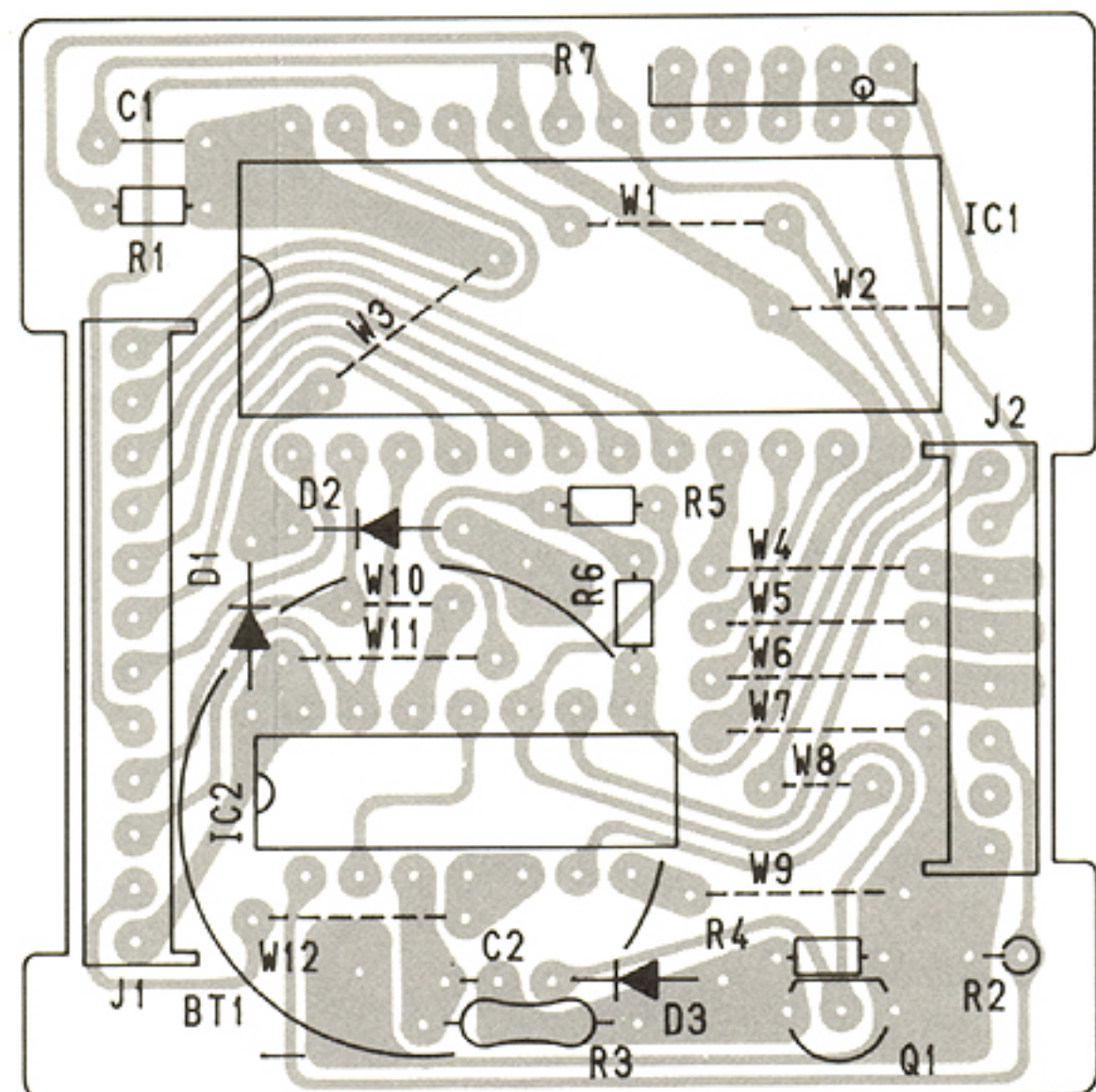
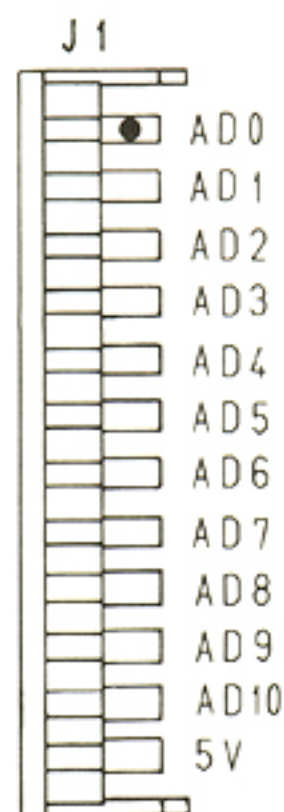
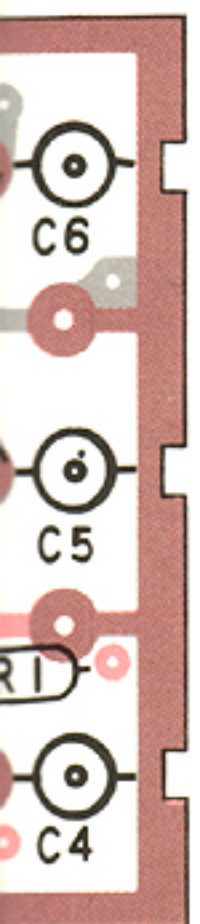

8-7 FILTER UNIT, IF UNIT, RF MIX UNIT

FILTER UNIT

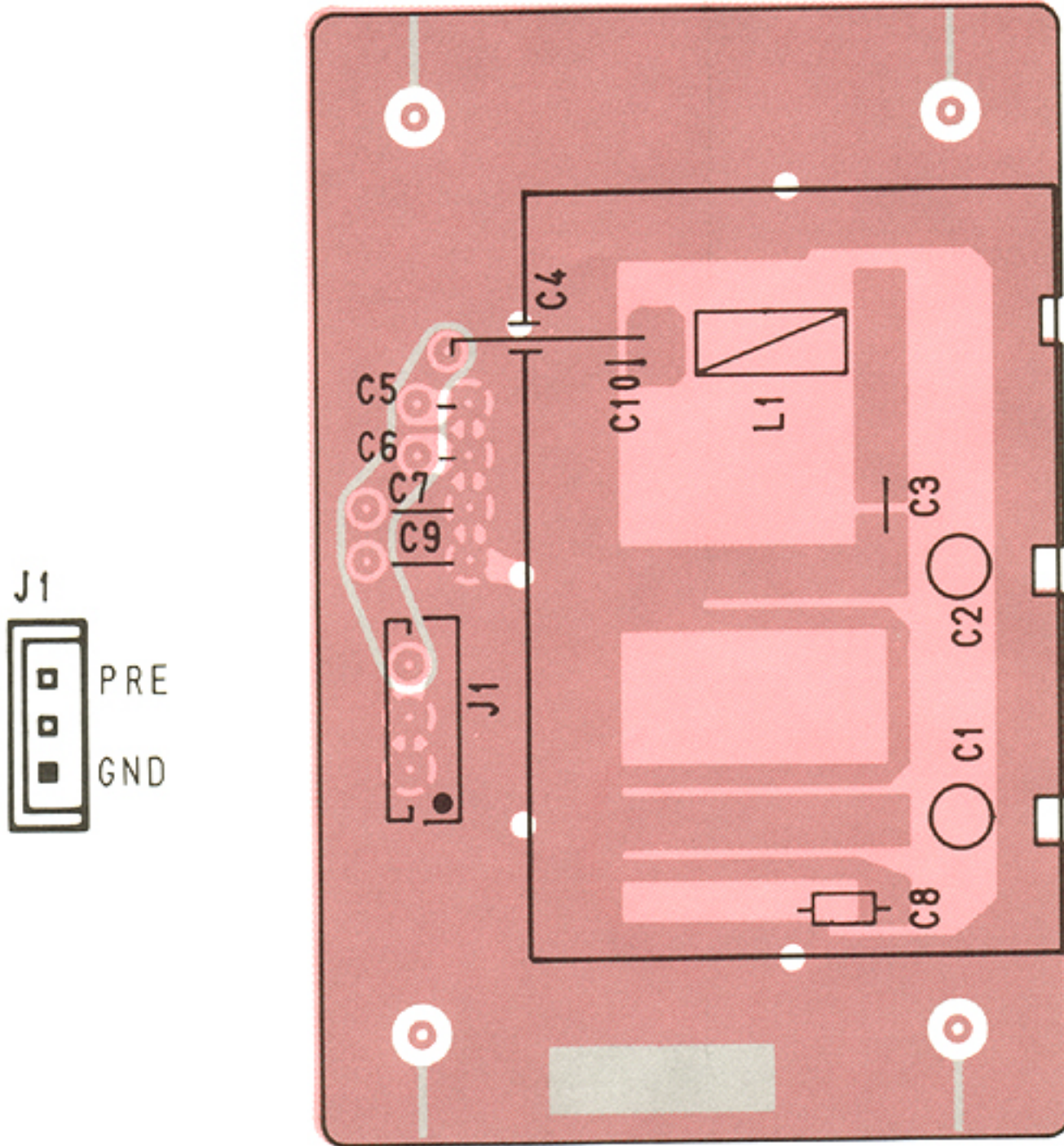

IF UNIT

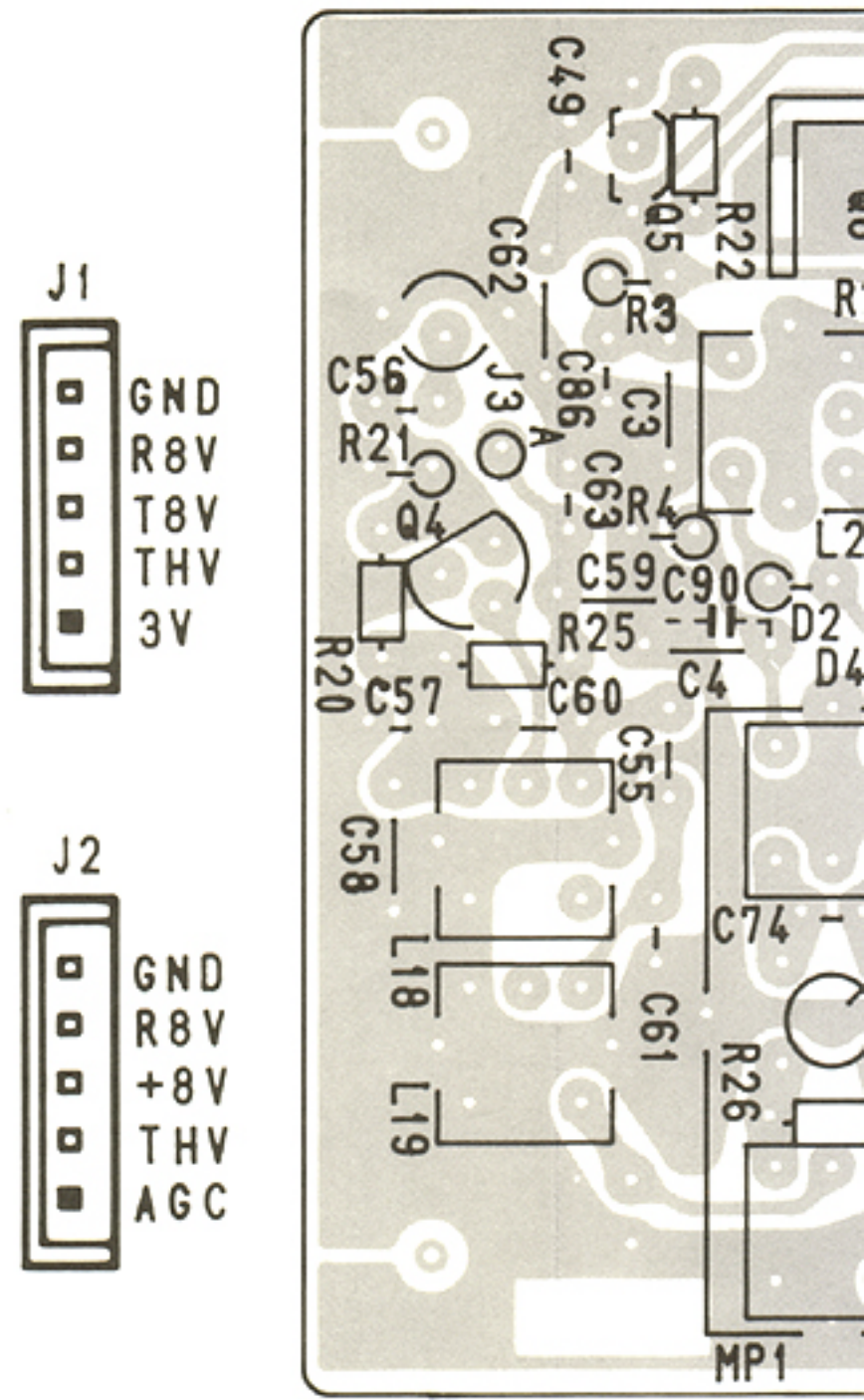

RF MIX UNIT

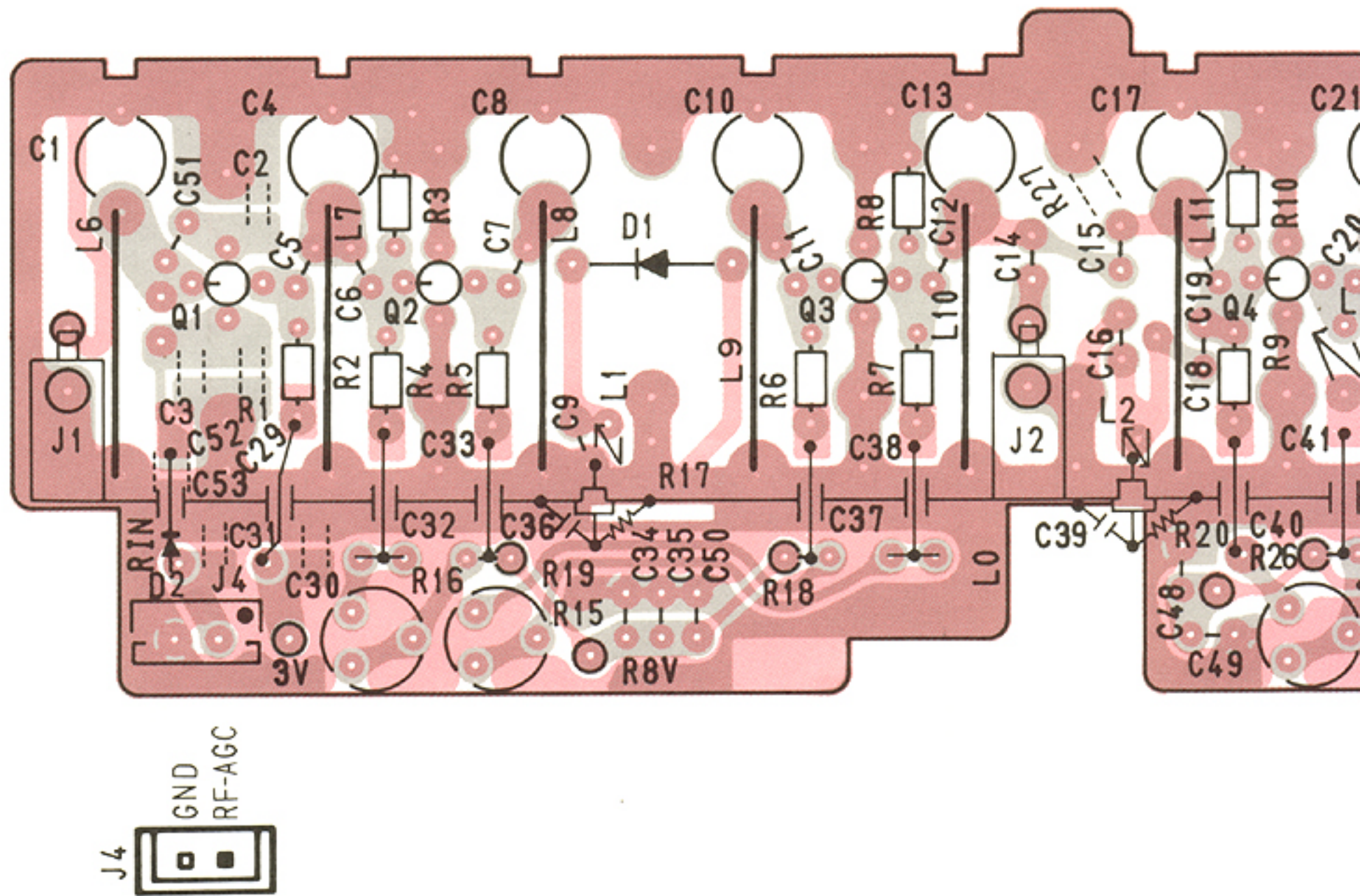

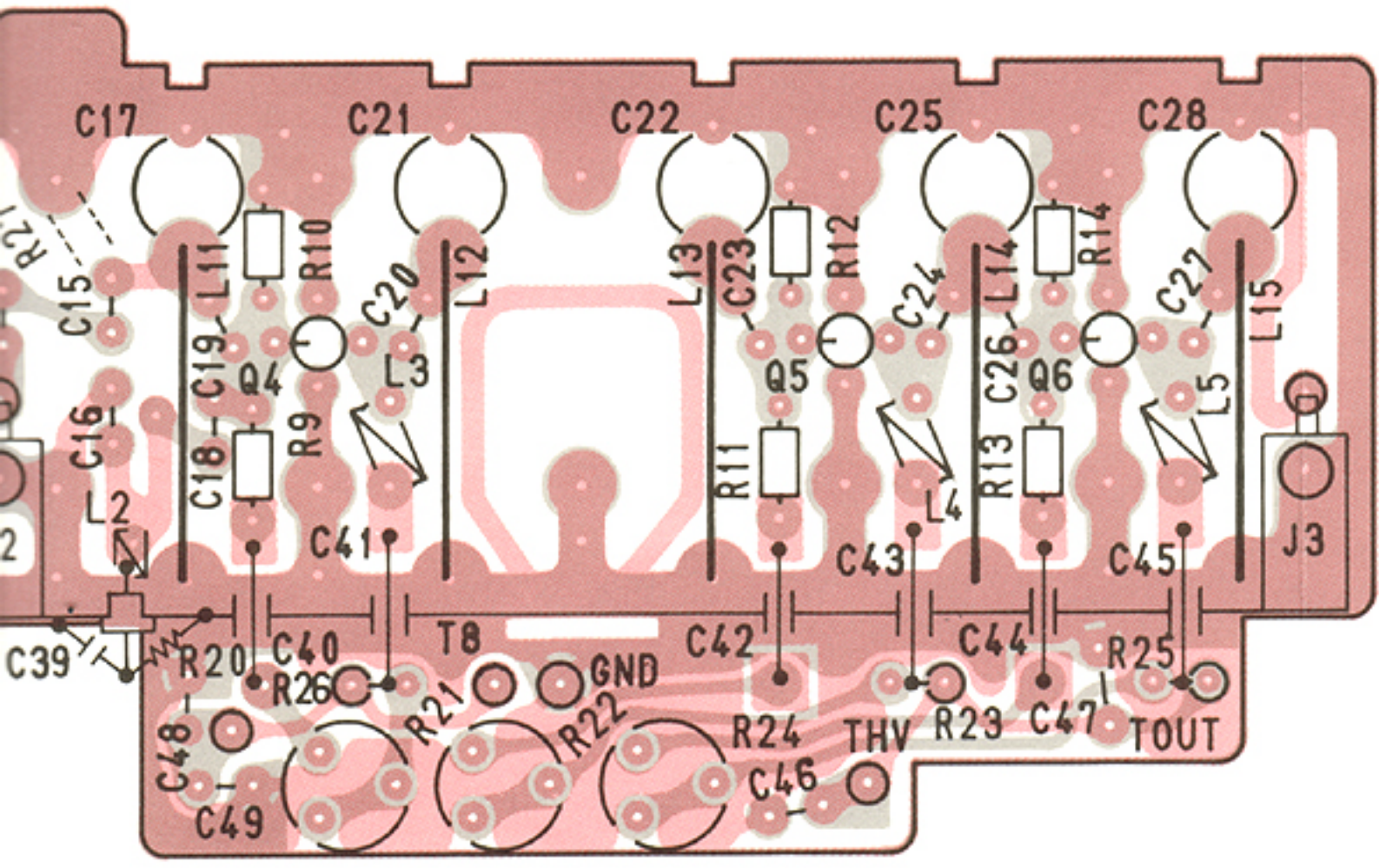
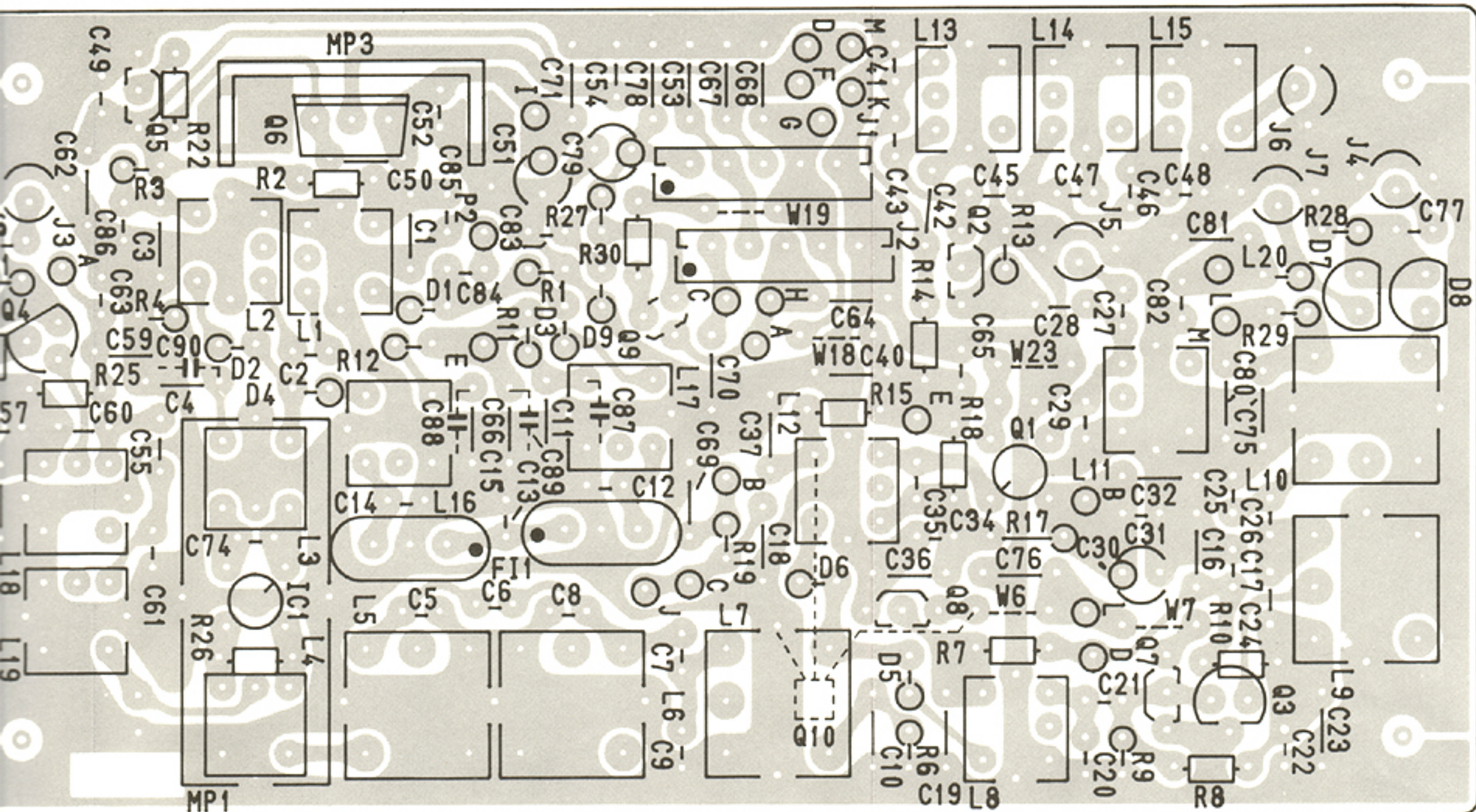

8-8 PA UNIT (MODULE-TYPE)

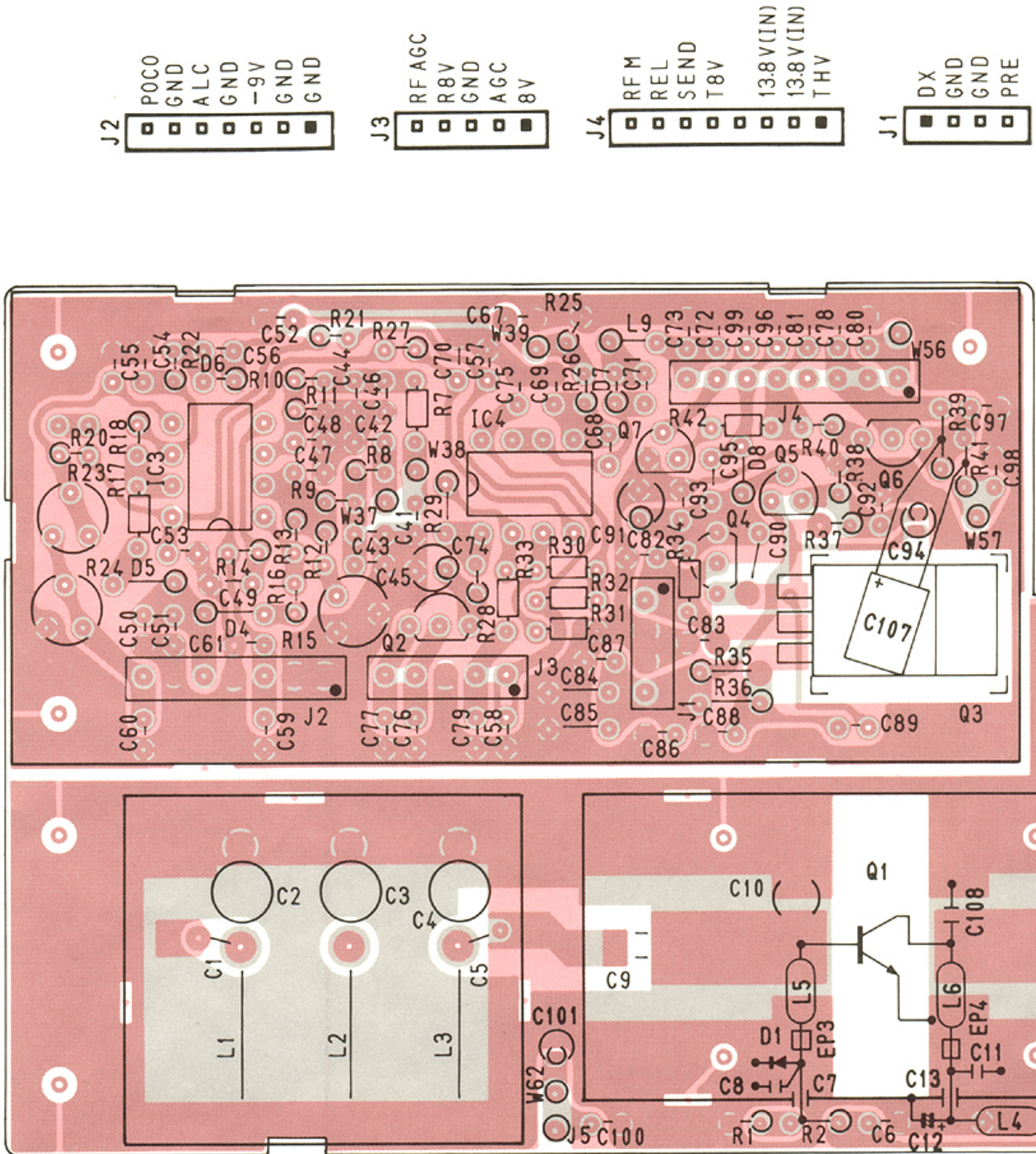

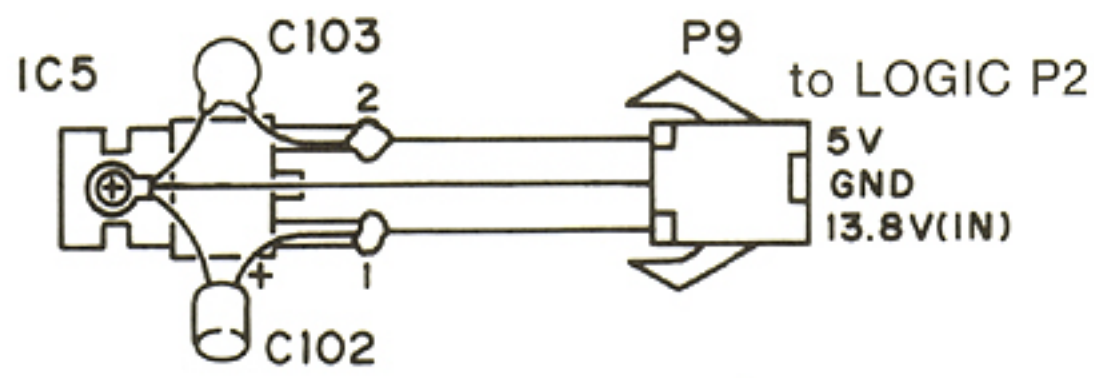
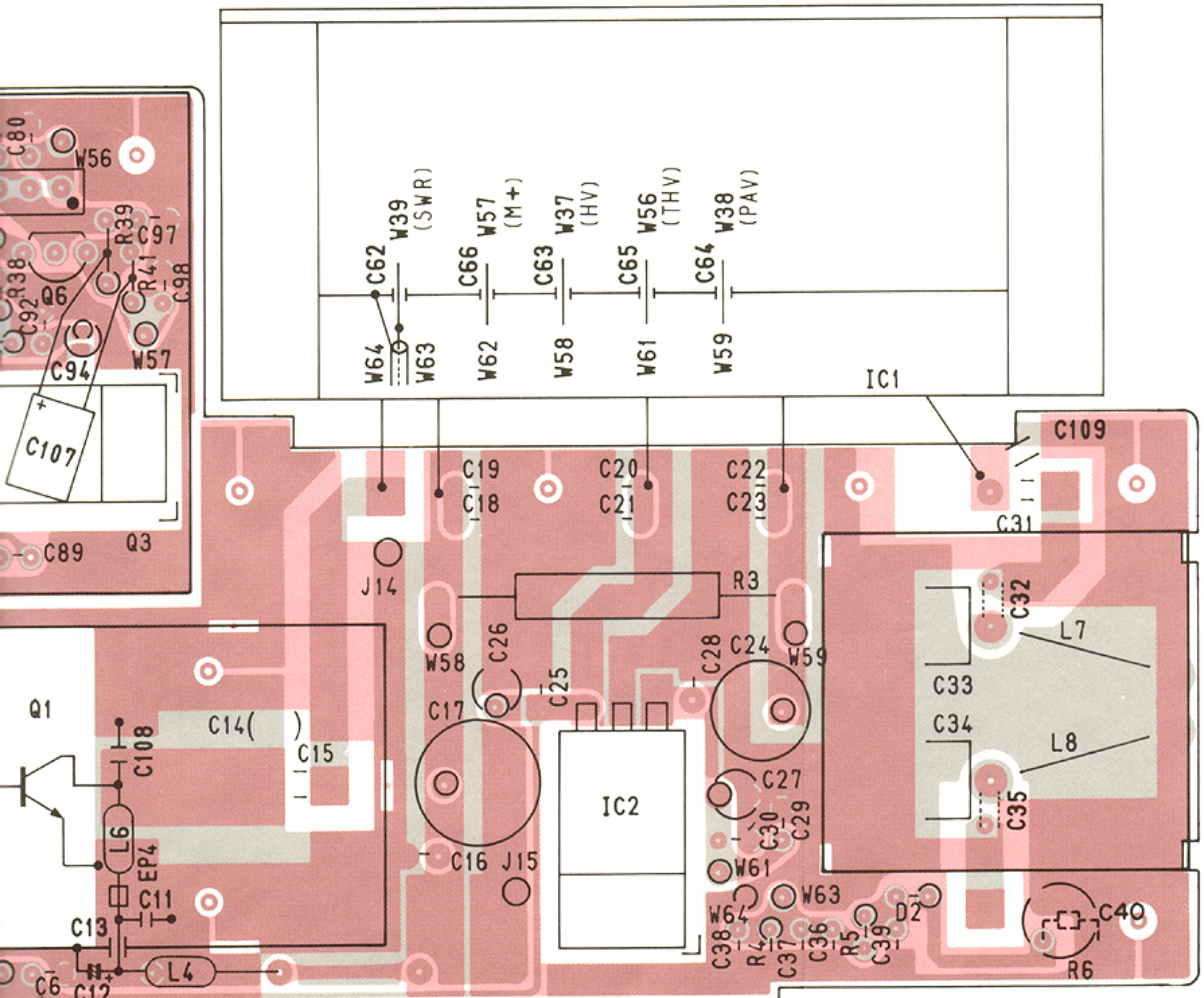
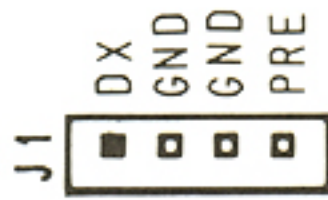

8-9 PA UNIT (TRANSISTOR-TYPE)

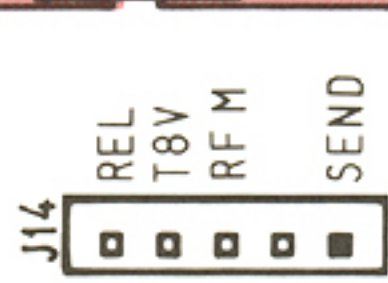
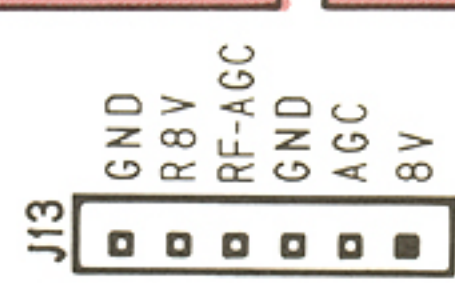
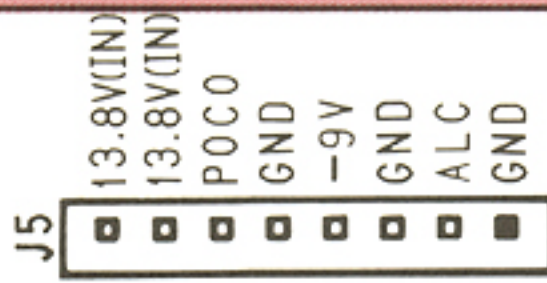
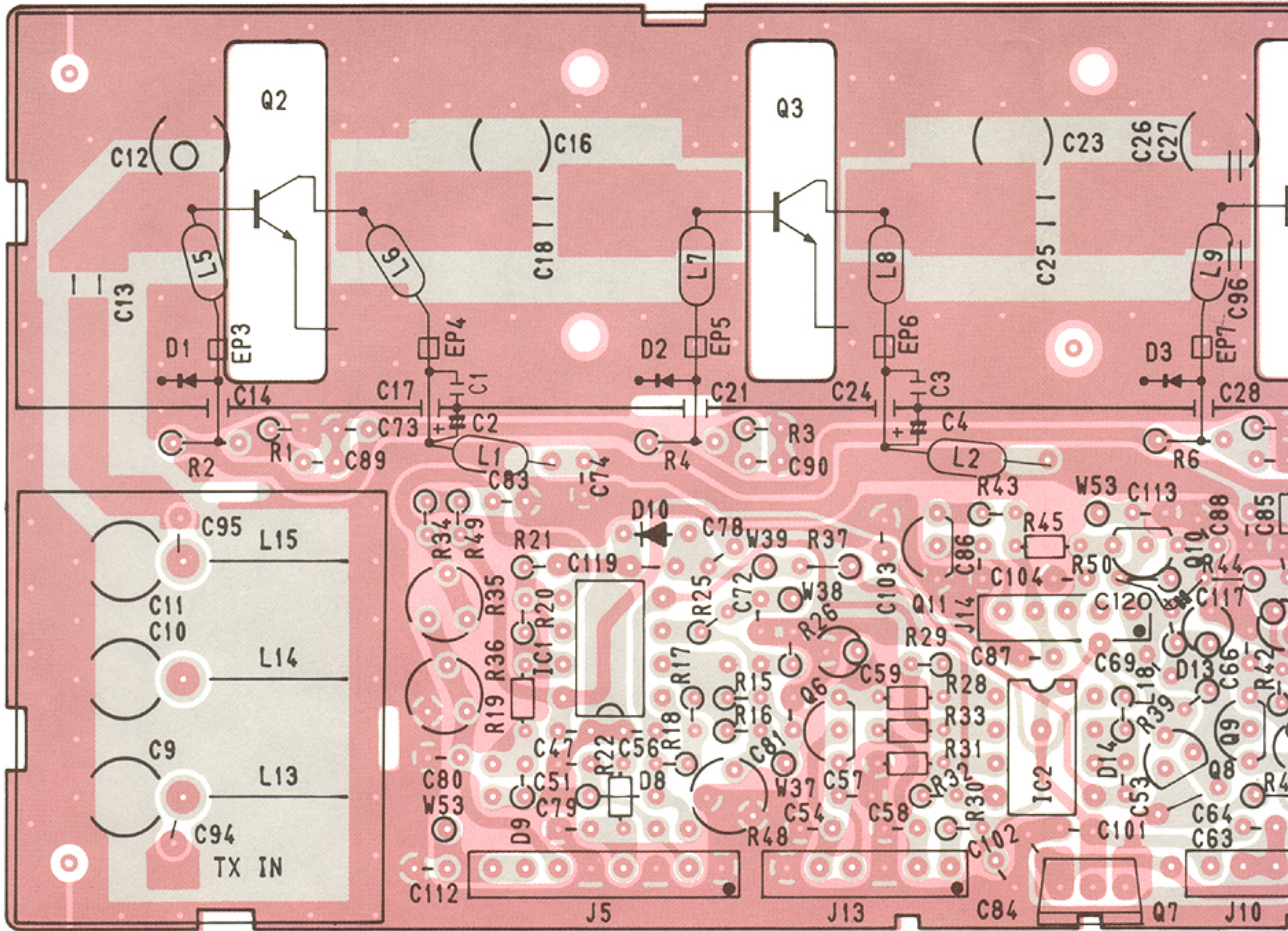

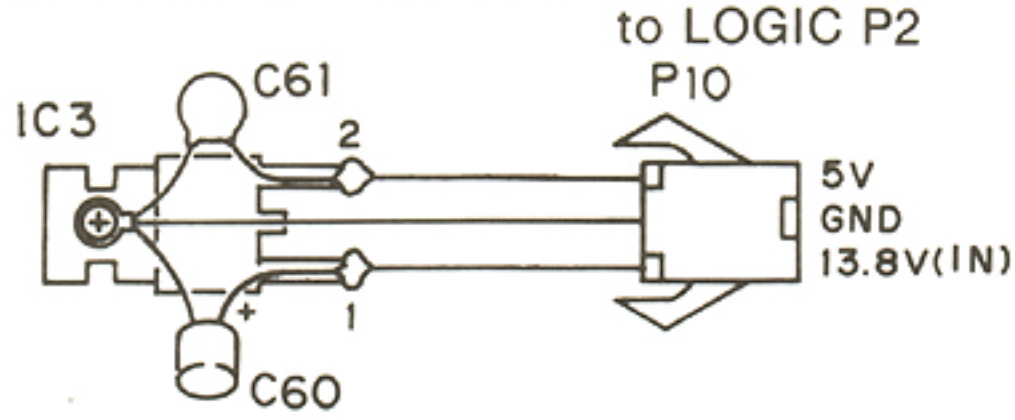
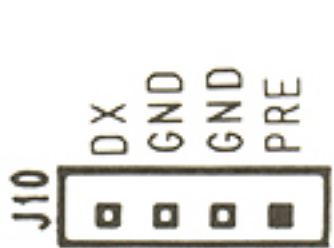
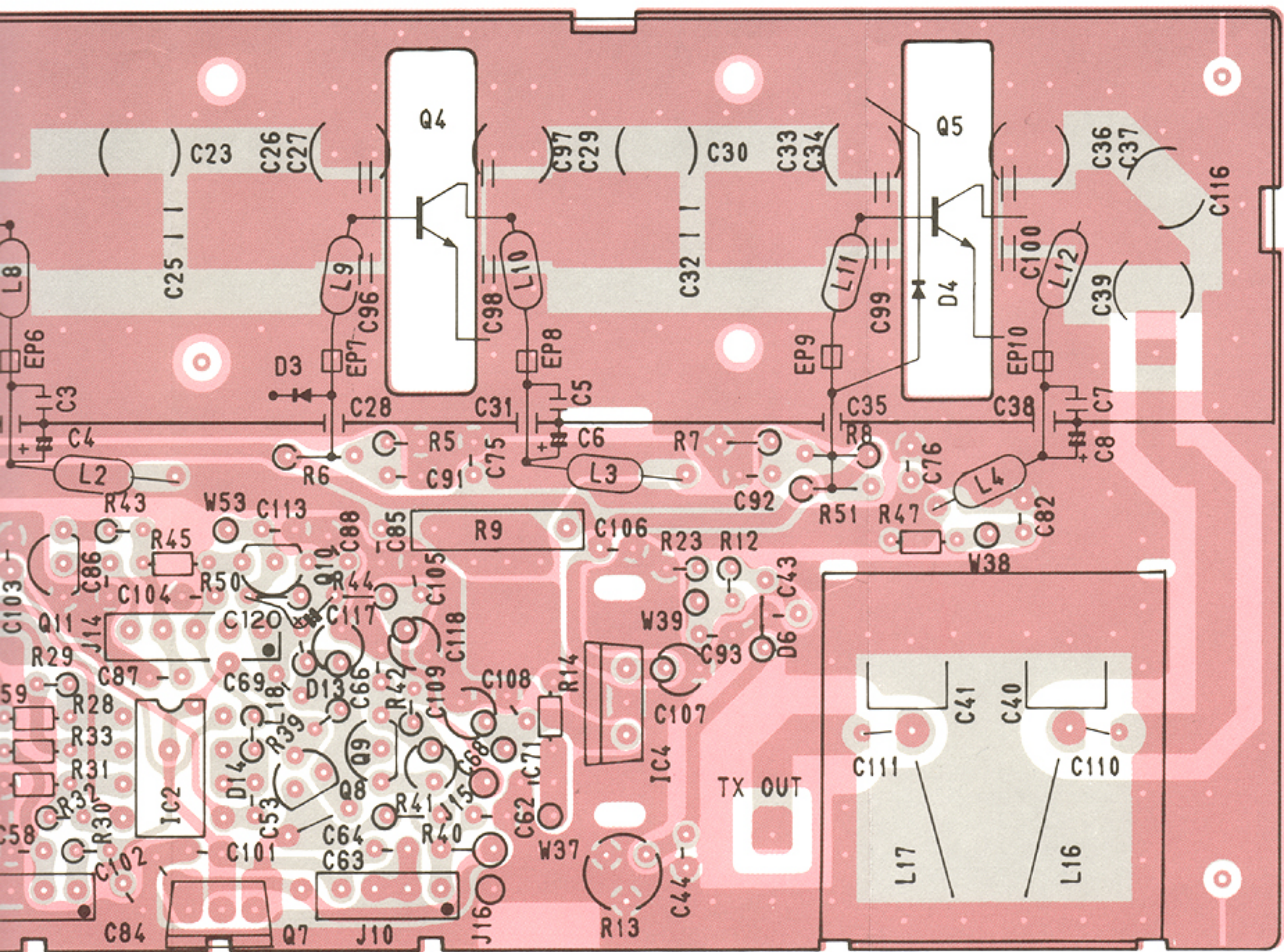

SECTION 9 IC SPECIFICATION

IC	FUNCTION	PAGE
BA401	FM/IF LIMITER	9-2
BA618	LED DRIVER	9-2
NJM4558D	DUAL LOW NOISE AMPLIFIER	9-3
MB-3756	VOLTAGE REGULATOR	9-3
μPC2002	5.4W AUDIO POWER AMPLIFIER	9-3
μPC577H	FM-IF AMPLIFIER	9-4
μPC1037H	DOUBLE-BALANCED MODULATOR	9-4
AN829	DUAL ATTENUATOR	9-4
TC4001	QUAD 2-INPUT POSITIVE NOR GATE	9-5
TC4011	QUAD 2-INPUT POSITIVE NAND GATE	9-5
TC4013	DUAL D-TYPE FLIP FLOP	9-5
TC4071	QUAD 2-INPUT POSITIVE OR GATE	9-5
TC4081	QUAD 2-INPUT POSITIVE AND GATE	9-5
SN74LS02N	QUAD 2-INPUT POSITIVE NOR GATE	9-5
SN74LS08N	QUAD 2-INPUT POSITIVE AND GATE	9-5
SN74LS11N	TRIPLE 3-INPUT POSITIVE AND GATE	9-5
SN74LS74N	DUAL D-TYPE POSITIVE EDGE-TRIGGERED FLIP FLOP WITH SET AND RESET	9-5
SN7404	HEX INVERTERS	9-5
SN7408	QUAD 2-INPUT POSITIVE AND GATE	9-5
SN7432	QUAD 2-INPUT POSITIVE OR GATE	9-5
SN74LS123N	DUAL RETRIGGERABLE MONOSTABLE MULTIVIBRATOR WITH RESET	9-6
SN74LS377N	OCTAL POSITIVE EDGE-TRIGGERED D-TYPE FLIP FLOP WITH ENABLE	9-6
MC-3357	LOW POWER FM IF	9-7
μPD549C	PROGRAMMABLE DISPLAY CONTROLLER	9-7
TC4017	DECADE COUNTER/DIVIDER	9-8
M54466L	1/10, 1/11 DIVIDER	9-8
M54929P	DUAL MODULUS PLL IC	9-9
M50781SP	INPUT/OUTPUT EXPANDER	9-9
S-7116A	PROGRAMMABLE TONE GENERATOR	9-10
TC5082P	OSCILLATOR AND 12 STAGE DIVIDER	9-11
MN1201	C-MOS DUAL 4-BIT DATA LATCHES	9-11
μA7805C	3-TERMINAL 5V REGULATOR	9-12
TA78L008AP	3-TERMINAL POSITIVE VOLTAGE REGULATOR	9-12
TA78L009AP	3-TERMINAL POSITIVE VOLTAGE REGULATOR	9-12
NJM78L05	3-TERMINAL POSITIVE VOLTAGE REGULATOR	9-13
NJM7809A	3-TERMINAL POSITIVE VOLTAGE REGULATOR	9-13
DP-2	DC-DC CONVERTER	9-13
μPD4175 BC	QUAD D-TYPE FLIP FLOP	9-14
M53323P	RETRIGGERABLE MONOSTABLE MULTIVIBRATOR	9-14
ND487C1-3R	DOUBLE-BALANCED MIXER	9-15
SC-1040	1200MHz 10W POWER AMPLIFIER	9-15

BA401 (FM/IF LIMITER)

MAXIMUM RATINGS ($T_a = 25^\circ\text{C}$)

Description	Symbol	Rating	Unit
Supply Voltage	V_{CC}	15	V
Output Voltage	V_{OUT}	24	V
Input Voltage	V_{IN}	± 3	V
Operating Temperature	T_{OPR}	$-25 \sim +75$	$^\circ\text{C}$
Storage Temperature	T_{STG}	$-55 \sim +125$	$^\circ\text{C}$

PIN CONNECTIONS

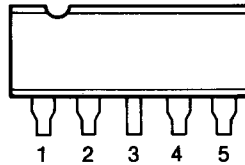

Pin	Function
1	Input
2	Bias
3	GND
4	Output
5	V_{CC}

BA618 (LED DRIVER)

MAXIMUM RATINGS ($T_a = 25^\circ\text{C}$)

Description	Symbol	Rating	Unit
Supply Voltage	V_{CC}	16	V
Power Dissipation	P_O	500 *	mW
Operating Temperature	V_{OPR}	$-20 \sim +75$	$^\circ\text{C}$
Storage Temperature	T_{STG}	$-55 \sim +125$	$^\circ\text{C}$
Drive Current	I_{OUT}	100	mA
Input Voltage	V_{IN}	$-0.5 \sim 16$	V

* $T_a = 25^\circ\text{C}$ (Rating degraded by 5mW for each 1°C increase in T_a .)

BLOCK DIAGRAM/PIN CONNECTIONS

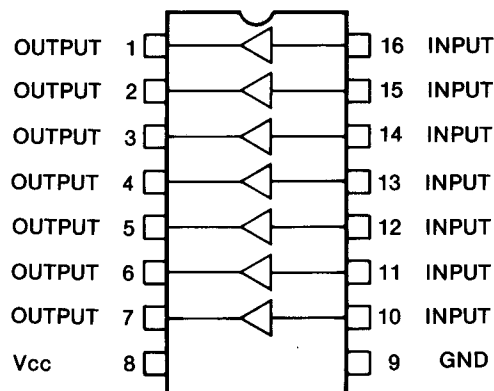

NJM4558D (DUAL LOW NOISE AMPLIFIER)

MAXIMUM RATINGS ($T_a=25^\circ\text{C}$)

Description	Symbol	Rating	Unit
Supply Voltage	V_{DD}	± 18	V
Input Voltage	V_{IN}	± 15	V
Operating Temperature	T_{OPR}	$-20 \sim +75$	$^\circ\text{C}$
Storage Temperature	T_{STG}	$-40 \sim +125$	$^\circ\text{C}$

PIN CONNECTIONS

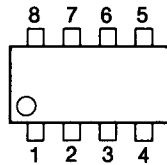

Pin	Function	Pin	Function
1	A Output	5	B+ Input
2	A- Input	6	B- Input
3	A+ Input	7	B Output
4	V_{CC}	8	V_{CC}

MB-3756 (VOLTAGE REGULATOR)

MAXIMUM RATINGS ($T_a=25^\circ\text{C}$)

Description	Symbol	Rating	Unit
Input Voltage	V_{IN}	18	V
Power Dissipation	P_D	1 *1	W
		4 *2	W
Operating Temperature	T_{OPR}	$-20 \sim +75$	$^\circ\text{C}$
Storage Temperature	T_{STG}	$-55 \sim +125$	$^\circ\text{C}$

*1: NO Heat Sink $T_A \leq 70$, *2: Infinite Heat Sink $T_C \leq 70^\circ\text{C}$

PIN CONNECTIONS

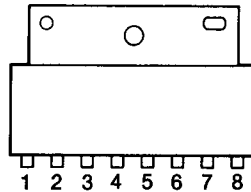

Pin	Function	Pin	Function
1	$V_{OUT(0)}$	5	Control
2	V_{IN}	6	$V_{OUT(1)}$
3	V_{REF}	7	NC
4	Ground	8	$V_{OUT(2)}$

μPC2002 (5.4 W AUDIO POWER AMPLIFIER)

MAXIMUM RATINGS ($T_a=25^\circ\text{C}$)

Description	Symbol	Rating	Unit
Peak Supply Voltage	$V_{CC1(50ms)}$	40	V
Supply Voltage (Quiescent)	V_{CC2}	28	V
Supply Voltage (Operational)	V_{CC3}	18	V
Output Peak Current (Repetitive)	$I_{CC(\text{Peak}) 1}$	3.5	A
Output Peak Current (Non-Repetitive)	$I_{CC(\text{Peak}) 2}$	4.5	A
Power Dissipation	P_D	15 *1	W
Operating Temperature	T_{OPR}	$-30 \sim +75$	$^\circ\text{C}$
Storage Temperature	T_{STG}	$-40 \sim +150$	$^\circ\text{C}$

*1: $T_C=90^\circ\text{C}$

PIN CONNECTIONS

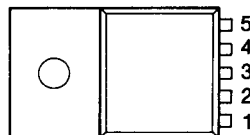

Pin	Function
1	Non-Inverting Input
2	Inverting Input
3	Ground
4	Output
5	V_{CC+}

μPC577H (FM-IF AMPLIFIER)

MAXIMUM RATINGS (Ta = 25°C)

Description	Symbol	Rating	Unit
Supply Voltage	V _{CC}	15	V
Input Voltage	V _{IN}	±3.0	V
Power Dissipation	P _D	300	mW
Operating Temperature	T _{OPR}	-20 ~ +75	°C
Storage Temperature	T _{STG}	-40 ~ +125	°C

PIN CONNECTIONS

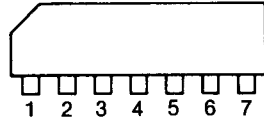

Pin	Function	Pin	Function
1	Bypass Capacitor and Stabilized Voltage	4	Ground
		5	Output
		6	Bypass Capacitor
2	Input High	7	V _{CC}
3	Input Low		

μPC1037H (DOUBLE-BALANCED MODULATOR)

MAXIMUM RATINGS (Ta = 25°C)

Description	Symbol	Rating	Unit
Supply Voltage	V _{CC}	9	V
Power Dissipation	P _D	270	mW
Operating Temperature	T _{OPR}	-30 ~ +75	°C
Storage Temperature	T _{STG}	-40 ~ +125	°C

PIN CONNECTIONS

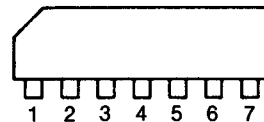

Pin	Function	Pin	Function
1	V _{CC}	5	Signal Input
2	Output 1	6	Bypass
3	Output 2	7	Carrier Input
4	GND		

AN829 (DUAL ATTENUATOR)

MAXIMUM RATINGS (Ta = 25°C)

Description	Symbol	Rating	Unit
Supply Voltage	V _{CC}	18	V
Input Control Voltage	V _C	0 ~ 6	V
Power Dissipation	P _D	450	mW
Operating Temperature	T _{OPR}	-20 ~ +75	°C
Storage Temperature	T _{STG}	-55 ~ +150	°C

PIN CONNECTIONS

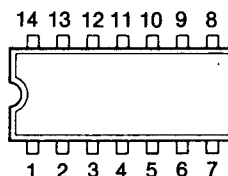

TC4001 (QUAD 2-INPUT POSITIVE NOR GATE)
TC4011 (QUAD 2-INPUT POSITIVE NAND GATE)
TC4013 (DUAL D-TYPE FLIP FLOP)
TC4071 (QUAD 2-INPUT POSITIVE OR GATE)
TC4081 (QUAD 2-INPUT POSITIVE AND GATE)

MAXIMUM RATINGS (Ta = 25°C)

Description	Symbol	Rating	Unit
Supply Voltage	V _{DD}	V _{SS} - 0.5 ~ V _{SS} + 20	V
Input Voltage	V _{IN}	V _{SS} - 0.5 ~ V _{DD} + 0.5	V
Output Voltage	V _{OUT}	V _{SS} - 0.5 ~ V _{DD} + 0.5	V
Input Current	I _{IN}	± 10	mA
Power Dissipation	P _D	300	mW
Storage Temperature	T _{STG}	-65 ~ +150	°C

PIN CONNECTIONS

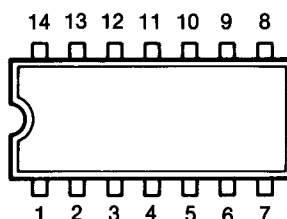

SN74LS02N (QUAD 2-INPUT POSITIVE NOR GATE)
SN74LS08N (QUAD 2-INPUT POSITIVE AND GATE)
SN74LS11N (TRIPLE 3-INPUT POSITIVE AND GATE)
SN74LS74N (DUAL D-TYPE POSITIVE EDGE-TRIGGERED FLIP FLOP WITH SET AND RESET)
SN7404 (HEX INVERTERS)
SN7408 (QUAD 2-INPUT POSITIVE AND GATE)
SN7432 (QUAD 2-INPUT POSITIVE OR GATE)

MAXIMUM RATINGS (Ta = 25°C)

Description	Symbol	Rating	Unit
Supply Voltage	V _{CC}	-0.5 ~ +7	V
Input Voltage	V _{IN}	-0.5 ~ +15	V
Output Voltage*	V _{OUT}	-0.5 ~ V _{CC}	V
Operating Temperature	T _{OPR}	-20 ~ +75	°C
Storage Temperature	T _{STG}	-65 ~ +150	°C

* When the output is HIGH.

PIN CONNECTIONS

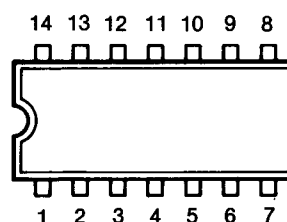

SN74LS123N (DUAL RETRIGGERABLE MONOSTABLE MULTIVIBRATOR WITH RESET)

MAXIMUM RATINGS

Description	Symbol	Rating	Unit
Supply Voltage	V_{CC}	-0.5 ~ +7	V
Input Voltage	V_{IN}	-0.5 ~ +15	V
Output Voltage*	V_{OUT}	-0.5 ~ V_{CC}	V
Operating Temperature	T_{OPR}	-20 ~ +75	°C
Storage Temperature	T_{STG}	-65 ~ +150	°C

* When the output is HIGH.

PIN CONNECTIONS

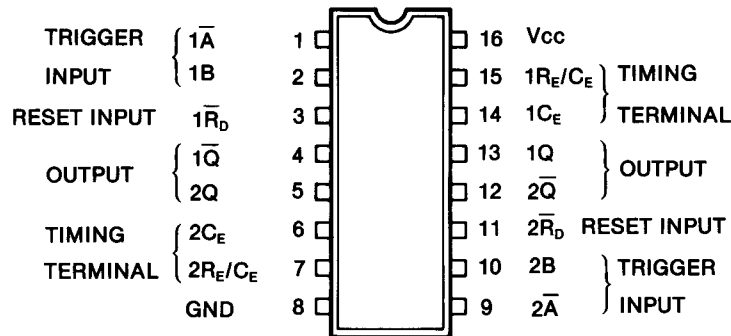

SN74LS377N (OCTAL POSITIVE EDGE-TRIGGERED D-TYPE FLIP FLOP WITH ENABLE)

MAXIMUM RATINGS

Description	Symbol	Rating	Unit
Supply Voltage	V_{CC}	-0.5 ~ +7	V
Input Voltage	V_{IN}	-0.5 ~ +15	V
Output Voltage*	V_{OUT}	-0.5 ~ V_{CC}	V
Operating Temperature	T_{OPR}	-20 ~ +75	°C
Storage Temperature	T_{STG}	-65 ~ +150	°C

* When the output is HIGH.

PIN CONNECTIONS

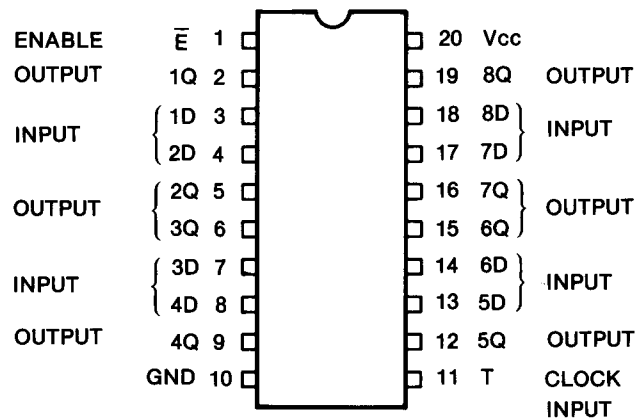

MC-3357 (LOW POWER FM IF)

MAXIMUM RATINGS ($T_a = 25^\circ\text{C}$)

Description	Symbol	Rating	Unit
Supply Voltage (Maximum)	V_{CC}	12	V
Supply Voltage	V_{CC}	4~8	V
Input Voltage	V_{IN}	1.0	V_{RMS}
Operating Temperature	T_{OPR}	-30~+70	$^\circ\text{C}$
Storage Temperature	T_{STG}	-65~+150	$^\circ\text{C}$

PIN CONNECTIONS

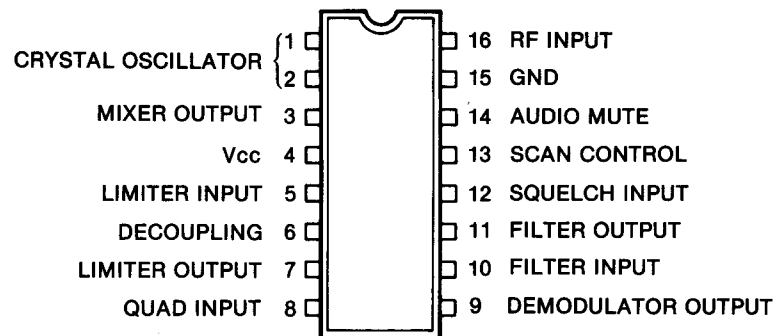

μ PD549C (PROGRAMMABLE DISPLAY CONTROLLER)

MAXIMUM RATINGS ($T_a = 25^\circ\text{C}$)

Description	Symbol	Rating	Unit
Supply Voltage	V_{GG}	-15~+0.3	V
Input Voltage	V_{IN}	-20~+0.3	V
Output Voltage	V_{OUT}	-42~+0.3	V
Operating Temperature	T_{OPR}	-10~+70	$^\circ\text{C}$
Storage Temperature	T_{STG}	-40~+125	$^\circ\text{C}$

PIN CONNECTIONS

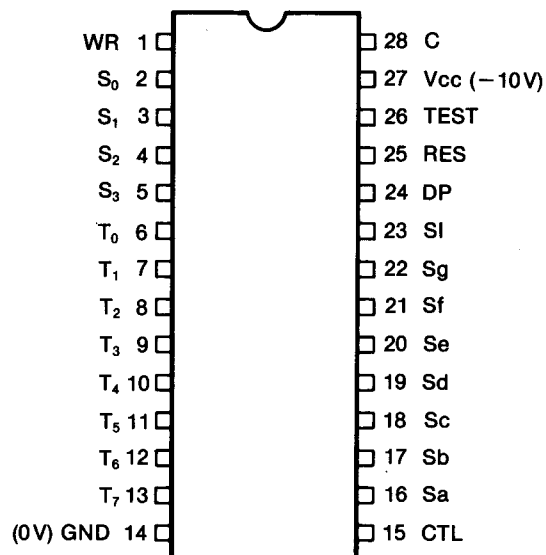

TC4017 (DECADE COUNTER/DIVIDER)

MAXIMUM RATINGS

Description	Symbol	Rating	Unit
Supply Voltage	V_{DD}	$V_{SS} - 0.5 \sim V_{SS} + 20$	V
Input Voltage	V_{IN}	$V_{SS} - 0.5 \sim V_{DD} + 0.5$	V
Output Voltage	V_{OUT}	$V_{SS} - 0.5 \sim V_{DD} + 0.5$	V
Input Current	I_{IN}	± 10	mA
Power Dissipation	P_D	300 (DIP)/180 (MFP)	mW
Operating Temperature	T_{OPR}	$-40 \sim +85$	$^{\circ}\text{C}$
Storage Temperature	T_{STG}	$-65 \sim +150$	$^{\circ}\text{C}$

PIN CONNECTIONS

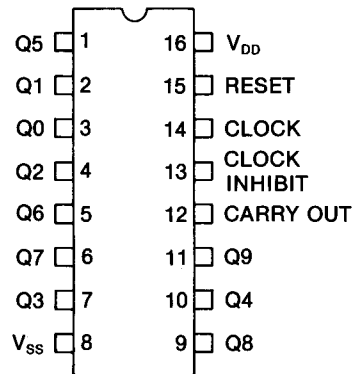

M54466L (1/10, 1/11 DIVIDER)

MAXIMUM RATINGS

Description	Symbol	Rating	Unit
Supply Voltage	V_{CC}	$-0.5 \sim 7$	V
Input Voltage	V_{IN}	2	V
Output Voltage	V_{OUT}	3	V
Power Dissipation	P_D	500*	mW
Operating Temperature	T_{OPR}	$-20 \sim +70$	$^{\circ}\text{C}$
Storage Temperature	T_{STG}	$-40 \sim +125$	$^{\circ}\text{C}$

* $T_a = 75^{\circ}\text{C}$

PIN CONNECTIONS

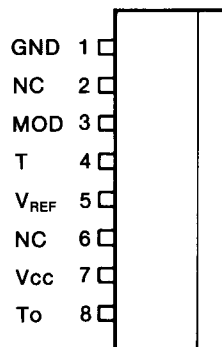

M54929P (DUAL MODULUS PLL IC)

MAXIMUM RATINGS

Description	Symbol	Rating	Unit
Supply Voltage	V_{CC}	-0.5~6	V
Input Voltage	V_{IN}	-0.5~6	V
Output Voltage	V_{OUT}	V_{CC}	V
Power Dissipation	P_D	600	mW
Operating Temperature	T_{OPR}	-20~+75	°C
Storage Temperature	T_{STG}	-40~+125	°C

PIN CONNECTIONS

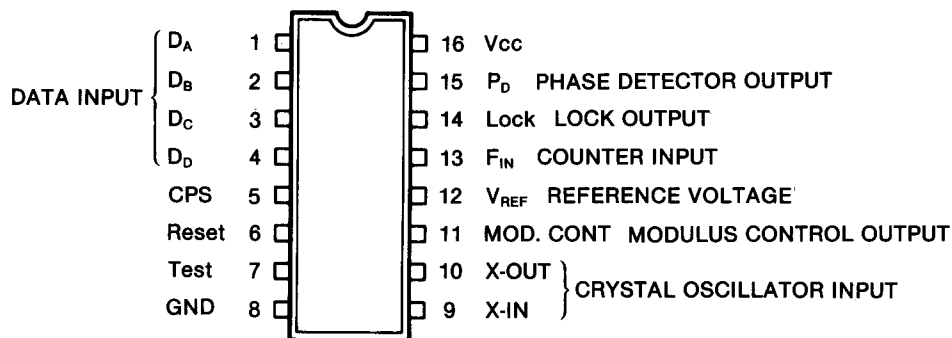

M50781SP (INPUT/OUTPUT EXPANDER)

MAXIMUM RATINGS

Description	Symbol	Rating	Unit
Supply Voltage	V_{DD}	-0.3~15	V
Input Voltage	V_{IN}	$V_{SS}-0.3\sim V_{DD}+0.3$	V
Output Voltage	V_{OUT}	$V_{SS}-0.3\sim V_{DD}+0.3$	V
Power Dissipation	P_D	600	mW
Operating Temperature	T_{OPR}	-10~+70	°C
Storage Temperature	T_{STG}	-40~+125	°C

PIN CONNECTIONS

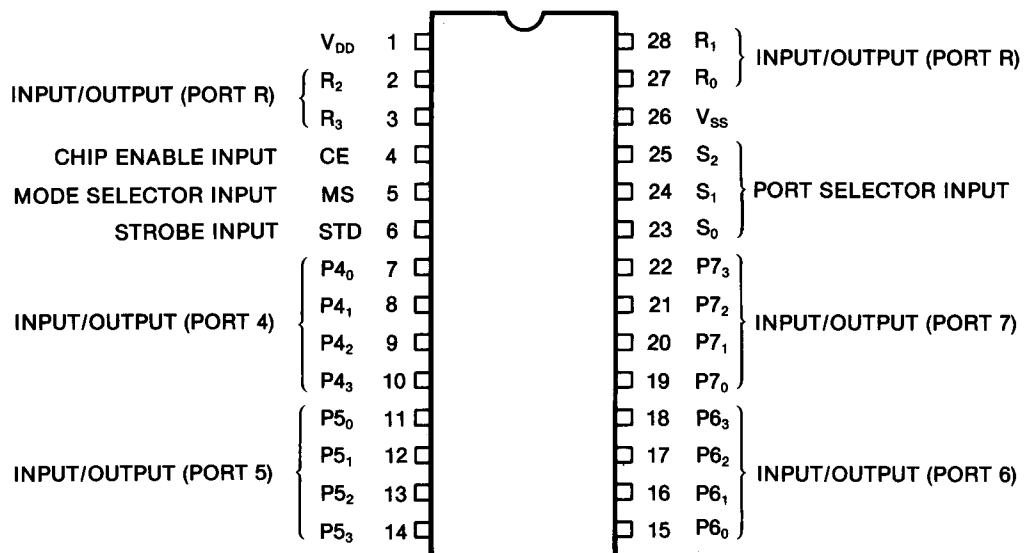

S-7116A (PROGRAMMABLE TONE GENERATOR)

MAXIMUM RATINGS

Description	Symbol	Rating	Unit
Supply Voltage	V_{DD}	12.0	V
Input Voltage	V_{IN}	$V_{SS} - 0.3 \sim V_{DD} + 0.3$	V
Output Voltage	V_{OUT}	$V_{SS} - 0.3 \sim V_{DD} + 0.3$	V
Power Dissipation	P_D	300	mW
Operating Temperature	T_{OPR}	-25 ~ +70	°C
Storage Temperature	T_{STG}	-40 ~ +125	°C

PIN CONNECTIONS/BLOCK DIAGRAM

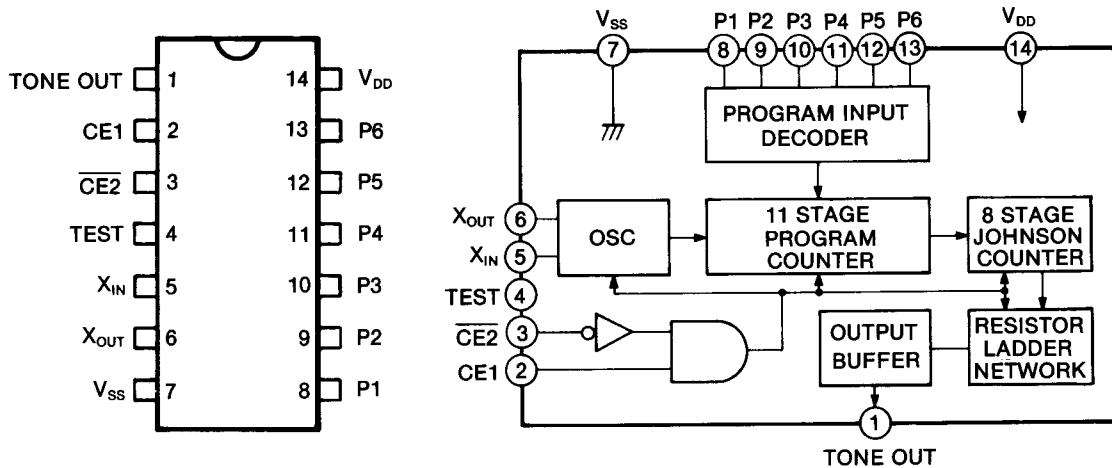

PROGRAMMING TABLE

TONE FREQ.	P1	P2	P3	P4	P5	P6	TONE FREQ.	P1	P2	P3	P4	P5	P6	TONE FREQ.	P1	P2	P3	P4	P5	P6
67.0	1						136.5	1	1		1			500	1	1	1			1
71.9		1					141.3		1	1		1		600				1		1
74.4	1	1					146.2	1	1	1		1		700	1			1		1
77.0			1				151.4				1	1		800		1		1		1
79.7	1		1				156.7	1			1	1		900	1	1		1		1
82.5		1	1				162.2		1		1	1		1000			1	1		1
85.4	1	1	1				167.9	1	1		1	1		1600	1		1	1		1
88.5				1			173.8			1	1	1		1700		1	1	1		1
91.5	1			1			179.9	1		1	1	1		1750	1	1	1	1		1
94.8		1		1			186.2		1	1	1	1		1800					1	1
97.4	1	1		1			192.8	1	1	1	1	1		1300	1				1	1
100.0			1	1			203.5					1		2000		1			1	1
103.5	1		1	1			210.7	1				1		2200	1	1			1	1
107.2		1	1	1			218.1		1			1		2975			1		1	1
110.9	1	1	1	1			225.7	1	1			1		2550	1		1		1	1
114.8					1		233.6			1		1		2295		1	1		1	1
118.8	1				1		241.8	1		1		1		2125	1	1	1		1	1
123.0		1			1		250.3		1	1		1		1275				1	1	1
127.3	1	1			1									1445	1			1	1	1
131.8			1		1															

NOTE) 1 : V_{DD}
 Blank : Ground or Open
 Crystal frequency : 3.579545 MHz

TC5082P (OSCILLATOR AND 12 STAGE DIVIDER)

MAXIMUM RATINGS

Description	Symbol	Rating	Unit
Supply Voltage	V_{DD}	10	V
Input Voltage	V_{IN}	$-0.3 \sim V_{DD} + 0.3$	V
Operating Temperature	T_{OPR}	$-30 \sim +75$	$^{\circ}\text{C}$
Storage Temperature	T_{STG}	$-55 \sim +125$	$^{\circ}\text{C}$

PIN CONNECTIONS

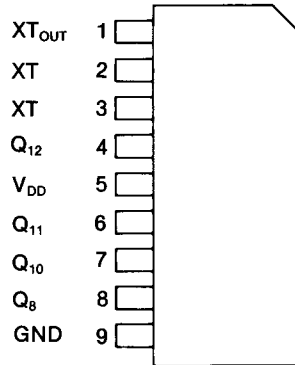

Pin No.	8	7	6	4	1
Pin Name	Q_8	Q_{10}	Q_{11}	Q_{12}	XT_{OUT}
Division Ratio	1/256	1/1024	1/2048	1/4096	1/1

MN1201 (C-MOS DUAL 4-BIT DATA LATCHES)

MAXIMUM RATINGS ($V_{SS}=0\text{V}$, $T_a=25^{\circ}\text{C}$)

Description	Symbol	Rating	Unit
Supply Voltage	V	$-0.3 \sim +8$	V
Input Voltage	V_{IN}	$-0.3 \sim V_{DD} + 0.3$	V
Output Voltage	V_{OUT}	$-0.3 \sim V_{DD} + 0.3$	V
Operating Temperature	T_{OPR}	$-30 \sim +70$	$^{\circ}\text{C}$
Storage Temperature	T_{STG}	$-55 \sim +100$	$^{\circ}\text{C}$

PIN CONNECTIONS

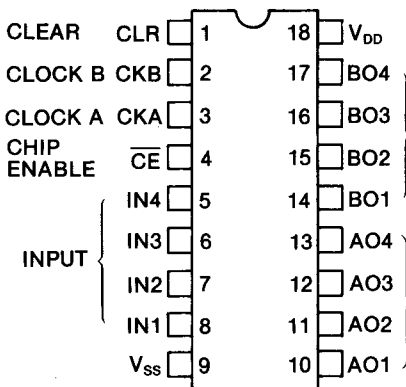

BLOCK DIAGRAM

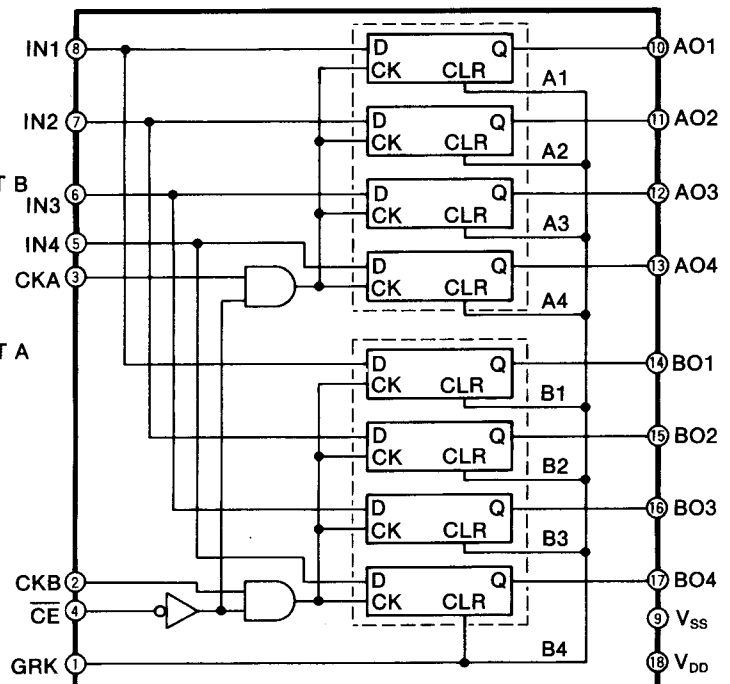

μA7805C (3-TERMINAL 5V REGULATOR)

MAXIMUM RATINGS ($T_a = 25^\circ\text{C}$)

Description	Symbol	Rating	Unit
Input Voltage	V_{IN}	35	V
Power Dissipation	P_D	Internally Limited	W
Operating Temperature	T_{OPR}	$-30 \sim +75$	$^\circ\text{C}$
Storage Temperature	T_{STG}	$-65 \sim +150$	$^\circ\text{C}$

PIN CONNECTIONS

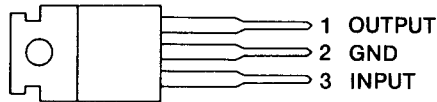

TA78L008AP (3-TERMINAL POSITIVE VOLTAGE REGULATOR)

MAXIMUM RATINGS

Description	Symbol	Rating	Unit
Input Voltage	V_{IN}	35	V
Output Voltage	V_{OUT}	8	V
Power Dissipation	P_D	800	mW
Operating Temperature	T_{OPR}	$-30 \sim +75$	$^\circ\text{C}$
Storage Temperature	T_{STG}	$-55 \sim +150$	$^\circ\text{C}$

PIN CONNECTIONS

(Bottom View)

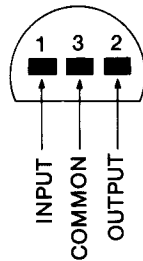

TA78L009AP (3-TERMINAL POSITIVE VOLTAGE REGULATOR)

MAXIMUM RATINGS

Description	Symbol	Rating	Unit
Input Voltage	V_{IN}	35	V
Output Voltage	V_{OUT}	9.36	V
Power Dissipation	P_D	800	mW
Operating Temperature	T_{OPR}	$-30 \sim +75$	$^\circ\text{C}$
Storage Temperature	T_{STG}	$-55 \sim +150$	$^\circ\text{C}$

PIN CONNECTIONS

(Bottom View)

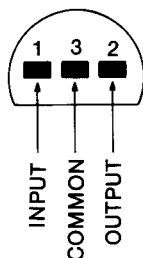

NJM78L05 (3-TERMINAL POSITIVE VOLTAGE REGULATOR)

MAXIMUM RATINGS

Description	Symbol	Rating	Unit
Input Voltage	V_{IN}	30	V
Output Voltage	V_{OUT}	5.25	V
Power Dissipation	P_D	500	mW
Operating Temperature	T_{OPR}	-30 ~ +75	°C
Storage Temperature	T_{STG}	-40 ~ +125	°C

PIN CONNECTIONS

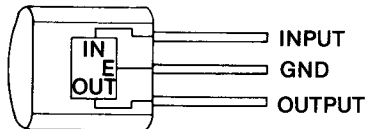

NJM7809A (3-TERMINAL POSITIVE VOLTAGE REGULATOR)

MAXIMUM RATINGS

Description	Symbol	Rating	Unit
Input Voltage	V_{IN}	15	V
Output Voltage	V_{OUT}	9	V
Power Dissipation	P_D	16 ($T_C \leq 45^\circ\text{C}$)	W
Operating Temperature	T_{OPR}	-30 ~ +75	°C
Storage Temperature	T_{STG}	-40 ~ +125	°C

PIN CONNECTIONS



DP-2 (DC-DC CONVERTER)

MAXIMUM RATINGS

Description	Symbol	Rating	Unit
Input Voltage	V_{IN}	+10 ~ +18	V
Output Voltage	V_{OUT}	10.16	V
Output Current	I_o	100	mA

PIN CONNECTIONS

(Bottom View)

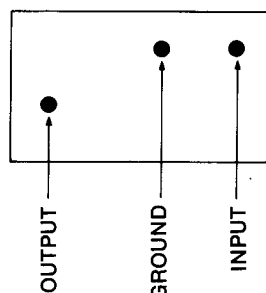

μPD4175BC (QUAD D-TYPE FLIP FLOP)

MAXIMUM RATINGS

Description	Symbol	Rating	Unit
Supply Voltage	V_{DD}	$V_{SS} - 0.5 \sim V_{SS} + 20$	V
Input Voltage	V_{IN}	$V_{SS} - 0.5 \sim V_{DD} + 0.5$	V
Output Voltage	V_{OUT}	$V_{SS} - 0.5 \sim V_{DD} + 0.5$	V
Input Current	I_{IN}	± 10	mA
Power Dissipation	P_D	300 (DIP)/180 (MFP)	mW
Operating Temperature	T_{OPR}	$-40 \sim +85$	°C
Storage Temperature	T_{STG}	$-65 \sim +150$	°C

PIN CONNECTIONS

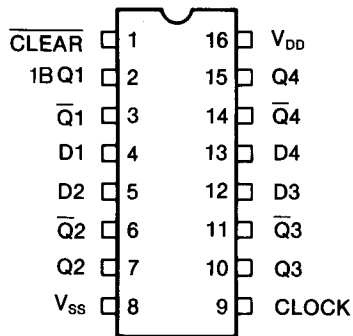

M53323P (RETRIGGERABLE MONOSTABLE MULTIVIBRATOR)

MAXIMUM RATINGS

Description	Symbol	Rating	Unit
Supply Voltage	V_{CC}	5.25	V
High-Level Input Voltage	V_{IH}	2 (minimum)	V
Low-Level Input Voltage	V_{IL}	0.8	V
High-Level Output Voltage	V_{OH}	3.4	V
Low-Level Output Voltage	V_{OL}	0.4	V
Operating Temperature	T_{OPR}	$-20 \sim +75$	°C

PIN CONNECTIONS/BLOCK DIAGRAM

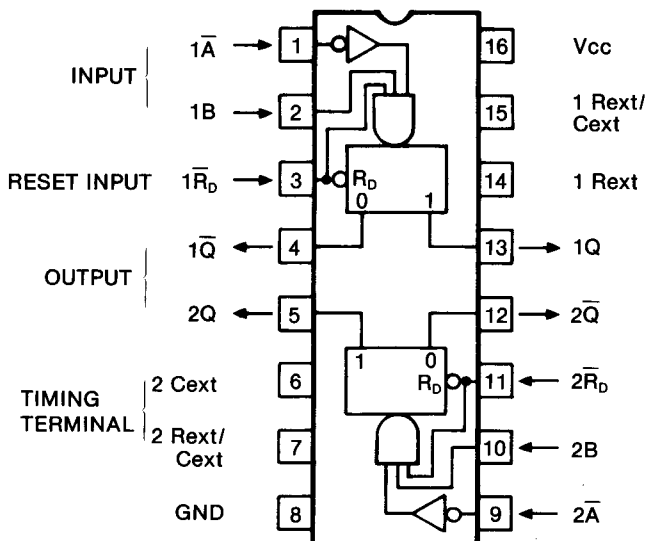

FUNCTION TABLE

\bar{A}	B	\bar{R}_b	Q	\bar{Q}
X	X	L	L	H
H	X	X	L	H
X	L	X	L	H
L		H		
	H	H		
L	H			

ND487C1-3R (DOUBLE-BALANCED MIXER)

MAXIMUM RATINGS

Description	Symbol	Rating	Unit
Junction Temperature	T_J	+150	°C
Storage Temperature	T_{STG}	-65 ~ +150	°C

PIN CONNECTIONS

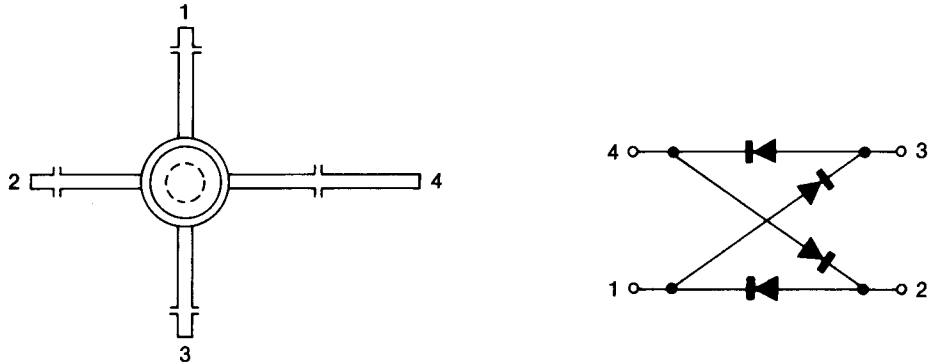

SC-1040 (1200 MHz 10 W POWER AMPLIFIER)

MAXIMUM RATINGS ($T_a = 25^\circ\text{C}$)

Description	Symbol	Rating	Unit
Supply Voltage	V_{CC}	17	V
Input Power	P_{IN}	2	W
Output Power	P_{OUT}	25	W
Operating Temperature	T_{OPR}	-30 ~ +110	°C
Storage Temperature	T_{STG}	-40 ~ +110	°C

PIN CONNECTIONS

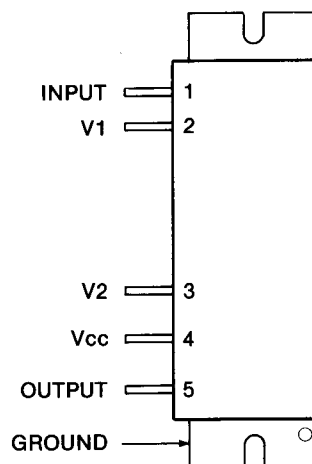

SECTION 10 PARTS LIST

[FRONT UNIT]

REF. NO.	DESCRIPTION	PART NO.
Q1	Transistor	2SA798 G
Q2	Transistor	2SC945 P
Q3	Transistor	2SC945 P
Q4	Transistor	2SA1015
Q5	Transistor	2SC945 P
Q6	Transistor	2SA1015
Q7	Transistor	2SC945 P
Q8	Transistor	2SC945 P
Q9	Transistor	2SC945 P
Q10	Transistor	2SC945 P
Q11	Transistor	2SA1015
Q12	Transistor	2SC3399
Q13	Transistor	2SC3399
Q14	Transistor	2SC3402 (#02 only)
Q15	Transistor	2SC1571 G
Q16	Transistor	2SC2785 EF
Q17	Transistor	2SA933X S
D1	Diode	1SS53
D2	LED	SLB-22 UR
D3	LED	SLB-22 GG
D4	Diode	1SS53
D5	Diode	1SS53
D6	Diode	1SS53
D7	Diode	1SS53
D8	Diode	1SS53
D9	Diode	1SS53
D11	Diode	1SS53
D12	Diode	1SS53
D13	Diode	1SS53
D14	Diode	1SS53
D15	Diode	1SS53
D16	Diode	1SS53
D17	Diode	1SS53
D18	Diode	1SS53
D19	Diode	1SS53
D20	Diode	1SS53
D21	Diode	1SS53
D22	Diode	1SS53
D23	Diode	1SS53
D24	Diode	1SS53
D25	Diode	1SS53
D26	Diode	1SS53
D27	Diode	1SS53
D28	Diode	1SS53
D29	Diode	1SS53
D30	LED	SLB-22 YY
D32	Diode	1SS53
D34	Diode	1SS53
D35	Diode	1SS53
D36	Diode	1SS53
D37	Diode	1SS53
D38	Diode	1SS53
D39	Diode	1SS53
D40	Diode	1SS53
D41	Diode	1SS53

[FRONT UNIT]

REF. NO.	DESCRIPTION	PART NO.
L1	Choke	BT01RN1-A61
L2	Choke	BT01RN1-A61
L4	Choke	BT01RN1-A61
R1	Resistor	4.7k ELR25
R2	Resistor	100 R20
R3	Resistor	100 R20
R4	Resistor	47k R25
R5	Resistor	3.9k ELR25
R6	Variable	K12B6001A-10KA, 10KC
R7	Resistor	3.3k R25
R8	Trimmer	FR10 20KB
R9	Resistor	10k R25
R13	Variable	K12B6001A-10KB, 10KC
R14	Variable	K12C1000N10KA, 10KB, 500B
R15	Resistor	22k ELR25
R16	Resistor	4.7k R20
R17	Resistor	3.3k R25
R18	Resistor	2.2k ELR25
R19	Resistor	1k R20
R20	Resistor	1k R20
R21	Resistor	47k R25
R22	Resistor	27k ELR25
R23	Resistor	47k ELR25
R24	Resistor	47k R25
R25	Resistor	47k ELR25
R27	Resistor	47k ELR25
R28	Resistor	47k ELR25
R29	Resistor	47k ELR25
R30	Resistor	10k R25
R31	Resistor	47k R25
R32	Resistor	47k ELR25
R33	Resistor	47k ELR25
R34	Resistor	47k ELR25
R35	Resistor	1k R20
R36	Resistor	47k ELR20
R37	Resistor	47k ELR20
R39	Resistor	1.8k ELR10
R40	Resistor	10 R20
R41	Resistor	1k ELR20
R42	Resistor	10k ELR20
R43	Resistor	1k ELR20
R44	Resistor	100 R25
R45	Resistor	4.7k ELR20
R46	Resistor	1k ELR20
R47	Variable	VM10A898-10KB
R48	Resistor	39k R20
R50	Resistor	10k R20
R52	Resistor	47k R25
C1	Ceramic	0.001 50V
C2	Ceramic	0.001 50V
C3	Ceramic	0.001 50V
C4	Ceramic	0.001 50V
C5	Ceramic	0.001 50V
C6	Ceramic	0.001 50V
C7	Ceramic	0.001 50V

[FRONT UNIT]

REF. NO.	DESCRIPTION	PART NO.
C8	Electrolytic	1 50V BP
C10	Ceramic	0.001 50V
C11	Ceramic	0.0047 50V
C12	Electrolytic	10 16V
C13	Electrolytic	33 10V
C14	Electrolytic	470 16V
C15	Electrolytic	100 10V
C16	Electrolytic	1 50V BP
C17	Electrolytic	1 50V BP
C18	Electrolytic	3.3 50V
J1	Connector	B03B-EH-S
J2	Connector	B05B-EH-S
J3	Connector	B12B-EH-S
J4	Connector	S08B-EH-S
J5	Connector	B04B-EH-S
J6	Connector	HLJ4815-01-030
J7	Connector	FM214-8SS (P)
J8	Connector	TLB-P04H-B1
J9	Connector	TLB-P05H-B1
J10	Connector	TLB-P03H-B1
J11	Connector	TLB-P03H-B1
J12	Connector	TLB-P08H-B1
J13	Connector	TLB-P04H-B1
J14	Connector	TLB-P05H-B1
J15	Connector	TLB-P05H-B1
J17	Connector	B02B-EH-S
P1	Connector	EHR-03
P2	Connector	EHR-05
P3	Connector	EHR-04
P4	Connector	EHR-03
P5	Connector	EHR-12
P6	Connector	5250-02
P7	Connector	EHR-03
P8	Connector	EHR-13
P9	Connector	EHR-04
P10	Connector	SMR-04V-B
P12	Connector	TL-25H-02-B1
P13	Connector	5250-02
P14	Connector	EHR-05
P15	Connector	EHR-06
P16	Connector	EHR-07
P17	Connector	EHR-08
P18	Connector	EHR-07
P19	Connector	EHR-12
P20	Connector	EHR-08
P21	Connector	EHR-03
P22	Connector	001T-4100
P23	Connector	EHR-02
P24	Connector	EHR-04
P25	Connector	1625-02P1
P26	Connector	SMF-01T-1.0
DS1	Lamp	BQ044-32582C
ME1	Meter	KL-251L-5
S1	Switch	SUT61D

[FRONT UNIT]

REF. NO.	DESCRIPTION	PART NO.
S2	Switch	M2012J-D3B
S3	Switch	TWA0068-01-233
S4	Switch	HKW0269-01-200
S5	Switch	HKW0269-01-200
S6	Switch	HKW0269-01-200
S7	Switch	HKW0269-01-200
S8	Switch	HKW0269-01-200
S9	Switch	HKW0269-01-200
S10	Switch	HKW0269-01-200
S11	Switch	HKW0269-01-200
S12	Switch	HKW0269-01-200
S13	Switch	HKW0269-01-200
S14	Switch	HKW0269-01-200
S15	Switch	HKW0269-01-200
S16	Switch	HKW0269-01-200
S17	Switch	SUT11A
S18	Switch	SUT11B
S19	Switch	SUT11A
S20	Switch	HKW0145-01-250
S21	Switch	HKW0145-01-250
S22	Switch	HKW0269-01-200
S23	Switch	HKW0269-01-200
S24	Switch	HKW0269-01-200
S25	Switch	HKW0269-01-200
S26	Switch	HKW0269-01-200
S27	Switch	SPH121C
S29	Rotary Encoder	LA24007
EP1	P.C.B	B-646E
EP2	P.C.B	B-649F
EP3	P.C.B	B-1021
EP4	Bead Core	R13.7-5.1-1.4-2D1
W1	Jumper	JPW-02H
W4	Jumper	23/01/110/C21/C21
W5	Jumper	51/00/145/W11A/W11A
W6	Jumper	08 A A
W7	Wire	23/02/125/B06/W03
W8	Wire	23/00/125/B06/W03
W10	Wire	22/04/125/C21/W03
W11	Wire	22/05/150/C21/C32
W12	Wire	23/06/110/C21/W03
W13	Wire	23/00/105/C21/W03
W14	Wire	23/06/220/C21/B06
W15	Wire	23/02/365/C21/B06
W16	Wire	23/02/355/C21/B06
W17	Wire	51/02/370/W11A/B06A
W18	Wire	08 A A
W20	Wire	23/04/370/C21/B06
W21	Wire	23/05/370/C21/B06
W22	Wire	23/03/375/C21/B06
W23	Wire	51/04/410/W15A/A12A
W24	Wire	08 Y A
W25	Wire	23/04/380/C21/B06
W26	Wire	23/05/375/C21/B06
W27	Wire	23/06/375/C21/B06
W28	Wire	23/03/325/C21/B06
W29	Wire	23/01/260/C21/B06
W30	Wire	23/04/245/C21/B06
W31	Wire	23/03/385/C21/B06
W32	Wire	23/01/255/C21/B06
W33	Wire	23/00/410/C21/B06

[FRONT UNIT]

REF. NO.	DESCRIPTION	PART NO.
W34	Wire	23/02/260/C21/B06
W35	Wire	23/03/270/C21/B06
W36	Wire	23/09/270/C21/B06
W37	Wire	23/07/415/C21/B06
W38	Wire	23/02/270/C21/B06
W39	Wire	51/05/385/W11A/B06A
W40	Wire	08 A A
W41	Wire	23/03/280/C21/B06
W42	Wire	23/01/325/C21/B06
W43	Wire	23/01/430/C21/B06
W44	Wire	22/07/275/C21/B06
W45	Wire	23/04/440/C21/B06
W46	Wire	23/04/385/C21/B06
W47	Wire	23/08/295/C21/B06
W49	Wire	22/08/455/C21/B06
W50	Wire	51/00/045/W11A/B06A
W51	Wire	08 A A
W52	Wire	23/01/045/W03/B06
W53	Wire	23/02/045/W03/B06
W54	Wire	23/03/045/W03/B06
W55	Wire	23/04/045/W03/B06
W56	Wire	23/05/045/W03/B06
W57	Wire	23/00/045/W03/B06
W58	Wire	23/01/160/C22/B06
W59	Wire	23/02/160/C22/B06
W60	Wire	23/03/160/C22/B06
W61	Wire	23/04/160/C22/B06
W62	Wire	14/01/210/B01/W02
W63	Wire	14/03/215/B01/W02
W65	Wire	23/03/225/B06/C21
W66	Wire	23/02/195/B06/C21
W67	Wire	23/00/215/B06/C21
W68	Wire	23/06/290/B06/C21
W69	Wire	23/01/305/B06/C21
W70	Wire	23/01/320/B06/C21
W71	Wire	23/02/370/B06/C21
W72	Wire	23/03/205/B06/W05
W73	Wire	23/04/220/B06/W05
W76	Wire	23/01/215/B06/C21
W77	Wire	23/02/215/B06/C21
W78	Wire	23/03/210/B06/C21
W79	Wire	23/04/215/B06/C21
W80	Wire	23/05/215/B06/C21
W81	Wire	23/06/215/B06/C21
W82	Wire	23/07/215/B06/C21
W83	Wire	23/01/315/B06/C22
W84	Wire	23/02/315/B06/C22
W85	Wire	23/03/320/B06/C22
W86	Wire	23/04/320/B06/C22
W87	Wire	23/05/325/B06/C22
W88	Wire	23/06/325/B06/C22
W89	Wire	23/07/320/B06/C22
W90	Wire	23/08/320/B06/C22
W91	Wire	23/01/160/B06/C21
W92	Wire	23/02/180/B06/C21
W93	Wire	23/03/185/B06/C22
W94	Wire	23/04/260/B06/C21
W95	Wire	23/05/175/B06/C22
W96	Wire	23/06/185/B06/C22
W97	Wire	23/01/090/B06/C22
W98	Wire	23/02/095/B06/C22
W99	Wire	23/03/095/B06/C22
W100	Wire	23/04/085/B06/C22
W101	Wire	23/05/095/B06/C22

[FRONT UNIT]

REF. NO.	DESCRIPTION	PART NO.
W102	Wire	23/06/090/B06/C22
W103	Wire	23/07/095/B06/C22
W104	Wire	23/08/095/B06/C22
W105	Wire	23/09/100/B06/C22
W106	Wire	23/00/090/B06/C22
W107	Wire	23/04/095/B06/C22
W108	Wire	23/01/100/B06/C22
W109	Wire	22/02/140/A12/C21
W110	Wire	22/00/135/A12/C21
W111	Wire	23/02/130/B06/C21
W112	Wire	23/01/205/B06/C21
W113	Wire	23/03/140/B06/C21
W114	Wire	23/04/080/B06/C21
W115	Wire	23/05/190/B06/C21
W116	Wire	23/06/130/B06/C21
W117	Wire	23/07/075/B06/C21
W118	Wire	23/08/185/B06/C21
W120	Wire	23/02/135/W03/W03
W121	Jumper	JPW-02A
W122	Jumper	JPW-02A
W123	Jumper	IPS-1041-4
W124	Jumper	JPW-02A
W125	Jumper	JPW-02A
W126	Jumper	JPW-02A
W127	Jumper	JPW-02A
W128	Jumper	IPS-1041-4
W129	Jumper	JPW-02A
W130	Jumper	JPW-02A
W136	Jumper	IPS-1041-2
W139	Jumper	IPS-1041-4
W140	Jumper	IPS-1041-4
W141	Jumper	IPS-1041-4
W143	Jumper	JPW-02A
W147	Jumper	JPW-02A
W150	Jumper	JPW-02A
W151	Jumper	JPW-02A
W152	Jumper	JPW-02A
W159	Wire	23/02/190/B06/C21
W160	Wire	23/00/165/B06/C21
W161	Wire	23/01/135/B06/C21
W162	Wire	23/03/335/C01/C21
W163	Wire	23/05/420/C01/C21
W166	Jumper	JPW-02H
W167	Jumper	IPS-1041-4
W168	Jumper	IPS-1041-4
W169	Jumper	IPS-1041-4
W170	Jumper	IPS-1041-4
W171	Jumper	IPS-1041-4
W172	Jumper	IPS-1041-4
W173	Jumper	23/09/065/C21/C21
W174	Jumper	23/02/140/C21/C21
W175	Jumper	23/03/200/C22/C22
W176	Jumper	23/02/195/C22/C22
W177	Jumper	23/01/190/C22/C22
W178	Jumper	23/06/190/C22/C22
W179	Jumper	23/00/180/C22/C22
W181	Jumper	IPS-1041-4
W182	Jumper	IPS-1041-4
W183	Wire	14/02/215/W02/B01
W185	Jumper	IPS-1041-4
W186	Jumper	IPS-1041-4
W187	Jumper	IPS-1041-4
W188	Jumper	IPS-1041-4
W189	Jumper	IPS-1041-4

[FRONT UNIT]

REF. NO.	DESCRIPTION	PART NO.
W190	Jumper	IPS-1041-4
W191	Jumper	IPS-1041-4
W193	Jumper	IPS-1041-4
W194	Jumper	IPS-1041-4
W195	Jumper	IPS-1041-4
W197	Wire	23/01/280/W04/B06
W198	Wire	23/02/280/W04/B06
W199	Wire	23/03/285/W04/B06
W200	Wire	16/01/150/C21/B30
W201	Jumper	23/03/110/C21/C21
W202	Wire	23/04/260/C21/A03
W203	Wire	23/00/260/C21/A03
W204	Jumper	23/01/070/C21/C21
W206	Jumper	IPS-1041-2
W207	Jumper	IPS-1041-4
W209	Jumper	IPS-1041-2

[DISPLAY UNIT]

REF. NO.	DESCRIPTION	PART NO.
IC1	IC	μPD549 C
IC2	IC	μPD549 C
Q1	Transistor	2SA1015
Q2	Transistor	2SA1015
Q3	Transistor	2SA1015
Q4	Transistor	2SA1015
Q5	Transistor	2SA1015
Q6	Transistor	2SA1015
Q7	Transistor	2SA1015
Q8	Transistor	2SA1015
Q9	Transistor	2SA1015
Q10	Transistor	2SA1015
Q11	Transistor	2SA1015
Q12	Transistor	2SC1214 C
Q13	Transistor	2SC1214 C
Q14	Transistor	2SC1214 C
Q15	Transistor	2SA1015
Q16	Transistor	2SC2785 EF
D1	Diode	1SS55
D3	Diode	1SS55
D4	Diode	1SS55
D5	Diode	1SS55
D8	Zener	RD5.1E B2
D9	Diode	1SS55
D10	Diode	1SS55
D11	Diode	1SS55
D12	Diode	1SS55
D13	Zener	RD5.1E B2
D14	Diode	1SS53
D15	Diode	1SS53
L1	Choke	LW-12
R1	Resistor	1k ELR25
R2	Resistor	1k ELR25
R3	Resistor	1k ELR25
R4	Resistor	1k ELR25
R5	Array	RM-4 47k
R6	Array	RM-4 47k
R7	Array	RM-7 47k
R8	Array	RM-8 47k
R9	Array	RM-5 47k
R10	Array	RM-8 47k
R11	Array	RM-6 47k
R12	Resistor	47k ELR25
R13	Resistor	47k ELR25
R14	Resistor	47k ELR25
R15	Resistor	47k ELR25
R16	Resistor	2.2k ELR25
R17	Resistor	2.2k ELR25
R18	Resistor	100 ELR25
R19	Resistor	47 ELR25
R20	Resistor	10k ELR25
R21	Resistor	2.2k ELR25
R22	Resistor	2.2k ELR25
R23	Resistor	1k ELR25
R24	Resistor	47k ELR25
R25	Resistor	47k ELR25

[DISPLAY UNIT]

REF. NO.	DESCRIPTION	PART NO.	
R26	Resistor	2.2	ELR25
R27	Resistor	47k	ELR25
R28	Resistor	2.2k	ELR25
C1	Ceramic	0.001	50V
C2	Ceramic	0.001	50V
C3	Electrolytic	3.3	50V
C4	Ceramic	330P	50V
C5	Ceramic	330P	50V
C6	Electrolytic	47	16V
C7	Electrolytic	10	16V
C8	Electrolytic	4.7	50V
C9	Electrolytic	4.7	50V
C10	Electrolytic	0.47	50V BP
C11	Electrolytic	10	16V
C12	Ceramic	0.0047	50V
C13	Ceramic	0.0047	50V
C14	Electrolytic	10	16V
J1	Connector	S05B-EH-S	
J2	Connector	SB20P-HVQ-28	
J3	Connector	SB10P-HVQ-28	
J4	Connector	SB13P-HVQ-28	
P1	Connector	EHR-10	
P2	Connector	EHR-11	
DS1	FLD	FIP12AM7	
T1	Transformer	TO-9	
EP1	P.C.B	B-1022A	
EP2	P.C.B	B-742F	
W1	Jumper	RD25UC	
W2	Jumper	RD25UC	
W3	Jumper	RD25UC	
W4	Jumper	RD25UC	
W5	Jumper	RD25UC	
W6	Jumper	RD25UC	
W7	Jumper	JPW-02A	
W8	Jumper	RD25UC	
W9	Jumper	RD25UC	
W10	Jumper	IPS-1041-4	
W11	Jumper	IPS-1041-4	
W12	Jumper	RD25UC	
W13	Jumper	RD25UC	
W14	Jumper	IPS-1041-4	
W15	Jumper	RD25UC	
W16	Jumper	IPS-1041-4	
W17	Jumper	IPS-1041-4	
W18	Jumper	IPS-1041-4	
W19	Jumper	RD25UC	
W20	Jumper	IPS-1041-4	
W21	Jumper	IPS-1041-4	
W22	Jumper	RD25UC	
W23	Jumper	IPS-1041-4	

[DISPLAY UNIT]

REF. NO.	DESCRIPTION	PART NO.
W24	Jumper	IPS-1041-4
W25	Jumper	IPS-1041-4
W26	Jumper	IPS-1041-4
W27	Jumper	IPS-1041-4
W28	Jumper	IPS-1041-4
W29	Jumper	IPS-1041-4
W30	Jumper	IPS-1041-4
W31	Jumper	IPS-1041-4
W32	Jumper	IPS-1041-4
W33	Jumper	RD25UC
W34	Jumper	23/02/070/C21/C21
W35	Jumper	23/06/160/C21/C21
W36	Jumper	23/07/100/C21/C21
W37	Jumper	23/08/125/C21/C21
W38	Jumper	23/04/060/C21/C21
W39	Jumper	23/01/095/C21/C21
W40	Jumper	23/01/100/C21/C21
W41	Jumper	23/05/145/W03/W03
W42	Jumper	23/09/070/C21/C21
W43	Jumper	23/03/050/C21/C21
W44	Jumper	23/02/110/C21/C21
W45	Wire	23/01/255/C21/B06
W46	Wire	23/02/245/C21/B06
W47	Wire	23/03/235/C21/B06
W48	Wire	23/04/270/C21/B06
W49	Wire	23/05/270/C21/B06
W50	Wire	23/06/245/C21/B06
W51	Wire	23/07/275/C21/B06
W52	Wire	23/08/285/C21/B06
W53	Wire	23/09/275/C21/B06
W54	Wire	23/01/275/C21/B06
W55	Wire	23/03/255/C21/B06
W56	Wire	23/01/235/C21/B06
W57	Wire	23/02/225/C21/B06
W58	Wire	23/03/225/C21/B06
W59	Wire	23/04/225/C21/B06
W60	Wire	23/05/220/C21/B06
W61	Wire	23/06/260/C21/B06
W62	Wire	23/07/260/C21/B06
W63	Wire	23/08/255/C21/B06
W64	Wire	23/09/255/C21/B06
W65	Wire	23/00/270/C21/B06
W66	Jumper	23/09/170/C21/C21

[MAIN UNIT]

REF. NO.	DESCRIPTION	PART NO.
IC1	IC	NJM4558D
IC2	IC	BA401
IC3	IC	μPC1037H
IC4	IC	μPC577H
IC5	IC	NJM4558D
IC6	IC	M53323P
IC7	IC	NJM78L05
IC8	IC	μPC577H
IC9	IC	NJM4558D
IC11	IC	NJM4558D
IC12	IC	μPC2002V
IC13	IC	AN829
IC14	IC	MC3357P
IC15	IC	MB3756
Q1	Transistor	2SC945 Q/P/K
Q2	Transistor	2SC945 Q/P/K
Q3	Transistor	2SC945 P
Q4	FET	3SK74 K
Q5	Transistor	2SC945 Q/P/K
Q6	Transistor	2SC945 P
Q7	Transistor	2SC945 P
Q8	Transistor	2SC945 Q/P/K
Q9	Transistor	2SC945 P
Q10	Transistor	2SC945 P
Q11	Transistor	2SA1015
Q12	FET	3SK74 M
Q13	Transistor	2SC945 Q/P/K
Q14	Transistor	2SA1015
Q15	Transistor	2SC945 P/K
Q16	Transistor	2SC945 P/K
Q17	Transistor	2SC945 P
Q18	FET	3SK74 K
Q19	FET	3SK74 M
Q20	Transistor	2SC1645 B
Q21	Transistor	2SC945 P
Q22	Transistor	2SC945 Q/P/K
Q23	Transistor	2SC945 Q/P/K
Q24	Transistor	2SC945 P
Q25	Transistor	2SC945 Q/P/K
Q26	Transistor	2SC945 Q/P/K
Q27	Transistor	2SA1015
Q28	Transistor	2SA1015
Q29	Transistor	2SC945 P/K
Q30	Transistor	2SC945 P
Q31	Transistor	2SC945 Q
Q32	Transistor	2SC945 Q/P/K
Q33	Transistor	2SC945 P
Q34	Transistor	2SC945 Q/P/K
Q35	Transistor	2SC945 Q/P/K
Q36	Transistor	2SA1015
Q37	Transistor	2SC2785 JF/HF/FF/EF/KF
Q38	Transistor	2SA1015
Q39	Transistor	2SC2785 FF/EF/KF
Q40	Transistor	2SA1015
Q41	Transistor	2SC1645 B
Q42	Transistor	2SC2785 JF/HF/FF/EF/KF
Q43	Transistor	2SC3399
Q44	Transistor	2SC3399
Q45	Transistor	2SC2785 JF/HF/FF/EF/KF

[MAIN UNIT]

REF. NO.	DESCRIPTION	PART NO.
Q46	Transistor	2SC3399
Q47	Transistor	2SC3399
Q48	Transistor	2SC3399
D1	Diode	1SS53
D2	Diode	1SS53
D3	Diode	1SS53
D4	Varicap	1S2688 ES
D5	Diode	1SS53
D6	Diode	1SS53
D7	Diode	1SS53
D8	Diode	1SS53
D9	Diode	1SS53
D10	Diode	1SS53
D11	Diode	1SS53
D12	Diode	1SS53
D13	Diode	1SS53
D14	Diode	1SS53
D15	Diode	1SS53
D16	Diode	1SS53
D17	Diode	1SS53
D18	Diode	1SS53
D19	Diode	1SS53
D20	Diode	1SS53
D21	Diode	1SS53
D22	Diode	1SS53
D23	Diode	1SS53
D24	Diode	1SS53
D25	Diode	1SS53
D26	Diode	1SS53
D27	Diode	1SS53
D28	Diode	1SS53
D29	Diode	1K60
D30	Diode	1K60
D31	Diode	1SS53
D32	Diode	1SS53
D33	Diode	1SS53
D35	Diode	1SS53
D36	Diode	1K60
D37	Diode	1K60
D38	Zener	RD3.6E B1
D39	Diode	1SS53
D40	Diode	1SS53
D41	Diode	1SS53
D42	Diode	1SS53
D43	Diode	1SS237
D44	Diode	1SS237
D45	Diode	1SS53
D46	Diode	1SS53
D47	Diode	1SS53
D48	Diode	1SS53
D49	Diode	1SS53
D50	Diode	1SS53
D51	Diode	1SS53
D53	Diode	1SS53
D54	Diode	1SS99
D55	Diode	1SS53
D56	Diode	1SS53
D57	Diode	1SS53
D58	Diode	1SS53
D59	Diode	1SS53
D60	Diode	1S953
D61	Diode	1SS237

[MAIN UNIT]

REF. NO.	DESCRIPTION	PART NO.
D62	Diode	1SS53
D63	Diode	1SS53
D64	Diode	1SS53
D65	Diode	1SS53
D66	Diode	1SS53
D67	Zener	RD6.8E B3
D69	Diode	1SS53
D70	Diode	1SS53
D71	Diode	1SS53
D72	Diode	1SS53
D73	Diode	1SS53
D74	Diode	1SS53
D75	Diode	1SS53
D76	Diode	1SS53
D78	Diode	1SS53
D79	Diode	1SS53
FI1	Crystal	10M24D4
FI2	Ceramic	CFW455E
X1	Crystal	HC18/U 10.75MHz
X2	Crystal	HC18/U 10.7515MHz
X3	Crystal	HC43/U 10.295MHz
L1	Coil	LS-80
L2	Choke	LB4 100
L3	Choke	LB4 100
L4	Choke	LB4 100
L5	Coil	LS-66A
L6	Coil	LS-66A
L7	Coil	LS-149A
L8	Coil	LS-150A
L9	Coil	LS-97
L10	Coil	LS-66A
L11	Coil	LS-66
L12	Coil	LS-66A
L13	Coil	LS-66A
L14	Coil	LS-110A
L15	Coil	LS-151
L16	Coil	LS-121A
L17	Choke	LW-16
L18	Coil	LS-121
L19	Choke	BT01RN1-A61
L20	Choke	BT01RN1-A61
L21	Choke	BT01RN1-A61
R1	Resistor	6.8k ELR25
R2	Resistor	100 ELR25
R3	Resistor	4.7k ELR25
R4	Resistor	1.5k ELR25
R5	Resistor	47 ELR25
R6	Resistor	820 ELR25
R7	Resistor	4.7k ELR25
R8	Resistor	4.7k ELR25
R9	Resistor	3.9k ELR25
R10	Resistor	2.7k ELR25
R11	Resistor	120k ELR25
R12	Resistor	1k ELR25
R13	Resistor	820 ELR25
R14	Resistor	12k ELR25

[MAIN UNIT]

REF. NO.	DESCRIPTION	PART NO.
R15	Resistor	4.7k ELR25
R16	Resistor	22k ELR25
R17	Resistor	560k ELR25
R18	Trimmer	H0651A 1k
R19	Resistor	470 ELR25
R20	Resistor	10k ELR25
R21	Resistor	47k ELR25
R22	Resistor	22k R25
R23	Resistor	5.6k R25
R24	Resistor	5.6k ELR25
R25	Resistor	5.6k ELR25
R26	Resistor	47 ELR25
R27	Resistor	10k ELR25
R28	Resistor	1k ELR25
R29	Trimmer	H0651A 470
R30	Resistor	2.2k R25
R31	Resistor	10k ELR25
R32	Thermistor	23D29
R33	Resistor	47k ELR25
R34	Resistor	33k ELR25
R35	Resistor	470k ELR25
R36	Resistor	4.7k ELR25
R37	Resistor	2.2k ELR25
R38	Resistor	22k ELR25
R39	Resistor	22k ELR25
R40	Resistor	27k ELR25
R41	Resistor	1k ELR25
R42	Resistor	470 ELR25
R43	Resistor	1k R25
R44	Resistor	4.7k ELR25
R45	Resistor	2.2k ELR25
R46	Resistor	33k ELR25
R47	Resistor	100k ELR25
R48	Resistor	100k ELR25
R49	Resistor	100k ELR25
R50	Resistor	1k ELR25
R51	Resistor	68 ELR25
R52	Resistor	100 ELR25
R53	Resistor	2.2k ELR25
R54	Resistor	100 ELR25
R55	Resistor	1k ELR25
R56	Resistor	470 ELR25
R57	Resistor	1k ELR25
R58	Resistor	1k ELR25
R59	Resistor	1k ELR25
R60	Resistor	1k ELR25
R61	Resistor	10k ELR25
R62	Resistor	4.7k ELR25
R63	Trimmer	H0651A 4.7k
R64	Resistor	6.8 ELR25
R65	Resistor	10k ELR25
R66	Resistor	10k ELR25
R67	Resistor	100 ELR25
R68	Resistor	2.2k ELR25
R69	Resistor	1k ELR25
R70	Resistor	10k ELR25
R71	Resistor	10k R25
R72	Trimmer	H0651A 10k
R73	Resistor	47 ELR25
R74	Resistor	2.2k ELR25
R75	Trimmer	H0651A 10k
R76	Resistor	100k ELR25
R77	Resistor	4.7k ELR25
R78	Resistor	2.2k ELR25

[MAIN UNIT]

REF. NO.	DESCRIPTION	PART NO.	
R79	Resistor	10k	ELR25
R80	Resistor	4.7k	ELR25
R81	Resistor	3.3k	ELR25
R82	Trimmer	H0651A	1k
R83	Resistor	100	ELR25
R84	Resistor	100	ELR25
R85	Resistor	4.7k	ELR25
R86	Resistor	330	ELR25
R87	Resistor	1k	ELR25
R88	Resistor	470	ELR25
R89	Resistor	1k	ELR25
R90	Resistor	150	ELR25
R91	Resistor	4.7k	ELR25
R92	Resistor	100	ELR25
R93	Resistor	330	ELR25
R94	Resistor	22k	ELR25
R95	Resistor	1k	ELR25
R96	Resistor	2.2k	ELR25
R97	Resistor	2.2k	ELR25
R98	Resistor	1k	ELR25
R99	Resistor	22	ELR25
R100	Resistor	100	ELR25
R101	Resistor	10k	ELR25
R102	Resistor	100	ELR25
R103	Resistor	220	ELR25
R104	Resistor	100k	ELR25
R105	Resistor	1.2k	ELR25
R106	Resistor	1k	ELR25
R107	Resistor	47k	ELR25
R108	Resistor	100k	ELR25
R109	Resistor	100k	R25
R110	Resistor	47k	ELR25
R111	Resistor	47k	ELR25
R112	Resistor	27k	ELR25
R113	Trimmer	H0651A	47k
R114	Trimmer	H0651A	47k
R115	Resistor	27k	ELR25
R116	Resistor	47k	ELR25
R117	Resistor	100k	ELR25
R118	Resistor	10k	ELR25
R119	Resistor	1M	ELR25
R120	Resistor	150	ELR25
R121	Resistor	3.3M	ELR25
R122	Resistor	10k	ELR25
R123	Resistor	10k	ELR25
R124	Resistor	1k	ELR25
R125	Resistor	330	ELR25
R126	Resistor	100k	ELR25
R127	Resistor	470	ELR25
R128	Resistor	100	ELR25
R129	Resistor	680	ELR25
R130	Resistor	15k	ELR25
R131	Resistor	4.7k	ELR25
R132	Resistor	1k	R25
R133	Resistor	47	ELR25
R134	Resistor	10k	ELR25
R135	Resistor	10k	ELR25
R136	Resistor	220	ELR25
R137	Resistor	2.2k	ELR25
R138	Resistor	47	ELR25
R139	Resistor	330	ELR25
R140	Resistor	10k	ELR25
R141	Resistor	22k	ELR25
R142	Resistor	10k	ELR25

[MAIN UNIT]

REF. NO.	DESCRIPTION	PART NO.	
R143	Resistor	47k	ELR25
R144	Resistor	330	ELR25
R145	Resistor	2.7k	ELR25
R147	Resistor	270	R25
R148	Resistor	10k	ELR25
R149	Trimmer	H0651A	2.2k
R150	Resistor	27k	ELR25
R151	Resistor	47k	ELR25
R152	Trimmer	H0651A	10k
R153	Resistor	100k	ELR25
R154	Resistor	47k	ELR25
R155	Resistor	22k	ELR25
R156	Resistor	2.2k	ELR25
R157	Resistor	10k	ELR25
R158	Resistor	220k	ELR25
R159	Resistor	1k	ELR25
R160	Trimmer	H0651A	1k
R161	Resistor	15k	ELR25
R164	Trimmer	H0651A	47k
R174	Resistor	15k	R25
R175	Resistor	47	ELR25
R176	Resistor	3.9k	ELR25
R177	Resistor	4.7k	ELR25
R178	Resistor	2.2k	ELR25
R179	Resistor	100k	ELR25
R180	Resistor	100	ELR25
R181	Resistor	22k	ELR25
R182	Trimmer	H1051C	10kB
R183	Resistor	1.8k	R25
R184	Resistor	22k	ELR25
R185	Resistor	470k	ELR25
R186	Resistor	10k	ELR25
R187	Resistor	22k	ELR25
R188	Resistor	5.6k	R25
R189	Trimmer	H1051C	100kB
R190	Resistor	22k	ELR25
R191	Resistor	2.2k	ELR25
R192	Resistor	1k	ELR25
R193	Resistor	10k	ELR25
R194	Resistor	22k	ELR25
R195	Resistor	82k	ELR25
R196	Trimmer	H1051C	10kB
R197	Resistor	10k	ELR25
R198	Resistor	220	ELR25
R199	Resistor	4.7	ELR25
R200	Resistor	470	ELR25
R201	Resistor	3.3k	ELR25
R202	Resistor	1k	ELR20
R203	Resistor	39k	ELR20
R204	Resistor	150k	ELR25
R206	Resistor	10k	ELR25
R207	Resistor	120k	ELR25
R208	Resistor	120k	ELR25
R209	Resistor	3.3k	ELR25
R210	Trimmer	H0651A	33k
R211	Resistor	2.2k	ELR25
R212	Thermistor	33D28	
R213	Resistor	2.2k	ELR25
R214	Resistor	33k	ELR25
R215	Resistor	1k	ELR25
R216	Resistor	10k	ELR25
R217	Resistor	100k	ELR25
R218	Resistor	470k	ELR25
R219	Resistor	1.8M	ELR25

[MAIN UNIT]

REF. NO.	DESCRIPTION	PART NO.	
R220	Resistor	1.8M	ELR25
R221	Resistor	1.8M	ELR25
R222	Resistor	390k	ELR25
R223	Resistor	470k	ELR25
R224	Trimmer	H0651A	100k
R225	Resistor	10k	R20
R226	Resistor	10k	ELR25
R227	Resistor	47k	ELR25
R228	Resistor	4.7k	ELR25
R229	Resistor	1k	ELR25
R230	Resistor	2.2k	ELR25
R231	Resistor	47k	ELR25
R232	Resistor	39k	ELR25
R233	Resistor	47k	ELR25
R234	Resistor	4.7k	ELR25
R235	Resistor	4.7k	ELR25
R236	Resistor	10k	ELR25
R237	Resistor	12k	ELR25
R238	Resistor	47k	ELR25
R239	Resistor	47k	ELR25
R240	Trimmer	H0651A	22k
R241	Resistor	1k	ELR25
R242	Resistor	2.2k	ELR25
R243	Resistor	330	ELR25
R244	Trimmer	H1051C	1kB
R245	Resistor	22k	ELR25
R246	Resistor	4.7k	ELR25
R247	Resistor	4.7k	ELR25
R248	Resistor	4.7k	ELR25
R249	Resistor	22k	ELR25
R251	Resistor	22k	ELR25
R252	Resistor	1k	ELR25
R253	Resistor	47k	ELR25
R254	Resistor	10k	ELR25
R255	Resistor	2.2k	ELR25
R256	Resistor	1.8k	ELR25
R257	Trimmer	H1051C	10kB
R258	Resistor	4.7k	ELR25
R259	Resistor	22k	ELR25
R260	Resistor	10k	ELR25
R261	Resistor	2.2k	ELR25
R262	Resistor	1k	ELR25
R263	Resistor	22k	ELR25
R265	Resistor	2.2k	ELR25
R266	Resistor	2.2k	ELR25
R267	Resistor	47	ELR25
R268	Resistor	100	ELR25
R269	Resistor	470	ELR25
R271	Resistor	10k	R25
R276	Resistor	3.3M	ELR25
R277	Resistor	10k	ELR25
R278	Resistor	1.5k	ELR25
R280	Resistor	33k	ELR25
R283	Thermistor	45D26	
R284	Resistor	1M	R20
R285	Resistor	100k	ELR25
R286	Resistor	1k	ELR25
R287	Resistor	100k	R20
C1	Electrolytic	47	10V
C2	Electrolytic	1	50V BP
C3	Electrolytic	10	16V
C4	Barrier Layer	0.1	16V

[MAIN UNIT]

REF. NO.	DESCRIPTION	PART NO.		
C5	Electrolytic	10	16V	RC2
C6	Ceramic	470P	50V	
C7	Ceramic	0.0047	50V	
C8	Ceramic	220P	50V	
C9	Barrier Layer	0.047	25V	
C10	Electrolytic	10	16V	RC2
C11	Electrolytic	0.47	50V	RC2
C12	Mylar	0.01	50V	
C13	Mylar	0.01	50V	
C14	Mylar	0.0022	50V	
C15	Ceramic	100P	50V	
C16	Electrolytic	10	16V	
C17	Barrier Layer	0.1	16V	
C18	Mylar	0.001	50V	
C19	Ceramic	0.0047	50V	
C20	Ceramic	0.0047	50V	
C21	Ceramic	5P	50V	CH
C22	Electrolytic	10	16V	
C23	Ceramic	100P	50V	YL
C24	Ceramic	200P	50V	XL
C25	Ceramic	0.001	50V	
C26	Ceramic	0.0047	50V	
C27	Ceramic	0.0047	50V	
C28	Ceramic	100P	50V	
C29	Ceramic	0.0047	50V	
C30	Ceramic	47P	50V	
C31	Ceramic	0.0047	50V	
C32	Electrolytic	1	50V	RC2
C33	Electrolytic	22	10V	
C34	Barrier Layer	0.047	25V	
C35	Ceramic	0.001	50V	
C36	Barrier Layer	0.047	25V	
C37	Barrier Layer	0.047	25V	
C38	Barrier Layer	0.047	25V	
C39	Ceramic	100P	50V	
C40	Ceramic	220P	50V	
C41	Ceramic	0.0047	50V	
C42	Barrier Layer	0.047	25V	
C43	Barrier Layer	0.047	25V	
C44	Barrier Layer	0.047	25V	
C45	Barrier Layer	0.047	25V	
C46	Barrier Layer	0.047	25V	
C47	Trimmer	CV05E3001	30P	
C48	Ceramic	33P	50V	CH
C49	Dip Mica	150P	50V	
C50	Ceramic	150P	50V	XL
C51	Barrier Layer	0.1	16V	
C52	Barrier Layer	0.047	25V	
C53	Ceramic	47P	50V	
C54	Electrolytic	0.47	50V	
C55	Ceramic	10P	50V	
C56	Barrier Layer	0.047	25V	
C57	Ceramic	100P	50V	
C58	Ceramic	100P	50V	
C59	Ceramic	0.001	50V	
C60	Electrolytic	47	10V	
C61	Mylar	0.033	50V	
C62	Ceramic	0.0047	50V	
C63	Electrolytic	1	50V	
C64	Mylar	0.001	50V	
C65	Barrier Layer	0.1	16V	
C66	Barrier Layer	0.047	25V	
C67	Barrier Layer	0.047	25V	
C68	Ceramic	0.001	50V	

[MAIN UNIT]

REF. NO.	DESCRIPTION	PART NO.	
C69	Electrolytic	10	16V
C70	Ceramic	0.0047	50V
C71	Ceramic	15P	50V
C72	Ceramic	0.001	50V
C73	Ceramic	470P	50V
C74	Ceramic	15P	50V
C75	Barrier Layer	0.047	25V
C76	Barrier Layer	0.047	25V
C77	Ceramic	0.0047	50V
C78	Ceramic	0.0047	50V
C79	Ceramic	47P	50V
C80	Ceramic	0.001	50V
C81	Ceramic	220P	50V
C82	Ceramic	5P	50V
C83	Ceramic	68P	50V
C84	Ceramic	0.001	50V
C85	Barrier Layer	0.1	16V
C86	Barrier Layer	0.047	25V
C87	Barrier Layer	0.047	25V
C88	Ceramic	10P	50V
C89	Barrier Layer	0.047	25V
C90	Electrolytic	22	16V
C91	Barrier Layer	0.047	25V
C92	Ceramic	5P	50V
C93	Barrier Layer	0.1	16V
C94	Ceramic	0.0047	50V
C95	Electrolytic	0.47	50V RC2
C96	Ceramic	0.0047	50V
C97	Electrolytic	0.1	50V RC2
C98	Electrolytic	4.7	25V RC2
C99	Barrier Layer	0.047	25V
C100	Ceramic	470P	50V
C101	Electrolytic	10	16V
C102	Barrier Layer	0.0047	25V
C103	Ceramic	47P	50V
C104	Barrier Layer	0.047	25V
C105	Barrier Layer	0.047	25V
C106	Ceramic	47P	50V
C107	Ceramic	27P	50V
C108	Barrier Layer	0.047	25V
C109	Barrier Layer	0.047	25V
C110	Ceramic	0.001	50V
C111	Ceramic	47P	50V
C112	Barrier Layer	0.047	25V
C113	Barrier Layer	0.047	25V
C114	Barrier Layer	0.047	25V
C115	Ceramic	0.0047	50V
C116	Mylar	0.022	50V
C117	Barrier Layer	0.1	16V
C118	Barrier Layer	0.1	16V
C119	Ceramic	0.0047	50V
C120	Electrolytic	470	16V
C121	Ceramic	0.0047	50V
C122	Ceramic	0.0047	50V
C123	Ceramic	0.0047	50V
C124	Barrier Layer	0.047	25V
C125	Ceramic	10P	50V CH
C126	Barrier Layer	0.1	16V
C127	Barrier Layer	0.047	25V
C128	Barrier Layer	0.047	25V
C129	Ceramic	0.001	50V
C130	Electrolytic	2.2	50V
C131	Barrier Layer	0.1	16V
C132	Ceramic	0.0047	50V

[MAIN UNIT]

REF. NO.	DESCRIPTION	PART NO.	
C133	Electrolytic	10	16V
C134	Ceramic	220P	50V
C135	Ceramic	0.0047	50V
C141	Barrier Layer	0.1	16V
C142	Electrolytic	0.47	50V
C143	Electrolytic	10	16V RC2
C144	Electrolytic	220	10V
C145	Barrier Layer	0.1	16V
C146	Barrier Layer	0.1	16V
C147	Electrolytic	100	10V
C148	Electrolytic	10	16V
C149	Electrolytic	1	50V RC2
C150	Ceramic	0.0047	50V
C151	Electrolytic	0.47	50V RC2
C152	Barrier Layer	0.047	25V
C153	Ceramic	0.0047	50V
C154	Electrolytic	220	10V
C155	Electrolytic	100	10V
C156	Electrolytic	0.47	50V
C157	Electrolytic	220	16V
C158	Ceramic	0.0047	50V
C159	Barrier Layer	0.047	25V
C160	Electrolytic	0.47	50V RC2
C161	Barrier Layer	0.047	25V
C162	Electrolytic	4.7	25V RC2
C163	Electrolytic	10	16V
C164	Barrier Layer	0.047	25V
C165	Barrier Layer	0.047	25V
C166	Ceramic	0.0022	50V
C167	Barrier Layer	0.1	16V
C168	Ceramic	470P	50V
C169	Ceramic	0.001	50V
C170	Ceramic	0.0047	50V
C171	Ceramic	120P	50V SH
C172	Ceramic	10P	50V
C173	Barrier Layer	0.1	16V
C174	Barrier Layer	0.1	16V
C175	Dip Mica	200P	50V
C176	Ceramic	82P	50V CH
C177	Electrolytic	4.7	50V
C179	Electrolytic	2.2	50V
C180	Ceramic	0.001	50V
C181	Ceramic	0.001	50V
C182	Ceramic	470P	50V
C183	Electrolytic	470	16V
C184	Ceramic	0.001	50V
C185	Electrolytic	0.47	50V RC2
C186	Electrolytic	470	16V
C187	Electrolytic	47	10V
C188	Electrolytic	0.47	50V
C189	Electrolytic	2.2	25V MS7
C190	Electrolytic	1	50V
C191	Ceramic	0.0047	50V
C192	Ceramic	0.001	50V
C193	Ceramic	0.0047	50V
C194	Barrier Layer	0.047	25V
C195	Ceramic	0.001	50V
C196	Electrolytic	10	16V RC2
C197	Mylar	0.022	50V
C198	Mylar	0.022	50V
C199	Mylar	0.022	50V
C200	Ceramic	47P	50V
C201	Electrolytic	220	10V
C202	Electrolytic	2.2	50V RC2

[MAIN UNIT]

REF. NO.	DESCRIPTION	PART NO.	
C203	Electrolytic	33	16V
C204	Ceramic	0.0047	50V
C205	Barrier Layer	0.1	16V
C206	Ceramic	0.0047	50V
C208	Ceramic	0.0047	50V
C209	Ceramic	0.001	50V
C210	Mylar	0.0047	50V
C211	Barrier Layer	0.047	25V
C212	Mylar	0.15	50V
C214	Ceramic	0.0047	50V
C215	Ceramic	0.001	50V
C216	Ceramic	0.047	50V
C217	Barrier Layer	0.047	25V
C218	Electrolytic	4.7	25V RC2
C219	Ceramic	0.001	50V
C221	Ceramic	82P	50V
C222	Barrier Layer	0.1	16V
C223	Electrolytic	1	50V RC2
C224	Barrier Layer	0.1	16V
C225	Electrolytic	2.2	50V RC2
C226	Electrolytic	47	10V
C227	Ceramic	0.001	50V
C228	Ceramic	47P	50V
C229	Ceramic	47P	50V
C230	Electrolytic	0.47	50V RC2
C231	Electrolytic	3.3	50V RC2
C232	Barrier Layer	0.1	16V
C233	Barrier Layer	0.1	16V
C235	Ceramic	47P	50V
C236	Ceramic	47P	50V
C237	Barrier Layer	0.047	25V
C238	Ceramic	0.001	50V
C239	Ceramic	0.001	50V
C240	Ceramic	0.001	50V
C241	Ceramic	0.001	50V
C242	Ceramic	0.001	50V
C243	Ceramic	47P	50V
C247	Electrolytic	470	10V
C248	Electrolytic	2.2	50V MS5
C249	Electrolytic	0.47	50V MS5
C250	Electrolytic	10	16V MS5
C251	Electrolytic	0.33	50V MS5
C252	Ceramic	47P	50V
J1	Connector	B04B-EH-S	
J2	Connector	B13B-EH-S	
J3	Connector	B07B-EH-S	
J4	Connector	B04B-EH-S	
J5	Connector	B03B-EH-S	
J6	Connector	B08B-EH-S	
J7	Connector	B12B-EH-S	
J8	Connector	B03B-EH-S	
J9	Connector	B06B-EH-S	
J10	Connector	5045-02A	
J11	Connector	5045-02A	
J12	Connector	5045-02A	
J13	Connector	5045-02A	
J14	Connector	5045-02A	
J15	Connector	B04B-EH-S	
P1	Connector	EHR-04	
P2	Connector	TL-25H-02-B1	

[MAIN UNIT]

REF. NO.	DESCRIPTION	PART NO.	
W1	Jumper	JPW-02H	
W2	Jumper	JPW-02A	
W3	Jumper	JPW-02A	
W4	Jumper	72/98/030/X98/X98	
W5	Jumper	JPW-02A	
W6	Jumper	JPW-02H	
W9	Jumper	JPW-02H	
W11	Jumper	JPW-02H	
W12	Jumper	JPW-02H	
W13	Jumper	JPW-02H	
W14	Jumper	72/98/030/X98/X98	
W15	Jumper	JPW-02H	
W17	Jumper	JPW-02A	
W18	Jumper	JPW-02H	
W19	Jumper	JPW-02H	
W20	Jumper	JPW-02A	
W21	Jumper	JPW-02A	
W22	Jumper	JPW-02A	
W23	Jumper	JPW-02H	
W24	Jumper	JPW-02A	
W25	Jumper	JPW-02H	
W26	Jumper	JPW-02A	
W27	Jumper	23/04/195/C21/C21	
W28	Jumper	23/03/080/C21/C21	
W29	Jumper	23/06/065/C21/C21	
W30	Jumper	23/05/085/C21/C21	
W31	Jumper	23/05/125/C21/C21	
W32	Jumper	51/02/090/W11A/W11A	
W33	Jumper	08	A A
W34	Jumper	61/99/080/W13A/W13A	
W35	Jumper	08	A A
W36	Jumper	61/99/090/W13A/W13A	
W37	Jumper	08	A A
W38	Jumper	23/08/135/C21/C21	
W39	Jumper	23/07/150/C21/C21	
W40	Jumper	23/08/075/C21/C21	
W41	Jumper	23/01/255/C21/C21	
W42	Jumper	61/99/140/W13A/W13A	
W43	Jumper	08	A A
W44	Jumper	23/04/065/C21/W06	
W45	Jumper	JPW-02A	
W46	Jumper	23/07/100/C21/C21	
W47	Jumper	23/05/150/C21/C21	
W48	Jumper	23/09/115/C21/C21	
W49	Jumper	23/02/145/C21/C21	
W50	Jumper	23/01/165/C21/C21	
W51	Jumper	23/09/210/C21/C21	
W52	Jumper	23/08/185/C21/C21	
W53	Jumper	23/08/130/C21/C21	
W54	Jumper	23/06/125/C21/C21	
W55	Jumper	23/03/170/C21/C21	
W56	Jumper	23/05/075/C21/C21	
W57	Jumper	23/07/160/C21/C21	
W58	Jumper	23/09/215/C21/C21	
W59	Jumper	23/09/130/C21/C21	
W60	Jumper	23/04/155/C21/C21	
W62	Jumper	23/04/100/C21/C21	
W63	Jumper	23/03/085/C21/C21	
W64	Jumper	23/07/070/C21/C21	
W65	Jumper	51/04/190/W11A/W11A	
W66	Jumper	08	A A
W67	Jumper	23/02/070/C21/C21	
W68	Jumper	23/02/255/C21/C21	
W69	Jumper	23/06/085/C21/C21	

[MAIN UNIT]

REF. NO.	DESCRIPTION	PART NO.
W70	Jumper	23/01/210/C21/C21
W71	Jumper	23/09/215/C21/C21
W72	Jumper	23/08/215/C21/C21
W73	Jumper	23/07/205/C21/C21
W74	Jumper	23/01/225/C21/C21
W75	Jumper	23/06/170/C21/C21
W76	Jumper	23/06/240/C21/C21
W77	Jumper	23/04/170/C21/C21
W78	Jumper	23/04/245/C21/C21
W79	Jumper	23/05/055/C21/C21
W80	Jumper	23/05/240/C21/C21
W81	Jumper	23/07/265/C21/C21
W82	Jumper	23/09/110/C21/C21
W83	Jumper	23/03/070/C21/C21
W84	Jumper	23/06/180/C21/C21
W85	Jumper	23/08/110/C21/C21
W86	Jumper	23/01/150/C21/C21
W87	Jumper	23/02/205/C21/C21
W88	Jumper	23/03/125/C21/C21
W89	Jumper	23/03/180/C21/C21
W90	Jumper	23/08/180/C21/C21
W91	Jumper	23/01/150/C21/C21
W92	Jumper	23/04/125/W06/W06
W93	Jumper	23/05/230/C21/C21
W94	Jumper	23/05/075/C21/C21
W95	Jumper	23/06/105/C21/C21
W96	Jumper	23/07/170/C21/C21
W97	Jumper	74/98/020/X98/X98
W98	Jumper	JPW-02H
W100	Jumper	23/09/275/C21/C21
W101	Jumper	23/01/080/C21/C21
W102	Jumper	51/04/070/B06A/B06A
W103	Jumper	08 A A
W105	Jumper	51/09/430/W11A/C01A
W106	Jumper	08 A A
W108	Jumper	JPW-02A
W109	Jumper	JPW-02H
W111	Jumper	JPW-02H
W112	Jumper	JPW-02H
W113	Jumper	JPW-02A
W114	Jumper	JPW-02H
W115	Jumper	23/08/100/C21/C21
W116	Jumper	23/03/100/C21/C21
W117	Jumper	23/01/100/C21/C21
W118	Jumper	23/06/080/C21/C21
W119	Jumper	23/01/070/C21/C21
W120	Jumper	23/03/085/C21/C21
W122	Jumper	23/08/110/C21/C21
W123	Jumper	23/01/085/C21/C21
W124	Jumper	JPW-02A
W125	Jumper	72/98/030/X98/X98
W126	Jumper	JPW-02H
W128	Jumper	JPW-02A
W129	Jumper	JPW-02A
W130	Jumper	JPW-02H
W131	Jumper	JPW-02H

[PLL UNIT]

REF. NO.	DESCRIPTION	PART NO.
IC1	IC	M54929P
IC2	IC	M54466L
IC3	IC	NJM4558D
IC4	IC	MN1201A
IC5	IC	TC4017BP
IC6	IC	ND487C1-3R
IC7	IC	TA78L008AP
IC8	IC	TA78L008AP
Q1	Transistor	2SC1815 Y
Q2	FET	2SK241 GR
Q3	Transistor	2SC1923 Y
Q4	Transistor	2SC2570 A
Q5	Transistor	2SC2026
Q6	Transistor	2SC2367
Q8	FET	2SK30A GR
Q9	Transistor	2SC1740 LNR
Q10	FET	2SK192A GR
Q11	FET	2SK192A GR
Q12	Transistor	2SC763 C
Q13	Transistor	2SC763 C
Q14	Transistor	2SC763 C
Q15	Transistor	2SC1815 Y
Q16	Transistor	2SC763 C
Q17	Transistor	2SC383TM
Q18	Transistor	2SC763 C
Q19	FET	3SK74 M
Q20	Transistor	2SC763 C
Q21	Transistor	2SC383TM
Q22	Transistor	2SC1815 Y
Q23	Transistor	2SA1015 Y
Q24	Transistor	2SC383TM
D1	Zener	RD6.8E B3
D2	Diode	1S953
D3	Diode	1S953
D4	Varicap	1SV50E(1)
D5	Diode	1SS53
D6	Diode	1SS53
D7	Diode	1SS53
D8	Varicap	1SV50E(1)
D9	Diode	1SS53
D10	Diode	1SS53
D11	Diode	1SS53
D12	Diode	1SS53
D13	Zener	RD6.8E B3
D14	Varicap	1SV50E(1)
D15	Zener	RD6.8E B3
D16	Varicap	1SV50E(1)
D17	Zener	RD7.5E B2
F11	Helical	252MX-1815F
F12	Helical	252MX-1815F
F14	Helical	252MN-1427A
F15	Helical	252MN-1427A
X1	Crystal	CR123
X2	Crystal	CR124
X3	Crystal	HC43/U 5.12MHz

[PLL UNIT]

REF. NO.	DESCRIPTION	PART NO.
L1	Coil	LS-130
L2	Coil	LS-259
L3	Coil	LS-259
L4	Coil	LS-259
L5	Coil	LS-230A
L6	Coil	JPW-02H
L7	Coil	JPW-02H
L9	Coil	LR-145
L10	Coil	LR-145
L11	Coil	LAL03NA 1R0
L12	Coil	LAL03NA 1R0
L17	Coil	LR-79
L18	Coil	FL4H 100
L19	Coil	LB-135
L20	Coil	LAL03NA 1R0
L21	Coil	LR-79
L22	Coil	FL4H 100
L23	Coil	LB-135
L24	Coil	FL5H 101
L25	Coil	FL5H 101
L27	Coil	LS-231
L28	Coil	LS-231
L29	Coil	LS-177
L30	Coil	LS-177
L31	Coil	LAL02KR 100
L32	Coil	LS-94
L33	Coil	LAL02KR R33
L34	Coil	LS-112
L35	Coil	LS-112
L36	Coil	LS-112
L37	Coil	LS-112
L38	Coil	LA-233
L39	Coil	LA-235
L40	Coil	FL5H 101
L41	Coil	LA-236
L42	Coil	LA-255
L43	Coil	LA-254
L44	Coil	LA-232
L45	Coil	LAL03NA 1R0
L46	Coil	LAL03NA 1R0
L47	Coil	LAL03NA 1R0
L48	Coil	LAL03NA 1R0
L49	Coil	LAL03NA 1R0
L50	Coil	LAL03NA 1R0
L51	Coil	LAL02KR 1R0
L52	Coil	LAL02KR 1R0
R1	Resistor	10k ELR25
R2	Resistor	1k ELR25
R3	Resistor	4.7k ELR25
R4	Resistor	330 ELR20
R5	Resistor	220 ELR25
R6	Resistor	47k R20
R7	Resistor	220 ELR25
R8	Resistor	100 ELR20
R9	Resistor	100 ELR20
R10	Resistor	100 ELR20
R11	Resistor	10k ELR20
R12	Resistor	1k ELR20
R13	Resistor	100 R25
R14	Resistor	3.3k ELR20
R15	Resistor	470 ELR20
R19	Resistor	100 R25

[PLL UNIT]

REF. NO.	DESCRIPTION	PART NO.
R20	Resistor	6.8k ELR20
R21	Resistor	1k ELR20
R22	Resistor	100 R25
R23	Resistor	4.7k ELR20
R24	Resistor	1k ELR20
R28	Resistor	100 R25
R29	Resistor	10k ELR20
R30	Resistor	100 ELR20
R31	Resistor	1.5k R25
R32	Resistor	10k ELR25
R33	Resistor	1.5k ELR20
R34	Resistor	330 ELR25
R35	Resistor	2.2k ELR20
R36	Resistor	1.5k ELR25
R37	Resistor	4.7k R25
R38	Resistor	1k ELR20
R39	Resistor	47 ELR20
R40	Resistor	100k ELR20
R41	Resistor	100k ELR20
R42	Resistor	100 ELR20
R43	Resistor	2.2k ELR20
R44	Resistor	100 R25
R45	Resistor	1k ELR20
R46	Resistor	47 ELR20
R47	Resistor	100k ELR20
R48	Resistor	100 ELR20
R49	Resistor	100k ELR20
R50	Resistor	2.2k ELR20
R51	Resistor	100 R25
R52	Resistor	5.6k ELR20
R53	Resistor	4.7k ELR20
R54	Resistor	100 R25
R55	Resistor	330 ELR20
R56	Resistor	22 R25
R57	Resistor	470 ELR20
R58	Resistor	10k ELR20
R59	Resistor	22k ELR20
R60	Resistor	560 ELR20
R61	Resistor	220 ELR20
R62	Resistor	10k ELR20
R63	Resistor	10k ELR20
R64	Resistor	100 ELR20
R65	Resistor	220 ELR20
R69	Resistor	47k ELR20
R70	Resistor	22k ELR20
R71	Resistor	10k ELR20
R72	Resistor	390 ELR25
R73	Resistor	2.7k ELR25
R74	Resistor	56 ELR25
R75	Resistor	100 R25
R76	Resistor	1k ELR25
R77	Resistor	22k ELR25
R78	Resistor	4.7k ELR25
R79	Resistor	220 ELR25
R80	Resistor	1k ELR25
R81	Resistor	33k ELR20
R82	Resistor	10k ELR25
R83	Resistor	100k ELR20
R84	Resistor	10k ELR20
R85	Trimmer	H0651A 10k
R86	Resistor	1.8M ELR20
R87	Resistor	100 ELR25
R88	Resistor	270k ELR25
R89	Resistor	100 ELR20

[PLL UNIT]

REF. NO.	DESCRIPTION	PART NO.	
R90	Resistor	10k	ELR25
R91	Resistor	3.3M	ELR25
R92	Trimmer	H0651A	1k
R93	Resistor	22k	ELR20
R94	Trimmer	H0651A	47k
R95	Resistor	480k	CRB25DX
R96	Resistor	100k	CRB25DX
R97	Resistor	200k	CRB25DX
R98	Resistor	400k	CRB25DX
R99	Resistor	800k	CRB25FX
R100	Resistor	100k	CRB25DX
R101	Resistor	200k	CRB25DX
R102	Resistor	400k	CRB25DX
R103	Resistor	800k	CRB25FX
R104	Resistor	22k	ELR20
R105	Resistor	4.7k	ELR20
R106	Resistor	270	ELR20
R107	Resistor	100	R25
R108	Resistor	47	R25
R109	Resistor	220	ELR20
R110	Resistor	1k	ELR25
R111	Resistor	22k	ELR25
R112	Resistor	5.6k	ELR20
R113	Resistor	220	ELR25
R114	Resistor	100	ELR25
R115	Resistor	330	ELR20
R116	Resistor	10k	ELR20
R117	Resistor	15k	ELR25
R118	Resistor	10k	ELR20
R119	Resistor	10k	ELR20
R120	Resistor	100k	ELR25
R121	Resistor	5.6k	ELR25
R122	Trimmer	H0651A	4.7k
R123	Resistor	10k	ELR20
R124	Resistor	470	ELR20
R125	Resistor	10k	ELR25
R126	Resistor	220	R25
R127	Resistor	220	ELR20
R130	Resistor	100k	ELR25
R131	Resistor	15k	ELR20
R132	Resistor	1k	R20
R133	Resistor	150	ELR20
R134	Resistor	8.2	ELR20
R135	Resistor	8.2	ELR20
R136	Resistor	1k	R20
R137	Resistor	8.2	ELR20
R138	Resistor	8.2	ELR20
R139	Resistor	150	ELR20
R140	Resistor	270	R20
R141	Resistor	100	R20
R142	Resistor	100	R20
R144	Resistor	100	ELR20
R146	Resistor	100	ELR20
R147	Resistor	47k	ELR20
R148	Resistor	330	R25
R149	Thermistor	23D29	
R150	Resistor	220k	ELR20
R151	Resistor	56	R20
R152	Resistor	270	R20
R153	Resistor	15	R20
C1	Dip Mica	15P	50V
C3	Ceramic	0.001	50V

[PLL UNIT]

REF. NO.	DESCRIPTION	PART NO.	
C4	Electrolytic	47	10V
C5	Ceramic	39P	50V CH
C6	Ceramic	47P	50V CH
C7	Ceramic	5P	50V
C8	Cylinder	UP125SL	1P
C9	Ceramic	8P	50V
C10	Cylinder	UP125SL	1P
C11	Ceramic	6P	50V
C12	Ceramic	1P	50V
C13	Ceramic	0.0047	50V
C14	Ceramic	15P	50V
C16	Ceramic	0.001	50V
C17	Ceramic	100P	50V
C18	Ceramic	8P	50V
C19	Ceramic	0.001	50V
C20	Ceramic	0.001	50V
C21	Trimmer	CV38A0601	6PF
C22	Ceramic	2P	50V
C23	Ceramic	100P	50V
C24	Ceramic	3P	50V
C25	Feed Through	TF240-602SS332X	50V
C26	Ceramic	0.001	50V
C27	Ceramic	0.001	50V
C29	Trimmer	CV38A0601	6PF
C30	Ceramic	2P	50V
C32	Barrier Layer	0.1	16V
C33	Barrier Layer	0.1	16V
C34	Ceramic	0.0047	50V
C35	Electrolytic	100	16V
C39	Ceramic	47P	50V
C42	Ceramic	8P	50V
C43	Feed Through	TF240-602SS332Z	50V
C44	Ceramic	0.001	50V
C45	Ceramic	0.001	50V
C46	Ceramic	5P	50V
C47	Ceramic	22P	50V
C48	Feed Through	TF240-602SS332Z	50V
C49	Ceramic	0.001	50V
C50	Ceramic	0.001	50V
C51	Ceramic	6P	50V
C52	Ceramic	47P	50V
C53	Ceramic	0.001	50V
C62	Ceramic	0.001	50V
C63	Ceramic	0.001	50V
C64	Ceramic	0.001	50V
C65	Ceramic	0.001	50V
C66	Ceramic	0.001	50V
C67	Ceramic	0.001	50V
C68	Ceramic	0.001	50V
C69	Electrolytic	1	50V BP
C70	Barrier Layer	0.047	25V
C71	Ceramic	0.001	50V
C72	Electrolytic	100	10V
C73	Ceramic	0.001	50V
C74	Electrolytic	22	16V
C75	Ceramic	56P	50V PH
C76	Ceramic	15P	50V CH
C77	Trimmer	CTZ51A	6P
C78	Ceramic	15P	50V CH
C79	Ceramic	33P	50V CH
C80	Ceramic	0.001	50V

[PLL UNIT]

REF. NO.	DESCRIPTION	PART NO.	
C81	Ceramic	0.0047	50V
C82	Ceramic	10P	50V CH
C83	Ceramic	10P	50V CH
C84	Electrolytic	47	10V
C85	Barrier Layer	0.1	16V
C86	Electrolytic	22	16V
C87	Ceramic	39P	50V PH
C88	Ceramic	3P	50V CH
C89	Ceramic	0.001	50V
C90	Ceramic	6P	50V CH
C91	Trimmer	CTZ51A	6P
C92	Ceramic	30P	50V CH
C93	Ceramic	0.001	50V
C94	Ceramic	0.0047	50V
C95	Ceramic	10P	50V CH
C96	Ceramic	5P	50V CH
C97	Ceramic	0.5P	50V CK
C98	Electrolytic	47	10V
C99	Ceramic	0.0047	50V
C100	Ceramic	0.001	50V
C101	Electrolytic	47	10V
C102	Ceramic	33P	50V
C103	Ceramic	68P	50V
C104	Ceramic	0.001	50V
C105	Ceramic	0.001	50V
C106	Ceramic	0.001	50V
C107	Ceramic	0.001	50V
C108	Ceramic	0.0047	50V
C109	Ceramic	62P	50V
C110	Ceramic	0.001	50V
C111	Electrolytic	47	10V
C112	Ceramic	0.0047	50V
C113	Array	B7ZC0717-32N	
			470PX6
C114	Electrolytic	0.47	50V
C115	Barrier Layer	0.01	25V
C116	Ceramic	0.001	50V
C118	Ceramic	0.0047	50V
C119	Ceramic	0.0047	50V
C121	Ceramic	0.0047	50V
C122	Ceramic	20P	50V
C123	Ceramic	1.5P	50V
C124	Ceramic	15P	50V
C125	Ceramic	0.001	50V
C126	Ceramic	0.001	50V
C127	Ceramic	0.001	50V
C128	Ceramic	0.001	50V
C129	Ceramic	8P	50V
C130	Ceramic	1.5P	50V
C131	Ceramic	8P	50V
C132	Ceramic	0.001	50V
C133	Ceramic	0.001	50V
C134	Ceramic	100P	50V CH
C135	Ceramic	100P	50V CH
C136	Ceramic	0.001	50V
C137	Electrolytic	10	16V
C138	Ceramic	47P	50V
C139	Ceramic	0.001	50V
C140	Ceramic	0.001	50V
C141	Ceramic	0.001	50V
C142	Ceramic	0.0022	50V
C143	Ceramic	0.001	50V
C144	Ceramic	0.001	50V
C145	Ceramic	0.001	50V

[PLL UNIT]

REF. NO.	DESCRIPTION	PART NO.	
C146	Ceramic	0.001	50V
C147	Ceramic	5P	50V
C148	Ceramic	0.001	50V
C149	Ceramic	22P	50V
C150	Ceramic	0.001	50V
C151	Ceramic	22P	50V
C152	Ceramic	0.001	50V
C153	Ceramic	0.001	50V
C154	Ceramic	3P	50V
C155	Ceramic	0.0047	50V
C156	Ceramic	0.35P	50V
C157	Ceramic	5P	50V
C158	Ceramic	10P	50V
C159	Ceramic	0.0047	50V
C160	Ceramic	3P	50V
C161	Ceramic	0.001	50V
C162	Ceramic	0.35P	50V
C163	Ceramic	5P	50V
C164	Ceramic	0.0047	50V
C165	Ceramic	9P	50V
C166	Ceramic	51P	50V
C167	Ceramic	30P	50V
C168	Ceramic	10P	50V
C169	Ceramic	22P	50V
C170	Ceramic	220P	50V CH
C171	Ceramic	220P	50V CH
C172	Ceramic	220P	50V CH
C173	Ceramic	180P	50V CH
C174	Ceramic	0.001	50V
C175	Electrolytic	10	16V
C176	Ceramic	0.001	50V
C177	Ceramic	5P	50V
C178	Ceramic	0.001	50V
C179	Ceramic	0.001	50V
C180	Ceramic	0.001	50V
C181	Ceramic	0.001	50V
C182	Electrolytic	10	16V
C183	Ceramic	0.001	50V
C184	Ceramic	0.001	50V
C185	Ceramic	0.001	50V
C186	Electrolytic	47	16V
C187	Ceramic	24P	50V
C188	Ceramic	15P	50V
C189	Ceramic	51P	50V
C190	Ceramic	8P	50V
C191	Ceramic	62P	50V
C192	Ceramic	3P	50V
C193	Ceramic	36P	50V
C194	Ceramic	47P	50V
C196	Ceramic	0.001	50V
C200	Ceramic	47P	50V
C201	Barrier Layer	0.1	16V
C202	Ceramic	3P	50V
C203	Ceramic	47P	50V
C204	Ceramic	10P	50V
C205	Ceramic	47P	50V
C206	Ceramic	3P	50V
C207	Ceramic	3P	50V
C208	Ceramic	3P	50V
C209	Ceramic	47P	50V
C210	Ceramic	0.001	50V
C211	Ceramic	3P	50V
C212	Ceramic	3P	50V
C213	Ceramic	3P	50V

[PLL UNIT]

REF. NO.	DESCRIPTION	PART NO.
C214	Ceramic	47P 50V
C215	Ceramic	3P 50V
C216	Ceramic	3P 50V
C217	Ceramic	3P 50V
C218	Ceramic	3P 50V
C219	Ceramic	0.001 50V
C220	Ceramic	3P 50V
C221	Ceramic	3P 50V
C222	Ceramic	3P 50V
C223	Ceramic	3P 50V
C224	Ceramic	0.0047 50V
J1	Connector	B05B-EH-S
J2	Connector	B04B-EH-S
J3	Connector	TLB-P08H-B1
J4	Connector	TLB-P04H-B1
P1	Connector	TMP-P01X-A1
P2	Connector	TMP-P01X-A1
P3	Connector	EHR-12
P4	Connector	5250-02
P5	Connector	5250-02
EP1	P.C.B	B-968B
W1	Wire	23/01/300/C22/B06
W2	Wire	23/02/300/C22/B06
W3	Wire	23/03/300/C22/B06
W4	Wire	23/04/300/C22/B06
W5	Wire	23/05/300/C22/B06
W6	Wire	23/06/300/C22/B06
W7	Wire	23/07/300/C22/B06
W8	Wire	23/08/300/C22/B06
W9	Wire	23/09/300/C22/B06
W10	Wire	23/00/300/C22/B06
W11	Wire	23/01/300/C22/B06
W12	Wire	23/02/300/C22/B06
W13	Jumper	23/08/080/C21/C21
W14	Jumper	23/08/085/C21/C21
W15	Jumper	23/08/065/C21/C21
W16	Jumper	23/08/215/C21/C21
W17	Jumper	23/08/080/C21/C21
W18	Jumper	23/08/085/C21/C21
W19	Jumper	23/05/250/C21/C21
W20	Jumper	23/05/070/C21/C21
W21	Jumper	23/04/140/C21/C21
W22	Jumper	23/03/130/C21/C21
W23	Jumper	23/02/075/C21/C21
W24	Jumper	23/01/050/C21/C21
W25	Jumper	23/01/200/C21/C21
W26	Jumper	23/02/200/C21/C21
W27	Jumper	61/99/105/W13A/W13A
W28	Jumper	08 A A
W29	Jumper	61/99/080/W13A/W13A
W30	Jumper	08 A A
W31	Jumper	22/03/210/C21/C21
W32	Jumper	23/07/060/C21/C21
W33	Wire	22/03/135/A12/W02
W34	Wire	22/00/135/A12/W02
W35	Wire	22/05/100/A12/W02

[PLL UNIT]

REF. NO.	DESCRIPTION	PART NO.
W36	Wire	22/00/100/A12/W02
W37	Wire	62/99/110/W99/C31
W38	Wire	08 Y
W39	Wire	62/99/220/W99/C31
W40	Wire	08 Y
W41	Jumper	72/98/030/X98/X98
W42	Jumper	JPW-02A
W45	Jumper	JPW-02A
W46	Jumper	IPS-1041-2
W48	Jumper	IPS-1041-2
W49	Jumper	IPS-1041-2
W50	Jumper	JPW-02A
W51	Jumper	JPW-02A
W52	Jumper	IPS-1041-2
W53	Jumper	IPS-1041-2
W56	Jumper	JPW-02A
W57	Jumper	JPW-02A
W59	Jumper	JPW-02A
W61	Jumper	IPS-1041-2
W62	Jumper	IPS-1041-2

[LOGIC UNIT]

REF. NO.	DESCRIPTION	PART NO.
IC1	IC	4081
IC2	IC	4081
IC3	IC	4001
IC4	IC	74LS74
IC5	IC	74LS11
IC6	IC	74LS08
IC7	IC	RP5G01-007
IC8	IC	μPD7801G 114
IC9	IC	M50781SP
IC10	IC	BA618
IC11	IC	74LS02
IC12	IC	74LS377
IC13	IC	4011
IC14	IC	7432
IC15	IC	7408
IC16	IC	4013
IC18	IC	7404
IC19	IC	S-7116A (#03 only)
IC20	IC	74LS123
IC22	IC	TA78L009AP
Q1	Transistor	2SC945 P (#03, 04)
Q2	Transistor	2SA1015
Q3	Transistor	2SA1015
Q4	Transistor	2SA1015
Q7	Transistor	2SC945 P (#03 only)
D1	Diode	1SS53
D2	Diode	1SS53
D3	Diode	1SS53
D4	Diode	1SS53
D5	Diode	1SS53
D7	Diode	1SS53
D8	Diode	1SS53
D9	Diode	1SS53
D12	Diode	1SS53
D13	Diode	1SS53
D14	Diode	1SS53
D15	Diode	1SS53
D16	Diode	1SS53
D18	Diode	1SS53
D21	Diode	1SS53
D25	Diode	1SS53
D27	Diode	1SS53
D28	Diode	1SS53
D29	Diode	1SS53
D34	Diode	1SS53
D35	Diode	1SS53
X1	Crystal	HC43/U 3.5795MHz (#03 only)
X2	Cera Lock	CSA4.00MT
R1	Resistor	47k ELR25
R3	Resistor	100 ELR25 (#03, 04)

[LOGIC UNIT]

REF. NO.	DESCRIPTION	PART NO.
R4	Resistor	560k ELR25 (#03, 04)
R5	Resistor	47k ELR25 (#03, 04)
R7	Resistor	47k ELR25
R8	Resistor	150k ELR25
R9	Resistor	68k ELR25
R10	Resistor	470 ELR25
R11	Resistor	10k ELR25
R12	Resistor	4.7k R25
R13	Resistor	4.7k ELR25
R14	Resistor	4.7k ELR25
R15	Resistor	47k R25
R16	Resistor	390 ELR25
R17	Resistor	4.7k R25
R18	Resistor	150k ELR25
R19	Resistor	3.3M ELR25
R20	Resistor	1M ELR25
R21	Trimmer	H0651A 470k
R22	Resistor	3.3M ELR25
R23	Resistor	2.7k ELR25
R24	Resistor	56k ELR25
R25	Resistor	1M R20
R26	Resistor	1M ELR25
R27	Resistor	47k ELR25
R28	Resistor	47k ELR25
R29	Resistor	470 ELR25
R30	Resistor	10k ELR25
R31	Resistor	10k ELR25
R32	Resistor	47k ELR25
R34	Resistor	680 ELR25
R35	Resistor	220 ELR25
R36	Resistor	680 ELR25
R37	Resistor	220 ELR25
R38	Array	RM-8 4.7k
R39	Resistor	47k R25
R40	Array	RM-4 100k
R41	Resistor	470 ELR25 (#03, 04)
R42	Resistor	2.2k ELR25
R43	Resistor	47k ELR25
R44	Resistor	47k ELR25
R45	Resistor	100 ELR25 (#03, 04)
R46	Resistor	3.3k ELR25 (#03, 04)
R47	Resistor	27k ELR25
R51	Resistor	10M ERC-14GJ
R52	Resistor	47k ELR20 (#03 only)
R54	Resistor	47k ELR25
R55	Resistor	100 R20 (#03 only)
R56	Resistor	5.6k R20 (#03 only)
R57	Resistor	H0651A 2.2k (#03 only)
R59	Resistor	47k R20
R60	Resistor	47k R20
C1	Electrolytic	47 16V
C3	Electrolytic	47 16V (#03, 04)

[LOGIC UNIT]

REF. NO.	DESCRIPTION	PART NO.
C4	Ceramic	0.01 50V FZ (#03, 04)
C6	Ceramic	22P 50V (#03 only)
C7	Ceramic	22P 50V (#03 only)
C8	Ceramic	100P 50V
C9	Ceramic	220P 50V
C10	Ceramic	0.001 50V
C11	Barrier Layer	0.1 16V
C12	Electrolytic	47 16V
C15	Ceramic	30P 50V
C16	Ceramic	30P 50V
C17	Barrier Layer	0.1 16V
C18	Ceramic	0.001 50V
C19	Electrolytic	4.7 25V
C20	Barrier Layer	0.1 16V
C21	Electrolytic	47 16V
C22	Barrier Layer	0.015 25V
C23	Barrier Layer	0.1 16V
C24	Barrier Layer	0.1 16V
C27	Electrolytic	47 10V
C29	Ceramic	0.001 50V
C30	Mylar	0.022 50V (#03 only)
C31	Electrolytic	47 10V (#03 only)
C32	Barrier Layer	0.1 16V
J1	Connector	TL-25P-09-V1
J2	Connector	B6B-EH-S
J3	Connector	TL-25P-08-V1
J4	Connector	B07B-EH-S
J5	Connector	B07B-EH-S
J6	Connector	B08B-EH-S
J7	Connector	B10B-EH-S
J8	Connector	5045-02A
J9	Connector	B10B-EH-S
J10	Connector	TL-25P-08-V1
J11	Connector	B12B-EH-S
J12	Connector	B03B-EH-S
J13	Connector	5045-02A
J14	Connector	B04B-EH-S
J15	Connector	B11B-EH-S
J16	Connector	3022-12B
J17	Connector	3022-08B
J19	Connector	5045-02A
P1	Connector	5250-02 (#03 only)
P2	Connector	SMR-03V-B
P3	Connector	SMF-01T-1.0
EP1	P.C.B	B-802B
EP4	RAM Unit	EX-314-15 (#02 only)
EP4	RAM Unit	EX-314-16 (#03 only)
EP4	RAM Unit	EX-314-17 (#04 only)

[LOGIC UNIT]

REF. NO.	DESCRIPTION	PART NO.
W2	Jumper	RD25UC
W3	Jumper	IPS-1041-4
W4	Jumper	IPS-1041-4
W6	Jumper	RD25UC
W7	Jumper	IPS-1041-4
W8	Jumper	IPS-1041-4
W9	Jumper	RD25Z
W10	Jumper	IPS-1041-4
W11	Jumper	IPS-1041-4
W12	Jumper	RD25Z
W13	Jumper	IPS-1041-4
W14	Jumper	IPS-1041-4
W15	Jumper	IPS-1041-4
W16	Jumper	IPS-1041-4
W17	Jumper	IPS-1041-4
W18	Jumper	IPS-1041-4
W19	Jumper	IPS-1041-4
W20	Jumper	IPS-1041-4
W21	Jumper	IPS-1041-4
W22	Jumper	IPS-1041-4
W23	Jumper	IPS-1041-4
W24	Jumper	JPW-02H
W25	Jumper	IPS-1041-4
W26	Jumper	IPS-1041-4
W27	Jumper	IPS-1041-4
W29	Jumper	IPS-1041-4
W30	Jumper	IPS-1041-4
W32	Jumper	IPS-1041-4
W33	Jumper	RD25UC
W34	Jumper	IPS-1041-4
W35	Jumper	RD25UC
W37	Jumper	IPS-1041-4
W38	Jumper	JPW-02A
W39	Jumper	IPS-1041-4
W40	Jumper	JPW-02A
W41	Jumper	IPS-1041-4
W42	Jumper	IPS-1041-4
W43	Jumper	RD25Z
W44	Jumper	RD25Z
W46	Jumper	IPS-1041-4
W47	Jumper	IPS-1041-4
W50	Jumper	IPS-1041-4
W52	Jumper	IPS-1041-4
W54	Jumper	IPS-1041-4
W55	Jumper	IPS-1041-4
W56	Jumper	IPS-1041-4
W57	Jumper	RD25UC
W58	Jumper	IPS-1041-4
W59	Jumper	IPS-1041-4
W60	Jumper	IPS-1041-4
W61	Jumper	IPS-1041-4
W62	Jumper	IPS-1041-4
W63	Jumper	23/01/055/C21/C21
W65	Jumper	IPS-1041-4
W66	Jumper	IPS-1041-4
W67	Jumper	IPS-1041-4
W68	Jumper	IPS-1041-4
W69	Jumper	JPW-02A
W70	Jumper	RD25Z
W71	Jumper	IPS-1041-4
W72	Jumper	IPS-1041-4
W73	Jumper	RD25UC
W74	Jumper	RD25Z
W75	Jumper	RD25Z

[LOGIC UNIT]

REF. NO.	DESCRIPTION	PART NO.
W76	Jumper	IPS-1041-4
W77	Jumper	IPS-1041-4
W78	Jumper	IPS-1041-4
W79	Jumper	IPS-1041-4
W81	Jumper	RD25Z
W82	Jumper	IPS-1041-4
W83	Jumper	RD25UC
W84	Jumper	IPS-1041-4
W85	Jumper	IPS-1041-4
W86	Jumper	IPS-1041-4
W87	Jumper	RD25Z
W88	Jumper	JPW-02A
W89	Jumper	RD25UC
W90	Jumper	IPS-1041-4
W91	Jumper	RD25UC
W92	Jumper	RD25UC
W93	Jumper	RD25UC
W94	Jumper	IPS-1041-4
W95	Jumper	IPS-1041-4
W96	Jumper	IPS-1041-4
W97	Jumper	IPS-1041-4
W98	Jumper	RD25UC
W99	Jumper	IPS-1041-4
W100	Jumper	23/02/120/C21/C21
W101	Jumper	23/04/215/C21/C21 (#03 only)
W102	Jumper	23/05/175/C21/C21
W103	Jumper	23/03/205/C21/C21 (#03, 04)
W104	Jumper	23/02/145/C21/C21
W105	Jumper	23/00/095/C21/C21
W106	Jumper	23/05/215/C21/C21
W107	Jumper	23/06/125/C21/C21
W108	Jumper	23/07/120/C21/C21
W109	Jumper	23/09/255/C21/C21
W110	Jumper	23/08/090/C21/C21
W111	Jumper	23/00/130/C21/C21
W113	Jumper	23/01/105/C21/C21
W114	Jumper	23/00/100/C21/C21
W115	Jumper	23/09/100/C21/C21
W116	Jumper	23/03/095/C21/C21
W117	Jumper	23/04/140/C21/C21
W118	Jumper	23/08/140/C21/C21
W119	Jumper	23/05/135/C21/C21
W120	Jumper	23/04/185/C21/C21
W122	Jumper	23/01/255/C21/C21
W123	Jumper	23/03/165/C21/C21
W124	Jumper	23/02/120/C21/C21
W125	Jumper	23/01/095/C21/C21
W126	Jumper	23/04/115/C21/C21
W127	Jumper	23/01/095/C21/C21
W128	Jumper	23/06/065/C21/C21 (#03, 04)
W129	Jumper	23/03/125/C21/C21
W130	Jumper	23/06/080/C21/C21
W131	Jumper	23/00/120/C21/C21
W132	Jumper	23/08/160/C21/C21
W133	Jumper	IPS-1041-4
W134	Jumper	IPS-1041-4
W135	Jumper	IPS-1041-4
W137	Jumper	RD25UC
W138	Jumper	IPS-1041-4
W139	Jumper	RD25UC
W140	Jumper	IPS-1041-4

[LOGIC UNIT]

REF. NO.	DESCRIPTION	PART NO.
W141	Jumper	IPS-1041-4
W142	Jumper	IPS-1041-4
W143	Jumper	23/07/220/C21/C21
W145	Jumper	RD25UC
W146	Jumper	23/02/245/C21/C21
W147	Jumper	IPS-1041-4
W148	Wire	51/00/450/W11A/A12A (#03 only)
W149	Wire	08 A A (#03 only)
W150	Jumper	IPS-1041-4
W154	Wire	31/00/320/B01/W02
W155	Wire	31/02/320/B01/W02
W156	Wire	31/03/320/B01/W02
W157	Jumper	RD25UC (#02 only)
W158	Jumper	23/03/255/C21/C21 (#02 only)
W167	Jumper	RD25UC
W168	Jumper	RD25UC (#02 only)
W170	Jumper	JPW-02A
W172	Wire	16/01/185/B30/C21
W173	Jumper	JPW-02A
W174	Jumper	JPW-02A
W175	Jumper	23/04/085/C21/C21

[DOUBLER UNIT]

REF. NO.	DESCRIPTION	PART NO.	
Q1	Transistor	2SC2367	
L1	Coil	Press Coil 42383	
L2	Coil	Press Coil 42383	
L3	Coil	Press Coil 42383	
L4	Choke	LAL03NA R27	
R1	Resistor	1k	R10
R2	Resistor	6.8k	R10
R3	Resistor	1k	R10
C1	Cylinder	UP125SL 3R3K	
C2	Ceramic	5P	50V
C3	Ceramic	2P	50V
C4	Trimmer	ECR-MN010C13 10P	
C5	Trimmer	ECR-MN002U13 2P	
C6	Trimmer	ECR-MN002U13 2P	
C7	Feed Through	TF240-602SS332Z 50V	
C8	Feed Through	TF240-602SS332Z 50V	
C9	Ceramic	0.35P	50V
EP1	P.C.B	B-1055	

[DC-DC UNIT]

REF. NO.	DESCRIPTION	PART NO.	
IC1	IC	TC5082P G (#02 only)	
IC2	IC	NJM4558D (#02 only)	
IC3	IC	DP-2	
IC4	IC	TA78L008AP	
Q1	Transistor	2SA1348 (#02 only)	
D2	Diode	1SS53 (#02 only)	
D3	Diode	1SS53	
D4	Diode	1SS53	
X1	Crystal	HC43/U 7.168MHz (#02 only)	
L1	Choke	FL4H 102	
L2	Choke	LW-12	
R2	Resistor	47	R20 (#02 only)
R3	Resistor	3.3k	R20 (#02 only)
R4	Trimmer	H0651A 1k (#02 only)	
R5	Resistor	47k	R20 (#02 only)
R6	Resistor	3.9k	R20 (#02 only)
R7	Resistor	1.8M	R20 (#02 only)
R8	Resistor	220k	R20 (#02 only)
R10	Resistor	4.7k	ELR20 (#02 only)
R11	Resistor	1.8M	R20 (#02 only)
R12	Trimmer	H0651A 47k	
R13	Resistor	22k	R20
R14	Resistor	4.7	ELR20
C1	Ceramic	47P	50V (#02 only)
C2	Ceramic	0.001	50V (#02 only)
C3	Ceramic	0.0047	50V (#02 only)
C4	Electrolytic	10	16V
C5	Ceramic	47P	50V (#02 only)
C6	Ceramic	0.001	50V (#02 only)
C7	Ceramic	0.0047	50V (#02 only)
C8	Electrolytic	10	16V (#02 only)

[DC-DC UNIT]

REF. NO.	DESCRIPTION	PART NO.
C9	Ceramic	12P 50V (#02 only)
C10	Ceramic	12P 50V (#02 only)
C11	Mylar	0.0047 50V (#02 only)
C12	Electrolytic	4.7 25V BP (#02 only)
C13	Ceramic	15P 50V (#02 only)
C14	Electrolytic	0.47 50V (#02 only)
C15	Barrier Layer	0.1 16V
C16	Electrolytic	100 16V
C17	Electrolytic	100 16V
C18	Ceramic	0.001 50V
C19	Barrier Layer	0.1 16V
J1	Connector	B03B-EH-S
J2	Connector	B03B-EH-S
J3	Connector	B04B-EH-S
J4	Connector	TLB-P03H-B1
J5	Connector	RT-01T-1.0B
J8	Connector	RT-01T-1.0B
P1	Connector	EHR-10 (#02 only)
P2	Connector	5250-02 (#02 only)
P3	Connector	EHR-04
P4	Connector	1625-03P1
EP1	P.C.B	B-966C
W2	Wire	23/00/300/B06/C21
W3	Wire	23/08/280/B06/C21
W4	Wire	23/07/270/B06/C21
W5	Wire	51/02/340/A12A/W11A
W6	Wire	08 A A
W7	Wire	23/04/200/B06/C21
W8	Wire	23/03/195/B06/C21
W9	Wire	23/00/160/B06/C21
W10	Wire	23/01/160/B06/C21
W11	Jumper	23/02/065/C21/C21
W12	Wire	16/02/150/C22/A03
W13	Wire	16/00/150/C22/A03
W14	Wire	16/06/150/C22/A03
W15	Jumper	74/98/030/X98/X98

[VCC UNIT]

REF. NO.	DESCRIPTION	PART NO.
IC1	IC	4017
IC2	IC	μPD4175 BC
IC3	IC	4071
IC4	IC	4081
IC5	IC	4001
Q1	Transistor	2SC3399
Q2	Transistor	2SC3399
Q3	Transistor	2SC3399
Q4	Transistor	2SC3399
Q5	Transistor	2SA933X S
Q6	Transistor	2SA933X S
Q7	Transistor	2SA933X S
Q8	Transistor	2SA933X S
D1	Diode	1SS53
D2	Diode	1SS53
D3	Diode	1SS53
D4	Diode	1SS53
D5	Diode	1SS53
R1	Resistor	47k ELR20
R2	Resistor	47k ELR20
R3	Resistor	47k ELR20
R4	Resistor	47k ELR20
R5	Resistor	47k ELR20
R6	Resistor	56k ELR20
R7	Resistor	47k ELR20
R8	Resistor	27k R20
R9	Resistor	27k R20
R10	Resistor	27k R20
R11	Resistor	27k R20
C1	Ceramic	0.0047 50V
J1	Connector	B10B-EH-S
J2	Connector	TLB-P05H-B1
J3	Connector	TLB-P05H-B1
P1	Connector	EHR-10
P2	Connector	EHR-03
P3	Connector	EHR-05
P4	Connector	EHR-03
EP1	P.C.B	B-960B
W1	Jumper	IPS-1041-4
W2	Jumper	IPS-1041-4
W3	Jumper	IPS-1041-4
W4	Jumper	IPS-1041-2
W5	Jumper	IPS-1041-4
W6	Jumper	IPS-1041-4
W7	Jumper	IPS-1041-4
W8	Jumper	IPS-1041-4
W9	Jumper	IPS-1041-4
W10	Jumper	IPS-1041-4

[VCC UNIT]

REF. NO.	DESCRIPTION	PART NO.
W11	Jumper	IPS-1041-4
W12	Jumper	IPS-1041-4
W13	Jumper	IPS-1041-4
W14	Jumper	IPS-1041-2
W15	Jumper	IPS-1041-4
W16	Jumper	IPS-1041-2
W17	Jumper	IPS-1041-4
W18	Jumper	23/04/070/C21/C21
W19	Jumper	23/05/065/C21/C21
W20	Jumper	23/03/055/C21/C21
W21	Wire	23/05/150/B06/C21
W23	Wire	23/02/155/B06/C21
W24	Wire	23/01/225/B06/C21
W25	Wire	23/02/230/B06/C21
W26	Wire	23/03/230/B06/C21
W27	Wire	23/04/235/B06/C21
W28	Wire	23/00/235/B06/C21
W29	Wire	23/02/090/B06/C21
W30	Wire	23/00/090/B06/C21
W31	Wire	23/01/185/B06/C22
W32	Wire	23/02/185/B06/C22
W33	Wire	23/03/180/B06/C22
W34	Wire	23/04/180/B06/C22
W35	Wire	23/05/180/B06/C22
W36	Wire	23/06/185/B06/C22
W37	Wire	23/07/185/B06/C22
W38	Wire	23/08/190/B06/C22
W39	Wire	23/09/190/B06/C22
W40	Wire	23/00/195/B06/C22

[IF UNIT]

REF. NO.	DESCRIPTION	PART NO.
IC1	IC	ND487C1-3R
Q1	FET	3SK101 GR/BL
Q2	FET	2SK241 Y
Q3	Transistor	2SC2026
Q4	Transistor	2SC763 C
Q5	Transistor	2SC3402
Q6	Transistor	2SB596 O
Q7	Transistor	2SC3399
Q8	Transistor	2SC3399
Q9	Transistor	2SC2785 KF
Q10	Transistor	2SC3399
D1	Diode	1SS53
D2	Diode	1SS53
D3	Diode	1SS53
D4	Diode	1SS53
D5	Diode	1SS53
D6	Diode	1SV99
D7	Diode	1SV99
D8	Diode	1SV99
D9	Zener	RD4.7E B2
FI1	Crystal	10M15B7
L1	Coil	LS-66A
L2	Coil	LS-66A
L3	Coil	LR-116
L4	Coil	LR-116
L5	Coil	LS-3A
L6	Coil	LS-3A
L7	Coil	LS-3A
L8	Coil	LS-145
L9	Coil	LS-3A
L10	Coil	LS-3A
L11	Coil	LS-127
L12	Coil	LS-145
L13	Coil	LS-145
L14	Coil	LS-145
L15	Coil	LS-145
L16	Coil	LS-164
L17	Coil	LS-164
L18	Coil	LS-145
L19	Coil	LS-145
L20	Choke	LAL03NA 1ROM
R1	Resistor	2.2k ELR20
R2	Resistor	2.2k R20
R3	Resistor	2.2k ELR20
R4	Resistor	2.2k ELR20
R6	Resistor	2.2k ELR20
R7	Resistor	2.2k R20
R8	Resistor	5.6k R20
R9	Resistor	1k ELR20
R10	Resistor	220 R20
R11	Resistor	2.2k ELR20
R12	Resistor	2.2k ELR20
R13	Resistor	100k ELR20
R14	Resistor	47 R20

[IF UNIT]

REF. NO.	DESCRIPTION	PART NO.	
R15	Resistor	2.2k	R20
R17	Resistor	10M	ERC14GJ
R18	Resistor	47	R20
R19	Resistor	18k	ELR20
R20	Resistor	10k	R20
R21	Resistor	1.2k	ELR20
R22	Resistor	470	R20
R25	Resistor	47	R20
R26	Resistor	1k	R20
R27	Resistor	100	ELR20
R28	Resistor	2.2k	ELR20
R29	Resistor	2.2k	ELR20
R30	Resistor	1k	R20
C1	Ceramic	0.0047	50V
C2	Ceramic	8P	50V
C3	Ceramic	0.0047	50V
C4	Ceramic	0.0047	50V
C5	Ceramic	8P	50V
C6	Ceramic	0.5P	50V
C7	Ceramic	0.5P	50V
C8	Ceramic	7P	50V
C9	Ceramic	7P	50V
C10	Ceramic	0.0047	50V
C11	Ceramic	0.0047	50V
C12	Ceramic	120P	50V
C13	Ceramic	4P	50V
C14	Ceramic	120P	50V
C15	Ceramic	0.0047	50V
C16	Ceramic	0.0047	50V
C17	Ceramic	0.001	50V
C18	Ceramic	0.0047	50V
C19	Ceramic	0.0047	50V
C20	Ceramic	3P	50V TH
C21	Ceramic	6P	50V UJ
C22	Ceramic	0.001	50V
C23	Ceramic	0.0047	50V
C24	Ceramic	8P	50V
C25	Ceramic	8P	50V
C26	Ceramic	0.5P	50V
C27	Ceramic	3P	50V
C28	Ceramic	1P	50V
C29	Ceramic	4P	50V
C30	Electrolytic	1	50V BP
C31	Ceramic	0.001	50V
C32	Ceramic	0.0047	50V
C34	Ceramic	0.001	50V
C35	Ceramic	5P	50V
C36	Ceramic	0.0047	50V
C37	Ceramic	0.0047	50V
C40	Ceramic	0.0047	50V
C41	Ceramic	0.001	50V
C42	Ceramic	0.0047	50V
C43	Ceramic	3P	50V
C45	Ceramic	1P	50V
C46	Ceramic	1P	50V
C47	Ceramic	5P	50V
C48	Ceramic	7P	50V
C49	Ceramic	0.001	50V
C50	Ceramic	0.0047	50V
C51	Electrolytic	10	16V RC2
C52	Ceramic	0.001	50V
C53	Ceramic	0.0047	50V

[IF UNIT]

REF. NO.	DESCRIPTION	PART NO.	
C54	Ceramic	0.001	50V
C55	Ceramic	0.35P	50V
C56	Ceramic	47P	50V
C57	Ceramic	0.001	50V
C58	Ceramic	0.0047	50V
C59	Ceramic	0.0047	50V
C60	Ceramic	9P	50V
C61	Ceramic	9P	50V
C62	Ceramic	0.0047	50V
C63	Ceramic	0.001	50V
C64	Ceramic	0.0047	50V
C65	Ceramic	0.001	50V
C66	Ceramic	0.0047	50V
C67	Ceramic	0.0047	50V
C68	Ceramic	0.0047	50V
C69	Ceramic	0.0047	50V
C70	Ceramic	0.0047	50V
C71	Ceramic	0.0047	50V
C74	Ceramic	12P	50V
C75	Ceramic	0.0047	50V
C76	Ceramic	0.0047	50V
C77	Ceramic	0.001	50V
C78	Ceramic	0.0047	50V
C79	Electrolytic	10	16V RC2
C80	Ceramic	0.0047	50V
C81	Ceramic	0.0047	50V
C82	Ceramic	0.001	50V
C83	Ceramic	0.001	50V
C84	Ceramic	0.001	50V
C85	Ceramic	0.001	50V
C86	Ceramic	0.001	50V
C87	Ceramic	0.001	50V
C88	Ceramic	0.001	50V
C89	Ceramic	0.001	50V
C90	Ceramic	0.001	50V
J1	Connector	B05B-EH-S	
J2	Connector	B05B-EH-S	
J3	Connector	TMP-J01X-V2	
J4	Connector	TMP-J01X-V2	
J5	Connector	TMP-J01X-V2	
J6	Connector	TMP-J01X-V2	
J7	Connector	TMP-J01X-V2	
P1	Connector	EHR-06	
P2	Connector	5250-02	
EP1	P.C.B	B-969B	
EP2	Bead Core	DL2-OP-2.6-3-1.2H	
EP3	Bead Core	FSQ081RL	
W1	Jumper	23/01/060/C21/C21	
W2	Jumper	23/02/075/C21/C21	
W3	Jumper	23/03/040/C21/C21	
W4	Jumper	23/04/070/C21/C21	
W5	Jumper	23/05/090/C21/C21	
W6	Jumper	IPS-1041-2	
W7	Jumper	IPS-1041-2	
W8	Wire	22/01/155/C21/B06	
W9	Wire	23/02/155/C21/B06	

[IF UNIT]

REF. NO.	DESCRIPTION	PART NO.
W10	Wire	23/00/160/C21/B06
W11	Wire	23/03/190/C21/B06
W12	Wire	23/04/160/C21/B06
W13	Wire	23/05/170/C21/B06
W14	Wire	65/99/140/W11A/A12A
W15	Wire	00 A A
W16	Jumper	23/06/065/C21/C21
W17	Jumper	23/07/070/C21/C21
W18	Jumper	IPS-1041-2
W19	Jumper	IPS-1041-2
W20	Jumper	74/98/050/X98/X98
W21	Jumper	74/98/025/X98/X98
W22	Jumper	72/98/025/X98/X98
W23	Jumper	IPS-1041-2
W24	Jumper	74/98/025/X98/X98

[FILTER UNIT]

REF. NO.	DESCRIPTION	PART NO.
L1	Coil	LA-183
C1	Trimmer	ECR-MN002U13 2P
C2	Trimmer	ECR-MN002U13 2P
C3	Ceramic	0.75P 50V
C4	Feed Through	TF-240-602SS332Z
C5	Ceramic	47P 50V
C6	Ceramic	0.001 50V
C7	Ceramic	0.0047 50V
C8	Cylinder	UP050SL 2R2K
C9	Barrier Layer	0.047 25V
C10	Monolithic	0.001 GR42-6
J1	Connector	B03B-EH-S
P1	Connector	TMP-P01X-A1
EP1	P.C.B	B-970B
W1	Wire	62/99/105/C31/W99
W2	Wire	08 Y
W3	Wire	67/99/240/W99/W99
W4	Wire	08 Y Y
W5	Jumper	72/98/025/X98/X98

[RF MIX UNIT]

REF. NO.	DESCRIPTION	PART NO.	
Q1	FET	MGF1202	
Q2	Transistor	2SC2367	
Q3	Transistor	2SC2367	
Q4	Transistor	2SC2367	
Q5	Transistor	2SC2367	
Q6	Transistor	2SC2367	
D1	Diode	1SS99	
D2	Diode	1SS53	
L1	Coil	LA-156	
L2	Coil	LA-156	
L3	Coil	LA-233	
L4	Coil	LA-233	
L5	Coil	LA-233	
L6	Coil	Press Coil 42383	
L7	Coil	Press Coil 42383	
L8	Coil	Press Coil 42383	
L9	Coil	Press Coil 42383	
L10	Coil	Press Coil 42383	
L11	Coil	Press Coil 42383	
L12	Coil	Press Coil 42383	
L13	Coil	Press Coil 42383	
L14	Coil	Press Coil 42383	
L15	Coil	Press Coil 42383	
R1	Chip	100	MCR10
R2	Resistor	100	R20
R3	Resistor	1k	R20
R4	Resistor	4.7k	R20
R5	Resistor	220	R20
R6	Resistor	220	R20
R7	Resistor	4.7k	R20
R8	Resistor	1k	R20
R9	Resistor	4.7k	R20
R10	Resistor	1k	R20
R11	Resistor	4.7k	R20
R12	Resistor	1k	R20
R13	Resistor	2.2k	R20
R14	Resistor	1k	R20
R15	Trimmer	H0651A	10k
R16	Resistor	47	R20
R17	Resistor	1k	R20
R18	Resistor	47	R20
R19	Trimmer	H0651A	10k
R20	Resistor	1k	R20
R21	Trimmer	H0651A	33k
R22	Trimmer	H0651A	33k
R23	Resistor	68	R20
R24	Trimmer	H0651A	10k
R25	Resistor	68	R20
R26	Resistor	47	R20
R27	Resistor	100	MCR18
C1	Trimmer	ECR-MN002U13 2P	
C2	Monolithic	0.001	GRM40
C3	Monolithic	0.001	GRM40
C4	Trimmer	ECR-MN002U13 2P	
C5	Ceramic	1P	50V
C6	Ceramic	1P	50V

[RF MIX UNIT]

REF. NO.	DESCRIPTION	PART NO.	
C7	Ceramic	2P	50V
		(#02, 03, 04)	
C8	Trimmer	ECR-MN002U13 2P	
C9	Ceramic	10P	50V
C10	Trimmer	ECR-MN002U13 2P	
C11	Ceramic	2P	50V
C12	Ceramic	1P	50V
C13	Trimmer	ECR-MN002U13 2P	
C14	Ceramic	10P	50V
C15	Ceramic	1P	50V
C16	Ceramic	5P	50V
C17	Trimmer	ECR-MN002U13 2P	
C18	Ceramic	1P	50V CK
C19	Ceramic	0.75P	50V
C20	Ceramic	1P	50V CK
C21	Trimmer	ECR-MN002U13 2P	
C22	Trimmer	ECR-MN002U13 2P	
C23	Ceramic	1P	50V CK
C24	Ceramic	2P	50V CK
C25	Trimmer	ECR-MN002U13 2P	
C26	Ceramic	0.75P	50V
C27	Ceramic	2P	50V
C28	Trimmer	ECR-MN002U13 2P	
C29	Feed Through	TF-240-602SS332Z	
		50V	
C30	Monolithic	0.001	GRM40
C31	Monolithic	0.001	GRM40
C32	Feed Through	TF-240-602SS332Z	
		50V	
C33	Feed Through	TF-240-602SS332Z	
		50V	
C34	Ceramic	47P	50V
C35	Ceramic	0.001	50V
C36	Ceramic	15P	50V
C37	Feed Through	TF-240-602SS332Z	
		50V	
C38	Feed Through	TF-240-602SS332Z	
		50V	
C39	Ceramic	33P	50V
C40	Feed Through	TF-240-602SS332Z	
		50V	
C41	Feed Through	TF-240-602SS332Z	
		50V	
C42	Feed Through	TF-240-602SS332Z	
		50V	
C43	Feed Through	TF-240-602SS332Z	
		50V	
C44	Feed Through	TF-240-602SS332Z	
		50V	
C45	Feed Through	TF-240-602SS332Z	
		50V	
C46	Ceramic	0.001	50V
C47	Ceramic	47P	50V
C48	Ceramic	47P	50V
C49	Ceramic	0.001	50V
C50	Ceramic	47P	50V
C51	Ceramic	0.35P	50V
C52	Monolithic	0.001	GRM40
C53	Feed Through	TF-240-602SS332Z	
		50V	
J1	Connector	TMP-J01X-A2	
J2	Connector	TMP-J01X-A2	

[RF MIX UNIT]

REF. NO.	DESCRIPTION	PART NO.
J3	Connector	TMP-J01X-A2
J4	Connector	B02B-EH-S
P1	Connector	TMP-P01X-A1
P2	Connector	EHR-05
P3	Connector	TMP-P01X-A1
EP1	P.C.B	B-988A
W1	Wire	23/01/180/C21/B06
W2	Wire	23/02/155/C21/B06
W3	Wire	23/03/125/C21/B06
W4	Wire	23/00/175/C21/B06
W7	Wire	62/99/070/C31/W18X
W8	Wire	08 X
W10	Jumper	72/98/050/X98/X98
W11	Jumper	72/98/050/X98/X98
W12	Jumper	72/98/025/X98/X98
W13	Jumper	72/98/025/X98/X98
W14	Jumper	72/98/025/X98/X98
W15	Wire	62/99/110/C31/W18X
W16	Wire	08 X
W17	Wire	23/04/100/C21/B06
W18	Jumper	74/98/025/X98/X98
W19	Jumper	72/98/025/X98/X98

[PA-M UNIT]

REF. NO.	DESCRIPTION	PART NO.
IC1	IC	SC-1040
IC2	IC	NJM7809A
IC3	IC	NJM4558D
IC4	IC	NJM4558D
IC5	IC	μA7805C
Q1	Transistor	2SC2558K
Q2	Transistor	2SC945 K
Q3	Transistor	2SD359
Q4	Transistor	2SC945 Q/P/K
Q5	Transistor	2SC945 Q/P/K
Q6	Transistor	2SC2120 Y
Q7	Transistor	2SD468 C
D1	Diode	1S953
D2	Diode	1SS237
D3	Diode	1N4002
D4	Diode	1SS53
D5	Diode	1SS53
D6	Diode	1SS237
D7	Diode	1SS237
D8	Diode	1SS53
D9	Diode	15CD11
L1	Coil	Press Coil 42383
L2	Coil	Press Coil 42383
L3	Coil	Press Coil 42383
L4	Coil	LW-4
L5	Coil	LA-150
L6	Coil	LA-95
L7	Coil	Press Coil 42383
L8	Coil	Press Coil 42383
L9	Coil	LAL03NA R22M
R1	Resistor	22 ELR20
R2	Resistor	150 R25
R3	Resistor	RGB3 0.15
R4	Resistor	100k ELR20
R5	Resistor	220 ELR20
R6	Trimmer	RHB0C1204A 100
R7	Resistor	1k R20
R8	Resistor	1k ELR20
R9	Resistor	47k ELR20
R10	Resistor	47k ELR20
R11	Resistor	12k ELR20
R12	Resistor	10k ELR20
R13	Resistor	220k ELR20
R14	Resistor	100 ELR20
R15	Trimmer	RHB0CS32UA 4.7k
R16	Resistor	1k ELR20
R17	Resistor	1k R20
R18	Resistor	220k ELR20
R20	Resistor	15k ELR20
R21	Resistor	47 ELR20
R22	Resistor	3.3k ELR20
R23	Trimmer	RHB0CJ30EA 2.2k
R24	Trimmer	RHB0CS42BA 47k
R25	Resistor	100k ELR20
R26	Resistor	220k ELR20
R27	Resistor	100 ELR20

[PA-M UNIT]

REF. NO.	DESCRIPTION	PART NO.	
R28	Resistor	10k	ELR20
R29	Resistor	4.7M	ERC14GJ
R30	Resistor	2.2M	R20
R31	Resistor	330k	R20
R32	Resistor	47	R20
R33	Resistor	2.2M	R20
R34	Resistor	1k	R20
R35	Resistor	10	R50X
R36	Resistor	10	R50X
R37	Resistor	470	ELR20
R38	Resistor	3.3k	ELR20
R39	Resistor	680	R25
R40	Resistor	2.2k	ELR20
R41	Resistor	68	R25
R42	Resistor	1k	R20
C1	Ceramic	0.75P	50V
C2	Trimmer	ECR-MN002U13 2P	
C3	Trimmer	ECR-MN002U13 2P	
C4	Trimmer	ECR-MN002U13 2P	
C5	Ceramic	0.5P	50V
C6	Ceramic	0.001	50V
C7	Feed Through	TF318-450 E 102	
C8	Ceramic	0.001	50V
C9	Monolithic	1P	GR42-6 CH
C10	Trimmer	ECR-MN002U12 2P	
C11	Ceramic	0.001	50V
C12	Electrolytic	10	16V MS7
C13	Feed Through	TF318-450 E 102	
C14	Trimmer	ECR-MN002U12 2P	
C15	Monolithic	10P	GR42-6 CH
C16	Ceramic	0.001	50V
C17	Electrolytic	470	16V
C18	Ceramic	0.001	50V
C19	Ceramic	47P	50V
C20	Ceramic	47P	50V
C21	Ceramic	0.001	50V
C22	Ceramic	47P	50V
C23	Ceramic	0.001	50V
C24	Electrolytic	100	16V
C25	Ceramic	0.001	50V
C26	Electrolytic	10	16V MS7
C27	Electrolytic	10	16V MS7
C28	Ceramic	0.001	50V
C29	Ceramic	47P	50V
C30	Ceramic	4P	50V
C31	Monolithic	UC232H030D 3P	
C32	Monolithic	1P	GR42-6 CH
C33	Trimmer	ALL	3P
C34	Trimmer	ALL	3P
C35	Monolithic	0.75P	GR42-6 CH
C36	Ceramic	47P	50V
C37	Ceramic	4P	50V
C38	Ceramic	0.001	50V
C39	Ceramic	0.001	50V
C40	Monolithic	1P	GR42-6 CH
C41	Ceramic	0.001	50V
C42	Ceramic	0.001	50V
C43	Ceramic	0.001	50V
C44	Ceramic	0.001	50V
C45	Ceramic	0.001	50V

[PA-M UNIT]

REF. NO.	DESCRIPTION	PART NO.	
C46	Ceramic	0.001	50V
C47	Ceramic	4P	50V
C48	Ceramic	4P	50V
C49	Ceramic	0.001	50V
C50	Ceramic	4P	50V
C51	Ceramic	0.001	50V
C52	Ceramic	0.001	50V
C53	Ceramic	0.001	50V
C54	Ceramic	4P	50V
C55	Ceramic	0.001	50V
C56	Ceramic	4P	50V
C57	Ceramic	0.001	50V
C58	Ceramic	0.001	50V
C59	Ceramic	0.001	50V
C60	Ceramic	0.001	50V
C61	Ceramic	47P	50V
C62	Feed Through	TF-240-602SS332Z	
C63	Feed Through	TF-240-602SS332Z	
C64	Feed Through	TF-240-602SS332Z	
C65	Feed Through	TF-240-602SS332Z	
C66	Feed Through	TF-240-602SS332Z	
C67	Ceramic	0.001	50V
C68	Ceramic	470P	50V
C69	Ceramic	4P	50V
C70	Ceramic	0.001	50V
C71	Ceramic	4P	50V
C72	Ceramic	0.001	50V
C73	Ceramic	4P	50V
C74	Electrolytic	0.47	50V MS7
C75	Ceramic	0.001	50V
C76	Ceramic	0.001	50V
C77	Ceramic	0.001	50V
C78	Ceramic	0.001	50V
C79	Ceramic	0.001	50V
C80	Ceramic	0.001	50V
C81	Ceramic	0.001	50V
C82	Ceramic	0.001	50V
C83	Ceramic	0.001	50V
C84	Ceramic	0.0047	50V
C85	Barrier Layer	0.047	25V
C86	Ceramic	47P	50V
C87	Ceramic	0.001	50V
C88	Ceramic	0.001	50V
C89	Ceramic	0.001	50V
C90	Ceramic	0.0047	50V
C91	Electrolytic	2.2	50V MS7
C92	Ceramic	0.001	50V
C93	Ceramic	0.001	50V
C94	Electrolytic	1	50V MS5
C95	Ceramic	0.001	50V
C96	Ceramic	0.001	50V
C97	Ceramic	0.001	50V
C98	Ceramic	0.001	50V
C99	Ceramic	0.001	50V
C100	Ceramic	0.001	50V
C101	Electrolytic	10	16V MS5
C102	Electrolytic	0.33	50V MS7
C103	Barrier Layer	0.1	16V
C104	Ceramic	0.001	50V

[PA-M UNIT]

REF. NO.	DESCRIPTION	PART NO.
C105	Ceramic	0.001 50V
C106	Ceramic	0.0047 50V
C107	Electrolytic	100 16V
C108	Ceramic	15P 50V CH
C109	Monolithic	1P GR42-6 CH
RL1	Relay	CX-1054(N)
J1	Connector	TLB-P04H-B1
J2	Connector	TLB-P07H-B1
J3	Connector	TLB-P05H-B1
J4	Connector	TLB-P08H-B1
J5	Connector	RT-01T-1.0B
J6	Connector	SQ-2054
J7	Connector	006P-1300
J8	Connector	5045-02A
J9	Connector	AT-700
J10	Connector	AT-700
J11	Connector	SJ-296
J12	Connector	HSJ0707-01-010
J13	Connector	LLR-6
J14	Connector	RT-01T-1.0B
J15	Connector	RT-01T-1.0B
P1	Connector	TMP-P01X-A1
P2	Connector	5250-02
P3	Connector	EHR-03
P4	Connector	1625-03R1
P5	Connector	1625-02R1
P6	Connector	EHR-05
P7	Connector	EHR-02
P8	Connector	EHR-07
P9	Connector	SMP-03V-B
P10	Connector	TMP-P01X-A1
P11	Connector	TMP-P01X-A1
P12	Connector	001T-4100
P13	Connector	5250-02
P14	Connector	SMP-04V-B
SP1	Speaker	C065K12I0810
MF1	DC Motor	M6B12U22
EP1	P.C.B	B-1083A
EP2	P.C.B	B-981B
EP3	Bead Core	DL2-OP-2.6-3-1.2H
EP4	Bead Core	DL2-OP-2.6-3-1.2H
EP5	Bead Core	DL2-OP-2.6-3-1.2H
EP6	ACC Cable	OPC-047
W1	Wire	23/01/520/B06/C22
W2	Wire	16/06/500/A04/C22
W3	Wire	16/00/500/A04/C22
W4	Wire	23/04/495/A04/C22
W5	Wire	23/00/495/A04/C22
W6	Wire	23/06/410/B06/C22
W7	Wire	23/00/410/B06/C22

[PA-M UNIT]

REF. NO.	DESCRIPTION	PART NO.
W8	Wire	51/02/755/A12A/C22
W9	Wire	08 A A
W10	Wire	13/02/065/W04/B03
W11	Wire	13/02/065/W04/B03
W12	Wire	13/00/065/W04/B03
W13	Wire	13/00/065/W04/B03
W14	Wire	14/01/120/B02/B03
W15	Wire	14/03/120/B02/B03
W16	Wire	23/08/520/B06/C22
W17	Wire	23/09/510/B06/C22
W18	Wire	23/00/440/B06/C22
W19	Wire	23/01/510/B06/C22
W20	Wire	23/02/440/B06/C22
W21	Wire	22/00/495/B06/C22
W22	Wire	23/04/595/B06/C22
W23	Wire	14/02/110/W04/B02
W24	Wire	23/06/485/W03/C22
W25	Wire	23/07/595/B06/C22
W26	Wire	23/08/600/B06/C22
W27	Wire	23/09/420/B06/W03
W28	Wire	23/00/530/B06/C22
W30	Wire	44/02/140/W04/W04
W31	Wire	44/00/140/W04/W04
W32	Wire	67/99/170/W99Y/W99Y
W33	Wire	08 Y Y
W34	Wire	74/98/060/X98/X98
W35	Wire	62/99/300/C31/W99Y
W36	Wire	08 Y
W37	Wire	23/01/115/C21/W01
W38	Wire	23/03/120/C21/W01
W39	Wire	23/04/100/C21/W01
W40	Wire	62/99/280/C31/W17D
W41	Wire	08 D
W42	Wire	62/99/290/C31/W17D
W43	Wire	08 D
W44	Wire	31/02/125/B02/W02
W45	Wire	31/00/140/B02/W02
W46	Wire	31/03/125/B02/W02
W47	Wire	23/00/160/C21/W02
W48	Wire	31/00/240/A12/W02
W49	Wire	31/04/240/A12/W02
W50	Wire	13/12/565/W04/W04
W51	Wire	16/02/490/A04/C22
W52	Wire	23/03/560/C22/W03
W54	Wire	22/02/515/C21/B06
W55	Wire	22/05/190/C21/C32
W56	Wire	23/02/070/C21/W01
W57	Wire	23/05/075/C21/W01
W58	Wire	23/01/045/C21/W01
W59	Wire	23/03/050/C21/W01
W61	Wire	23/02/065/C21/W01
W62	Wire	23/05/130/C21/W01
W63	Wire	66/99/085/C21G/W99X
W64	Wire	08 C21G/W99X
W65	Wire	75/98/020/X98/X98

[PA-TR UNIT]

REF. NO.	DESCRIPTION	PART NO.
IC1	IC	NJM4558D
IC2	IC	NJM4558D
IC3	IC	μA7805C
IC4	IC	NJM7809A
Q2	Transistor	2SC2558K
Q3	Transistor	MTH275
Q4	Transistor	MTH276
Q5	Transistor	MTH277
Q6	Transistor	2SC945 K
Q7	Transistor	2SD359
Q8	Transistor	2SC945 Q/P/K
Q9	Transistor	2SC945 Q/P/K
Q10	Transistor	2SC2120 Y
Q11	Transistor	2SD468 C
D1	Diode	1S953
D2	Diode	1S953
D3	Diode	1S953
D4	Diode	1N4002
D6	Diode	1SS99
D7	Diode	1N4002
D8	Diode	1SS53
D9	Diode	1SS53
D10	Diode	1SS237
D12	Diode	15CD11
D13	Diode	1SS53
D14	Diode	1SS237
L1	Coil	LW-4
L2	Coil	LW-4
L3	Coil	LW-4
L4	Coil	LW-4
L5	Coil	LA-150
L6	Coil	LA-170A
L7	Coil	LA-150
L8	Coil	LA-95
L9	Coil	LA-150
L10	Coil	LA-95
L11	Coil	LA-150
L12	Coil	LA-95
L13	Coil	Press Coil 42383
L14	Coil	Press Coil 42383
L15	Coil	Press Coil 42383
L16	Coil	Press Coil 42383
L17	Coil	Press Coil 42383
L18	Coil	LAL03NA R22M
R1	Resistor	22 ELR20
R2	Resistor	150 R25
R3	Resistor	5.6 ELR20
R4	Resistor	56 R25
R5	Resistor	5.6 ELR20
R6	Resistor	56 R25
R7	Resistor	6.8 ELR25
R8	Resistor	100 R50X
R9	Resistor	RGC3 0.33-K
R12	Resistor	220 ELR20
R13	Trimmer	H0651A 100
R14	Resistor	1k R20

[PA-TR UNIT]

REF. NO.	DESCRIPTION	PART NO.
R15	Resistor	47k ELR20
R16	Resistor	8.2k ELR20
R17	Resistor	1M ELR20
R18	Resistor	1k ELR20
R19	Resistor	1k R20
R20	Resistor	220k ELR20
R21	Resistor	3.3k ELR20
R22	Resistor	100 R20
R23	Resistor	47k ELR20
R25	Resistor	47k ELR20
R26	Resistor	12k ELR20
R28	Resistor	10k R20
R29	Resistor	1M ELR20
R30	Resistor	47 ELR20
R31	Resistor	820k R20
R32	Resistor	2.2M ELR20
R33	Resistor	2.2M R20
R34	Resistor	18k ELR20
R35	Trimmer	H0651A 2.2k
R36	Trimmer	H0651A 47k
R37	Resistor	220k ELR20
R39	Resistor	1k ELR20
R40	Resistor	RSS1P3.3-J
R41	Resistor	470 ELR20
R42	Resistor	3.3k ELR20
R43	Resistor	1k ELR20
R44	Resistor	68 R25
R45	Resistor	2.2k R20
R47	Resistor	1k R20
R48	Trimmer	H0651A 4.7k
R49	Resistor	3.3k ELR20
R50	Resistor	680 R25
R51	Resistor	100 R50X
C1	Ceramic	0.001 50V
C2	Electrolytic	10 16V MS7
C3	Ceramic	0.001 50V
C4	Electrolytic	10 16V MS7
C5	Ceramic	0.001 50V
C6	Electrolytic	10 16V MS7
C7	Ceramic	0.001 50V
C8	Electrolytic	33 16V
C9	Trimmer	ECR-MN002U13 2P
C10	Trimmer	ECR-MN002U13 2P
C11	Trimmer	ECR-MN002U13 2P
C12	Trimmer	ECR-MN004Y12 4P
C13	Monolithic	1P GR42-6 CH
C14	Feed Through	TF318-450 E 102 GMV 50V
C16	Trimmer	ECR-MN004Y12 4P
C17	Feed Through	TF318-450 E 102 GMV 50V
C18	Monolithic	2P GR42-6 CH
C21	Feed Through	TF318-450 E 102 GMV 50V
C23	Trimmer	ECR-MN004Y12 4P
C24	Feed Through	TF318-450 E 102 GMV 50V
C25	Monolithic	3P GR42-6 CH
C26	Monolithic	2P GR42-6 CH
C27	Trimmer	ECR-MN004Y12 4P
C28	Feed Through	TF318-450 E 102 GMV 50V

[PA-TR UNIT]

REF. NO.	DESCRIPTION	PART NO.
C29	Monolithic	2P GR42-6 CH
C30	Trimmer	ECR-MN004Y12 4P
C31	Feed Through	TF318-450 E 102 GMV 50V
C32	Monolithic	5P GR42-6 CH
C33	Monolithic	3P GR42-6 CH
C34	Trimmer	ECR-MN004Y12 4P
C35	Feed Through	TF318-450 E 102 GMV 50V
C36	Monolithic	2P GR42-6 CH
C37	Trimmer	ECR-MN004Y12 4P
C38	Feed Through	TF318-450 E 102 GMV 50V
C39	Trimmer	ECR-MN004Y12 4P
C40	Trimmer	ALL 3P
C41	Trimmer	ALL 3P
C43	Ceramic	0.001 50V
C44	Monolithic	0.5P GR40 CH
C47	Ceramic	0.001 50V
C49	Ceramic	0.001 50V
C51	Ceramic	0.001 50V
C53	Ceramic	470P 50V
C54	Ceramic	0.001 50V
C55	Ceramic	0.0047 50V
C56	Ceramic	0.001 50V
C57	Ceramic	0.001 50V
C58	Ceramic	0.001 50V
C59	Electrolytic	3.3 50V MS7
C60	Electrolytic	0.33 50V RC2
C61	Barrier Layer	0.1 16V
C62	Ceramic	0.001 50V
C63	Ceramic	0.001 50V
C64	Ceramic	0.0047 50V
C66	Ceramic	0.001 50V
C68	Electrolytic	1 50V MS7
C69	Ceramic	0.001 50V
C71	Ceramic	0.001 50V
C72	Ceramic	0.001 50V
C73	Ceramic	0.001 50V
C74	Ceramic	0.001 50V
C75	Ceramic	0.001 50V
C76	Ceramic	0.001 50V
C78	Ceramic	0.001 50V
C79	Ceramic	0.001 50V
C80	Ceramic	0.001 50V
C81	Ceramic	0.001 50V
C82	Ceramic	0.001 50V
C83	Ceramic	0.001 50V
C84	Ceramic	0.001 50V
C85	Ceramic	0.001 50V
C86	Ceramic	0.001 50V
C87	Ceramic	0.001 50V
C88	Ceramic	0.001 50V
C89	Ceramic	0.001 50V
C90	Ceramic	0.001 50V
C91	Ceramic	0.001 50V
C92	Ceramic	0.001 50V
C93	Ceramic	0.001 50V
C94	Ceramic	0.75P 50V
C95	Ceramic	0.5P 50V
C96	Monolithic	2P GR42-6 CH
C97	Trimmer	ECR-MN004Y12 4P
C98	Monolithic	2P GR42-6 CH
C99	Monolithic	3P GR42-6 CH

[PA-TR UNIT]

REF. NO.	DESCRIPTION	PART NO.
C100	Monolithic	2P GR42-6 CH
C101	Ceramic	0.001 50V
C102	Ceramic	0.001 50V
C103	Ceramic	0.001 50V
C104	Ceramic	0.001 50V
C105	Ceramic	0.001 50V
C106	Ceramic	0.001 50V
C107	Electrolytic	0.47 50V MS7
C108	Ceramic	0.001 50V
C109	Electrolytic	10 16V MS5
C110	Ceramic	0.5P 50V CH
C111	Ceramic	0.75P 50V
C112	Ceramic	0.001 50V
C113	Ceramic	0.001 50V
C114	Ceramic	0.001 50V
C116	Trimmer	ECR-MN002U12 2P
C117	Electrolytic	2.2 50V MS5
C118	Electrolytic	10 16V MS5
C119	Ceramic	4P 50V
C120	Electrolytic	100 16V
RL1	Relay	CX-1054(N)
J1	Connector	AT-700
J2	Connector	AT-700
J5	Connector	TLB-P08H-B1
J6	Connector	006P-1300
J7	Connector	SJ-296
J8	Connector	HSJ0707-01-010
J9	Connector	5045-02A
J10	Connector	TLB-P04H-B1
J11	Connector	LLR-6
J12	Connector	SQ-2054
J13	Connector	TLB-P06H-B1
J14	Connector	TLB-P05H-B1
J15	Connector	RT-01T-1.0B
P2	Connector	TMP-P01X-A1
P3	Connector	TMP-P01X-A1
P4	Connector	TMP-P01X-A1
P8	Connector	EHR-07
P9	Connector	5250-02
P10	Connector	SMP-03V-B
P11	Connector	SMP-04V-B
P12	Connector	EHR-03
P13	Connector	5250-02
P14	Connector	EHR-05
P15	Connector	1625-03R1
P17	Connector	EHR-02
P18	Connector	1625-02R1
P19	Connector	001T-4100
SP1	Speaker	C065K1210810
MF1	DC Motor	M6B12U22
EP1	P.C.B	B-967A
EP2	P.C.B	B-981A

[PA-TR UNIT]

REF. NO.	DESCRIPTION	PART NO.
EP3	Bead Core	DL2-OP-2.6-3-1.2H
EP4	Bead Core	DL2-OP-2.6-3-1.2H
EP5	Bead Core	DL2-OP-2.6-3-1.2H
EP6	Bead Core	DL2-OP-2.6-3-1.2H
EP7	Bead Core	DL2-OP-2.6-3-1.2H
EP8	Bead Core	DL2-OP-2.6-3-1.2H
EP9	Bead Core	DL2-OP-2.6-3-1.2H
EP10	Bead Core	DL2-OP-2.6-3-1.2H
EP11	ACC Cable	OPC-047
EP13	Bead Core	DL2-OP-2.6-3-1.2H
W1	Wire	23/01/495/B06/C22
W2	Wire	16/06/395/A04/C22
W3	Wire	16/00/395/A04/C22
W4	Wire	23/04/420/A04/C22
W5	Wire	23/00/420/A04/C22
W6	Wire	23/06/415/B06/C22
W7	Wire	23/00/410/B06/C22
W8	Wire	[51/02/730/A12A/C22A
W9	Wire	[02 A A
W10	Wire	13/02/065/W04/B03
W11	Wire	13/02/065/W04/B03
W12	Wire	13/00/065/W04/B03
W13	Wire	13/00/065/W04/B03
W14	Wire	14/01/120/B02/B03
W15	Wire	14/03/120/B02/B03
W16	Wire	23/08/495/B06/C22
W17	Wire	23/09/495/B06/C22
W18	Wire	23/00/410/B06/C22
W19	Wire	23/01/475/B06/C22
W20	Wire	23/02/410/B06/C22
W21	Wire	22/00/470/B06/C22
W22	Wire	23/04/540/B06/C22
W23	Wire	14/02/110/W04/B02
W24	Wire	23/06/420/W03/C22
W25	Wire	23/07/535/B06/C22
W26	Wire	23/08/540/B06/C22
W27	Wire	23/09/420/B06/W03
W28	Wire	23/00/500/B06/C22
W30	Wire	44/02/150/W04/W04
W31	Wire	44/00/150/W04/W04
W32	Wire	[67/99/210/W99Y/W99Y
W33	Wire	[08 Y Y
W34	Wire	73/98/060/X98/X98
W35	Wire	[62/99/295/C31/W99Y
W36	Wire	[08 Y
W37	Wire	23/01/105/C21/C21
W38	Wire	23/03/100/C21/C21
W39	Wire	23/04/090/C21/C21
W40	Wire	[62/99/280/C31/W17D
W41	Wire	[08 D
W42	Wire	[62/99/290/C31/W17D
W43	Wire	[08 D
W44	Wire	31/02/125/B02/W02
W45	Wire	31/00/140/B02/W02
W46	Wire	31/03/125/B02/W02
W47	Wire	23/00/160/C21/W02
W48	Wire	31/00/240/A12/W02
W49	Wire	31/04/240/A12/W02
W50	Wire	13/00/080/W04/W04
W51	Wire	16/02/380/A04/C22
W52	Wire	23/02/355/C22/W03
W53	Wire	23/05/075/C21/C21

[PA-TR UNIT]

REF. NO.	DESCRIPTION	PART NO.
W54	Wire	22/02/515/C21/B06
W55	Wire	22/05/190/C21/C32

IC-1271A SCHEMATIC DIAGRAM

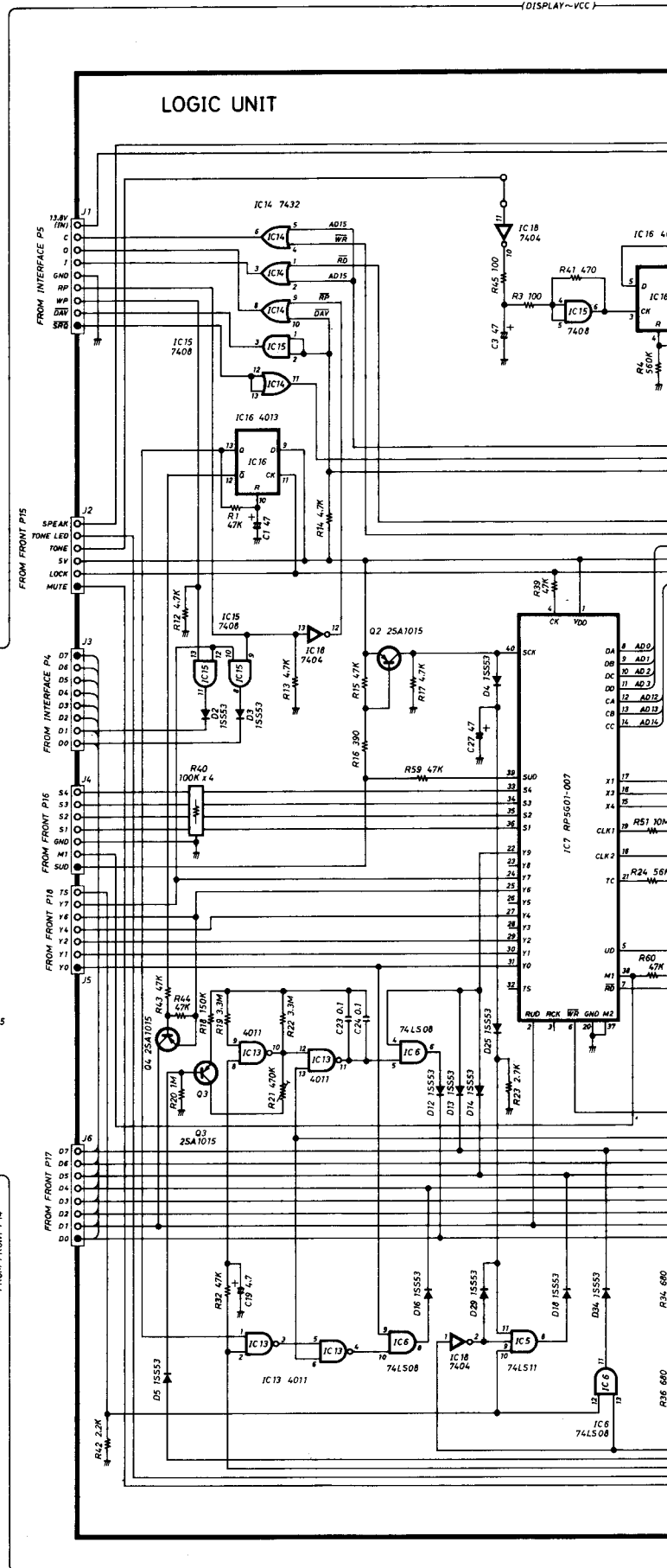
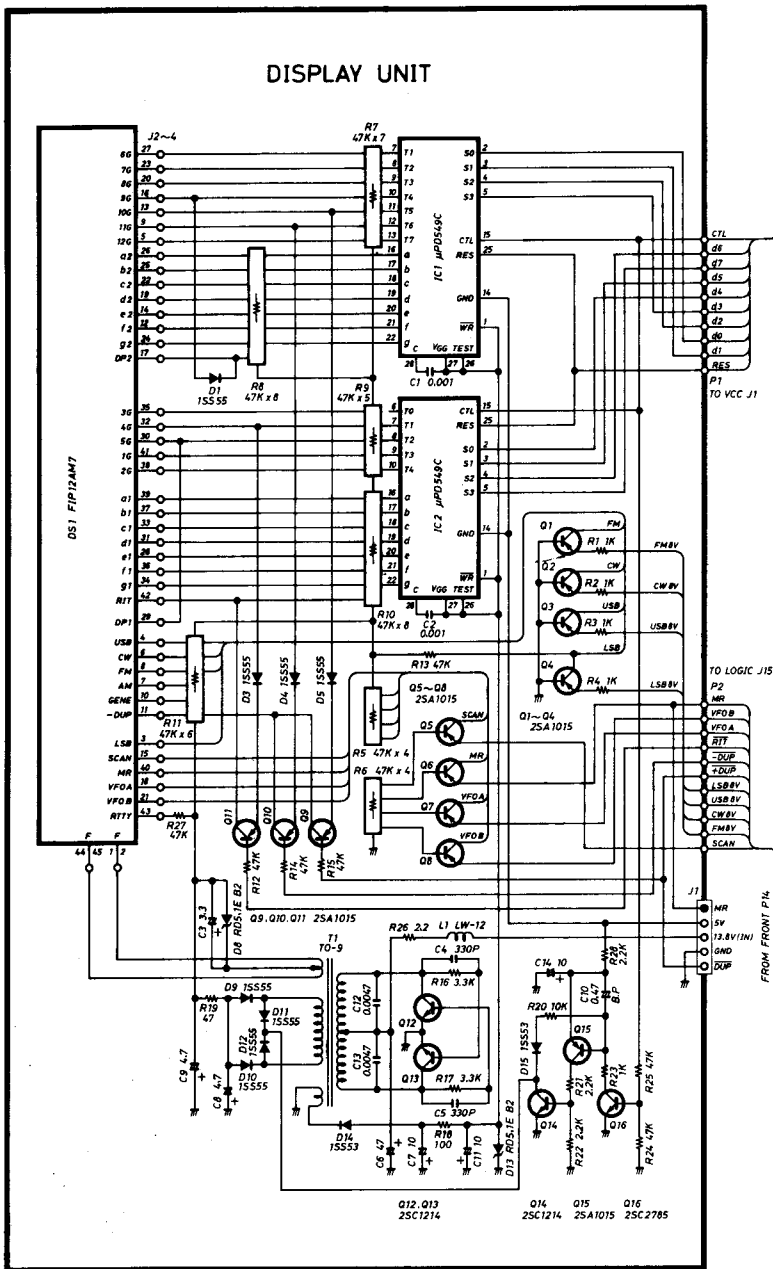

DIAGRAM

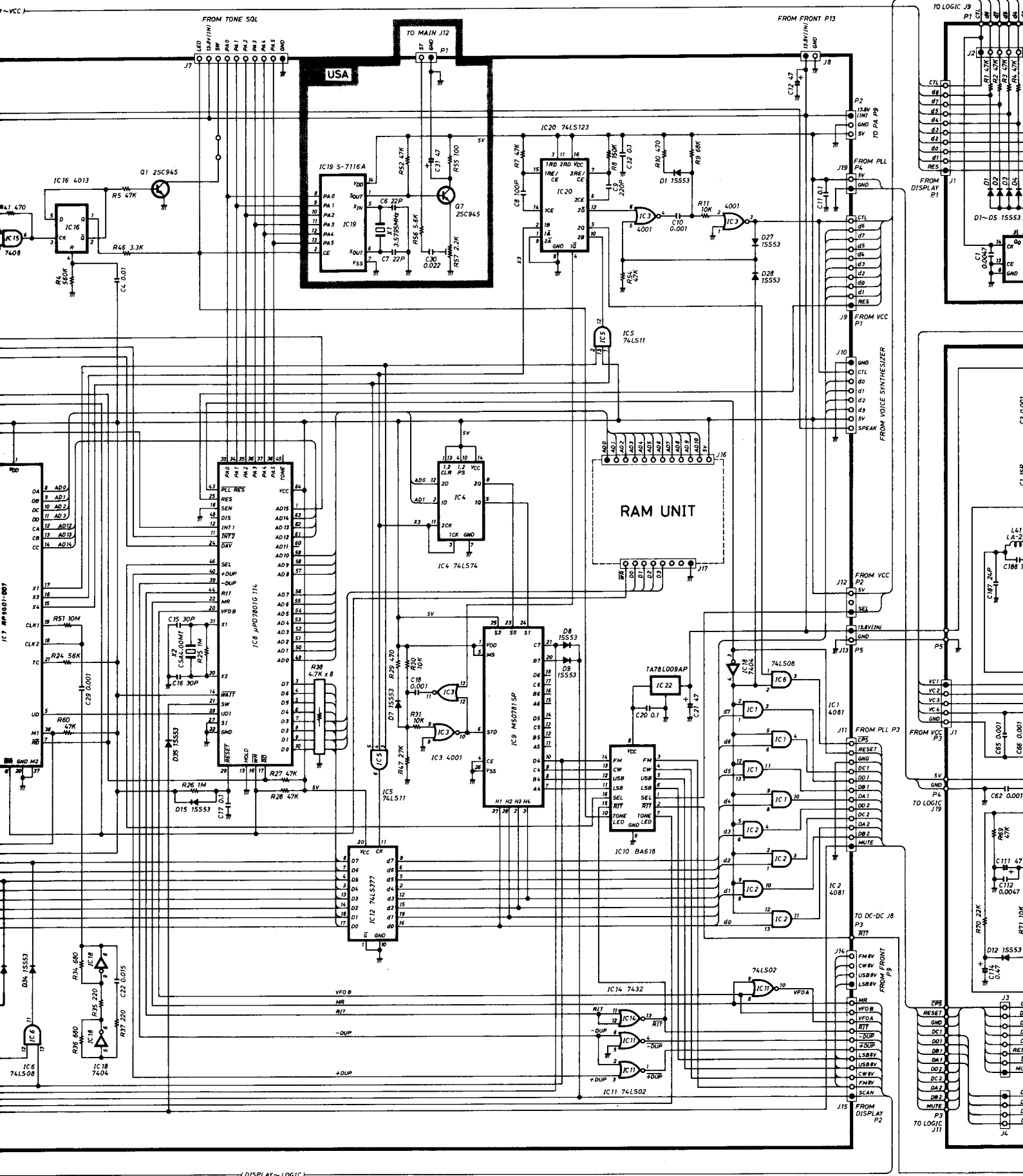

(DISPLAY - LOGIC)

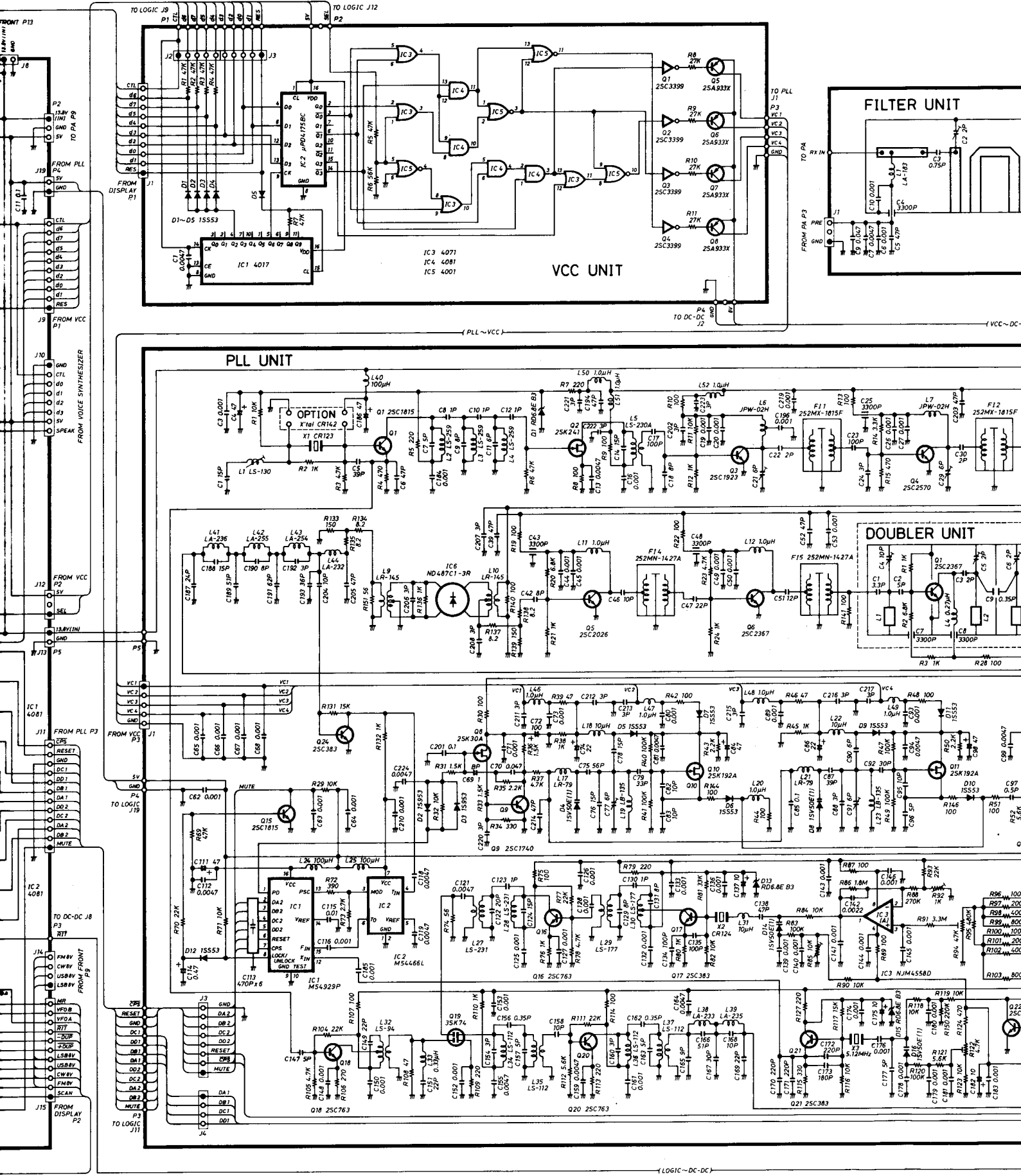

VCC UNIT

PLL UNIT

FILTER UNIT

DOUBLER UNIT

(LOGIC - DC - DC)

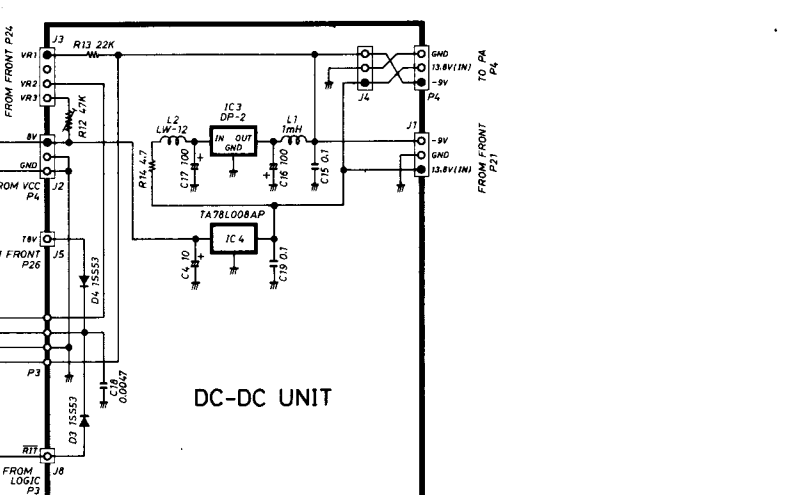
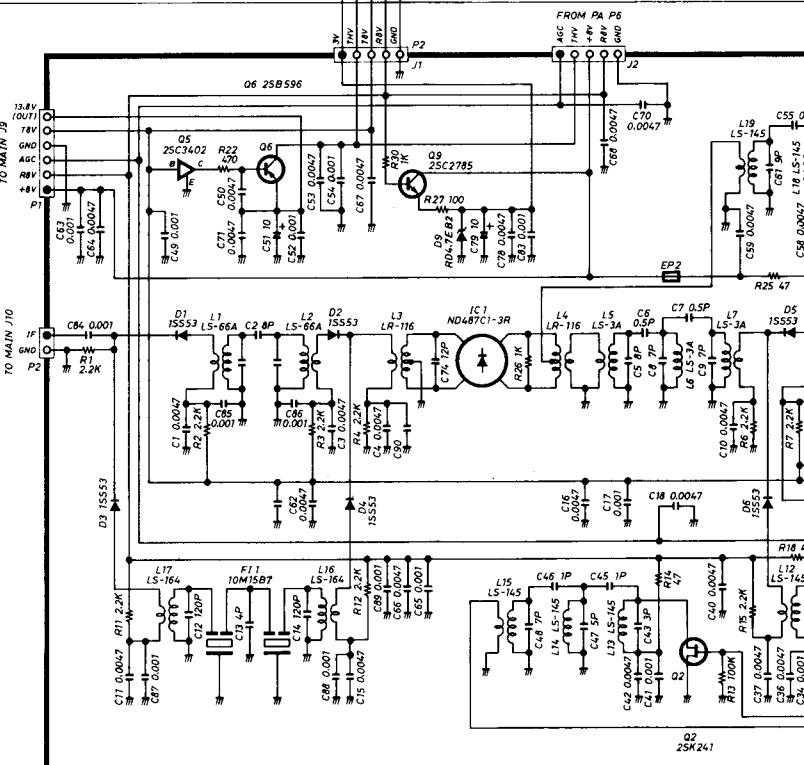
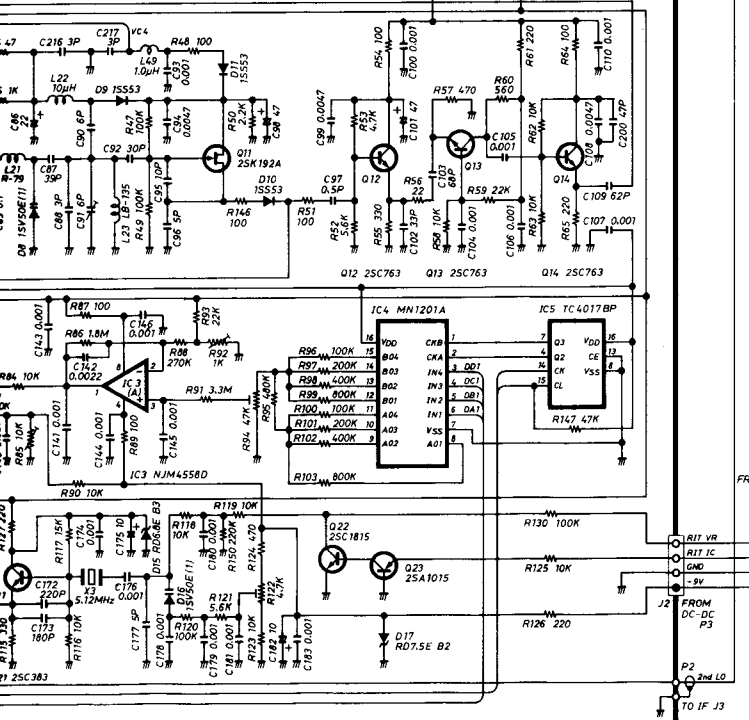
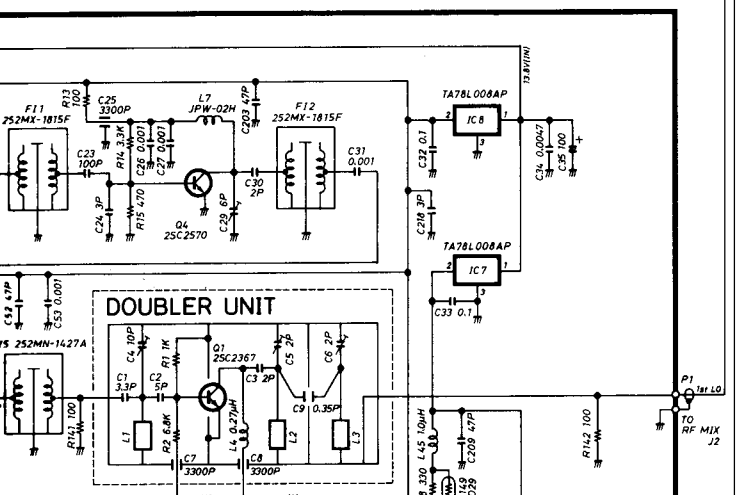
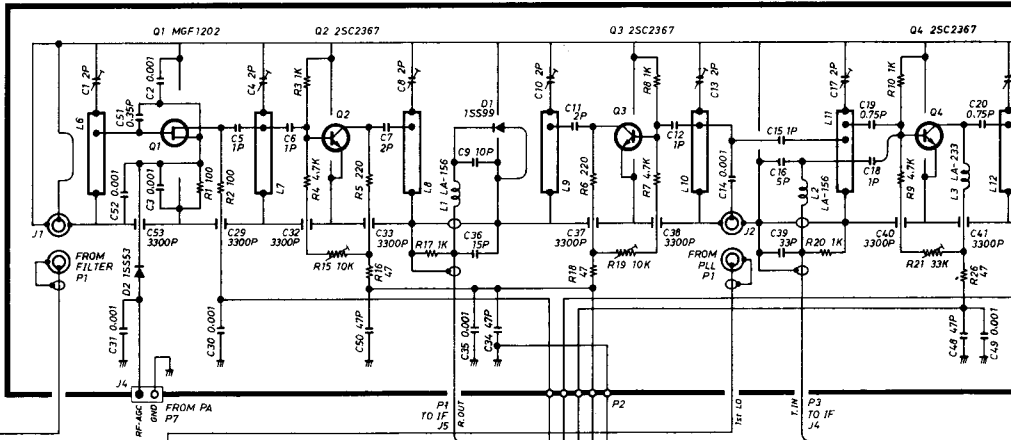
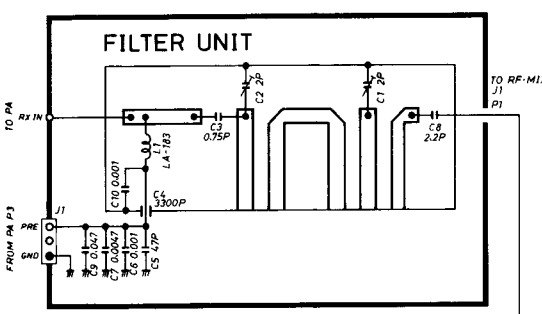

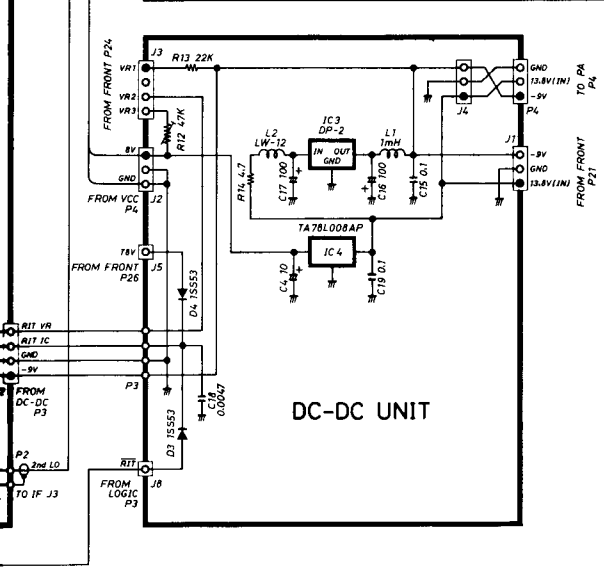
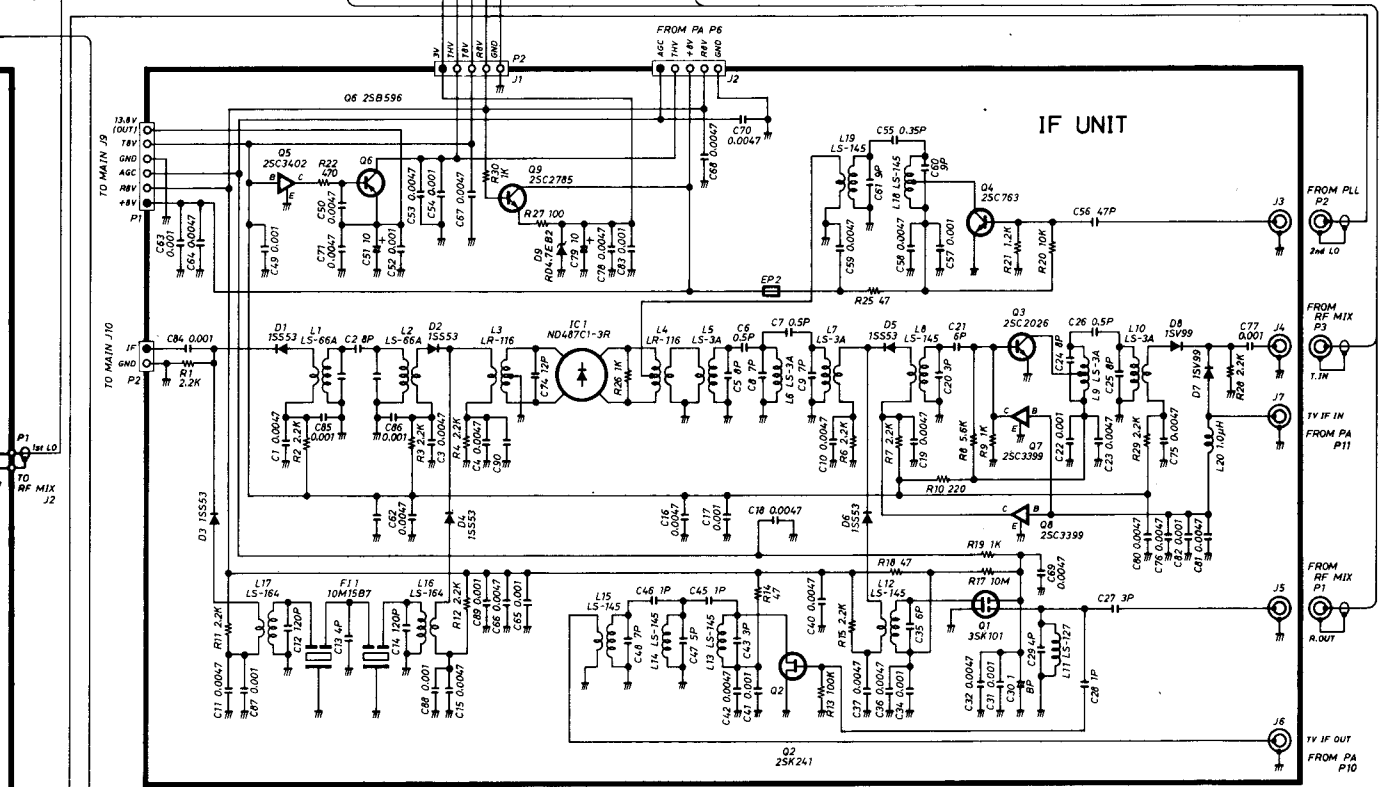
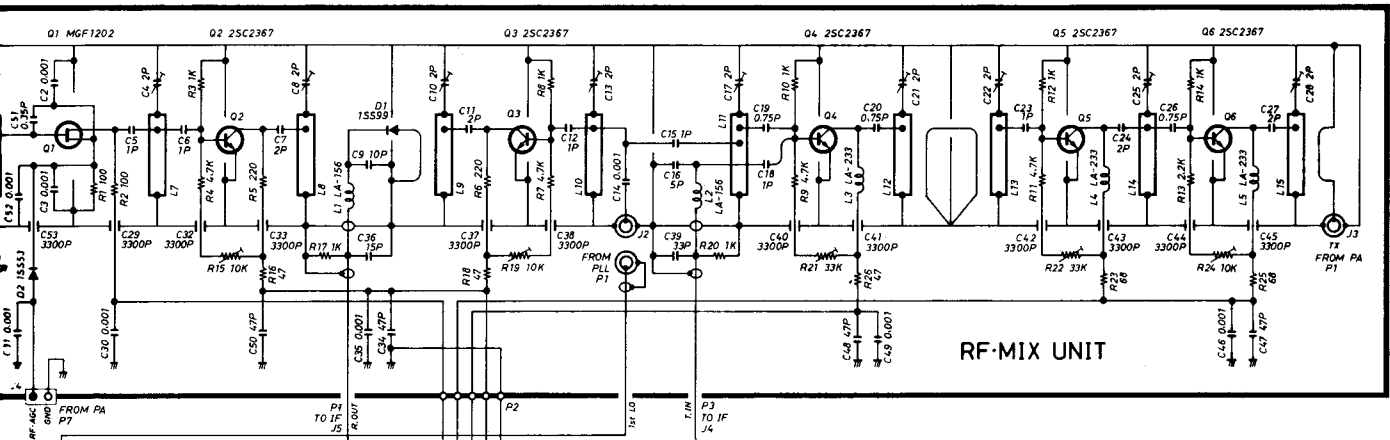

(FRONT ~ PA)
(FRONT ~ INTERFACE)
(FRONT ~ LOGIC)
(FRONT ~ DC-DC)
(DISPLAY ~ LOGIC)
(DISPLAY ~ VCC)

MAIN UNIT

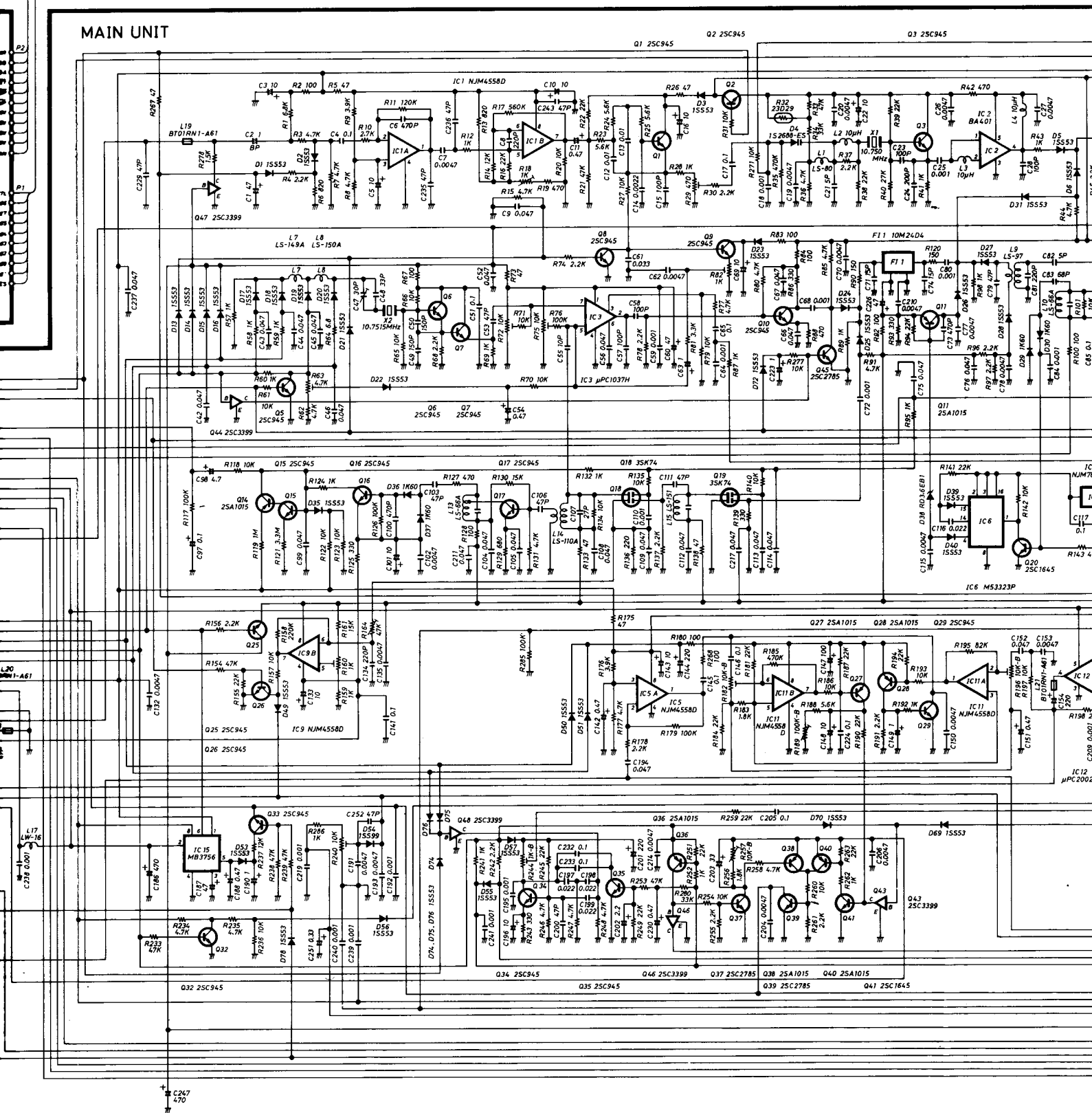

(FRONT ~ LOGIC)
(FRONT ~ TONE SOL)
(FRONT ~ PA)

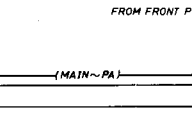
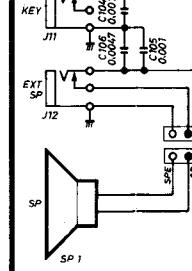
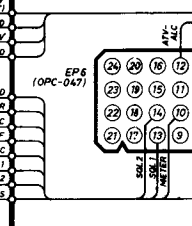
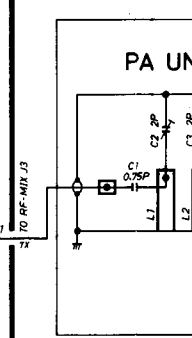
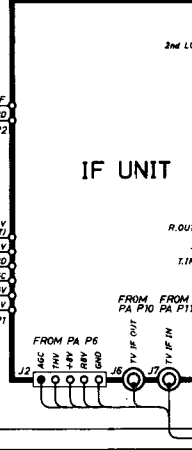
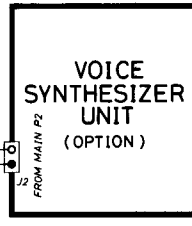
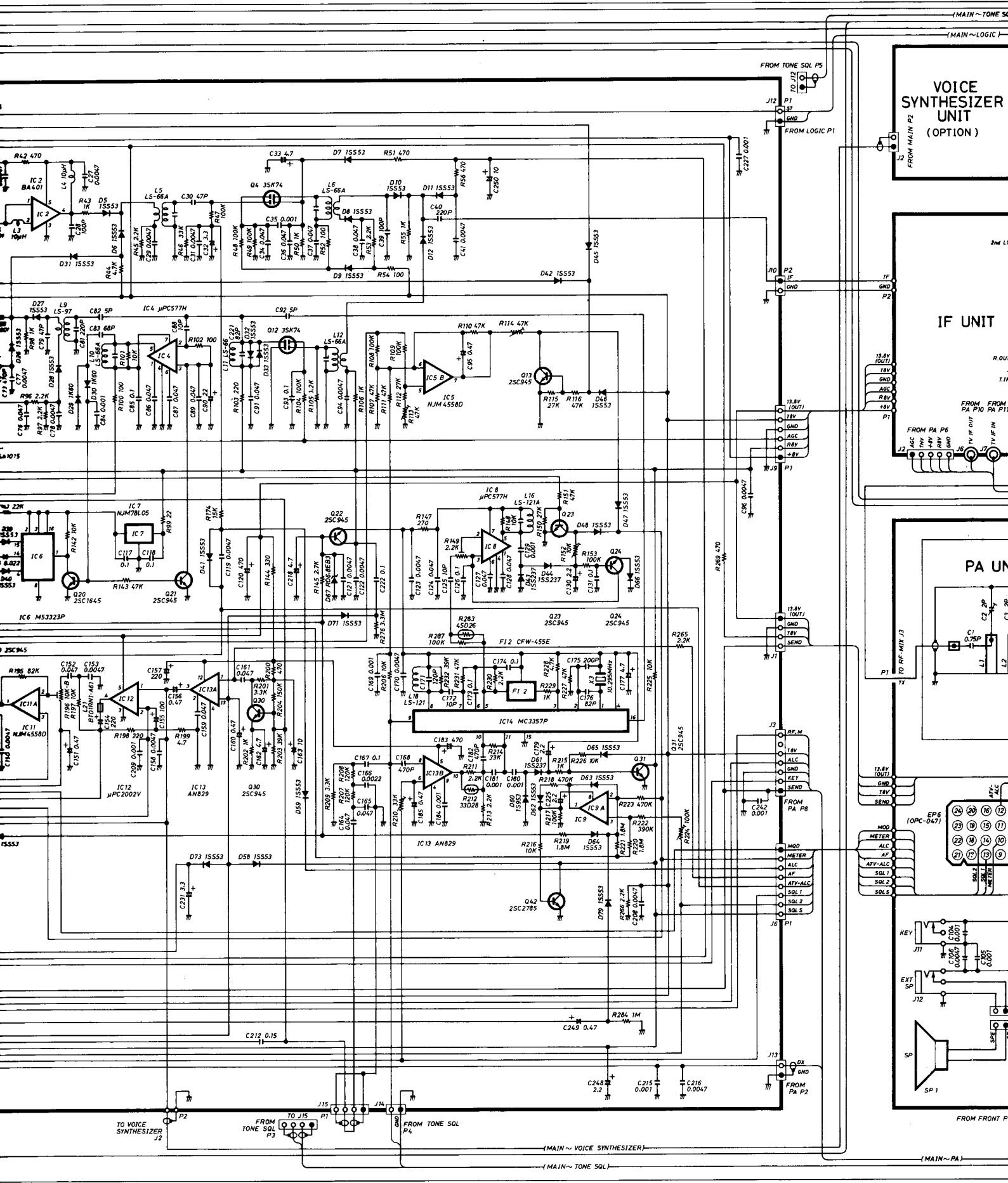

(MAIN ~ VOICE SYNTHESIZER)

(MAIN ~ TONE SQL)

(MAIN ~ PA)

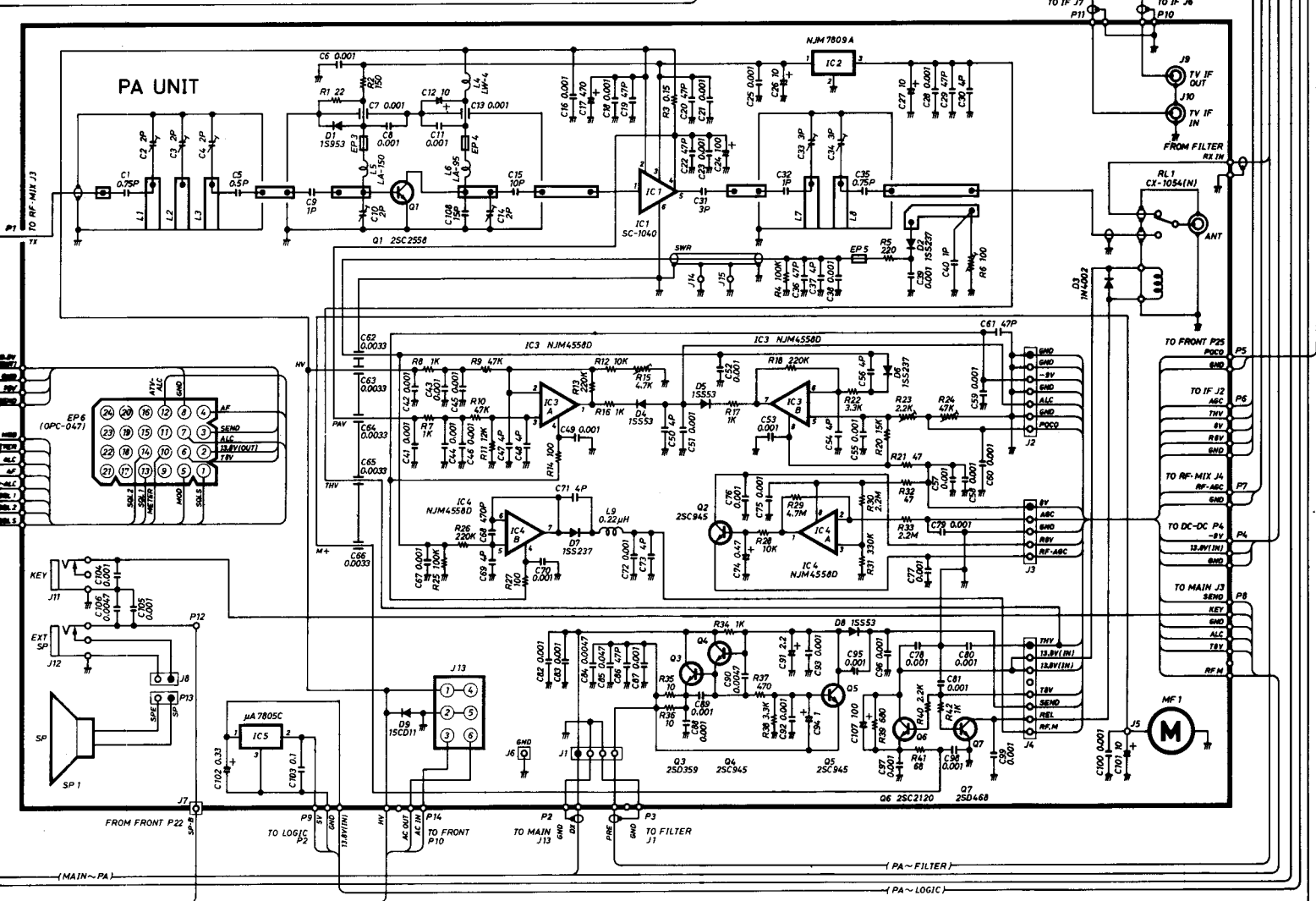
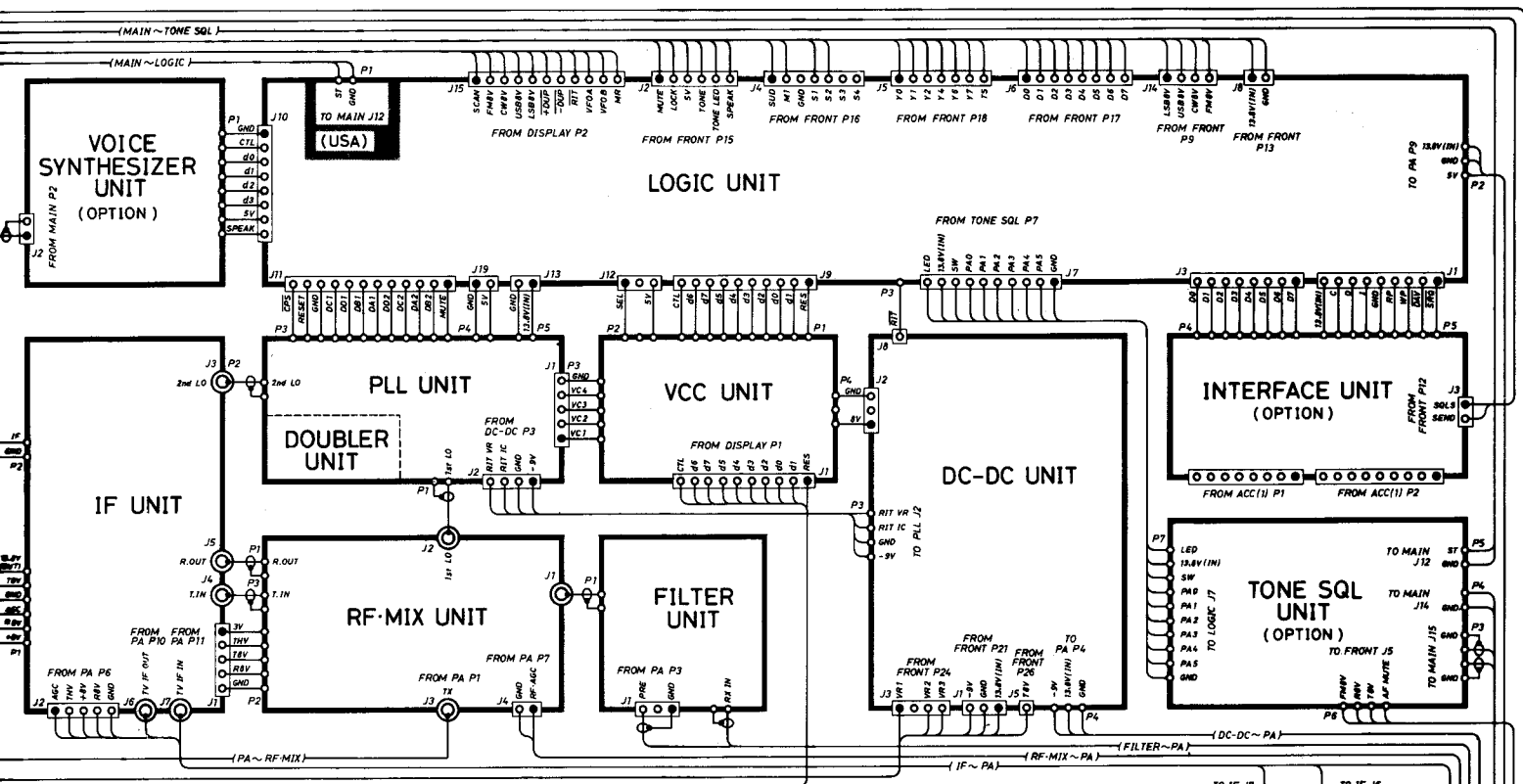

IC-1271E SCHEMATIC DIAGRAM

(DISPLAY~VCC)

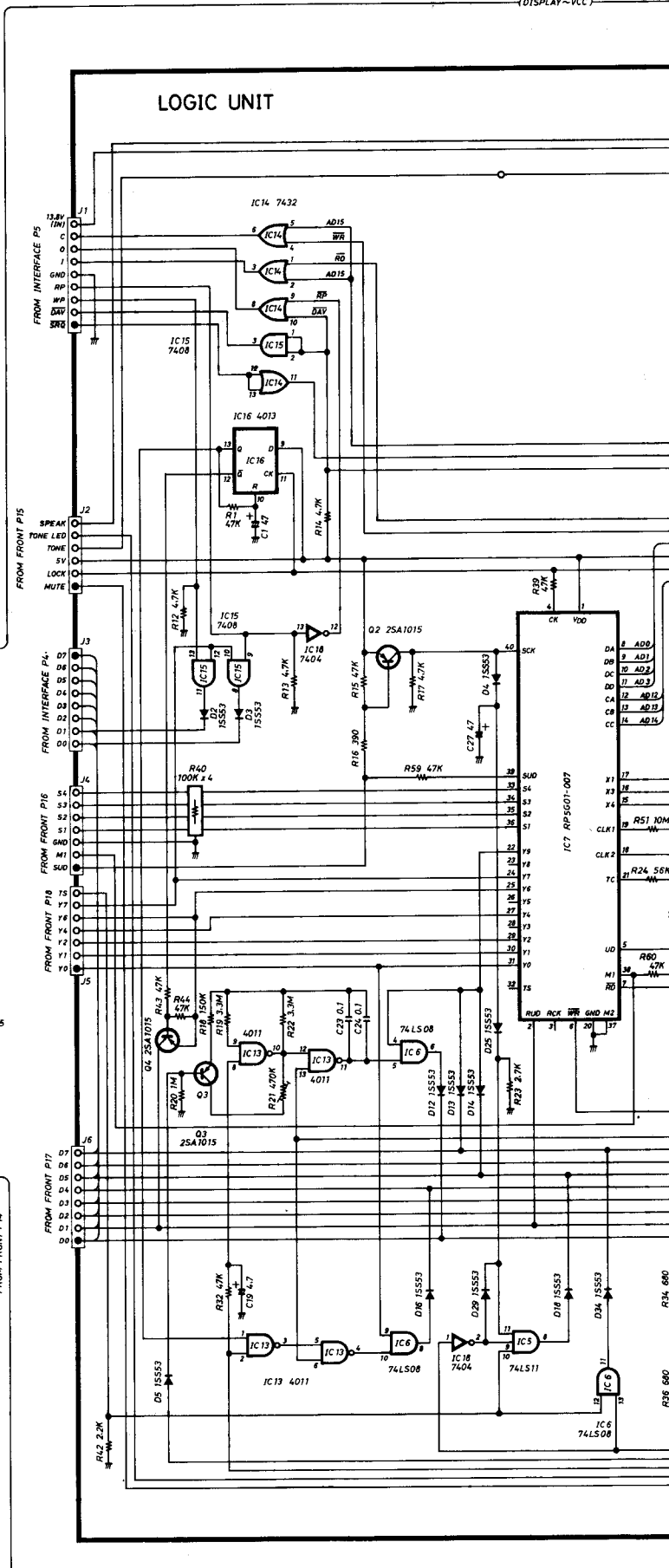
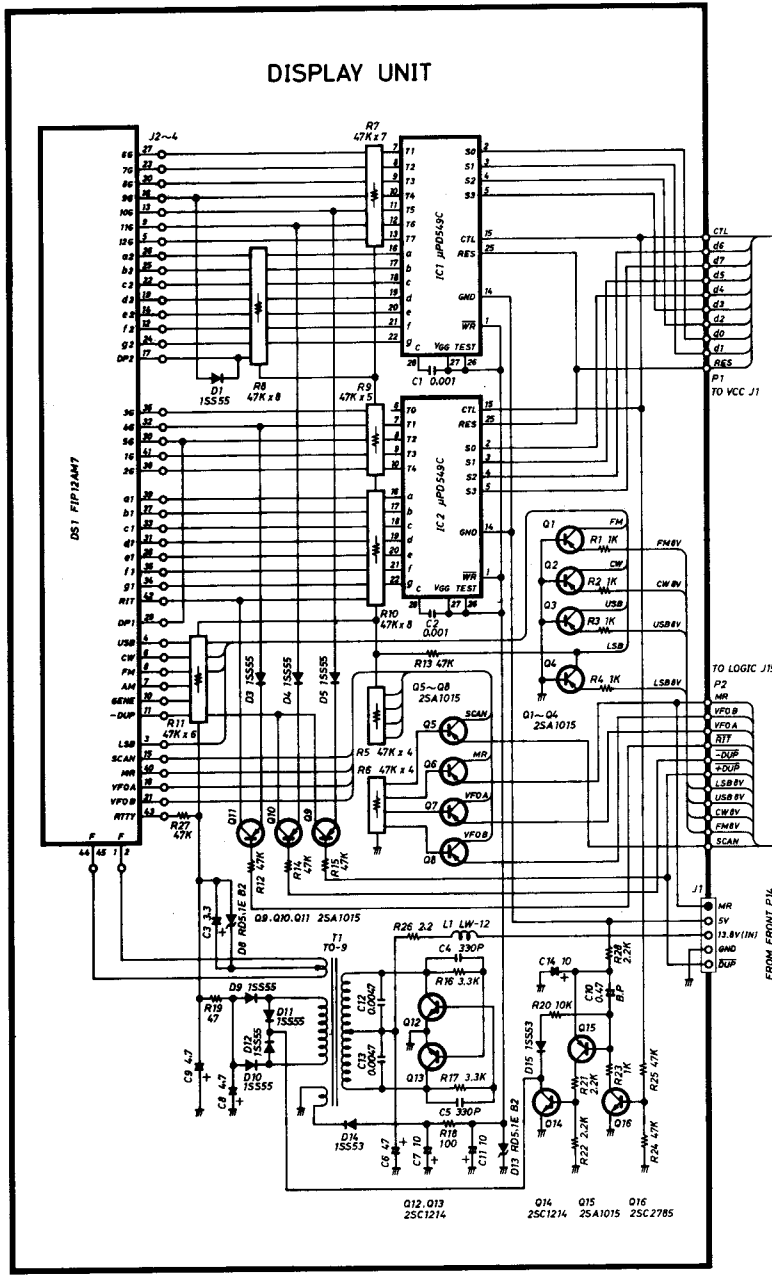

IC DIAGRAM

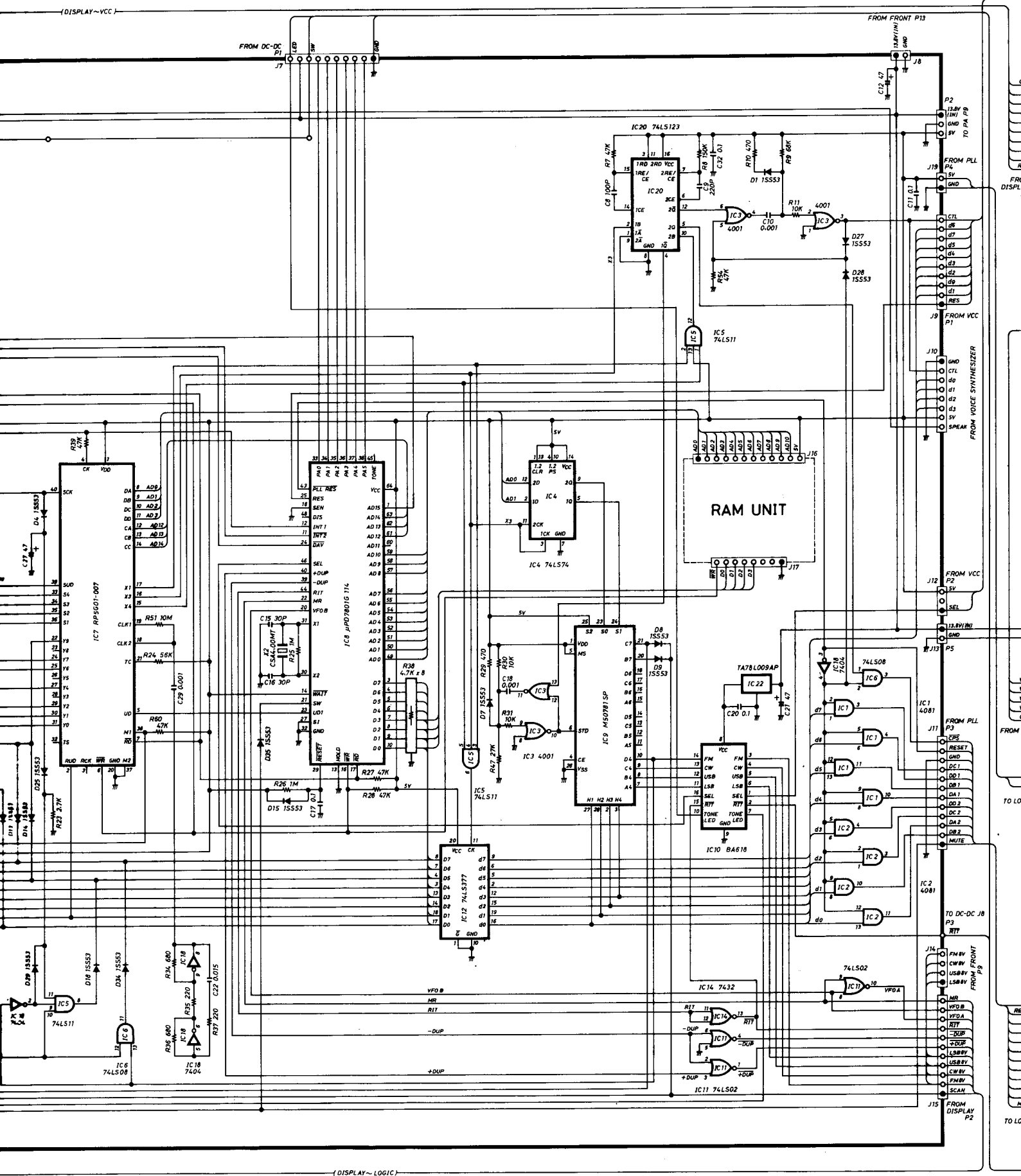

(DISPLAY ~ VCC)

(DISPLAY ~ LOGIC)

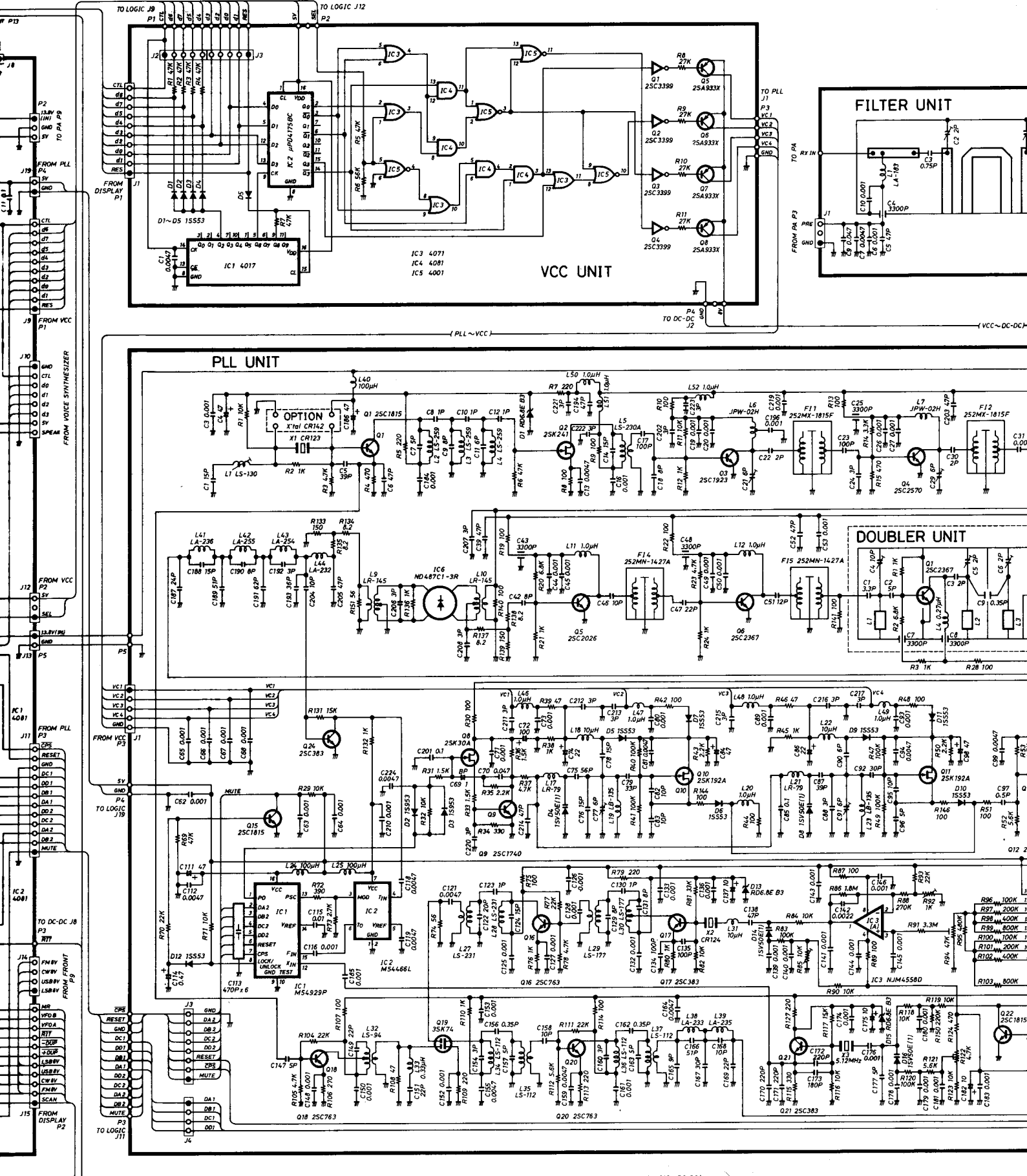

VCC UNIT

PLL UNIT

FILTER UNIT

DOUBLER UNIT

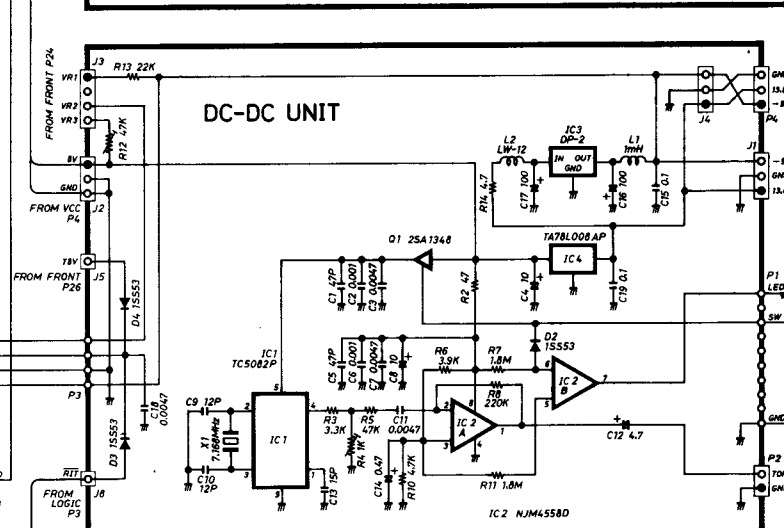
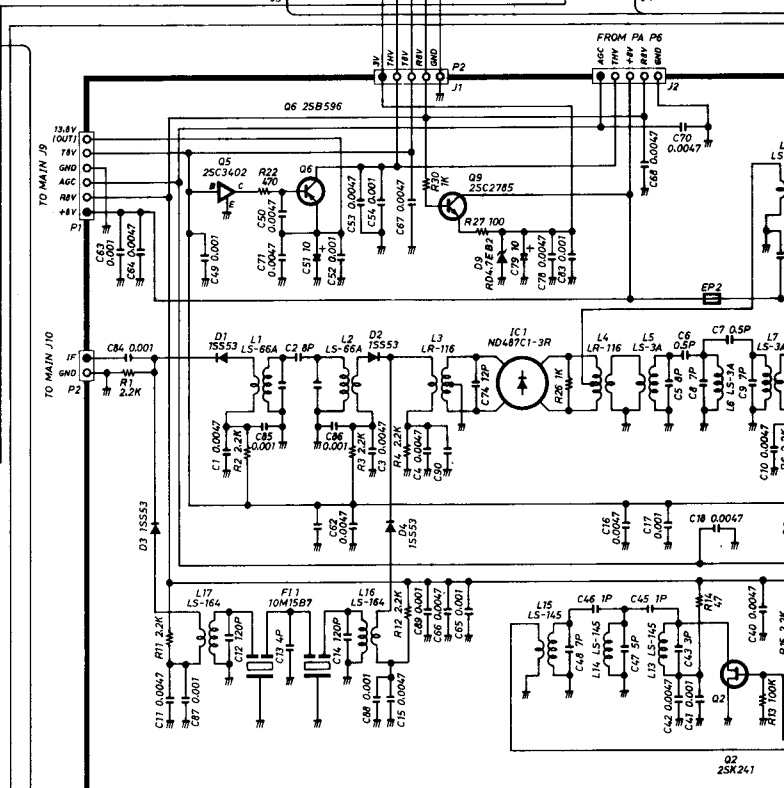
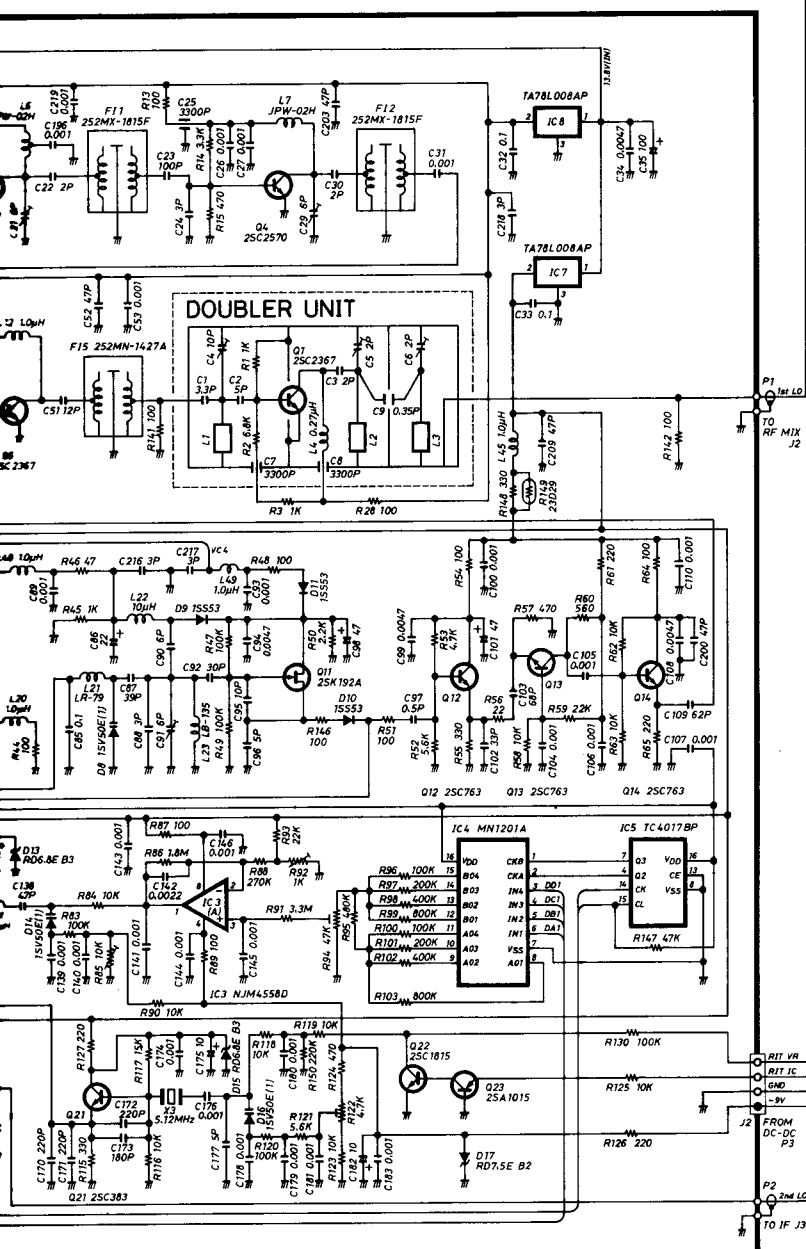
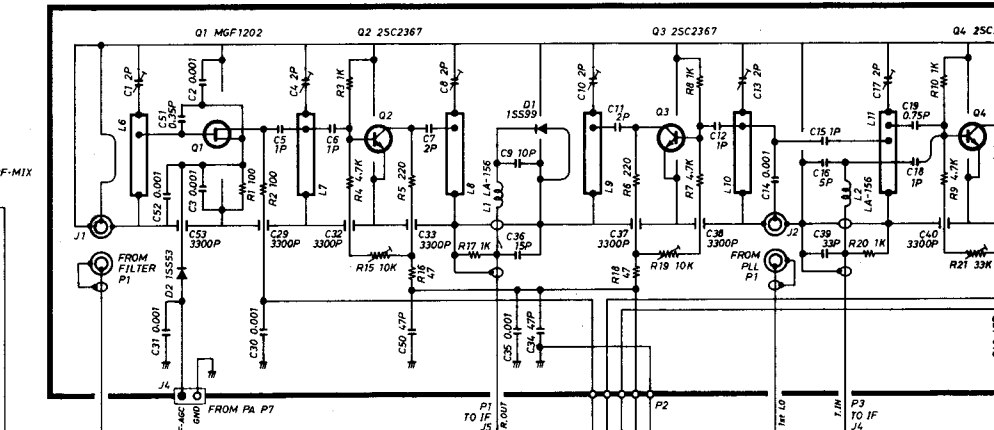
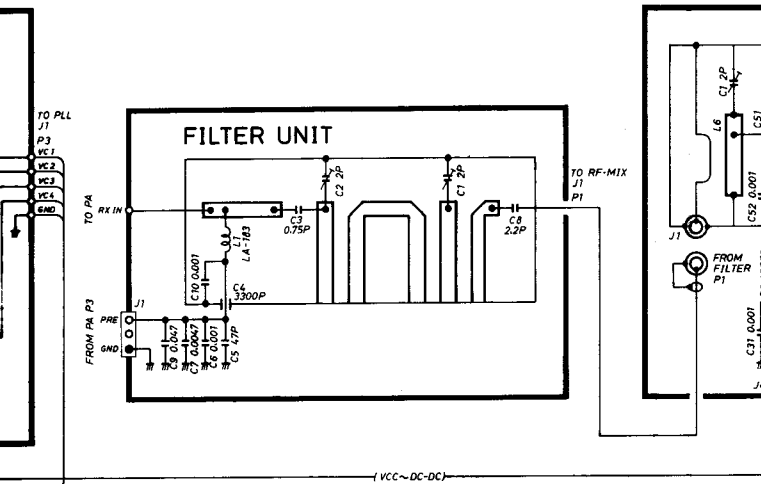

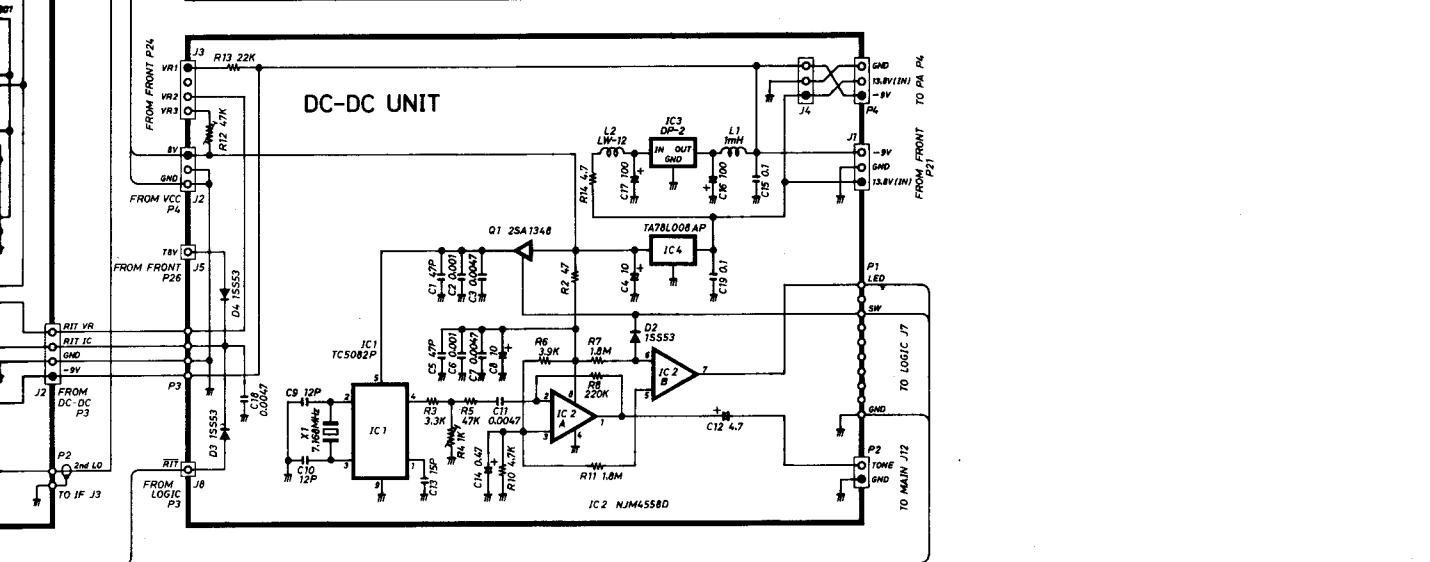
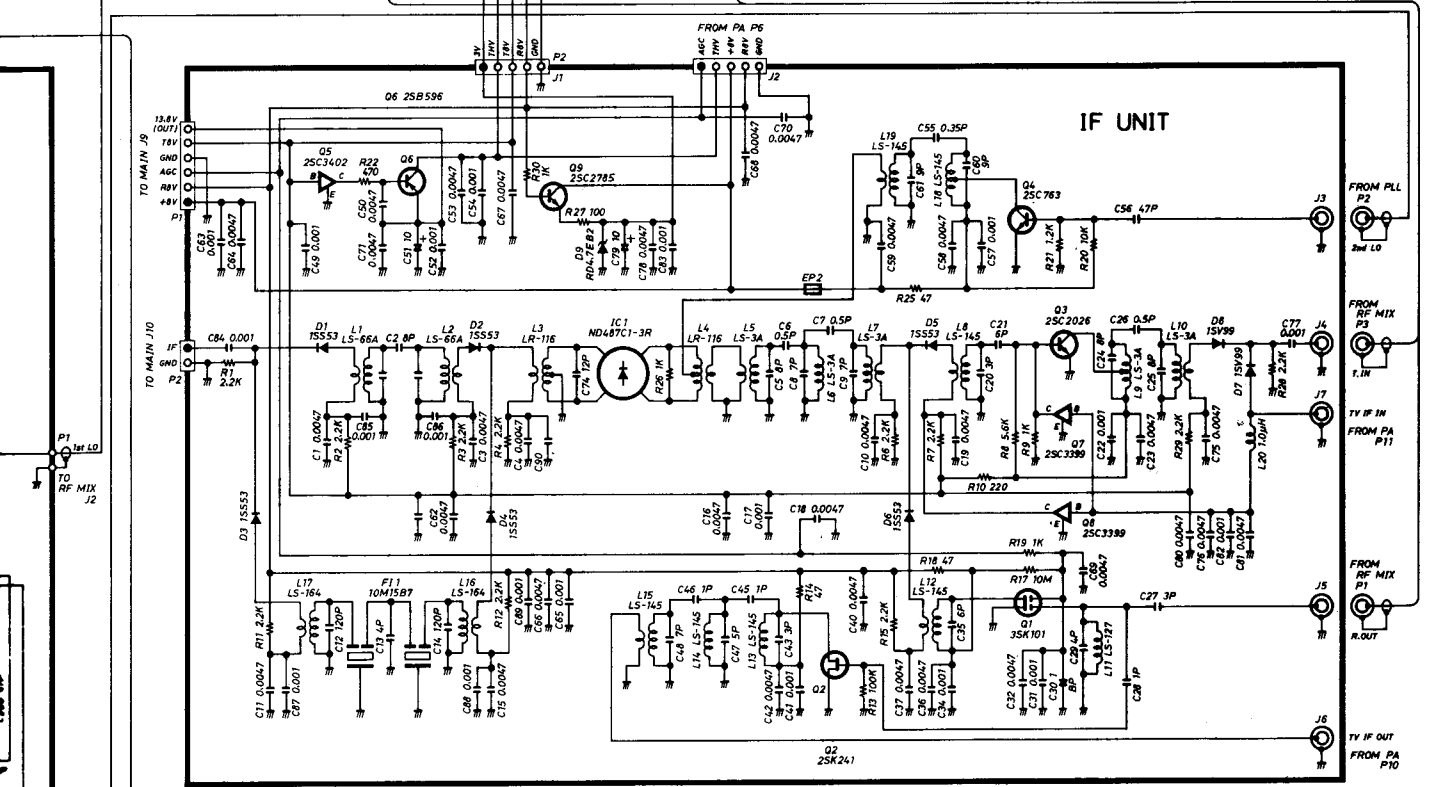
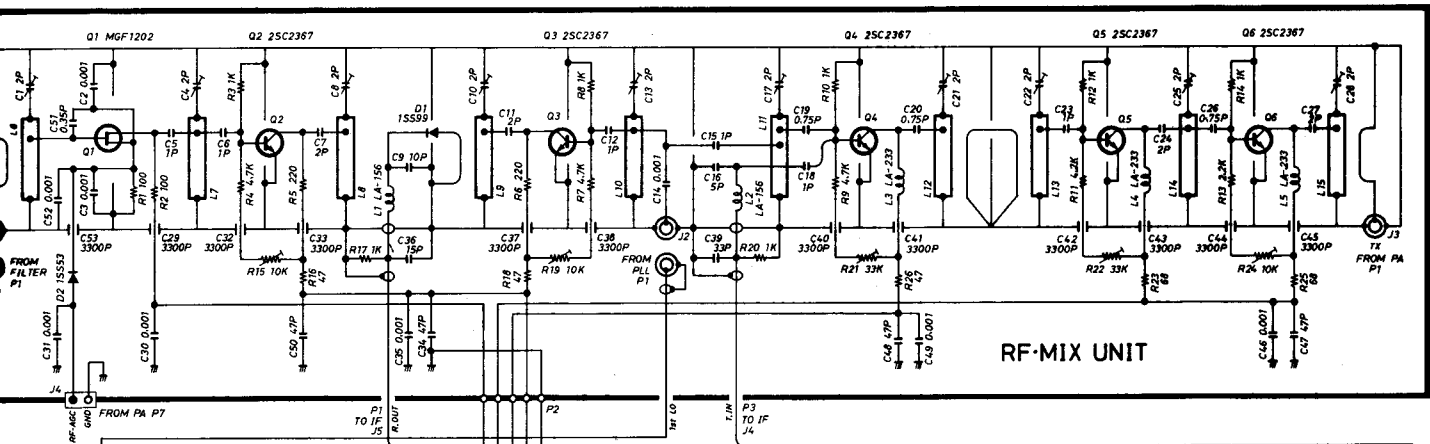

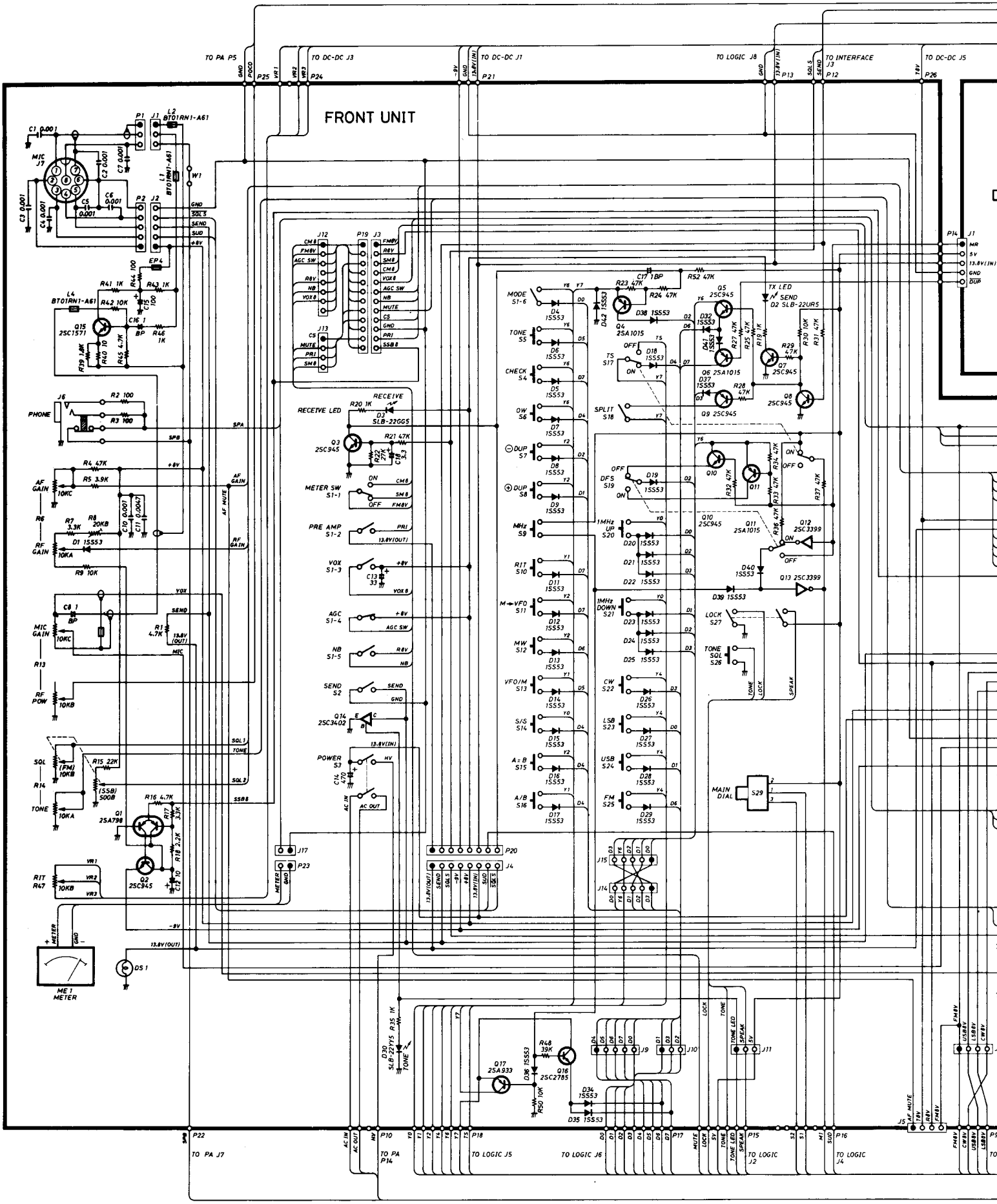

FRONT UNIT

TO PA P5 GND P25 V1 P1
TO DC-DC J3 V2 P24
TO DC-DC J1 GND P21
TO LOGIC J8 GND P13
TO INTERFACE J3 SOL5 SEND P12
TO DC-DC J5 18V P26

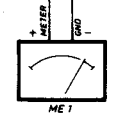
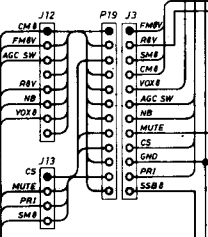

P22 TO PA J7
AC IN
AC OUT
V1
V2
V3
V4
V5
V6
V7
V8
V9
V10
V11
V12
V13
V14
V15
V16
V17
V18
V19
V20
V21
V22
V23
V24
V25
V26
V27
V28
V29
V30
V31
V32
V33
V34
V35
V36
V37
V38
V39
V40
V41
V42
V43
V44
V45
V46
V47
V48
V49
V50
V51
V52
V53
V54
V55
V56
V57
V58
V59
V60
V61
V62
V63
V64
V65
V66
V67
V68
V69
V70
V71
V72
V73
V74
V75
V76
V77
V78
V79
V80
V81
V82
V83
V84
V85
V86
V87
V88
V89
V90
V91
V92
V93
V94
V95
V96
V97
V98
V99
V100
V101
V102
V103
V104
V105
V106
V107
V108
V109
V110
V111
V112
V113
V114
V115
V116
V117
V118
V119
V120
V121
V122
V123
V124
V125
V126
V127
V128
V129
V130
V131
V132
V133
V134
V135
V136
V137
V138
V139
V140
V141
V142
V143
V144
V145
V146
V147
V148
V149
V150
V151
V152
V153
V154
V155
V156
V157
V158
V159
V160
V161
V162
V163
V164
V165
V166
V167
V168
V169
V170
V171
V172
V173
V174
V175
V176
V177
V178
V179
V180
V181
V182
V183
V184
V185
V186
V187
V188
V189
V190
V191
V192
V193
V194
V195
V196
V197
V198
V199
V200
V201
V202
V203
V204
V205
V206
V207
V208
V209
V210
V211
V212
V213
V214
V215
V216
V217
V218
V219
V220
V221
V222
V223
V224
V225
V226
V227
V228
V229
V230
V231
V232
V233
V234
V235
V236
V237
V238
V239
V240
V241
V242
V243
V244
V245
V246
V247
V248
V249
V250
V251
V252
V253
V254
V255
V256
V257
V258
V259
V260
V261
V262
V263
V264
V265
V266
V267
V268
V269
V270
V271
V272
V273
V274
V275
V276
V277
V278
V279
V280
V281
V282
V283
V284
V285
V286
V287
V288
V289
V290
V291
V292
V293
V294
V295
V296
V297
V298
V299
V300
V301
V302
V303
V304
V305
V306
V307
V308
V309
V310
V311
V312
V313
V314
V315
V316
V317
V318
V319
V320
V321
V322
V323
V324
V325
V326
V327
V328
V329
V330
V331
V332
V333
V334
V335
V336
V337
V338
V339
V340
V341
V342
V343
V344
V345
V346
V347
V348
V349
V350
V351
V352
V353
V354
V355
V356
V357
V358
V359
V360
V361
V362
V363
V364
V365
V366
V367
V368
V369
V370
V371
V372
V373
V374
V375
V376
V377
V378
V379
V380
V381
V382
V383
V384
V385
V386
V387
V388
V389
V390
V391
V392
V393
V394
V395
V396
V397
V398
V399
V400
V401
V402
V403
V404
V405
V406
V407
V408
V409
V410
V411
V412
V413
V414
V415
V416
V417
V418
V419
V420
V421
V422
V423
V424
V425
V426
V427
V428
V429
V430
V431
V432
V433
V434
V435
V436
V437
V438
V439
V440
V441
V442
V443
V444
V445
V446
V447
V448
V449
V450
V451
V452
V453
V454
V455
V456
V457
V458
V459
V460
V461
V462
V463
V464
V465
V466
V467
V468
V469
V470
V471
V472
V473
V474
V475
V476
V477
V478
V479
V480
V481
V482
V483
V484
V485
V486
V487
V488
V489
V490
V491
V492
V493
V494
V495
V496
V497
V498
V499
V500
V501
V502
V503
V504
V505
V506
V507
V508
V509
V510
V511
V512
V513
V514
V515
V516
V517
V518
V519
V520
V521
V522
V523
V524
V525
V526
V527
V528
V529
V530
V531
V532
V533
V534
V535
V536
V537
V538
V539
V540
V541
V542
V543
V544
V545
V546
V547
V548
V549
V550
V551
V552
V553
V554
V555
V556
V557
V558
V559
V560
V561
V562
V563
V564
V565
V566
V567
V568
V569
V570
V571
V572
V573
V574
V575
V576
V577
V578
V579
V580
V581
V582
V583
V584
V585
V586
V587
V588
V589
V590
V591
V592
V593
V594
V595
V596
V597
V598
V599
V600
V601
V602
V603
V604
V605
V606
V607
V608
V609
V610
V611
V612
V613
V614
V615
V616
V617
V618
V619
V620
V621
V622
V623
V624
V625
V626
V627
V628
V629
V630
V631
V632
V633
V634
V635
V636
V637
V638
V639
V640
V641
V642
V643
V644
V645
V646
V647
V648
V649
V650
V651
V652
V653
V654
V655
V656
V657
V658
V659
V660
V661
V662
V663
V664
V665
V666
V667
V668
V669
V670
V671
V672
V673
V674
V675
V676
V677
V678
V679
V680
V681
V682
V683
V684
V685
V686
V687
V688
V689
V690
V691
V692
V693
V694
V695
V696
V697
V698
V699
V700
V701
V702
V703
V704
V705
V706
V707
V708
V709
V710
V711
V712
V713
V714
V715
V716
V717
V718
V719
V720
V721
V722
V723
V724
V725
V726
V727
V728
V729
V730
V731
V732
V733
V734
V735
V736
V737
V738
V739
V740
V741
V742
V743
V744
V745
V746
V747
V748
V749
V750
V751
V752
V753
V754
V755
V756
V757
V758
V759
V760
V761
V762
V763
V764
V765
V766
V767
V768
V769
V770
V771
V772
V773
V774
V775
V776
V777
V778
V779
V780
V781
V782
V783
V784
V785
V786
V787
V788
V789
V790
V791
V792
V793
V794
V795
V796
V797
V798
V799
V800
V801
V802
V803
V804
V805
V806
V807
V808
V809
V810
V811
V812
V813
V814
V815
V816
V817
V818
V819
V820
V821
V822
V823
V824
V825
V826
V827
V828
V829
V830
V831
V832
V833
V834
V835
V836
V837
V838
V839
V840
V841
V842
V843
V844
V845
V846
V847
V848
V849
V850
V851
V852
V853
V854
V855
V856
V857
V858
V859
V860
V861
V862
V863
V864
V865
V866
V867
V868
V869
V870
V871
V872
V873
V874
V875
V876
V877
V878
V879
V880
V881
V882
V883
V884
V885
V886
V887
V888
V889
V890
V891
V892
V893
V894
V895
V896
V897
V898
V899
V900
V901
V902
V903
V904
V905
V906
V907
V908
V909
V910
V911
V912
V913
V914
V915
V916
V917
V918
V919
V920
V921
V922
V923
V924
V925
V926
V927
V928
V929
V930
V931
V932
V933
V934
V935
V936
V937
V938
V939
V940
V941
V942
V943
V944
V945
V946
V947
V948
V949
V950
V951
V952
V953
V954
V955
V956
V957
V958
V959
V960
V961
V962
V963
V964
V965
V966
V967
V968
V969
V970
V971
V972
V973
V974
V975
V976
V977
V978
V979
V980
V981
V982
V983
V984
V985
V986
V987
V988
V989
V990
V991
V992
V993
V994
V995
V996
V997
V998
V999
V1000

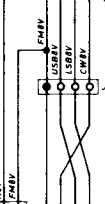
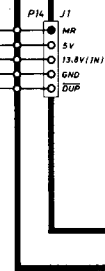

DISPLAY UNIT

MAIN UNIT

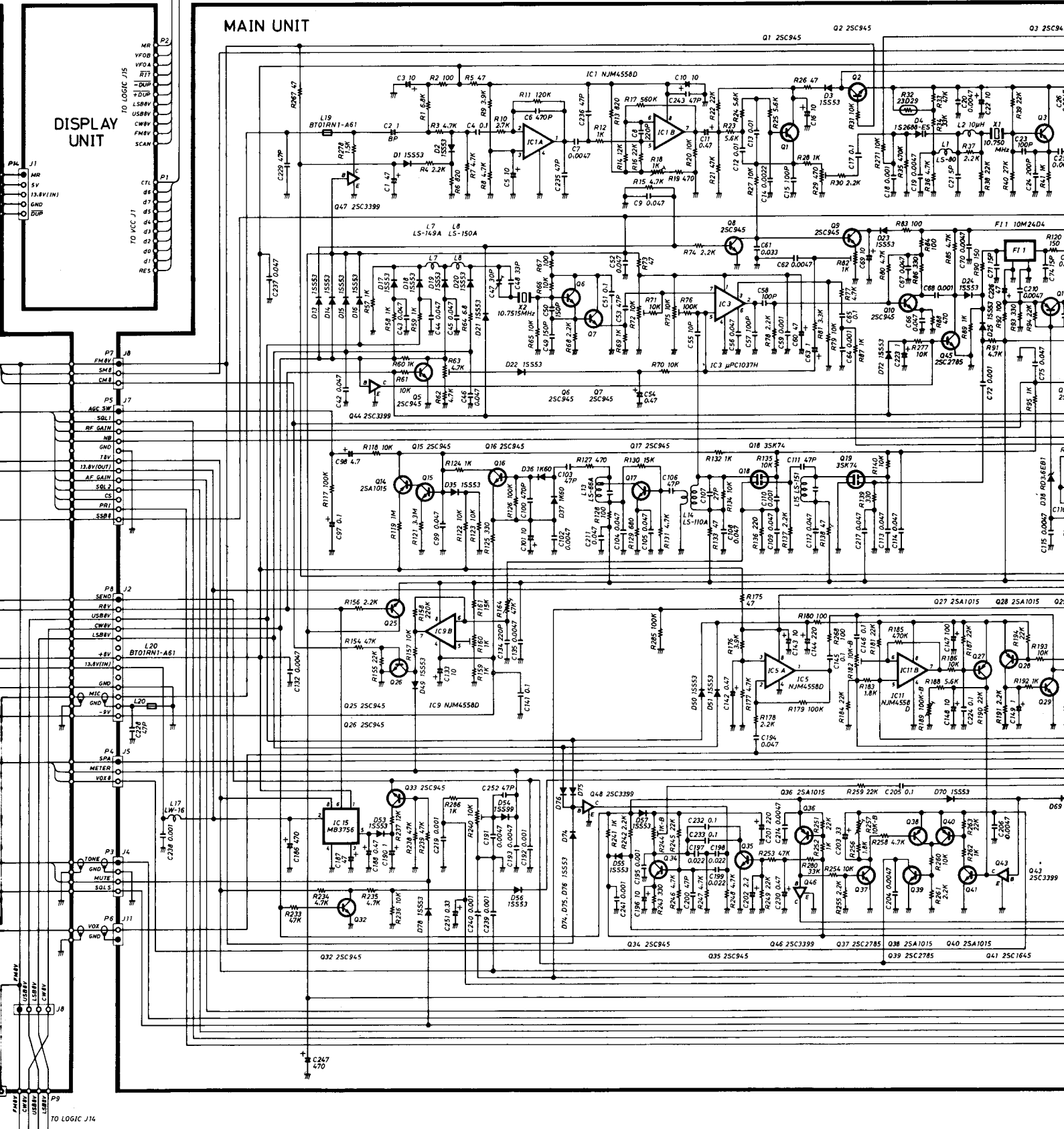

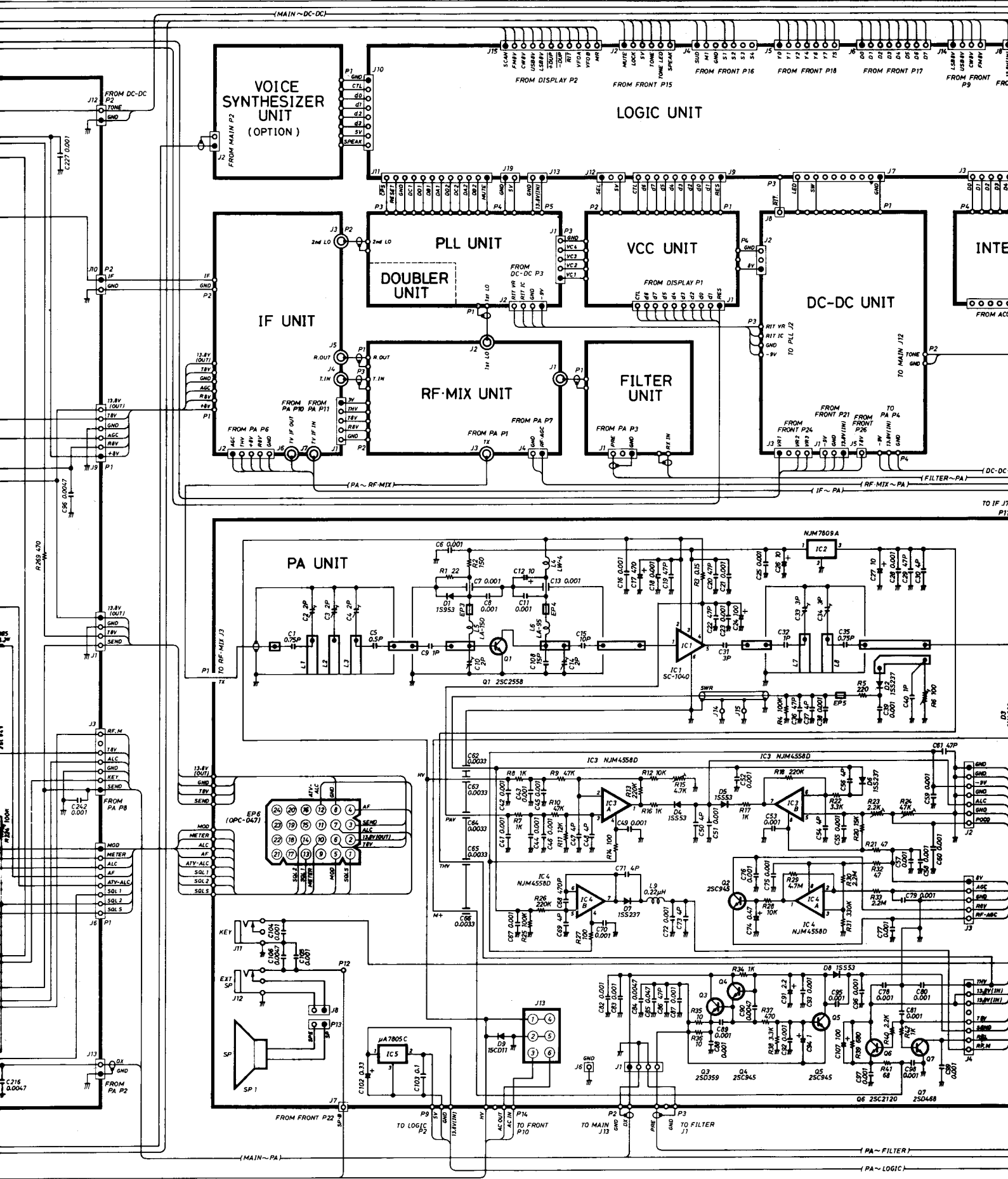

1200MHz ATV ADAPTER

TV-1200

SERVICE MANUAL

ASSISTANCE

Three separate versions of the **TV-1200** have been designed for use in the U.S.A., Europe, and Australia. This service manual covers every version. When using the manual each model can be referred to by the following assigned version numbers:

- #02 U.S.A. version
- #03 AUSTRALIA version
- #04 EUROPE version

If you require assistance or information regarding the operation and capabilities of the **TV-1200**, please contact your nearest authorized ICOM Dealer or ICOM Service Center.

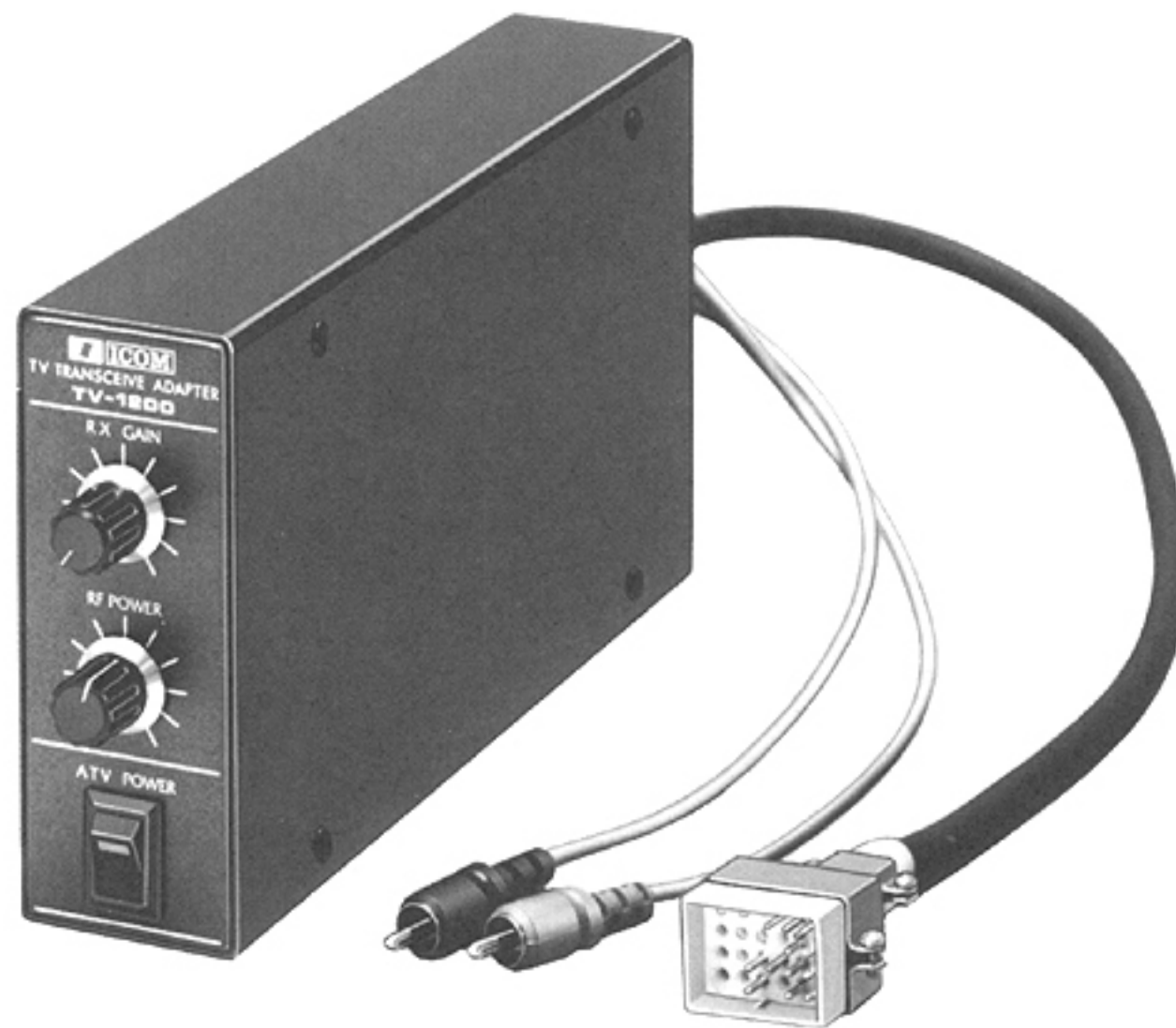

TABLE OF CONTENTS

SECTION 1	SPECIFICATIONS	1 - 1
SECTION 2	OUTSIDE VIEWS	2 - 1
SECTION 3	BLOCK DIAGRAM	3 - 1
SECTION 4	MAINTENANCE AND ADJUSTMENT	4 - 1 ~ 2
SECTION 5	CIRCUIT DESCRIPTION	5 - 1
SECTION 6	VOLTAGE/CIRCUIT DIAGRAMS	6 - 1 ~ 2
SECTION 7	BOARD LAYOUT	7 - 1
SECTION 8	IC SPECIFICATIONS	8 - 1 ~ 2
SECTION 9	PARTS LIST	9 - 1 ~ 4
SECTION 10	SCHEMATIC DIAGRAM	SEPARATE

GENERAL

- Type of emission : A5, A9
- Modulation system : Low level modulation
- Power supply requirement : 13.8V DC±15%
- Current drain (at 13.8V DC) : Receiving 155mA
Transmitting 210mA
- Dimensions : 205(244)mm(W)×110(110)mm(H)×42(46.5)mm(D)
Bracked values include projections.
- Weight : 0.855 kg

TRANSMITTER CIRCUIT

- RF output power (with IC-1271A/E) : Continuously adjustable output power from 1 to 10 watts.
- Video signal input level : More than 500mV
- Audio signal input level : 2mV~1V rms
- Maximum video frequency : 4.5 MHz
- Max. audio modulation frequency : 7.5 kHz
- Max. audio frequency deviation : (±25kHz) #02, (±50 kHz) #03, 04
- Audio carrier frequency stability : (4.5MHz±5kHz) #02, (5.5MHz±5kHz) #03, 04
- Output bandwidth : (9MHz) #02, (11 MHz) #03, 04
- Spurious emissions : More than 50dB below peak power output.
- Monitor output frequency : (Channel 3 61.25MHz) #02, (Channel 1 57.25MHz) #03,
(Channel 4 67.25MHz) #02, (Channel 2 64.25MHz) #03,
(Channel 3 55.25MHz) #04
(Channel 4 62.25MHz) #04
- Monitor output level : -50dBm

RECEIVER CIRCUIT

- Receiver output frequency : (Channel 3 61.25MHz) #02, (Channel 1 57.25MHz) #03,
(Channel 4 67.25MHz) #02, (Channel 2 64.25MHz) #03,
(Channel 3 55.25MHz) #04
(Channel 4 62.25MHz) #04
- Conversion gain : +5~+10 dB
- Transmitter/receiver monitor frequency stability : (±300kHz at channels 3 and 4) #02, #04
(±300kHz at channels 1 and 2) #03

SECTION 2 OUTSIDE VIEWS

TV-1200

FRONT PANEL

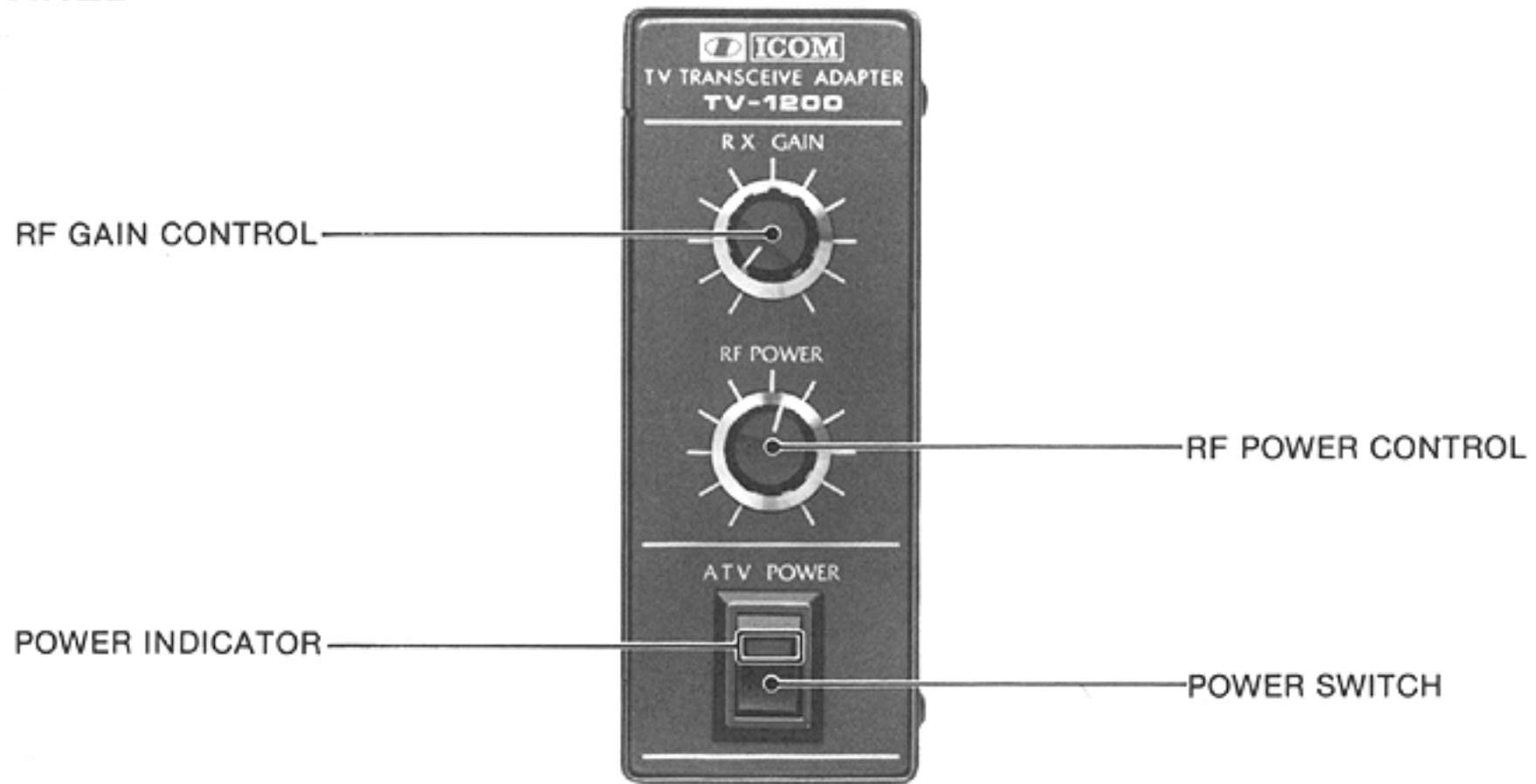

REAR PANEL

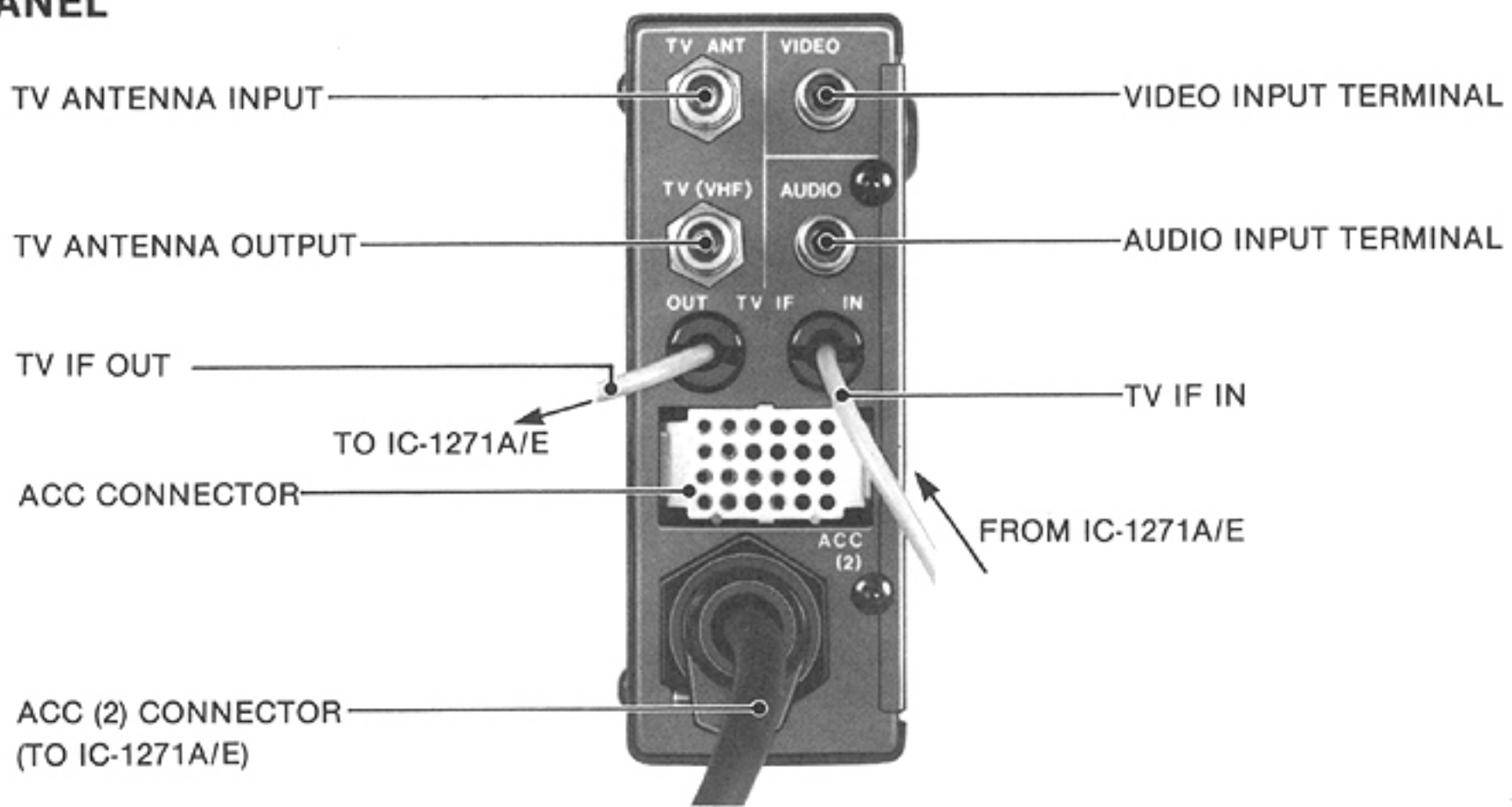

TV-1200 and IC-1271A/E INTERCONNECTIONS

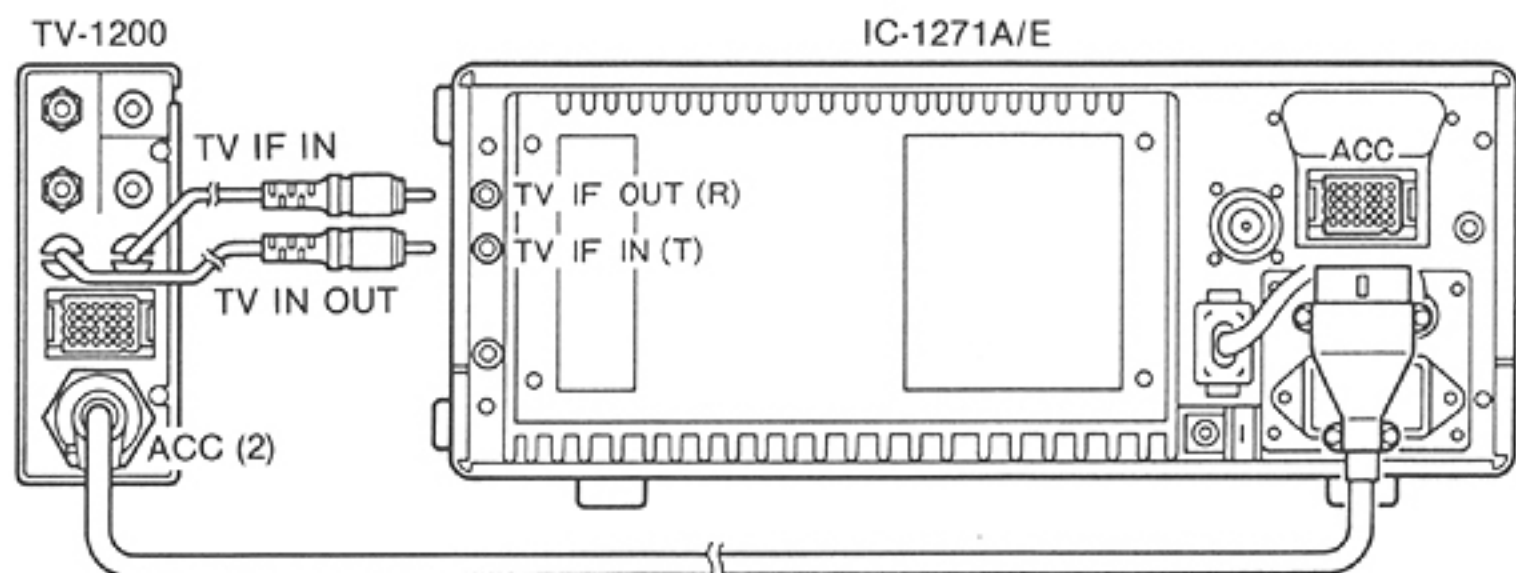

SECTION 3 BLOCK DIAGRAM

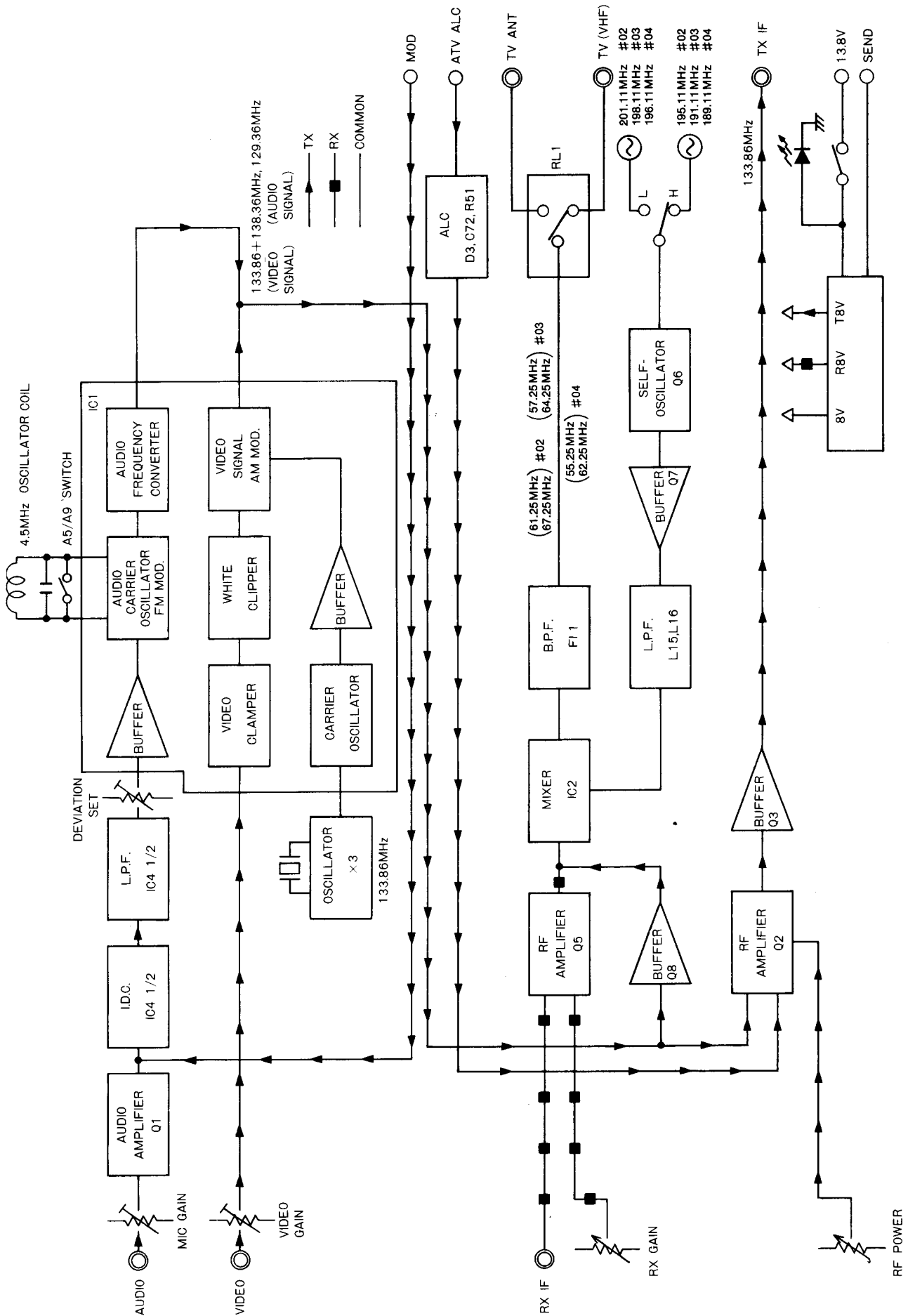

SECTION 4 MAINTENANCE AND ADJUSTMENT

TV-1200

RECEIVER ADJUSTMENT

INSTRUMENTS REQUIRED			CONNECTION			
(1) VOLTAGE REGULATED POWER SUPPLY OUTPUT VOLTAGE : 13.8V DC CURRENT CAPACITY : MORE THAN 8A (2) RF VOLTMETER FREQUENCY RANGE : 0.1~1300MHz MEASURING RANGE : 0.001~10V (3) SIGNAL GENERATOR (SSG) FREQUENCY RANGE : 0.1~1300MHz OUTPUT LEVEL : 0.1 μ V~32mV (-127dBm~-17dBm)						
ADJUSTMENT	ADJUSTMENT CONDITION	UNIT	MEASUREMENT LOCATION	VALUE	UNIT	ADJUST
RECEIVER GAIN	1	ATV	Connect an RF voltmeter to W6.	OUTPUT MAX	ATV	L10, L11
	2.			Less than 3dB	—	Verify
NOTE: If measured Value is not less than 3dB repeat adjustment.						

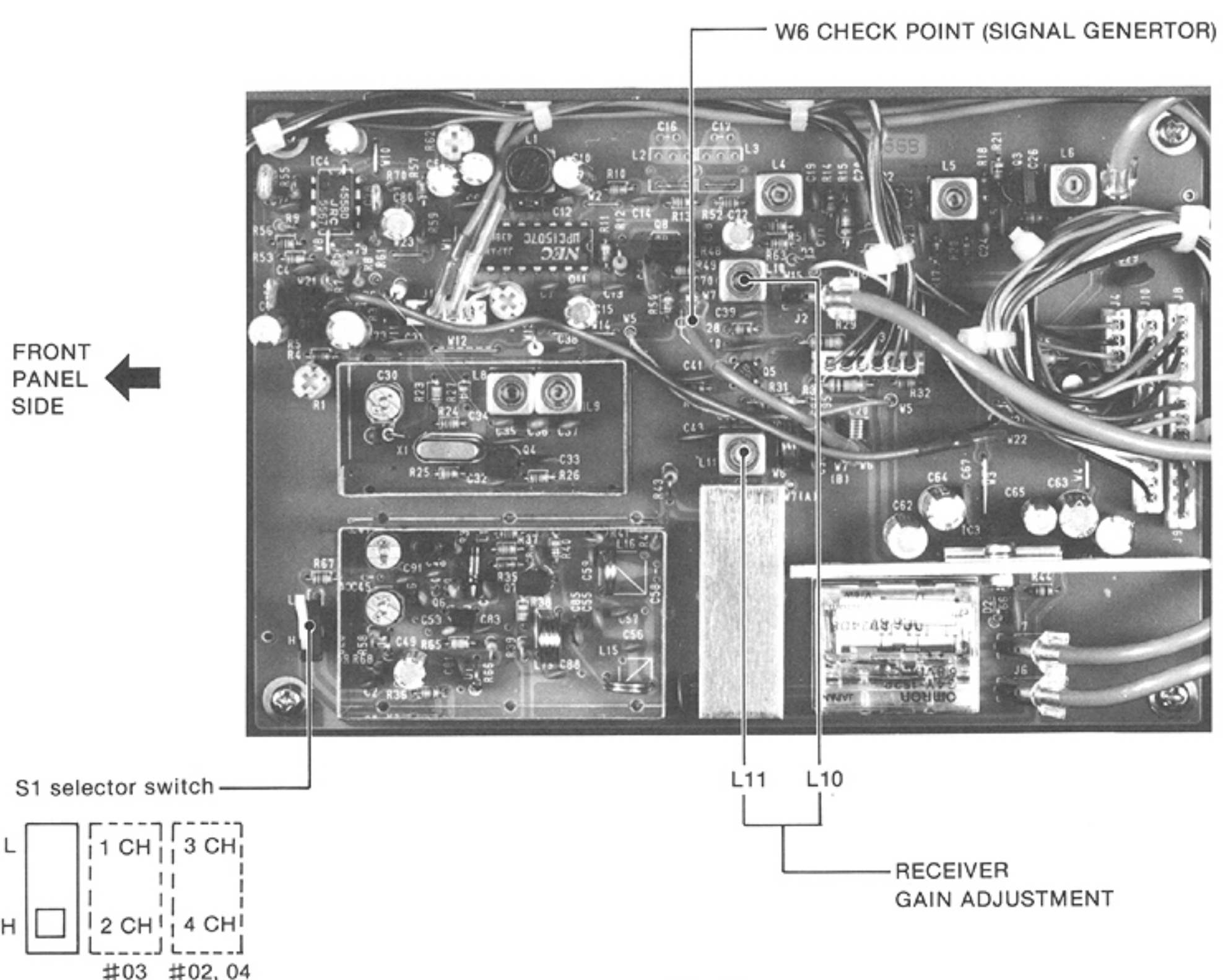

TRANSMITTER ADJUSTMENT

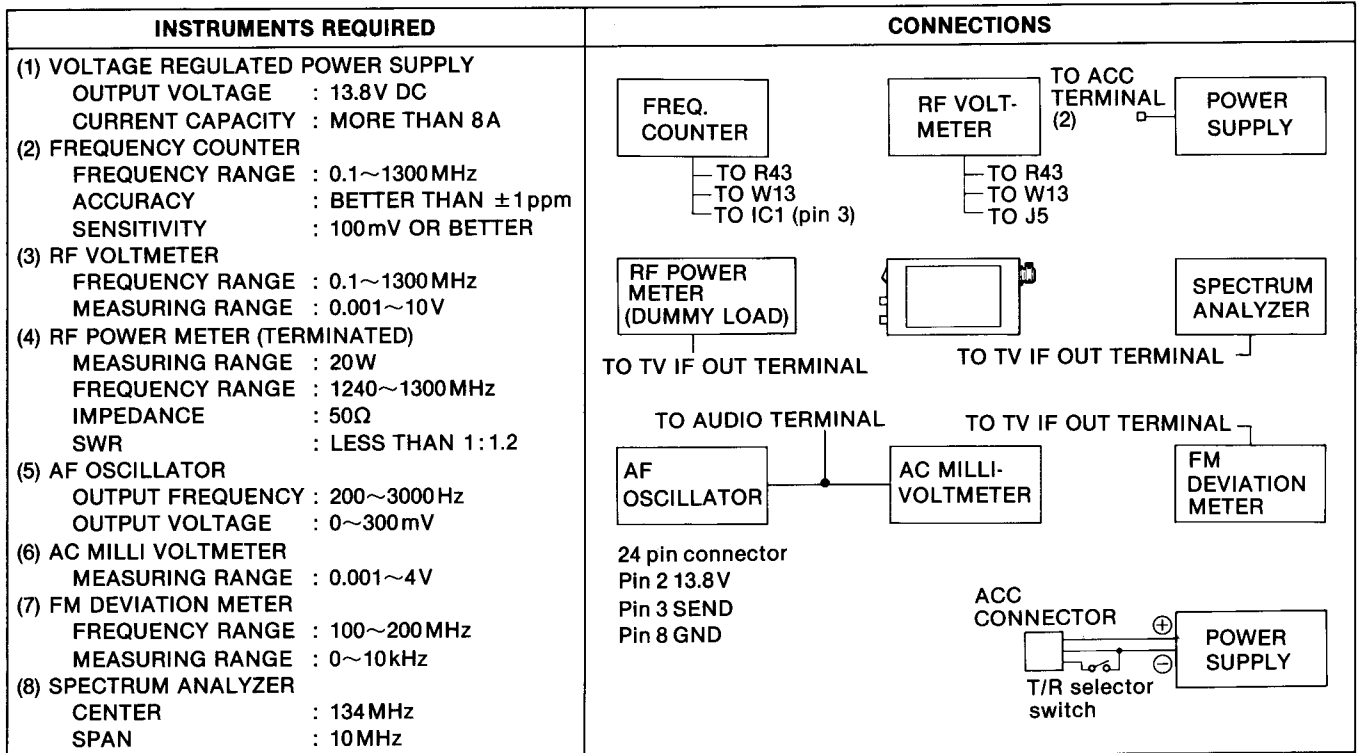

ADJUSTMENT	ADJUSTMENT CONDITION	UNIT	MEASUREMENT LOCATION	VALUE	UNIT	ADJUST
LO	1 S1: L position	ATV	Connect a frequency counter to R43.	195.11 MHz ± 10 (#02)	ATV	C47
	2 S1: H position			191.11 MHz ± 10 (#03)		
					189.11 MHz ± 10 (#04)	
NOTE: Repeat steps 1 and 2 several time						
	3 • Transmit	ATV	Connect an RF voltmeter to R43.	More than 0.15V	—	Verify
TX LO	1 • Transmit	ATV	Connect a frequency counter to W13.	133.86MHz	ATV	C30
	2		Connect an RF voltmeter to W13.	Approx. 0.4V		
VOICE CARRIER	1 • Transmit	ATV	Connect a frequency counter to IC1 (pin 3).	4.500 MHz (#02) 5.500 MHz (#03, 04)	ATV	L1
TRANSMIT	1 RF POWER CONTROL: Max. clockwise Connect RF power meter to TV IF OUT terminal • Transmit	ATV	Connect an RF voltmeter to J5.	Maximum output	ATV	L4~L6
	2 RF POWER CONTROL: Turn slowly the control knob from minimum to maximum position.			0.5V		
DEVIATION	1 • R12: Cut the wire. • R1: Max. counter-clockwise Apply AF input (1kHz, 2mV) to the AUDIO terminal • Transmit.	REAR PANEL	Connect FM deviation meter to TV IF OUT terminal via coupling condenser.	± 25 kHz (#02)	ATV	R62
	2 Vary the output frequency of AF oscillator from 300Hz to 7500Hz			± 50 kHz (#03, 04)		
NOTE: If measured frequency deviation is over the levels such as ± 25 kHz (#02), ± 50 kHz (#03, #04), repeat the adjustment. After adjustment, connect the cut portion of R12 (at step 1).						

ADJUSTMENT	ADJUSTMENT CONDITION	UNIT	MEASUREMENT LOCATION	VALUE	UNIT	ADJUST
VIDEO GAIN	1 Mode: Transmit shoot the logarithmic gray scale chart	ATV	Connect a camera and a monitor TV.	Normal (clear picture)	ATV	R2

ATV UNIT

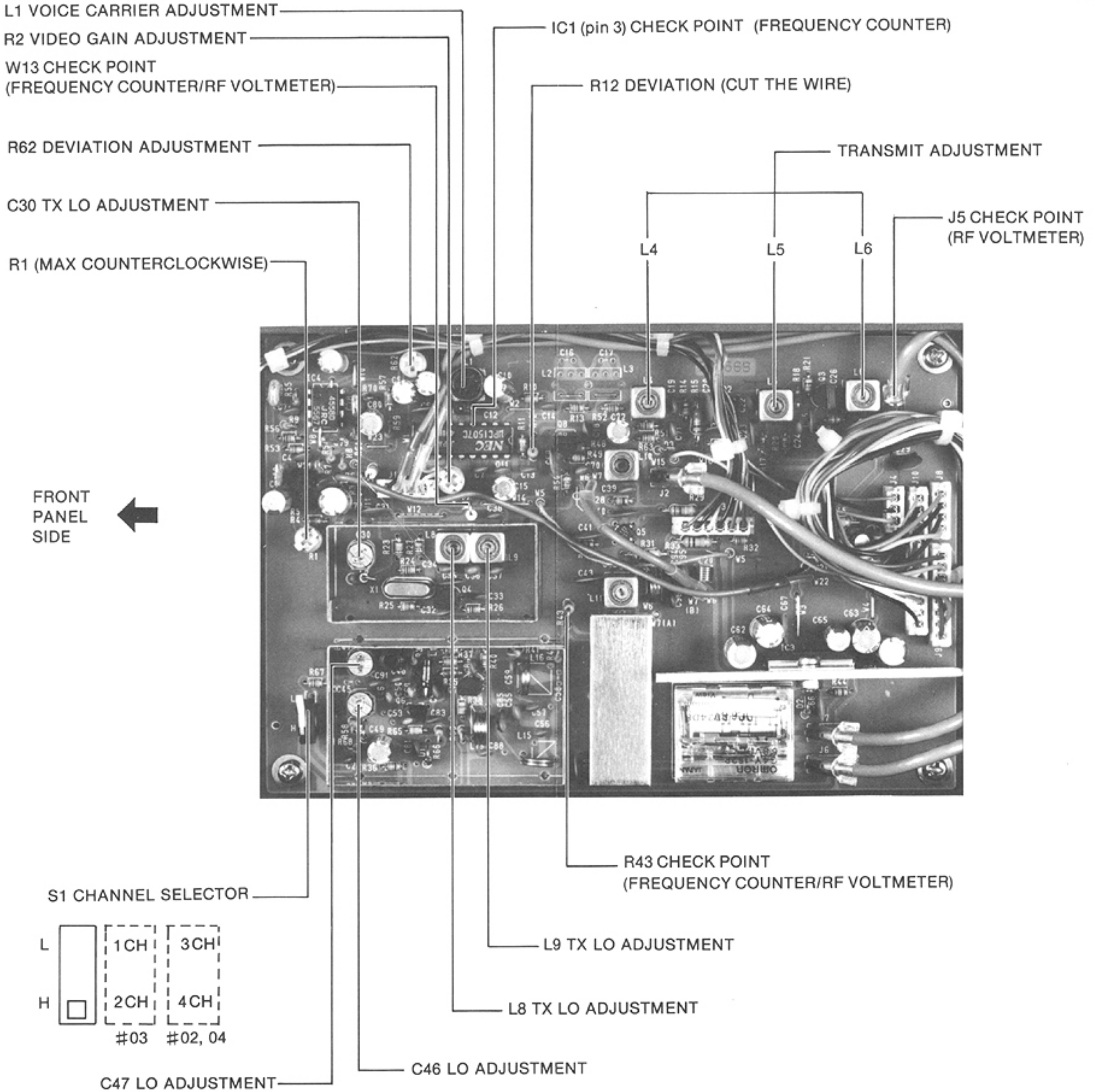

1. AUDIO CIRCUIT

The audio signal passes through the ATV UNIT connector J1 and R1 from the audio input jack (J3) at the rear panel, and is amplified at Q1 (audio amplifier).

R1 is for audio gain control.

The signal amplified at Q1 is input to IC4A via the differentiation circuit (preemphasis circuit with 6dB/octave characteristics) comprising C3 and R9.

IC4A combines amplifiers and the I.D.C. limits frequency deviation. IC4B is a low-pass filter comprising R57, R61, C78 and C79 which cuts off audio bandwidths. Then the modulation degree of the audio output signal is controlled by deviation set (R62) and input to IC1 (pin 6).

2. VIDEO CIRCUIT

The video signal from the video input terminal of J4 is input to pins 3 and 4 of connector J1 of ATV UNIT via R2.

R2 is for video gain control.

The signal is input to IC1 (pin 16).

3. VIDEO CARRIER OSCILLATION CIRCUIT

The oscillation circuit consists of Q4 and X1.

In transmit mode, T8V is applied to the oscillation circuit and then X1 (44.62MHz) is oscillated.

This oscillation signal is tripled, and outputs to IC1 (pin 11).

4. RF MODULATION CIRCUIT

IC1 is an IC for frequency conversion of the video and audio signals to 133MHz band, and is composed of the video clamper circuit, white clipper circuit, video signal AM modulation circuit, and the audio carrier oscillation circuit.

L1 and C10 are parts determine the oscillation frequency of audio carrier oscillation circuit which oscillates 4.5MHz (#02) and 5.5MHz (#03, #04) respectively at the user destination.

J11 is a ATV signal emission type terminal for switching A9 and A5.

The terminal can be used for A5 by connecting the short pin.

The audio carrier signal output from IC1 (pin 2) is mixed with the video carrier signal from pin 15 and is input to L4 as the TV IF signal.

5. ATV ALC, TRANSMIT AMP CIRCUIT

ALC signal from the IC-1271A/E is input to ALC control circuit consisting of D3, R63, R51, C71 and C72.

The TV IF signal passes through the tuning circuit comprising L4 and C19, and is amplified at the manual control amplifier comprising the RF amplifier (Q2) and the RF power control (R2) on the front panel. The amplified signal passes through buffer (Q3) and is output to J5 TX IF terminal.

6. SELF-OSCILLATION CIRCUIT

Q6 comprises a clap oscillator circuit. When switch S1 in the ATV UNIT is set to "H" position, frequencies of 201.11MHz (#02), 198.11MHz (#03), 196.11MHz (#04) are oscillated at C46, C91, C47, C50 and L14. When S1 is set to "L" position, frequencies of 195.11MHz (#02), 191.11MHz (#03) and 189.11MHz (#04) are oscillated at C47, C50 and L14, respectively. Then, after passing through buffer Q7, doubled and tripled harmonics signals are eliminated at a low-pass filter consisting of L15, L14, C55, C56 and C57. The signals are input to a doublebalanced mixer (IC2) through an attenuator circuit consisting of R41, R42 and R43, and are converted to the television frequency.

7. RECEIVE AMP AND TRANSMIT MONITOR

The IF signal input to the TV IF IN terminal from IC-1271A/E undergoes gain adjustment at the manual control amplifier comprising RF amplifier Q5 and the RX gain control R1 on the front panel.

After being amplified, the signal is input to the double-balanced mixer comprising IC2, L12 and L13. This signal is converted to NTSC (#02) or PAL (#03, 04) signal, and the unrequired frequencies are cut by the BPF (F11).

These are then output to the TV (VHF) terminal from RL1 and J7.

In the ATV TRANSMIT mode, the TV IF signal from IC1 is input via buffer amplifier Q8 to the double-balanced mixer comprising L12, L13 and IC2, and converted to the TV frequency.

8. ANTENNA SELECTOR

When the power is ON, 8V from IC3 is supplied to RL1, and is output to the monitors of household TVs or video recorders in the transmit and receive modes. When the power is OFF, RL1 is turned OFF, and the VHF TV signal is output.

9. POWER SUPPLY CIRCUIT AND RECEIVE/TRANSMIT CONTROL CIRCUITS

13.8V (power source) and the transmit/receive control (SEND) signal are supplied to TV-1200 from IC-1271A/E.

13.8V passes through the power switch S1 on the front panel and L17 in the ATV UNIT, while the transmit/receive control signal (SEND) is input to IC3 via R45.

The power supply circuit comprising IC3, C61, C62, C63, C64 and C65 outputs constant voltages of 8V, T8V and R8V which are supplied to the respective circuits.

SECTION 6 VOLTAGE/CIRCUIT DIAGRAMS

EF UNIT

TV-1200

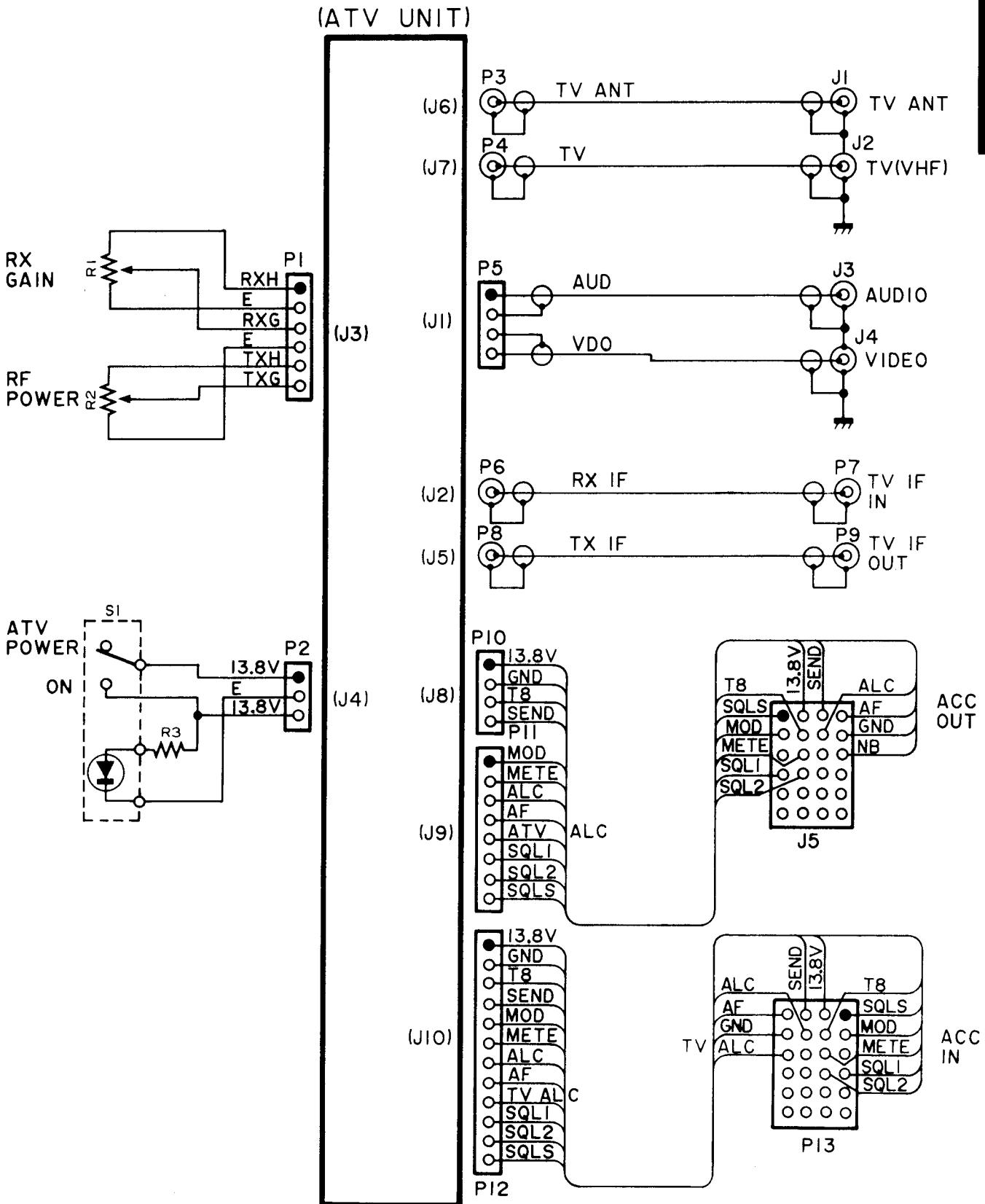

ATV UNIT

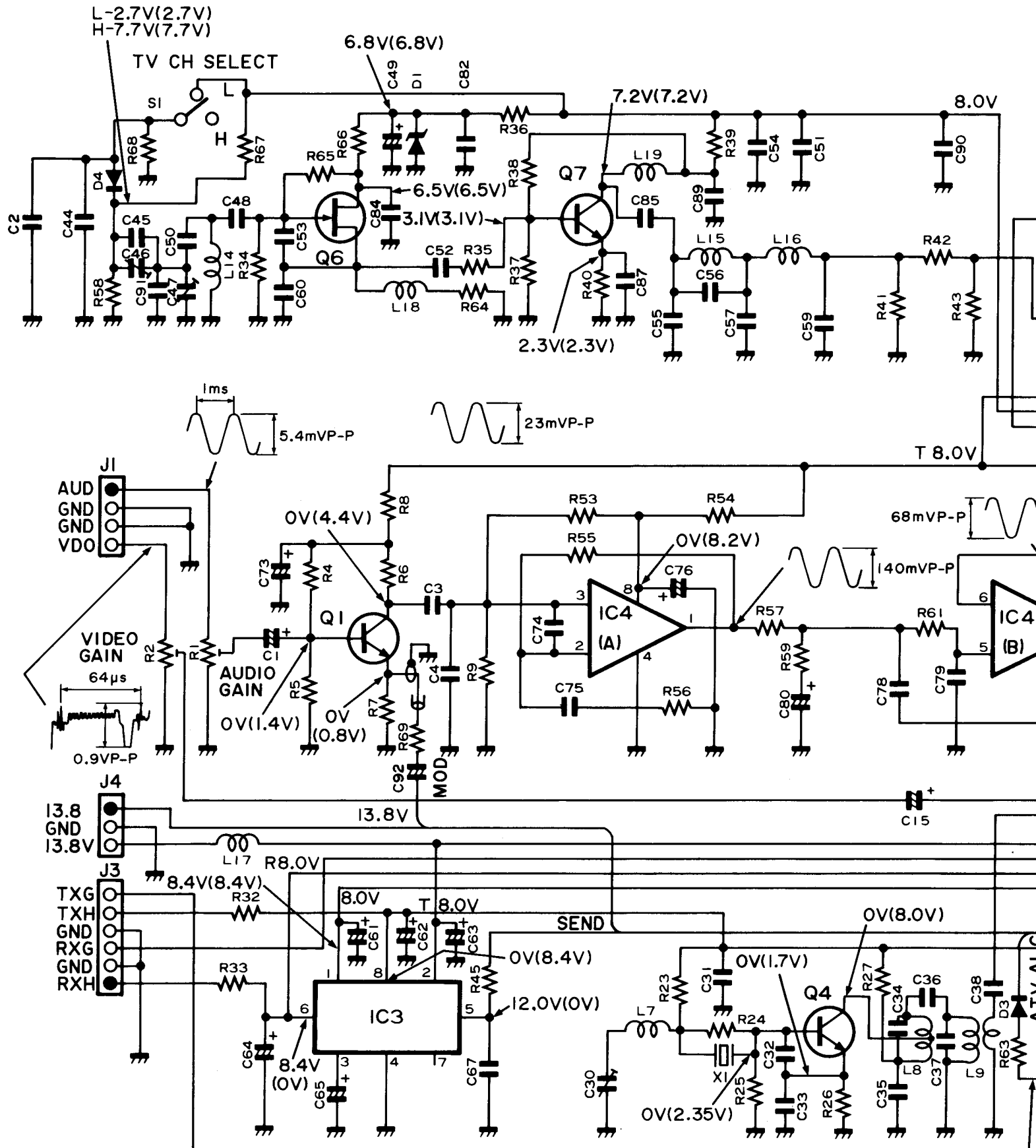

MEASUREMENT CONDITIONS

- TV-1200 UNIT: RF POWER CONTROL AND RF GAIN CONTROL MAX
 - VIDEO CAMERA: INPUT VIDEO SIGNAL
 - AUDIO SIGNAL GENERATOR: INPUT AUDIO SIGNAL (f=1kHz, 2mV rms)
- ()... Voltage values at Receive mode

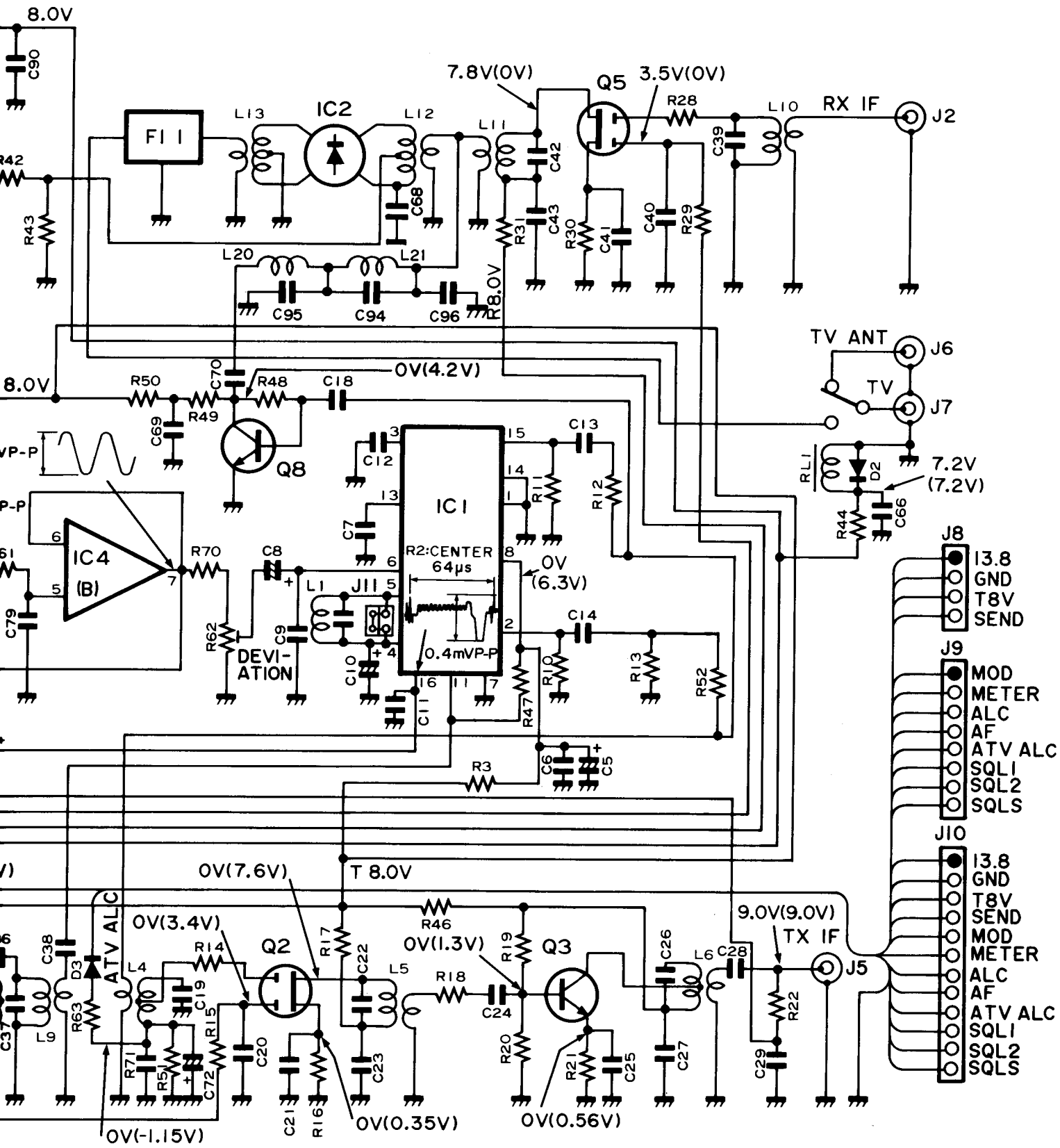

SECTION 7 BOARD LAYOUT

ATV UNIT

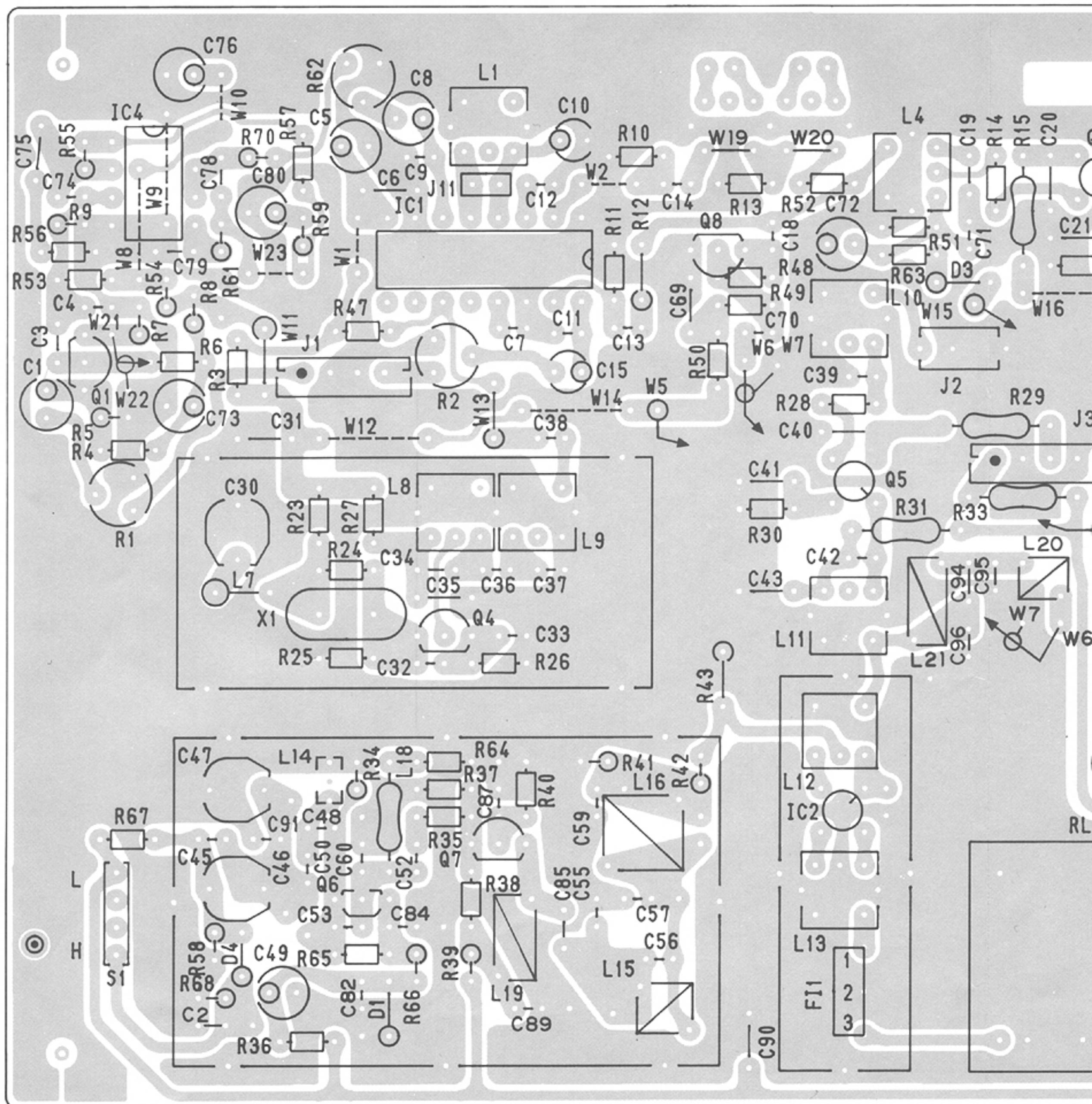
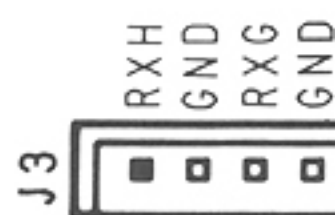
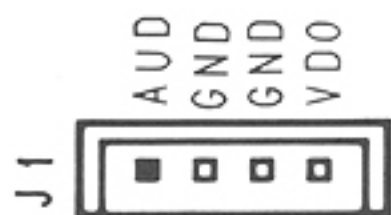

RXH
GND
RXG
GND
TXH
TXG

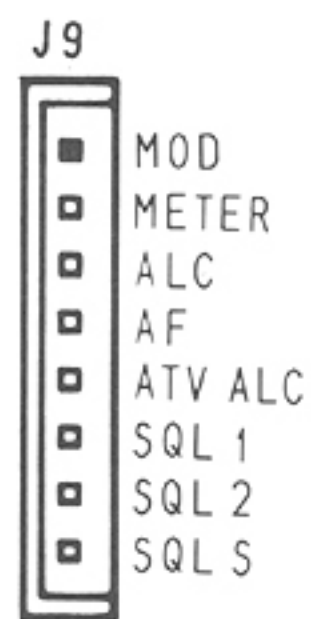
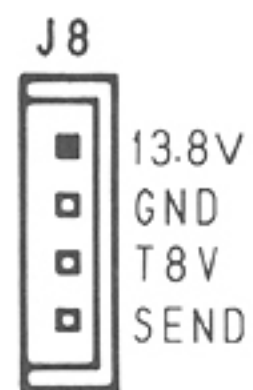
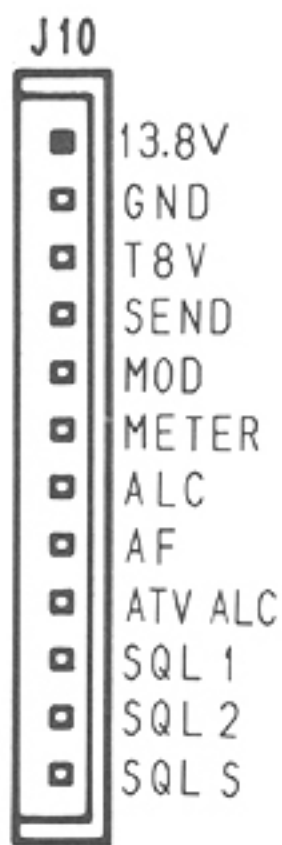
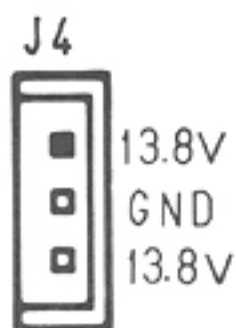
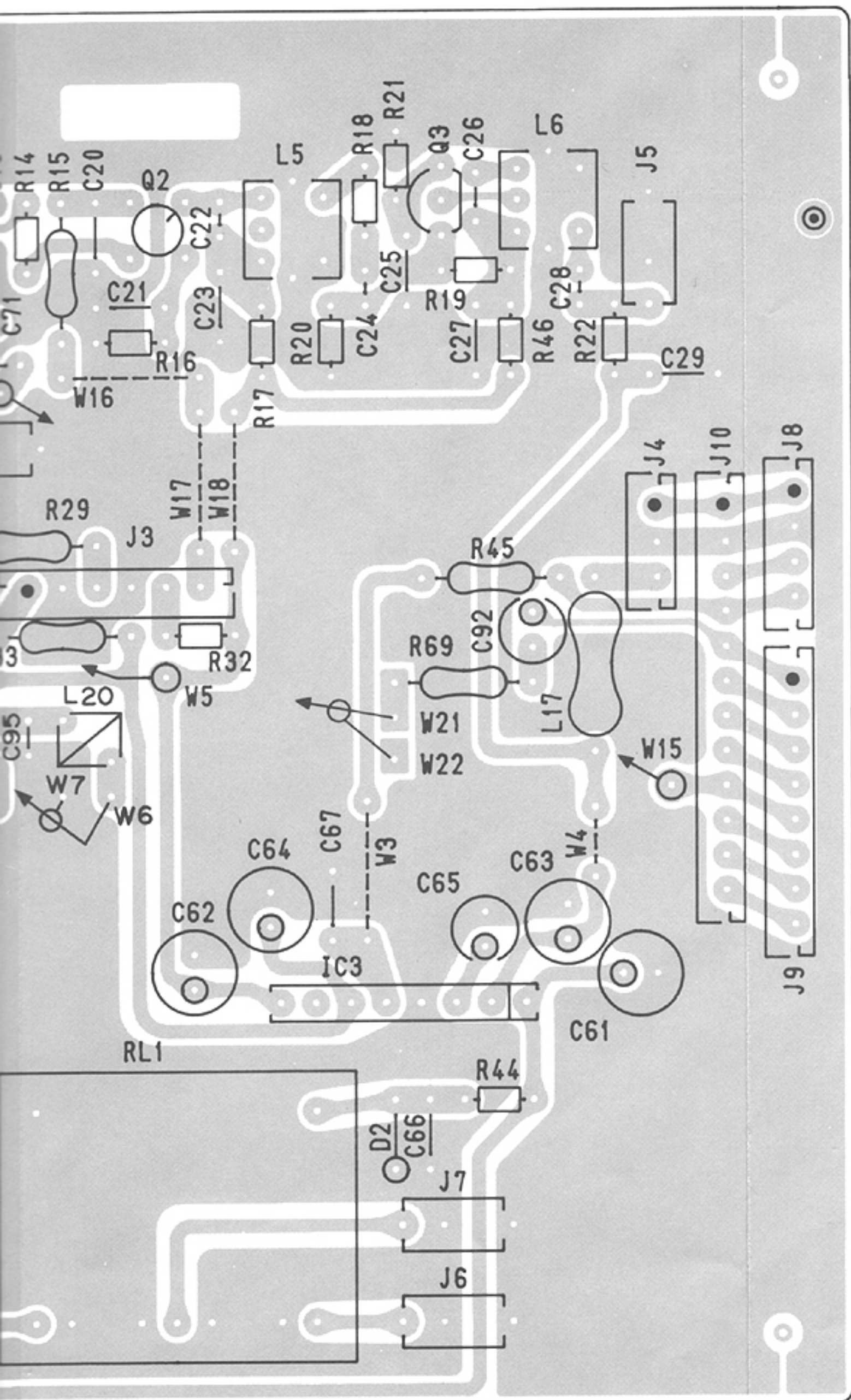

SECTION 8 IC SPECIFICATIONS

TV-1200

MB3756 (VOLTAGE REGULATOR)

MAXIMUM RATINGS ($T_a = 25^\circ\text{C}$)

Description	Symbol	Rating	Unit
Input Voltage	V_{IN}	18	V
Power Dissipation	P_D	1 *1	W
		4 *2	W
Operating Temperature	T_{OPR}	$-30 \sim +80$	$^\circ\text{C}$
Storage Temperature	T_{STG}	$-55 \sim +150$	$^\circ\text{C}$

*1: No Heat Sink $T_A \leq 70^\circ\text{C}$, *2: Infinite Heat Sink $T_C \leq 70^\circ\text{C}$

PIN CONNECTIONS

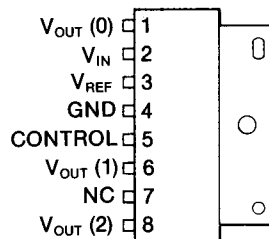

NJM4558D (DUAL LOW NOISE AMPLIFIER)

MAXIMUM RATINGS ($T_a = 25^\circ\text{C}$)

Description	Symbol	Rating	Unit
Supply Voltage	V_{CC}	± 18	V
Input Voltage	V_{IN}	± 15	V
Operating Temperature	T_{OPR}	$-20 \sim +75$	$^\circ\text{C}$
Storage Temperature	T_{STG}	$-40 \sim +125$	$^\circ\text{C}$

PIN CONNECTIONS

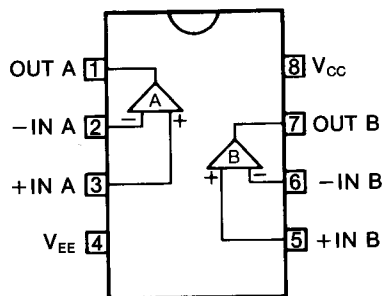

ND487C1-3R (DOUBLE-BALANCED MIXER)

MAXIMUM RATINGS

Description	Symbol	Rating	Unit
Junction Temperature	T_J	+150	°C
Storage Temperature	T_{STG}	-65 ~ +150	°C

PIN CONNECTIONS

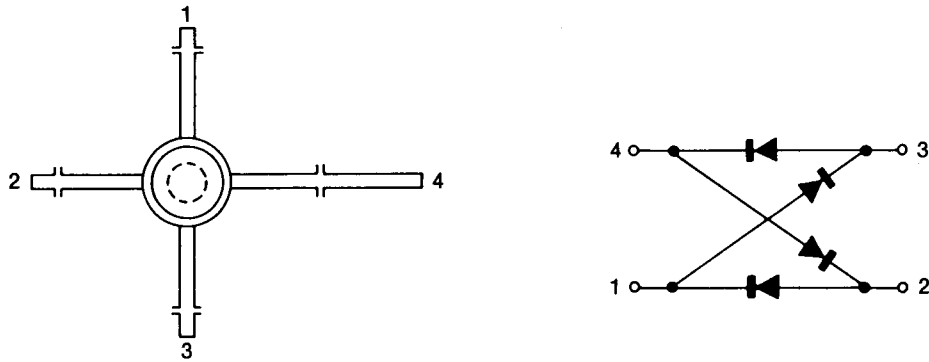

μPC1507C (RF MODULATOR)

MAXIMUM RATINGS

Description	Symbol	Rating	Unit
Supply Voltage	V_{CC}	9.5	V
Power Dissipation	P_D	350	mW
Operating Temperature	T_{OPR}	-10 ~ +70	°C
Storage Temperature	T_{STG}	-40 ~ +125	°C

PIN CONNECTIONS

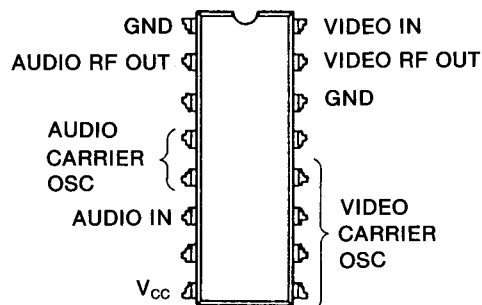

SECTION 9 PARTS LIST

[EF UNIT]

REF. NO.	DESCRIPTION	PART NO.
R1	Variable	RKDA1010ZA 10kA
R2	Variable	RKDA1010ZA 10kA
R3	Resistor	470 R20
J1	Connector	FR-1
J2	Connector	FR-1
J3	Connector	AT-700
J4	Connector	AT-700
J5	Connector	1625-24R
P1	Connector	EHR-06
P2	Connector	EHR-03
P3	Connector	TMP-P01X-A1
P4	Connector	TMP-P01X-A1
P5	Connector	EHR-04
P6	Connector	TMP-P01X-A1
P7	Connector	TPM-13A
P8	Connector	TMP-P01X-A1
P9	Connector	TPM-13A
P10	Connector	EHR-04
P11	Connector	EHR-08
P12	Connector	EHR-12
P13	Connector	1625-24P
S1	Switch	SC-WL01A-02BB
EP1	Plastic Grommet	NC-1
EP2	Plastic Grommet	K-375-125
EP3	Plastic Grommet	K-375-125
MP1	456 Case (A)	20235
MP2	456 Case (B)	30437
MP3	N-58B Knob	42102
MP4	Standoff (G) I=9.5	40274
MP5	ICOM Screw (B)	5
MP6	Screw (C)	3×6
MP7	ICOM Screw (B)	5
MP9	Screw PH	M2.6×6
MP10	EXT Toothed	M3
W1	Wire	23/01/245/B06/W03
W2	Wire	23/00/245/B06/W03
W3	Wire	23/04/245/B06/W03
W4	Wire	23/00/215/B06/W03
W5	Wire	23/05/215/B06/W03
W6	Wire	23/06/215/B06/W03
W7	Wire	23/02/185/B06/W03
W8	Wire	23/00/190/B06/W03
W9	Wire	23/03/195/B06/W03
W10	Wire	62/99/080/C31/W99D
W11		08 D
W12	Wire	62/99/080/C31/W99D
W13		08 D

[EF UNIT]

REF. NO.	DESCRIPTION	PART NO.
W14	Wire	51/02/245/B06A/W11A
W15		08 /B06A/ A
W16	Wire	61/99/255/B06A/W11A
W17		08 /B06A/ A
W18		OPC-108A
W19		OPC-108B
W20		OPC-047
W21		OPC-110

TV-1200

[ATV UNIT]

REF. NO.	DESCRIPTION	PART NO.
IC1	IC	μPC1507C
IC2	IC	ND487-C1-3R
IC3	IC	MB3756
IC4	IC	NJM4558D
Q1	Transistor	2SC1571 G
Q2	FET	3SK122 K
Q3	Transistor	2SC763 C
Q4	Transistor	2SC763 C
Q5	FET	3SK122 K
Q6	FET	2SK192A Y
Q7	Transistor	2SC2026
Q8	Transistor	2SC763 C
D1	Zener	RD6.8E B3
D2	Diode	1SS55
D3	Diode	1SS53
D4	Diode	1SS53
F11	Filter	US 3/4 b2
X1	Crystal	CR151
L1	Coil	119AE-15483Z
L4	Coil	LS-145
L5	Coil	LS-145
L6	Coil	LS-145
L7	Coil	LW-19
L8	Coil	LS-145
L9	Coil	LS-145
L10	Coil	LS-145
L11	Coil	LS-145
L12	Coil	LR-116
L13	Coil	LR-116
L14	Coil	LB-180
L15	Coil	LA-262
L16	Coil	LA-262
L17	Coil	LAL04NA 100K
L18	Coil	LW-19
L19	Coil	LA-264
L20	Coil	LA-236
L21	Coil	LA-263
R1	Trimmer	RHB0C1431A 10k
R2	Trimmer	RHB0C1324A 1k
R3	Resistor	82 R20
R4	Resistor	12k R20
R5	Resistor	1.8k ELR20
R6	Resistor	2.2k R20
R7	Resistor	470 ELR20
R8	Resistor	100 ELR20
R9	Resistor	270k ELR20
R10	Resistor	3.3k R20
R11	Resistor	3.3k R20
R12	Resistor	82 R25
R13	Resistor	22 R20
R14	Resistor	47 R20
R15	Resistor	100k R25

[ATV UNIT]

REF. NO.	DESCRIPTION	PART NO.
R16	Resistor	39 R20
R17	Resistor	100 R20
R18	Resistor	10 R20
R19	Resistor	3.9k R20
R20	Resistor	1k R20
R21	Resistor	47 R20
R22	Resistor	1k R20
R23	Resistor	10k R20
R24	Resistor	1k R20
R25	Resistor	4.7k R20
R26	Resistor	1k R20
R27	Resistor	100 R20
R28	Resistor	47 R20
R29	Resistor	100k R25
R30	Resistor	68 R20
R31	Resistor	100 R25
R32	Resistor	10k R20
R33	Resistor	10k R25
R34	Resistor	470k ELR20
R35	Resistor	220 R20
R36	Resistor	56 R20
R37	Resistor	5.6k R20
R38	Resistor	4.7k R20
R39	Resistor	47 ELR20
R40	Resistor	100 R20
R41	Resistor	100 ELR20
R42	Resistor	68 ELR20
R43	Resistor	100 R25
R44	Resistor	18 R20
R45	Resistor	100 R25
R46	Resistor	100 R20
R47	Resistor	1.5k R20
R48	Resistor	47k R20
R49	Resistor	470 R20
R50	Resistor	100 R20
R51	Resistor	1M R20
R52	Resistor	22 R20
R53	Resistor	220k R20
R54	Resistor	47 ELR20
R55	Resistor	220k ELR20
R56	Resistor	1k R20
R57	Resistor	15k R20
R58	Resistor	4.7k ELR20
R59	Resistor	15k ELR20
R61	Resistor	8.2k ELR20
R62	Trimmer	RHB0CJ401A 22k
R63	Resistor	10k R20
R64	Resistor	100 R20
R65	Resistor	470k R20
R66	Resistor	100 ELR20
R67	Resistor	10k R20
R68	Resistor	100k R20
R69	Resistor	100 R25
R70	Resistor	100k ELR20
C1	Electrolytic	1 50V
C2	Ceramic	0.001 50V
C3	Mylar	0.01 50V
C4	Ceramic	100P 50V
C5	Electrolytic	47 10V
C6	Ceramic	0.0047 50V
C7	Ceramic	0.001 50V
C8	Electrolytic	1 50V

[ATV UNIT]

REF. NO.	DESCRIPTION	PART NO.	
C9	Ceramic	47P	50V
C10	Electrolytic	0.47	50V
C11	Ceramic	47P	50V
C12	Ceramic	8P	50V
C13	Ceramic	47P	50V
C14	Ceramic	47P	50V
C15	Electrolytic	1	50V
C18	Ceramic	100P	50V
C19	Ceramic	6P	50V
C20	Ceramic	0.0047	50V
C21	Ceramic	0.0047	50V
C22	Ceramic	4P	50V
C23	Ceramic	0.0047	50V
C24	Ceramic	47P	50V
C25	Ceramic	220P	50V
C26	Ceramic	6P	50V
C27	Ceramic	0.0047	50V
C28	Ceramic	47P	50V
C29	Ceramic	0.0047	50V
C30	Trimmer	VCT51F126A 30P	
C31	Ceramic	0.0047	50V
C32	Ceramic	39P	50V
C33	Ceramic	47P	50V
C34	Ceramic	6P	50V
C35	Ceramic	0.0047	50V
C36	Ceramic	0.5P	50V
C37	Ceramic	6P	50V
C38	Ceramic	47P	50V
C39	Ceramic	4P	50V
C40	Ceramic	0.0047	50V
C41	Ceramic	0.0047	50V
C42	Ceramic	3P	50V
C43	Ceramic	0.0047	50V
C46	Trimmer	VCT51C143A 10P (#03, 04)	
C46	Trimmer	VCT51A123A 6P (#02 only)	
C47	Trimmer	VCT51C143A 10P (#03, 04)	
C47	Trimmer	VCT51A123A 6P (#02 only)	
C48	Ceramic	10P	50V CH
C49	Electrolytic	10	16V
C50	Ceramic	8P	50V TH
C52	Ceramic	2P	50V
C53	Ceramic	5P	50V CH
C55	Ceramic	18P	50V
C56	Ceramic	2P	50V
C57	Ceramic	36P	50V
C59	Ceramic	18P	50V
C60	Ceramic	5P	50V CH
C61	Electrolytic	47	16V
C62	Electrolytic	47	16V
C63	Electrolytic	47	16V
C64	Electrolytic	47	16V
C65	Electrolytic	4.7	25V
C66	Ceramic	0.0047	50V
C67	Ceramic	0.0047	50V
C69	Ceramic	0.0047	50V
C70	Ceramic	3P	50V
C71	Ceramic	0.001	50V
C72	Electrolytic	0.47	50V
C73	Electrolytic	100	50V
C74	Ceramic	100P	50V

[ATV UNIT]

REF. NO.	DESCRIPTION	PART NO.	
C75	Mylar	0.022	50V
C76	Electrolytic	10	10V
C78	Mylar	0.0039	50V
C79	Mylar	0.0022	50V
C80	Electrolytic	1	50V
C82	Ceramic	0.001	50V
C84	Ceramic	0.001	50V
C85	Ceramic	6P	50V
C87	Ceramic	0.001	50V
C89	Ceramic	0.001	50V
C90	Ceramic	0.0047	50V
C91	Ceramic	6P	50V UJ
C92	Electrolytic	4.7	25V BP
C94	Ceramic	5P	50V
C95	Ceramic	30P	50V
C96	Ceramic	30P	50V
RL1	Relay	G4Y-152P 6.8VDC	
J1	Connector	B04B-EH-S	
J2	Connector	TMP-J01X-A2	
J3	Connector	B06B-EH-S	
J4	Connector	B03B-EH-S	
J5	Connector	TMP-J01X-A2	
J6	Connector	TMP-J01X-A2	
J7	Connector	TMP-J01X-A2	
J8	Connector	B04B-EH-S	
J9	Connector	B08B-EH-S	
J10	Connector	B12B-EH-S	
J11	Connector	IMSA-9201B-1-02-T	
P1	Connector	IMSA-9201-HT	
S1	Switch	EVQ-RBA	
EP1	P.C.B	B-1056A	
MP1	Shield Case	41556	
MP2	Shield Case Cover	41557	
MP3	Shield Case (A)	41699	
MP4	Shield Case Cover (A)	41700	
MP5	220 Shield Case	42199	
MP6	220 Shield Case Cover	42200	
MP7	Heat Sink	41714	
MP8	Screw (A) 3 × 6		
MP9	Nut		
W1	Jumper	IPS-1041-2	
W2	Jumper	IPS-1041-2	
W3	Jumper	IPS-1041-4	
W4	Jumper	IPS-1041-2	
W5	Wire	23/03/060/C21/C21	
W6	Wire	61/99/070/W11A/W11A	
W7		08	A A
W8	Jumper	IPS-1041-4	
W9	Jumper	IPS-1041-4	
W10	Jumper	IPS-1041-2	

TV-1200

[ATV UNIT]

REF. NO.	DESCRIPTION	PART NO.
W11	Jumper	JPW-02H
W12	Jumper	IPS-1041-4
W13	Jumper	JPW-02H
W14	Jumper	IPS-1041-4
W15	Wire	23/04/080/C21/C21
W16	Jumper	IPS-1041-4
W17	Jumper	IPS-1041-4
W18	Jumper	IPS-1041-4
W19	Jumper	IPS-1041-2
W20	Jumper	IPS-1041-2
W21	Wire	51/02/140/W11A/W11A
W22		08 A A
W23	Jumper	IPS-1041-2

TV-1200

TV-1200 SCHEMATIC DIAGRAM

EXPORT VERSION

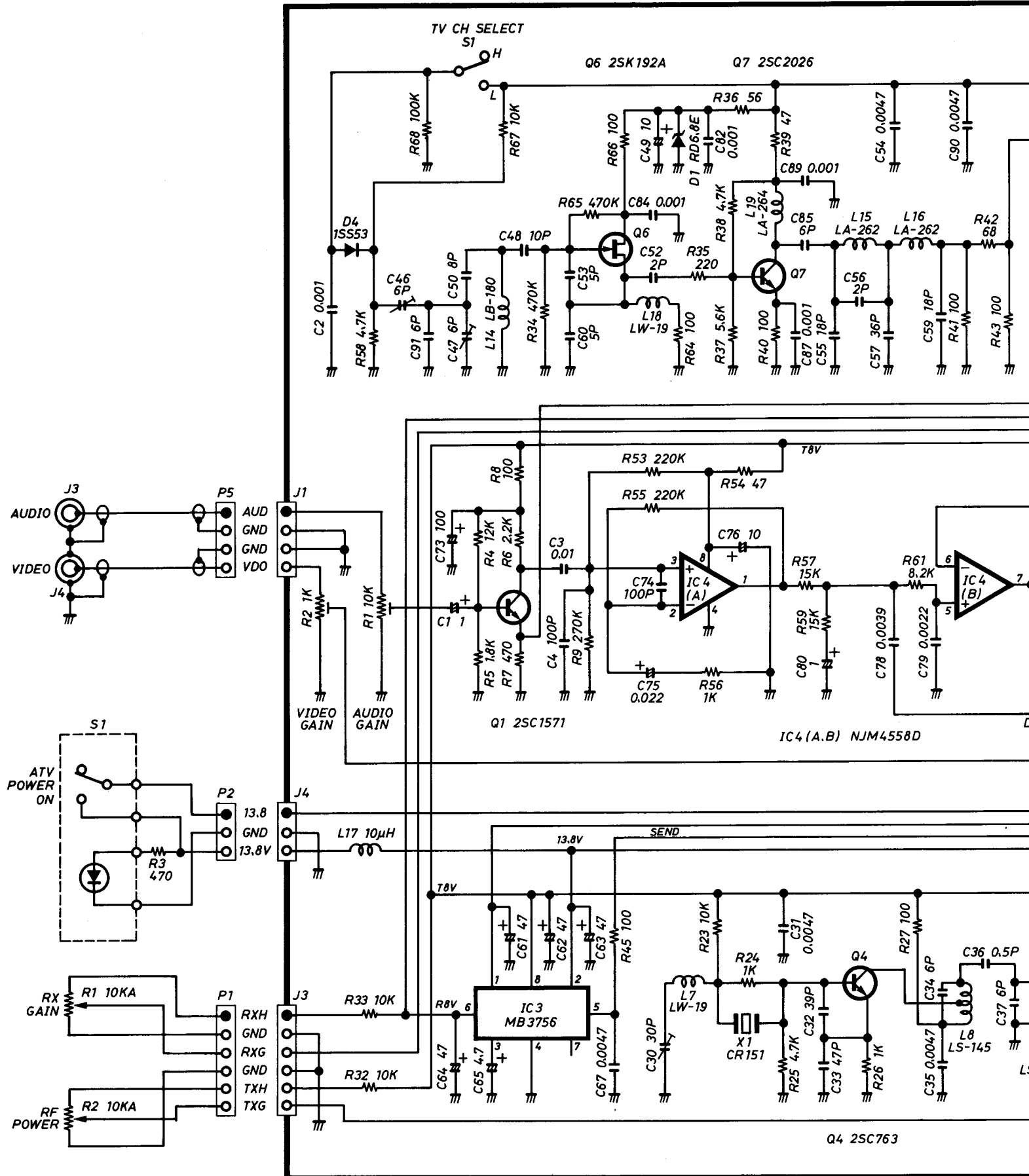

IC DIAGRAM

ATV UNIT

25C2026

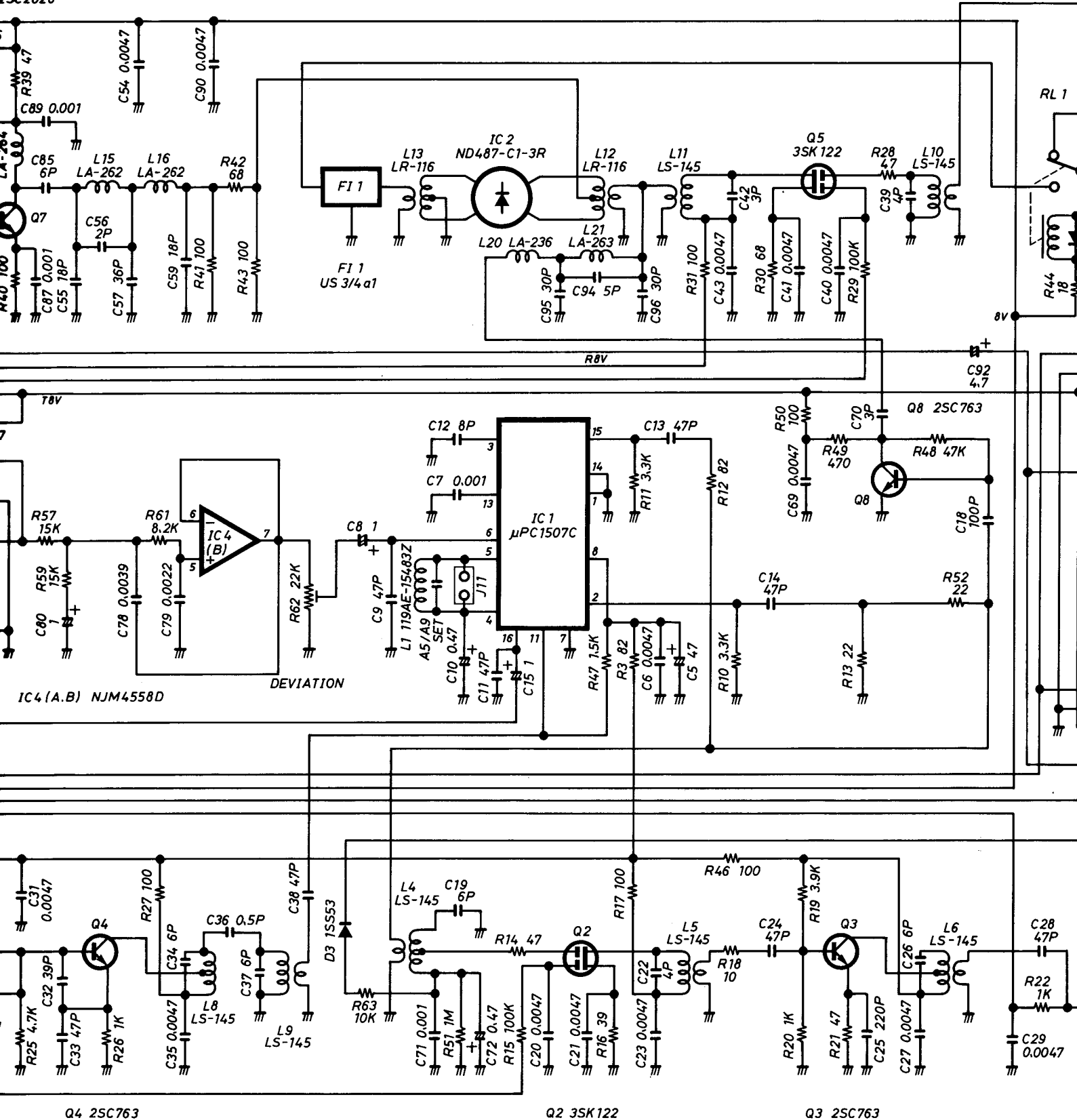

Q4 25C763

Q2 35K122

Q3 25C763

