

HEATHKIT[®] MANUAL

for the
**SINGLE SIDEBAND
TRANSCEIVER**
Model SB-104A
Assembly 595-1992-06



HEATH COMPANY • BENTON HARBOR, MICHIGAN

HEATH COMPANY PHONE DIRECTORY

The following telephone numbers are direct lines to the departments listed:

Kit orders and delivery information (616) 982-3411
Credit (616) 982-3561
Replacement Parts (616) 982-3571

Technical Assistance Phone Numbers

8:00 A.M. to 12 P.M. and 1:00 P.M. to 4:30 P.M., EST, Weekdays Only
R/C, Audio, and Electronic Organs (616) 982-3310
Amateur Radio (616) 982-3296
Test Equipment, Weather Instruments and
Home Clocks (616) 982-3315
Television (616) 982-3307
Aircraft, Marine, Security, Scanners, Automotive,
Appliances and General Products (616) 982-3496
Computers — Hardware (616) 982-3309
Computers — Software:
Operating Systems, Languages, Utilities (616) 982-3860
Application Programs (616) 982-3884
Heath Craft Wood Works (616) 982-3423



YOUR HEATHKIT 90-DAY LIMITED WARRANTY

Consumer Protection Plan for Heathkit Consumer Products

Welcome to the Heath family. We believe you will enjoy assembling your kit and will be pleased with its performance. Please read this Consumer Protection Plan carefully. It is a "LIMITED WARRANTY" as defined in the U.S. Consumer Product Warranty and Federal Trade Commission Improvement Act. This warranty gives you specific legal rights, and you may also have other rights which vary from state to state.

Heath's Responsibility

PARTS — Replacements for factory defective parts will be supplied free for 90 days from date of purchase. Replacement parts are warranted for the remaining portion of the original warranty period. You can obtain warranty parts direct from Heath Company by writing or telephoning us at (616) 982-3571. And we will pay shipping charges to get those parts to you . . . anywhere in the world.

SERVICE LABOR — For a period of 90 days from the date of purchase, any malfunction caused by defective parts or error in design will be corrected at no charge to you. You must deliver the unit at your expense to the Heath factory, any Heathkit Electronic Center (units of Veritechnology Electronics Corporation), or any of our authorized overseas distributors.

TECHNICAL CONSULTATION — You will receive free consultation on any problem you might encounter in the assembly or use of your Heathkit product. Just drop us a line or give us a call. Sorry, we cannot accept collect calls.

NOT COVERED — The correction of assembly errors, adjustments, calibration, and damage due to misuse, abuse, or negligence are not covered by the warranty. Use of corrosive solder and/or the unauthorized modification of the product or of any furnished component, will void this warranty in its entirety. This warranty does not include reimbursement for inconvenience, loss of use, customer assembly, set-up time, or unauthorized service.

This warranty covers only Heath products and is not extended to other equipment or components that a customer uses in conjunction with our products.

SUCH REPAIR AND REPLACEMENT SHALL BE THE SOLE REMEDY OF THE CUSTOMER AND THERE SHALL BE NO LIABILITY ON THE PART OF HEATH FOR ANY SPECIAL, INDIRECT, INCIDENTAL OR CONSEQUENTIAL DAMAGES, INCLUDING BUT NOT LIMITED TO ANY LOSS OF BUSINESS OR PROFITS, WHETHER OR NOT FORSEEABLE.

Some states do not allow the exclusion or limitation of incidental or consequential damages, so the above limitation or exclusion may not apply to you.

Owner's Responsibility

EFFECTIVE WARRANTY DATE — Warranty begins on the date of first consumer purchase. You must supply a copy of your proof of purchase when you request warranty service or parts.

ASSEMBLY — Before seeking warranty service, you should complete the assembly by carefully following the manual instructions. Heathkit service agencies cannot complete assembly and adjustments that are customer's responsibility.

ACCESSORY EQUIPMENT — Performance malfunctions involving other non-Heath accessory equipment, (antennas, audio components, computer peripherals and software, etc.) are not covered by this warranty and are the owner's responsibility.

SHIPPING UNITS — Follow the packing instructions published in the assembly manuals. Damage due to inadequate packing cannot be repaired under warranty.

If you are not satisfied with our service (warranty or otherwise) or our products, write directly to our Director of Customer Service, Heath Company, Benton Harbor MI 49022. He will make certain your problems receive immediate, personal attention.

Heathkit® Manual

for the

SINGLE SIDEBAND TRANSCEIVER

Model SB-104A

Assembly

595-1992-06



HEATH COMPANY
BENTON HARBOR, MICHIGAN 49022

Copyright © 1977
Heath Company
All Rights Reserved
Printed in the United States of America



TABLE OF CONTENTS

<p>INTRODUCTION 1-3</p> <p>PARTS PACKAGING 1-5</p> <p>ASSEMBLY NOTES 1-7</p> <p>CIRCUIT BOARD ASSEMBLY 1-9</p> <p>VARIABLE FREQUENCY OSCILLATOR (VFO) AND EXTENDER BOARD</p> <p>Parts List 1-11</p> <p>Step-by-Step Assembly</p> <p style="padding-left: 20px;">Extender Circuit Board 1-17</p> <p style="padding-left: 20px;">Extender Block 1-18</p> <p style="padding-left: 20px;">Oscillator Circuit Board 1-19</p> <p style="padding-left: 20px;">Buffer Circuit Board 1-22</p> <p style="padding-left: 20px;">VFO Enclosure 1-25</p> <p>TRANSMITTER AUDIO/REG CIRCUIT BOARD</p> <p>Parts List 1-31</p> <p>Step-by-Step Assembly 1-35</p> <p>HFO/PREMIER CIRCUIT BOARD</p> <p>Parts List 1-41</p> <p>Step-by-Step Assembly 1-46</p> <p>CONVERTER, DISPLAY, AND COUNTER CIRCUIT BOARDS</p> <p>Parts List 1-55</p> <p>Step-by-Step Assembly 1-58</p> <p style="padding-left: 20px;">Converter Circuit Board 1-58</p> <p style="padding-left: 20px;">Display Circuit Board 1-61</p> <p style="padding-left: 20px;">Counter Circuit Board 1-65</p>	<p>VFO FILTER AND DRIVER CIRCUIT BOARD</p> <p>Parts List 1-73</p> <p>Step-by-Step Assembly 1-76</p> <p style="padding-left: 20px;">VFO Filter Circuit Board 1-76</p> <p style="padding-left: 20px;">Driver Circuit Board 1-77</p> <p>ALC/OUTPUT FILTER CIRCUIT BOARD</p> <p>Parts List 1-83</p> <p>Step-by-Step Assembly 1-86</p> <p>CARRIER GENERATOR/XTAL FILTER CIRCUIT BOARD</p> <p>Parts List 1-91</p> <p>Step-by-Step Assembly 1-95</p> <p>RECEIVER IF/AUDIO CIRCUIT BOARD</p> <p>Parts List 1-105</p> <p>Step-by-Step Assembly 1-110</p> <p>POWER AMPLIFIER CIRCUIT BOARD</p> <p>Parts List 1-119</p> <p>Step-by-Step Assembly 1-121</p> <p style="padding-left: 20px;">Transformer Assembly 1-125</p> <p style="padding-left: 20px;">Transistor Installation 1-129</p> <p>CHASSIS ASSEMBLY</p> <p>Parts List 1-133</p> <p>Step-by-Step Assembly 1-143</p> <p style="padding-left: 20px;">Chassis Parts Mounting 1-143</p> <p style="padding-left: 20px;">Chassis Wiring 1-149</p> <p style="padding-left: 20px;">Wiring Harness 1-158</p> <p style="padding-left: 20px;">Parts and Cables 1-166</p> <p style="padding-left: 20px;">Cable Harness 1-169</p> <p style="padding-left: 20px;">Rear Panel 1-172</p> <p style="padding-left: 20px;">Under-Chassis Wiring 1-178</p> <p style="padding-left: 20px;">Top Chassis 1-181</p> <p style="padding-left: 20px;">Front Panel and VFO Mounting 1-191</p> <p style="padding-left: 20px;">Under-Chassis Panel Mounting 1-197</p> <p style="padding-left: 20px;">Knobs and Shafts 1-198</p>
---	---

INTRODUCTION

The Heathkit Model SB-104A SSB and CW transceiver covers the high frequency amateur bands from 3.5 MHz through 29.7 MHz. It is entirely solid-state and delivers approximately 100 watts to the antenna. However, it can be instantly switched to QRP operation, in which case a minimum of one watt is delivered to the antenna. Broadbanding eliminates the necessity to "peak" circuits within a band. All that is necessary is just to turn the Band switch and select the desired frequency.

The frequency to which the Transceiver is tuned is electronically displayed, which eliminates the usual dial read-out. A unique frequency counter is employed which includes a crystal-controlled time base. Very high accuracy is maintained on all bands and any requirement for a calibrator is therefore eliminated. A red window, which provides subdued lighting and high visibility, covers the frequency display, the panel meter, and a space for station call letters.

The Vox Gain and Vox Delay controls are conveniently located on the front panel to facilitate adjustments for operators who work both CW and SSB. Vox or PTT is pushbutton-selected, and the AGC action can be switched to fast, slow, or off. Provision is made for ALC input from an amplifier, and relay contacts are available for switching an amplifier between transmit and receive.

The Transceiver operates from a 13.8 VDC power input, which can be furnished by a power supply or direct from a battery. The panel meter can be switched to read supply voltage or relative power output; in the receive mode, when it is switched to ALC, it acts as an S meter. The Power Amplifier circuit board carries a special 1-year warranty — see "Circuit Board Service Policy" on Page 2-45 for complete details.

To align this Transceiver, you should have a volt-ohmmeter with a high ohms-per-volt rating and a 50 ohm dummy load capable of dissipating 100 watts of power.

The following accessories are also available for use with this Transceiver:

- An accessory noise blanker that can be installed to reduce impulse type noise. A front panel switch is included for this accessory.
- A very versatile accessory VFO. This instrument includes a duplicate of the VFO in the Transceiver and a switching circuit which permits you to transceive with either the Transceiver or the accessory VFO, or to transmit on either VFO and to receive on the other. This instrument is particularly appealing to those operators who communicate with stations operating split-frequency.
- A narrow filter for CW operation. Space is provided for it on the carrier generator/XTAL filter circuit board.
- An AC-operated power supply, as well as a speaker in a matching cabinet. The power supply can be installed in the speaker cabinet.

Refer to the "Kit Builders Guide" for information on tools, wiring, soldering, resistors, and capacitors.



[The main body of the page contains extremely faint and illegible text, likely bleed-through from the reverse side of the paper.]

PARTS PACKAGING

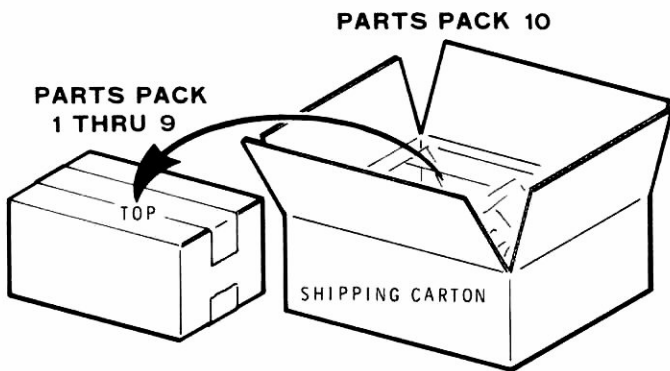

The Transceiver shipping carton contains a box marked "Packs 1-9 TOP." After you remove this box, the remaining parts in the shipping carton form Parts Pack #10, which are items too large to fit into the other parts packs, parts used for several circuit boards, and those items which you will use in the chassis assembly sections.

Open the "TOP" side of the box marked Packs 1-9. Under the cover you will find a "Pack Index Sheet" lying on top of

the contents. This sheet shows you the location of each parts pack in the box. DO NOT disturb any of these packs yet.

Each assembly section of the Manual contains its own Parts List and Step-by-Step Assembly instructions. At the beginning of each Parts List you will be told which parts pack to remove from the box and open. You may also be directed to remove certain required parts from pack #10.

To avoid intermixing parts, do not remove or open any of the parts packs until directed to do so at the beginning of one of the Parts Lists. Any part that is packed in an individual envelope with a part number on it should be placed back in its envelope after you identify it until that part is called for in a step. Some envelopes have one side transparent so the parts inside can be identified without opening the envelope.

In the shipping carton is a flattened cardboard carton marked with red. Save this carton. Its use is described in "Circuit Board Service Policy" on Page 2-45.



ASSEMBLY NOTES

The assembly of your transceiver is divided into two principal sections – the circuit boards and the chassis. The circuit boards and certain subassemblies will be built first, and then laid aside, so each one will be available when it is required for the chassis assembly.

A soldering iron rated at 15 to 25 watts is preferred. A 1/16" or 1/8" pyramidal or chisel tip is best. This type of soldering iron will make the kit easier to assemble and there will be less chance of solder bridges occurring between foils on the circuit board (when solder connects two foils unintentionally, it is called a solder "bridge"). Be sure to apply enough heat so the solder flows easily and has a shiny surface when it cools; however, an excessive amount of heat can sometimes cause the foil to separate from the circuit board, so be careful.

Use only the amount of solder required to make a good connection, as shown in the "Kit Builders Guide." The use of an excessive amount of solder does not improve the electrical connection, and you may run out of solder before you complete the assembly of your Transceiver. If you do run out of solder, be sure you buy only resin core solder; the use of acid core solder will void your warranty.

Notice the soldering abbreviations used in the steps. (NS) means not to solder because other wires will be added later. "S-" with a number, such as (S-3), means to solder the connection. The number following the "S" tells how many wires are at the connection. (Where a wire passes through a connection and goes on to another point, it counts as two wires.)

NOTE: Always use rosin core, radio-type solder (60:40 or 50:50 tin-lead content) for all of the soldering in this kit. This is the type we have supplied with the parts. The Warranty will be void and we will not service any kit in which acid core solder or paste has been used.

Resistors are designated by their color bands and their resistance in Ω (ohms), $k\Omega$ (kilohms), or $M\Omega$ (megohms). The resistor color code is explained in the "Kit Builders Guide." Capacitors are designated by their capacitance value and type.

Each part represented on the schematic diagrams has a component number which is composed of a letter followed by a number. These component numbers are used in the Parts Lists, the assembly steps, and in other parts of the Manual for parts identification. A specific group of numbers is assigned to each individual circuit board, such as 400 to 499 for the HFO circuit board. Thus, the first resistor on this board is numbered R401, the sixth capacitor is numbered C406, etc. Refer to the Schematic Notes for a list of the number groups.

Always tighten hardware when you install it unless you are instructed to leave it loose.

Each circuit part in this kit has its own component number (R2, C4, etc.). Use these numbers when you want to positively identify the same part in the various sections of the Manual. These numbers, which are especially useful if a part has to be replaced, appear:

- In the parts list,
- At the beginning of each step where a component is installed,
- In some illustrations,
- In the Schematic,
- In the sections at the rear of the Manual.

Some illustrations are too large for this Manual and will be found in the "Illustration Booklet." You will be directed to this Booklet when necessary. The illustrations are arranged in the order in which you will use them.



[The remainder of the page is blank with some faint, illegible ghosting of text from the reverse side.]

CIRCUIT BOARD ASSEMBLY

Before starting to assemble this kit, be sure you have read the wiring, soldering, and step-by-step assembly information in the "Kit Builders Guide."

Unless you are otherwise instructed, parts will be installed on the top side of each circuit board (the side with the component outlines), and the leads will be soldered to the foil (other) side. Solder the leads only to the foil side of the circuit board unless you are specifically instructed otherwise. Before you clip off the excess length of each lead (as illustrated in the "Kit Builders Guide"), look at the junction of the lead and the foil to make sure the lead has been soldered.

Take your time while assembling the circuit board — accuracy is far more important than speed. Position each component over its outline on the circuit board and solder each connection carefully, as improper soldering causes more difficulty than anything else. Be careful not to cover unused holes with solder or to form a solder "bridge" between two foils.

Most circuit boards are identified by their part number. These are listed in each Parts List and printed on the component side of each circuit board. When you have finished mounting the parts on a circuit board, set the board aside until it is called for later in the assembly instructions.

Use 1/2 watt 5% tolerance (fourth band gold) resistors unless directed otherwise in a step. The fourth band is silver for 10% tolerance resistors.

When you install a transistor on a circuit board, leave about 1/4" between the transistor body and the circuit board. The instructions will point out any exceptions.

Transistors are marked for identification in one of the following four ways:

1. Part number.
2. Type number.
3. Part number and type number.
4. Part number with a type number other than the one listed.

NOTES:

- Some parts, such as resistors and small electrolytic capacitors, may be mounted vertically. Some of the mounting details show the bodies of these devices elevated above the circuit board to clarify the routing of the leads.
- Before you solder, push each part (except transistors) down against the circuit board.
- Solder a part, or a group of parts, only when instructed to do so. Follow the instructions carefully and read the entire assembly step before you perform each operation.



VARIABLE FREQUENCY OSCILLATOR (VFO) AND EXTENDER BOARD

PARTS LIST

Remove the parts from Pack #1 and check each part against the following list. Make a check (✓) in the space provided as you identify each part. Any part that is packed in an individual envelope with the part number on it should be placed back in the envelope after you identify it until it is called for in a step. Do not throw away any packing materials until all parts are accounted for.

QTY.	DESCRIPTION	HEATH No.	CIRCUIT Component No.
RESISTORS, 1/2-Watt			
() 2	47 Ω (yellow-violet-black)	6-470	R1205, R1237
() 2	100 Ω (brown-black-brown)	6-101	R1226, R1228
() 1	150 Ω (brown-green-brown)	6-151	R1206
() 3	470 Ω (yellow-violet-brown)	6-471	R1203, R1233, R1236
() 1	1200 Ω (brown-red-red)	6-122	R1201
() 2	3300 Ω (orange-orange-red)	6-332	R1231, R1234
() 1	3900 Ω (orange-white-red)	6-392	R1227

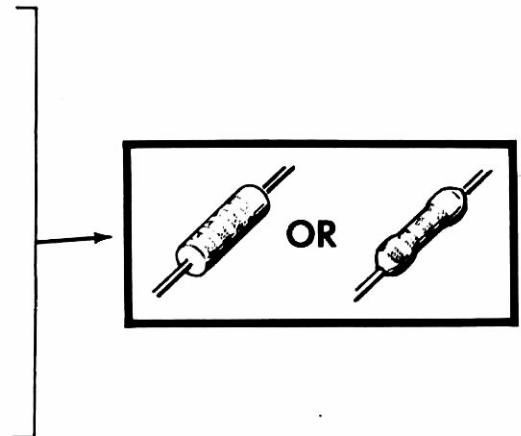

QTY.	DESCRIPTION	HEATH No.	CIRCUIT Component No.
Resistors (cont'd.)			
() 2	22 kΩ (red-red-orange)	6-223	R1229, R1235
() 1	220 kΩ (red-red-yellow)	6-224	R1225
() 1	1 MΩ (brown-black-green)	6-105	R1204
() 1	2000 Ω control	10-398	R1232

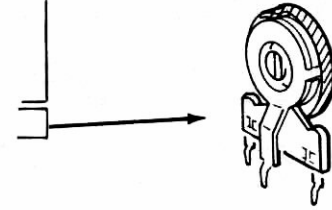
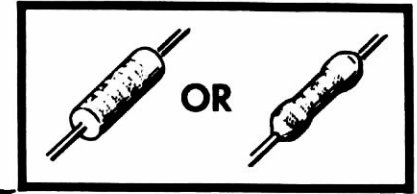

CAPACITORS

Mica

() 1	12 pF	20-130	C1209
() 1	400 pF	20-116	C1233
() 2	470 pF	20-128	C1229, C1231
() 1	680 pF	20-107	C1234

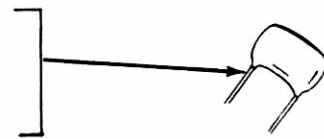

Disc

() 1	6 pF, N470	21-169	C1202
() 1	10 pF	21-3	C1214
() 1	15 pF, NPO	21-111	C1216
() 1	50 pF, N150	21-190	C1203
() 1	56 pF, N75	21-160	C1204
() 1	470 pF	21-56	C1227
() 2	510 pF, N750	21-159	C1205, C1206
() 1	510 pF, N1500	21-191	C1207
() 1	.001 μF	21-140	C1225
() 1	.005 μF	21-27	C1208
() 5	.01 μF	21-47	C1213, C1215, C1226, C1228, C1232

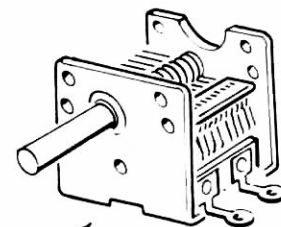
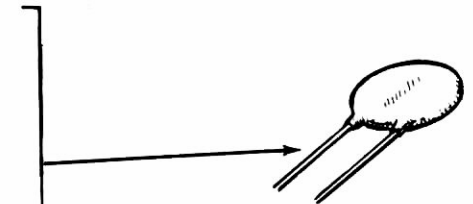

Other Capacitors

() 1	Tuning capacitor	26-148	C1201
() 1	15-60 pF trimmer	31-63	C1211
() 1	4.7 pF ceramic	21-29	C1212

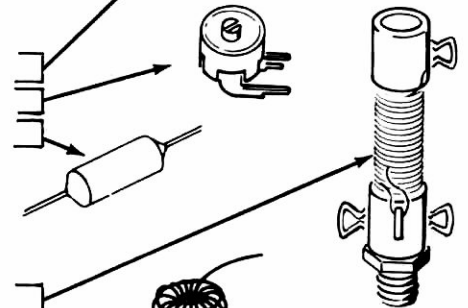

INDUCTORS

() 1	Variable inductor	40-1720	L1201
() 2	Toroid coil	40-1684	L1202, L1203
() 2	RF choke	45-82	RFC1201, RFC1202

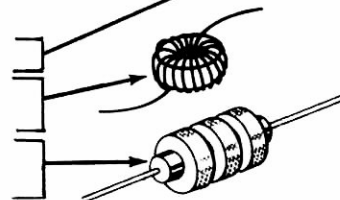

QTY.	DESCRIPTION	HEATH No.	CIRCUIT Component No.
------	-------------	-----------	-----------------------

DIODES-TRANSISTORS

()	1	1N458 diode	56-24	D1201
()	3	1N4149 diode	56-56	D1202, D1203, D1204
()	1	VR7.5 zener diode	56-97	ZD1201

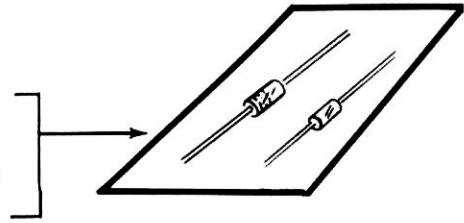

NOTE: Transistors may be marked in any of the following four ways.

1. Part number.
2. Type number.
3. Part number and type number.
4. Part number and a type number other than the one listed.

()	1	2N3393 transistor	417-118	Q1204
()	2	MPF105 transistor	417-169	Q1202, Q1203
()	1	2N3638A transistor	417-234	Q1205

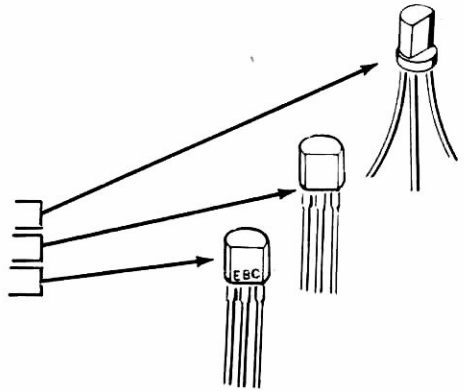
METAL PARTS

()	1	VFO chassis	206-1104
()	1	VFO shield	206-1168
()	1	VFO bracket	204-1962

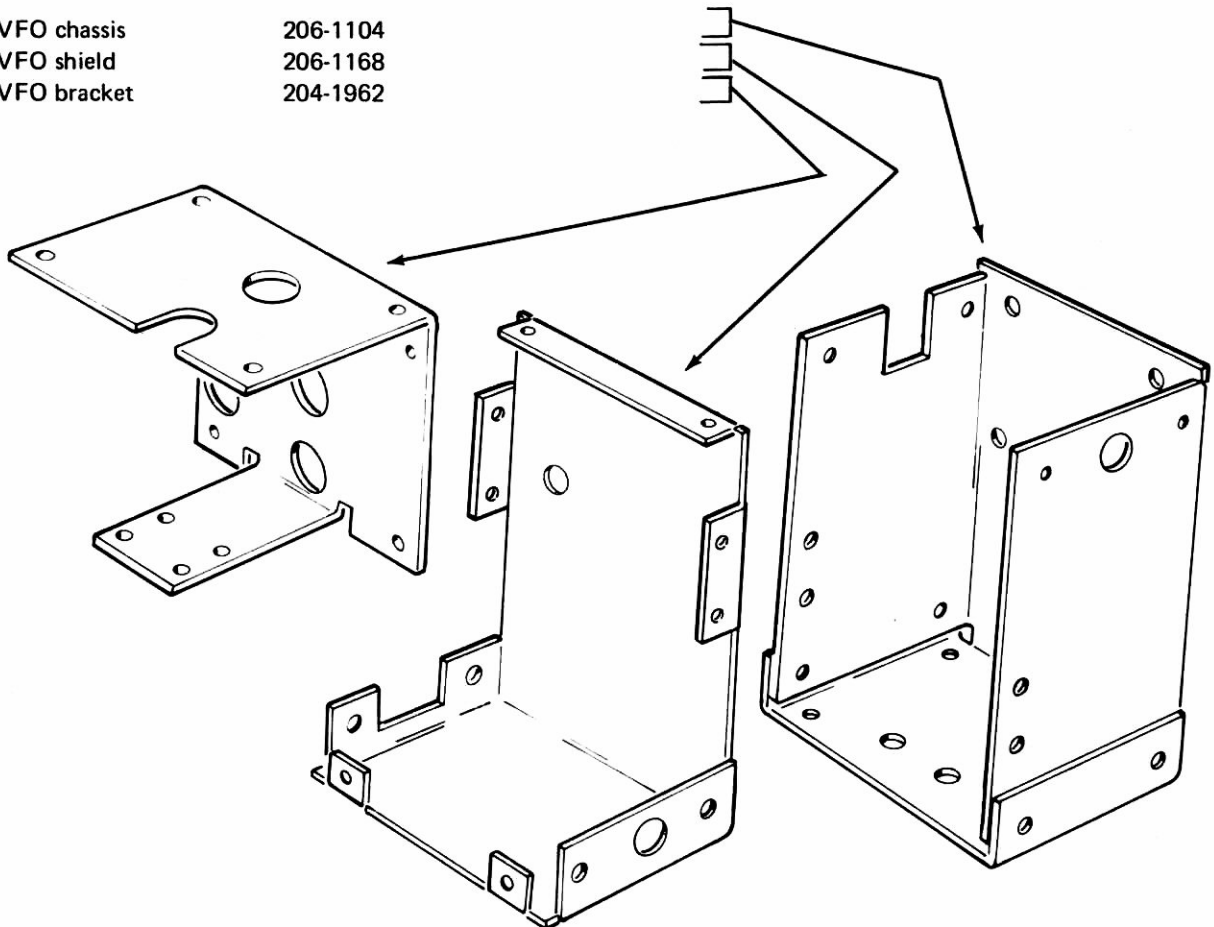

QTY.	DESCRIPTION	HEATH No.	CIRCUIT Component No.
------	-------------	-----------	-----------------------

HARDWARE

#4 Hardware

()	4	4-40 x 5/8" screw	250-323
()	4	4-40 nut	252-15
()	4	#4 lockwasher	254-9

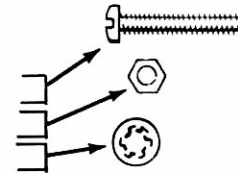

#6 Hardware

()	4	6-32 x 3/16" screw	250-138
()	2	6-32 x 1/4" screw	250-56
()	18	#6 x 3/8" sheet metal screw	250-475
()	2	6-32 x 1/2" flat head screw	250-11
()	4	#6 lockwasher	254-1
()	2	#6 solder lug	259-1
()	2	#6 plain solder lug	259-6

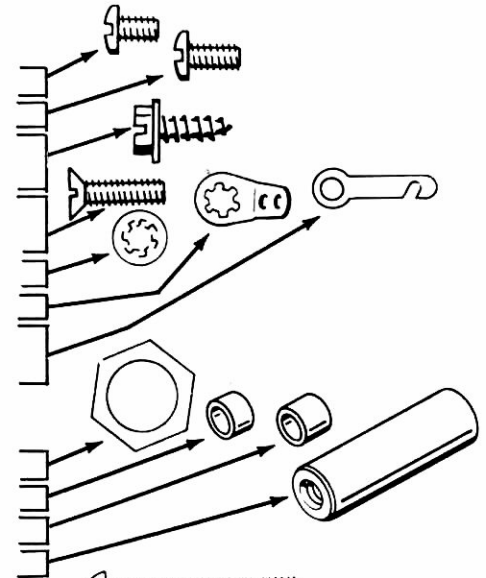

Other Hardware

()	1	Control nut	252-7
()	8	1/8" spacer	255-1
()	2	3/16" spacer	255-2
()	2	7/8" spacer	255-21

Drive Attaching Hardware

()	2	6-32 x 1" screw	250-13
()	4	#6 flat washer	253-60
()	2	7/16" spacer	255-102
()	1	Spring washer	253-36

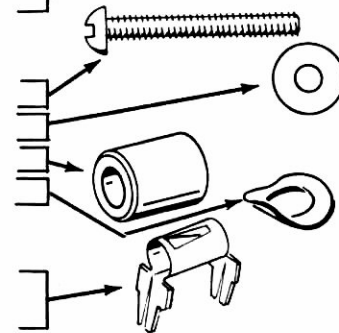

CONNECTORS

()	48	Circuit board connector	432-124
-----	----	-------------------------	---------



()	4	Female terminal	432-855
-----	---	-----------------	---------

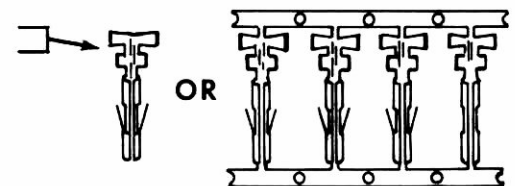

()	1	Male connector housing	432-817
-----	---	------------------------	---------

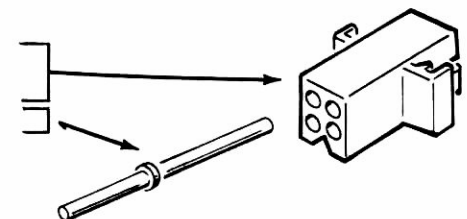

()	24	Extender pin	262-24
-----	----	--------------	--------

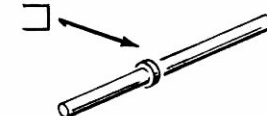

QTY.	DESCRIPTION	HEATH No.	CIRCUIT Component No.
MISCELLANEOUS			
() 1	Vernier drive (long shaft)	100-1608	
() 1	Vernier drive (short shaft)	100-1041	
() 2	Fish paper	75-90	
() 1	Heat sink	215-63	
() 1	Cement (tube)	350-12	
() 2	Board puller	207-80	
() 4	Extender block	255-108	
() 1	Nut starter	490-5	

PARTS FROM PACK #10 (parts in the shipping carton)

() 1	Oscillator circuit board	85-1205-7
() 1	Buffer circuit board	85-1206-3
() 1	Extender board	85-1465

NOTE: Remove the wire bundle. Cut off lengths when you are directed to do so by the assembly steps in the various sections of the Manual. Use solid wire in steps unless otherwise specified.

Wire bundle consisting of:

() 13'-8 1/2"	Small bare wire	340-2
() 1'	Large bare wire	340-3
() 12'-4 1/4"	Shielded cable	343-15
() 2'	Large orange wire	344-30
() 9'	Red wire	344-52
() 5'	Small orange wire	344-53
() 28 1/2'	Gray wire	344-58
() 1'	Blue wire	344-96
() 5'	Stranded white wire	344-109
() 3-1/2"	RG-58A/U coaxial cable	343-2
() 6"	Fiber sleeving	346-4
() 1'	Small sleeving	346-1
() 1'	Large sleeving (heat shrinkable)	346-20
()	Solder	

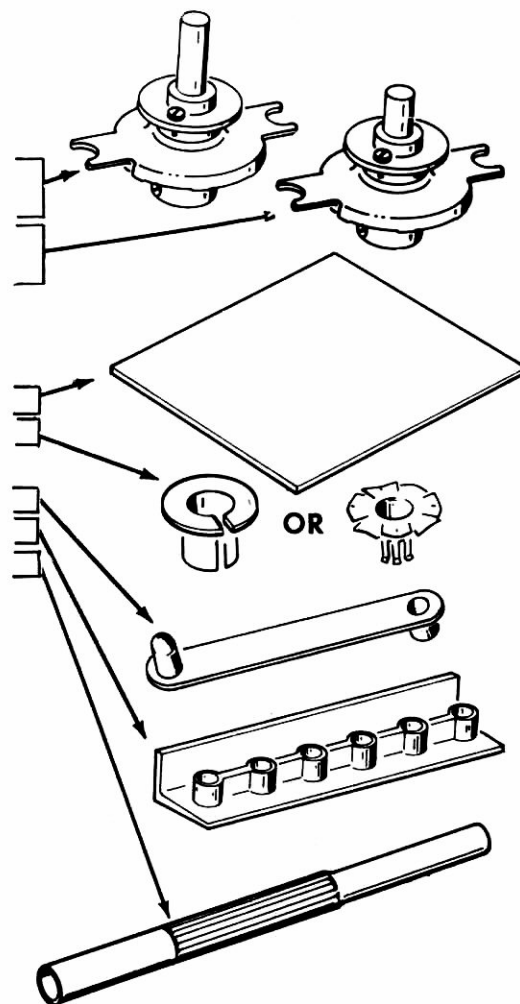



QTY.	DESCRIPTION	HEATH No.	CIRCUIT Component No.
------	-------------	-----------	-----------------------

Parts From Pack #10 (cont'd.)

()	1	Terminal identification label	390-1045
()	1	Call letters label	390-1087

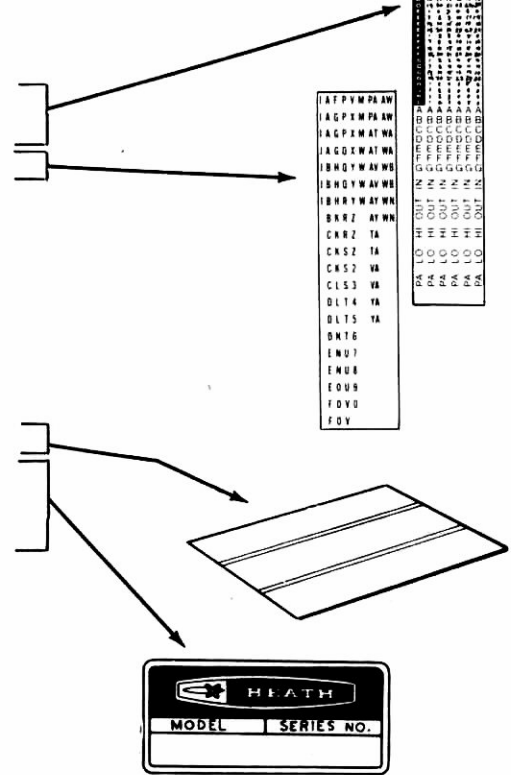

()	1	Black strips label	390-1090
()	1	Blue and white identification label – See note below.	
()	1	Parts Order Form	597-260
()	1	Kit Builders Guide	597-308
()	1	Assembly Manual (See Page 1-1 for part number.)	
()	1	Operation and maintenance Manual (See Page 2-1 for part number.)	

LABEL NOTE: Find the blue and white label in your kit. Now copy the numbers from it onto the space provided in the illustration above. Refer to these numbers in any communication you have with the Heath Company about this kit.

To order a replacement part, always include the **PART NUMBER**. Use the Parts Order Form furnished with this kit. If one is not available, see "Replacement Parts" inside the rear cover of this Manual. Your Warranty is located inside the front cover. For pricing information, refer to the separate "Heath Parts Price List."

STEP-BY-STEP ASSEMBLY

EXTENDER CIRCUIT BOARD

START

Place the extender board (#85-1465) foil side down.

Install each circuit board connector in the following manner. Note that inside each connector the spring contact is depressed on one end. This depressed end of the connector must face away from the edge of the circuit board. Insert the mounting tabs through the circuit board until the ridges of the connector are firmly against the foil. Solder the tabs to the foil.

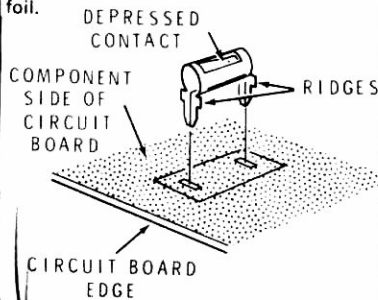

- () Six circuit board connectors.
- () Six circuit board connectors.
- () Six circuit board connectors.
- () Six circuit board connectors.
- () Six circuit board connectors.
- () Six circuit board connectors.
- () Six circuit board connectors.
- () Six circuit board connectors.

() Look at the connector row to be sure the depressed end of the contact of each connector is toward the center of the circuit board.

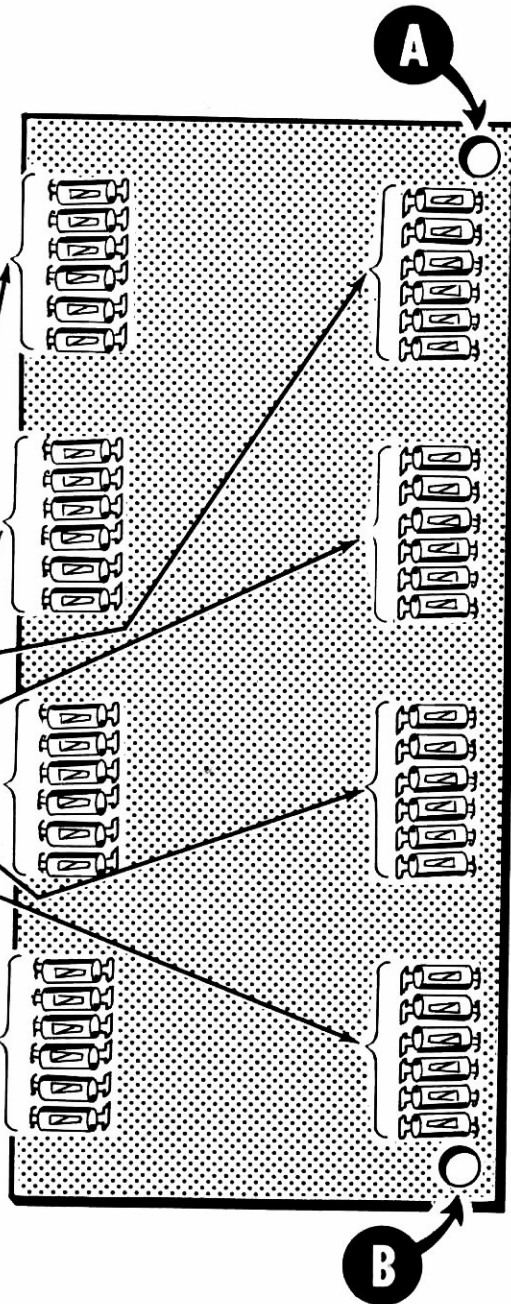

CONTINUE

Mount board pullers on the foil side of the circuit board at holes A and B. Position the female part in the circuit board hole; then push the male part through the female part to the top of the board.

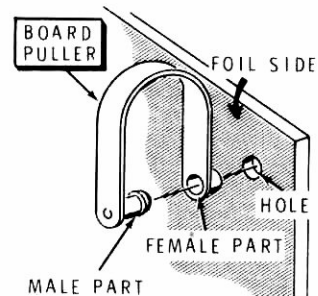

Circuit Board Checkout

It is important that you perform the checkout procedure after each circuit board is completed.

Carefully inspect the foil of the circuit board for the following most commonly made errors. Consult your "Kit Builders Guide" to remedy these problems if any exist.

- () Unsoldered connections.
- () "Cold" solder connections.
- () Solder bridges between foil patterns.

PICTORIAL 1-1

EXTENDER BLOCK

Refer to Pictorial 1-2 for the following steps.

- (1) Find the four extender blocks and the twenty-four extender pins.
- (2) Position an extender block as shown. Then refer to Detail 1-2A and insert the long end of an extender pin into the block. Push the pin into the block until the ridge is against the block. The pins are a tight fit. A small hammer may be helpful.
- (3) Install an extender pin in each of the five remaining holes in the extender block.
- (4) Install extender pins in the remaining three extender blocks.
- (5) Plug the four extender blocks into the circuit board connectors on the edge of the extender board which has the board pullers.
- (6) Set the extender board aside. It will be used later.

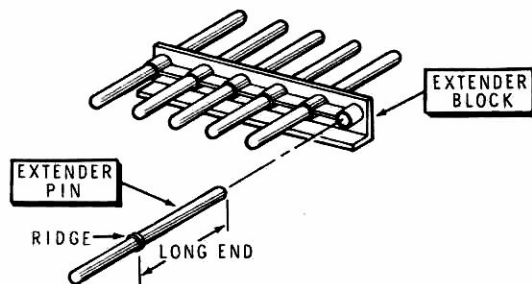

Detail 1-2A

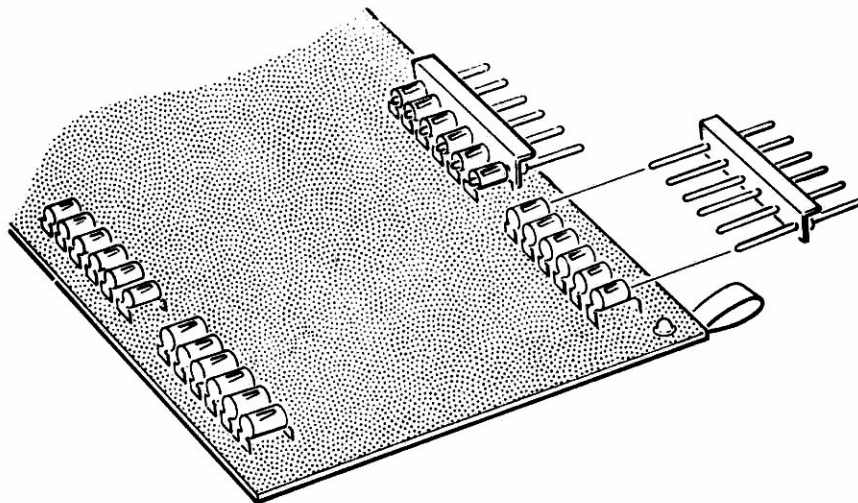

PICTORIAL 1-2

OSCILLATOR CIRCUIT BOARD

START

Position the oscillator circuit board (#85-1205-7) as shown. Then complete each step in the order listed.

() R1206: 150 Ω (brown-green-brown).

() R1205: 47 Ω (yellow-violet-black)

() RFC1202: 350 μH choke (#45-82). Bend the leads toward the slot in the choke body to avoid placing any strain on the leads of the choke winding. Then install the choke as shown.



() C1212: 4.7 pF ceramic. (May be marked 4.7 MMF.)

() R1201: 1200 Ω (brown-red-red).

() Wrap the leads of a 1N4149 diode (#56-56) around both leads of the 1 MΩ (brown-black-green) resistor as shown. Solder the leads together at the indicated locations.

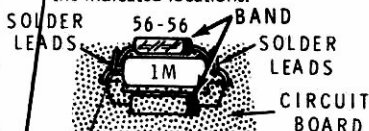

() R1204, D1204: 1 MΩ 1N4149 resistor-diode assembly. Position the banded end of the diode as shown.

() R1203: 470 Ω (yellow-violet-brown).

FOR GOOD SOLDER CONNECTIONS, YOU MUST KEEP THE SOLDERING IRON TIP CLEAN.

WIPE IT OFTEN WITH A DAMP SPONGE OR CLOTH



SAFETY WARNING: Avoid eye injury when you clip off excess lead lengths. We suggest you wear glasses, or at least clip the leads so the ends will not fly toward your eyes.

() Solder the leads to the foil and cut off the excess lead lengths.

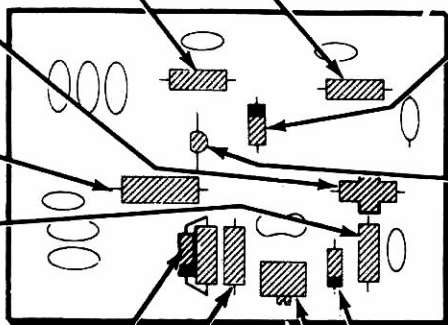

CONTINUE

NOTE: When you install a diode, always match the band on the diode with the band mark on the circuit board.



() ZD1201: VR7.5 zener diode (#56-97).

() Q1202: MPF105 transistor (#417-169). Line up the flat of the transistor with the outline of the flat on the circuit board. Then insert the leads into their correct D, S, and G holes. Solder the leads to the foil and cut off the excess lead lengths.

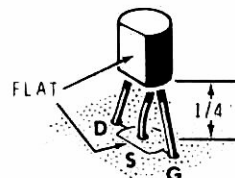

NOTE: When you install a diode, always match the band on the diode with the band mark on the circuit board.

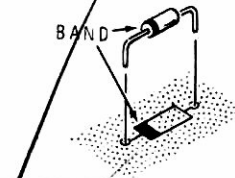

() D1201: 1N458 diode (#56-24).

() C1211: 15-60 pF trimmer.



() Solder the leads to the foil and cut off the excess lead lengths.

PICTORIAL 1-3

START

NOTE: When you install disc capacitors, do not push the insulated portion of the leads into the circuit board holes. This could make it difficult to solder the leads to the foil.

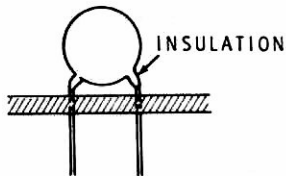

- () C1207: 510 pF (N1500) disc. Be sure this is the N1500 capacitor.
- () C1206: 510 pF (N750) disc.
- () C1205: 510 pF (N750) disc.
- () C1216: 15 pF disc.
- () C1202: 6 pF disc.
- () C1203: 50 pF disc.
- () C1204: 56 pF disc.
- () Solder the leads to the foil and cut off the excess lead lengths.

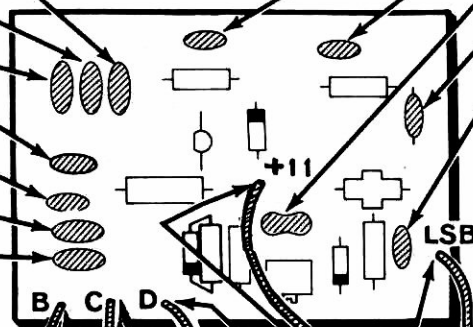

CONTINUE

- () C1214: 10 pF disc.
- () C1213: .01 μ F disc.
- () C1209: 12 pF mica.
- () C1215: .01 μ F disc.
- () C1208: .005 μ F disc.
- () Solder the leads to the foil and cut off the excess lead lengths.
- NOTES:
 1. Cut the following wires to the proper lengths and remove 1/4" of insulation from each end unless directed otherwise in a step. Then solder each wire as it is connected and cut off the excess lead length.
 - Only one end of each wire will be connected at this time.
 - () Connect a 6" small orange wire to hole LSB.
 - () Connect a 5" red wire to hole +11.
 - () Connect a 2" small orange wire to hole D.
 - () Connect a 1-3/4" gray wire to hole C.
 - () Cut a 3-3/8" red wire. Then remove 1/4" of insulation from one end and 1-1/8" of insulation from the other end.
 - () Connect the 1/4" bare end of the red wire to hole B.

PICTORIAL 1-4

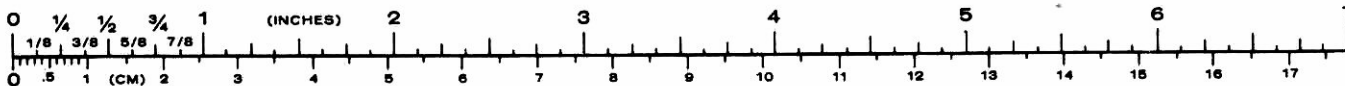

CIRCUIT BOARD CHECKOUT

- Carefully inspect the circuit board for the following conditions.
- Unsoldered connections.
 - "Cold" solder connections.
 - Solder bridges between foil patterns.
 - Protruding leads. No lead should be longer than 1/8".
 - Transistors for the proper type and installation.
 - Diodes for the correct position of the banded end.

BUFFER CIRCUIT BOARD

CONTINUE

START

- Position the buffer circuit board (#85-1206-3) as shown.
- () R1231: 3300 Ω (orange-orange-red).
- () R1227: 3900 Ω (orange-white-red).
- () R1229: 22 k Ω (red-red-orange).
- () R1226: 100 Ω (brown-black-brown).
- () R1228: 100 Ω (brown-black-brown).
- () R1233: 470 Ω (yellow-violet-brown).
- () R1235: 22 k Ω (red-red-orange).
- () R1236: 470 Ω (yellow-violet-brown).
- () Solder all leads to the foil and cut off the excess lead lengths.

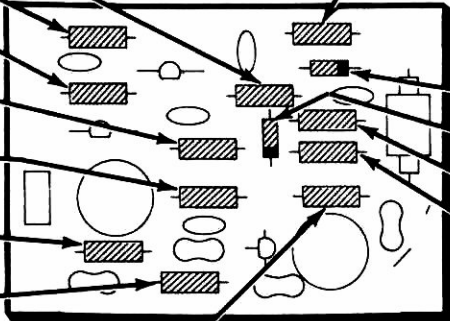

- () R1225: 220 k Ω (red-red-yellow).
- NOTE: When you install a diode, always match the band on the diode with the band mark on the circuit board.
- () D1202: 1N4149 diode (#56-56).
- () D1203: 1N4149 diode (#56-56).
- () R1234: 3300 Ω (orange-orange-red).
- () R1237: 47 Ω (yellow-violet-black-gold).
- NOTE: In the following step, save two cutoff resistor leads for use later.
- () Solder all leads to the foil and cut off the excess lead lengths.

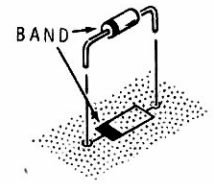

PICTORIAL 1-6

START

✓) Q1203: MPF105 transistor (#417-169). Line up the flat of the transistor with the outline of the flat on the circuit board. Then insert the leads into their correct D, S, and G holes. Solder the leads to the foil and cut off the excess lead lengths.

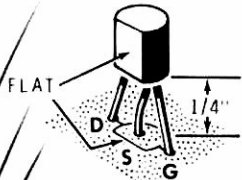

() C1226: .01 μ F disc.

() C1227: 470 pF disc.

() Q1204: 2N3393 transistor (#417-118). The transistor may be one of the two types shown below. Insert the transistor leads into the corresponding E, C, and B holes in the circuit board as shown. Solder the leads to the foil and cut off the excess lead lengths.

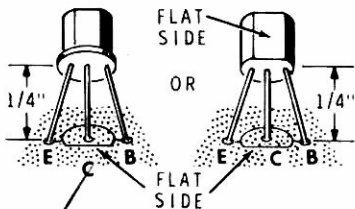

() L1202: 3.7 μ H toroid coil (#40-1684). Insert the leads in the holes and then bend the coil over as shown. Solder the leads to the foil and cut off the excess lead lengths.

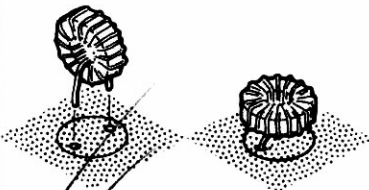

() C1231: 470 pF mica.

() C1229: 470 pF mica.

() Solder the leads to the foil and cut off the excess lead lengths.

CONTINUE

() C1225: .001 μ F disc.

() C1228: .01 μ F disc.

() C1232: .01 μ F disc.

() RFC1201: 350 μ H choke (#45-82). Bend the leads toward the slot in the choke body to avoid placing any strain on the leads of the choke winding. Then install the choke as shown.

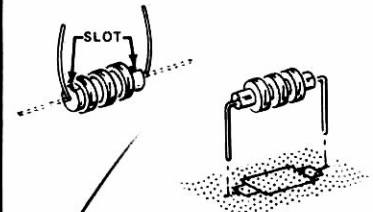

() C1234: 680 pF mica.

() L1203: 3.7 μ H toroid coil (#40-1684).

() C1233: 400 pF mica.

() Solder the leads to the foil and cut off the excess lead lengths.

() Push a heat sink onto a 2N3638A transistor (#417-234). The bottom of the heat sink must not project below the transistor body or its leads might be shorted.



() Q1205: 2N3638A transistor (#417-234). Identify the leads from the drawing below. Then insert the leads into the indicated circuit board holes as shown. Solder the leads to the foil and cut off the excess lead lengths.

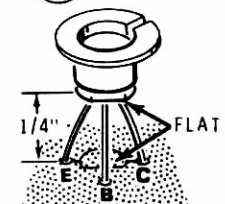

PICTORIAL 1-7

OSCILLATOR CIRCUIT BOARD

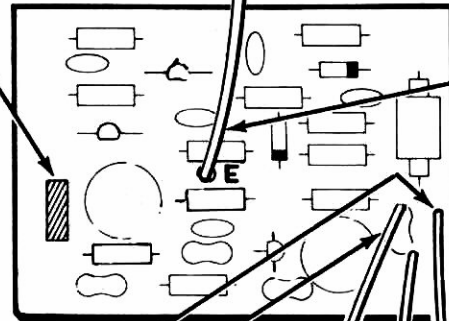
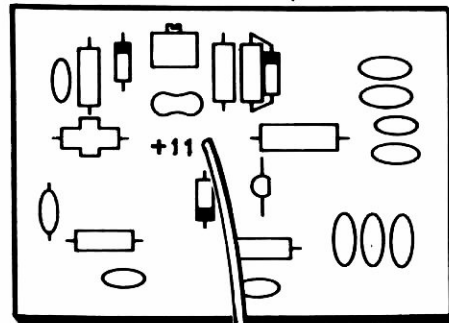

START

(1) R1232: 2000 Ω , variable. Solder the leads of the control when you install it. Be sure the control is pushed down tight against the circuit board and that the leads on the control extend through the circuit board holes before you solder the pins to the foil.



NOTES:

1. Cut the following wires to the proper lengths and remove 1/4" of insulation from each end. Solder each wire as it is connected and cut off the excess lead lengths.

2. Only one end of each wire will be connected at this time.

(2) 1-1/2" small bare wire to GND.

(3) 1-3/4" red wire to +11.

(4) 1-3/4" gray wire to OUTPUT.

5" RED

CONTINUE

(5) Position the oscillator circuit board near the buffer circuit board as shown.

(6) Connect the free end of the red wire coming from +11 on the oscillator circuit board, to hole E on the buffer circuit board.

CIRCUIT BOARD CHECKOUT

Carefully inspect the circuit board for the following conditions.

- (7) Unsoldered connections.
- (8) "Cold" solder connections.
- (9) Solder bridges between foil patterns.
- (10) Transistors for the proper type and installation.
- (11) Diodes for the correct position of the banded end.

FINISH

PICTORIAL 1-8

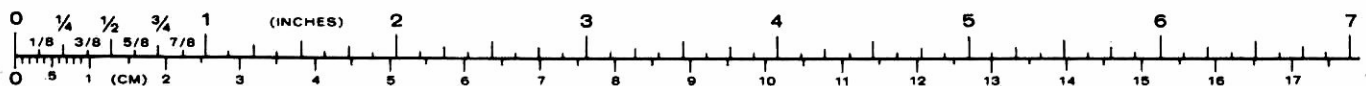

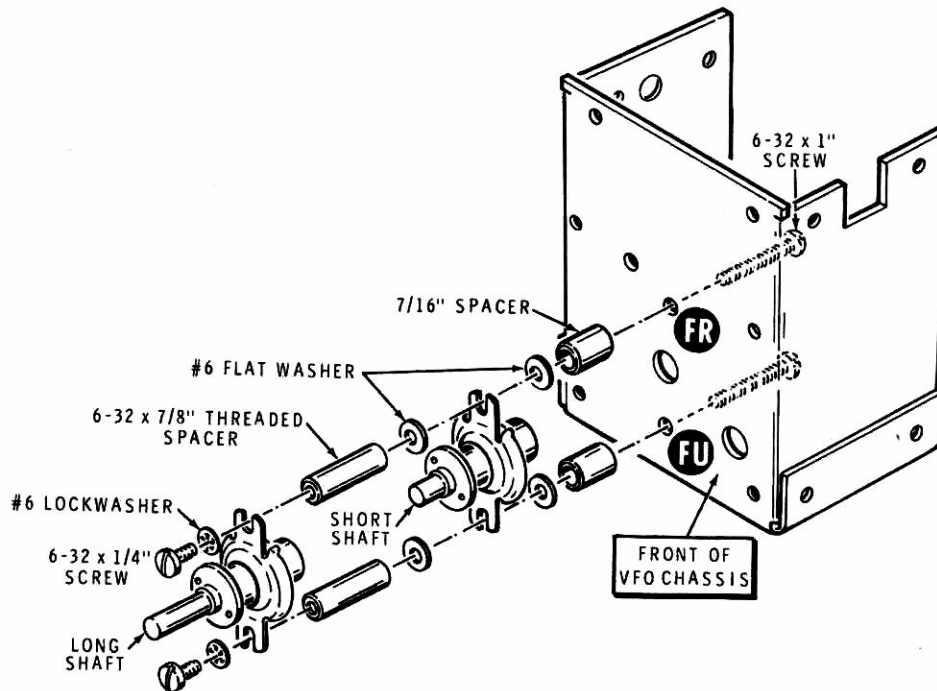

PICTORIAL 1-9

VFO ENCLOSURE

Refer to Pictorial 1-9 for the following steps.

- () Refer to Detail 1-9A and remove and discard the two brass screws in the collar of each of the two vernier drives.

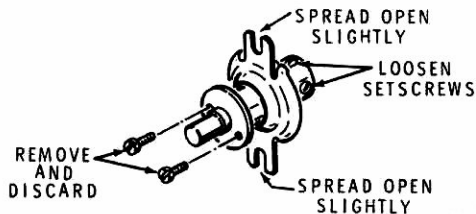

Detail 1-9A

- () Refer to Detail 1-9A and use a pair of long-nosed pliers to spread the mounting tabs on each vernier out slightly.
- () Loosen the two setscrews in the bushing of each vernier drive just enough to allow a 1/4" shaft to be inserted into the bushing.
- () Refer to Pictorial 1-9 and mount the short shaft vernier drive on the front of the VFO chassis at FR and FU. Use two 6-32 x 1" screws, two 7/16" spacers, four #6 flat washers, and two 6-32 x 7/8" tapped spacers as shown. Securely tighten the hardware.
- () Mount the long shaft vernier drive on the 6-32 x 7/8" threaded spacers with two 6-32 x 1/4" screws and two #6 lockwashers. Then tighten the setscrews in the bushing of the long shaft vernier drive onto the shaft of the other vernier drive.

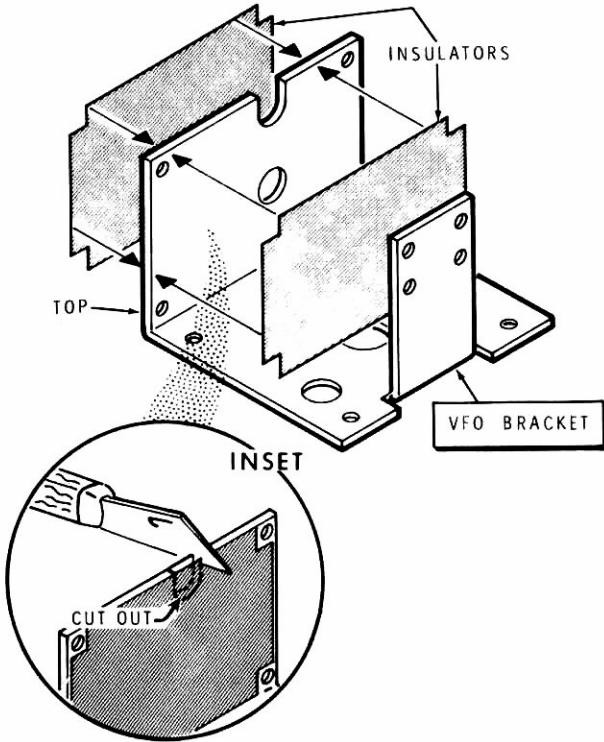

PICTORIAL 1-10

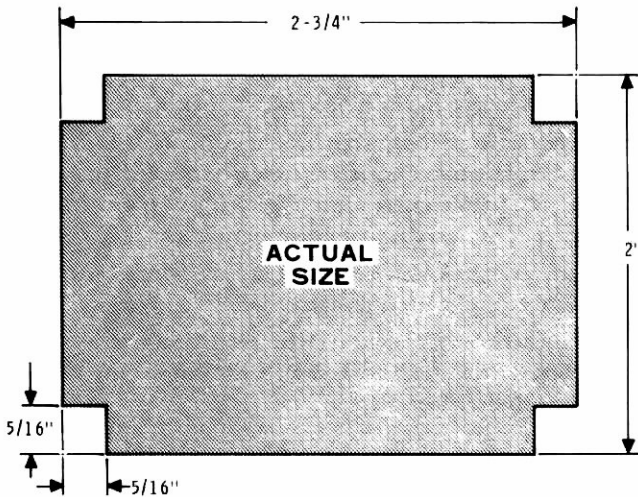

Detail 1-10A

Refer to Pictorial 1-10 for the following steps.

- () Refer to Detail 1-10A and prepare two insulators from two pieces of fish paper. **Save the remaining fish paper for use later.**
- () Remove the backing paper from one of the prepared insulators and install it on the top surface of the VFO mounting bracket.
- () Refer to the inset drawing of Pictorial 1-10 and use a small, sharp, cutting tool to remove the paper from the opening at the top of the bracket.
- () Remove the backing paper from the other insulator and install it on the bottom surface of the VFO mounting bracket. Then cut out the paper from the opening at the top of the bracket.

Refer to Pictorial 1-11 (Illustration Booklet, Page 1) for the following steps.

NOTES:

1. When hardware is called for in a step, only the screw size will be given. For instance, if "6-32 x 3/8" hardware" is called for, it means that a 6-32 x 3/8" screw, one or more #6 lockwashers, and a 6-32 nut should be used for each mounting hole. The Detail referred to in the step will show the proper number of lockwashers to use.
 2. The circuit boards must be positioned so the red wire between the two boards is positioned as shown.
- () Refer to Detail 1-11A and mount the oscillator circuit board and the buffer circuit board on the VFO mounting bracket. Use 4-40 x 5/8" hardware and two 1/8" spacers at each corner, with #6 plain solder lugs (#259-6) under the heads of the screws at holes FM and FW. Form and position the solder lugs as shown in the Pictorial. (Use the plastic nut starter to hold and start 4-40 and 6-32 nuts on screws.)



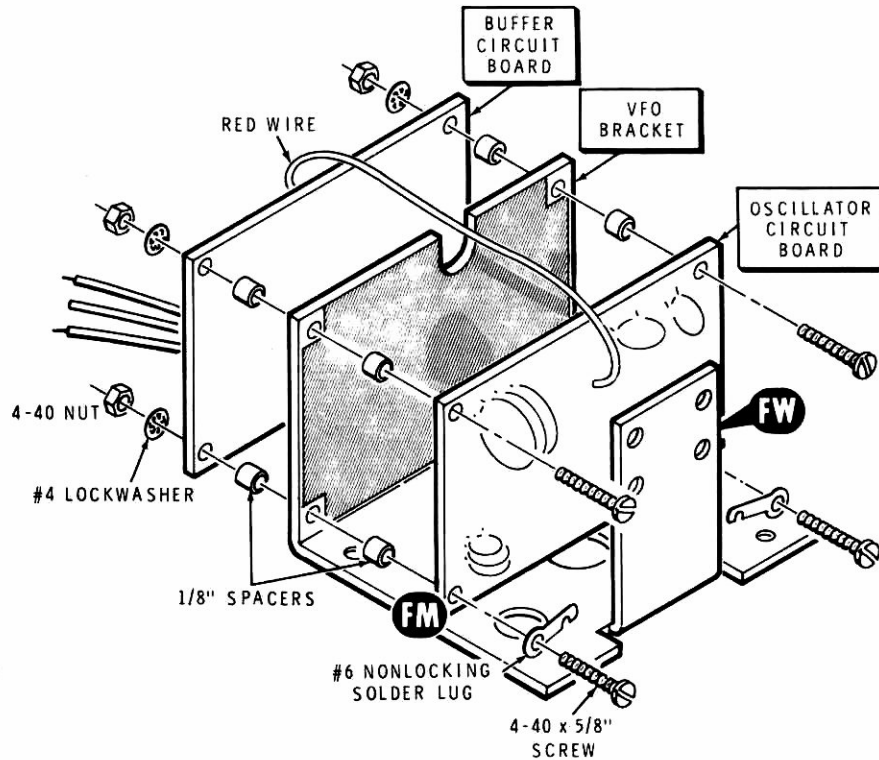

Detail 1-11A

Refer to Detail 1-11B, Part 1, and mount two #6 solder lugs on the front of the variable capacitor frame with 6-32 x 3/16" screws. Position the lugs at 45 degrees as shown. Keep the capacitor plates fully meshed with each other to avoid damage while handling.

C1201: Refer to Part 2 of Detail 1-11B and insert the shaft of the variable capacitor through hole C1201 in the mounting bracket. Then mount the variable capacitor on the VFO mounting bracket with 6-32 x 3/16" hardware. NOTE: Be sure you use the front holes in the bottom of the capacitor and the two front holes in the VFO mounting bracket as shown.

Refer to the Detail and bend one lug of the capacitor out of the way as shown.

Refer to Pictorial 1-11 and connect a 1-1/2" small bare wire from each solder lug on the front of the variable capacitor to corresponding solder lugs FM and FW on the circuit board mounting screws. Solder the two wires to the four solder lugs and cut off any excess wire lengths.

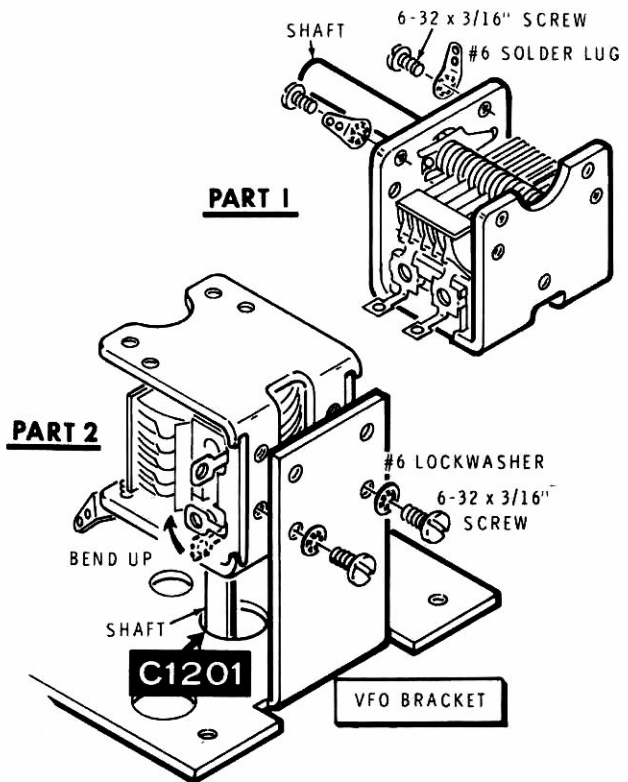

Detail 1-11B

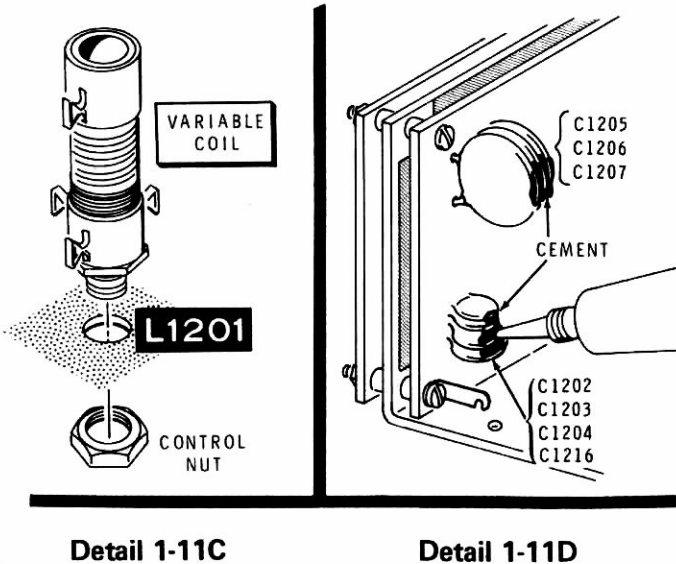

() L1201: Refer to Detail 1-11C and temporarily mount the VFO coil in hole L1201 in the VFO mounting bracket. Use a control nut. Position the coil as shown in the Pictorial.

Refer to Pictorial 1-11 and connect the wires coming from the oscillator circuit board as follows. Remove all slack from the wires but do not strain the connections.

NOTE: In the following steps, the letter "S" with a number such as (S-1) means to solder the connection. The number following the "S" tells how many wires are at the connection. If (NS) is used in a step, it means not to solder because other wires will be added later.

- () Gray wire to coil L1201 lug 2 (S-1).
- () Short orange wire to coil L1201 lug 1 (S-1).

NOTE: Where a wire passes through a connection and then goes to another point, as in the next step, it will count as two wires in the solder instructions (S-2), one entering and one leaving the connection. Be especially careful when you solder these connections that you apply enough solder and heat to properly solder these "through wires."

- () Red wire through coil L1201 lug 4 (S-2) to capacitor C1201 lug 2 (S-1).

NOTE: There is no connection to lug 3.

The long orange wire will be connected later.

() Refer to Detail 1-11D and press the top edges of disc capacitors C1205, C1207, and C1206 together. In a similar manner, press disc capacitors C1202, C1203, C1204, and C1216 together.

() Remove the cap from the tube of cement (#350-12) and, using a suitable small pointed tool, punch a hole in the end of the tube nozzle. CAUTION: This cement is very soft and sticky; handle it with care.

() Squeeze a sufficient amount of cement on the top edges of the two groups of disc capacitors to cement the capacitors together. Take care not to move these capacitors during the following steps as it will require several hours for the cement to set.

() Squeeze a few drops of cement into the centers of the two toroid coils on the buffer circuit board so the coils will be fixed in position on the board. NOTE: Save the remaining cement for use later.

Refer to Pictorial 1-12 (Illustration Booklet, Page 1) for the following steps.

() Position the orange wire out of the way toward the back of the VFO and the red, gray, and bare wires straight up from the buffer circuit board. Then remove the nut that secures coil L1201 to the VFO bracket.

() Refer to Detail 1-12A and carefully install the VFO bracket assembly into the VFO chassis. The variable capacitor shaft should pass through hole C1201 in the shield, through the spring washer, and into the bushing of the rear vernier drive. The concave side of the washer should be toward the VFO chassis as shown. The threaded coil bushing should pass through hole L1201.

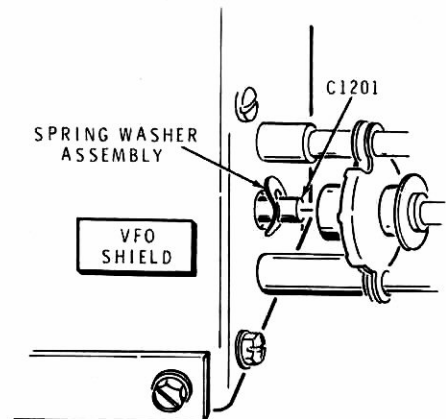

Detail 1-12A

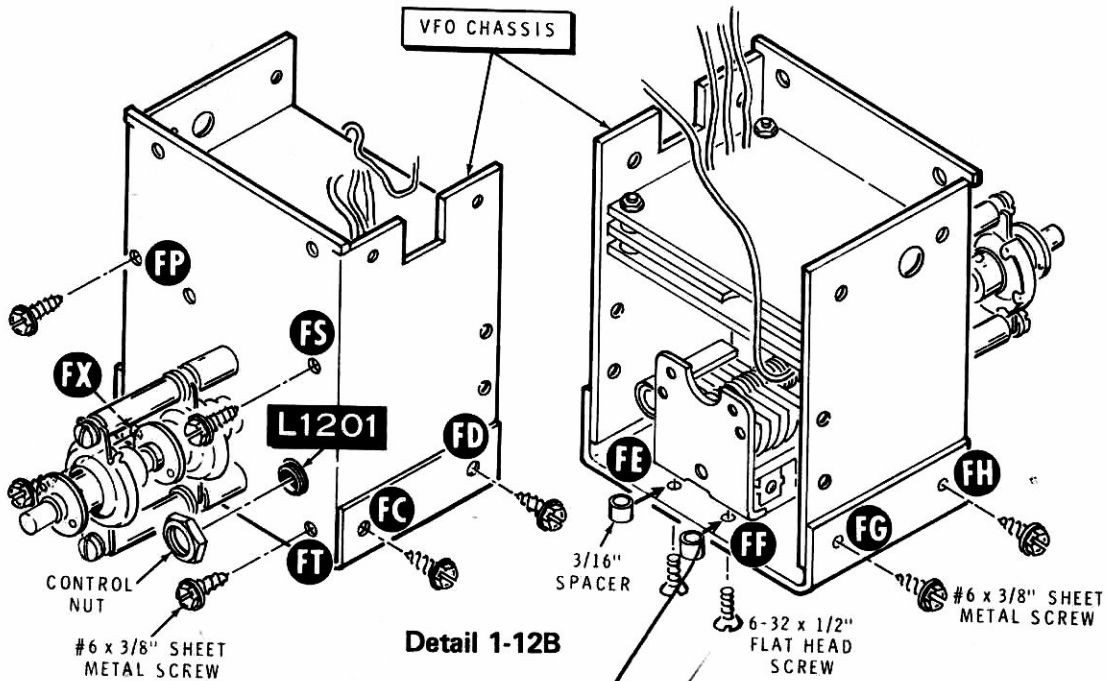

- () Refer to Detail 1-12B and, from the front of the shield, start #6 x 3/8" sheet metal screws into holes FP, FS, FT, FX, FC, FD, FH, and FG. Do not tighten the screws yet.
- () Secure the lower part of the VFO bracket and variable capacitor to the bottom of the VFO shield at FE and FF. Use a 6-32 x 1/2" flat head screw and a 3/16" spacer at each hole. NOTE: The spacers should be between the VFO shield and the bottom of the VFO mounting bracket.
- () Tighten the eight previously started #6 x 3/8" sheet metal screws.
- () Tighten the vernier drive setscrews onto the variable capacitor shaft.

- () Secure the bushing of coil L1201 on the front of the VFO with the nut you previously removed.
- () Refer to Detail 1-12C and cut the two supporting bands from the strip of four female terminals.

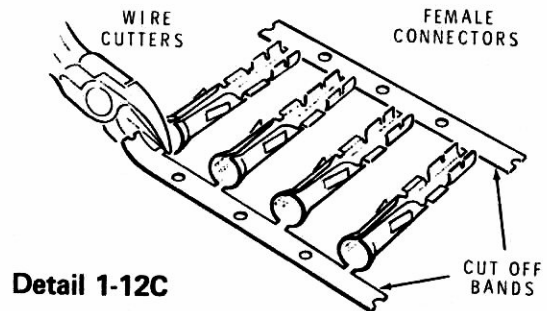

Detail 1-12C

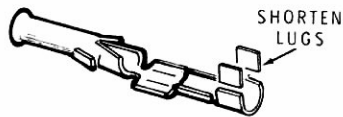

PART 1

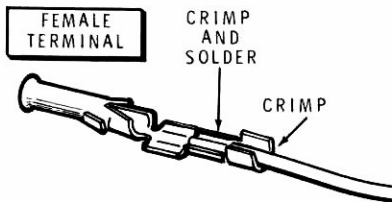

PART 2

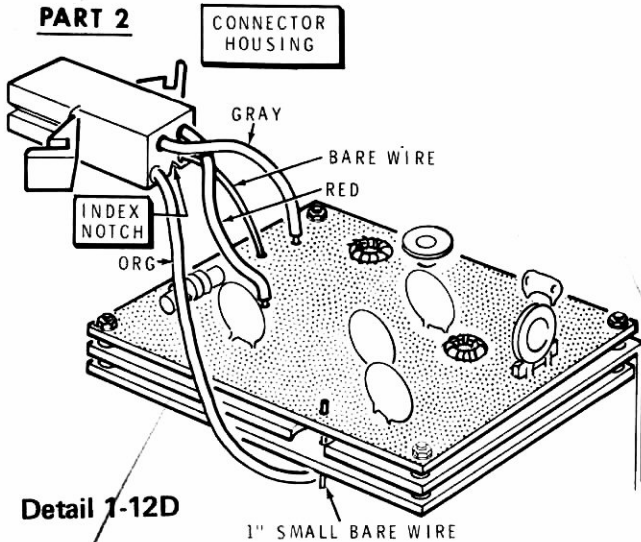

Detail 1-12D

Refer to Detail 1-12D for the next two steps.

- () Refer to Part 1 of Detail 1-12D and install female terminals on the free end of the bare wire and on the free ends of the orange, gray, and red wires coming from the VFO.
- () Position the male connector housing with the ears and index notch as shown; then refer to Part 2 of Detail 1-12D and insert the female terminals into the holes in the connector housing. Push each connector into the housing until it snaps into place. Select the hole for each wire according to its position relative to the index notch. Be sure to use the correct hole, as the connectors cannot be removed after they are inserted. Tug gently on each wire to make sure the terminals have locked into place.
- () Connect a 1" small bare wire between the two circuit boards as shown. Solder the wire to the foil side of each board. Then cut off the excess wire ends.
- () Refer to Detail 1-12E and bend the ears of the connector housing back as shown; then insert the housing down into the slot in the side of the VFO shield.

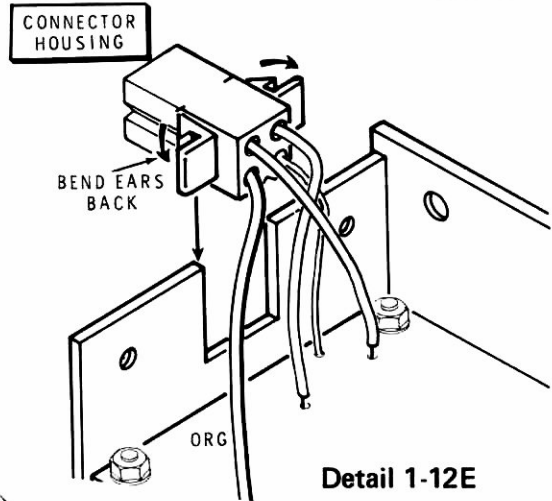

Detail 1-12E

- () Refer to Pictorial 1-13 and mount the VFO shield on the VFO chassis with #6 x 3/8" sheet metal screws at FB, FA, FN, FL, FK, FJ, HA, HB, HC, and HD.
- () Carefully peel away the backing paper from the blue and white label. Then press the label into place on the top of the VFO assembly, as shown. Make sure you recorded the label numbers in the label illustration in the Parts List.
- () Place the VFO assembly in an oven, set at no greater than 150°F for two hours. Then turn the oven off and allow the VFO to cool naturally while it is still in the oven. This will reduce stress in the VFO so it will be more stable during operation.

This completes the assembly of the VFO. Set it aside until it is called for in a step.

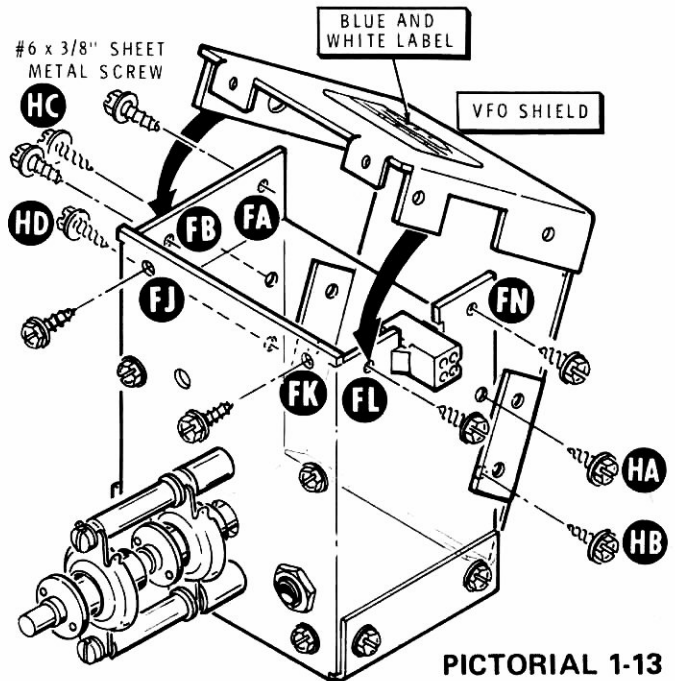

PICTORIAL 1-13

TRANSMITTER AUDIO/REG CIRCUIT BOARD

PARTS LIST

Remove the parts from Pack #2 and check each part against the following list. Make a check (✓) in the space provided as you identify each part. Any part that is packed in an individual envelope with the part number on it should be placed back in the envelope after you identify it until it is called for in a step. Do not throw away any packing materials until all parts are accounted for.

QTY.	DESCRIPTION	HEATH No.	CIRCUIT Component No.
()	1	100 Ω (brown-black-brown)	6-101 R226
()	1	150 Ω (brown-green-brown)	6-151 R252
()	1	220 Ω (red-red-brown)	6-221 R228
()	4	470 Ω (yellow-violet-brown)	6-471 R216, R236, R239, R255
()	1	750 Ω (violet-green-brown)	6-751 R254
()	5	1000 Ω (brown-black-red)	6-102 R219, R229, R231, R242, R253
()	1	2200 Ω (red-red-red)	6-222 R238
()	1	2700 Ω (red-violet-red)	6-272 R249
()	3	4700 Ω (yellow-violet-red)	6-472 R217, R221, R233
()	1	6800 Ω (blue-gray-red)	6-682 R243
()	4	10 kΩ (brown-black-orange)	6-103 R205, R232, R235, R237
()	1	15 kΩ (brown-green-orange)	6-153 R241

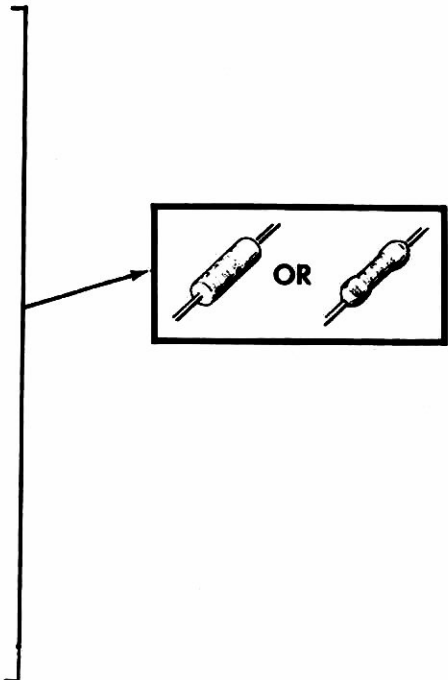

QTY.	DESCRIPTION	HEATH No.	CIRCUIT Component No.
() 3	22 kΩ (red-red-orange)	6-223	R201, R203, R215
() 3	33 kΩ (orange-orange-orange)	6-333	R209, R214, R244
() 2	47 kΩ (yellow-violet-orange)	6-473	R234, R251
() 1	100 kΩ (brown-black-yellow)	6-104	R227
() 5	120 kΩ, 10% (brown-red-yellow-silver)	1-121	R202, R204, R208, R222, R224
() 1	220 kΩ (red-red-yellow)	6-224	R213
() 1	330 kΩ (orange-orange-yellow)	6-334	R212
() 2	470 kΩ (yellow-violet-yellow)	6-474	R211, R248
() 1	680 kΩ (blue-gray-yellow)	6-684	R223
() 1	1.5 MΩ (brown-green-green)	6-155	R207
() 2	2.2 MΩ (red-red-green)	6-225	R206, R225
() 1	3.3 MΩ (orange-orange-green)	6-335	R245
() 1	4.7 MΩ (yellow-violet-green)	6-475	R218
() 2	10 MΩ, 10% (brown-black-blue-silver)	1-40	R246, R247

CAPACITORS

Disc			
() 1	.001 μF	21-163	C211
() 1	.05 μF	21-94	C223
() 13	.1 μF	21-199	C201, C202, C203, C206, C207, C213, C217, C218, C219, C221, C224, C225, C228
() 1	.01 μF	21-176	C204
Electrolytic			
() 1	.68 μF tantalum	25-200	C215
() 1	47 μF tantalum	25-223	C227
() 1	2 μF	25-123	C212
() 3	50 μF	25-98	C205, C209, C226
() 1	10 μF	25-115	C214

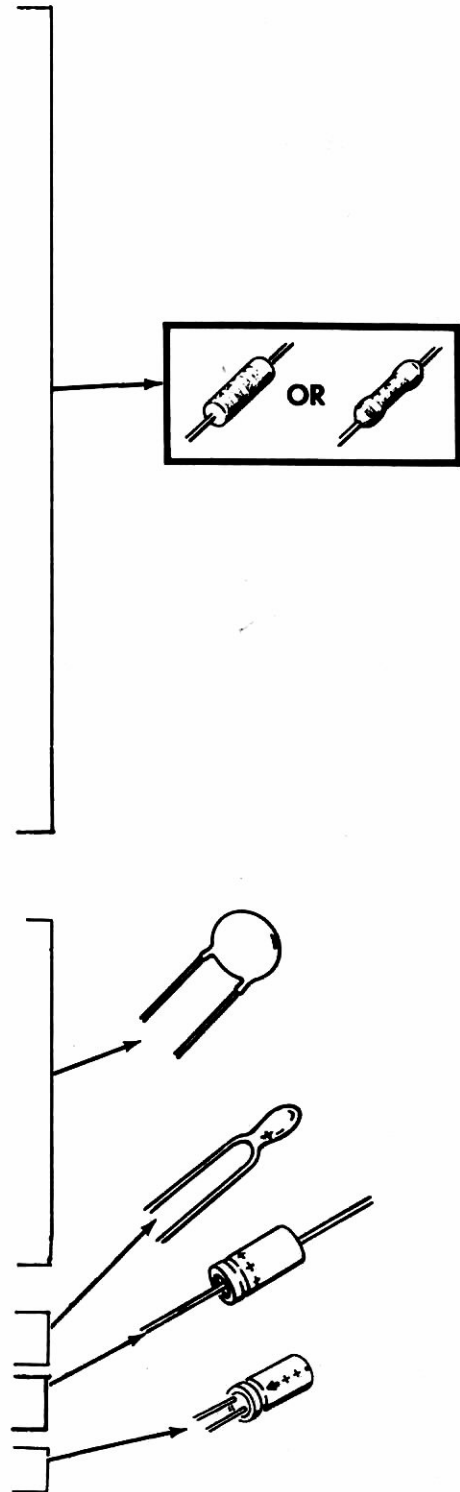

QTY.	DESCRIPTION	HEATH No.	CIRCUIT Component No.
Other			
() 1	.022 μ F Mylar*	27-63	C216
() 2	.1 μ F Mylar	27-47	C208, C222
DIODES			
() 2	Zener, 5.1 volt	56-16	ZD201, ZD203
() 1	Zener, 9.1 volt	56-19	ZD202
() 5	1N4149	56-56	D201, D202, D203, D204, D205
() 2	1N4002	57-65	D206, D207

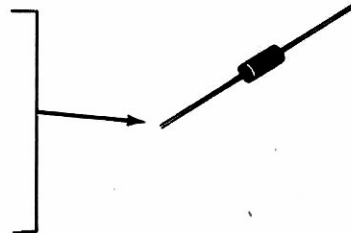
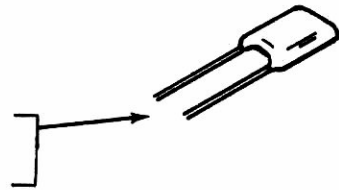

TRANSISTORS-INTEGRATED CIRCUITS

NOTE: Transistors and integrated circuits are marked for identification in one of the following four ways:

1. Part number.
2. Type number. (On integrated circuits this refers only to the numbers; the letters may be different or missing.)
3. Part number and type number.
4. Part number with a type number other than the one shown.

() 1	MPS6520	417-134	Q210
() 4	X29A829 transistor	417-201	Q202, Q204, Q207, Q208
() 5	MPSA20 transistor	417-801	Q201, Q203, Q205, Q206, Q209
() 2	MFC6030 integrated circuit	442-48	IC202, IC203
() 1	LM3900 integrated circuit	442-71	IC201

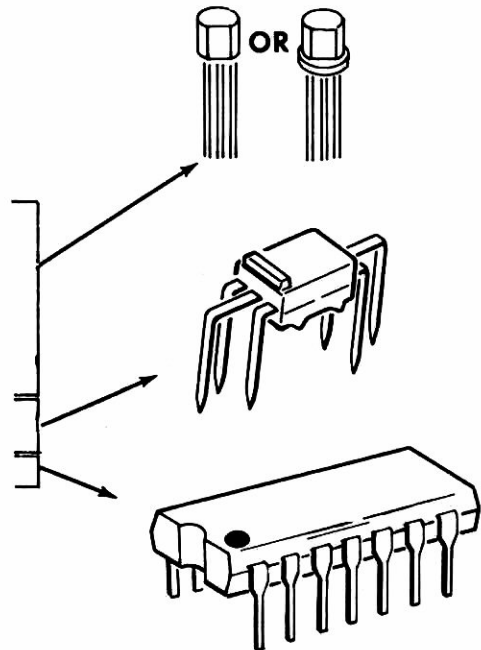

<u>QTY.</u>	<u>DESCRIPTION</u>	<u>HEATH No.</u>	<u>CIRCUIT Component No.</u>
MISCELLANEOUS			
() 2	Board puller	207-80	
() 24	Circuit board connector	432-124	
() 1	IC socket	434-298	
() 4	Ferrite bead	475-10	
() 1	IC puller	490-111	
PART FROM PACK #10			
() 1	Transmit audio/reg circuit board	85-1580-5	

To order a replacement part, always include the PART NUMBER. Use the Parts Order Form furnished with this kit. If one is not available, see "Replacement Parts" inside the rear cover of this Manual. Your Warranty is located inside the front cover. For pricing information, refer to the separate "Heath Parts Price List."

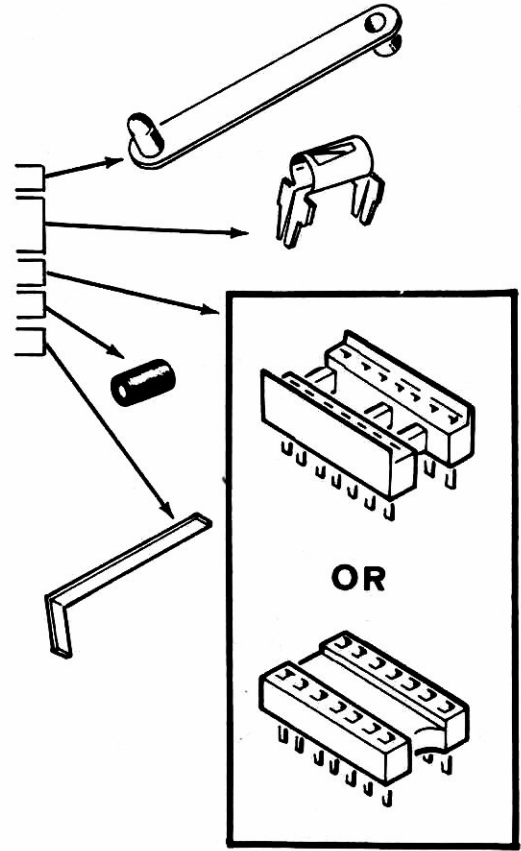

STEP-BY-STEP ASSEMBLY

TRANSMITTER AUDIO/REG CIRCUIT BOARD

START

Position the transmitter audio/reg circuit board as shown. Then complete each step in Pictorial 2-1 through 2-6.

FOR GOOD SOLDER CONNECTIONS, YOU MUST KEEP THE SOLDERING IRON TIP CLEAN. WIPE IT OFTEN WITH A DAMP SPONGE OR CLOTH.



Install circuit board connectors in the following manner. Note that inside each connector the spring contact is depressed on one end. This depressed end of the connector should face away from the edge of the circuit board. Insert the mounting tabs through the circuit board until the ridges of the connector are firmly against the circuit board. Look at the row of connector to make sure the depressed end of the contact of each connector is toward the center of the circuit board. Solder the tabs to the foil.

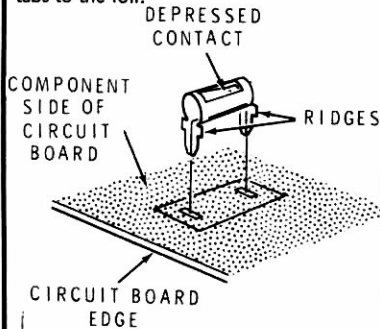

- () Six circuit board connectors.
- () Six circuit board connectors.
- () Six circuit board connectors.
- () Six circuit board connectors.

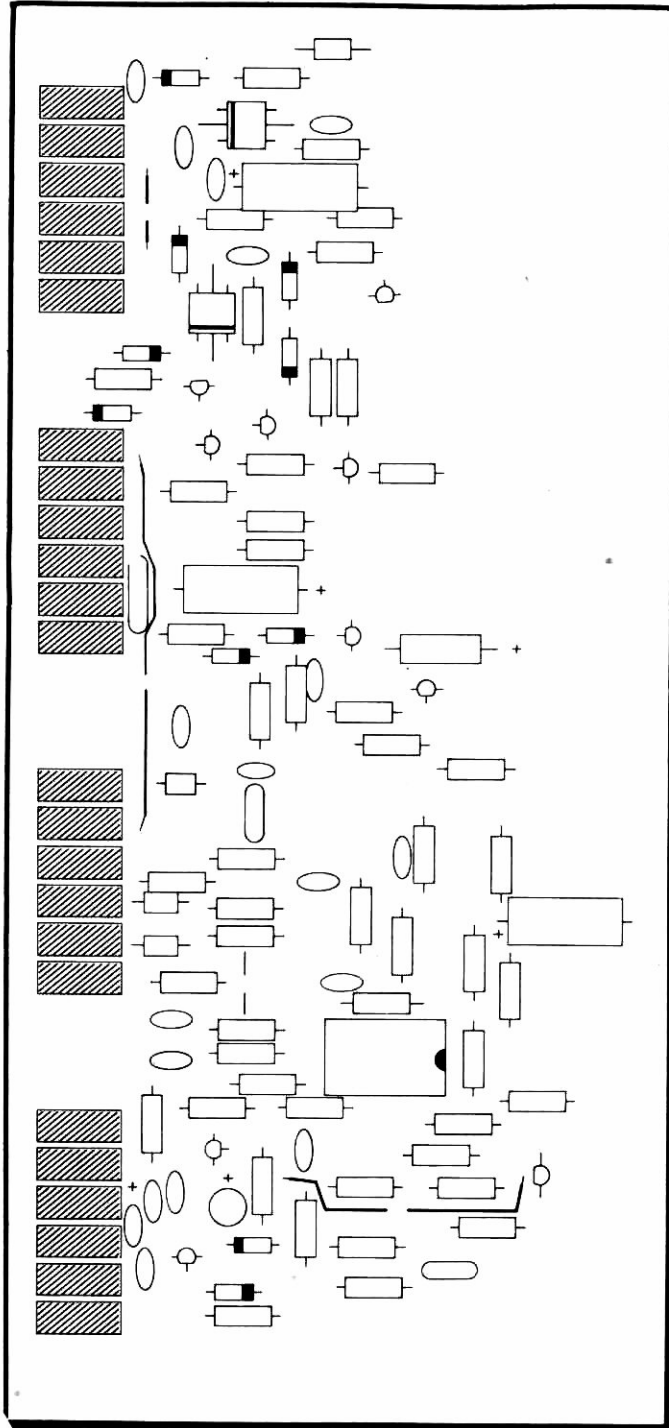

PICTORIAL 2-1

START

NOTE: When you install a diode, always match the banded end of the diode with the band mark on the circuit board.

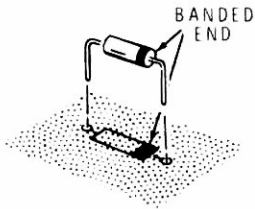

- Install 1N4002 diodes (#57-65) at:
- () D207.
 - () D206.
 - () ZD201: Zener diode (#56-16).
 - () ZD202: Zener diode (#56-19).
- Install four 1N4149 diodes (#56-56) at:
- () D204.
 - () D203.
 - () D201.
 - () D202.

- () Solder the leads to the foil and cut off the excess lead lengths.
- () FB: Install three ferrite beads. Use 1" small bare wires.

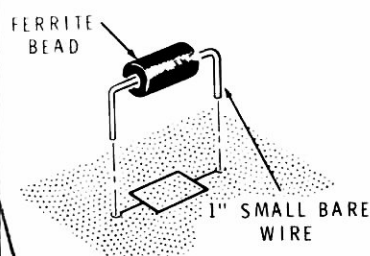

- () Jumper wire. Use a 1" small bare wire.
- () D205: 1N4149 diode (#56-56).
- () ZD203: Zener diode (#56-16).
- () Solder the leads to the foil and cut off the excess lead lengths.

IDENTIFICATION DRAWING

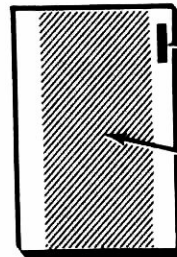

PART NUMBER

The steps performed in this Pictorial are in this area of the circuit board.

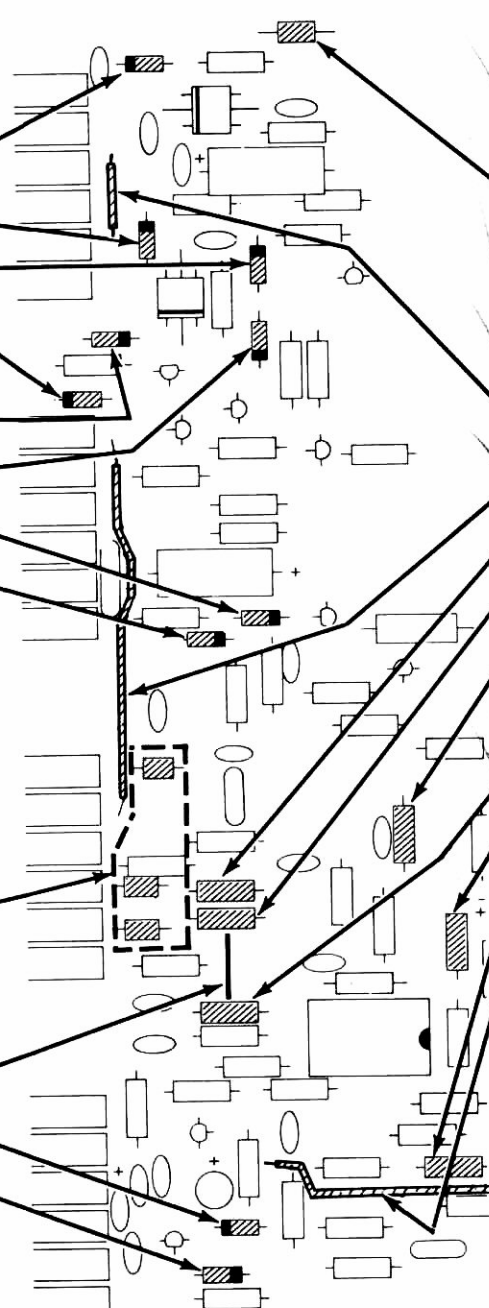

CONTINUE

- () FB: Ferrite bead.
- NOTE: When you install a jumper wire, cut it to the indicated length and remove 1/4" of insulation from each end. After the wire has been installed, use a small screwdriver to press it down against the circuit board.
- () 1" gray wire.
 - () 3" gray wire.
 - () R204: 120 kΩ (brown-red-yellow).
 - () R202: 120 kΩ (brown-red-yellow).
 - () R209: 33 kΩ (orange-orange-orange).
- Install three 120 kΩ (brown-red-yellow) resistors at:
- () R222.
 - () R208.
 - () R224.
- () 2-3/8" gray wire.
 - () Solder the leads to the foil and cut off the excess lead lengths.

PICTORIAL 2-2

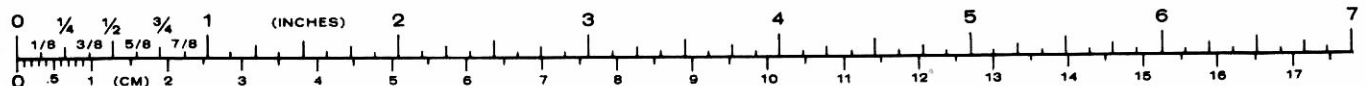

IDENTIFICATION
DRAWING

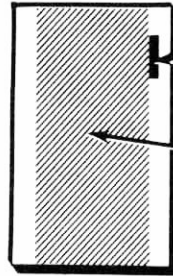

PART
NUMBER

The steps performed in this Pictorial are in
this area of the circuit board.

START →

- (✓) R254: 750 Ω (violet-green-brown).
- (✓) R252: 150 Ω (brown-green-brown).
- (✓) R231: 1000 Ω (brown-black-red).
- (✓) R253: 1000 Ω (brown-black-red).
- (✓) R217: 4700 Ω (yellow-violet-red).
- (✓) R237: 10 kΩ (brown-black-orange).
- (✓) R235: 10 kΩ (brown-black-orange).
- (✓) R229: 1000 Ω (brown-black-red).
- (✓) R227: 100 kΩ (brown-black-yellow).
- (✓) R226: 100 Ω (brown-black-brown).
- (✓) R205: 10 kΩ (brown-black-orange).
- (✓) Solder the leads to the foil and cut off the excess lead lengths.
- (✓) R203: 22 kΩ (red-red-orange).
- (✓) R201: 22 kΩ (red-red-orange).
- (✓) R212: 330 kΩ (orange-orange-yellow).
- (✓) R223: 680 kΩ (blue-gray-yellow).
- (✓) R248: 470 kΩ (yellow-violet-yellow).
- (✓) R249: 2700 Ω (red-violet-red).
- (✓) R251: 47 kΩ (yellow-violet-orange).
- (✓) R225: 2.2 MΩ (red-red-green).
- (✓) R243: 6800 Ω (blue-gray-red).
- (✓) R244: 33 kΩ (orange-orange-orange).
- (✓) R241: 15 kΩ (brown-green-orange).
- (✓) Solder the leads to the foil and cut off the excess lead lengths.

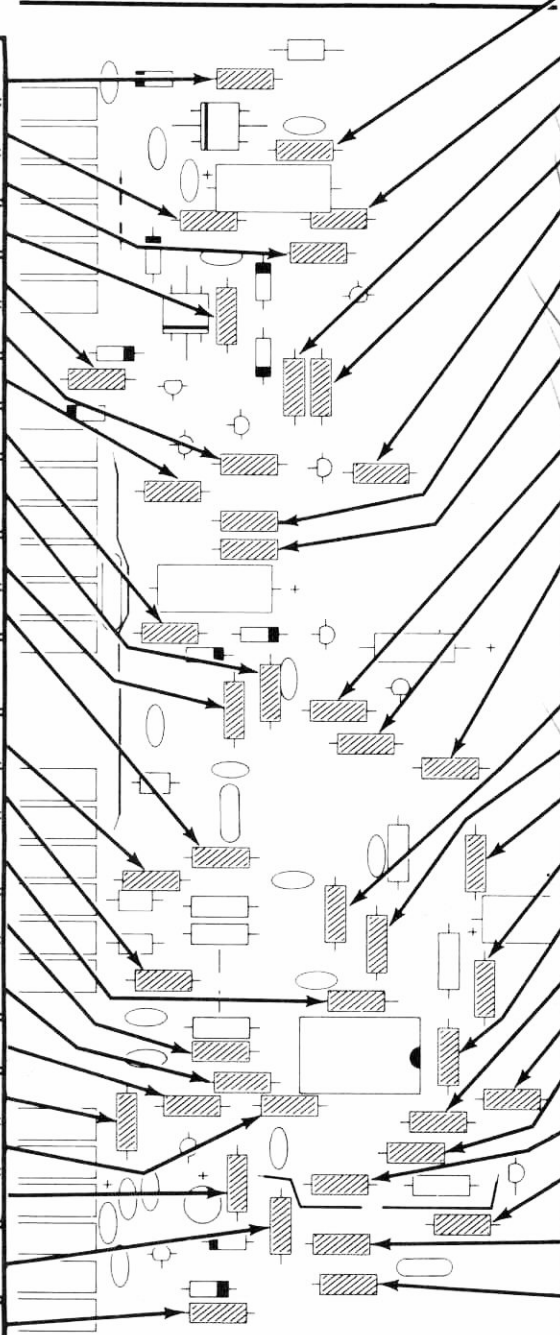

CONTINUE →

- (✓) R255: 470 Ω (yellow-violet-brown).
- (✓) R232: 10 kΩ (brown-black-orange).
- (✓) R234: 47 kΩ (yellow-violet-orange).
- (✓) R233: 4700 Ω (yellow-violet-red).
- (✓) R238: 2200 Ω (red-red-red).
- (✓) R236: 470 Ω (yellow-violet-brown).
- (✓) R239: 470 Ω (yellow-violet-brown).
- (✓) R216: 470 Ω (yellow-violet-brown).
- (✓) R215: 22 kΩ (red-red-orange).
- (✓) R214: 33 kΩ (orange-orange-orange).
- (✓) Solder the leads to the foil and cut off the excess lead lengths.
- (✓) R206: 2.2 MΩ (red-red-green).
- (✓) R213: 220 kΩ (red-red-yellow).
- (✓) R228: 220 Ω (red-red-brown).
- (✓) R211: 470 kΩ (yellow-violet-yellow).
- (✓) R207: 1.5 MΩ (brown-green-green).
- (✓) R218: 4.7 MΩ (yellow-violet-green).
- (✓) R219: 1000 Ω (brown-black-red).
- (✓) R246: 10 MΩ (brown-black-blue).
- (✓) R247: 10 MΩ (brown-black-blue).
- (✓) R221: 4700 Ω (yellow-violet-red).
- (✓) R245: 3.3 MΩ (orange-orange-green).
- (✓) R242: 1000 Ω (brown-black-red).
- (✓) Solder the leads to the foil and cut off the excess lead lengths.

IDENTIFICATION
DRAWING

PART
NUMBER

The steps performed in this Pictorial are in
this area of the circuit board.

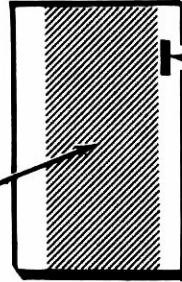

START →

Install three .1 μ F disc capacitors at:

- () C228
- () C225
- () C224

() C223: .05 μ F disc.

FOR GOOD SOLDER CONNECTIONS, YOU MUST KEEP THE SOLDERING IRON TIP CLEAN. WIPE IT OFTEN WITH A DAMP SPONGE OR CLOTH.

() Solder the leads to the foil and cut off the excess lead lengths.

() C222: .1 μ F Mylar.

Install two .1 μ F disc capacitors at:

- () C217
- () C203
- () C208: .1 μ F Mylar.

Install eight .1 μ F disc capacitors at:

- () C202
- () C201
- () C206
- () C207
- () C218
- () C219
- () C221
- () C213

() Solder the leads to the foil and cut off the excess lead lengths.

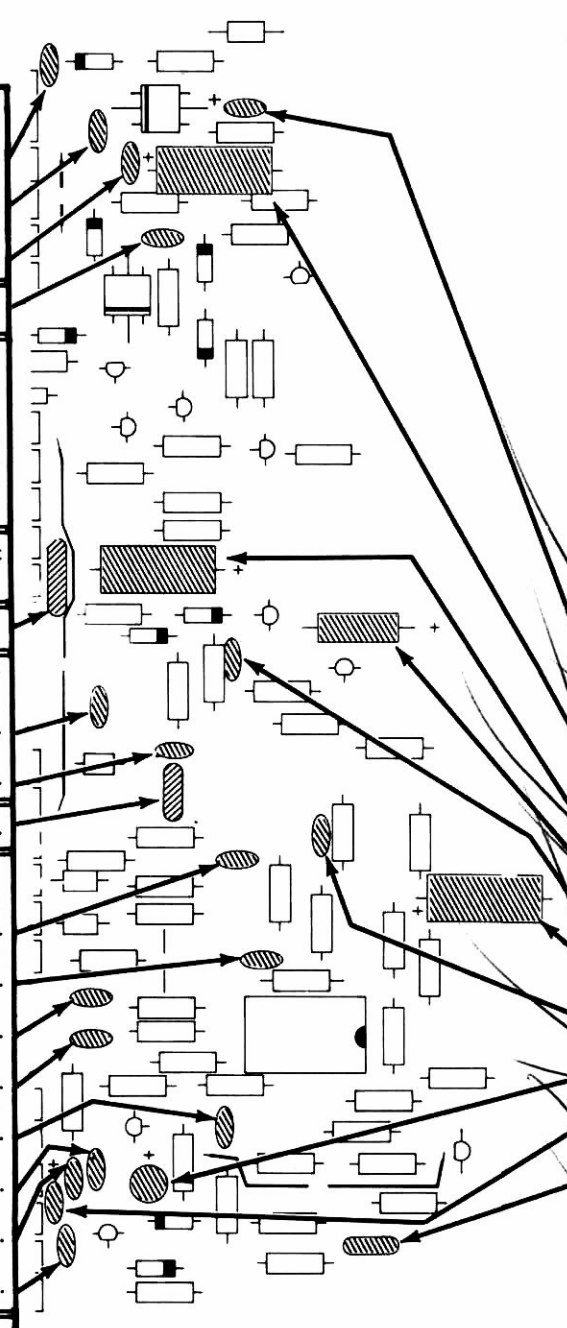

CONTINUE →

NOTE: When you install electrolytic and tantalum capacitors, be sure to match the positive (+) capacitor lead (or color dot) with the positive (+) mark on the circuit board. Be careful, only the negative lead may be marked.

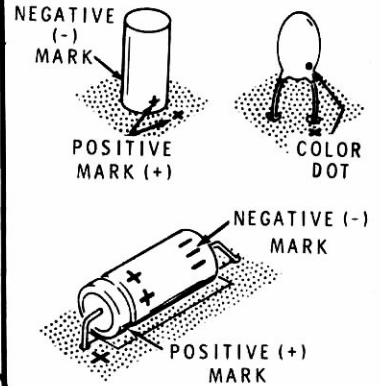

() C227: 47 μ F tantalum.

Install two 50 μ F electrolytic capacitors at:

- () C226.
- () C205.
- () C212: 2 μ F electrolytic.
- () C211: .001 μ F disc.
- () C209: 50 μ F electrolytic.
- () C204: .01 μ F disc.
- () C214: 10 μ F electrolytic.
- () C215: .68 μ F tantalum.
- () C216: .022 μ F Mylar.

() Solder the leads to the foil and cut off the excess lead lengths.

PICTORIAL 2-4

IDENTIFICATION
DRAWING

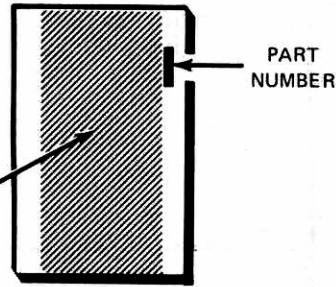

The steps performed in this Pictorial are in this area of the circuit board.

START

NOTE: Install the following transistors in the manner shown. First line up the flat of the transistor with the outline of the flat on the circuit board. Insert the transistor leads into their correct holes, indicated by E, B, and C. Solder each lead to the foil and cut off the excess lead lengths.

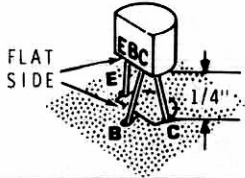

Install four MPSA20 transistors (#417-801) at:

- () Q205
- () Q206
- () Q203
- () Q201

() Q210: MPS6520 transistor (#417-134).

() Q209: MPSA20 transistor (#417-801).

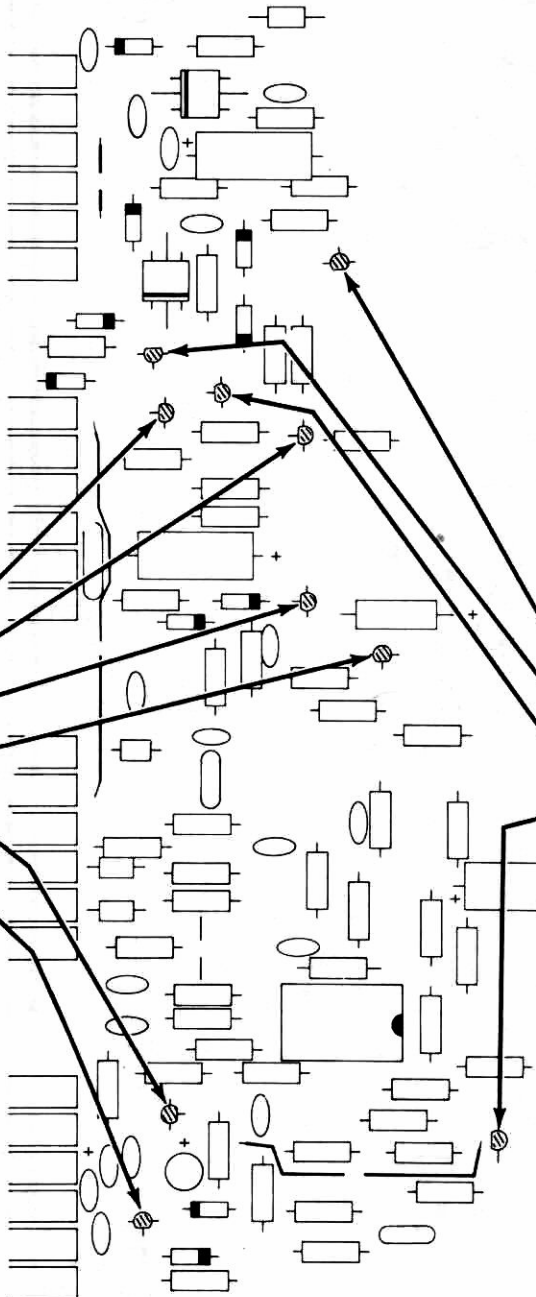

CONTINUE

NOTE: Install the following transistors in the manner shown. First line up the flat of the transistor with the outline of the flat on the circuit board. Bend the "C" lead forward or backward as required, and insert the transistor leads into their correct holes, indicated by E, C, and B. Solder each lead to the foil and cut off the excess lead length.

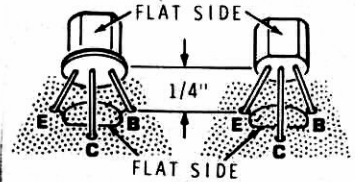

Install four X29A829 transistors (#417-201) at:

- () Q204.
- () Q207.
- () Q208.
- () Q202.

NOTE: An IC lifter has been furnished to remove an IC from its socket if necessary (IC's are installed on the next page).

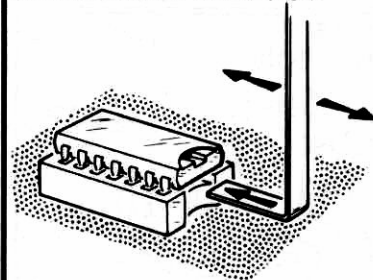

To use the lifter, push the shorter end in between the IC and the socket and rock the longer portion back and forth. Be careful as the IC pins are easily bent.

START

Install two IC's as follows. Position the ridge or dot of the IC over the band screened on the circuit board. Then insert the IC leads into their corresponding holes, press the IC down tight against the circuit board and solder each lead to the foil.

RIDGE OR DOT

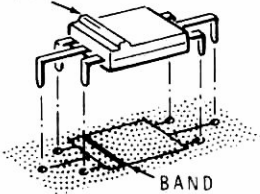

BAND

() IC203: MFC6030 (#442-48).

() IC202: MFC6030 (#442-48).

() IC socket at IC201. Insert the socket pins into the holes. The half-moon mark on the circuit board should still be visible after it is installed. Solder the pins to the foil.

NOTE: Refer to Detail 2-6A for ways to identify the pin 1 end of integrated circuits in this kit.

() IC201: LM3900N integrated circuit (#442-71). Position the pin 1 end of the IC over the half-moon mark on the circuit board, and carefully insert each pin into the socket. See Page 39 for the use of the IC lifter.

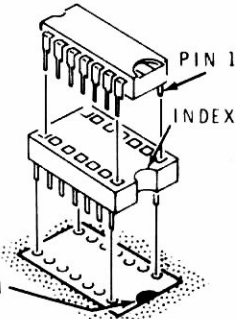

HALF-MOON MARK

SMALL INDENTATION



PIN 1

RIDGE



PIN 1

NOTCH



PIN 1

PIN 1

NOTCH



PIN 1

Detail 2-6A

IDENTIFICATION DRAWING



PART NUMBER

The steps performed in this Pictorial are in this area of the circuit board.

CONTINUE

() Mount board pullers on the foil side of the circuit board at holes A and B. Position the female part in the circuit board; then push the male part through the female part.

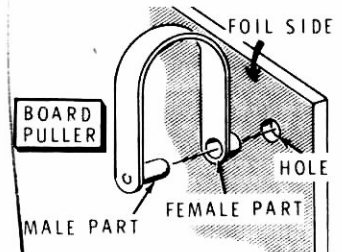

BOARD PULLER

FOIL SIDE

HOLE

MALE PART

FEMALE PART

() Cut a large letter "B" from the terminal identification label (#390-1045) and remove the adhesive backing. Press the letter onto the circuit board at the location shown.

CIRCUIT BOARD CHECKOUT

Carefully inspect the circuit board for the following conditions.

- () Unsoldered connections.
- () "Cold" solder connections.
- () Solder bridges between foils.
- () Protruding leads. No lead should be longer than 1/8".
- () Transistors for the proper type and installation.
- () Integrated circuits for the proper type and installation.
- () Electrolytic capacitors for the correct position of the positive (+) lead.
- () Diodes for the correct position of the banded end.
- () Lay the circuit board aside. It will be used later.

FINISH

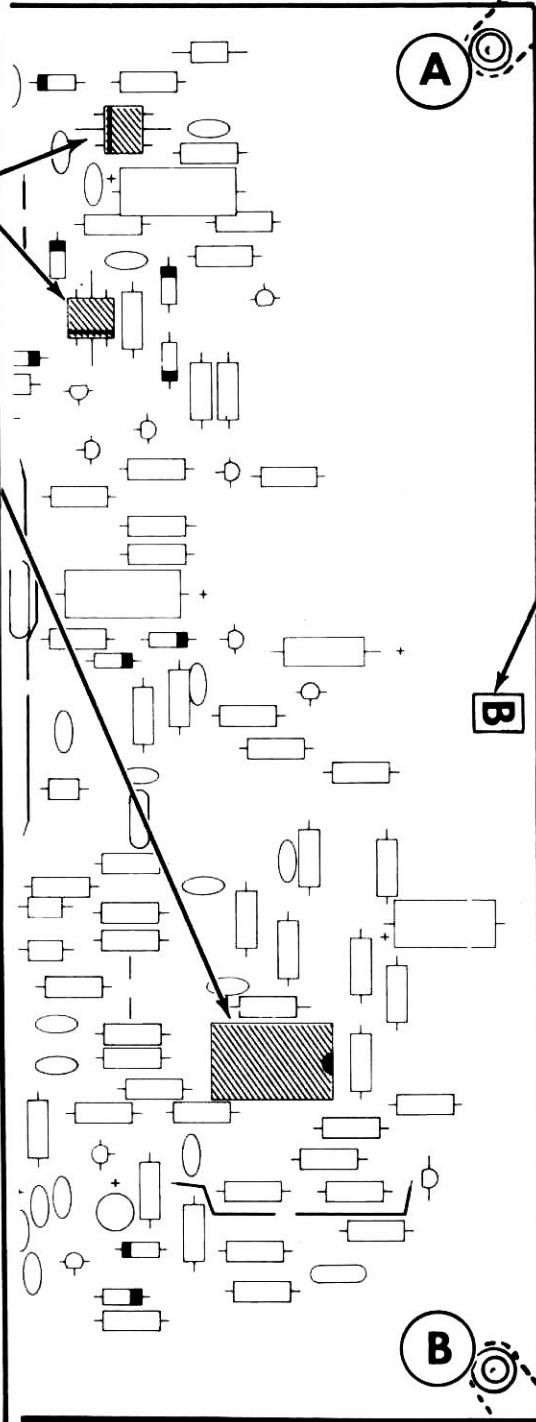

PICTORIAL 2-6

HFO/PREMIER CIRCUII BOARD

PARTS LIST

Remove the parts from Pack #3 and check each part against the following list. Make a check (✓) in the space provided as you identify each part. Any part that is packed in an individual envelope with the part number on it should be placed back in the envelope after you identify it until it is called for in a step. Do not throw away any packing materials until all parts are accounted for.

QTY.	DESCRIPTION	HEATH No.	CIRCUIT Component No.
RESISTORS, 1/2-Watt			
() 3	22 Ω (red-red-black)	6-220	R439, R445, R449
() 1	39 Ω (orange-white-black)	6-390	R455
() 1	100 Ω (brown-black-brown)	6-101	R444
() 1	220 Ω (red-red-brown)	6-221	R446
() 5	470 Ω (yellow-violet-brown)	6-471	R405, R417, R426, R435, R441
() 22	1000 Ω (brown-black-red)	6-102	R401, R406, R409, R413, R418, R422, R427, R431, R436, R454, R456, R457, R458, R459, R462, R463, R464, R465, R466, R467, R468, R469

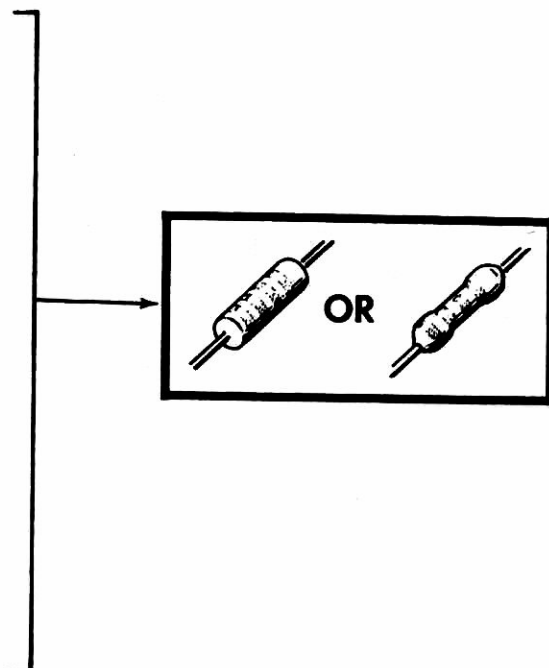

QTY.	DESCRIPTION	HEATH No.	CIRCUIT Component No.
------	-------------	-----------	-----------------------

Resistors (cont'd.)

()	3	2200 Ω (red-red-red)	6-222	R451, R452, R471
()	4	3300 Ω (orange-orange-red)	6-332	R404, R416, R425, R434
()	1	3900 Ω (orange-white-red)	6-392	R453
()	8	4700 Ω (yellow-violet-red)	6-472	R419, R424, R428, R433, R437, R461, R472, R473
()	4	15 kΩ (brown-green-orange)	6-153	R403, R407, R411, R414
()	3	22 kΩ (red-red-orange)	6-223	R443, R447, R448
()	1	47 kΩ (yellow-violet-orange)	6-473	R442
()	9	100 kΩ (brown-black-yellow)	6-104	R402, R408, R412, R415, R421, R423, R429, R432, R438

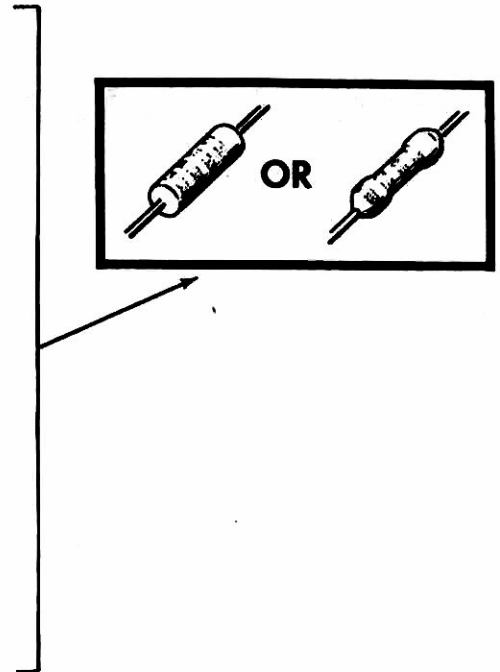

CAPACITORS

Mica

()	4	12 pF	20-130	C461, C463, C465, C467
()	2	30 pF	20-100	C456, C458
()	2	33 pF	20-160	C471, C475
()	2	47 pF	20-101	C409, C412
()	4	75 pF	20-110	C452, C454, C462, C466
()	2	100 pF	20-148	C401, C405
()	1	300 pF	20-115	C457
()	1	470 pF	20-128	C453

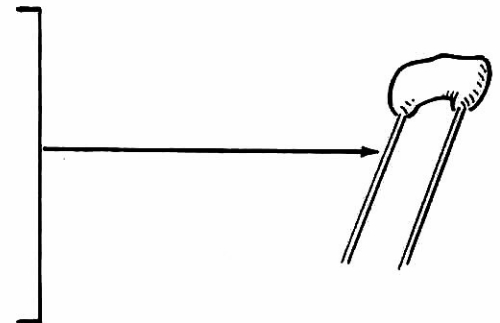

QTY.	DESCRIPTION	HEATH No.	CIRCUIT Component No.
Disc			
() 1	2.7 pF	21-149	C444
() 1	3.3 pF	21-33	C407
() 6	5 pF	21-157	C403, C413, C421, C428, C474, C476
() 2	6 pF	21-169	C469, C472
() 4	7.7 pF	21-181	C418, C425, C426, C433
() 6	10 pF	21-3	C404, C416, C422, C423, C429, C431
() 1	18 pF	21-60	C414
() 1	24 pF	21-84	C417
() 1	33 pF	21-7	C441
() 2	100 pF	21-9	C437, C439
() 1	270 pF	21-17	C447
() 2	.001 μ F	21-140	C443, C446
() 22	.01 μ F	21-176	C402, C406, C408, C411, C415, C419, C424, C427, C432, C434, C435, C436, C438, C442, C445, C448, C451, C455, C459, C464, C468, C473
() 1	.1 μ F	21-95	C449

INDUCTORS

() 8	0.5 μ H coil (green dot)	40-687	L402, L403, L404, L405, L406, L407, L408, L409
() 1	1.42 μ H coil (gray dot)	40-1047	L401
() 2	Transformer	40-1050	L422, L423
() 6	3.975 μ H coil (red dot)	40-1879	L416, L417, L418, L419, L420, L421
() 6	7.95 μ H coil	40-1672	L410, L411, L412, L413, L414, L415
() 2	2.2 μ H inductor	45-73	RFC401, RFC402
() 1	30 μ H inductor	45-27	RFC403
() 8	Ferrite bead	475-10	

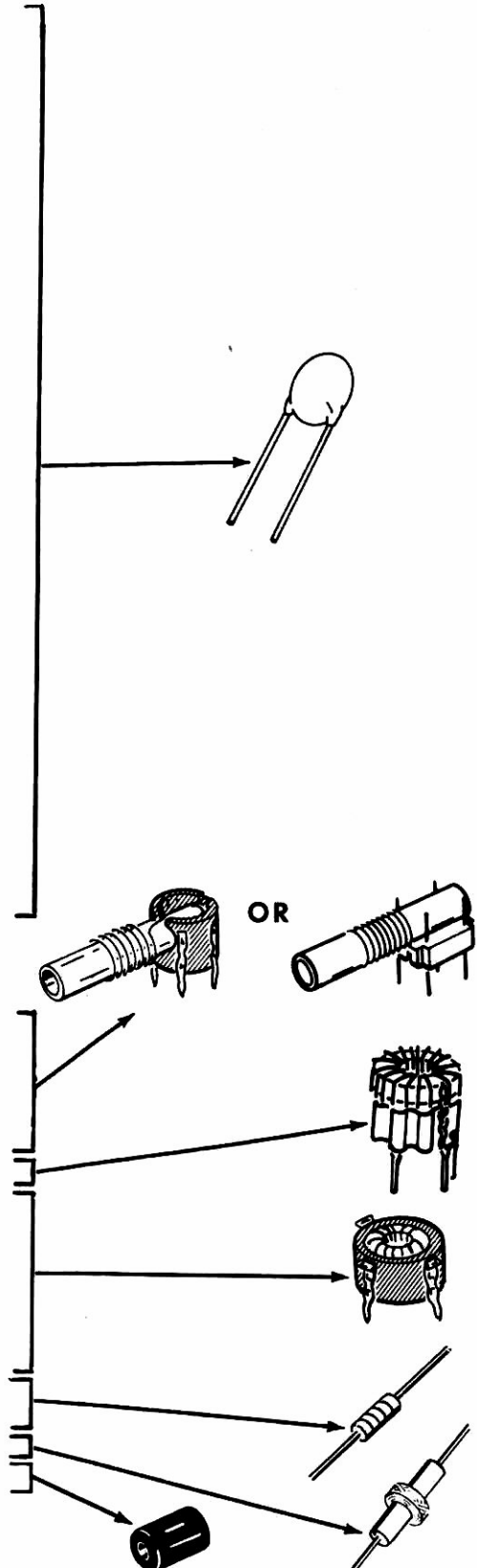

QTY.	DESCRIPTION	HEATH No.	CIRCUIT Component No.
------	-------------	-----------	-----------------------

DIODES-TRANSISTORS

()	12	1N458 diode	56-24	D431, D432, D433, D434, D435, D436, D437, D438, D439, D440, D441, D442
()	1	1N191 diode	56-26	D426
()	24	1N4149 diode	56-56	D401, D402, D403, D404, D405, D406, D407, D408, D409, D410, D411, D412, D413, D414, D415, D416, D417, D418, D419, D420, D421, D422, D423, D425
()	4	FH1100 diode	56-87	D427, D428, D429, D430
()	2	2N2369 transistor	417-154	Q405, Q406
()	4	MPS6521 transistor	417-172	Q401, Q402, Q403, Q404
()	1	2N3866 transistor	417-205	Q407

CRYSTALS

()	1	12.395 MHz	404-415	Y401
()	1	15.895 MHz	404-416	Y402
()	1	22.895 MHz	404-417	Y403
()	1	23.895 MHz	404-543	Y404
()	1	29.895 MHz	404-418	Y405
()	1	36.895 MHz	404-419	Y406
()	1	37.395 MHz	404-420	Y407
()	1	37.895 MHz	404-421	Y408
()	1	38.395 MHz	404-422	Y409

NOTE: HEATH PART NUMBERS ARE STAMPED ON MOST DIODES.

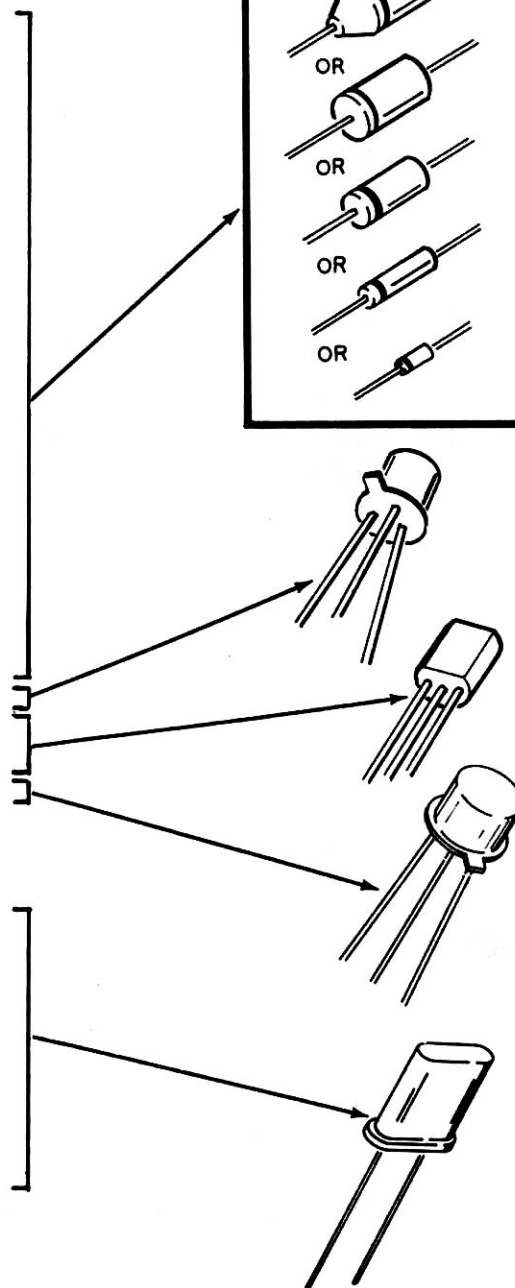
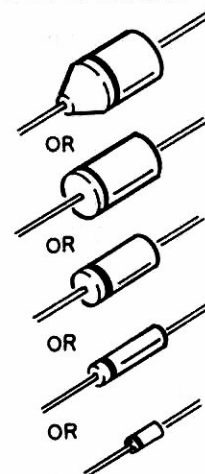

QTY.	DESCRIPTION	HEATH No.	CIRCUIT Component No.
MISCELLANEOUS			
() 2	Board puller	207-80	
() 18	Circuit board connector	432-124	
PART FROM PACK #10			
() 1	Circuit board	85-1418-4	

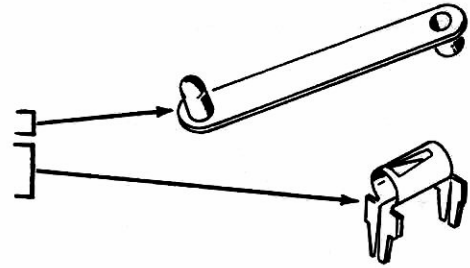

To order a replacement part, always include the PART NUMBER. Use the Parts Order Form furnished with this kit. If one is not available, see "Replacement Parts" inside the rear cover of this Manual. Your Warranty is located inside the front cover. For pricing information, refer to the separate "Heath Parts Price List."

STEP-BY-STEP ASSEMBLY

HFO/PREMIER CIRCUIT BOARD

START

Position the HFO/Premixer circuit board (#85-1418-4) as shown. Then proceed with the following steps.

Install circuit board connectors in the following manner. Note that inside each connector the spring contact is depressed on one end. This depressed end of the connector should face away from the edge of the circuit board. Insert the mounting tabs through the circuit board until the ridges of the connector are firmly against the circuit board. Look at the row of connectors to make sure the depressed end of the contact of each connector is toward the center of the circuit board. Solder the tabs to the foil.

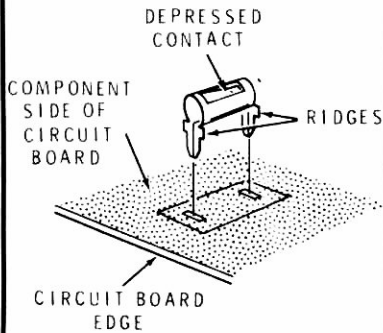

1) Six circuit board connectors.

2) Six circuit board connectors.

3) Six circuit board connectors.

4) Prepare both ends of a 5" shielded cable as follows. DO NOT use the RG-58A/U coaxial cable.

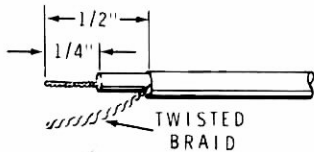

Remove 1/2" of the outer insulation. Then remove 1/4" of insulation from the inner lead.

5) Install the shielded cable as shown. Form the cable to the outline on the board. Be sure the shield leads and the inner leads are installed as indicated. Solder the leads to the foil and cut off the excess lead lengths.

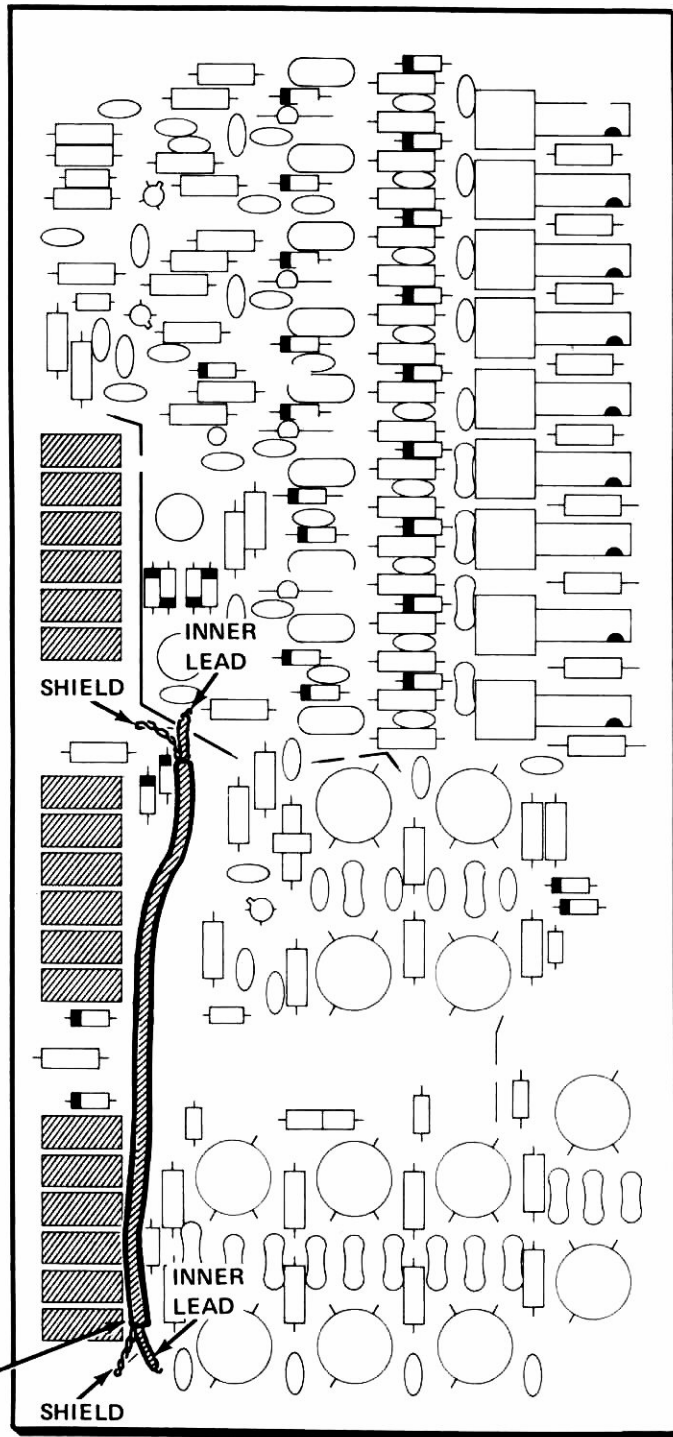

PICTORIAL 3-1

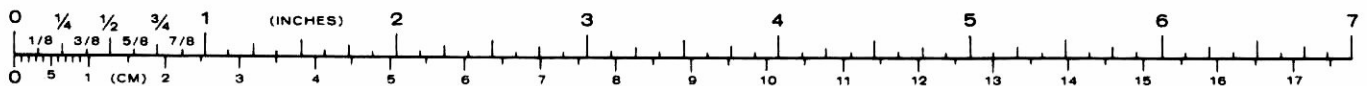

The steps performed in this Pictorial are in this area of the circuit board.

IDENTIFICATION DRAWING

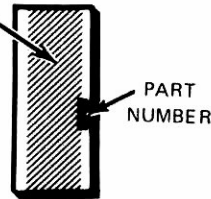

START

- () Set aside the twelve 1N458 diodes (#56-24). These will be installed later.

NOTE: When you install a diode, always match the banded end on the diode with the band mark on the circuit board.

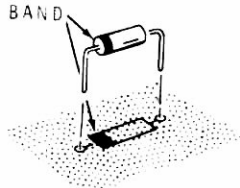

- () D426: 1N191 diode (#56-26).

- () D427-D430: Four FH1100 diodes (#56-87).

- () D423, D425: Two 1N4149 diodes (#56-56). Make sure the lead at the banded end of diode D425 does not touch and short circuit the lead of the nearby shielded cable.

- () D421, D422: Two 1N4149 diodes (#56-56).

- () D419, D420: Two 1N4149 diodes (#56-56).

FOR GOOD SOLDER CONNECTIONS, YOU MUST KEEP THE SOLDERING IRON TIP CLEAN. WIPE IT OFTEN WITH A DAMP SPONGE OR CLOTH.

- () Solder the leads to the foil and cut off the excess lead lengths.

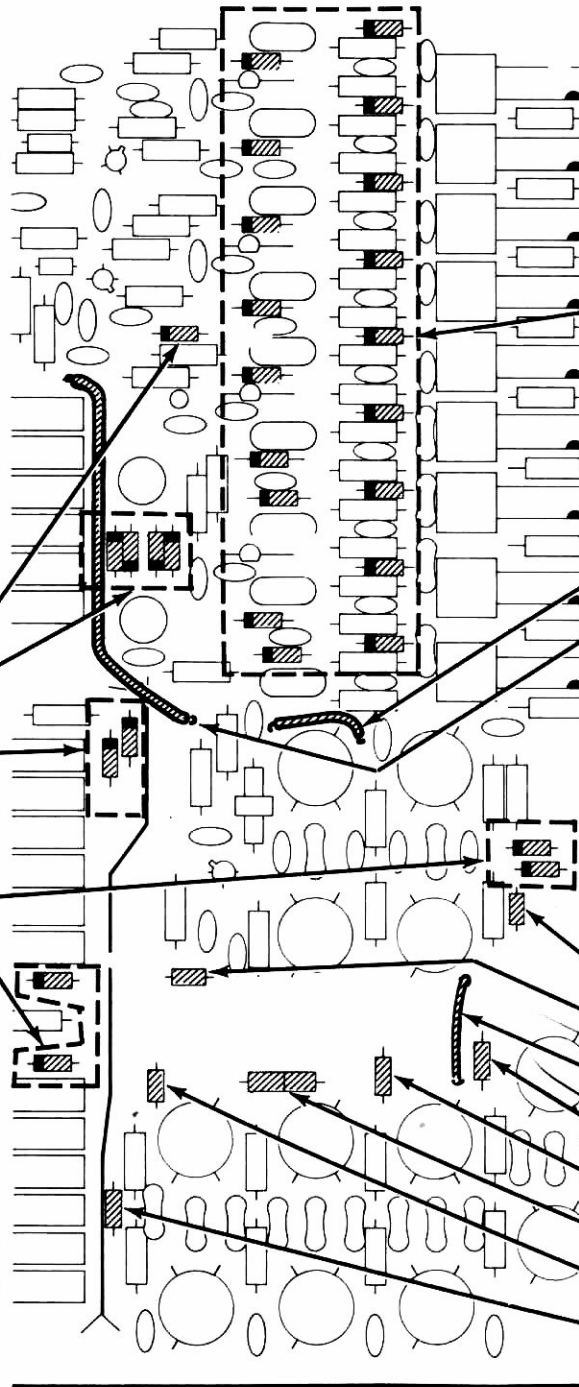

CONTINUE

- () D401-D418: Eighteen 1N4149 diodes (#56-56).

- () Solder the leads to the foil and cut off the excess lead lengths.

- () Prepare a 1-1/8" and a 3-1/4" gray wire. As you install each wire, solder it to the foil and cut off the excess wire lengths.

- () 1-1/8" gray wire at J.

- () 3-1/4" gray wire at J.

NOTE: When you install a ferrite bead, use a 1" small bare wire to mount the bead to the circuit board.



- () Ferrite bead.

- () Ferrite bead.

- () 1" small bare wire at J.

- () Ferrite bead.

- () Ferrite bead.

- () Two ferrite beads.

- () Ferrite bead.

- () Ferrite bead.

- () Solder the leads to the foil and cut off the excess lead lengths.

PICTORIAL 3-2

The steps performed in this Pictorial are in this area of the circuit board.

IDENTIFICATION DRAWING

PART NUMBER

START ↘

Install nine 100 kΩ (brown-black-yellow) resistors at:

- () R438.
- () R432.
- () R429.
- () R423.
- () R421.
- () R415.
- () R412.
- () R408.
- () R402.

() Solder the leads to the foil and cut off the excess lead lengths.

- () R452: 2200 Ω (red-red-red).
- () R454: 1000 Ω (brown-black-red).
- () R453: 3900 Ω (orange-white-red).
- () R455: 39 Ω (orange-white-black).
- () R471: 2200 Ω (red-red-red).

() Solder the leads to the foil and cut off the excess lead lengths.

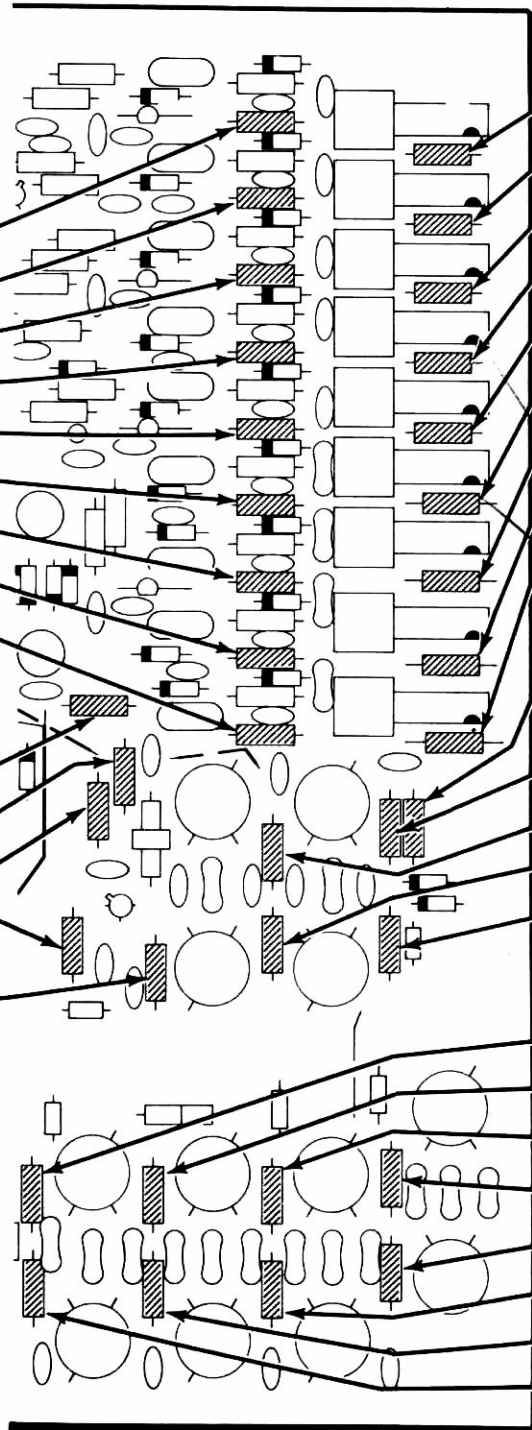

CONTINUE ↘

Install nine 1000 Ω (brown-black-red) resistors at:

- () R436.
- () R431.
- () R427.
- () R422.
- () R418.
- () R413.
- () R409.
- () R406.
- () R401.

() Solder the leads to the foil and cut off the excess lead lengths.

- () R472: 4700 Ω (yellow-violet-red).

Install four 1000 Ω (brown-black-red) resistors at:

- () R466.
- () R468.
- () R469.
- () R467.

Install eight 1000 Ω (brown-black-red) resistors at:

- () R457.
- () R459.
- () R463.
- () R465.
- () R464.
- () R462.
- () R458.
- () R456.

() Solder the leads to the foil and cut off the excess lead lengths.

PICTORIAL 3-3

The steps performed in this Pictorial are in this area of the circuit board.

START

- () R439: 22 Ω (red-red-black).
- () R441: 470 Ω (yellow-violet-brown).
- () R442: 47 kΩ (yellow-violet-orange).
- () R425: 3300 Ω (orange-orange-red).
- () R426: 470 Ω (yellow-violet-brown).
- () R447: 22 kΩ (red-red-orange).
- () R448: 22 kΩ (red-red-orange).
- () R446: 220 Ω (red-red-brown).
- () Solder the leads to the foil and cut off the excess lead lengths.
- () R445: 22 Ω (red-red-black).
- () R449: 22 Ω (red-red-black).
- () R416: 3300 Ω (orange-orange-red).
- () R417: 470 Ω (yellow-violet-brown).
- () R405: 470 Ω (yellow-violet-brown).
- () R404: 3300 Ω (orange-orange-red).
- () R473: 4700 Ω (yellow-violet-red).
- () R461: 4700 Ω (yellow-violet-red).
- () Solder the leads to the foil and cut off the excess lead lengths.

IDENTIFICATION DRAWING

PART NUMBER

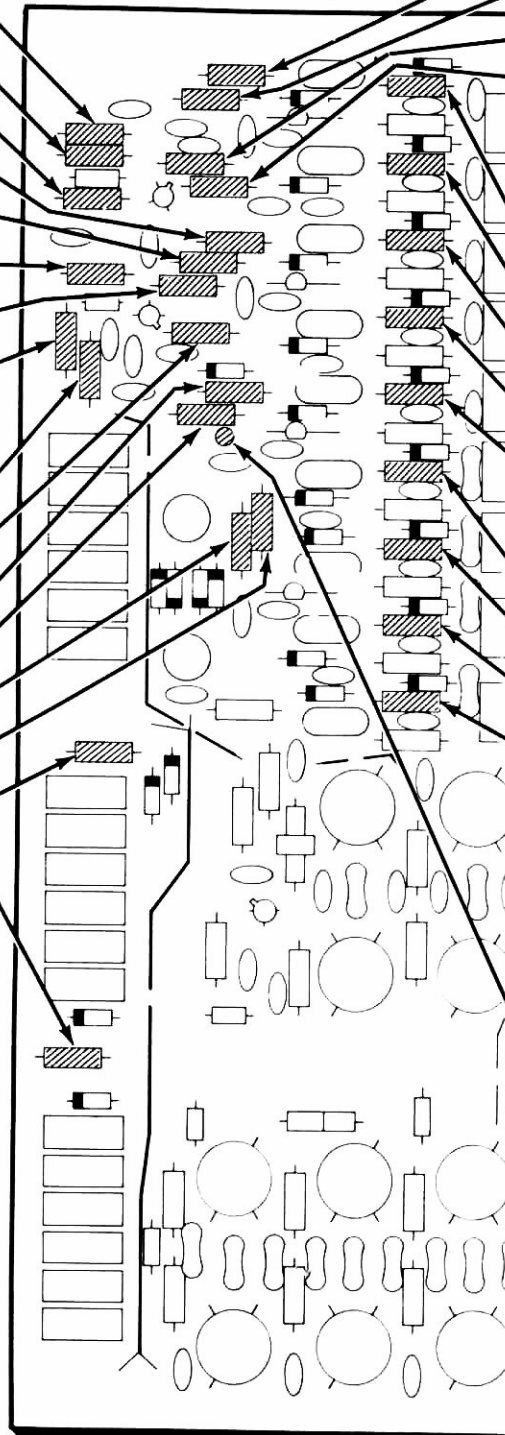

CONTINUE

- () R434: 3300 Ω (orange-orange-red).
- () R435: 470 Ω (yellow-violet-brown).
- () R444: 100 Ω (brown-black-brown).
- () R443: 22 kΩ (red-red-orange).
- () Solder the leads to the foil and cut off the excess lead lengths.
- Install five 4700 Ω (yellow-violet-red) resistors at:
 - () R437.
 - () R433.
 - () R428.
 - () R424.
 - () R419.
- Install four 15 kΩ (brown-green-orange) resistors at:
 - () R414.
 - () R411.
 - () R407.
 - () R403.
- () Solder the leads to the foil and cut off the excess lead lengths.
- () R451: 2200 Ω (red-red-red).
 1. Cut one lead of this resistor to 3/8". Form this lead into a loop; then crimp the loop tightly as shown.
 2. Install the long lead of this resistor at "2200 TP." Solder the lead to the foil and cut off the excess lead.

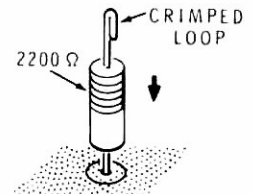

NOTE: The loop on this resistor is TP (test point).

PICTORIAL 3-4

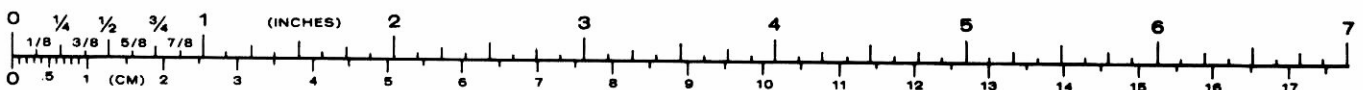

The steps performed in this Pictorial are in this area of the circuit board.

IDENTIFICATION DRAWING



PART NUMBER

START ▾

Install five .01 μ F disc capacitors at:

- () C435.
- () C436.
- () C438.
- () C442.
- () C434.

Install nine .01 μ F disc capacitors at:

- () C432.
- () C427.
- () C424.
- () C419.
- () C415.
- () C411.
- () C408.
- () C406.
- () C402.

() Solder the leads to the foil and cut off the excess lead lengths.

Install four .01 μ F disc capacitors at:

- () C445.
- () C473.
- () C468.
- () C448.

Install four .01 μ F disc capacitors at:

- () C464.
- () C459.
- () C455.
- () C451.

() Solder the leads to the foil and cut off the excess lead lengths.

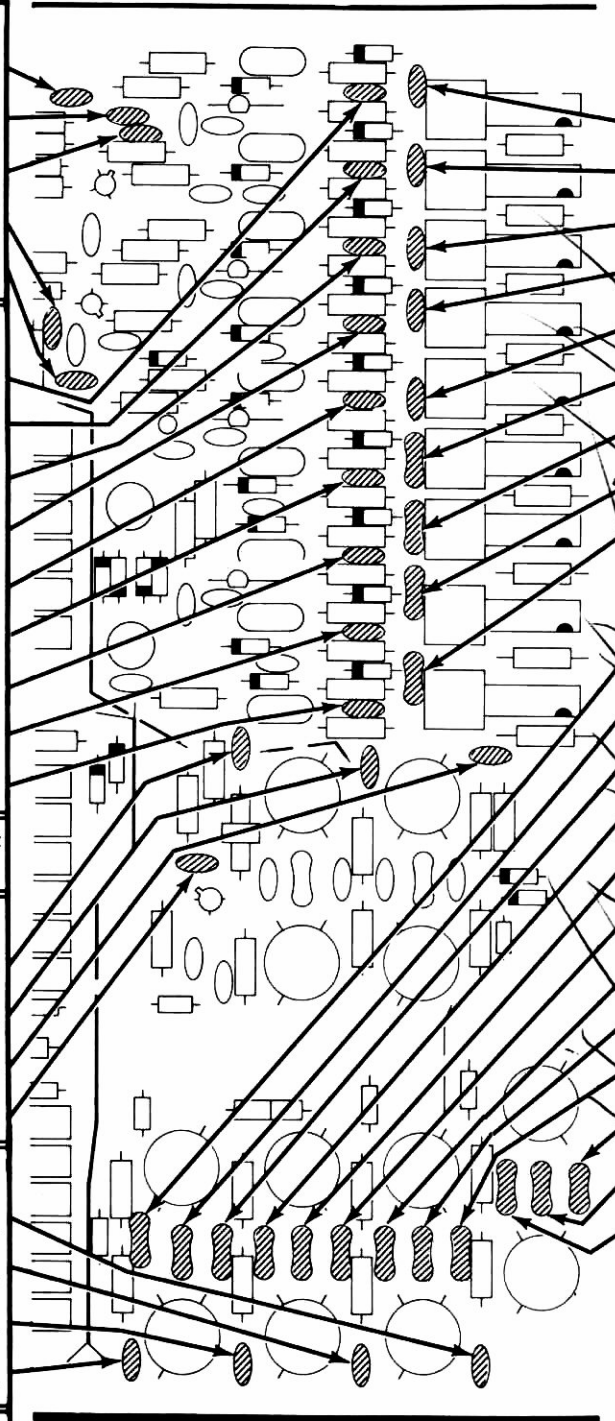

CONTINUE ▾

Install four 7.7 pF disc capacitors at:

- () C433.
- () C426.
- () C425.
- () C418.
- () C417: 24 pF disc.
- () C412: 47 pF mica.
- () C409: 47 pF mica.
- () C405: 100 pF mica.
- () C401: 100 pF mica.
- () Solder the leads to the foil and cut off the excess lead lengths.
- () C452: 75 pF mica.
- () C453: 470 pF mica.
- () C454: 75 pF mica.
- () C456: 30 pF mica.
- () C457: 300 pF mica.
- () C458: 30 pF mica.
- () C461: 12 pF mica.
- () C462: 75 pF mica.
- () C463: 12 pF mica.
- () C465: 12 pF mica.
- () C466: 75 pF mica.
- () C467: 12 pF mica.
- () Solder the leads to the foil and cut off the excess lead lengths.

PICTORIAL 3-5

The steps performed in this Pictorial are in this area of the circuit board.

IDENTIFICATION DRAWING



PART NUMBER

START ◀

NOTE: When you install the following transistors, line up the tab on each transistor with the outline of the tab on the circuit board. Then insert the leads into their correct C, B, and E holes. Solder the leads to the foil and cut off the excess lead lengths.

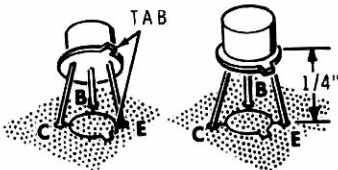

Two 2N2369 transistors (#417-154) at:

- () Q405.
- () Q406.

Q407: 2N3866 transistor (#417-205). This transistor fits down against the circuit board.

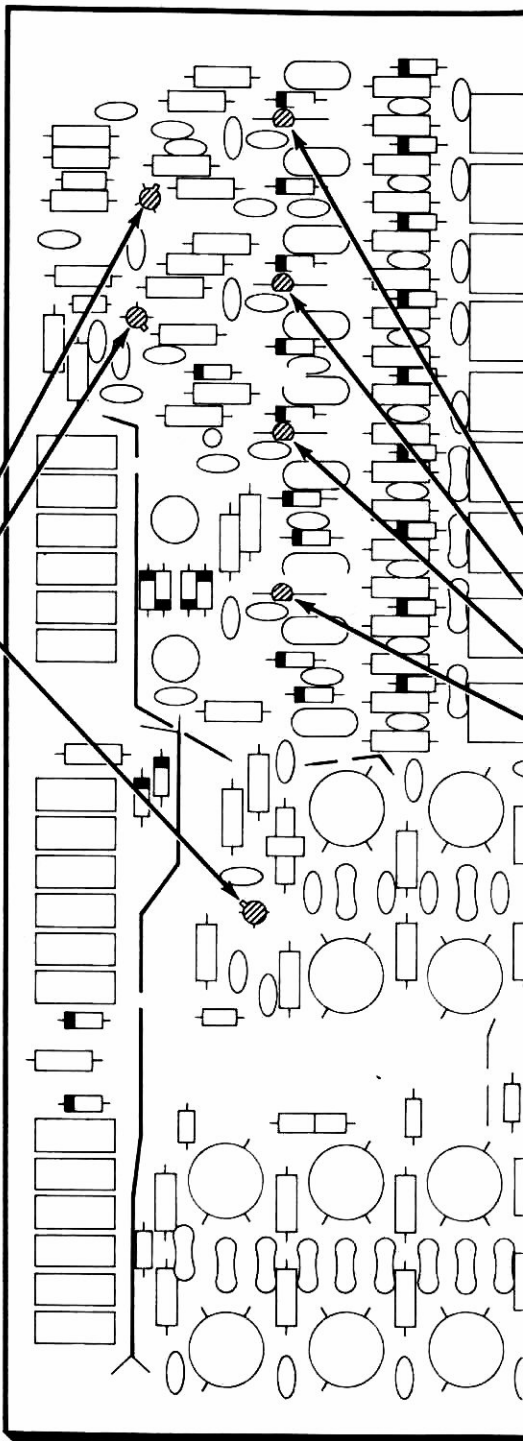

CONTINUE ▶

NOTE: Install the following transistors in the manner shown. First line up the flat of the transistor with the outline of the flat on the circuit board. Insert the transistor leads into their correct holes indicated by E, B, and C. Solder each lead to the foil and cut off the excess lead length.

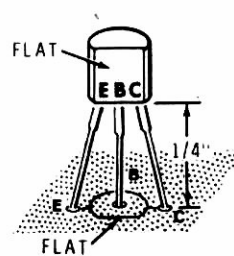

Four MPS 6521 transistors (#417-172) at:

- () Q404.
- () Q403.
- () Q402.
- () Q401.

PICTORIAL 3-6

The steps performed in this Pictorial are in this area of the circuit board.

IDENTIFICATION DRAWING



PART NUMBER

START

- () C428: 5 pF disc.
- () C429: 10 pF disc.
- () C431: 10 pF disc.
- () C437: 100 pF disc.
- () C439: 100 pF disc.
- () C441: 33 pF disc.
- () C421: 5 pF disc.
- () C422: 10 pF disc.
- () C443: .001 μ F disc.
- () C444: 2.7 pF disc.
- () Solder the leads to the foil and cut off the excess lead lengths.
- () C423: 10 pF disc.
- () C414: 18 pF disc.
- () C413: 5 pF disc.
- () C416: 10 pF disc.
- () C404: 10 pF disc.
- () C446: .001 μ F disc.
- () C403: 5 pF disc.
- () C407: 3.3 pF disc.
- () RFC 403: 30 μ H inductor (#45-27). Bend the leads toward the slot in the coil form to prevent damage to the leads of the winding.
- () Solder the leads to the foil and cut off the excess lead lengths.

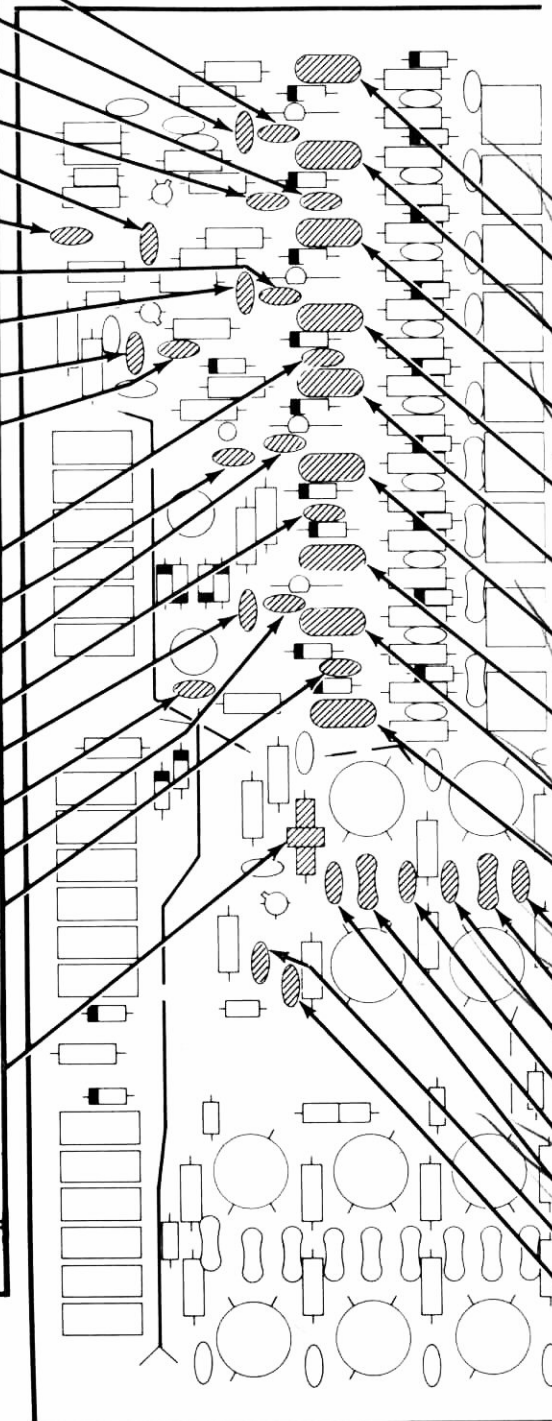
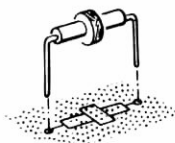

CONTINUE

NOTE: Each crystal frequency is screened on the circuit board. The component numbers are also screened except for Y403, Y405, and Y407. Be sure you mount each crystal in its correct location. Use a minimum amount of heat and solder the leads to the foil.



- () Y409: 38.395 MHz crystal (#404-422).
- () Y408: 37.895 MHz crystal (#404-421).
- () Y407: 37.395 MHz crystal (#404-420).
- () Y406: 36.895 MHz crystal (#404-419).
- () Y405: 29.895 MHz crystal (#404-418).
- () Y404: 23.895 MHz crystal (#404-543).
- () Y403: 22.895 MHz crystal (#404-417).
- () Y402: 15.895 MHz crystal (#404-416).
- () Y401: 12.395 MHz crystal (#404-415).
- () C469: 6 pF disc.
- () C471: 33 pF mica.
- () C472: 6 pF disc.
- () C474: 5 pF disc.
- () C475: 33 pF mica.
- () C476: 5 pF disc.
- () C449: .1 μ F disc.
- () C447: 270 pF disc.
- () Solder the leads to the foil and cut off the excess lead lengths.

PICTORIAL 3-7

The steps performed in this Pictorial are in this area of the circuit board.

IDENTIFICATION DRAWING

PART NUMBER



START

NOTE: As you install the components in this pictorial, solder the leads and cut off the excess lead lengths.



() RFC 402: 2.2 μ H inductor (#45-73).

() RFC 401: 2.2 μ H inductor (#45-73).

WIDE RIDGE

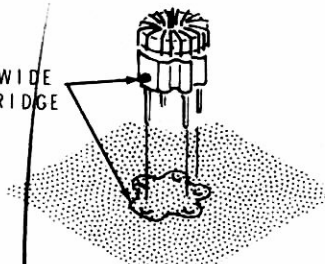

() L422, L423: Two transformers (#40-1050). Match the wide ridge on the coil form to the wide space between the dots on the circuit board outline.

() L410-L415: Six 7.95 μ H coils (#40-1672).

After you install the coils, connect a diode between lugs 1 and 3 of each coil. Be sure you position the banded end of the diode as shown in the Pictorial (toward lug 1 of the coil). Use your soldering iron to remove any excess wax from the lugs before you install the diode. Bend each diode lead against a coil terminal and solder it in place. Then cut off the excess lead lengths.

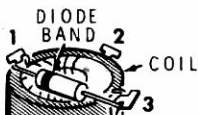

() D431-D436: Six 1N458 diodes (#56-24). Connect them to coils L410-L415 respectively.

CONTINUE

Position each coil over its outline and insert all four pins through their holes. Make sure no terminals of adjacent coils touch each other. Then solder the coil pins to the foil.

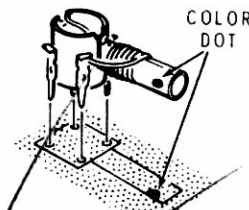

() L402-L409: Eight coils (#40-687, green dot).

() L401: 1.42 μ F coil (#40-1047, gray dot).

() L416-L421: Six 3.975 μ H coils (#40-1879, red dot).

After installing the coils, connect a diode between lugs 1 and 3 of each coil. Be sure you position the banded end of the diode as shown in the Pictorial. Bend each diode lead against a coil terminal and solder it in place. Cut off the excess lead lengths.

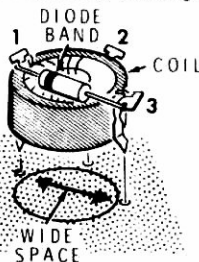

() D437-D442: Six 1N458 diodes (#56-24). Connect them to coils L416-L421 respectively.

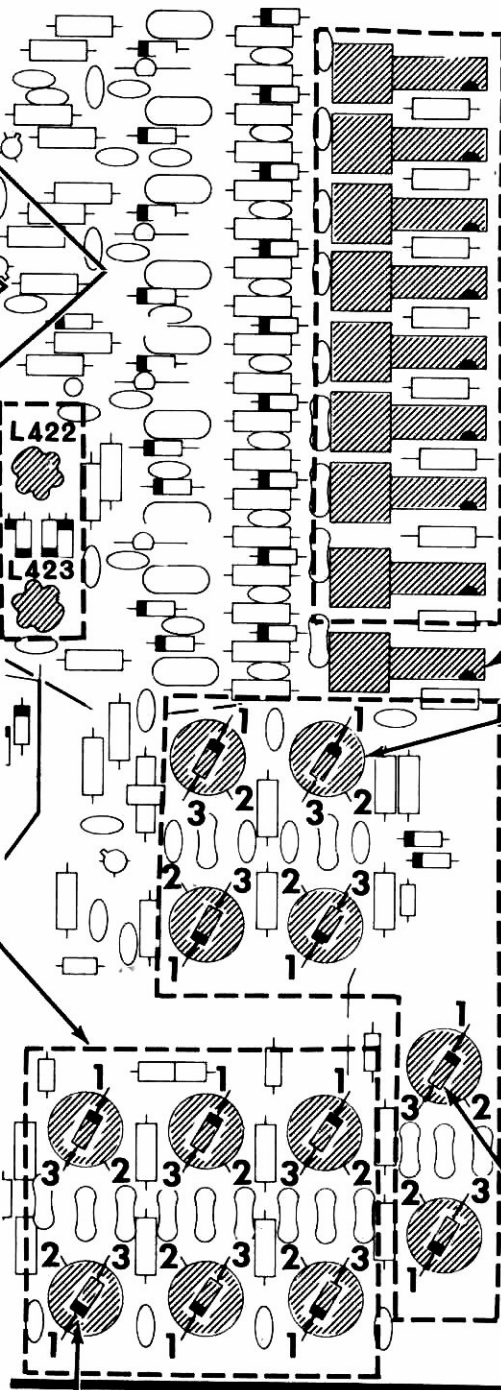

PICTORIAL 3-8

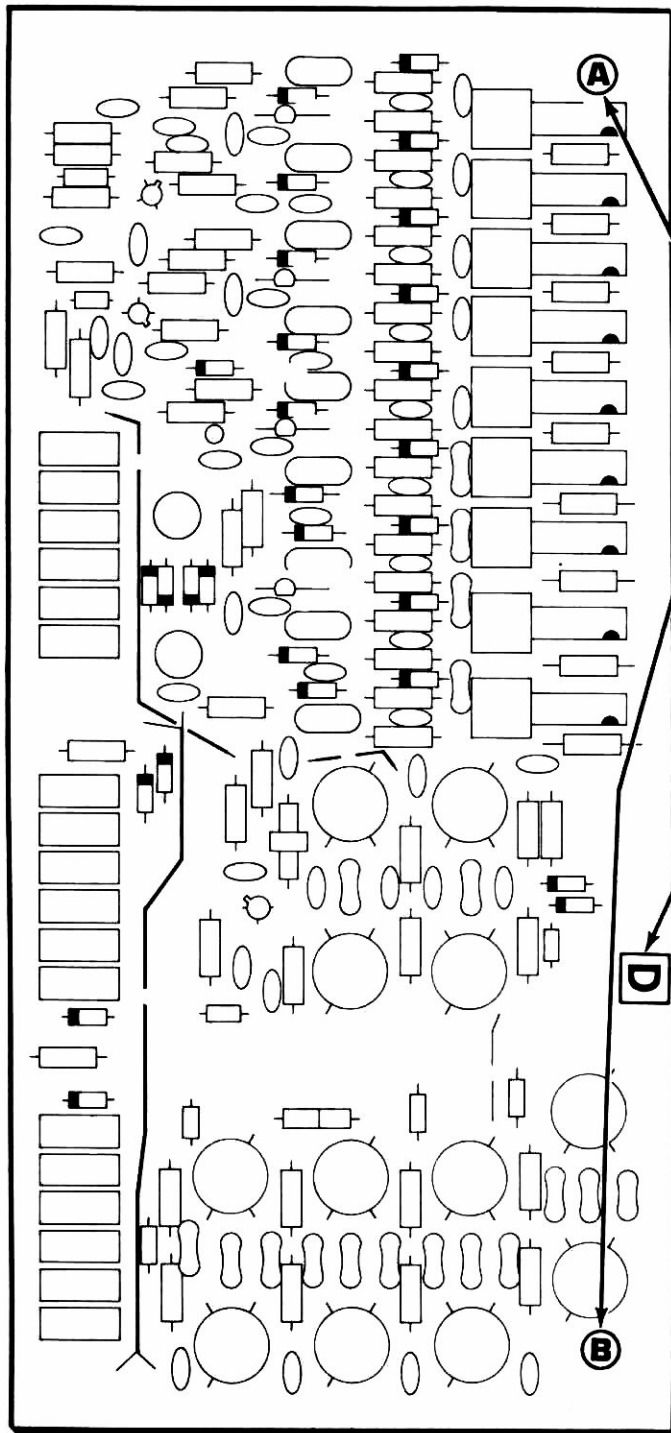

START →

- () Mount board pullers on the foil side of the circuit board at holes A and B. Position the female part in the circuit board; then push the male part through the female part.

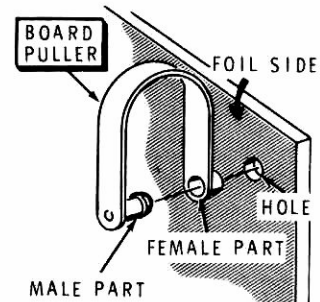

- () Cut a letter "D" from the terminal identification sheet and remove the adhesive backing. Press the letter onto the circuit board at the location shown.

CIRCUIT BOARD CHECKOUT

Carefully inspect the circuit board for the following conditions.

- () Unsoldered connections.
- () "Cold" solder connections.
- () Solder bridges between foil patterns.
- () Protruding leads which could touch together.
- () Transistors for the proper type and installation.
- () Diodes for the correct position of the banded end.

Temporarily set the circuit board aside.

FINISH

PICTORIAL 3-9

CONVERTER, DISPLAY, AND COUNTER CIRCUIT BOARDS

PARTS LIST

Remove the parts from pack #4 and check each part against the following list. Make a check (✓) in the space provided as you identify each part. Any part that is packed in an individual envelope with the part number on it should be placed back in the envelope after you identify it until it is called for in a step. Do not throw away any packing materials until all parts are accounted for.

QTY.	DESCRIPTION	HEATH No.	CIRCUIT Component No.
RESISTORS 1/4-Watt			
() 6	2200 Ω (red-red-red)	6-222-12	R151-R156
() 6	10 kΩ (brown-black-orange)	6-103-12	R157-R163
() 1	470 kΩ (yellow-violet-yellow)	6-474-12	R164
1/2-Watt			
() 2	56 Ω (green-blue-black)	6-560	R851, R852
() 1	150 Ω (brown-green-brown)	6-151	R112
() 8	220 Ω (red-red-brown)	6-221	R104-R109, R853, R854
() 2	680 Ω (blue-gray-brown)	6-681	R111, R113
() 2	1000 Ω (brown-black-red)	6-102	R101, R103
() 1	3900 Ω (orange-white-red)	6-392	R102

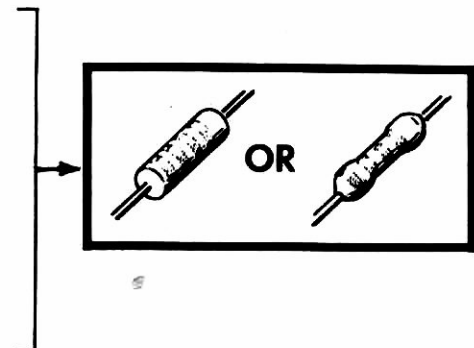
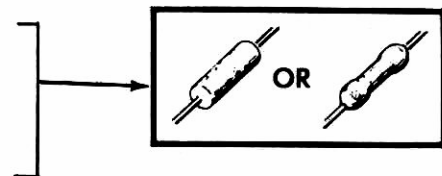

QTY.	DESCRIPTION	HEATH No.	CIRCUIT Component No.
------	-------------	-----------	-----------------------

CAPACITORS

Disc

()	1	5 pF	21-78	C113
()	1	.005 μ F	21-46	C112
()	1	.02 μ F	21-31	C856
()	13	.1 μ F	21-95	C101, C103- C109, C111, C853, C854, C857, C858

Other Capacitors

()	1	2-8 pF trimmer	31-62	C114
()	1	36 pF mica	20-96	C102
()	2	.001 μ F feedthrough	21-145	C851, C855
()	1	100 μ F electrolytic	25-56	C852

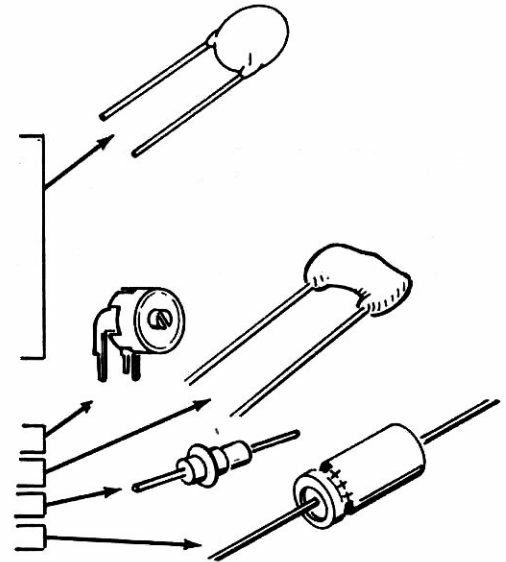

NOTE: HEATH PART NUMBERS ARE STAMPED ON MOST DIODES.

DIODES-TRANSISTORS

()	10	1N4149 silicon diode	56-56	D101-D110
()	4	1N2071 silicon diode	57-27	D851-D854
()	1	2N2369 transistor	417-154	Q101
()	2	MPSU05 transistor	417-224	Q851, Q852

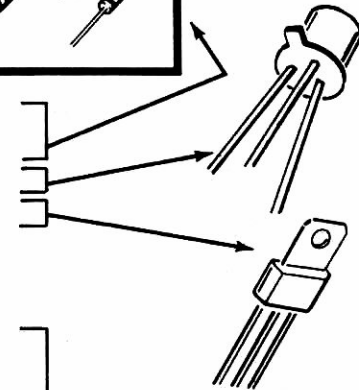

INTEGRATED CIRCUITS

()	1	SN7400N	443-1	IC112
()	1	SN7420N	443-2	IC119
()	2	SN7473N	443-5	IC117 IC118
()	4	SN7490N	443-7	IC113, IC114 IC115, IC116
()	5	SN7475N	443-13	IC103, IC105, IC107, IC109, IC111
()	1	SN74H103	443-70	IC101
()	6	DD700 (DM8880) decoder	443-602	IC151-IC156
()	5	74196	443-628	IC102, IC104, IC106, IC108, IC110

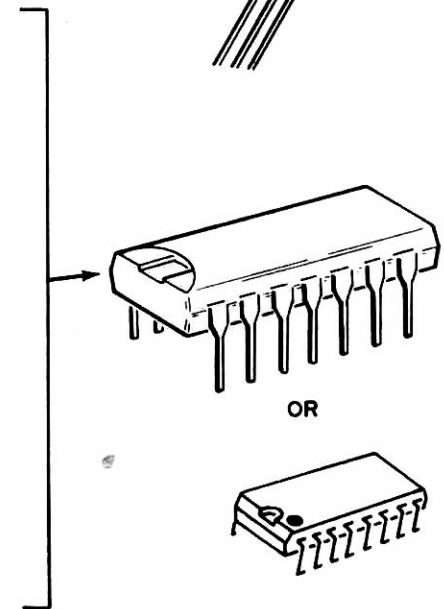

QTY.	DESCRIPTION	HEATH No.	CIRCUIT Component No.
MISCELLANEOUS			
() 1	3 μ H toroid coil	40-958	L851
() 1	Transformer	54-861	T851
() 2	Shield	200-661	

() 1	Shield top	205-1430	
() 3	SP-352 display tube	411-295	V151-V153
() 26	Male connector	432-121	
() 24	Circuit board connector	432-124	

() 49	Wire socket	432-134	
() 14	14-pin socket	434-298	
() 11	16-pin socket	434-299	
() 1	Phono socket	434-186	J101

() 2	Board puller	207-80	
() 1	Crystal	404-424	Y101
() 21	Ferrite bead	475-10	
() 4	#6 x 3/8" screw	250-8	

PARTS FROM PACK #10

() 1	Converter circuit board	85-1415-1	
() 1	Display circuit board	85-1416-1	
() 1	Counter circuit board	85-1417-2	

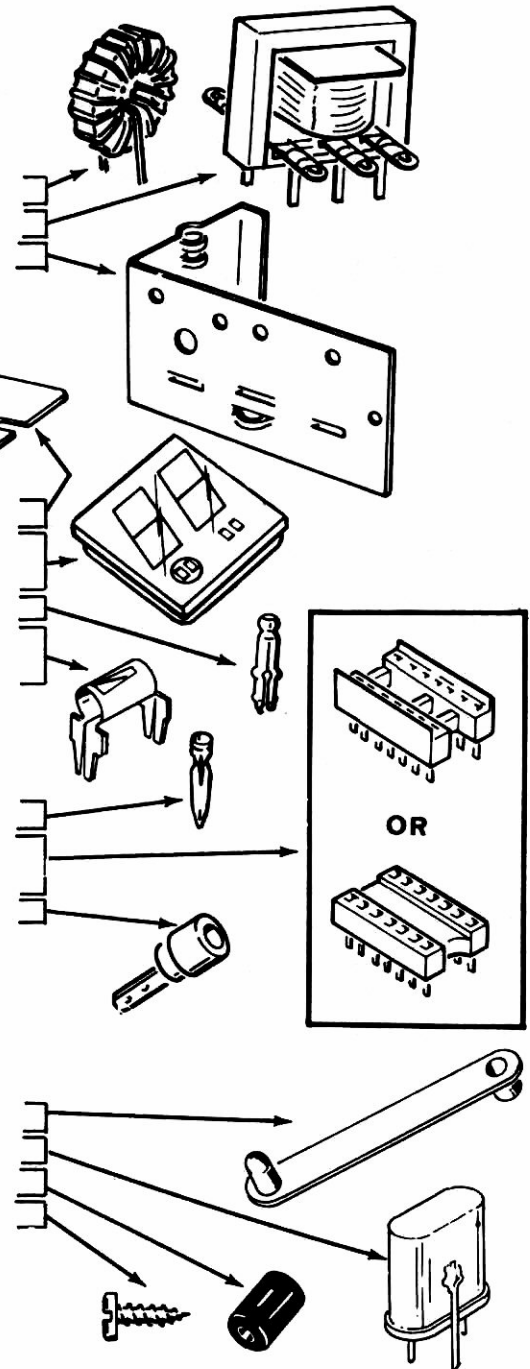

To order a replacement part, always include the PART NUMBER. Use the Parts Order Form furnished with this kit. If one is not available, see "Replacement Parts" inside the rear cover of this Manual. Your Warranty is located inside the front cover. For pricing information, refer to the separate "Heath Parts Price List."

STEP-BY-STEP ASSEMBLY

CONVERTER CIRCUIT BOARD

START

Position the converter circuit board (#85-1415-1) as shown.

() R852: 56 Ω (green-blue-black).

() R851: 56 Ω (green-blue-black).

() R853: 220 Ω (red-red-brown).

() R854: 220 Ω (red-red-brown).

NOTE: When you install a diode, always match the banded end on the diode with the band mark on the circuit board.



() D851-D854: Four 1N2071 (#57-27) diodes.

() Solder the leads to the foil and cut off the excess lead lengths.

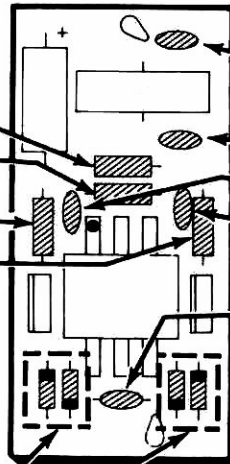

CONTINUE

Install four .1 μ F disc capacitors at:

() C853.

() C854.

() C857.

() C858.

() C856: .02 μ F disc.

FOR GOOD SOLDER CONNECTIONS, YOU MUST KEEP THE SOLDERING IRON TIP CLEAN.

WIPE IT OFTEN WITH A DAMP SPONGE OR CLOTH.



() Solder the leads to the foil and cut off the excess lead lengths.

PICTORIAL 4-1

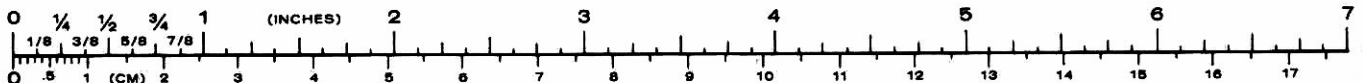

START

NOTE: Before you install an electrolytic capacitor, look at it and identify the leads. One lead will have a plus (+) mark or a minus (-) mark near it. Be sure to install the positive lead in the positive marked hole. Be careful; only the negative lead may be marked.

IDENTIFIED LEAD IS NEGATIVE (-)

IDENTIFIED LEAD IS POSITIVE (+)

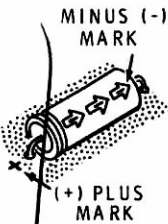

() C852: 100 μ F electrolytic.

NOTE: To install this transistor, position it with the beveled corners as shown in the Pictorial. Insert the leads into the holes so the body is 1/4" from the circuit board and solder each lead to the foil. Cut off the excess lead lengths.

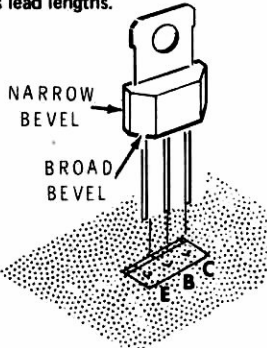

() Q851: MPSU05 transistor (#417-224).

() Q852: MPSU05 transistor (#417-224).

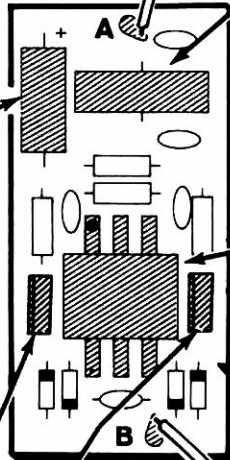

CONTINUE

() Prepare a 2" small orange wire. Solder one end of the wire to the foil and cut off the excess wire end.

() L851: Insert the 3 mH coil leads (#40-958) into the circuit board holes. Solder the leads to the foil and cut off the excess lead lengths.



T851: Match the transformer colored lug to the dot on the circuit board and insert the lugs in the holes. Solder the lugs to the foil and cut off the excess lead lengths.

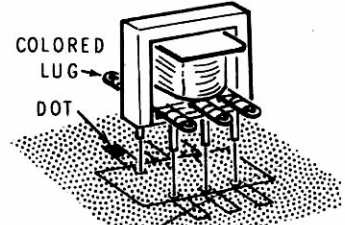

() Prepare a 2" small orange wire. Solder one end of the wire to the foil and cut off the excess wire end.

CIRCUIT BOARD CHECKOUT

Carefully inspect the circuit board for the following conditions.

- () Unsoldered connections.
- () "Cold" solder connections.
- () Solder bridges between foils.
- () Protruding leads. No lead should be longer than 1/8".
- () Transistors for the proper type and installation.
- () Electrolytic capacitor for the correct position of the positive (+) end.
- () Diodes for the correct position of the banded end.

PICTORIAL 4-2

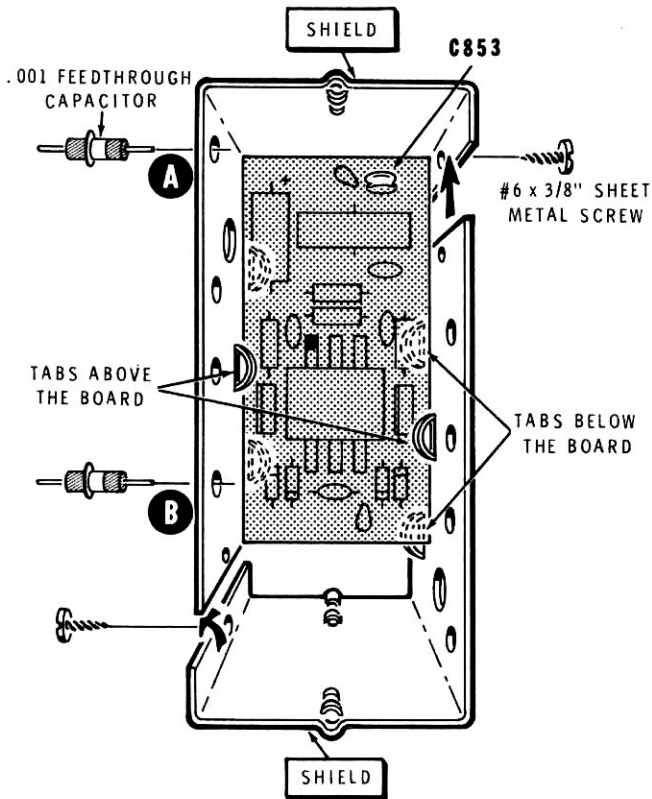

PICTORIAL 4-3

Refer to Pictorial 4-3 for the following steps.

- () Position the converter circuit board between the retaining tabs of both shields and assemble the shield with two #6 x 3/8" screws. These two sides are symmetrical.

NOTE: If one of the sheet metal screws is touching disc capacitor C853, bend the capacitor away from the screw.

- () Cut the leads of two .001 μ F feedthrough capacitors to 1/8" from the ceramic.
- () C851: From the outside of the shield box, install a .001 μ F feedthrough capacitor in hole A. Solder the metal collar of the capacitor to the shield box.
- () C855: Similarly, install and solder a .001 μ F feedthrough capacitor in hole B in the shield box.

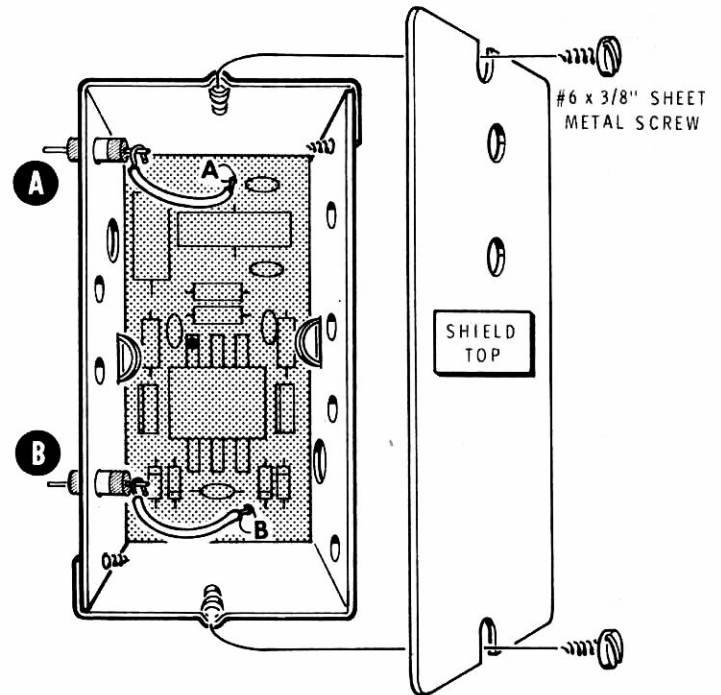

PICTORIAL 4-4

Refer to Pictorial 4-4 for the following steps.

CAUTION: Do not place any strain on the feedthrough capacitors, as the ceramic insulation can be damaged.

- () Connect the wire coming from circuit board hole A to the capacitor lead at hole A (S-1).
- () Connect the wire coming from circuit board hole B to the capacitor lead at hole B (S-1).
- () On the foil side of the circuit board, scrape a little of the blue coating off the board at each retaining tab. Then solder each of the four tabs to the foil.
- () Mount the shield top to the shield box with two #6 x 3/8" screws. Disregard the two unused holes.

Set the assembly aside until called for in a step.

DISPLAY CIRCUIT BOARD

START 

NOTE: This circuit board has foil on both sides. As with the other circuit boards, the "foil side" referred to on these pages is the side WITHOUT the printed component outlines. Solder ONLY to this side of this circuit board.

Position the display circuit board (#85-1416-1) as shown.

Install six 2200 Ω , 1/4-watt, (red-red-red) resistors at:

- () R156.
- () R155.
- () R154.
- () R153.
- () R152.
- () R151.

() R164: 470 k Ω , 1/4-watt (yellow-violet-yellow).

() Solder the leads to the foil and cut off the excess lead lengths.

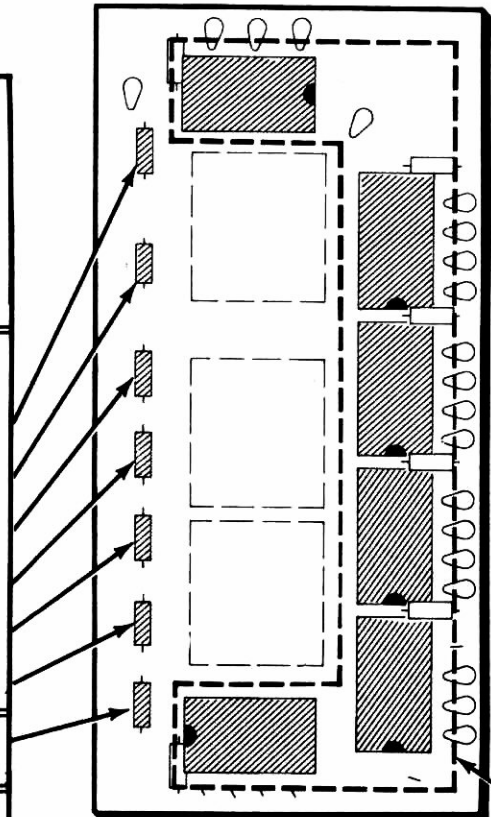

PICTORIAL 4-5

CONTINUE 

NOTE: Both 14-pin and 16-pin dual-in-line IC's and sockets are used in this kit. Be very careful when you install the sockets, as it is possible to accidentally place a 14-pin socket in a 16-pin socket location.

If the 16-pin IC sockets furnished are of two different sizes, use the smaller 16-pin sockets on this circuit board.

Insert the socket pins into the holes. The half-moon mark on the circuit board should still be visible after it is installed. Solder the pins to the foil.

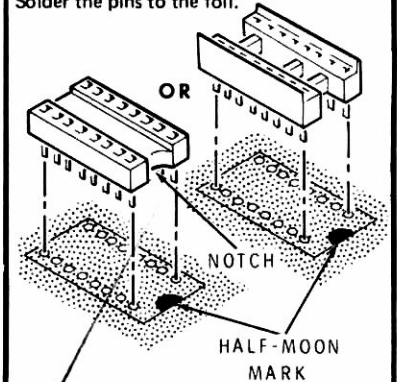

Install six 16-pin IC sockets at IC151-IC156. Make sure all the pins are in their holes and that the body of each socket is flat against the circuit board. Solder all the pins of each socket to the foil as you install it.

KEEP YOUR
SOLDERING
IRON TIP
CLEAN

START

In the following steps, install six 10 kΩ, 1/4-watt resistors (brown-black-orange). If you installed the large size IC sockets, the 10 kΩ resistors may not fit down on the circuit board. In this case, install the 10 kΩ resistors vertically in the holes indicated by the arrowheads, with the other lead bent over and installed as shown below.

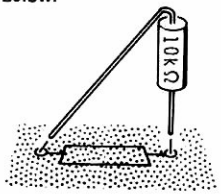

- () R163
 - () R162
 - () R161
 - () R159
 - () R158
 - () R157
- () Solder the leads to the foil and cut off the excess lead lengths.

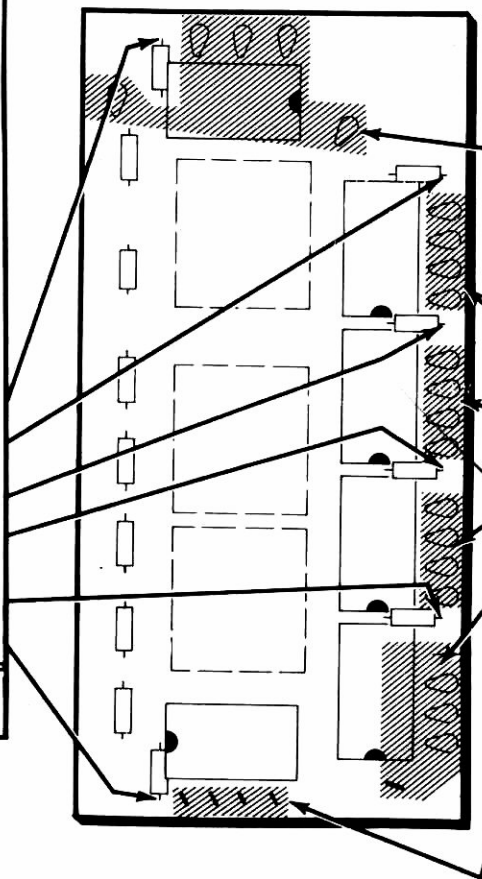

CONTINUE

NOTE: In the following steps, install male connectors (#432-121) in the holes as shown. Push the connectors into the holes until the stop ridge is firmly down against the circuit board. Then solder the connectors to the foil. At the lettered locations within the shaded areas for each step.

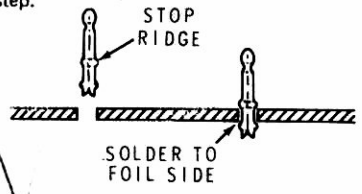

- () Five male connectors.
- () Four male connectors.
- () Four male connectors.
- () Four male connectors.
- () Five male connectors.
- () Four male connectors.

PICTORIAL 4-6

START ▼

In the following steps, install six IC's in the designated sockets. See Detail 4-7A below. Be careful to match the pin 1 end of each IC to the half-moon mark on the circuit board.

NOTE: Before you install an IC, first be sure the pins are straight. Then lay it down on one of its rows of pins, as shown below at A, and roll it over until the pins are at right angles or are bent in slightly as shown at B. Repeat this process for the other row of pins.



Before you apply downward pressure to an IC, make sure each IC pin is centered in its proper socket aperture. Handle IC's carefully as their pins are easily bent.

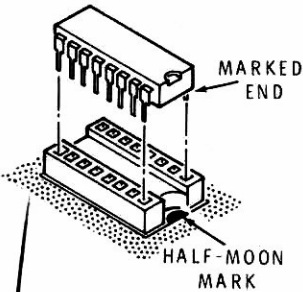

() IC151 through IC156: DD700 or DM8880 IC (#443-602).

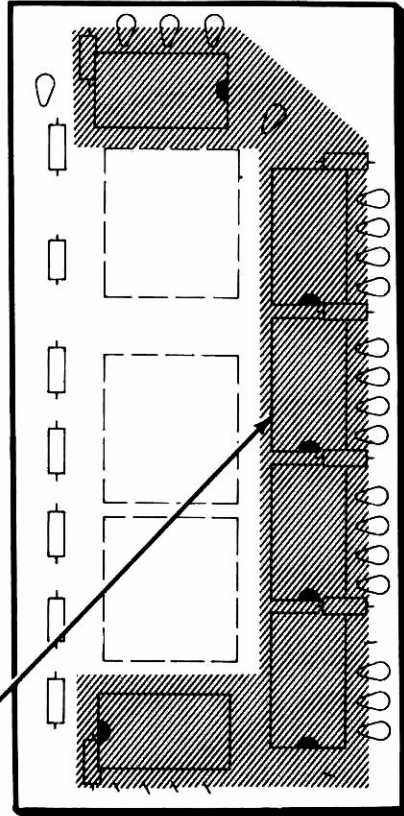

PICTORIAL 4-7

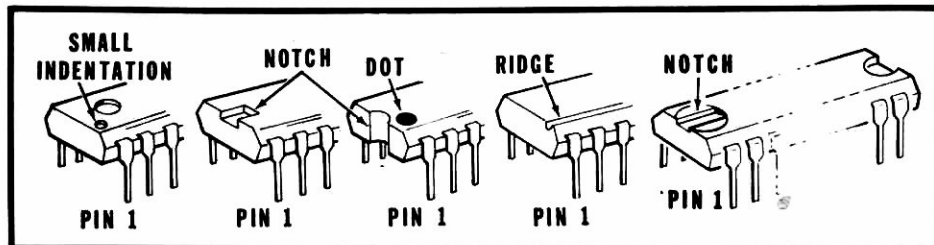

Detail 4-7A

START

Prepare two display tubes as follows:

- () Position two display tubes with their pins up and with the glass seal positioned as shown below. It may be necessary to straighten the pins. Carefully select pins A8, A10, B8, and B10, and bend these pins over against the tube base. Do not permit these pins to touch any other pin.

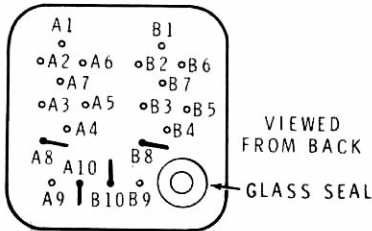

- () Use thin-nose pliers to hold a wire socket with its open end down. Push the wire socket down onto a tube pin until it touches the back of the tube. As the tube pins are easily bent, you must very carefully push straight down with just enough force to cause the pin to enter the wire socket. If the tube pin bends, straighten it and try again.

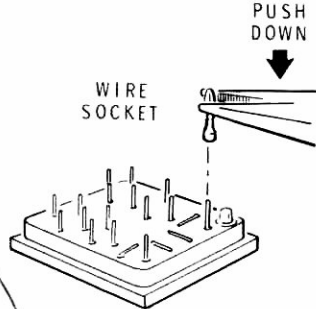

- () Install wire sockets on all of the unbent pins of the two display tubes.

- () Look at the wire sockets of each tube from two adjacent sides and adjust the sockets so they are parallel and are perpendicular to the back of the tube. Make sure there is no contact with the bent pins.

- () **TURN THE CIRCUIT BOARD FOIL-SIDE-UP** in the position shown in the Pictorial.

FOR GOOD SOLDER CONNECTIONS, YOU MUST **KEEP THE SOLDERING IRON TIP CLEAN.**

WIPE IT OFTEN WITH A DAMP SPONGE OR CLOTH.

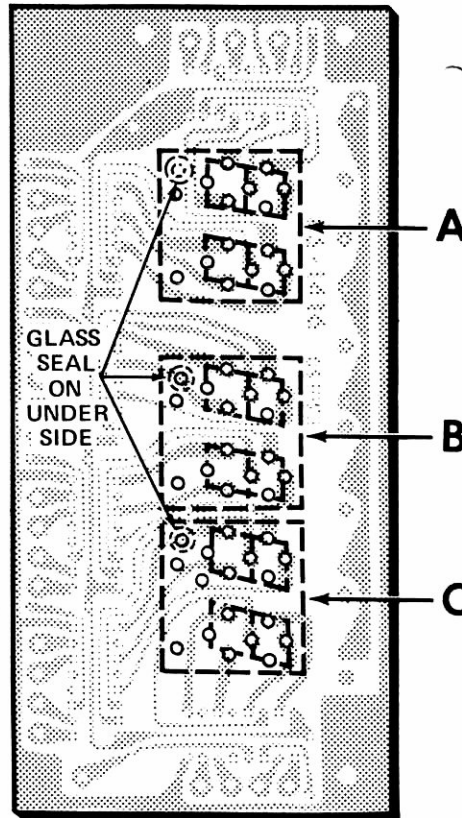

PICTORIAL 4-8

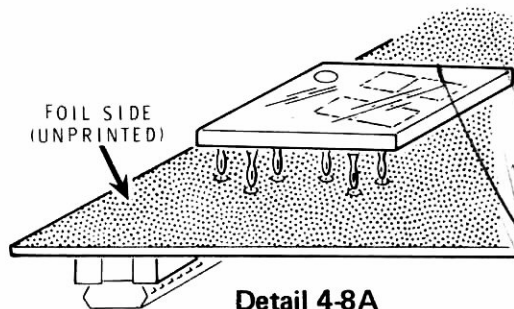

Detail 4-8A

CONTINUE

- () V153: At location A in the Pictorial, hold a display tube with the wire sockets toward the foil side of the circuit board as shown in Detail 4-8A. Position the glass seal (on the under side of the tube) as shown in the Pictorial. Then carefully fit the wire sockets into the circuit board holes. Push the tube into the board as far as possible.

- () V152: In the same manner, fit the second display tube into the circuit board at location B.

- () Prepare the remaining display tube by bending down pins A8, A10, and B10. **DO NOT** bend pin B8 over. (This is the pin for the decimal point in the display.)

- () Install wire sockets on the 17 unbent pins of this display tube.

- () V151: In the same manner as before, fit the third display tube into the circuit board holes at location C.

- () Check to see that the faces of all three display tubes are aligned with each other.

- () Carefully turn the circuit board over so the **FOIL SIDE** is down. The circuit board will rest on the tube faces, so use a soft cloth on your work table.

- () Solder all wire sockets to the **COMPONENT** (printed) side of the circuit board. **CAUTION:** Use a **MINIMUM** amount of heat and solder at each wire socket, but be sure you have a good connection. If you hold the soldering iron on the connection too long, or use too much solder, the solder may "wick up" inside the wire socket and solder the tube pin to the socket. This creates a problem if it ever becomes necessary to replace the tube.

CIRCUIT BOARD CHECKOUT

Carefully inspect the circuit board for the following conditions.

- () Unsoldered connections.
- () "Cold" solder connections.
- () Solder bridges between foil patterns.
- () Protruding leads which could touch together.
- () Integrated circuits for the proper type and installation.

FINISH

COUNTER CIRCUIT BOARD

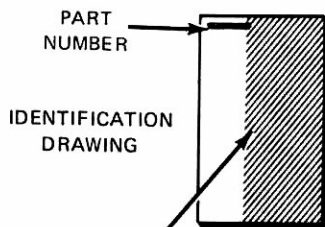

The steps performed in this Pictorial are in this area of the circuit board.

START

NOTES:

1. Only part of the circuit board is shown in the following Pictorials. An identification drawing at the top of each Pictorial shows the area of the circuit board to be assembled.
2. In the Pictorial drawings, a dashed line may designate the work area for a specific step.

Position the counter circuit board (#85-1417-2) as shown in the identification drawing. Then complete each step on the Pictorials.

() Cut eight 1-3/8" lengths of small bare wire.

() Connect these wires to jumper each of the indicated "J" positions. Keep these wires flat against the circuit board.

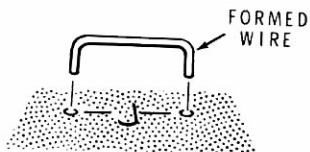

FOR GOOD SOLDER CONNECTIONS, YOU MUST KEEP THE SOLDERING IRON TIP CLEAN... Wipe it often with a damp sponge or cloth.



() Solder each wire end to the foil and cut off the excess lead lengths. Be sure you solder sixteen connections.

() Cut six 1-3/8" lengths of small bare wire.

() Connect five of these wires to jumper each of the indicated "J" positions.

() One 1-3/8" bare wire.

() Solder each wire end to the foil and cut off the excess lead lengths.

CONTINUE

() One 1-3/8" bare wire jumper.

NOTES:

1. When you install a diode, always match the banded end on the diode with the band mark on the circuit board.
2. In the following step, the foils are very close together and you must guard against solder bridges. To check for solder bridges, hold the circuit board closely against a strong light. You can then easily see whether the spaces between foils are clear. You can also use a magnifying glass to inspect the areas between foils. If you do get a solder bridge, melt the solder and let it run down on the soldering iron, or brush off the melted solder with a small brush or a rag.



() D101-D110: Ten IN4149 diodes (#56-56).

() Solder all leads to the foil and cut off the excess lead lengths.

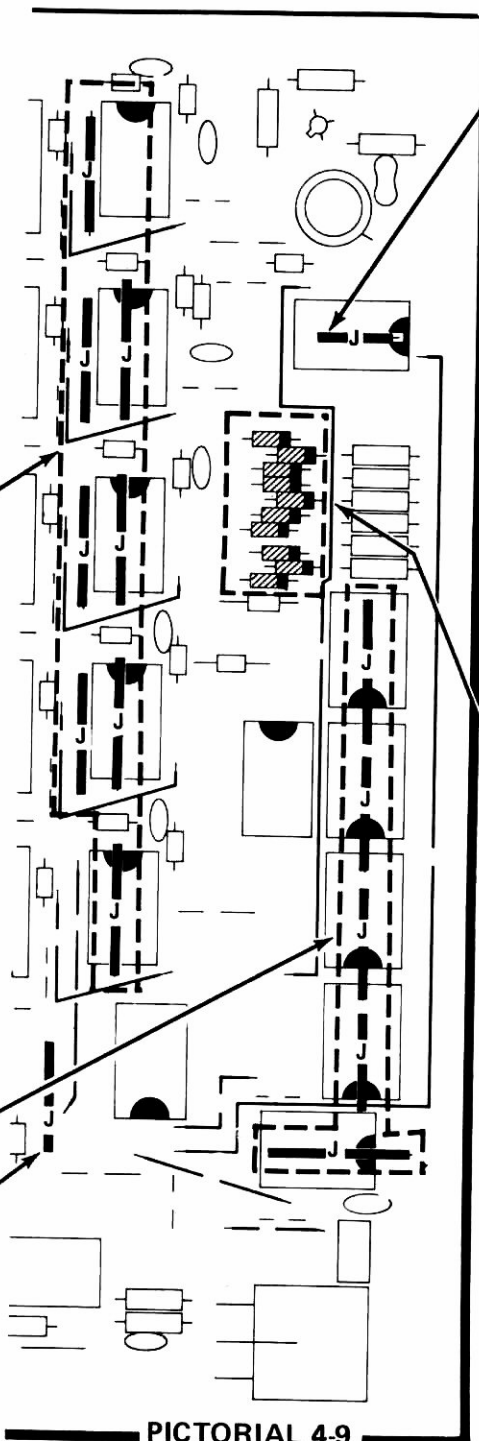

PICTORIAL 4-9

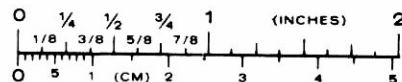

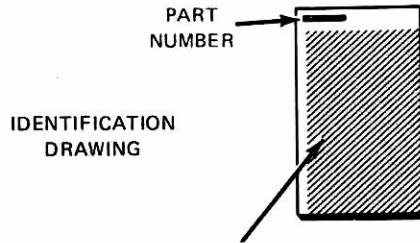

The steps performed in this Pictorial are in this area of the circuit board.

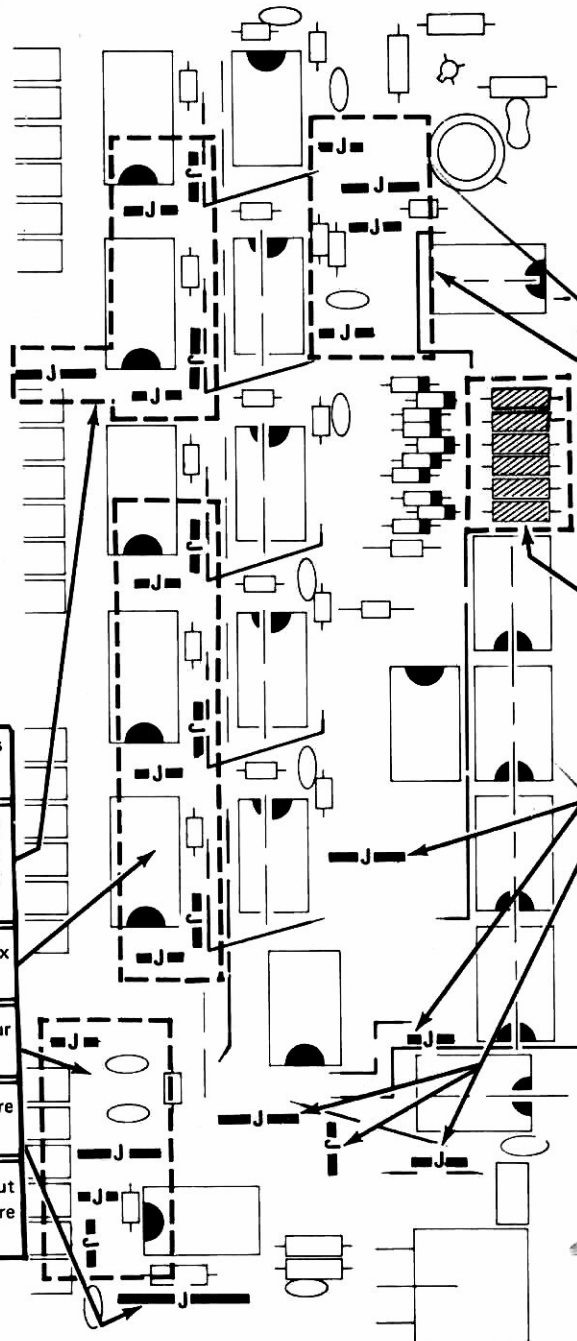

START

NOTE: Solder the wires and jumpers as they are installed in the following steps.

- () Cut five 1" small bare wires and connect them as short jumper wires across the "J" positions within the boxed area.
- () In a similar manner, connect six jumpers.
- () In a similar manner, connect four jumpers.
- () One 1-3/8" length of small bare wire.
- () Solder all leads to the foil and cut off the excess lead lengths. Be sure you solder all connections.

CONTINUE

- () Connect four short bare wire jumpers.
- Six 220 Ω (red-red-brown):
- () R108.
- () R107.
- () R109.
- () R105.
- () R104.
- () R106.
- () Connect two bare wire jumpers.
- () Connect three bare wire jumpers.
- () Solder all leads to the foil and cut off the excess lead lengths. Be sure you solder all connections.

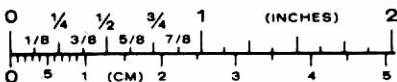

PICTORIAL 4-10

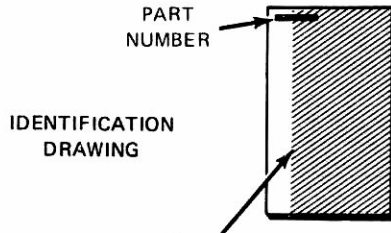

The steps performed in this Pictorial are in this area of the circuit board.

START ↘

NOTE: To install a ferrite bead, push a 1" length of small bare wire through the bead and bend down the wire ends as shown. Solder each group of beads as it is installed.



- () Install eight ferrite beads, one at each FB position within the indicated area.
- () Solder all leads to the foil and cut off the excess lead lengths. Be sure you solder all connections.
- () In a similar manner, install eight ferrite beads.
- () Solder all leads to the foil and cut off the excess lead lengths. Be sure you solder all connections.
- () In a similar manner, install five ferrite beads.
- () Solder all leads to the foil and cut off the excess lead lengths. Be sure you solder all connections.

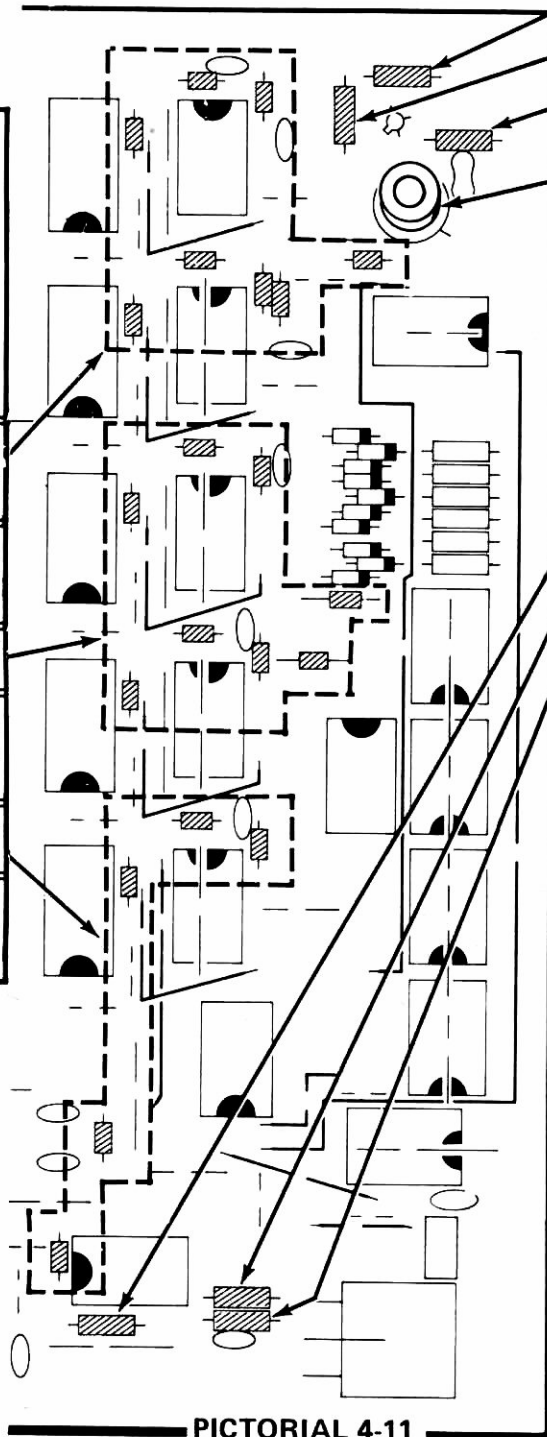

CONTINUE ↘

- () R102: 3900 Ω (orange-white-red).
 - () R101: 1000 Ω (brown-black-red).
 - () R103: 1000 Ω (brown-black-red).
 - () J101: Phono socket.
-
- BEND THE LUG TOWARD THE INDICATED HOLE. DO NOT SOLDER THE LUG YET.
- () R113: 680 Ω (blue-gray-brown).
 - () R112: 150 Ω (brown-green-brown).
 - () R111: 680 Ω (blue-gray-brown).
 - () Solder all leads to the foil and cut off the excess lead lengths.

PICTORIAL 4-11

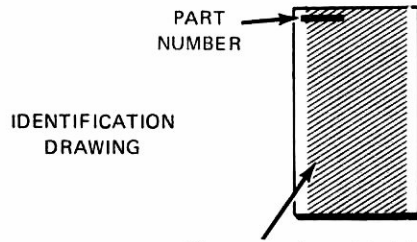

The steps performed in this Pictorial are in this area of the circuit board.

START ▾

NOTES:

- Several IC sockets will be installed over wire jumpers in the following steps. Make sure each wire is flat against the circuit board and does not elevate the socket. Before you start to solder each socket, count the pins on the foil side of the circuit board to make sure they all extend through the circuit board.
- Insert the socket pins into the holes. The half-moon mark on the circuit board should still be visible after it is installed. Solder the pins to the foil.

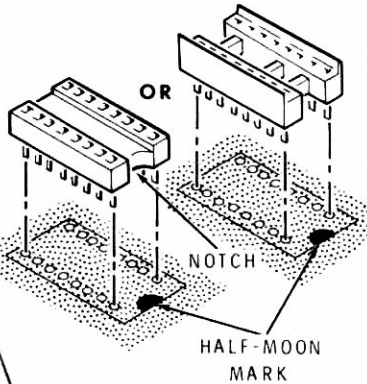

() Install five 16-pin IC sockets. Be sure the sockets are tight against the circuit board.

() Install one 14-pin IC socket.

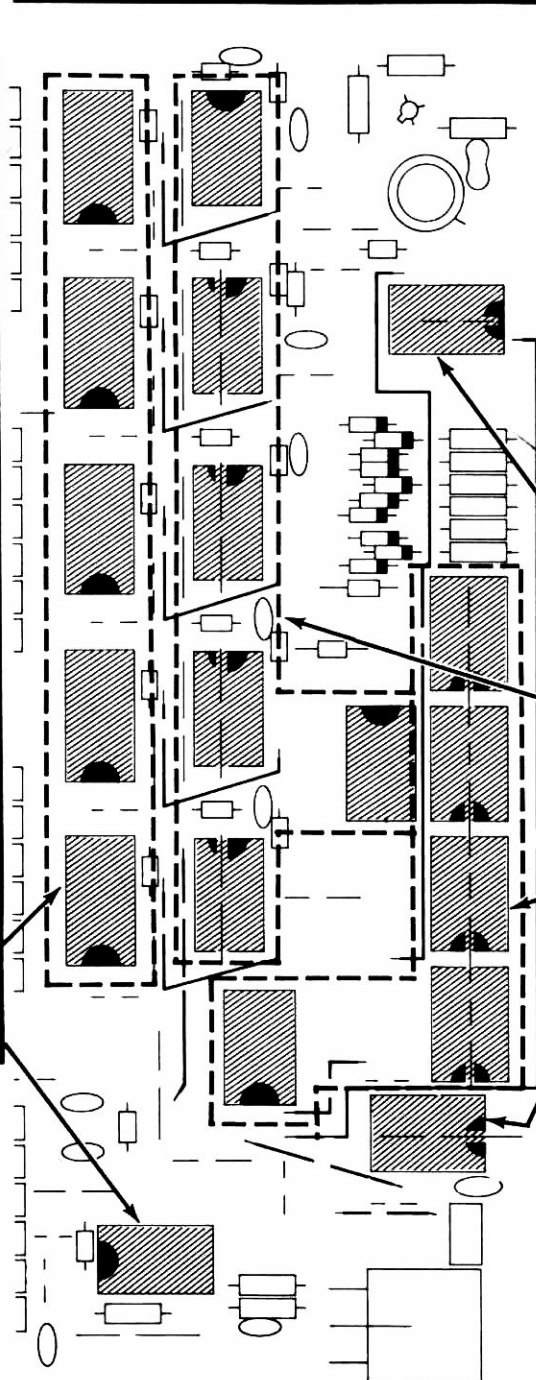

CONTINUE ▾

() Install one 14-pin IC socket.

() Install six 14-pin IC sockets.

() Install five 14-pin IC sockets.

() Install one 14-pin IC socket.

CONTINUE

- () 5-1/2" wire.
- () 7-1/2" wire.
- () Solder all wires to the foil and cut off the excess wire lengths.

START

1) Install twenty-four circuit board connectors in the following manner. Note that inside each connector the spring contact is depressed on one end. This depressed end of the connector should face away from the edge of the circuit board. Insert the mounting tabs through the circuit board until the ridges of the connector are firmly against the circuit board. Look at the row of connectors to make sure the depressed end of the contact of each connector is toward the center of the circuit board. Solder the tabs to the foil.

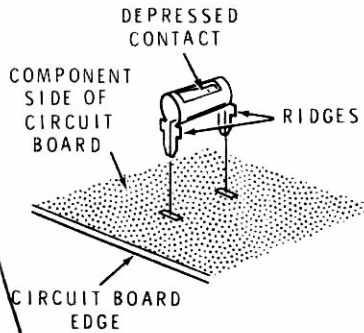

- () Prepare six 2" lengths of gray wire.
- () Install these wires at the indicated "J" locations with the heavy lines. Remove additional insulation as necessary for a neat appearance.
- () Prepare two 1-1/2" lengths and one 1-1/8" length of gray wire.
- () One 1-1/2" wire.
- () One 1-1/2" wire.
- () One 1-1/8" wire.
- () Prepare one 5-1/2" and one 7-1/2" lengths of gray wire.
- () Proceed to the three steps in the right column.

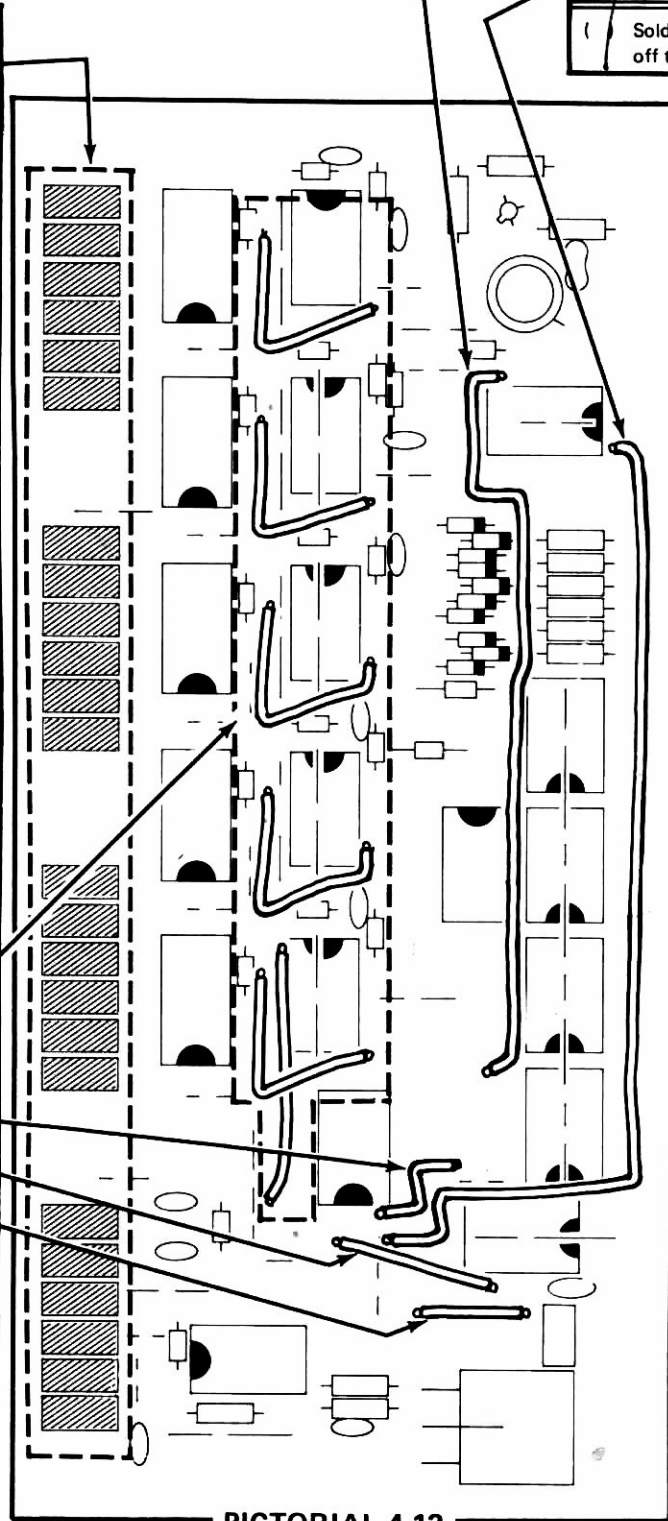

PICTORIAL 4-13

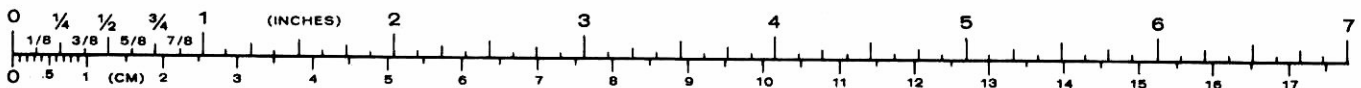

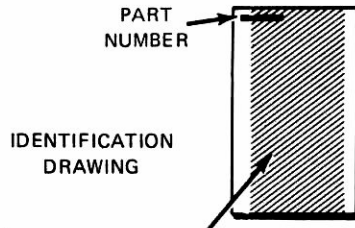

The steps performed in this Pictorial are in this area of the circuit board.

**KEEP YOUR
SOLDERING
IRON TIP
CLEAN**

START

In the following steps, you will install IC's. Be careful to match the pin 1 end of each IC to the half-moon mark on the circuit board. (See Detail 4-7A on Page 63.)

NOTE: Before you install an IC, first be sure the pins are straight. Then lay it down on one of its rows of pins, as shown below at A, and roll it over until the pins are at right angles or are bent in slightly as shown at B. Repeat this process for the other row of pins.

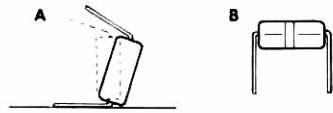

Before applying downward pressure to an IC, make sure each IC pin is centered in its proper socket aperture. Handle IC's with care as their pins are very easily bent.

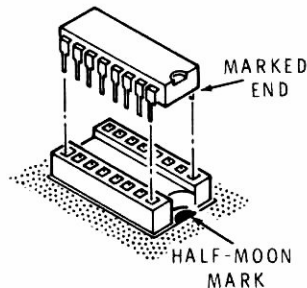

() IC103, IC105, IC107, IC109, IC111: Five SN7475N (#443-13) integrated circuits.

() IC112: SN7400N (#443-1) integrated circuit.

CONTINUE

() IC101: SN74H103DU (#443-70) integrated circuit.

() IC102, IC104, IC106, IC108, IC110: Five 74196 (#443-628) integrated circuits.

() IC117: SN7473N (#443-5) integrated circuit.

() IC113, IC114, IC115, IC116: SN7490N (#443-7) integrated circuits.

() IC118: SN7473N (#443-5) integrated circuit.

() IC119: SN7420N (#443-2) integrated circuit.

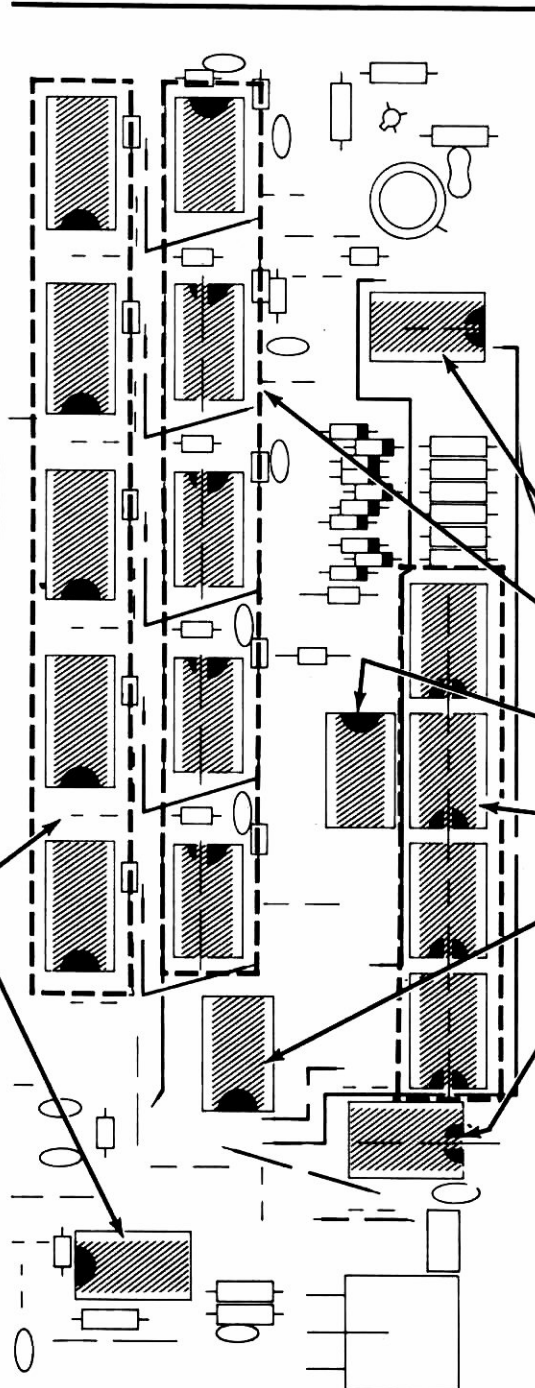

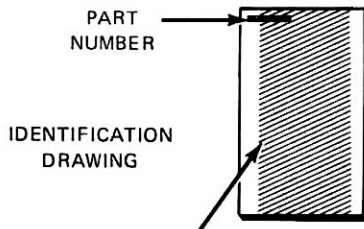

The steps performed in this Pictorial are in this area of the circuit board.

START →

NOTE: When you install disc capacitors, do not push the insulated portion of the leads into the circuit board holes. This could make it difficult to solder the leads to the foil.

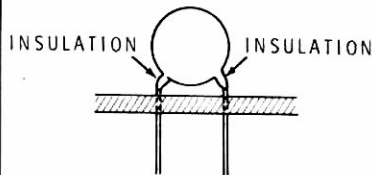

Install six .1 μ F disc capacitors at:

- () C101.
- () C106.
- () C107.
- () C108.
- () C109.
- () C111.

() C113: 5 pF disc.

() C112: .005 μ F disc.

Install three .1 μ F disc capacitors at:

- () C105.
- () C104.
- () C103.

() Solder all leads to the foil and cut off the excess lead lengths.

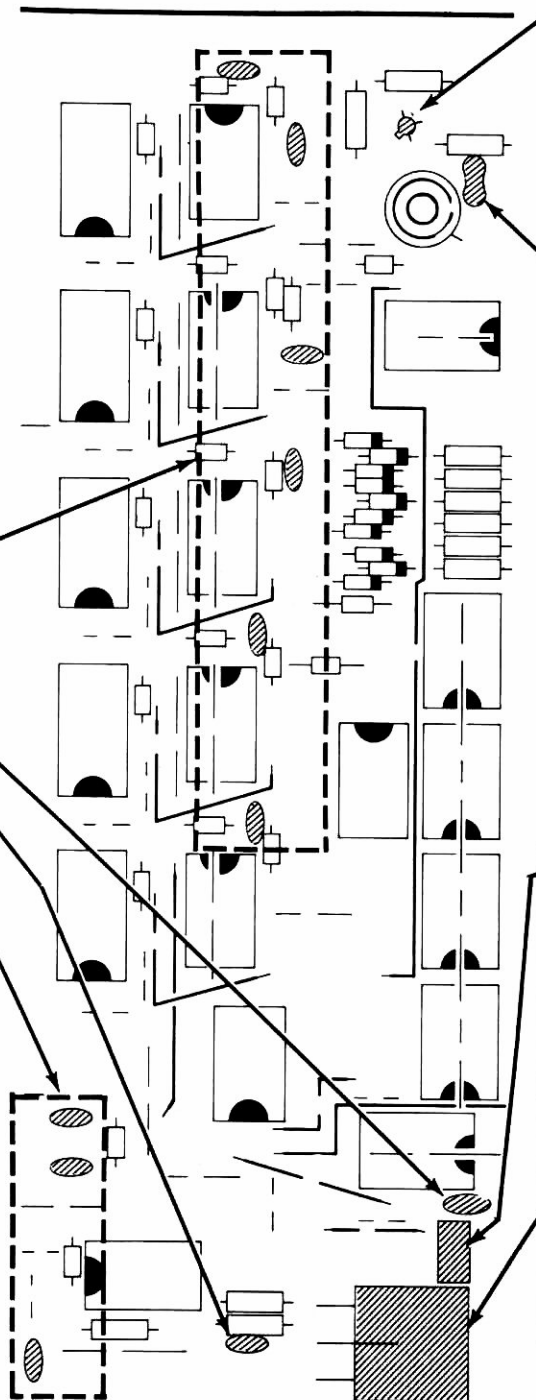

CONTINUE ▾

() Q101: 2N2369 transistor (#417-154). Align the tab on the transistor body with tab outline on the circuit board and insert the leads into the holes. Solder each lead to the foil and cut off the excess lead lengths.

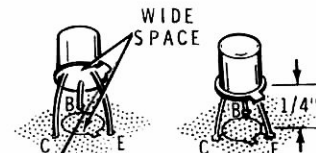

() C102: 36 pF mica. Insert the lead nearest J101 through the end hole of the center tab of J101. Solder the lead to the foil and to the tab.

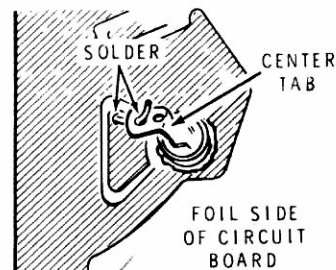

() C114: 2-8 pF trimmer capacitor. Solder the lugs to the foil.



() Y101: Crystal (#404-424) as shown. Solder the leads to the foil and cut off the excess lead lengths. Be sure the case of the crystal does not touch the trimmer capacitor you installed in the preceding step.

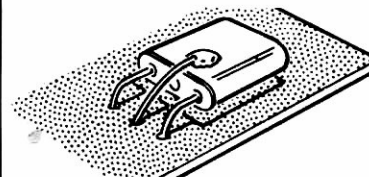

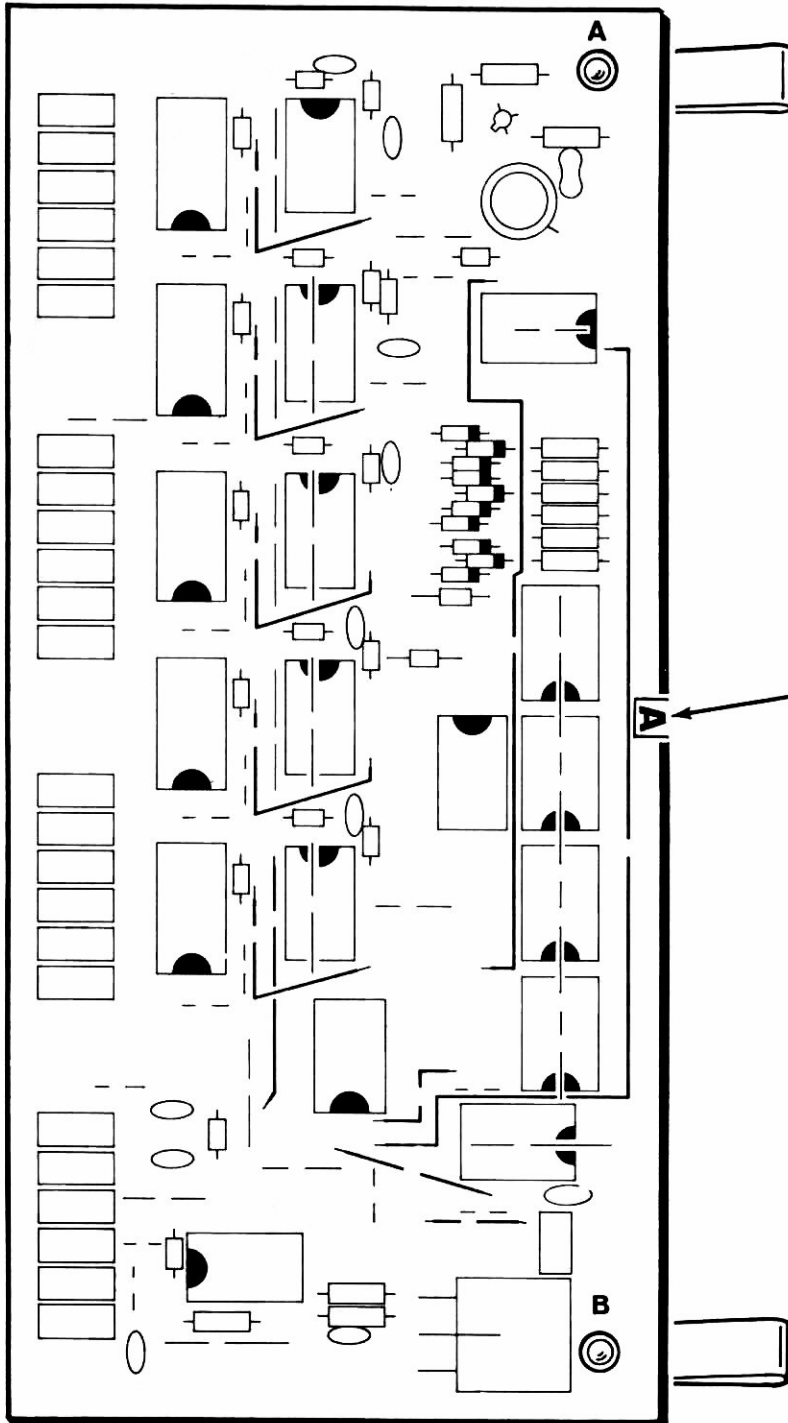

START ▾

- () Mount board pullers on the foil side of the circuit board at holes A and B. Position the female part in the circuit board hole. Then push the male part through the female part to the top of the board.

BOARD PULLER

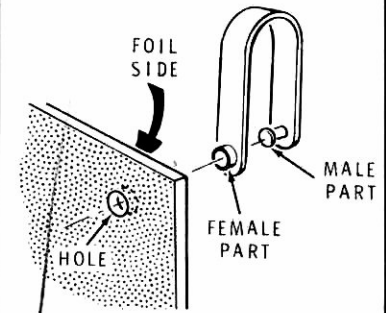

- () Cut out a letter "A" from the terminal identification label sheet.

- () Carefully remove the protective backing from the letter A and press this letter on the circuit board as shown.

CIRCUIT BOARD CHECKOUT

Carefully inspect the circuit board for the following conditions.

- () Unsoldered connections.
- () "Cold" solder connections.
- () Solder bridges between foils.
- () Protruding leads. No lead should be longer than 1/8".
- () Transistors for the proper type and installation.
- () Integrated circuits for the proper type and installation.
- () Diodes for the correct position of the banded end.
- () Lay the circuit board aside. It will be used later.

FINISH

PICTORIAL 4-16

VFO FILTER AND DRIVER CIRCUIT BOARDS

PARTS LIST

Remove the parts from Pack #5 and check each part against the following list. Make a check (✓) in the space provided as you identify each part. Any part that is packed in an individual envelope with the part number on it should be placed back in the envelope after you identify it until it is called for in a step. Do not throw away any packing materials until all parts are accounted for.

QTY.	DESCRIPTION	HEATH No.	CIRCUIT Component No.
------	-------------	--------------	--------------------------

RESISTORS

1/2-Watt

()	1	56 Ω (green-blue-black)	6-560	R901
()	2	100 Ω (brown-black-brown)	6-101	R1253, R1254
()	1	150 Ω (brown-green-brown)	6-151	R907
()	2	3900 Ω (orange-white-red)	6-392	R905, R906
()	2	22 kΩ (red-red-orange)	6-223	R1251, R1252

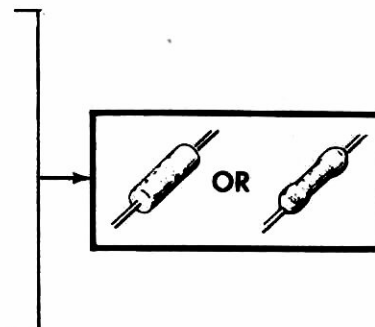

QTY.	DESCRIPTION	HEATH No.	CIRCUIT Component No.
Other Resistors			
()	1 470 Ω, 1-watt, 10% (yellow-violet-brown-silver)	1-1-1	R904
()	1 .51 ^{green} 33 Ω ^{Brown} , 2-watt (orange-silver-gold)	3-2-2	R902
()	1 220 Ω, 2-watt, 10% (red-red-brown-silver)	1-13-2	R903
()	1 175 Ω, 5-watt	3-16-5	R903

CAPACITORS

Disc			
()	1	200 pF	21-21 C1251
()	1	470 pF	21-56 C901
()	1	820 pF	21-150 C903
()	1	.001 μF	21-140 C909
()	10	.01 μF	21-176 C904, C907, C911, C912, C913, C914, C915, C916, C1252, C1255

Other Capacitors

()	1	230 pF mica	20-111 C902
()	2	1000 pF mica	20-172 C1253, C1254
()	1	10 μF electrolytic	25-54 C908
()	1	250 μF electrolytic	25-262 C905
()	1	.1 μF Mylar	27-47 C906

DIODES-TRANSISTORS

()	2	1N191 diode (brown-white-brown)	56-26 D905, D906
()	2	DRS-110 silicon diode	57-64 D903, D904
()	2	1N4002 ^{IN-2071} (silicon diode)	57-65 D901, D902
()	2	CD-3342 or PT6619 transistor*	417-830 Q901, Q902
()	1	2N5770 transistor	417-293 Q1251

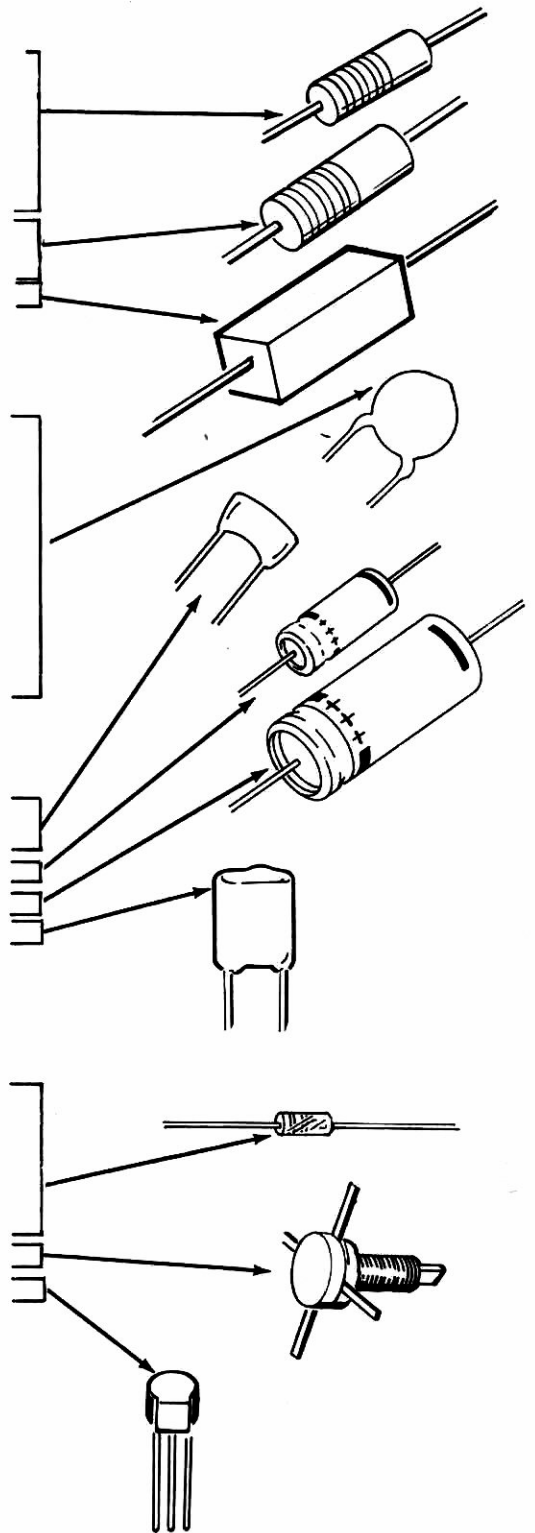

*If ordering transistors, don't forget to order thermal compound, #352-31.

QTY.	DESCRIPTION	HEATH No.	CIRCUIT Component No.
INDUCTORS			
() 2	14.5 μ H coil	40-1052	L901, L902
() 2	1.31 μ H coil	40-1869	L1251, L1253
() 1	2.3 μ H coil	40-1872	L1252
() 1	2.2 μ H choke	45-73	RFC901
() 2	350 μ H choke	45-82	RFC902, RFC903

HARDWARE

() 3	6-32 x 1/2" screw	250-162
() 3	#6 lockwasher	254-1
() 3	1/8" spacer	255-1
() 3	15/32" tapped spacer	255-23
() 2	8-32 nut	252-4

MISCELLANEOUS

() 6	Circuit board connector	432-124
() 2	Phono socket	434-186
() 1	Heat sink	215-80
() 1	Thermal compound*	352-31
() 2	O ring	253-115

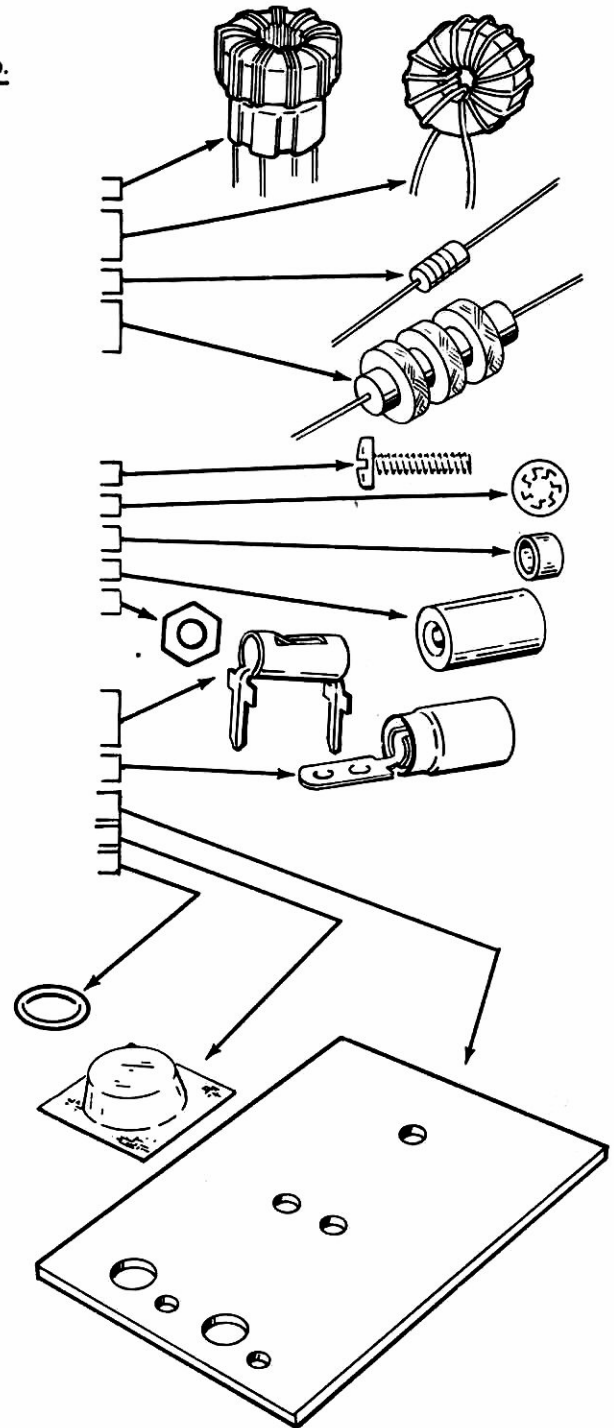

PARTS FROM PACK #10

() 1	Driver circuit board	85-1421-5
() 1	VFO filter circuit board	85-1930-1

To order a replacement part, always include the PART NUMBER. Use the Parts Order Form furnished with this kit. If one is not available, see "Replacement Parts" inside the rear cover of this Manual. Your Warranty is located inside the front cover. For pricing information, refer to the separate "Heath Parts Price List."

* Dow Corning thermal heat sink compound contains Zinc Oxides, SiO₂, and slight traces of CO₂.

STEP-BY-STEP ASSEMBLY

VFO FILTER CIRCUIT BOARD

CUT THE CABLE ACCORDING TO THE DIMENSIONS BELOW. PREPARE EACH END AS SHOWN.

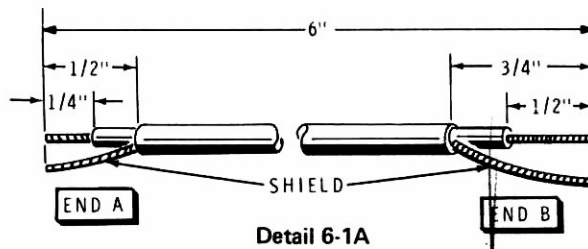

START

Position the VFO/filter circuit board (#85-1930-1) as shown and complete the following steps.

NOTE: To prepare a length of wire, cut it to the indicated length and remove 1/4" of insulation from each end.

() Prepare a 1-3/4" gray wire. Then insert one end of this wire in hole D and solder the wire to the foil. The free end of this wire will be connected later.

() L1253: Toroid coil (#40-1869).



() C1254: 1000 pF mica.

() L1252: Toroid coil (#40-1872).

() C1253: 1000 pF mica.

() L1251: Toroid coil (#40-1869).

() R1254: 100 Ω (brown-black-brown).

() R1252: 22 kΩ (red-red-orange).

() C1251: 200 pF disc.

() Solder the leads to the foil and cut off the excess lead lengths.

CONTINUE

() C1255: .01 μF disc.

() Prepare a 1-3/4" red wire. Then insert one end of this wire in hole C and solder the wire to the foil. The free end of this wire will be connected later.

() R1253: 100 Ω (brown-black-brown).

() C1252: .01 μF disc.

() R1251: 22 kΩ (red-red-orange).

Solder the leads to the foil and cut off the excess lead lengths.

() Q1251: 2N5770 transistor (#417-293). First line up the flat on the transistor with the outline of the flat on the circuit board. Then insert the transistor leads into their corresponding holes indicated by E, B, and C. Solder the leads to the foil and cut off the excess lead lengths.

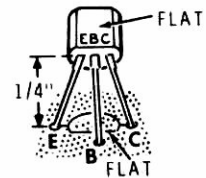

() Refer to Detail 6-1A and prepare a 6" length of shielded cable. NOTE: DO NOT use RG-58A/U.

() At end A of the cable, connect the center conductor to A (S-1) and the shield to B (S-1). End B will be connected later.

() Squeeze a little of the cement (saved from the VFO steps) into the centers of the three toroid coils to affix them to the circuit board.

() Lay the circuit board aside. It will be used later.

PICTORIAL 6-1

DRIVER CIRCUIT BOARD

START

Position the driver circuit board as shown. Then proceed with the following steps.

NOTE: The circuit board will be mounted close to a metal plate. To avoid short circuits, use a minimum amount of solder that will still produce good solder connections. Then cut the excess lead lengths as short as possible.

(✓) R907: 150 Ω (brown-green-brown).

(✓) R905: 3900 Ω (orange-white-red).

(✓) R906: 3900 Ω (orange-white-red).

(✓) R901: 56 Ω (green-blue-black).

(✓) REC901: 2.2 μH choke (#45-73).

(✓) Solder the leads to the foil and cut off the excess lead lengths.

Install circuit board connectors in the follow manner. Note that inside each connector the spring contact is depressed on one end. This depressed end of the connector should face away from the edge of the circuit board. Insert the mounting tabs through the circuit board until the ridges of the connector are firmly against the circuit board. Look at the row of connectors to make sure the depressed end of the contact of each connector is toward the center of the circuit board. Solder the tabs to the foil.

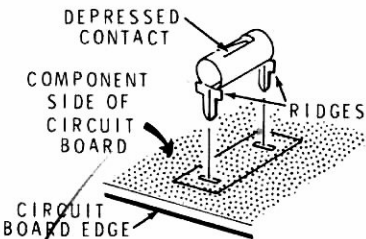

(✓) Six circuit board connectors.

PART NUMBER

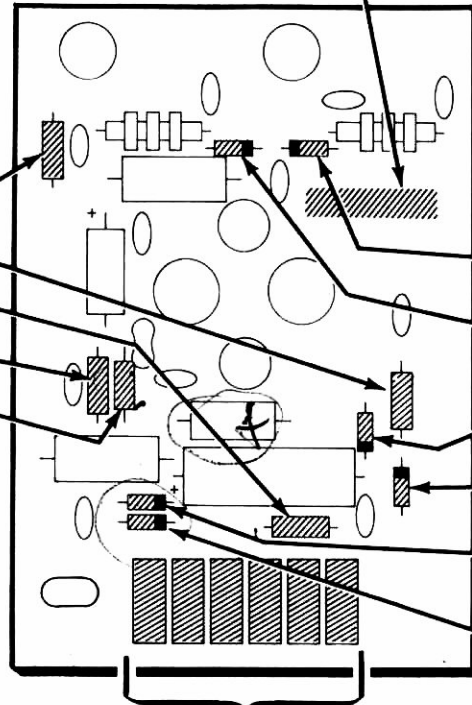

CONTINUE

NOTE: When you install a diode, always match the banded end of the diode with the band mark on the circuit board.

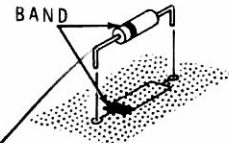

(✓) D903: CRS-110 silicon diode (#57-64). Do not confuse this diode with the #57-65 diode.

(✓) D904: CRS-110 silicon diode (#57-64).

(✓) D906: 1N191 diode (brown-white-brown) (#56-26).

(✓) D905: 1N191 diode (brown-white-brown) (#56-26).

(✓) D901: 1N207 silicon diode (#57-85).

(✓) D902: 1N4002 silicon diode (#57-65).

FOR GOOD SOLDER CONNECTIONS, YOU MUST KEEP THE SOLDERING IRON TIP CLEAN. WIPE IT OFTEN WITH A DAMP SPONGE OR CLOTH.



(✓) Solder the leads to the foil and cut off the excess lead lengths.

PICTORIAL 6-2

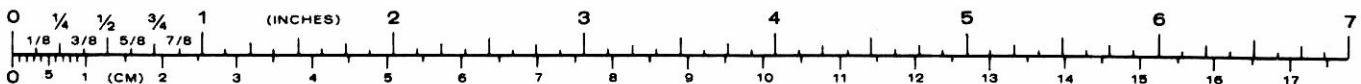

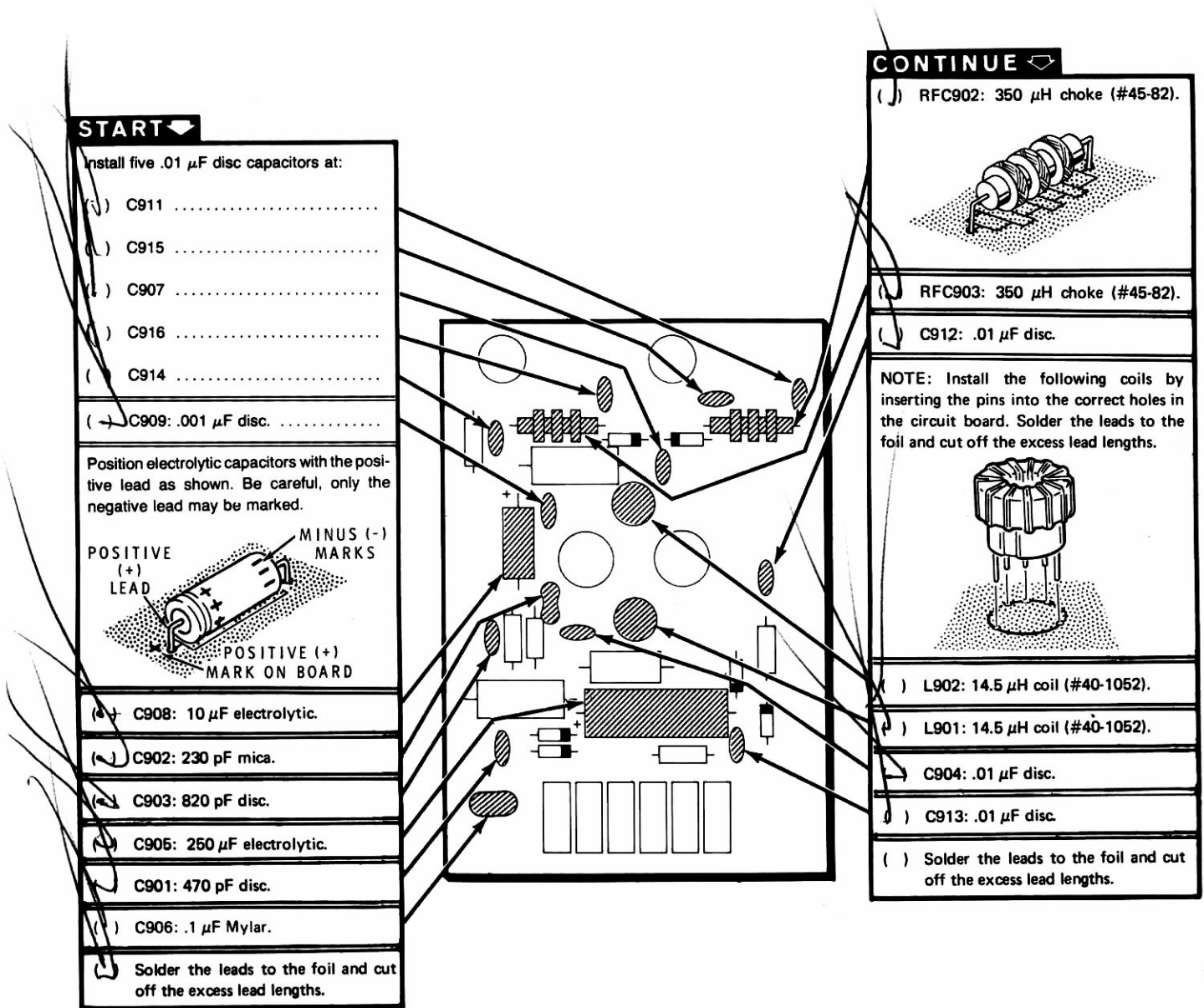

START →

- Install five .01 μ F disc capacitors at:
- () C911
 - () C915
 - () C907
 - () C916
 - () C914
 - (→) C909: .001 μ F disc.

Position electrolytic capacitors with the positive lead as shown. Be careful, only the negative lead may be marked.

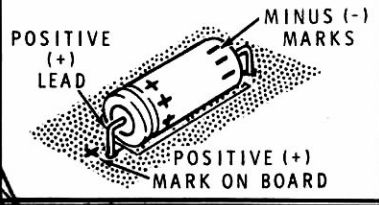

- (+) C908: 10 μ F electrolytic.
- () C902: 230 pF mica.
- () C903: 820 pF disc.
- () C905: 250 μ F electrolytic.
- () C901: 470 pF disc.
- () C906: .1 μ F Mylar.

Solder the leads to the foil and cut off the excess lead lengths.

CONTINUE →

- () RFC902: 350 μ H choke (#45-82).
- () RFC903: 350 μ H choke (#45-82).
- () C912: .01 μ F disc.

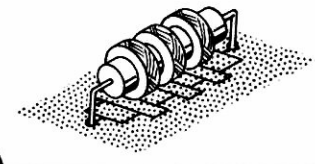

NOTE: Install the following coils by inserting the pins into the correct holes in the circuit board. Solder the leads to the foil and cut off the excess lead lengths.



- () L902: 14.5 μ H coil (#40-1052).
 - () L901: 14.5 μ H coil (#40-1052).
 - () C904: .01 μ F disc.
 - () C913: .01 μ F disc.
- () Solder the leads to the foil and cut off the excess lead lengths.

PICTORIAL 6-3

START →

IMPORTANT: If the two power transistors furnished (part #417-830) are type CD-3342, install them as shown in this Pictorial. If the transistors furnished are type PT6619, follow the steps on Page 1-80 and disregard this page.

NOTE: When you mount a phono socket, position each socket so its lug can be bent over to touch the appropriate foil shown by arrows A or B.

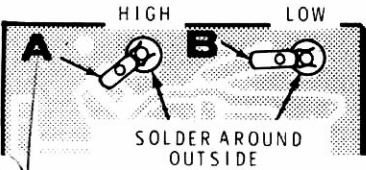

() Phono socket at LOW.

() Phono socket at HIGH.

() Bend each phono socket lug over so its end touches foil A or B. Be sure no part of this lug touches the socket body. However, the clearance between this lug and the socket body must be as small as possible. Solder each lug to the foil.



() Use an ohmmeter to make sure there is an open circuit between each phono socket center conductor and the ground foil.

Turn the circuit board foil-side-down to perform the next three steps.

() R904: 470 Ω, 1-watt (yellow-violet-brown).

() R903: 175 Ω, 5-watt
2200 2-watt

() R902: *33 2-watt* .33 Ω, 2-watt (orange-orange-silver-gold).
green brown silver gold

() Solder the leads to the foil and cut off the excess lead lengths.

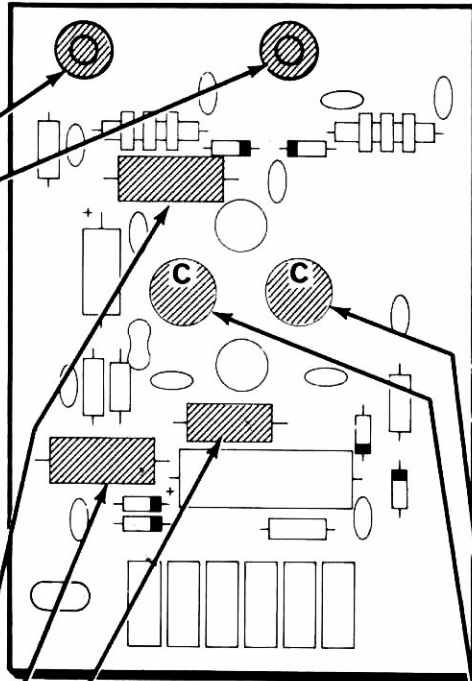

CONTINUE →

CAUTION: Handle power transistors, particularly the studs, with care.

() Stretch the two "O" rings by rolling them onto a round object such as a pencil. Repeat this action two or three times to stretch each "O" ring the maximum amount. Then remove the rings.



() Carefully stretch an "O" ring onto the round, white top of each transistor.

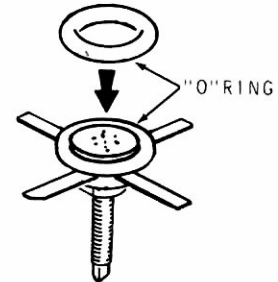

Cut the four leads of each of the CD-3342 transistors (#417-830) to 3/16". Mount the transistor with its threaded stud and its leads on the foil side of the circuit board. The collector lead is identified by letters "CTC" on the top of the transistor.

1. Be SURE the letters CTC match the letter C on the circuit board.
2. Be SURE the transistor studs are perpendicular to the circuit board before you solder.
3. Check a second time that the letters CTC and C match each other.

COLLECTOR LEADS

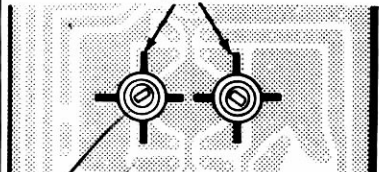

() Q902: CD-3342 transistor.

() Q901: CD-3342 transistor.

() Solder the four leads of each transistor to the foil.

NOTE: If you performed the steps in this Pictorial, you will have a 220 Ω, 2-watt resistor (red-red-brown) left over which will not be used.

Proceed to "Circuit Board Checkout" on Page 1-81.

PICTORIAL 6-4

START ▾

IMPORTANT: Follow this Pictorial **ONLY** if you were furnished two type PT6619 transistors (part #417-830).

NOTE: When you mount a phono socket, position each socket so its lug can be bent over to touch the appropriate foil shown by arrows A or B.

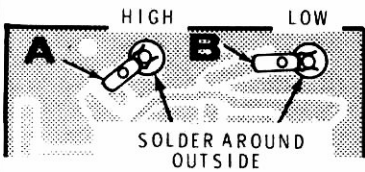

() Phono socket at LOW.

() Phono socket at HIGH.

() Bend each phono socket lug over so its end touches foil A or B. Be sure no part of this lug touches the socket body. However, the clearance between this lug and the socket body must be as small as possible. Solder each lug to the foil.



() Use an ohmmeter to make sure there is an open circuit between each phone socket center conductor and the ground foil.

Turn the circuit board foil-side-down to perform the next three steps.

() R904: 470 Ω , 1-watt (yellow-violet-brown).

() R903: 220 Ω , 2-watt (red-red-brown).

() R902: .33 Ω , 2-watt (orange-orange-silver-gold).

() Solder the leads to the foil and cut off the excess lead lengths.

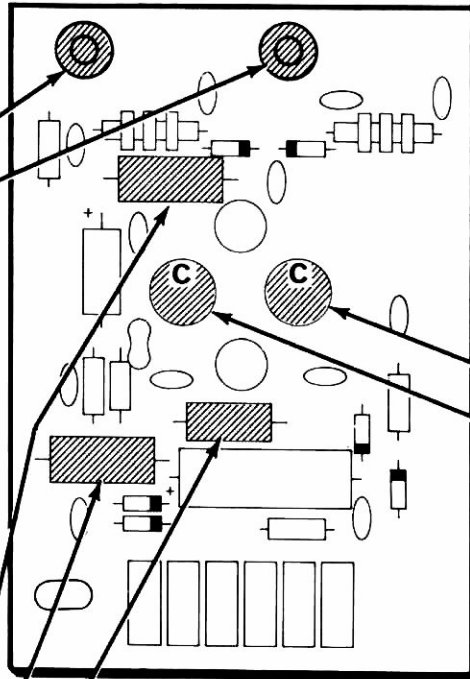

PICTORIAL 6-5

CONTINUE ▾

Cut the four leads of each of the PT6619 transistors (#417-830) to 3/16". Mount the transistor with its threaded stud and its leads on the foil side of the circuit board. The collector lead is identified by letter "C" on the top of the transistor.

1. Be SURE the letter C matches the letter C on the circuit board.
2. Be SURE the transistor studs are perpendicular to the circuit board before you solder.
3. Check a second time that the letters C match each other.



() Q902: PT6619 transistor.

() Q901: PT6619 transistor.

() Solder the four leads of each transistor to the foil.

NOTE: If you performed the steps in this Pictorial, you will have a 140 Ω , 5-watt resistor and two O rings left over which will not be used.

Proceed to "Circuit Board Checkout" on Page 1-81.

CIRCUIT BOARD CHECKOUT

Carefully inspect the circuit boards for the following conditions. () Transistors for the proper type and installation.

() Unsoldered connections.

() Electrolytic capacitors for the correct position of the positive (+) end.

() "Cold" solder connections.

() Diodes for the correct position of the banded end.

() Solder bridges between foil patterns.

() Protruding leads. No lead should be longer than 1/8".

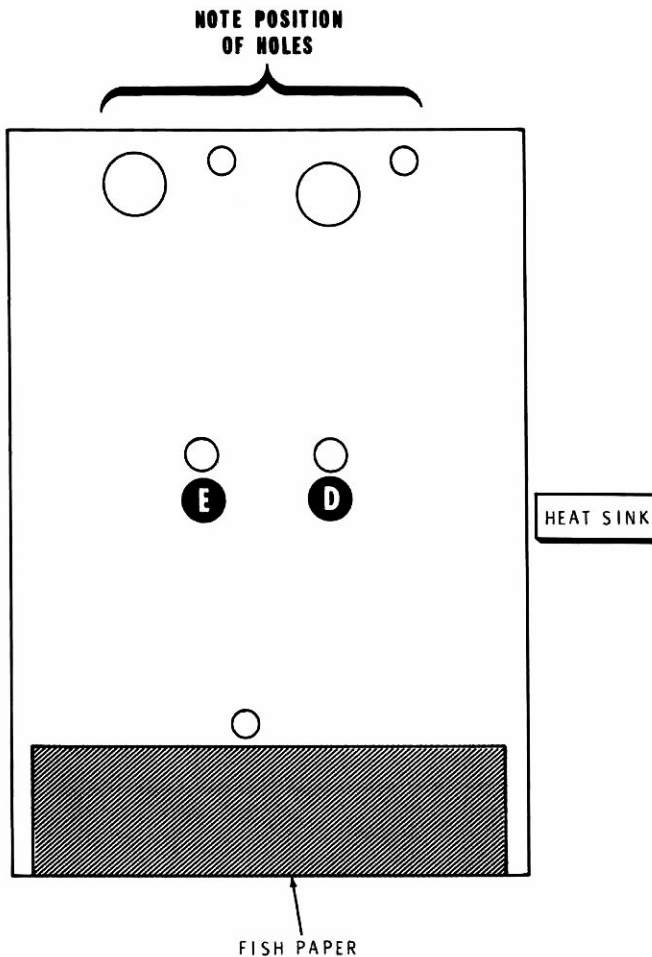

Heat Sink Assembly

Refer to Pictorial 6-6 (Illustration Booklet, Page 2) for the following steps.

- () Refer to Detail 6-6A, remove the paper backing from a 2-3/4" x 3/4" piece of fish paper (left over from previous steps), and mount the paper in the position shown.
- () If the nuts supplied with the transistors are threaded on the transistor studs, remove them temporarily.

WARNING: You will be using Dow Corning 340 thermal heat sink compound in the next step and in several other steps in the Manual. Although the compound is not caustic, it may cause temporary discomfort if it gets into your eyes. Should this happen, rinse your eyes with warm water. If the compound gets into your clothing, the clothing may require professional cleaning. The compound contains Zinc Oxides, SiO₂, and slight traces of CO₂.

- () Refer to inset drawing #1 on the Pictorial. Cut open the thermal compound and squeeze out a small amount of it. Use an applicator to liberally coat an area about 1/4" around holes D and E on the fish paper side of the heat sink.

- () Wash the thermal compound from your hands.

NOTE: Save the remaining compound for use later.

- () Place a 6-32 x 1/2" screw through hole A from the top of the circuit board. Hold the screw in place with your finger and turn the circuit board foil-side-up. Place a 1/8" spacer over the end of the screw. Then lower the heat sink onto the screw so the transistor studs fit through holes D and E in the heat sink. Place a #6 lockwasher onto the 1/2" screw; then turn a 15/32" tapped spacer onto the screw (only finger tight).
- () In the same manner, secure the circuit board to the heat sink at B and C. Use a 6-32 x 1/2" screw, a 1/8" spacer, a #6 lockwasher, and a 15/32" tapped spacer at each location.
- () Tighten the three screws and spacers at A, B, and C.

NOTE: To avoid damage to the power transistors, it is important that you follow exactly the instructions for tightening the nuts in the following steps.

- () Start a transistor nut onto each transistor stud at D and E. Use the nuts supplied with the transistors, if any. If none are furnished, use those in the parts pack.
- () Use your fingers **ONLY** and tighten the two nuts as much as possible.
- () Hold the wrench flats on the end of the transistor stud with pliers to keep the transistor stud from turning as shown in inset #2 of the Pictorial. Then tighten each transistor mounting nut 1/8 turn more.
- () Carefully check the space between the underside of the circuit board and the heat sink to be sure none of the component leads or solder connections touch the heat sink. Be sure to carefully check the center conductors of the phono sockets.

This completes the assembly of your driver circuit board. Set it aside temporarily and proceed to "ALC/Output Filter Circuit Board."

ALC/OUTPUT FILTER CIRCUIT BOARD

PARTS LIST

Remove the parts from Pack #6 and check each part against the following list. Make a check (✓) in the space provided as you identify each part. Any part that is packed in an individual envelope with the part number on it should be placed back in the envelope after you identify it until it is called for in a step. Do not throw away any packing materials until all parts are accounted for.

QTY.	DESCRIPTION	HEATH No.	CIRCUIT Component No.
RESISTORS			
() 1	220 Ω (red-red-brown)	6-221	R804
() 1	1000 Ω (brown-black-red)	6-102	R808
() 3	3300 Ω (orange-orange-red)	6-332	R801, R805, R806
() 1	4700 Ω (yellow-violet-red)	6-472	R809
() 1	6200 Ω (blue-red-red)	6-622	R803
() 1	10 kΩ (brown-black-orange)	6-103	R807
Other Resistors			
() 1	150 Ω, 1-watt (brown-green-brown)	1-18-1	R802

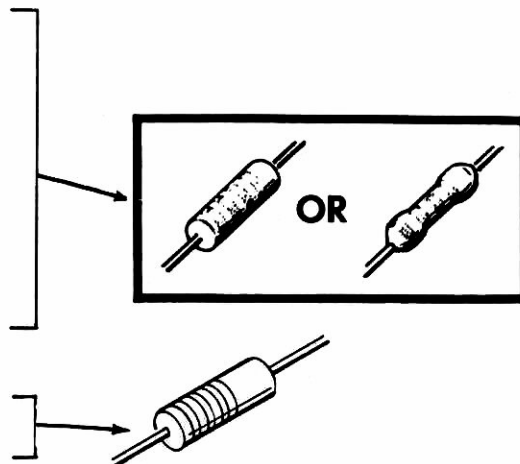

QTY.	DESCRIPTION	HEATH No.	CIRCUIT Component No.	
()	1	12 pF	20-130	C806
()	1	30 pF	20-100	C812
()	1	62 pF	20-109	C809
()	1	82 pF	20-141	C805
()	2	90 pF	20-119	C815, C831
()	2	105 pF	20-162	C802, C804
()	1	130 pF	20-104	C801
()	1	150 pF	20-103	C803
()	1	270 pF	20-114	C808
()	1	290 pF	20-121	C807
()	1	300 pF	20-115	C824
()	2	470 pF	20-113	C811, C814
()	2	620 pF	20-167	C817, C819
()	1	680 pF	20-107	C816
()	1	820 pF	20-171	C813
()	1	1000 pF	20-122	C822
()	2	1800 pF	20-137	C818, C821

Other Capacitors

()	1	10 pF disc	21-3	C823
()	4	.001 μ F disc	21-140	C825, C826, C828, C829
()	1	.68 μ F electrolytic	25-922	C827

INDUCTORS

NOTE: The following inductors are toroid type coils unless otherwise noted. Leave these inductors in their envelopes until they are called for in a step.

()	1	.13 μ H (white and red dots)	40-1861	L801
()	1	.59 μ H	40-1966	L805
()	1	.66 μ H	40-1967	L804
()	2	.44 μ H (white and green dots)	40-1865	L802, L803
()	1	.825 μ H (white and yellow dots)	40-1867	L810
()	1	1.1 μ H	40-1968	L808
()	1	1.28 μ H	40-1969	L807
()	1	1.31 μ H (green dot)	40-1869	L811
()	1	1.59 μ H (red dot)	40-1870	L812
()	1	30 μ H	40-1011	L813
()	2	.82 μ H peaking coil	40-1713	L814, L815

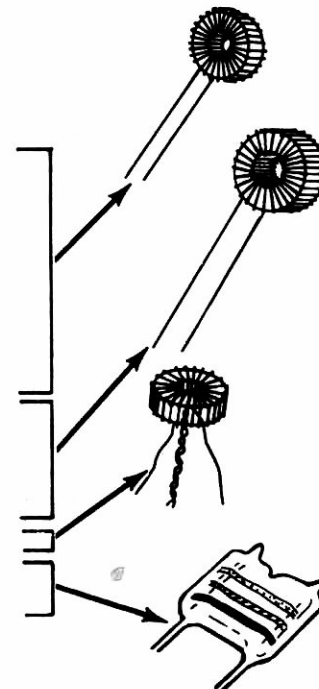
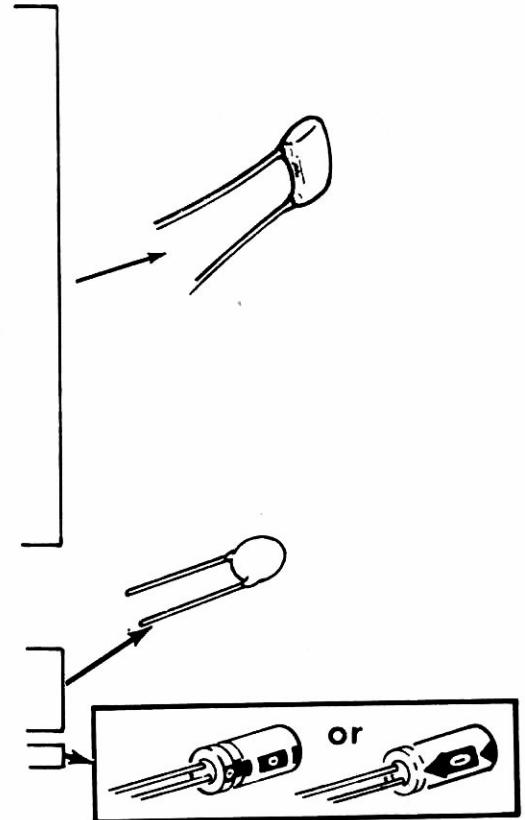

<u>QTY.</u>	<u>DESCRIPTION</u>	<u>HEATH No.</u>	<u>CIRCUIT Component No.</u>
MISCELLANEOUS			
() 3	1N295 diode (red-white-green)	56-20	D801, D802, D803
() 1	Rotary switch	63-723	SW1C, SW1D
() 1	#6 flat fiber washer	253-1	
() 1	Eyelet	257-12	
() 6	Circuit board connector	432-124	
() 2	MPSA20 transistor	417-801	Q801, Q802
() 2	Phono socket	434-186	
PART FROM PACK #10			
() 1	ALC/output filter circuit board	85-2187-1	

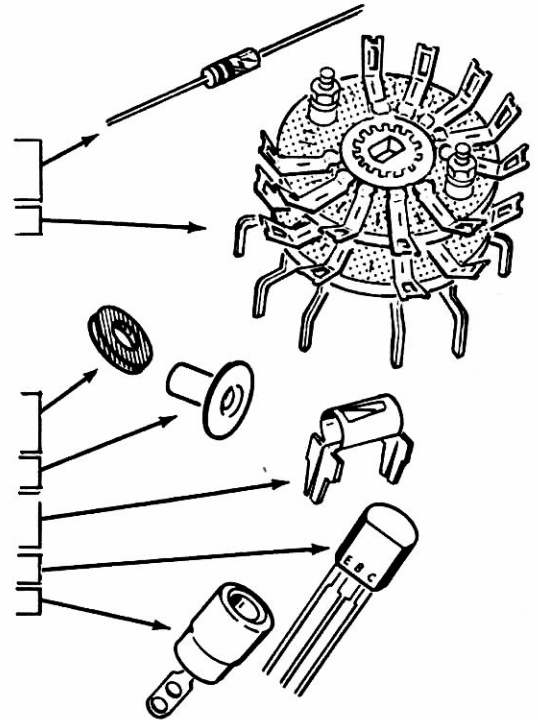

To order a replacement part, always include the PART NUMBER. Use the Parts Order Form furnished with this kit. If one is not available, see "Replacement Parts" inside the rear cover of this Manual. Your Warranty is located inside the front cover. For pricing information, refer to the separate "Heath Parts Price List."

STEP-BY-STEP ASSEMBLY

The steps performed in this Pictorial are in this area of the circuit board.

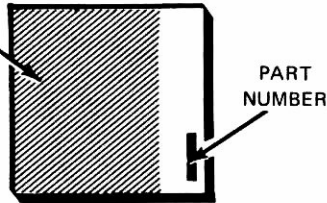

IDENTIFICATION DRAWING

START

Position the ALC/output filter circuit board (#85-2187) as shown on the identification drawing. Then proceed with the following steps.

() Install six circuit board connectors in the following manner. Note that inside each connector the spring contact is depressed on one end. This depressed end of the connector should face away from the edge of the circuit board. Insert the mounting tabs through the circuit board until the ridges of the connector are firmly against the circuit board. Look at the row of connectors to make sure the depressed end of the contact of each connector is toward the center of the circuit board. Solder the tabs to the foil.

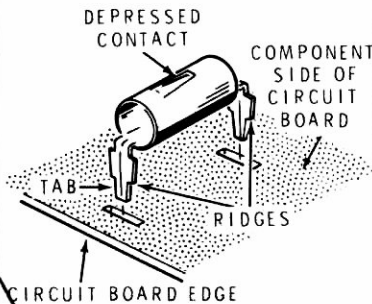

- () R806: 3300 Ω (orange-orange-red).
- () R805: 3300 Ω (orange-orange-red).
- () R804: 220 Ω (red-red-brown).
- () R809: 4700 Ω (yellow-violet-red).
- () R801: 3300 Ω (orange-orange-red).
- () R803: 6200 Ω (blue-red-red).
- () R802: 150 Ω , 1-watt (brown-green-brown).
- () R808: 1000 Ω (brown-black-red).
- () R807: 10 k Ω (brown-black-orange).
- () Solder the leads to the foil and cut off the excess lead lengths.

CONTINUE

- () C802: 105 pF mica.
- () C801: 130 pF mica.
- () C831: 90 pF mica.
- () C803: 150 pF mica.
- () C804: 105 pF mica.
- () C823: 10 pF disc.
- () C811: 470 pF mica.
- () Solder the leads to the foil and cut off the excess lead lengths.

NOTE: When you install a diode, always match the banded end of the diode with the band mark on the circuit board. See Detail 7-1A.

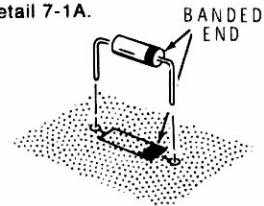

Install three IN295 diodes (#56-20) at:

- () D802.
- () D801.
- () D803.

FOR GOOD SOLDER CONNECTIONS, YOU MUST KEEP THE SOLDERING IRON TIP CLEAN.
WIPE IT OFTEN WITH A DAMP SPONGE OR CLOTH.



- () Solder the leads to the foil and cut off the excess lead lengths.

PICTORIAL 7-1

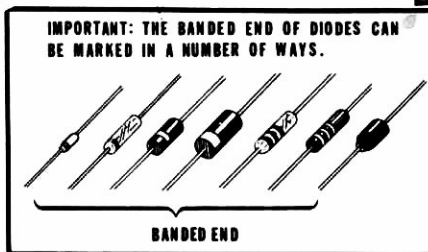

The steps performed in this Pictorial are in this area of the circuit board.

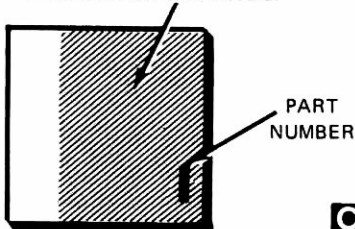

IDENTIFICATION DRAWING

START

NOTE: When you install toroid coils in the following steps, do not remove a coil from its envelope until you are ready to mount it. Then start the leads through their holes in the top of the board. Grasp the lead ends of the foil side of the board and pull the coil down onto the board. Solder the leads as you install each coil. Then cut off the excess lead lengths.

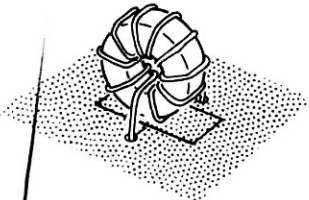

- () L804: .66 μ H coil (#40-1967).
- () L805: .59 μ H coil (#40-1966).
- () L807: 1.28 μ H coil (#40-1969).
- () L808: 1.1 μ H coil (#40-1968).
- () L812: 1.59 μ H coil (#40-1870, red dot).
- () L870: .825 μ H coil (#40-1867, white and yellow dots).
- () L811: 1.31 μ H coil (#40-1869, green dot).

NOTE: To mount a circuit board socket, seat the socket in its hole on the top of the circuit board. Turn the circuit board over and support the socket with the corner of a book to hold the socket up against the board. Position the lug over the foil pad as shown. Then solder the socket to the foil by moving a soldering iron around the socket and foil while you apply solder. The lug will be soldered later.

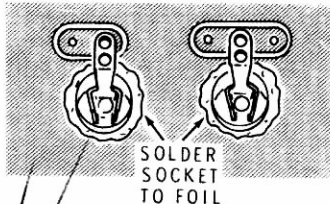

- () Phono socket at IN.
- () Phono socket at OUT.

CONTINUE

- () C805: 82 pF mica.
- () C807: 290 pF mica.
- () C806: 12 pF mica.
- () C809: 62 pF mica.
- () C808: 270 pF mica.
- () Solder the leads to the foil and cut off the excess lead lengths.
- () C813: 820 pF mica.
- () C815: 90 pF mica.
- () C814: 470 pF mica.
- () C816: 880 pF mica.
- () C818: 1800 pF mica.
- () Solder the leads to the foil and cut off the excess lead lengths.

NOTE: In each of the next two steps, bend the inner lug of the phono socket as shown. Then push a small bare wire through the lug and into the circuit board hole. Solder the wire to both the lug and the foil and cut off the excess wire lengths. Be careful not to short the lug to the phono socket shell.

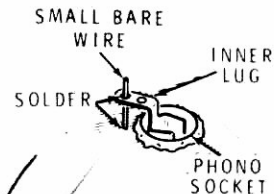

- () 3/4" wire at F.
- () 3/4" wire at G.

PICTORIAL 7-2

The steps performed in this Pictorial are in this area of the circuit board.

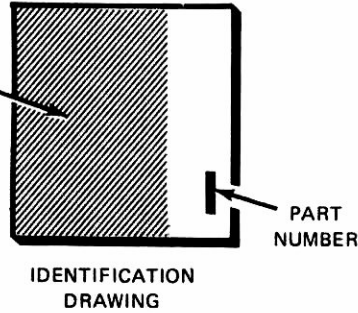

START ↓

- () L813: Install a 30 μ H coil (#40-1011) as follows:
1. Refer to the drawing below and push the #6 flat fiber washer onto the eyelet. (It is a tight fit.)
 2. Push the eyelet through the center of the coil as shown, either side up. Then push the eyelet through the circuit board. Position the leads as shown and solder the eyelet to the foil.
 3. Push the leads through the circuit board. **IMPORTANT:** Be sure the twisted pair of leads go into the center hole. The lead coming from the bottom of the coil must go to the hole nearest the 10 pF disc capacitor. The lead from the top must go to the hole nearest the 1000 pF mica capacitor.
 4. Solder the three leads to the foil and remove any excess lead lengths.

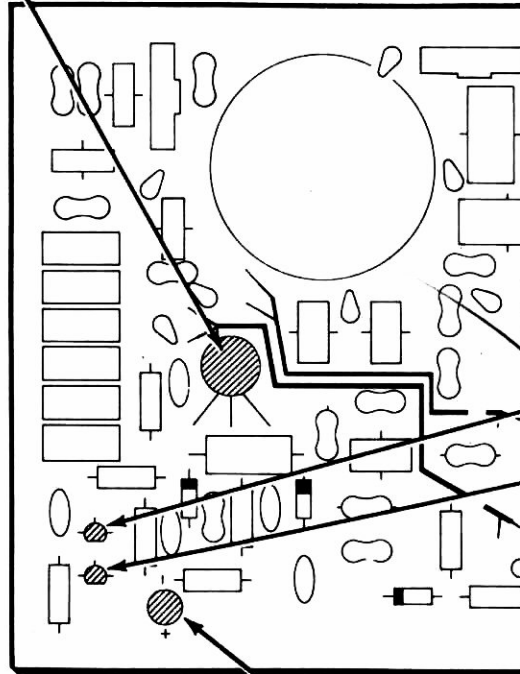
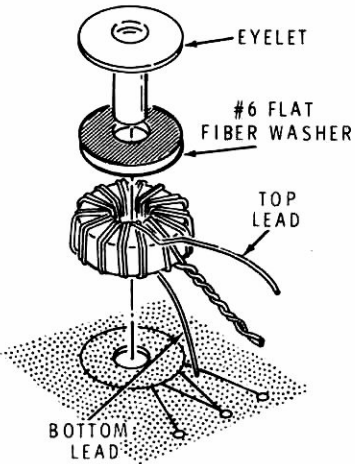

CONTINUE ↓

NOTE: In each of the following steps where a transistor is installed, line up the flat on the transistor with the flat on the circuit board. Then insert the transistor leads into the corresponding E, B, and C holes in the circuit board. Solder the leads to the foil and cut off the excess lead lengths.

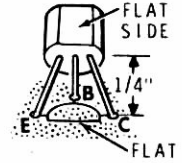

() Q801: MPSA20 transistor (#417-801).

() Q802: MPSA20 transistor (#417-801).

NOTE: Before you install an electrolytic capacitor, look at it and identify the leads. One lead will have a plus (+) mark or a minus (-) mark near it. **Be sure** to install the positive lead in the positive-marked hole. Be careful: only the negative lead may be marked.

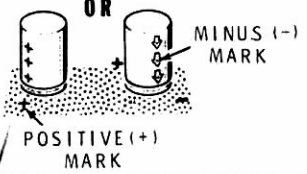

() C827: .68 μ F electrolytic. NOTE: Your circuit board may be screened 5.

PICTORIAL 7-3

The steps performed in this Pictorial are in this area of the circuit board.

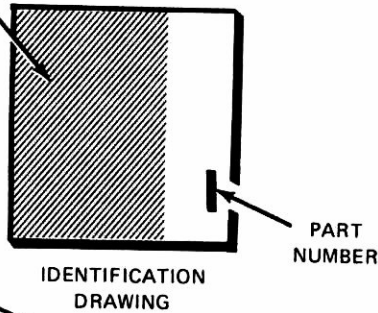

START ↓

() L815: .82 μ H peaking coil (#40-1713).

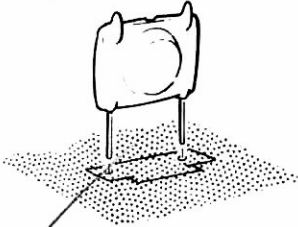

() L814: .82 μ H peaking coil (#40-1713).

() L807: .13 μ H coil (#40-1861, white and red dots).

() L802: .44 μ H coil (#40-1865, white and green dots).

() L803: .44 μ H coil (#40-1865, white and green dots).

() C825: .001 μ F disc.

() C824: 300 pF mica.

() C826: .001 μ F disc.

() C829: .001 μ F disc.

() Solder the leads to the foil and cut off the excess lead lengths.

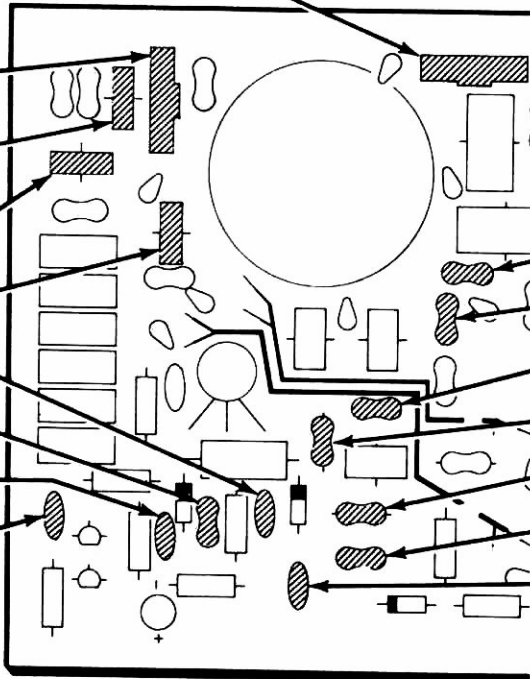

CONTINUE ↓

() C812: 30 pF mica.

() C811: 470 pF mica.

() C817: 620 pF mica.

() C822: 1000 pF mica.

() C821: 1800 pF mica.

() C819: 620 pF mica.

() C828: .001 μ F disc.

() Solder the leads to the foil and cut off the excess lead lengths.

PICTORIAL 7-4

The steps performed in this Pictorial are in this area of the circuit board.

START →

- (1) Orient the ten rotary switch lugs with the circuit board holes. Then carefully turn the rotors in both switch wafers so the index notches are in the position shown. You may want to use one of the switch shafts from Pack #11 to turn the rotors.
- (2) SW1C-SW1D: Rotary switch (#63-723). Push the Switch firmly down onto the circuit board. Then solder the ten lugs to the circuit board foil. In further steps, only the top wafer lugs will be connected.
- (3) Form a 2" length of small bare wire so it curves around, and touches, switch lugs 5 through 12. Then bend the ends of the wire so they enter switch lugs 5 and 12. Solder the wire to all the lugs except lug 12.
- (4) Prepare the following lengths of gray wire.
1-1/2" 1-1/4" 1-1/4" 1-1/2" 1-1/4"
- As you install the wires in the following steps, solder both ends of the wire and cut off any excess wire lengths.
- (5) 1-1/2" wire from A to switch lug 3.
- (6) 1-1/4" wire from X to switch lug 12 (also solder the bare wire.)
- (7) 1-1/4" wire from B to switch lug 16.
- (8) 1-1/2" wire from C to switch lug 18.
- (9) 1-1/4" wire from D to switch lug 20.
- (10) Prepare two lengths of shielded cable (one 3" length and one 3-3/4" length). Prepare both ends of each cable as follows:

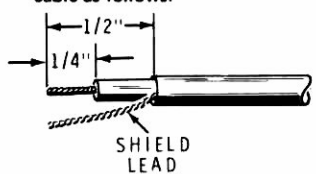

Remove 1/2" of the outer insulation; then remove 1/4" of insulation from the inner conductor. Melt a small amount of solder on the wires at both ends.

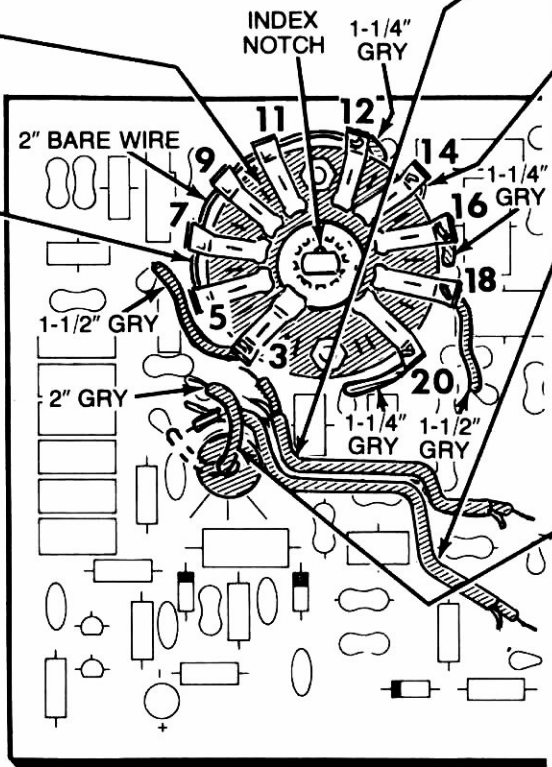
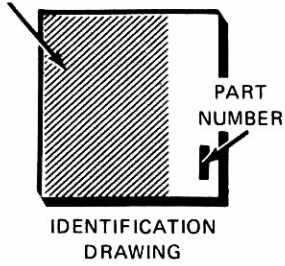

PICTORIAL 7-5

CONTINUE →

- (11) At one end of the 3" cable, connect the shield lead to J (S-1) and the inner lead to H (S-1). Form the lead across the board as shown. Then connect the inner lead to N (S-1) and the shield lead to P (S-1).
- (12) Connect a 3/4" small bare wire between the top and bottom lugs at switch lug 14. Solder both connections.
- (13) In the same manner, at one end of the 3-3/4" cable, connect the shield lead to L (S-1) and the inner lead to K (S-1). Form the lead across the board as shown. Then connect the inner lead to S (S-1) and the shield lead to R (S-1).
- (14) Place a 1-1/2" length of fiber sleeving over a 2" gray wire.
- (15) Connect one end of the 2" gray wire at T (S-1). Pass the free end of this wire down through the eyelet of L813. Connect this end of the wire to hole E on the foil side of the board (S-1). NOTE: This wire must be as short as possible.
- (16) Cut any excess lead lengths from the foil side of the board.

CIRCUIT BOARD CHECKOUT

- Carefully inspect the circuit board for the following conditions.
- (17) Unsoldered connections.
 - (18) "Cold" solder connections.
 - (19) Solder bridges between foils.
 - (20) Protruding leads. No lead should be longer than 1/8".
 - (21) Transistors for the proper type and installation.
 - (22) Electrolytic capacitor for the correct position of the positive (+) end.
 - (23) Diodes for the correct position of the banded end.
 - (24) Lay the circuit board aside. It will be used later.

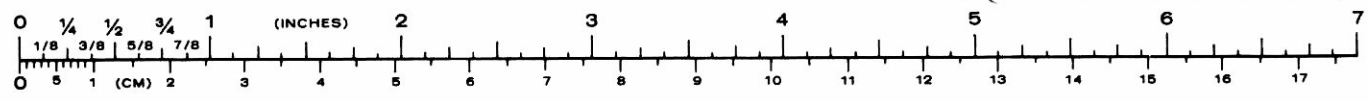

CARRIER GENERATOR/XTAL FILTER CIRCUIT BOARD

PARTS LIST

Remove the parts from Pack #7 and check each part against the following list. Make a check (✓) in the space provided as you identify each part. Any part that is packed in an individual envelope with the part number on it should be placed back in the envelope after you identify it until it is called for in a step. Do not throw away any packing materials until all parts are accounted for.

QTY.	DESCRIPTION	HEATH No.	CIRCUIT Component No.	
()	1	22 Ω (red-red-black)	6-220-12	R605
()	1	47 Ω (yellow-violet-black)	6-470-12	R634
()	12	100 Ω (brown-black-brown)	6-101-12	R601, R607, R618, R619, R621, R622, R626, R627, R633, R636, R645, R655 R665, R667
()	2	270 Ω, 10% (red-violet-brown-silver)	1-21-12	R639, R648, R658
()	3	330 Ω (orange-orange-brown)	6-331-12	R606, R629, R638, R647, R657
()	5	680 Ω (blue-gray-brown)	6-681-12	R609, R663
()	2	1000 Ω (brown-black-red)	6-102-12	R604, R624
()	2	1200 Ω (brown-red-red)	6-122-12	

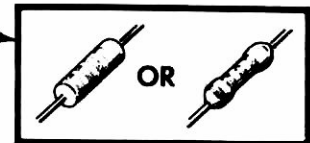

QTY.	DESCRIPTION	HEATH No.	CIRCUIT Component No.
------	-------------	-----------	-----------------------

Resistors, 1/4-Watt (cont'd.)

()	4	1500 Ω (brown-green-red)	6-152-12	R603, R637, R646, R656
()	1	2200 Ω (red-red-red)	6-222-12	R632
()	1	2700 Ω (red-violet-red)	6-272-12	R635
()	6	3300 Ω (orange-orange-red)	6-332-12	R641, R643, R649, R652, R659, R662
()	4	4700 Ω (yellow-violet-red)	6-472-12	R644, R654, R664, R668
()	1	5600 Ω (green-blue-red)	6-562-12	R612
()	4	6800 Ω (blue-gray-red)	6-682-12	R602, R614, R623, R631
()	8	10 kΩ (brown-black-orange)	6-103-12	R611, R615, R617, R640, R642, R651, R653, R661
()	2	22 kΩ (red-red-orange)	6-223-12	R625, R628
()	2	27 kΩ, 10% (red-violet-orange-silver)	1-46-12	R608, R616

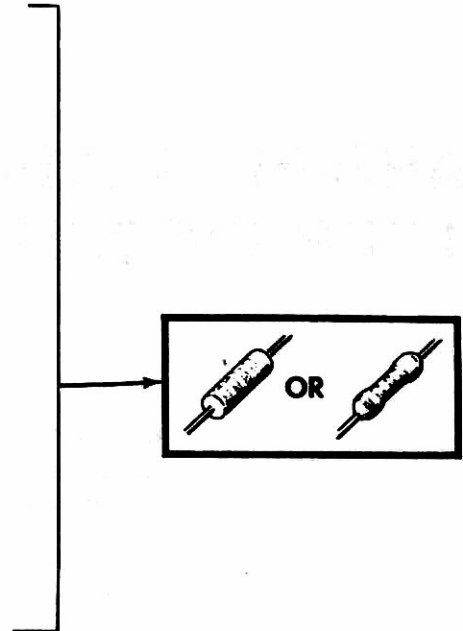

CAPACITORS

Mica

()	1	33 pF	20-160	C645
()	4	56 pF	20-78	C618, C633, C637, C642
()	1	75 pF	20-110	C609
()	4	82 pF	20-141	C613, C634, C638, C643
()	1	94 pF	20-176	C611
()	1	105 pF	20-162	C612
()	1	115 pF	20-124	C624

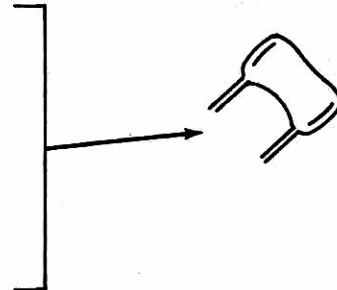

QTY.	DESCRIPTION	HEATH No.	CIRCUIT Component No.
Others			
() 29	.01 μ F disc	21-176	C601, C602, C603, C604, C605, C606, C607, C614, C615, C616, C617, C619, C621, C623, C624, C626, C627, C628, C629, C631, C632, C636, C639, C641, C647, C648, C651, C652, C653
() 1	4.7 μ F tantalum	25-276	C646
() 3	22 μ F tantalum	25-212	C622, C635, C644
() 1	47 μ F tantalum	25-223	C608
() 1	15-60 pF trimmer	31-63	C649
INDUCTORS			
() 1	100 μ H peaking coil	40-486	L605
() 4	37 mH toroid coil	40-1685	L601, L602, L603, L604
() 1	6.5 μ H coil	40-1696	T601
DIODES			
() 8	1N458 (may be marked yellow-green-gray)	56-24	D601, D602, D603, D604, D605, D606, D612, D613
() 4	FH1100	56-87	D607, D608, D609, D611
() 1	GD510	56-89	D614
() 1	1N191 (brown-white-brown)	56-26	D615

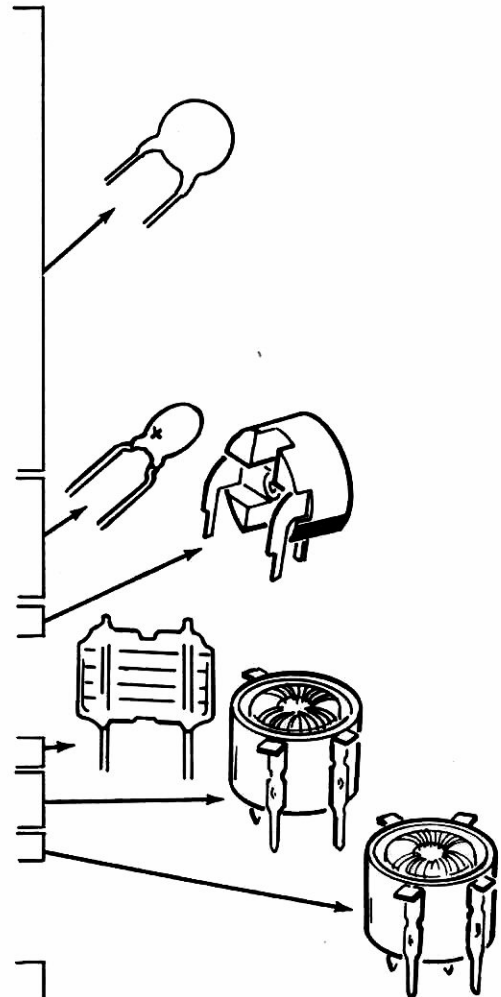

NOTE: HEATH PART NUMBERS ARE STAMPED ON MOST DIODES.

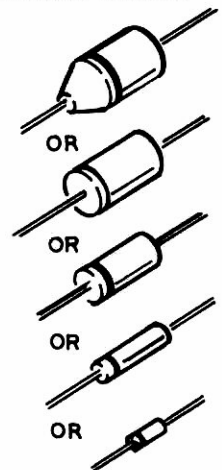

QTY.	DESCRIPTION	HEATH No.	CIRCUIT Component No.
CRYSTALS			
() 1	3393.6 kHz	404-205	Y601
() 1	3396.4 kHz	404-206	Y603
() 1	3395.7 kHz	404-549	Y602
() 1	3395 kHz filter	404-283	FL-601

TRANSISTORS

() 3	X29A829	417-201	Q605, Q609, Q612
() 9	MPSA20	417-801	Q601, Q602, Q603, Q604, Q606, Q607, Q608, Q611, Q613

MISCELLANEOUS

() 1	100 Ω control	10-314	R666
() 2	Board puller	207-80	
() 24	Circuit board connector	432-124	
() 3	Ferrite bead	475-10	
() 2	4-40 nut	252-2	
() 2	#4 lockwasher	254-9	

PARTS FROM PACK #10

() 1	Carrier generator/Xtal filter circuit board	85-1581-6	
-------	---	-----------	--

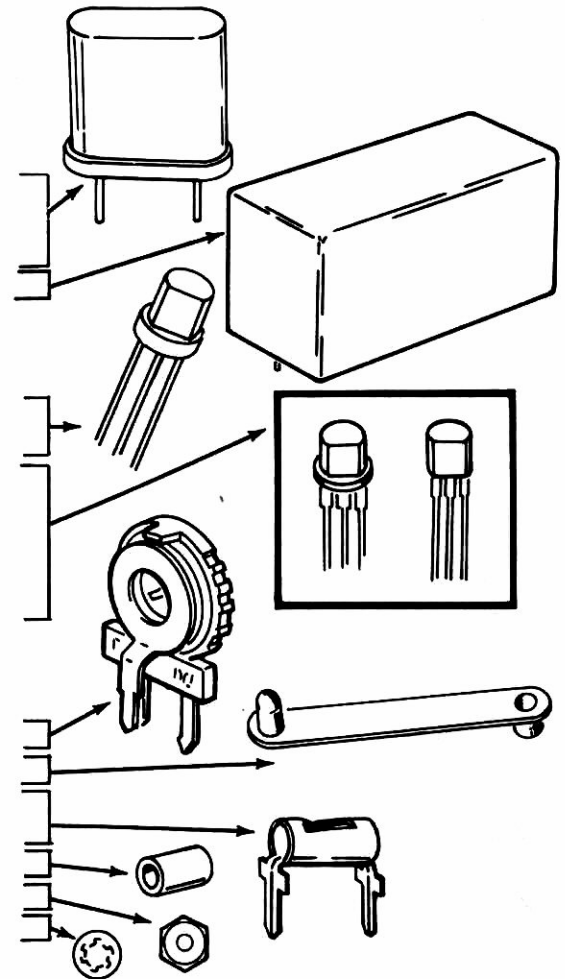

To order a replacement part, always include the PART NUMBER. Use the Parts Order Form furnished with this kit. If one is not available, see "Replacement Parts" inside the rear cover of this Manual. Your Warranty is located inside the front cover. For pricing information, refer to the separate "Heath Parts Price List."

STEP-BY-STEP ASSEMBLY

START

NOTE: The components shown in dashed lines in the Pictorial are printed in yellow on your circuit board. If you intend to install the CW Filter Accessory kit, the parts will be mounted in these spaces.

Position the carrier generator/crystal filter circuit board (#85-1581-6) as shown. Then proceed with the following steps.

Install twenty-four circuit board connectors in the following manner. Note that inside each connector the spring contact is depressed on one end. This depressed end of the connector should face away from the edge of the circuit board. Insert the mounting tabs through the circuit board until the ridges of the connector are firmly against the circuit board. Look at the row of connectors to make sure the depressed end of the contact of each connector is toward the center of the circuit board. Solder the tabs to the foil.

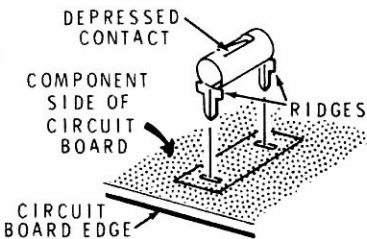

(\) Six circuit board connectors.

() Six circuit board connectors.

) Six circuit board connectors.

(/) Six circuit board connectors.

NOTE: To prepare a wire, cut it to the indicated length and remove 1/4" of insulation from each end.

(\) Prepare a 3-1/4" gray wire.

(/) Connect the wire at J, solder the ends to the foil, and cut off the excess ends.

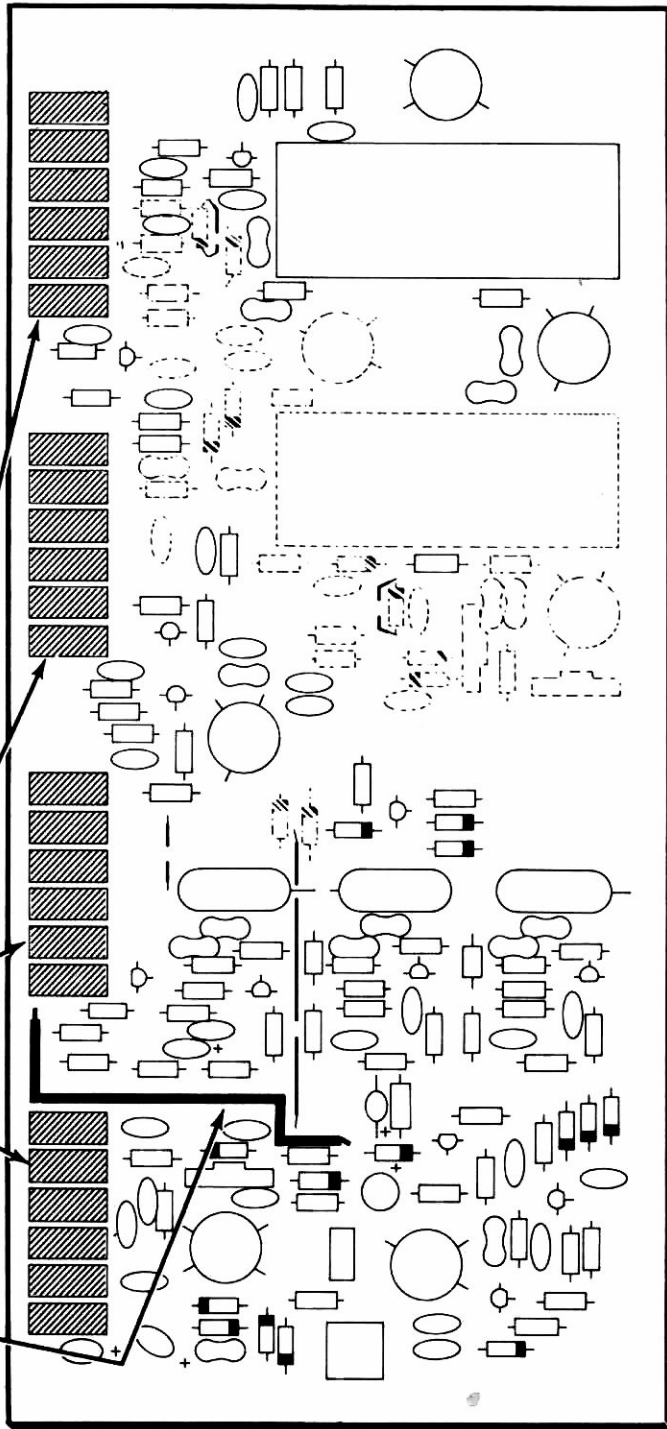

PICTORIAL 8-1

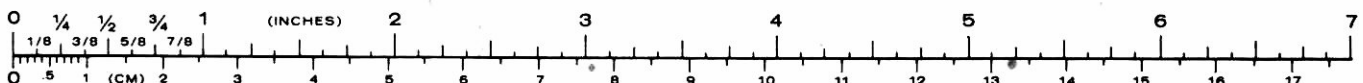

IDENTIFICATION
DRAWING

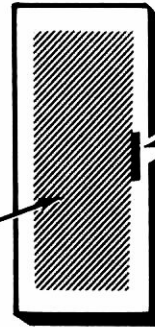

The steps performed in this Pictorial are in this area of the circuit board.

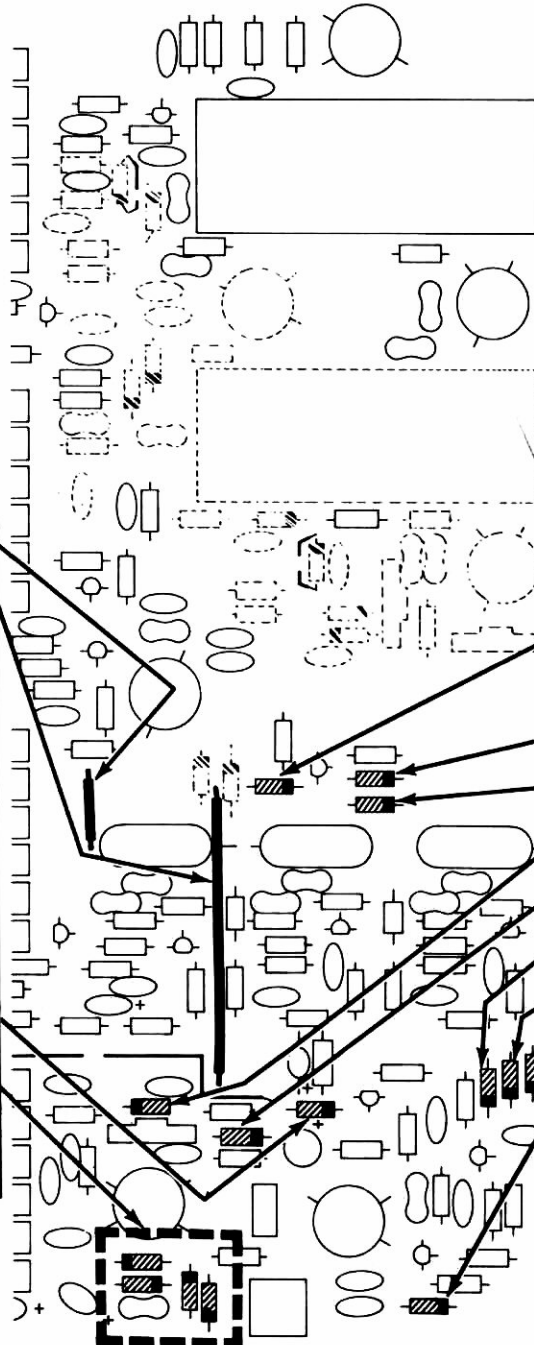

START ▾

- (L) 1" gray jumper wire.
 - (L) 2-3/8" gray jumper wire.
 - (J) Solder the wires to the foil and cut off the excess ends.
- NOTE: When you install a diode, always match the banded end of the diode with the band mark on the circuit board.
-
- (L) D615: 1N191 diode (#56-26, brown-white-brown).
 - (L) D607, D608, D609, D611: Four FH1100 diodes (#56-87).
 - (J) Solder the leads to the foil and cut off the excess lead lengths.

CONTINUE ▾

- (L) D614: GD510 diode (#56-89).
- Install eight 1N458 diodes (#56-24) at:
- (J) D605.
 - (J) D604.
 - (J) D612.
 - (J) D613.
 - (J) D603.
 - (J) D602.
 - (J) D606.
 - (J) D601.
- (J) Solder the leads to the foil and cut off the excess lead lengths.

PICTORIAL 8-2

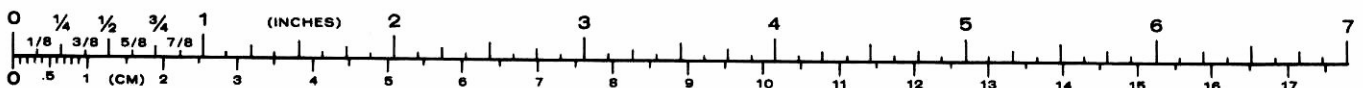

IDENTIFICATION
DRAWING

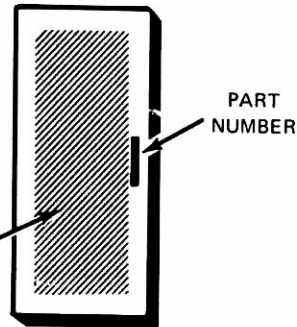

The steps performed in this Pictorial are in this area of the circuit board.

START

- () R602: 6800 Ω (blue-gray-red).
- () R603: 1500 Ω (brown-green-red).
- () R601: 100 Ω (brown-black-brown).
- () R612: 5600 Ω (green-blue-red).
- () R609: 1000 Ω (brown-black-red).
- () R611: 10 kΩ (brown-black-orange).
- () R608: 27 kΩ (red-violet-orange).
- () R607: 100 Ω (brown-black-brown).
- () R618: 100 Ω (brown-black-brown).
- () R616: 27 kΩ (red-violet-orange).
- () R619: 100 Ω (brown-black-brown).
- () Solder the leads to the foil and cut off the excess lead lengths.
- () R621: 100 Ω (brown-black-brown).
- () R624: 1200 Ω (brown-red-red).
- () R623: 6800 Ω (blue-gray-red).
- () R622: 100 Ω (brown-black-brown).
- () R640: 10 kΩ (brown-black-orange).
- () R644: 4700 Ω (yellow-violet-red).
- () R645: 100 Ω (brown-black-brown).
- () R646: 1500 Ω (brown-green-red).
- () R633: 100 Ω (brown-black-brown).
- () R664: 4700 Ω (yellow-violet-red).
- () R668: 4700 Ω (yellow-violet-red).
- () R663: 1000 Ω (brown-black-red).
- () Solder the leads to the foil and cut off the excess lead lengths.

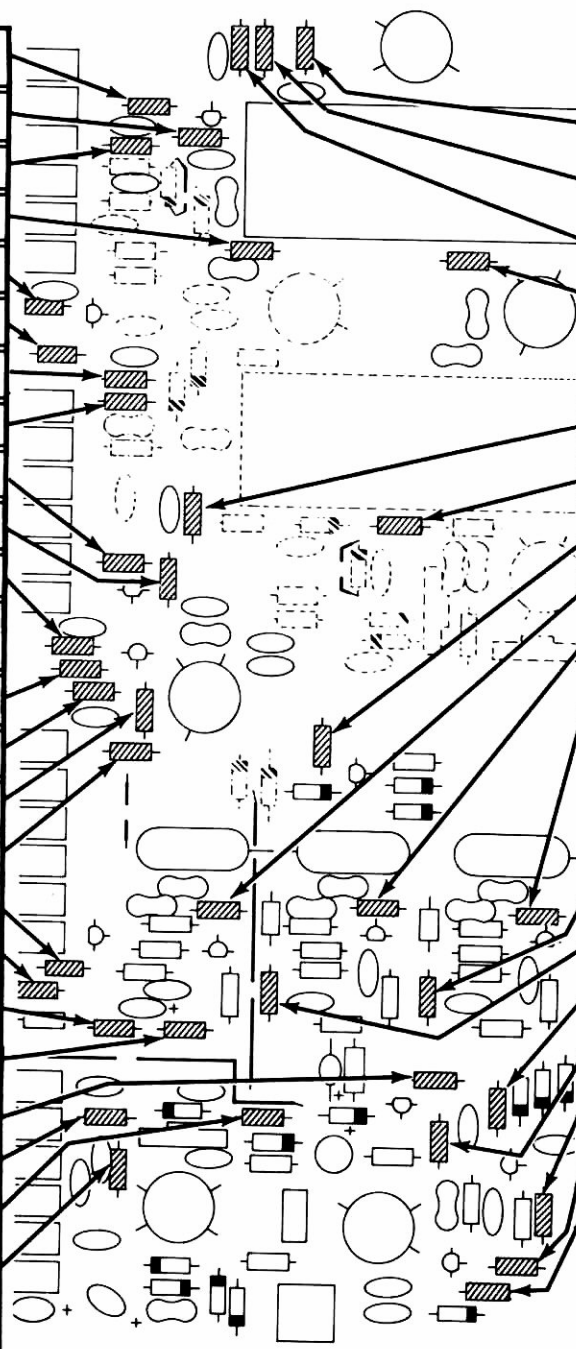

CONTINUE

- () R605: 22 Ω (red-red-black).
- () R606: 680 Ω (blue-gray-brown).
- () R604: 1200 Ω (brown-red-red).
- () R614: 6800 Ω (blue-gray-red).
- Install six 10 kΩ (brown-black-orange) resistors at:
- () R617.
- () R615.
- () R653.
- () R651.
- () R642.
- () R661.
- Solder the leads to the foil and cut off the excess lead lengths.
- Install four 100 Ω (brown-black-brown) resistors at:
- () R655.
- () R636.
- () R626.
- () R627.
- () R628: 22 kΩ (red-red-orange).
- () R632: 2200 Ω (red-red-red).
- () R634: 47 Ω (yellow-violet-black).
- () Solder the leads to the foil and cut off the excess lead lengths.

PICTORIAL 8-3

IDENTIFICATION
DRAWING



PART
NUMBER

The steps performed in this Pictorial are in
this area of the circuit board.

START ↙

Install six 3300 Ω (orange-orange-red)
resistors at:

- () R662.
- () R659.
- () R643.
- () R641.
- () R652.
- () R649.

() R648: 330 Ω (orange-orange-brown).

() R639: 330 Ω (orange-orange-brown).

() R647: 680 Ω (blue-gray-brown).

() R667: 270 Ω (red-violet-brown).

() R665: 270 Ω (red-violet-brown).

() Solder the leads to the foil and cut
off the excess lead lengths.

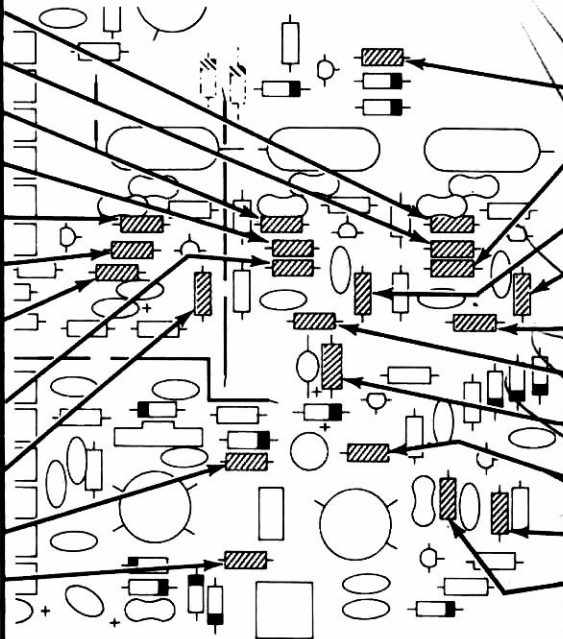

CONTINUE ↘

() R654: 4700 Ω (yellow-violet-red).

() R658: 330 Ω (orange-orange-brown).

() R638: 680 Ω (blue-gray-brown).

() R657: 680 Ω (blue-gray-brown).

() R656: 1500 Ω (brown-green-red).

() R637: 1500 Ω (brown-green-red).

() R625: 22 kΩ (red-red-orange).

() R635: 2700 Ω (red-violet-red).

() R629: 680 Ω (blue-gray-brown).

() R631: 6800 Ω (blue-gray-red).

() Solder the leads to the foil and cut
off the excess lead lengths.

PICTORIAL 8-4

IDENTIFICATION
DRAWING

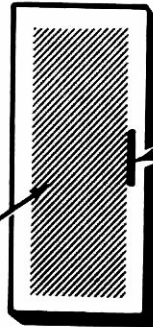

PART
NUMBER

The steps performed in this Pictorial are in
this area of the circuit board.



START ↘

- Install seven .01 μ F disc capacitors at:
- () C602.
 - () C603.
 - () C601.
 - () C604.
 - () C605.
 - () C606.
 - () C607.

() Solder the leads to the foil and cut off the excess lead lengths.

- Install six .01 μ F disc capacitors at:
- () C616.
 - () C615.
 - () C617.
 - () C614.
 - () C619.
 - () C621.

() Solder the leads to the foil and cut off the excess lead lengths.

- Install seven .01 μ F disc capacitors at:
- () C636.
 - () C652.
 - () C648.
 - () C628.
 - () C651.
 - () C647.
 - () C653.

() Solder the leads to the foil and cut off the excess lead lengths.

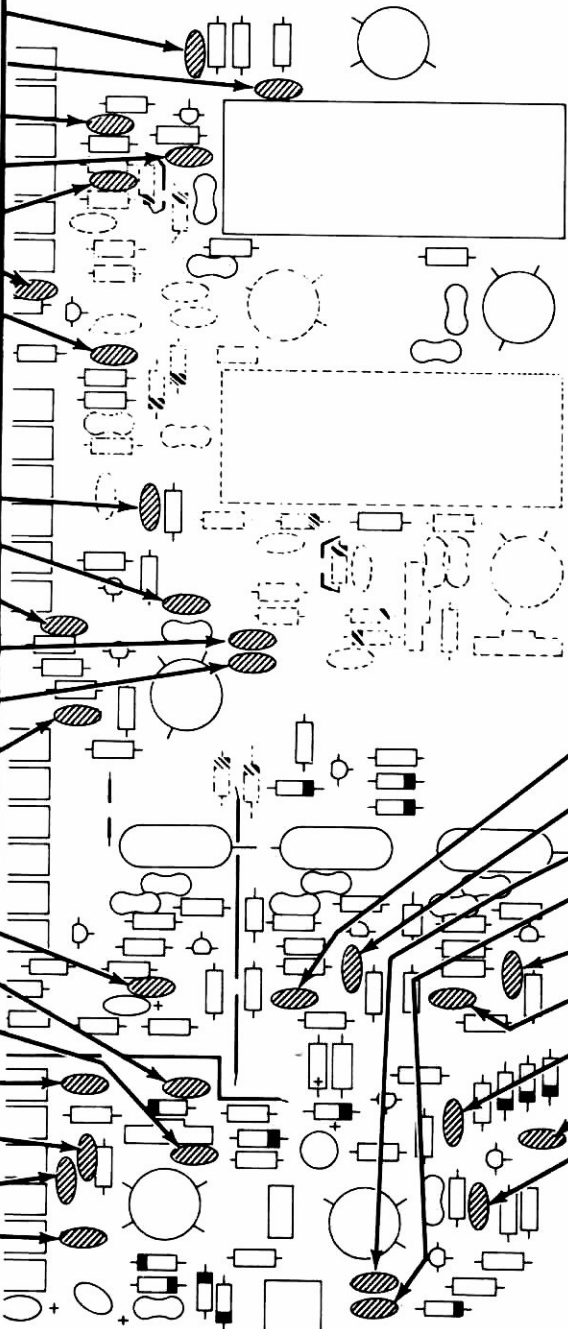

CONTINUE ↘

- Install nine .01 μ F disc capacitors at:
- () C631.
 - () C632.
 - () C627.
 - () C629.
 - () C641.
 - () C639.
 - () C626.
 - () C623.
 - () C624.

() Solder the leads to the foil and cut off the excess lead lengths.

PICTORIAL 8-5

IDENTIFICATION
DRAWING

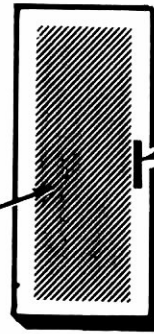

The steps performed in this Pictorial are in this area of the circuit board.

START

NOTE: When you install a ferrite bead, use a 1" small bare wire to mount the bead to the circuit board.

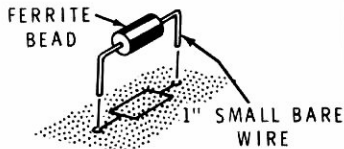

- 1) Ferrite bead.
- 2) Ferrite bead.
- 3) Ferrite bead.

NOTE: When you install tantalum capacitors, be sure to match the positive (+) mark or color dot on the capacitor with the positive (+) mark on the circuit board as shown.

MAY BE MARKED WITH POSITIVE (+) SIGN OR COLOR DOT.

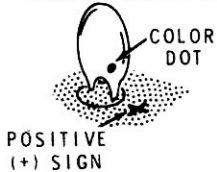

- 4) C635: 22 μ F tantalum.
- 5) C622: 22 μ F tantalum.
- 6) C608: 47 μ F tantalum.
- 7) C644: 22 μ F tantalum.
- 8) C646: 4.7 μ F tantalum.
- 9) Solder the leads to the foil and cut off the excess lead lengths.

CONTINUE

- 10) C611: 94 pF mica.
- 11) C609: 75 pF mica.
- 12) C612: 105 pF mica.
- 13) C613: 82 pF mica.
- 14) C618: 56 pF mica.
- 15) Solder the leads to the foil and cut off the excess lead lengths.
- 16) C637: 56 pF mica.
- 17) C638: 82 pF mica.
- 18) C633: 56 pF mica.
- 19) C634: 82 pF mica.
- 20) C642: 56 pF mica.
- 21) C643: 82 pF mica.
- 22) C645: 33 pF mica.
- 23) C625: 115 pF mica.
- 24) Solder the leads to the foil and cut off the excess lead lengths.
- 25) C649: 15-60 pF trimmer. Solder the leads to the foil.

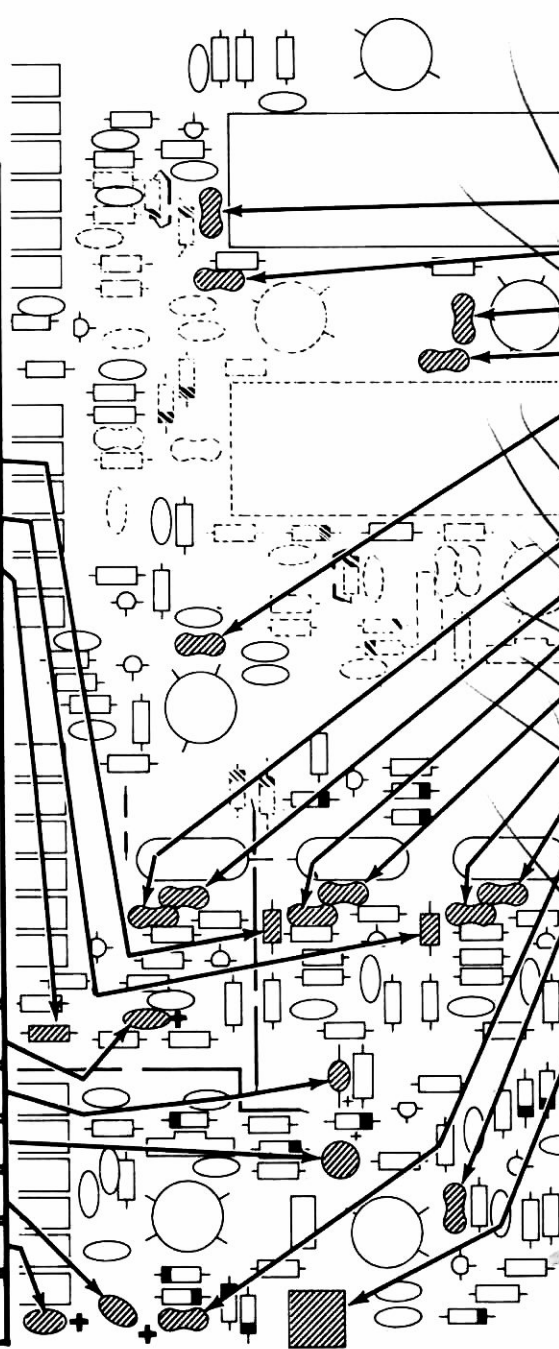

PICTORIAL 8-6

IDENTIFICATION
DRAWING

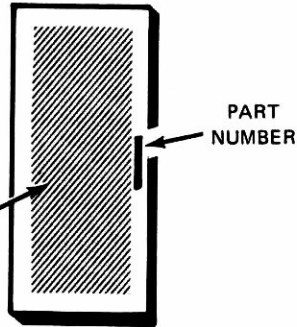

The steps performed in this Pictorial are in this area of the circuit board.

START ▾

NOTE: Install the following transistors in the manner shown. First line up the flat of the transistor with the outline of the flat on the circuit board. Insert the transistor leads into their correct holes indicated by E, B, and C. Solder each lead to the foil and cut off the excess lead length.

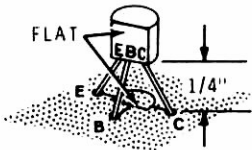

Install nine MPSA20 transistors (#417-801) at:

- () Q603.
- () Q604.
- () Q602.
- () Q601.
- () Q611.
- () Q608.
- () Q613.
- () Q606.
- () Q607.

CONTINUE ▾

NOTE: Install the following transistors in the manner shown. First line up the flat of the transistor with the outline of the flat on the circuit board. Bend the center lead back away from the flat. Insert the transistor leads into their correct holes indicated by E, C, and B. Solder each lead to the foil and cut off the excess lead lengths.

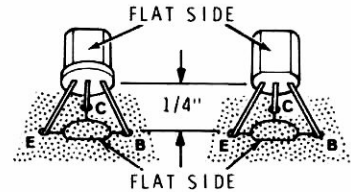

Install three X29A829 transistors (#417-201) at:

- () Q612.
- () Q609.
- () Q605.

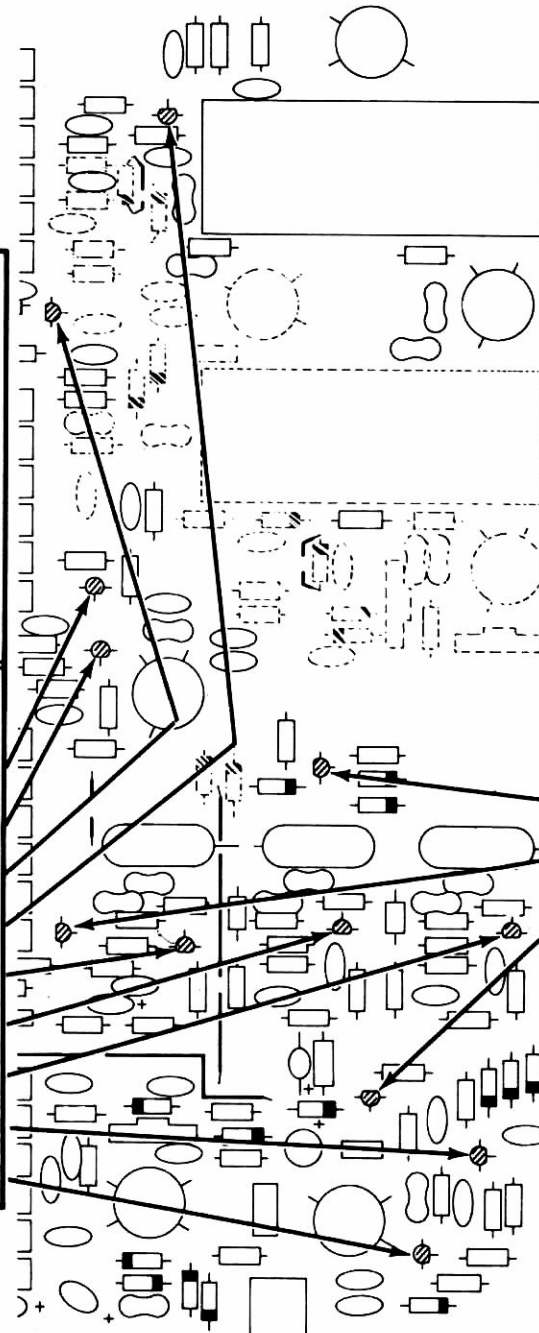

PICTORIAL 8-7

IDENTIFICATION
DRAWING

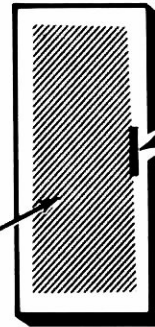

PART
NUMBER

The steps performed in this Pictorial are in this area of the circuit board.

CONTINUE

Mount the 2.1 kHz SSB crystal filter (#404-283) with #4 lockwashers and 4-40 nuts. Then solder the lugs to the foil. The filter can be installed either way.

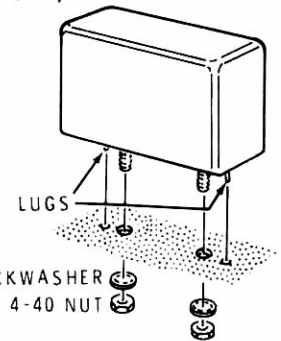

NOTE: The following crystal frequencies (as well as the component numbers) are screened on the circuit board. Be sure you mount each crystal in its correct location. Then solder the three leads to the foil.

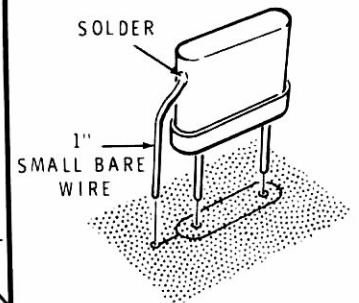

Solder a 1" length of small bare wire to each crystal.

Y603: 3396.4 MHz crystal (#404-206).

Y601: 3393.6 MHz crystal (#404-205).

Y602: 3395.7 MHz crystal (#404-549).

START

Install four coils (#40-1685). Solder the leads to the foil.

- () L601.
- () L602.
- () L603.
- () L604.

L605: 100 μ H peaking coil (brown-black-brown). Solder the leads to the foil.

T601: Transformer (#40-1696). Solder the leads to the foil. This coil can be installed either way.

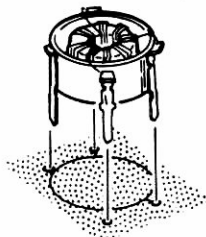

R666: 100 Ω control (#10-314). Solder the leads to the foil and cut off the excess lead lengths.

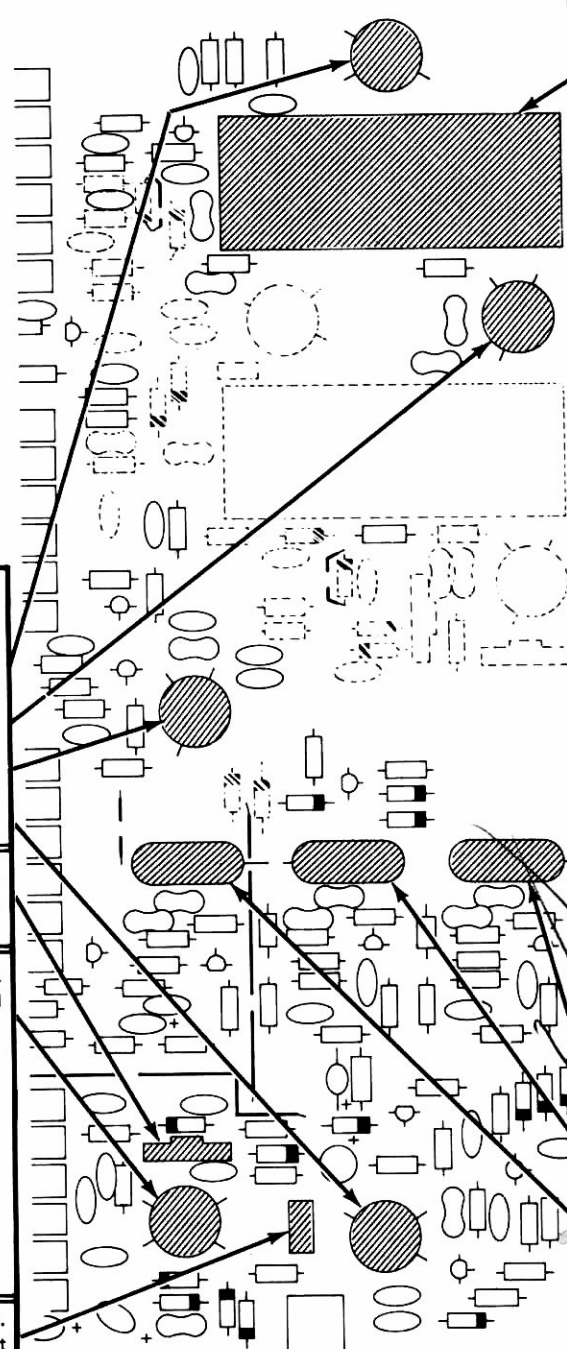

PICTORIAL 8-3

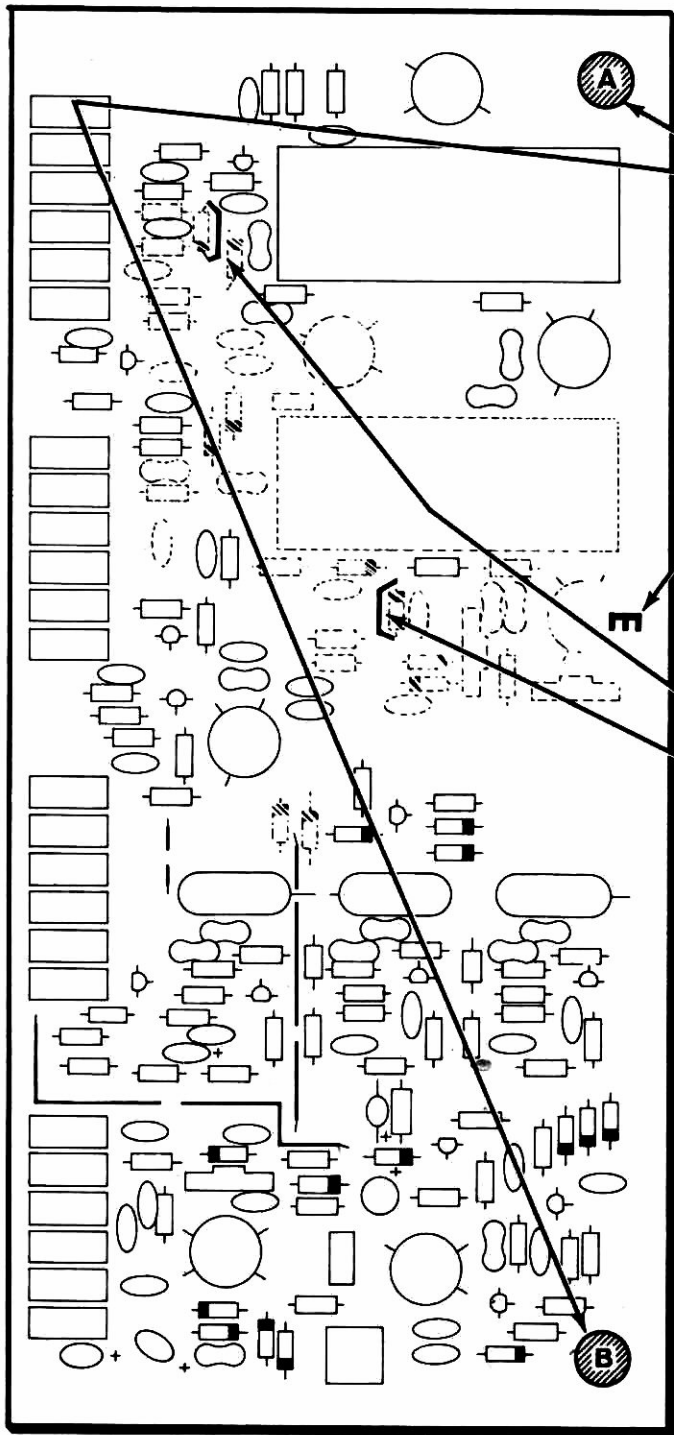

START

Mount board pullers on the foil side of the circuit board at holes A and B. Position the female part in the circuit board; then push the male part through the female part.

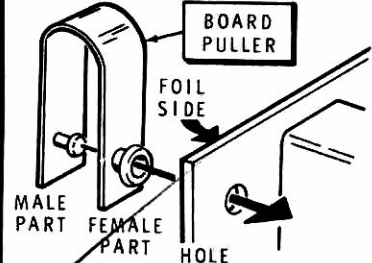

Cut a letter "E" from the terminal identification sheet and remove the adhesive backing. Press the letter onto the circuit board at the location shown.

NOTE: If you have purchased the CW Filter Accessory kit, it should be installed on this circuit board now and the two following steps should be disregarded. **IMPORTANT:** If you are not installing the CW Filter Accessory kit now, it is **ESSENTIAL** that you install the two jumper wires in the following steps:

- (/) 3/4" small bare jumper wire.
- () 3/4" small bare jumper wire.

CIRCUIT BOARD CHECKOUT

Carefully inspect the circuit board for the following conditions.

- (-) Unsoldered connections.
- () "Cold" solder connections.
- () Solder bridges between foils.
- () Protruding leads. No lead should be longer than 1/8".
- () Transistors for the proper type and installation.
- () Electrolytic capacitors for the correct position of the positive (+) end.
- () Diodes for the correct position of the banded end.
- () Lay the circuit board aside. It will be used later.

FINISH



PICTORIAL 8-9

RECEIVER IF/AUDIO CIRCUIT BOARD

PARTS LIST

Remove the parts from Pack #8 and check each part against the following list. Make a check (✓) in the space provided as you identify each part. Any part that is packed in an individual envelope with the part number on it should be placed back in the envelope after you identify it until it is called for in a step. Do not throw away any packing materials until all parts are accounted for.

QTY.	DESCRIPTION	HEATH No.	CIRCUIT Component No.
RESISTORS			
1/2-Watt			
() 1	47 Ω (yellow-violet-black)	6-470	R504
() 14	100 Ω (brown-black-brown)	6-101	R501, R506, R508, R509, R515, R522, R528, R536, R543, R544, R551, R553, R559, R563
() 1	150 Ω (brown-green-brown)	6-151	R558
() 1	270 Ω (red-violet-brown)	6-271	R505
() 2	470 Ω (yellow-violet-brown)	6-471	R519, R531
() 3	620 Ω (blue-red-brown)	6-621	R514, R525, R579
() 2	820 Ω (gray-red-brown)	6-821	R502, R529

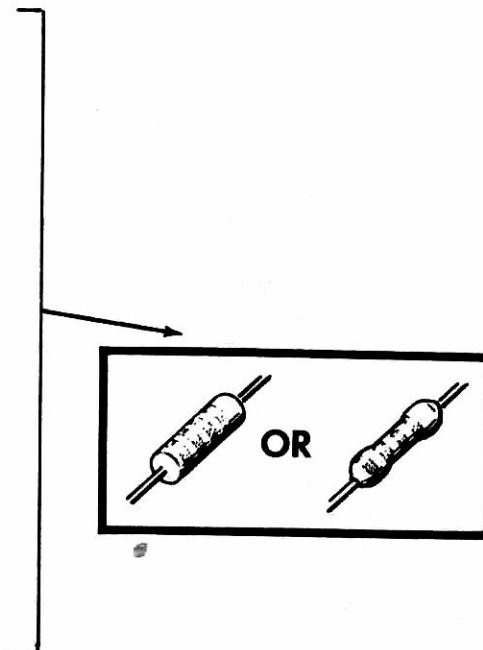

QTY.	DESCRIPTION	HEATH No.	CIRCUIT Component No.
RESISTORS (cont'd.)			
() 4	1000 Ω (brown-black-red)	6-102	R521, R552, R555, R556
() 3	1500 Ω (brown-green-red)	6-152	R503, R541, R557
() 2	1800 Ω (brown-gray-red)	6-182	R578, R582
() 2	2400 Ω (red-yellow-red)	6-242	R513, R523
() 3	2700 Ω (red-violet-red)	6-272	R517, R524, R542
() 1	3300 Ω (orange-orange-red)	6-332	R538
() 1	3900 Ω (orange-white-red)	6-392	R537
() 3	4700 Ω (yellow-violet-red)	6-472	R512, R533, R572
() 1	6800 Ω (blue-gray-red)	6-682	R549
() 1	8200 Ω (gray-red-red)	6-822	R526
() 1	10 kΩ (brown-black-orange)	6-103	R518
() 3	15 kΩ (brown-green-orange)	6-153	R507, R511, R554
() 1	22 kΩ (red-red-orange)	6-223	R574
() 2	33 kΩ (orange-orange-orange)	6-333	R547, R548
() 1	39 kΩ (orange-white-orange)	6-393	R516
() 1	91 kΩ (white-brown-orange)	6-913	R571
() 3	100 kΩ (brown-black-yellow)	6-104	R539, R565, R568
() 1	120 kΩ, 10% (brown-red-yellow-silver)	1-121	R527
() 1	150 kΩ (brown-green-yellow)	6-154	R573
() 2	180 kΩ (brown-gray-yellow)	6-184	R566, R567
() 1	330 kΩ (orange-orange-yellow)	6-334	R564
() 1	390 kΩ (orange-white-yellow)	6-394	R575
() 1	820 kΩ (gray-red-yellow)	6-824	R545
() 1	1.5 MΩ (brown-green-green)	6-155	R576
() 1	1.8 MΩ (brown-gray-green)	6-185	R581
() 1	3.3 MΩ (orange-orange-green)	6-335	R577
() 1	5.6 MΩ, 10% (green-blue-green-silver)	1-86	R546

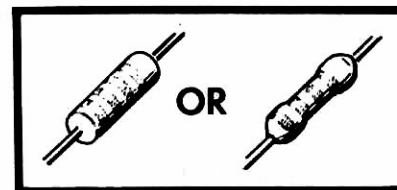

QTY.	DESCRIPTION	HEATH No.	CIRCUIT Component No.
Other Resistors			
() 1	.82 Ω , 2-watt (gray-red-silver-gold)	3-1-2	R532
() 1	1755 (1.755 k) Ω , 1%, .12 watt	2-5-11	R562
() 1	20 k Ω , 1%, 1/4-watt	2-68-12	R561
CAPACITORS			
Mica			
() 1	130 pF	20-104	C509
() 1	160 pF	20-178	C505
() 1	270 pF	20-114	C544
() 1	820 pF	20-171	C543
Disc			
() 5	.001 μ F	21-140	C523, C524, C546, C547, C551
() 25	.01 μ F	21-176	C501-C504, C506-C508, C511-C517, C519, C521, C522, C532-C534, C536-C539, C553
() 2	.05 μ F	21-143	C528, C552
() 1	.1 μ F	21-95	C545
Mylar			
() 1	.68 μ F Mylar	27-62	C542
Electrolytic			
() 1	.68 μ F	25-922	C548
() 1	2.2 μ F	25-924	C535
() 2	10 μ F	25-115	C518, C549
() 5	100 μ F	25-248	C525, C526, C527, C529, C541
() 1	500 μ F	25-157	C531
INDUCTORS			
() 1	Toroid coil	40-1686	L501
() 1	Toroid coil	40-1687	T501
() 1	Toroid bifilar coil	40-1688	T502
() 2	Ferrite bead	475-10	FB

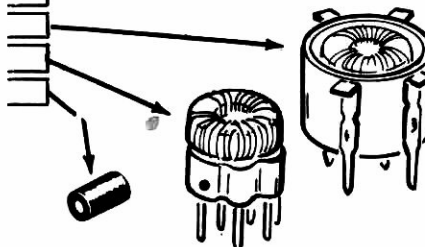
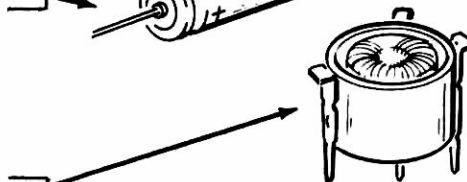
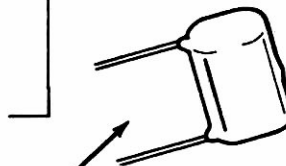
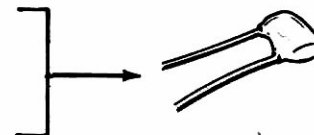
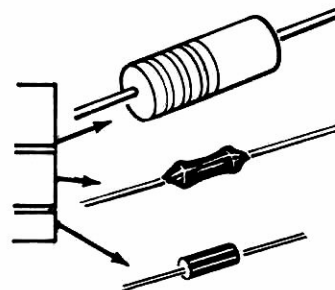

QTY.	DESCRIPTION	HEATH No.	CIRCUIT Component No.
DIODES			
() 1	1N710 zener	56-6	ZD501
() 9	1N4149	56-56	D501-D505, D511-D514
() 1	1N750A	56-59	ZD502
() 4	FH1100	56-87	D506-D509

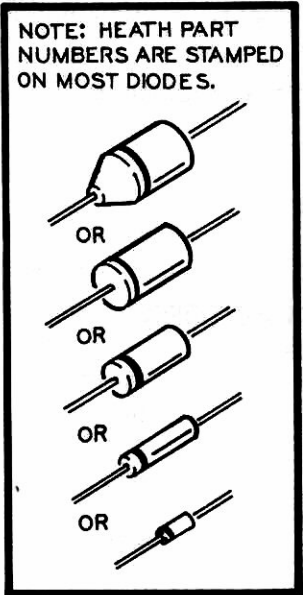

TRANSISTORS

() 9	MPSA20	417-801	Q502-Q505, Q507-Q509, Q512, Q514
() 1	2N3643	417-233	Q515
() 1	2N3638A	417-234	Q517
() 3	2N4121	417-235	Q506, Q511, Q513
() 1	40673	417-274	Q501
() 1	SJE607	417-263	Q516
() 1	SJE608	417-264	Q518

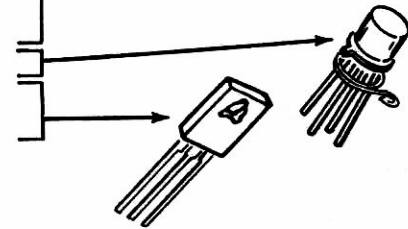
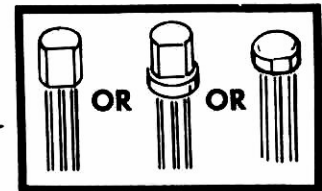

INTEGRATED CIRCUIT

() 1	MC1350P	442-18	IC501
() 1	LM3900	442-71	IC502

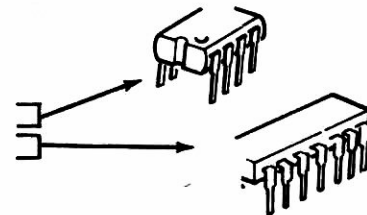

QTY.	DESCRIPTION	HEATH No.	CIRCUIT Component No.
MISCELLANEOUS			
() 1	5000 Ω control	10-311	R534
() 2	Board puller	207-80	
() 2	Heat sink	215-53	
() 1	14-pin socket	434-289	
() 1	8-pin socket	434-230	
() 24	Circuit board connector	432-124	
() 2	4-40 x 1/4" screw	250-52	
() 2	4-40 nut	252-2	
() 2	#4 lockwasher	254-9	

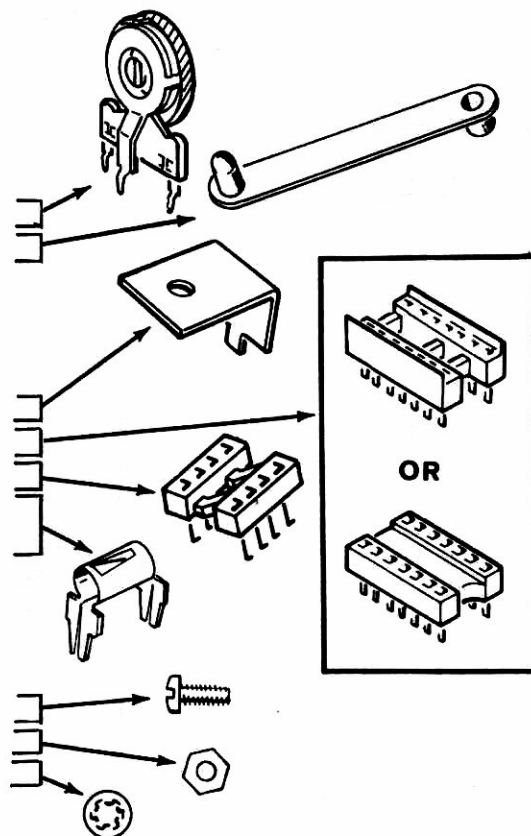
PART FROM PACK #10

() 1	Receiver IF audio circuit board	85-1462-6
-------	---------------------------------	-----------

To order a replacement part, always include the PART NUMBER. Use the Parts Order Form furnished with this kit. If one is not available, see "Replacement Parts" inside the rear cover of this Manual. Your Warranty is located inside the front cover. For pricing information, refer to the separate "Heath Parts Price List."

STEP-BY-STEP ASSEMBLY

The steps performed in this Pictorial are in this area of the circuit board.

START

Position the receiver IF audio circuit board #85-1462-6) as shown.

- Install twenty-four circuit board connectors in the following manner. Note that inside each connector the spring contact is depressed on one end. This depressed end of the connector must face away from the edge of the circuit board. Insert the mounting tabs through circuit board until the ridges of the connectors are firmly against the circuit board. Look at the row of connectors to make sure the depressed end of the contact of each connector is toward the center of the circuit board. Solder the tabs to the foil.

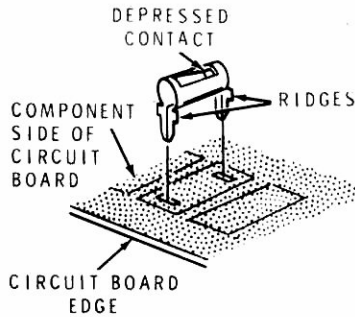

IDENTIFICATION DRAWING

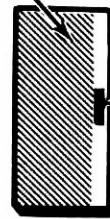

PART NUMBER

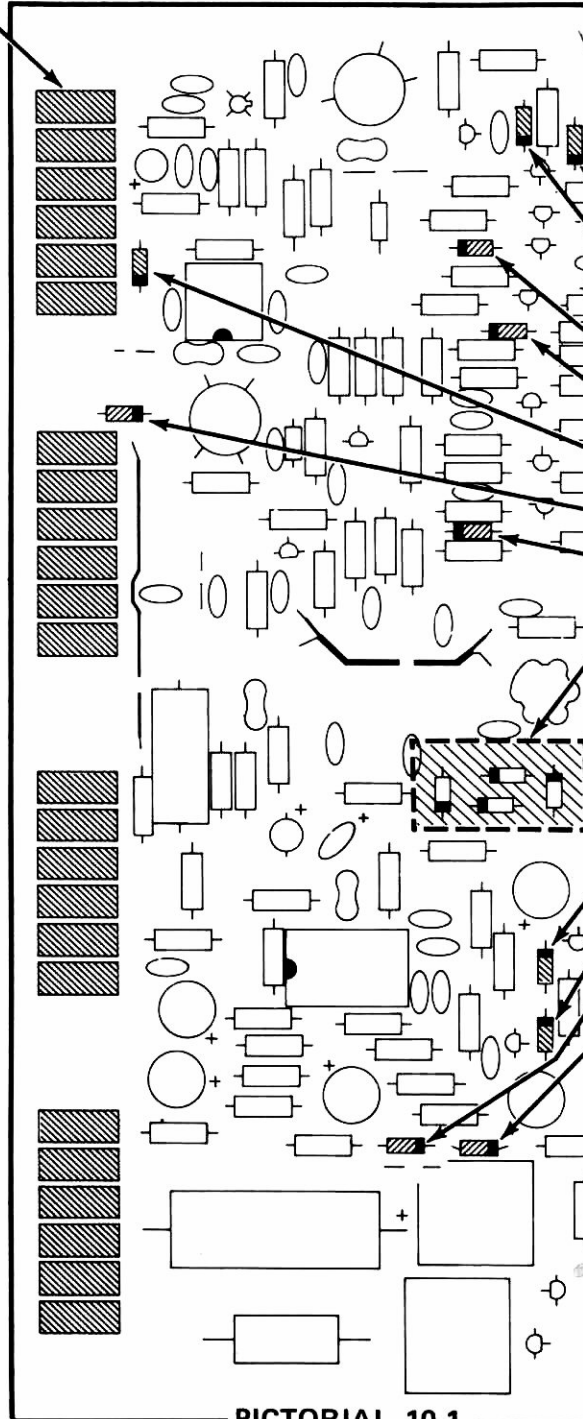

CONTINUE

NOTE: When you install a diode, always match the banded end of the diode with the band mark on the circuit board.

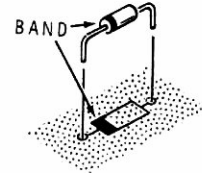

() ZD502: 1N750A (#56-59).

() ZD501: 1N710 (#56-6) diode.

Install five 1N4149 (#56-56) diodes at:

- () D504.
- () D501.
- () D505.
- () D503.
- () D502.

() D506-D509: Four FH1100 (#56-87) diodes.

() Solder all leads to the foil and cut off the excess lead lengths.

Install four 1N4149 (#56-56) diodes at:

- () D514.
- () D513.
- () D511.
- () D512.

() Solder all leads to the foil and cut off the excess lead lengths.

The steps performed in this Pictorial are in this area of the circuit board.

IDENTIFICATION DRAWING

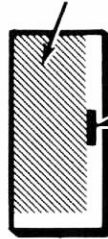

PART NUMBER

START

CONTINUE

- (✓) R505: 270 Ω (red-violet-brown).
- (✓) R504: 47 Ω (yellow-violet-black).
- (✓) R502: 820 Ω (gray-red-brown).
- (✓) R503: 1500 Ω (brown-green-red).
- (✓) R501: 100 Ω (brown-black-brown).
- (✓) R513: 2400 Ω (red-yellow-red).
- (✓) R514: 620 Ω (blue-red-brown).
- (✓) R517: 2700 Ω (red-violet-red).
- (✓) R519: 470 Ω (yellow-violet-brown).
- (✓) Solder the leads to the foil and cut off the excess lead lengths.
- (✓) R566: 180 kΩ (brown-gray-yellow).
- (✓) R568: 100 kΩ (brown-black-yellow).
- (✓) R567: 180 kΩ (brown-gray-yellow).
- (✓) R564: 330 kΩ (orange-orange-yellow).
- (✓) R565: 100 kΩ (brown-black-yellow).
- (✓) R563: 100 Ω (brown-black-brown).
- (✓) R581: 1.8 MΩ (brown-gray-green). NOTE: Your circuit board may be screened 100 k.
- (✓) R573: 150 kΩ (brown-green-yellow).
- (✓) R571: 91 kΩ (white-brown-orange).
- (✓) R525: 620 Ω (blue-red-brown).
- (✓) R528: 100 Ω (brown-black-brown).
- (✓) Solder all leads to the foil and cut off the excess lead lengths.

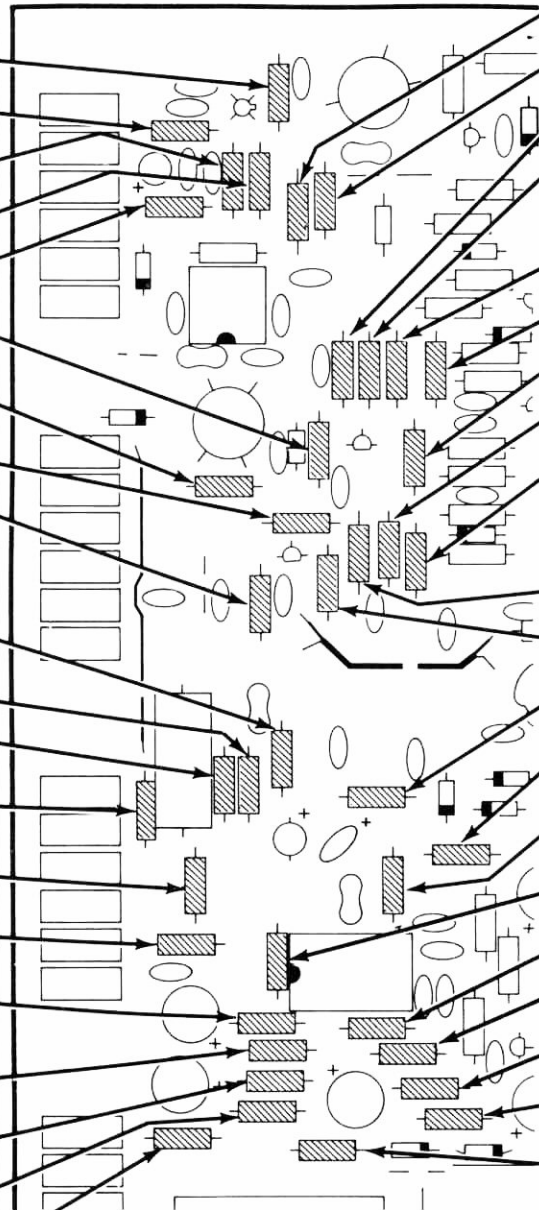

- (✓) R506: 100 Ω (brown-black-brown).
- (✓) R508: 100 Ω (brown-black-brown).
- (✓) R511: 15 kΩ (brown-green-orange).
- (✓) R512: 4700 Ω (yellow-violet-red).
- Five 100 Ω (brown-black-brown) at:
- (✓) R509.
- (✓) R551.
- (✓) R553.
- (✓) R515.
- (✓) R559.
- (✓) Solder the leads to the foil and cut off the excess lead lengths.
- (✓) R516: 39 kΩ (orange-white-orange).
- (✓) R518: 10 kΩ (brown-black-orange).
- (✓) R522: 100 Ω (brown-black-brown).
- (✓) R575: 390 kΩ (orange-white-yellow).
- (✓) R576: 1.5 MΩ (brown-green-green).
- (✓) R577: 3.3 MΩ (orange-orange-green).
- (✓) R572: 4700 Ω (yellow-violet-red).
- (✓) R574: 22 kΩ (red-red-orange).
- (✓) R527: 120 kΩ (brown-red-yellow).
- (✓) R526: 8200 Ω (gray-red-red).
- (✓) R528: 2400 Ω (red-yellow-red).
- (✓) Solder all leads to the foil and cut off the excess lead lengths.

PICTORIAL 10-2

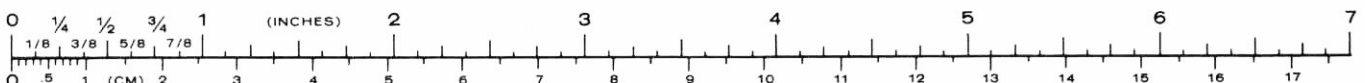

START →

- (✓) R541: 1500 Ω (brown-green-red).
- (✓) R533: 4700 Ω (yellow-violet-red).
- (✓) R537: 3900 Ω (orange-white-red).
- (✓) Form the leads of a 15 kΩ (brown-green-orange) resistor as shown. Then cut each lead of a .01 μF disc capacitor to 1/2" and wrap the capacitor leads around the resistor leads. Solder the leads together as shown.
- (✓) R507/C553: Resistor-capacitor combination. NOTE: Your circuit board may be screened 4700 at this location.
- (✓) R536: 100 Ω (brown-black-brown).
- (✓) R543: 100 Ω (brown-black-brown).
- (✓) R545: 820 kΩ (gray-red-yellow).
- (✓) R547: 33 kΩ (orange-orange-orange).
- (✓) R552: 1000 Ω (brown-black-red).
- (✓) R554: 15 kΩ (brown-green-orange).
- (✓) R555: 1000 Ω (brown-black-red).
- (✓) R556: 1000 Ω (brown-black-red).
- (✓) R561: 20 kΩ, 1%.



FOR GOOD SOLDER CONNECTIONS, YOU MUST KEEP THE SOLDERING IRON TIP CLEAN.
WIPE IT OFTEN WITH A DAMP SPONGE OR CLOTH.

(✓) Solder all leads to the foil and cut off the excess lead lengths.

The steps performed in this Pictorial are in this area of the circuit board.

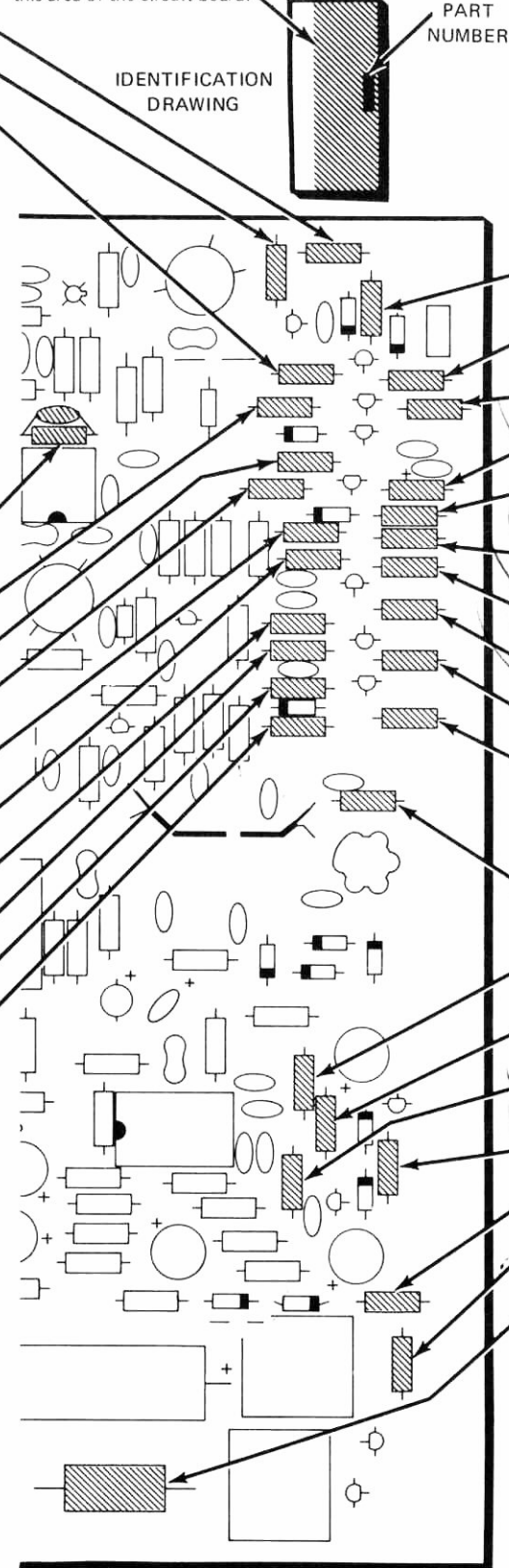

CONTINUE →

- (✓) R538: 3300 Ω (orange-orange-red).
- (✓) R539: 100 kΩ (brown-black-yellow).
- (✓) R542: 2700 Ω (red-violet-red).
- (✓) R544: 100 Ω (brown-black-brown).
- (✓) R546: 5.6 MΩ (green-blue-green).
- (✓) R548: 33 kΩ (orange-orange-orange).
- (✓) R549: 6800 Ω (blue-gray-red).
- (✓) R557: 1500 Ω (brown-green-red).
- (✓) R558: 150 Ω (brown-green-brown).
- (✓) R562: 1755 (1.755 k) Ω, 1%.
- (✓) Solder all leads to the foil and cut off the excess lead lengths.
- (✓) R521: 1000 Ω (brown-black-red).
- (✓) R578: 1800 Ω (brown-gray-red). NOTE: Your circuit board may be screened 330.
- (✓) R582: 1800 Ω (brown-gray-red).
- (✓) R579: 620 Ω (blue-red-brown).
- (✓) R531: 470 Ω (yellow-violet-brown).
- (✓) R534: 2700 Ω (red-violet-red).
- (✓) R529: 820 Ω (gray-red-brown).
- (✓) R532: .82 Ω (gray-red-silver-gold).
- (✓) Solder the leads to the foil and cut off the excess lead lengths.

PICTORIAL 10-3

The steps performed in this Pictorial are in this area of the circuit board.

IDENTIFICATION DRAWING

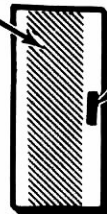

PART NUMBER

CONTINUE

NOTE: To install an IC socket, insert the socket pins into the holes. The half-moon mark on the circuit board should still be visible after it is installed. Solder the pins to the foil. **OR**

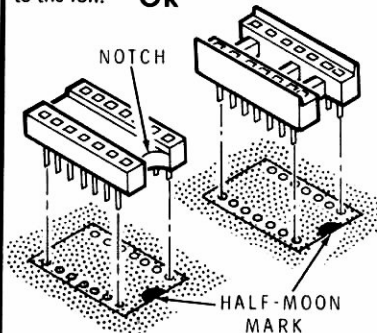

NOTE: Before you install an IC, first be sure the pins are straight. Then lay it down on one of its rows of pins, as shown below at A, and roll it over until the pins are at right angles or are bent in slightly as shown at B. Repeat this process for the other row of pins.



To install an IC, position the pin 1 end toward the half-moon mark on the circuit board (see Detail 4-7A on Page 63). Then carefully install the IC. Make sure all the pins are in their respective holes.

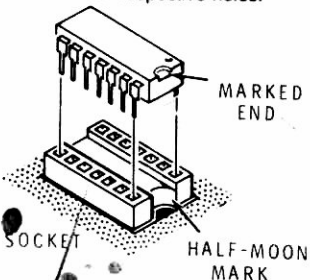

(*) 8-pin IC socket at IC501. Solder each pin to the foil.

(*) IC501: MC1350P IC (#442-18).

(*) 14-pin IC socket at IC502. Solder each pin to the foil.

(*) IC502: LM3900 IC (#442-71).

START

(*) 1" small bare wire.

(*) Ferrite bead.

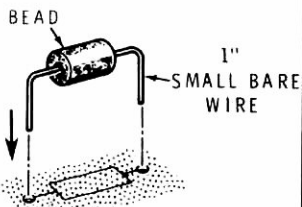

(*) Ferrite bead.

(*) 1" small bare wire.

(*) 1" small bare wire.

(*) 2-1/2" gray wire. Remove 1/4" insulation from each end.

(*) Prepare both ends of a 2" length of shielded cable as shown. Melt a small amount of solder on the wires at each end.

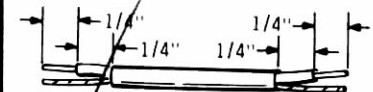

(*) Prepared shielded cable. Center conductor at one end to hole A and the shield wires to B. At the other end, center conductor to C and the shield wires to D. Solder the cable as it is installed.

(*) 1" small bare wire.

FOR GOOD SOLDER CONNECTIONS, YOU MUST KEEP THE SOLDERING IRON TIP CLEAN.

WIPE IT OFTEN WITH A DAMP SPONGE OR CLOTH.



(*) Solder all leads to the foil and cut off the excess lead lengths.

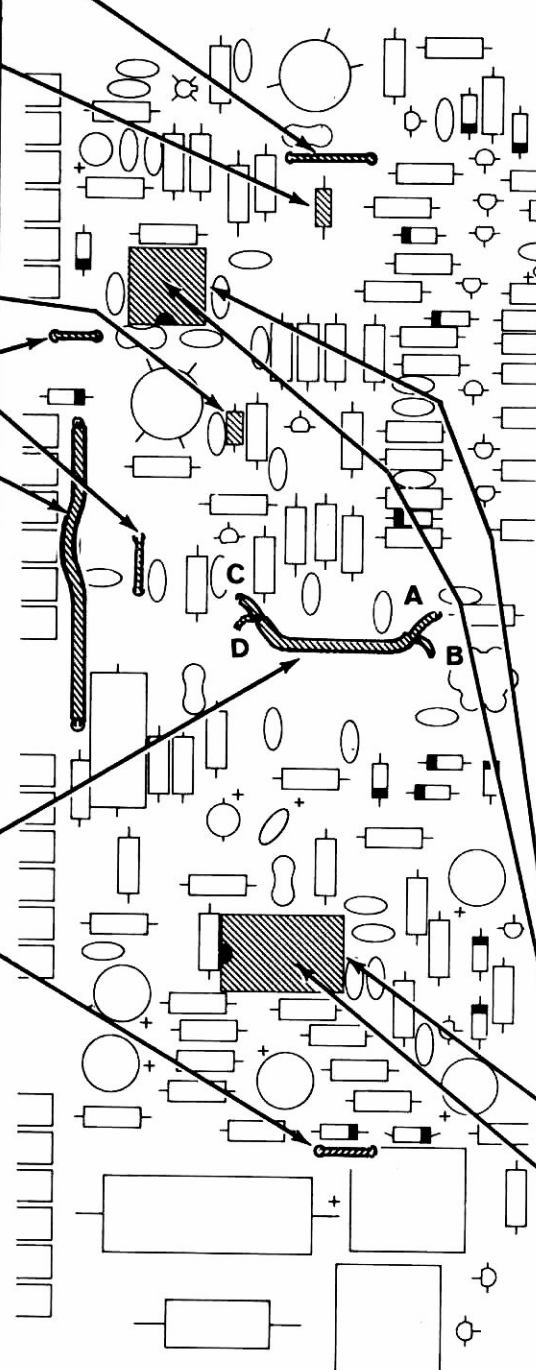

PICTORIAL 10-4

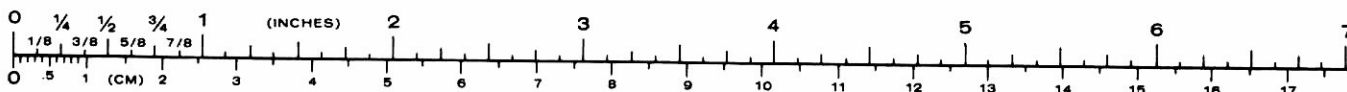

The steps performed in this Pictorial are in this area of the circuit board.

IDENTIFICATION DRAWING



PART NUMBER

START ↘

- Install eleven .01 μF disc capacitors at:
- () C503.
 - () C502.
 - () C517.
 - () C501.
 - () C508.
 - () C512.
 - () C511.
 - () C514.
 - () C515.
 - () C533.
 - () C519.

() Solder all leads to the foil and cut off the excess lead lengths.

() C542: .68 μF Mylar.

NOTE: Before you install an electrolytic capacitor, look at it and identify the leads. One lead will have a plus (+) mark or a minus (-) mark near it. **Be sure** to install the positive lead in the positive-marked hole. Be careful; only the negative lead may be marked.

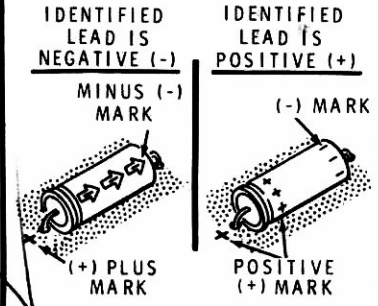

() C531: 500 μF electrolytic.

() Solder all leads to the foil and cut off the excess lead lengths.

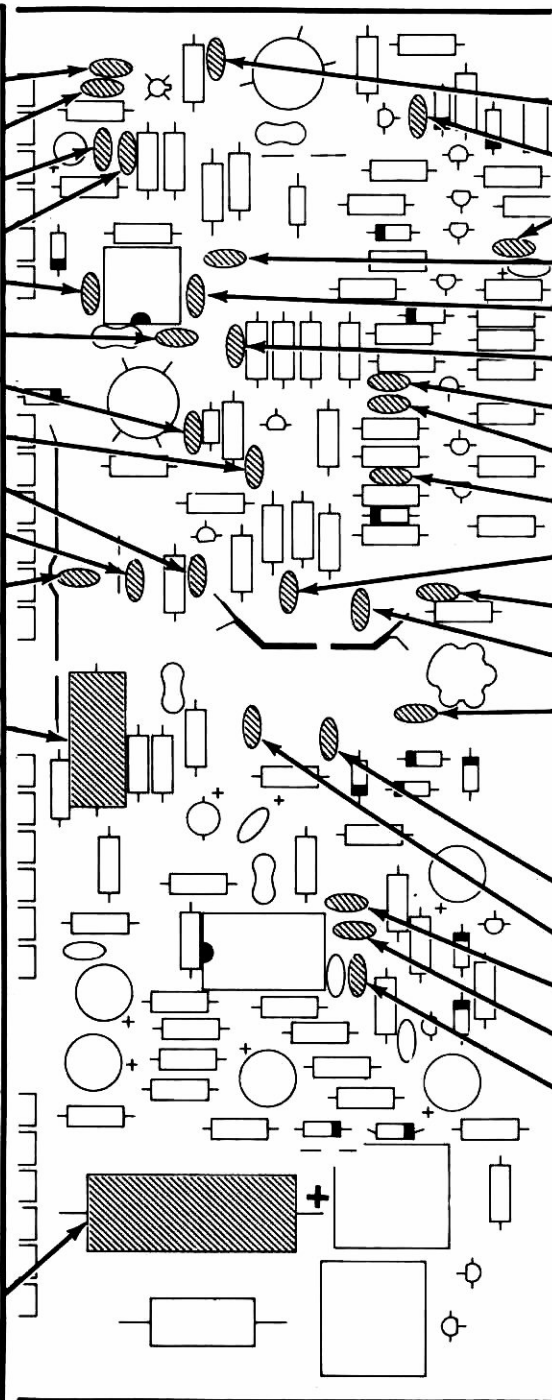

CONTINUE ↙

- Install thirteen .01 μF disc capacitors at:
- () C504.
 - () C532.
 - () C534.
 - () C507.
 - () C506.
 - () C513.
 - () C536.
 - () C538.
 - () C537.
 - () C516.
 - () C521.
 - () C539.
 - () C522.

() Solder all leads to the foil and cut off the excess lead lengths.

- Install five .001 μF disc capacitors at:
- () C523.
 - () C524.
 - () C551.
 - () C547.
 - () C546.

() Solder all leads to the foil and cut off the excess lead length.

PICTORIAL 10-5

The steps performed in this Pictorial are in this area of the circuit board.

START

NOTE: To install transistors in the following steps, match the transistor flat or tab to the outline printed on the circuit board and insert the leads into the holes. Position the transistor body 1/4" above the circuit board. Solder each lead to the foil and cut off the excess lead lengths.

() Bend the center (B) lead of seven MPSA20 transistors (#417-801) away from the flat as shown.



Install the seven transistors at:

- () Q512.
- () Q509.
- () Q508.
- () Q507.
- () Q502.
- () Q503.
- () Q504.

IDENTIFICATION DRAWING

PART NUMBER

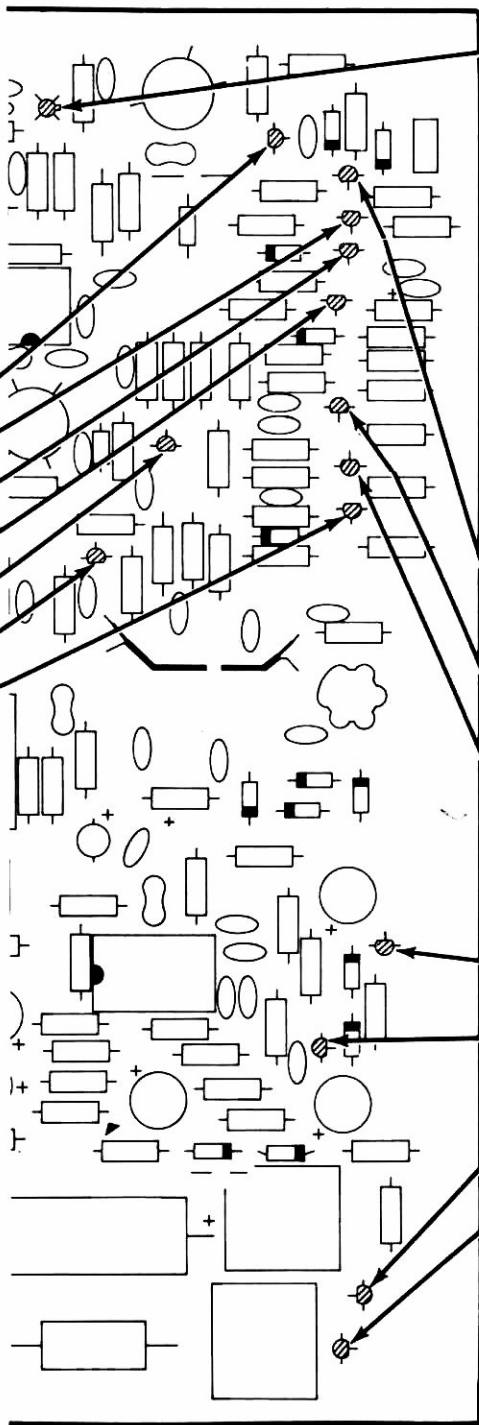

CONTINUE

() Q501: 40673 transistor (#417-274). First, line up the tab with the tab outline on the circuit board. Insert the transistor leads (identified in the detail) into the correct holes on the circuit board. Solder each lead to the foil and cut off the excess lead lengths. Then remove the shorting wire from the transistor leads.

SHORTING SPRING

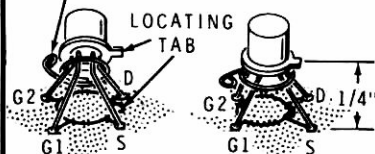

NOTE: Identify the leads of the following transistors from the appropriate detail. Then insert the leads into the indicated circuit board holes. Solder the leads to the foil and cut off the excess lead lengths.

BOTTOM VIEW OF TRANSISTOR

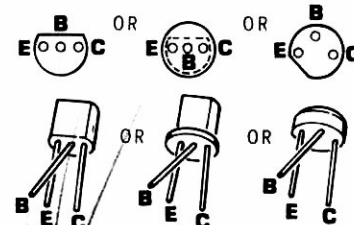

() Q511: 2N4121 transistor (#417-235).

() Q506: 2N4121 transistor (#417-235).

() Q505: MPSA20 transistor (#417-801).

() Q514: MPSA20 transistor (#417-801).

() Q513: 2N4121 transistor (#417-235).

() Q515: 2N3643 transistor (#417-233).

() Q517: 2N3638A transistor (#417-234).

PICTORIAL 10-6

The steps performed in this Pictorial are in this area of the circuit board.

IDENTIFICATION DRAWING

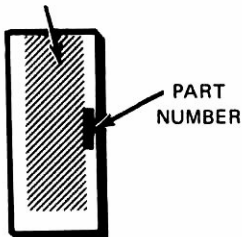

CONTINUE

NOTE: In the following step, do not be concerned if the coil has two lugs instead of three, as the coil can be installed either way.

() L501: Toroid coil (#40-1686). Solder the lugs to the foil.

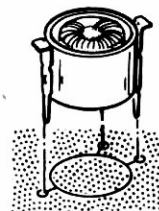

NOTE: Before you install an electrolytic capacitor, look at it and identify the leads. One lead will have a plus (+) mark or a minus (-) mark near it. Be sure to install the positive lead in the positive-marked hole. Be careful; only the negative lead may be marked.

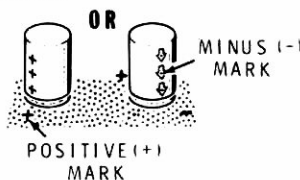

() C535: 2.2 μ F electrolytic.

Install two 10 μ F electrolytic capacitors at:

() C518.

() C549.

() C548: .68 μ F electrolytic.

Install five 100 μ F electrolytic capacitors at:

() C529.

() C527.

() C526.

() C541.

() C525.

() Solder all leads to the foil and cut off the excess lead lengths.

START

() C505: 160 pF mica.

() C509: 130 pF mica.

() T501: Toroid coil (#40-1687). Install this coil either way within the printed outline. Solder the lugs to the foil.

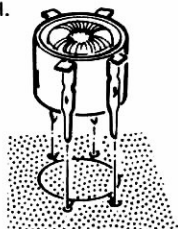

() T502: Toroid bifilar coil (#40-1688). Match the coil to the outline. Solder the lugs to the foil.



() C543: 820 pF mica.

() C544: 270 pF mica.

() C545: .1 μ F disc.

() C528: .05 μ F disc.

() C552: .05 μ F disc.

() Solder all leads to the foil and cut off the excess lead lengths.

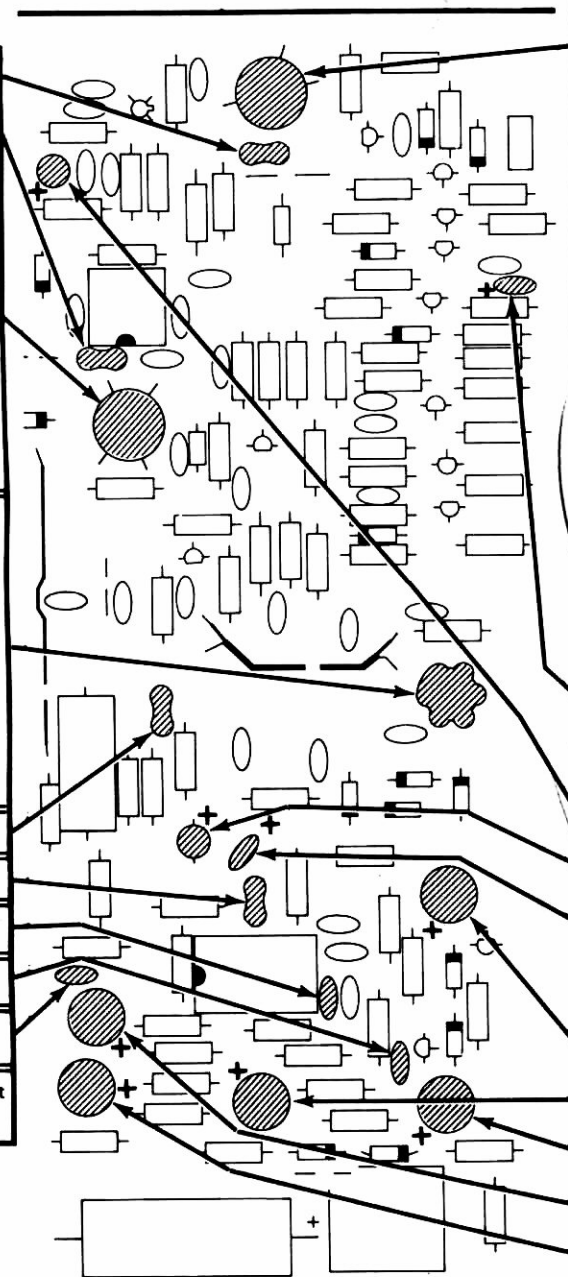

PICTORIAL 10-7

The steps performed in this Pictorial are in this area of the circuit board.

IDENTIFICATION DRAWING

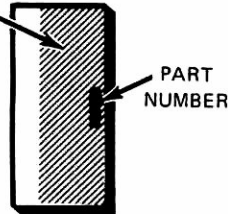

CONTINUE

START

(✓) R534: 5000 Ω control. (May be marked 5K). It may be necessary to move the 100 k Ω resistor slightly. Solder the lugs to the foil.

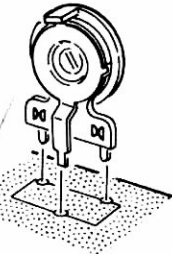

(✓) Cut a letter "F" from the label sheet. Carefully remove the protective backing paper from the letter and press this letter on the circuit board as shown.

() Q516: SJE607 transistor (#417-263). Position the metal side of the transistor against the heat sink and bend the leads down to provide at least 1/16" clearance from the heat sink. When you bend the transistor leads, hold the lead with thin-nose pliers between the bending point and the transistor body. Mount the transistor with 4-40 x 1/4" hardware. Solder the transistor leads and the heat sink tab to the foil.

4-40 x 1/4" SCREW

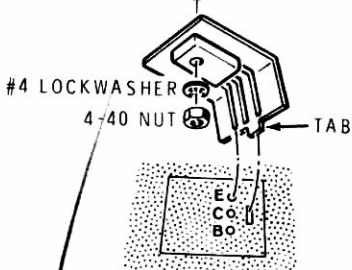

() Q518: SJE608 transistor (#417-264). Mount this transistor in a similar manner.

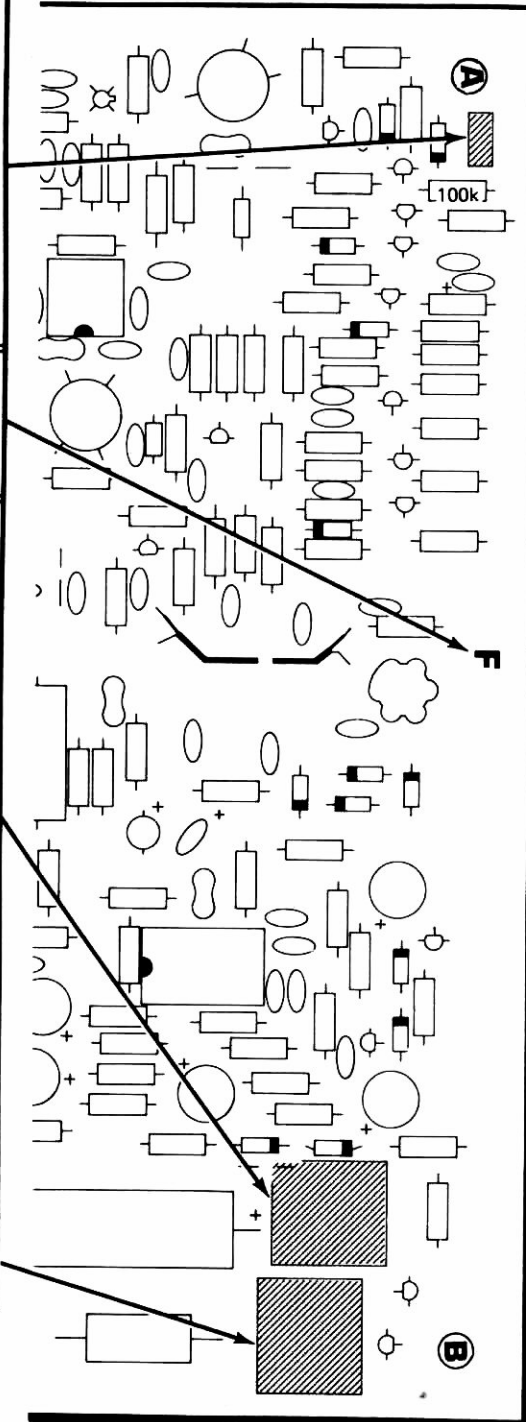

(✓) Mount board pullers on the foil side of the circuit board at holes A and B. Position the female part in the circuit board hole. Then push the male part through the female part.

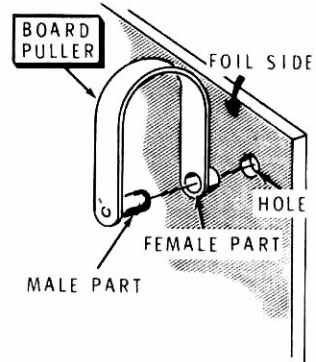

CIRCUIT BOARD CHECKOUT

Carefully inspect the circuit board for the following conditions.

- () Unsoldered connections.
- () "Cold" solder connections.
- () Solder bridges between foil patterns.
- () Protruding leads. No lead should be longer than 1/8".
- () Integrated circuits for the proper type and installation.
- () Electrolytic capacitors for the correct position of the positive (+) end.
- () Transistors for the proper type and installation.
- () Diodes for the correct position at the banded end.

Temporarily set the circuit board aside.

FINISH

PICTORIAL 10-8



POWER AMPLIFIER CIRCUIT BOARD

PARTS LIST

Remove the parts from Pack #9 and check each part against the following list. Make a check (✓) in the space provided as you identify each part. Any part that is packed in an individual envelope with the part number on it should be placed back in the envelope after you identify it until it is called for in a step. Do not throw away any packing materials until all parts are accounted for.

QTY.	DESCRIPTION	HEATH No.	CIRCUIT Component No.
RESISTORS			
() 5	10 Ω, 1/2-watt, (brown-black-black)	6-100	R951, R953, R955, R957, R958
() 1	100 Ω, 1/2-watt, (brown-black-brown)	6-101	R952
() 2	.15 Ω, 2-watt (brown- green-silver-gold)	3-14-2	R954, R956
() 1	100 Ω, 2-watt, 10% (brown-black-brown)	1-20-2	R959
CAPACITORS			
() 1	33 pF mica	20-160	C965
() 1	62 pF mica	20-109	C951
() 4	360 pF mica	20-131	C966, C967, C968, C969
() 2	.001 μF disc	21-140	C954, C959
() 7	.01 μF disc	21-176	C953, C955, C956, C958, C961, C962, C964
() 1	.1 μF disc	21-95	C952
() 2	25 μF electrolytic	25-145	C957, C963

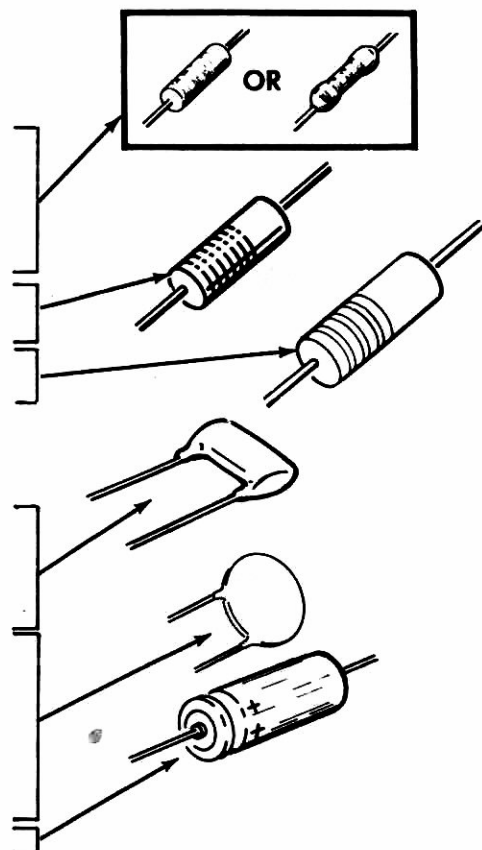

QTY.	DESCRIPTION	HEATH No.	CIRCUIT Component No.
MISCELLANEOUS			
() 1	2.2 μ H choke	45-73	RFC951
() 1	Fish paper	75-705	
() 4	8-32 nut	252-4	
() 4	10-32 nut	252-5	
() 1	Heat sink	205-1558	
() 4	Flat washer	253-25	
() 4	Short brass tube	266-827	
() 4	Long brass tube	266-828	
() 2	Clear tubing	346-26	
() 1*	Package, consisting of:	417-831-1	
4	2N6456 or CD-2664A transistor		Q951, Q952 Q953, Q954
() 6	Circuit board connector	432-124	
() 1	Phono socket	434-186	
() 3	5/16" ferrite bead	475-12	FB(3)
() 78	3/16" ferrite bead	475-17	L951, L952, L953, L954, L955, L956, L957, L958
() 1	Circuit board	85-1423	
() 1	Circuit board	85-1424	

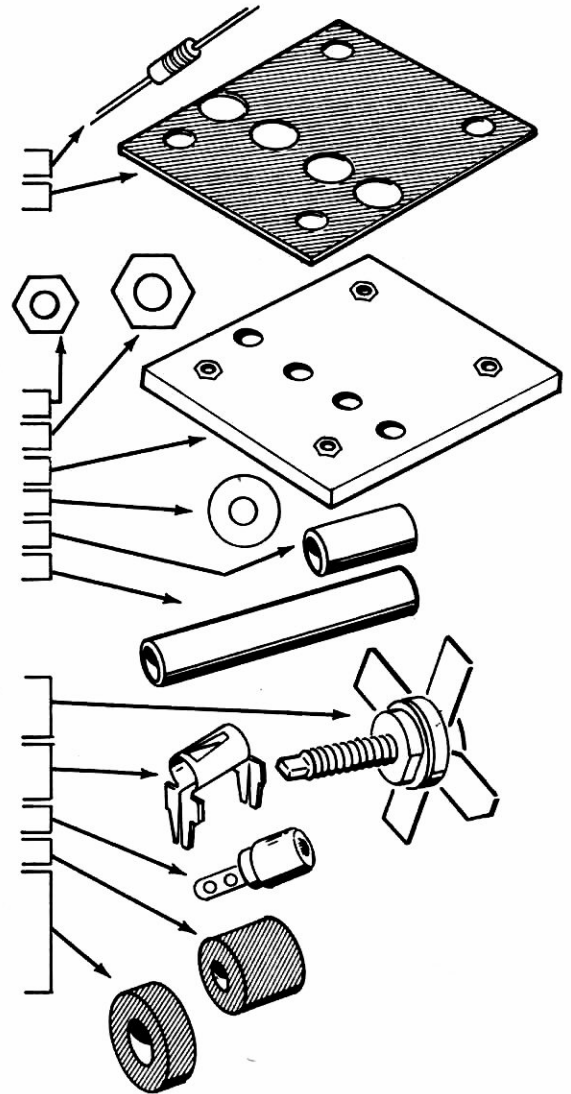

PART FROM PACK #10

() 1	Circuit board	85-2055-1
-------	---------------	-----------

*When ordering transistors, don't forget to order thermal compound, #352-31. See the chassis parts list.

To order a replacement part, always include the PART NUMBER. Use the Parts Order Form furnished with this kit. If one is not available, see "Replacement Parts" inside the rear cover of this Manual. Your Warranty is located inside the front cover. For pricing information, refer to the separate "Heath Parts Price List."

STEP-BY-STEP ASSEMBLY

START

Position the power amplifier circuit board (#85-2055-1) as shown. Then proceed with the following steps.

NOTE: When you install a ferrite bead in this Pictorial, the bead may move on the wire after it is installed. Use large bare wire.

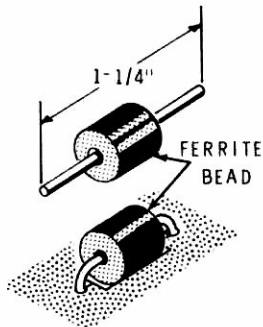

FOR GOOD SOLDER CONNECTIONS, YOU MUST KEEP THE SOLDERING IRON TIP CLEAN.

WIPE IT OFTEN WITH A DAMP SPONGE OR CLOTH.



PART NUMBER

- () 5/16" ferrite bead.
- () 5/16" ferrite bead.
- () 5/16" ferrite bead.
- () Solder the leads to the foil and cut off the excess lead lengths.

NOTE: Install the circuit board connectors in the following manner. Note that inside each connector the spring contact is depressed on one end. This depressed end of the connector must face away from the edge of the circuit board. Insert the mounting tabs through the circuit board until the ridges of the connector are firmly against the circuit board. Look at the row of connectors to make sure the depressed end of the contact of each connector is toward the center of the circuit board. Solder the tabs to the foil.

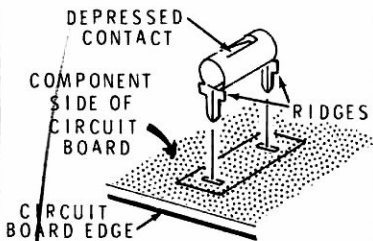

- () Six circuit board connectors.

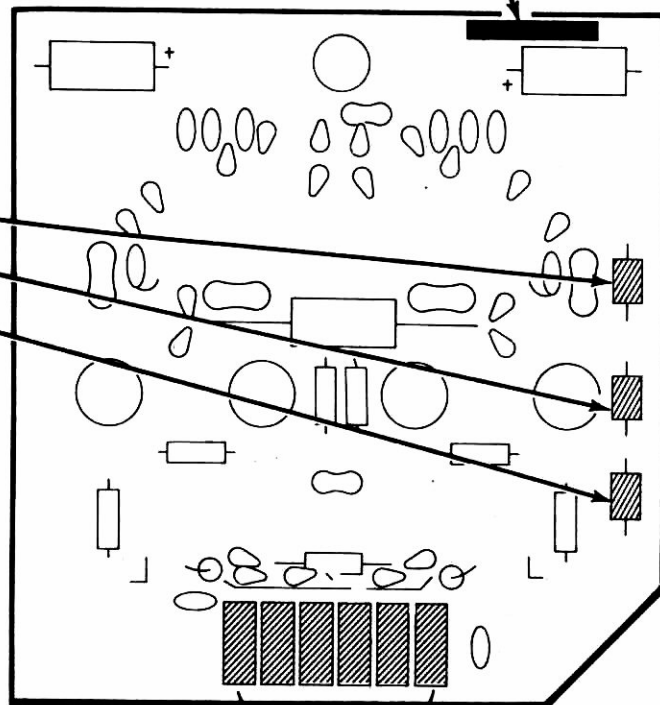

PICTORIAL 11-1

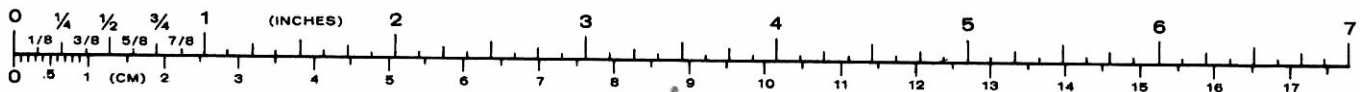

START

(1) Position the phono socket as shown, with the lug toward the foil pad shown in the following detail. Solder the outer shield to the circuit board foil. Then bend the inner lug over until its hole is aligned with the open hole in the foil. Be sure the inner lug does not touch the outer shield.

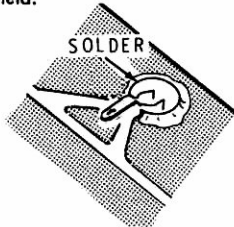

NOTE: Before you install an electrolytic capacitor, look at it and identify the leads. One lead will have a plus (+) mark or a minus (-) mark near it. Be sure to install the positive lead in the positive marked hole. Be careful; only the negative lead may be marked.

IDENTIFIED LEAD IS NEGATIVE (-)

MINUS (-) MARK



IDENTIFIED LEAD IS POSITIVE (+)

(-) MARK



(2) C963: 25 μ F electrolytic.

(3) C957: 25 μ F electrolytic.

(4) Solder the leads to the foil and cut off the excess lead lengths.

(5) R959: 100 Ω , 2-watt (brown-black-brown). NOTE: Bend the leads as shown to fit the circuit board outline.

(6) RFC951: 2.2 μ H choke (#45-73).

NOTE: Position the following resistor so holes R and S are not covered.

(7) R952: 100 Ω (brown-black-brown).

(8) 1-3/4" gray wire.

(9) Solder the leads to the foil and cut off the excess lead lengths.

PART NUMBER

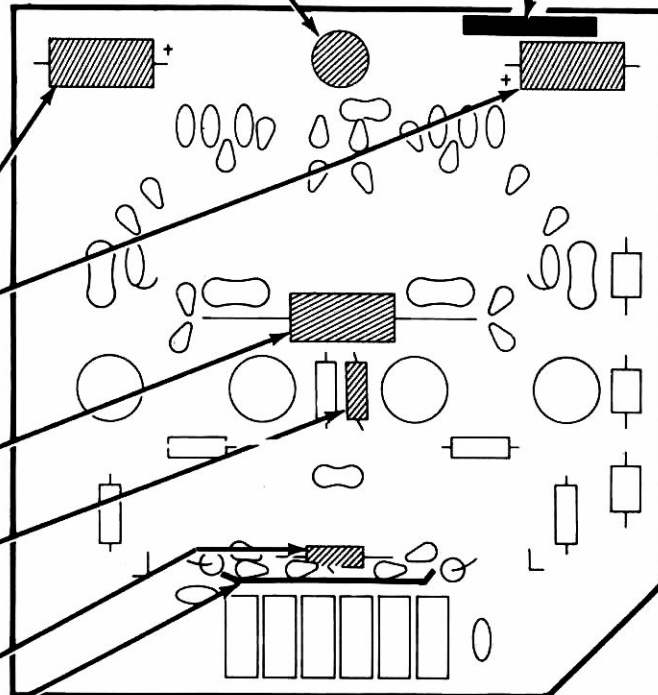

PICTORIAL 11-2

- START** →
- () C961: .01 μ F disc.
 - () C959: .001 μ F disc.
 - () C962: .01 μ F disc.
 - () C965: 33 pF mica. One lead passes through the foil and the hole in the phono socket lug. Solder both leads to the foil and one lead to the phono socket lug.
 - () C956: .01 μ F disc.
 - () C955: .01 μ F disc.
 - () C954: .001 μ F disc.
 - () Solder the leads to the foil and cut off the excess lead lengths.
 - () C951: 62 pF mica.
 - () C953: .01 μ F disc.
 - () C952: .1 μ F disc.
 - () Solder the leads to the foil and cut off the excess lead lengths.

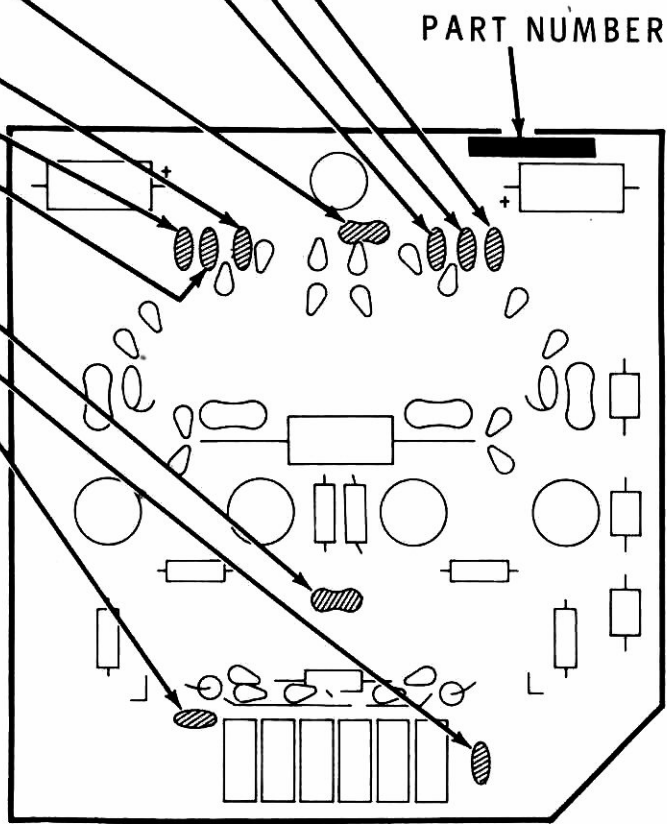

PICTORIAL 11-3

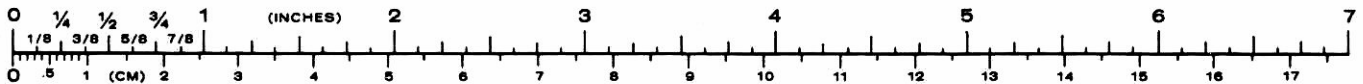

START

In the following steps, you will mount eight brass tubes on the circuit board. So they will take the solder easily, 1/4" of the end of each tube should be burnished with steel wool or fine sandpaper until it is bright. To mount the tubes, push them through the top of the board until they project approximately 1/32" through the foil side. Space the top of the tubes with the indicated small boards; then solder the tubes to the large circuit board foil. Solder around the circumference of each tube. Remove the small board from the top of the tubes temporarily.

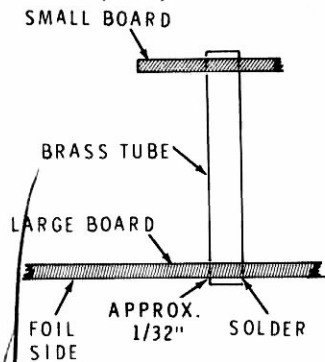

(1) Four long brass tubes. Use circuit board #85-1424 as a temporary spacer. Be sure the tubes are perpendicular to the circuit board. Solder the tubes to the foil.

(2) Four short brass tubes. Use circuit board #85-1423 as a temporary spacer. Be sure the tubes are perpendicular to the circuit board. Solder the tubes to the foil.

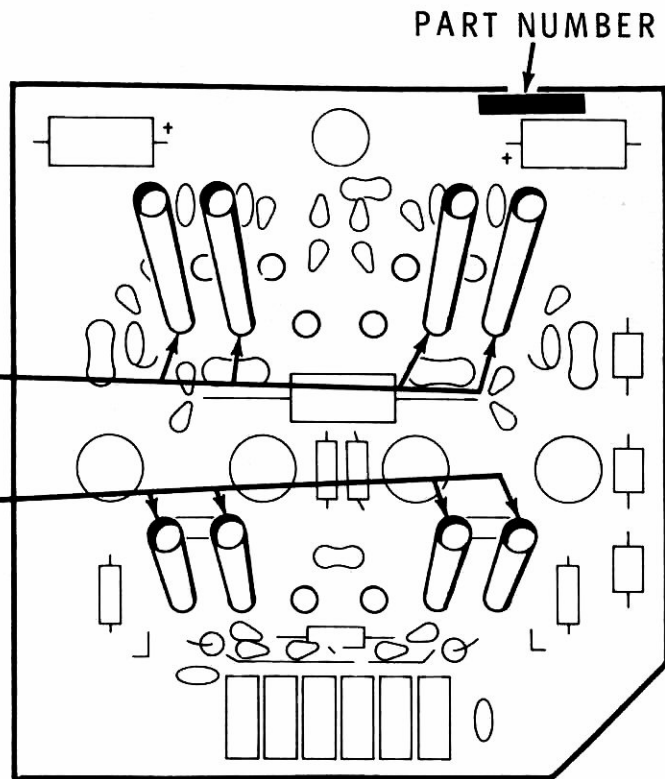

PICTORIAL 11-4

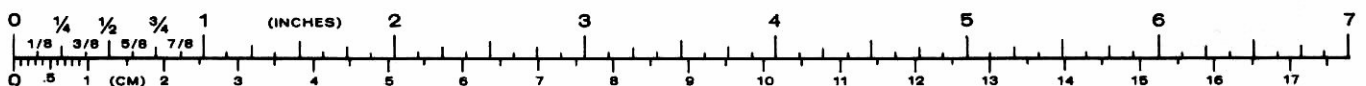

TRANSFORMER ASSEMBLY

Refer to Pictorial 11-5 (Illustration Booklet, Page 2) for the following steps.

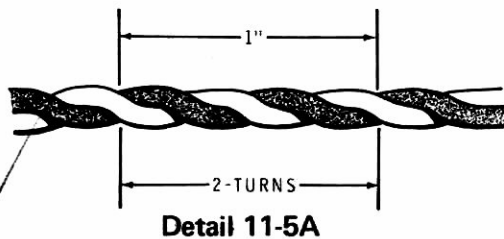

- (✓) Prepare a 20" red and a 20" gray wire. Twist these two wires together so there are approximately two complete turns for each inch of length as shown in Detail 11-5A. Cut this twisted pair into one 3", one 5-1/2", and two 4" lengths. Remove 1/4" of insulation from each wire end. Lay these pieces aside temporarily.

NOTE: When you cut pieces of clear tubing in the following steps, use a sharp knife or similar tool that will cut cleanly and cut the tubing squarely across. Try to cut each piece to exactly the specified length.

- () Cut two 1/2" lengths of clear tubing.
 () Cut six 1-1/8" lengths of clear tubing.

Refer to Detail 11-5B for the following four steps.

- () L952: Place three 3/16" ferrite beads over short brass tube LA, and another three beads over brass tube LB on the top of the circuit board.
 () L953: In the same manner, place three ferrite beads on tubes LE and LF.
 () Place three ferrite beads inside a 1/2" length of large tubing. Set this tube and beads in place at LC on the circuit board.
 () Place three more ferrite beads inside a 1/2" length of large tubing. Set this tube in place at LD on the circuit board. This step and the previous step complete the assembly of L951.

NOTE: As there are ferrite beads loosely mounted on the four brass tubes, and as some of them are placed loosely within clear tubing, do not jostle the circuit board or turn it upside down until these beads are secured in place in the following steps.

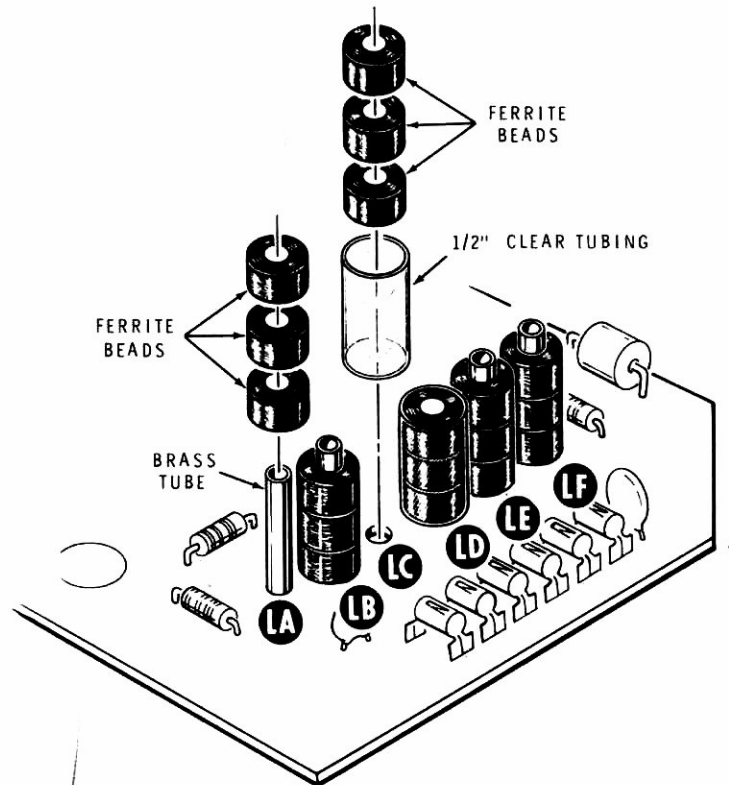

Detail 11-5B

- () Position the small circuit board (#85-1423) foil-side-up so the four brass tubes are centered in the four end holes of the board (two holes at each end of the board). Carefully work the board down over the tube ends. Push the board down onto the tops of the two lengths of clear tubing which contain ferrite beads. Make sure the two small holes are toward the connector edge of the power amplifier circuit board, as shown in the Pictorial.
 () Solder each of the four tube ends to the small circuit board foils. Solder completely around the circumference of each tube.
 () Pick up the 3" length of twisted wires (laid aside earlier), bend it into a narrow "U" shape, and push the two ends down through the stacks of ferrite beads at LC and LD. On the foil side of the circuit board, spread the wires apart, as when you mount resistors and capacitors. These wires hold the ferrite beads in place when you handle the power amplifier circuit board.

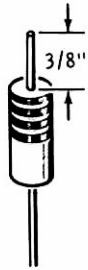

Detail 11-5C

() Refer to Detail 11-5C and prepare two .15 Ω, 2-watt resistors (brown-green-silver-gold) by cutting one lead of each resistor to 3/8".

R954, R956: Install each of the .15 Ω resistors in a vertical position at the locations marked A and B in the Pictorial. Insert the long leads into the circuit board. Solder the long leads to the circuit board foils and cut off the excess lead lengths.

() Bend the 3/8" lead of each resistor so it touches an end foil of the small circuit board (#85-1423). Then solder the bent leads to the two foil pads. Ignore the remaining hole in each foil.

() L954: Refer to Detail 11-5D and place six ferrite beads on each brass tube, LG and LH.

() L955: Place six ferrite beads on each brass tube, LL and LM.

() Place six ferrite beads into each of the six 1-1/8" pieces of clear tubing to form six beads assemblies.

NOTE: Carefully position the bead assemblies on the top of the circuit board in the following steps. A piece of plastic tape might be helpful to hold them in place until they are wired in position later.

() L958: Place bead assemblies at LJ and LK.

() L956: Place bead assemblies at LN and LP.

() L957: Place bead assemblies at LR and LS.

() Position the small circuit board (#85-1424) foil-side-up. Then carefully work it down over the ends of the four brass tubes. Push the board down against the tops of the six bead assemblies.

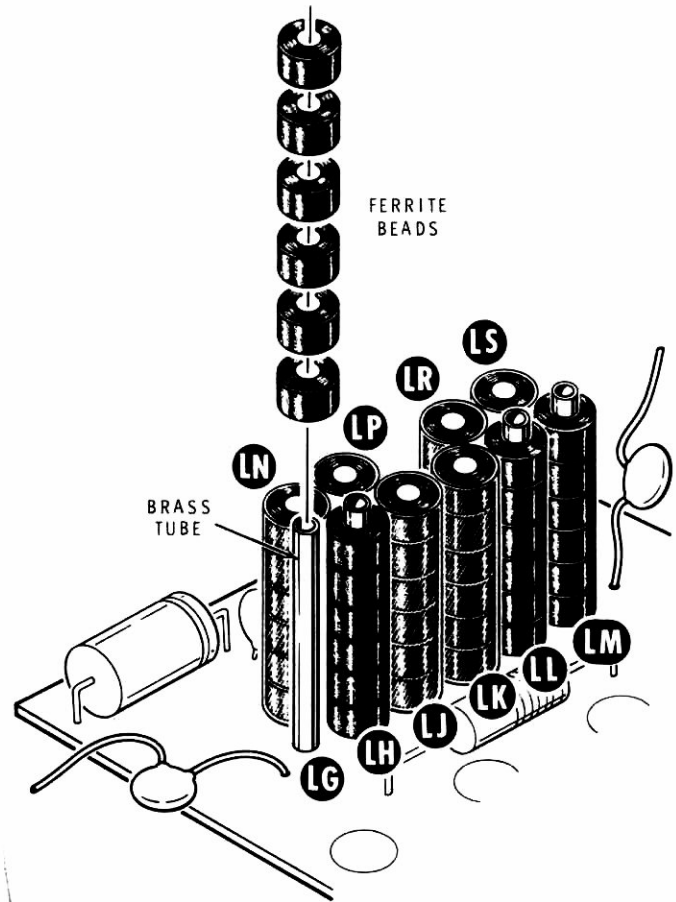

Detail 11-5D

() Solder the four brass tubes to the circuit board foils. Solder completely around the circumference of each tube.

() Refer to Detail 11-5E, bend the 5-1/2" pair of twisted wires into a "U" shape, and push the ends down through the ferrite bead stacks at LJ and LK. Spread the wires apart on the foil side of the circuit board to hold the wires (and beads) in place.

() Similarly, use a 4" twisted pair of wires at LN and LP.

() Use a 4" twisted pair of wires at LR and LS.

() C958 and C964: Install two .01 μF disc capacitors between the large and small circuit boards as shown. Solder the four leads to the circuit board foils and cut off the excess lead lengths.

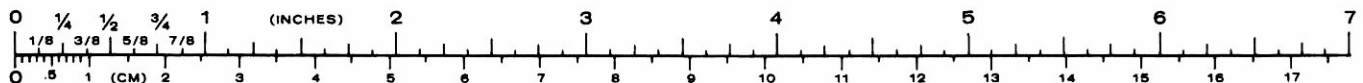

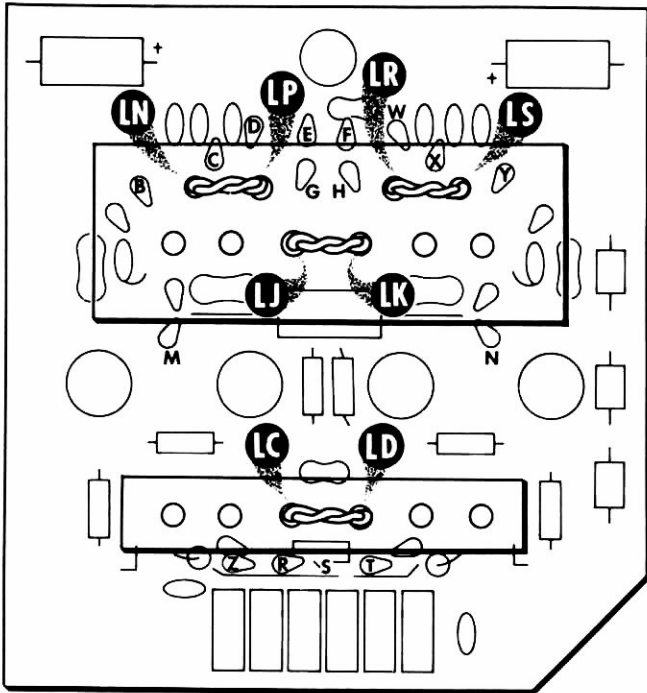

Detail 11-5E

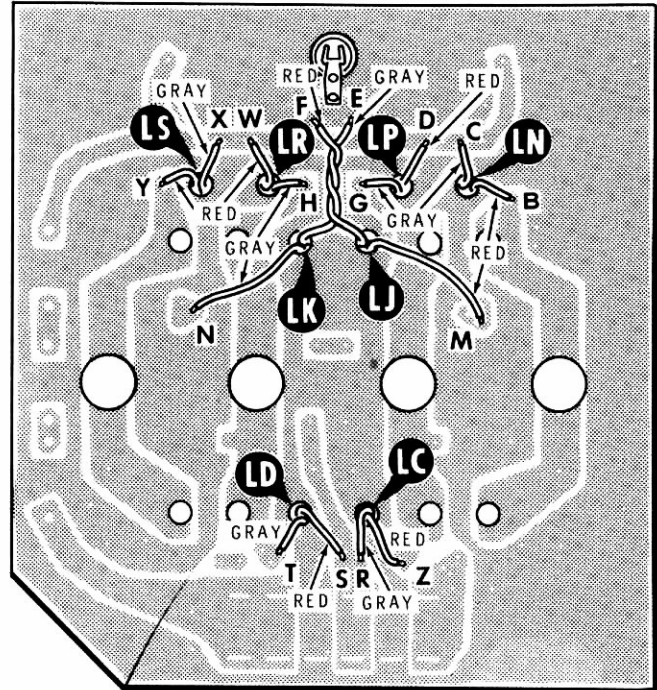

PICTORIAL 11-6

Refer to Pictorial 11-6 for the following steps.

NOTE:

- In the following steps, circuit board holes are identified on the component side of the board. When you connect a wire in these steps, push the wire end into the hole from the foil side and solder the wire to the foil. Then cut any excess wire ends from the top of the board. Trim the wires to length, if necessary.
- Each wire to be soldered in this Pictorial is bent over the sharp edge of a circuit board hole. Before you solder each lead, be sure there is a small amount of clearance between the wire insulation and the edge of the hole so the soldering heat will not soften the insulation and possibly cause a short circuit.

- () Connect the red wire coming from LC to hole Z (S-1).
- () Connect the gray wire coming from LC to hole R (S-1).
- () Connect the red wire coming from LD to hole S (S-1).

- () Connect the gray wire coming from LD to hole T (S-1).
- () Connect the red wire coming from LJ to hole M (S-1).
- () Connect the gray wire coming from LK to hole N (S-1).
- () Twist the remaining two wires coming from LK and LJ together. Connect the red wire to F (S-1) and the gray wire to E (S-1).
- () Refer to the Pictorial and connect the gray wire coming from LN to hole C (S-1) and the red wire to hole B (S-1).
- () Connect the gray wire coming from LP to hole G (S-1) and the red wire to hole D (S-1).
- () Connect the gray wire coming from LR to hole H (S-1) and the red wire to hole W (S-1).
- () Connect the gray wire coming from LS to hole X (S-1) and the red wire to hole Y (S-1).

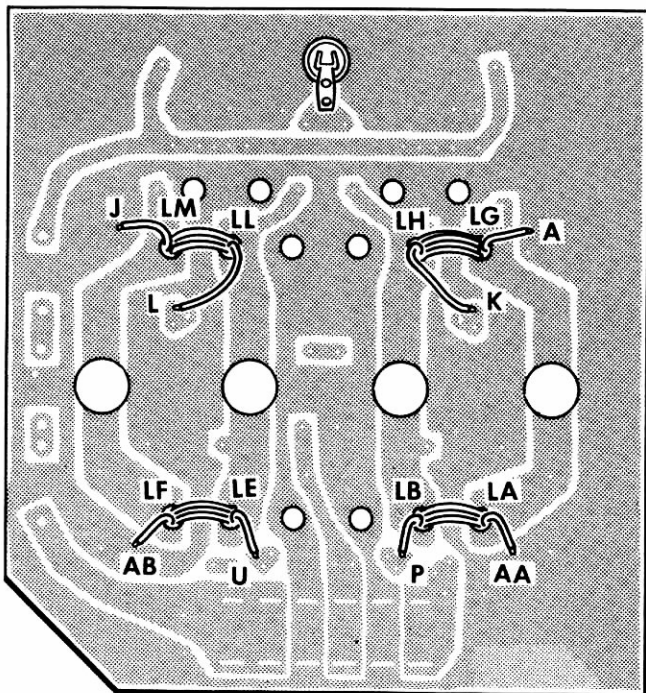

PICTORIAL 11-7

Refer to Pictorial 11-7 for the following steps.

IMPORTANT: In the following steps you will be instructed to form coils with stranded white wire and to install four power transistors. This is a critical phase in the construction. Failure in this area can result in a Tranceiver which does not operate and in costly replacement of the power transistors. The construction steps are not difficult but they must be followed carefully. (The Heath warranty does not cover incorrect assembly.)

Refer to Pictorial 11-7 for the following steps.

NOTES:

1. You will "prepare" a wire by removing 1/4" of insulation from each end. The Teflon insulation used on this wire is very tough and you may find it difficult to remove. Use a very sharp knife but be careful not to nick the fine strands of wire underneath.

2. So there is no chance of creating a short circuit:
 - A. Let the insulation on a wire extend at least to the edge of the foil pad to which the wire is soldered.
 - B. Do not pull the wire tightly against the edge of a brass tube; this eventually might cut through the insulation.
 - C. Inspect the bare ends of each wire very carefully for stray strands of fine wire which could touch some other wire or foil pad.

Prepare the following lengths of stranded white wire:

- 9-3/4" 19"
- 9-3/4" 19"

3. Connect one end of a 9-3/4" stranded white wire to hole AB (S-1). Pass the free end of this wire upward through tube LF. From the top of the board, pass the end of the wire down through tube LE; then again upward through LF. Continue in this manner until there are four complete turns of wire across the top of transformer L952. Connect the end of the wire coming from tube LE to hole U (S-1). Adjust the wire turns to take up any excess wire length.
4. Connect one end of a 9-3/4" stranded white wire to hole AA (S-1). In the same manner as in the last step, wrap four complete turns of wire through tubes LA and LB. Connect the end of the wire to hole P (S-1).
5. Connect one end of a 19" stranded white wire to hole J (S-1). Wrap five complete turns of wire through tubes LM and LL. Connect the end of the wire to hole L (S-1).
6. Connect one end of a 19" stranded white wire to hole A (S-1). Wrap five complete turns of wire through tubes LG and LH. Connect the end of the wire to hole K (S-1).

IMPORTANT: In the following steps you will install four power transistors on the circuit board. It is very important that the entire surface of each of the four leads is flat against the surface of the board. Use a screwdriver, for example, to hold the lead flat against the board until the solder cools.

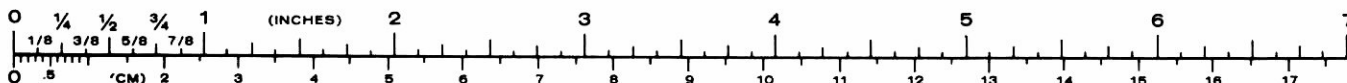

TRANSISTOR INSTALLATION

START

IMPORTANT: If the power transistors furnished (#417-831) are type CTC CD-2664A, install them as shown in this Pictorial. If the transistors furnished are type 2N6456, proceed to Pictorial 11-9 and disregard this Pictorial.

Study the following steps carefully and have in mind just what is to be done and how you will do it. Only then should you perform the steps.

- () Turn the circuit board foil-side-up so the board part number is in the position shown.

NOTES:

1. Handle power transistors with care, particularly the studs.
2. Before you solder transistor leads:
 - A. Make sure the white body is centered in its circuit board hole.
 - B. Make sure the base lead does not cover the holes indicated in the Pictorial. Trim the base lead as necessary to clear the hole.
 - C. Push the leads against the circuit board foil. When soldering, run the solder along the edges of the leads as close as possible to the transistor body. It may help to press the lead against the circuit board foil with a screwdriver blade until the solder hardens.
3. When you are instructed to tighten a nut "finger tight," it means to tighten that nut with your fingers as much as possible. It does not mean to leave the nut loose, nor does it mean to use a wrench.

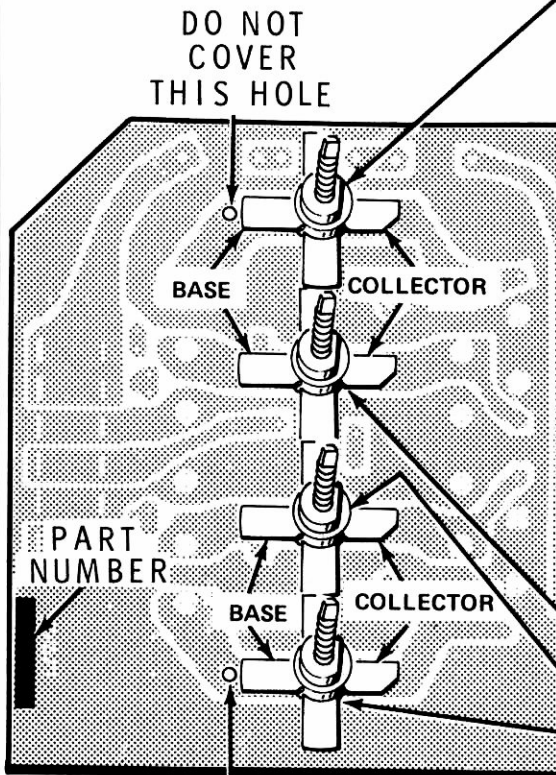

CONTINUE

- () Q954: From the foil side of the circuit board, place the round, white, top portion of a CTC CD-2664A transistor into the hole shown. Position the lead with the cutoff corner so it points in the same direction as the letter C on the top of the board. Form the leads down against the foil for as much of their length as possible. Make sure each transistor stud is perpendicular to the circuit board. Then solder each lead to the foil. Carry the solder up as close as possible to the transistor body to reduce the effective length of the leads.

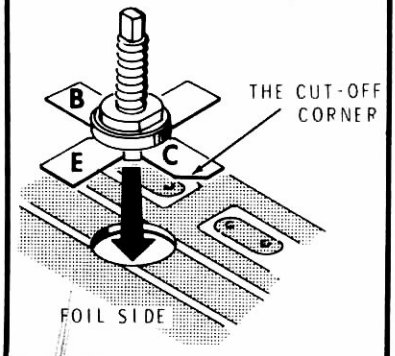

- () Q953: CTC CD-2664A transistor.
- () Q952: CTC CD-2664A transistor.
- () Q951: CTC CD-2664A transistor.

Proceed to Pictorial 11-10 on Page 1-131.

DO NOT COVER THIS HOLE

PICTORIAL 11-8

START

IMPORTANT: Follow this Pictorial ONLY if you were furnished type 2N6456 transistors (#417-831).

Study the following steps carefully and have in mind just what is to be done and how you will do it. Only then should you perform the steps.

NOTES:

1. Handle power transistors with care, particularly the studs.
2. Before you solder transistor leads:
 - A. Make sure the white body is centered in its circuit board hole.
 - B. Push the leads against the circuit board foil. When soldering, run the solder along the edges of the leads as close as possible to the transistor body. It may help to press the lead against the circuit board foil with a screwdriver blade until the solder hardens.
3. When you are instructed to tighten a nut "finger tight," it means to tighten that nut with your fingers as much as possible. It does not mean to leave the nut loose, nor does it mean to use a wrench.

() Cut a 1" piece of 3/8" clear tubing.

() Carefully stretch one end of the plastic tubing over the top of a transistor.

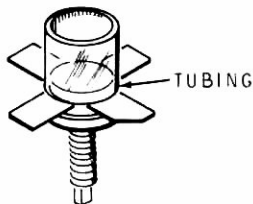

CONTINUE

() Turn the circuit board foil-side-up so the part number is in the position shown.

() Q951: From the foil side of the circuit board, push the tubing and then the transistor into the hole shown. Position the lead with the cutoff corner so it points to the letter C on the top of the board. Form the leads down against the foil for as much of their length as possible. Make sure each transistor stud is perpendicular to the circuit board. Then solder each lead to the foil. Carry the solder up as close as possible to the transistor body to reduce the effective length of the leads.

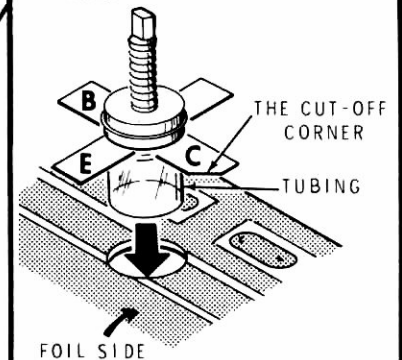

() Remove the tubing for use with the remaining three transistors.

NOTE: Install the following transistors as before.

() Q953: 2N6456 transistor.

() Q952: 2N6456 transistor.

() Q951: 2N6456 transistor.

Proceed to Pictorial 11-10.

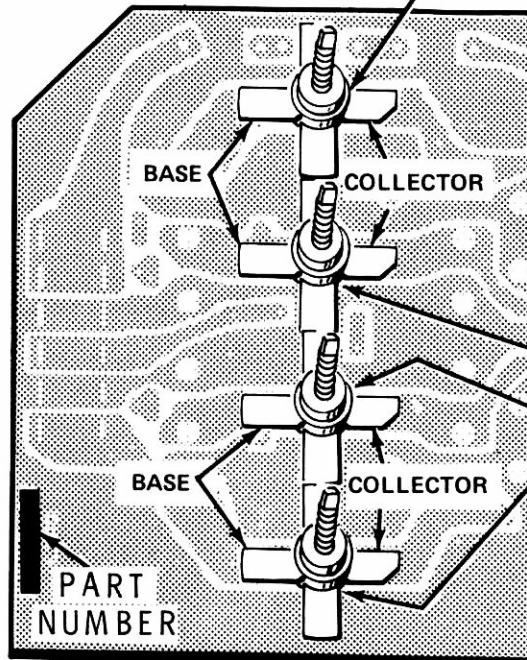

PICTORIAL 11-9

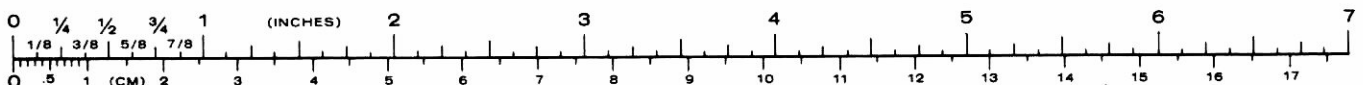

START

() Four 360 pF mica capacitors.

C969.

C968.

C966.

C967.

() Five 10 Ω (brown-black-black) resistors.

R951.

R955.

R953.

R957.

R958.

() Solder the leads to the foil and cut off the excess lead lengths.

CIRCUIT BOARD CHECKOUT

Carefully inspect the circuit board for the following conditions.

- () Unsoldered connections.
- () "Cold" solder connections.
- () Solder bridges between foil patterns.
- () Protruding leads. No lead should be more than 1/8".
- () Transistors for the proper type and installation.
- () Electrolytic capacitors for the correct position of the positive (+) end.

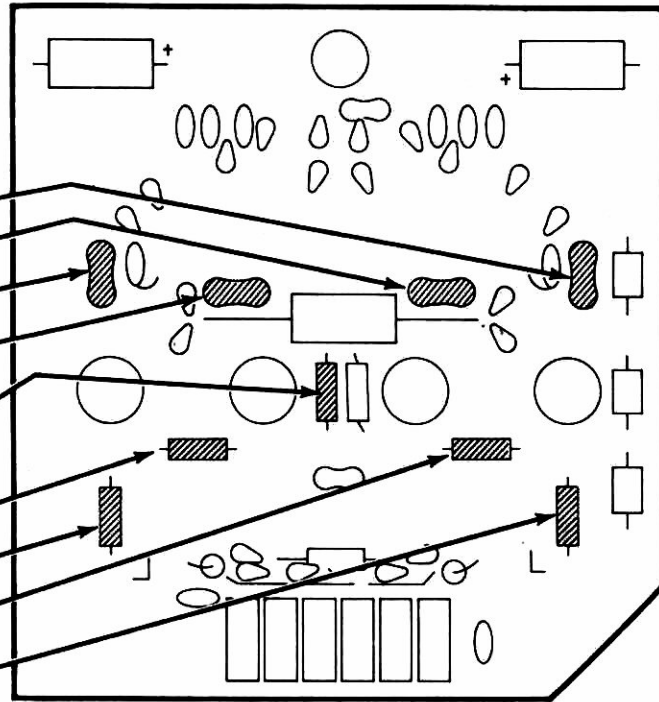

PICTORIAL 11-10

Refer to Pictorial 11-11 (Illustration Booklet, Page 2) for the following steps.

WARNING: You will be using Dow Corning 340 thermal heat sink compound in the next step and in several other steps in the Manual. Although the compound is not caustic, it may cause temporary discomfort if it gets into your eyes. Should this happen, rinse your eyes with warm water. If the compound gets into your clothing, the clothing may require professional cleaning. The compound contains Zinc Oxides, SiO₂, and slight traces of CO₂.

- () Place an even amount of thermal compound on the shoulders of the four power transistors as shown in the Pictorial.

NOTE: Perform the following step **ONLY** if you have 2N6456 power transistors.

- () Place the four flat washers over the transistor studs. Then liberally coat these washers with thermal compound.

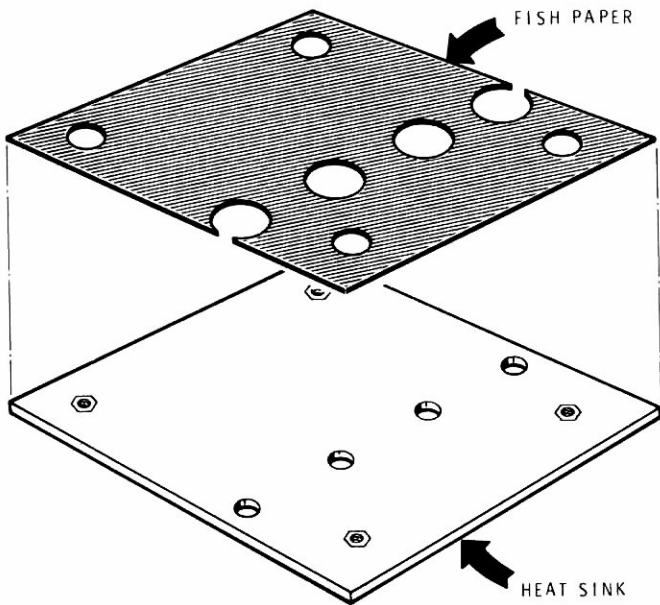

Detail 11-11A

Refer to Detail 11-11A and remove the protective covering from the fish paper. Center the fish paper holes over the heat sink holes and press the adhesive side of the fish paper onto the back of the heat sink as shown. Be sure the hexagonal part of each of the four captive nuts is toward the fish paper.

NOTE: When you mount the heat sink on the transistor studs in the following steps, position the gray fish paper side of the heat sink toward the circuit board foil.

- () Place the heat sink onto the four transistor studs as shown. Use the nuts provided with the transistors. If no nuts were packed with the transistors, use 8-32 nuts with 2N6456 transistors, or 10-32 nuts with CD-2664A transistors. Turn the nuts as tightly as you can with your fingers **ONLY**.
- () Sight between the heat sink and the circuit board to make sure there are no long leads which can touch the back of the heat sink and cause a short circuit. Remove the heat sink and trim any long leads.

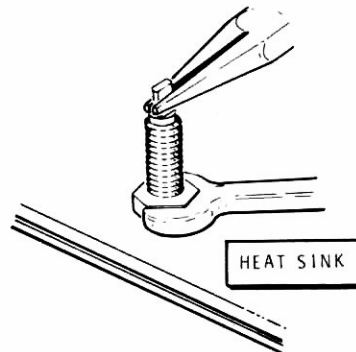

Detail 11-11B

- () Refer to Detail 11-11B and hold the wrench flats on the end of the transistor stud with pliers to keep the transistor stud from turning. Then tighten each mounting nut 1/8 turn more with a wrench.

NOTE: Depending upon which transistors you were furnished (and how they were packaged) you may have #8-32 and/or #10-32 nuts and four flat washers remaining.

This completes the step-by-step assembly of your power amplifier circuit board. Set it aside temporarily.

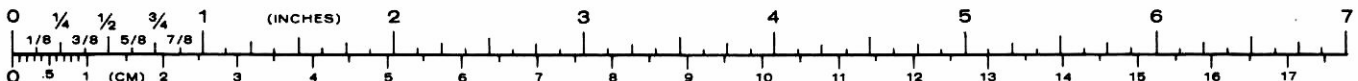

CHASSIS ASSEMBLY

PARTS LIST

Check each of the remaining parts against the following list. Make a check (✓) in the space provided as you identify each part. Any part that is packed in an individual envelope with

the part number on it should be placed back in the envelope after you identify it until it is called for in a step. Do not throw away any packing materials until all parts are accounted for.

QTY.	DESCRIPTION	HEATH No.	CIRCUIT Component No.
RESISTORS-CONTROLS			
() 1	.15 Ω 2-watt (brown-green-silver-gold)	3-14-2	R5
() 1	.33 Ω 2-watt (orange-orange-silver-gold)	3-2-2	R6
() 1	15 Ω, 1-watt, 10% (brown-green-black-silver)	1-12-1	R11
() 1	22 Ω, 1/2-watt (red-red-black)	6-220	R18
() 1	47 Ω, 1/2-watt (yellow-violet-black)	6-470	R19
() 1	150 Ω 1/2-watt (brown-green-brown)	6-151	R21
() 1	180 Ω 1/4-watt (brown-gray-brown)	6-181-12	R13
() 2	5600 Ω, 1/2-watt (green-blue-red)	6-562	R16, R17
() 1	16 kΩ 1/2-watt (brown-blue-orange)	6-163	R12
() 1	22 kΩ, 1/2-watt (red-red-orange)	6-223	RF DET.
() 2	10 kΩ, .12-watt control	10-88	R7, R8
() 1	10 kΩ, .5-watt control	10-31	R9
() 2	100 kΩ, .3-watt control	10-995	R1, R3
() 1	10 kΩ/6 kΩ dual control	12-113	R15
() 1	200 kΩ/1500 Ω dual control	12-138	R2
() 1	16 Ω, 5%, 24-watt	3-3-24	R14

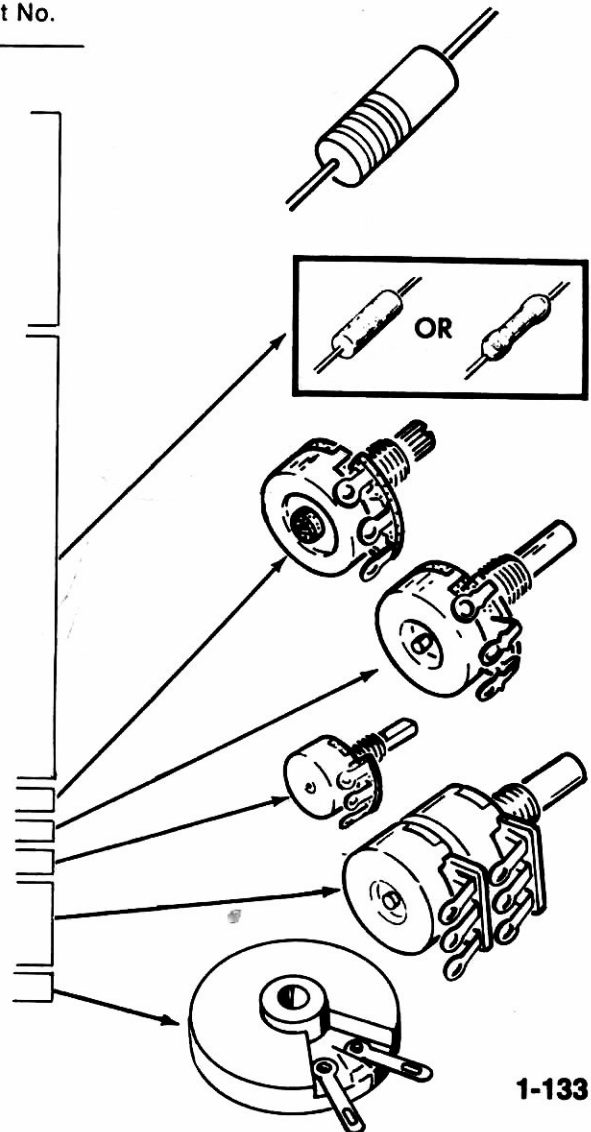

QTY.	DESCRIPTION	HEATH No.	CIRCUIT Component No.	
CAPACITORS				
()	1	18 pF disc	21-60	Test
()	2	.001 μ F disc	21-140	C13, C15
()	5	.01 μ F disc	21-176	C5, C17, C18, C22, RF Det.
()	1	47 μ F electrolytic	25-915	C2
()	1	5 μ F electrolytic	25-149	C14
()	1	10 μ F electrolytic	25-54	C1
()	1	50 μ F electrolytic	25-98	C3
()	1	500 μ F electrolytic	25-157	C12
()	1	1000 μ F electrolytic	25-219	C6
()	1	62 pF mica	20-109	Carrier Null
()	5	.1 μ F Mylar	27-47	C4, C16, C19, C21, C23

DIODES-TRANSISTORS

()	1	1N3491 diode	57-34	D1
()	3	1N191 diode (brown-white-brown)	56-26	D5, D6, RF Det.
()	1	Zener diode 9.1 V, 25 mA	56-19	ZD1
()	1	GD510 diode	56-89	D7
()	3	1N4149 diode	56-56	D2, D3, D4
()	2	MHT9210 transistor	417-162	Q1, Q2

SWITCHES-RELAY

()	1	DPDT slide	60-2	S5
()	1	2-wafer rotary	63-721	S1
()	1	Single wafer rotary	63-722	S4
()	1	Pushbutton	64-673	S3
()	1	Pushbutton	64-674	S2

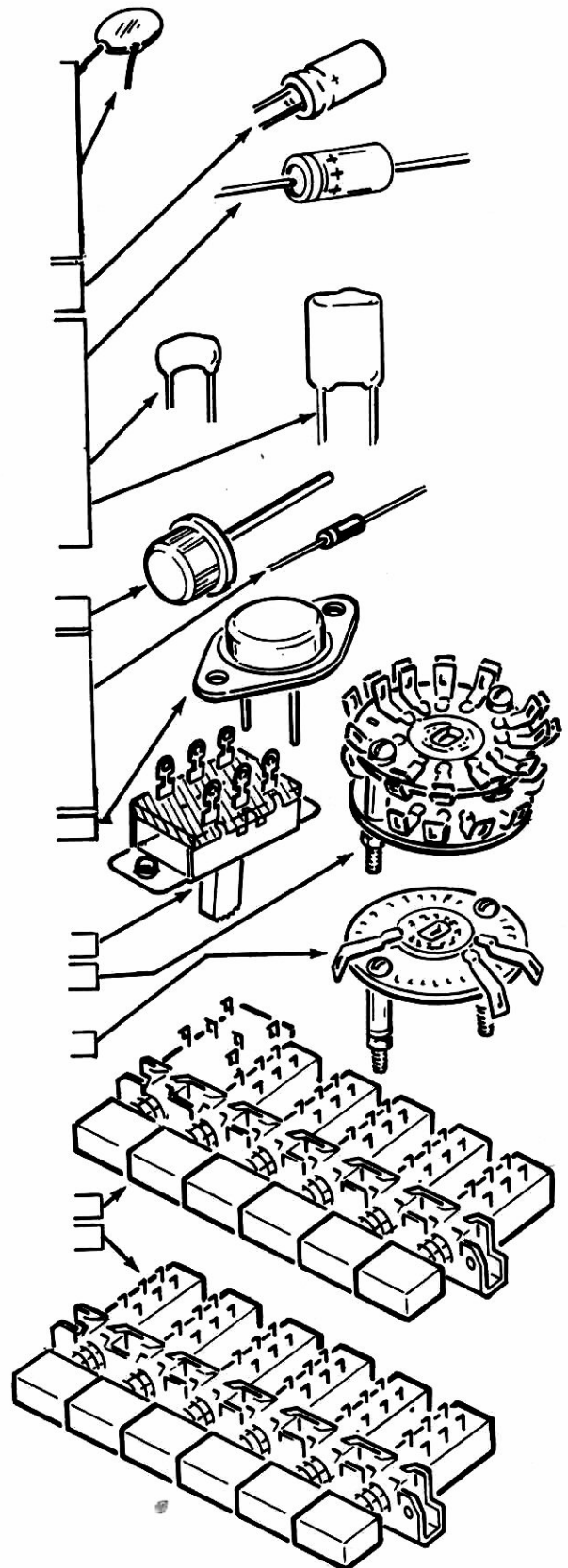

QTY.	DESCRIPTION	HEATH No.	CIRCUIT Component No.
------	-------------	-----------	-----------------------

SWITCHES-RELAY (cont'd.)

()	1	Relay	69-72	Ry
()	1	3-position detent	266-1114	
()	1	9-position detent	266-1117	

INSULATORS

()	4	Large plastic grommet	73-45
()	1	Small plastic grommet	73-52
()	2	Transistor socket insulator	75-44
()	2	Fish paper	75-108

SHEET METAL PARTS

()	1	Top cabinet shell	90-1106-4
-----	---	-------------------	-----------

()	1	Bottom cabinet shell	90-1107-4
-----	---	----------------------	-----------

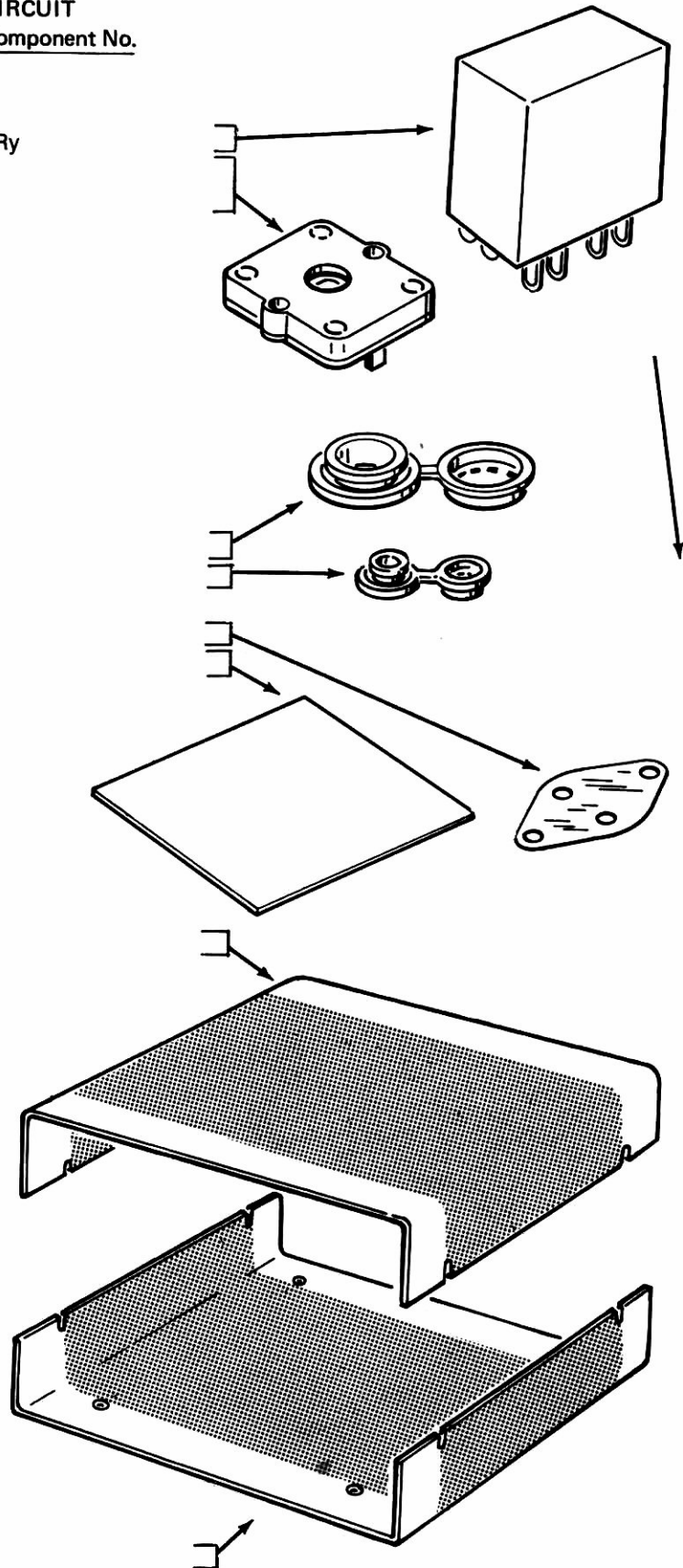

QTY.	DESCRIPTION	HEATH No.	CIRCUIT Component No.
------	-------------	-----------	-----------------------

SHEET METAL PARTS (cont'd.)

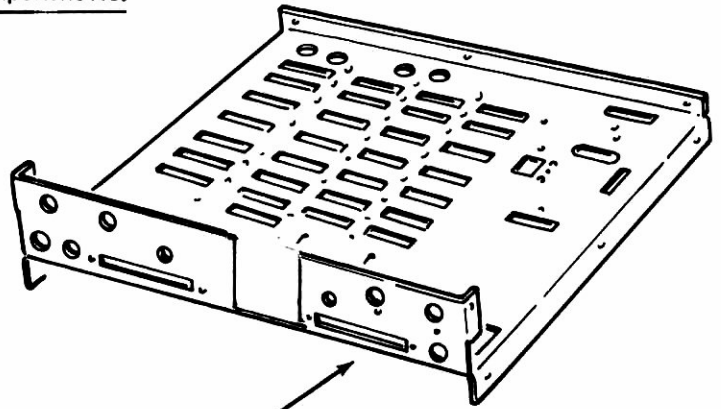

()	1	Chassis	200-1232
()	1	Front panel	203-1532-2

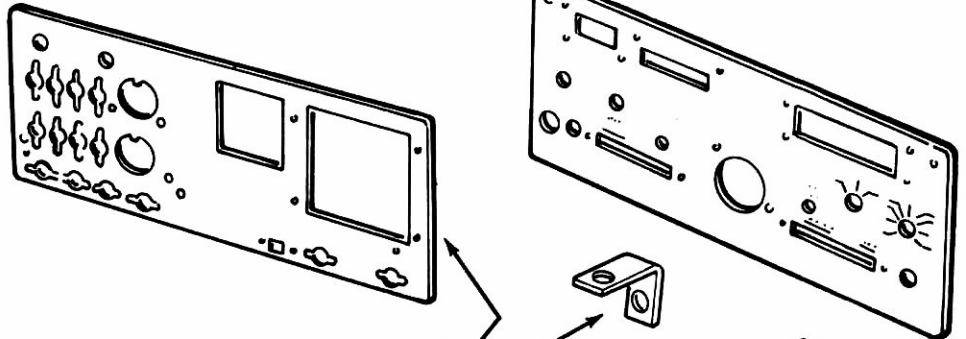

()	1	Rear panel	203-1596-3
()	2	Panel bracket	204-102
()	2	Window bracket	204-1918

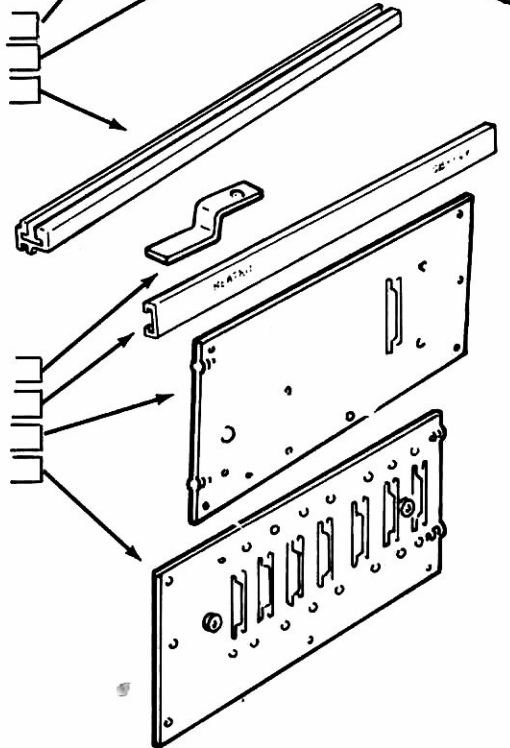

()	2	Meter bracket	204-2003
()	1	Panel trim strip	205-1432-4
()	1	Right side panel	205-1555
()	1	Left side panel	205-1556

QTY.	DESCRIPTION	HEATH No.	CIRCUIT Component No.
SHEET METAL PARTS (cont'd.)			
() 1	Diode retainer plate	205-1557	
() 2	Cabinet retainer strip	205-1576	
() 2	Call letter clip	205-1585	
() 7	Circuit board shield	206-1101	

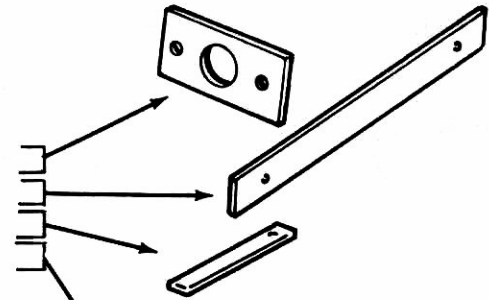

() 1	PA shield (7 clips one side, 1 clip other side)	206-1102
() 1	Lateral shield	206-1103
() 1	ALC/output filter shield	206-1265

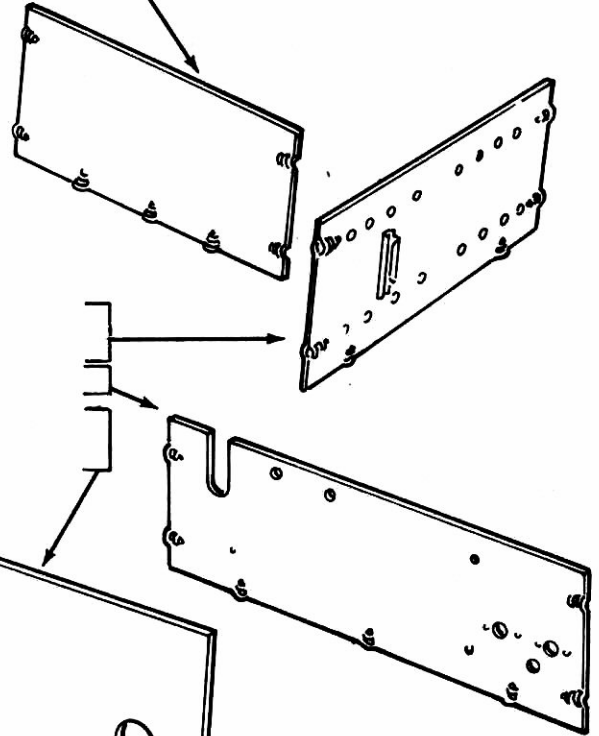

HARDWARE

#2, #3, and #4 Hardware

() 4	2-56 x 11/16" screw	250-352
() 4	2-56 nut	252-51
() 1	3-48 nut	252-1
() 2	4-40 x 1/8" setscrew	250-156
() 12	4-40 x 1/2" T-bolt	250-1194
() 4	4-40 x 1/4" nut	252-2
() 12	4-40 nut	252-15
() 6	#3 lockwasher	254-7
() 21	#4 lockwasher	254-9

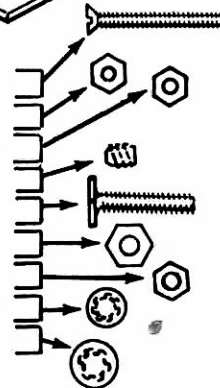

QTY.	DESCRIPTION	HEATH No.	CIRCUIT Component No.
#6 Hardware			
() 2	6-32 x 3/8" flat head screw	250-32	
() 46	6-32 x 3/8" screw	250-89	
() 4	#6 x 3/8" flat head sheet metal screw	250-441	
() 4	#6 x 3/8" hex head sheet metal screw	250-475	
() 10	6-32 x 1/2" screw	250-162	
() 71	#6 x 1/2" hex head sheet metal screw	250-1195	
() 4	#6 x 5/8" hex head sheet metal screw	250-1199	
() 2	#6 x 3/4" hex head sheet metal screw	250-298	
() 2	6-32 x 1-3/8" screw	250-168	
() 42	6-32 nut	252-3	
() 1	6-32 knurled nut	252-23	
() 40	#6 lockwasher	254-1	
() 23	#6 solder lug	259-1	
#8 and #10 Hardware			
() 9	8-32 x 3/16" setscrew	250-16	
() 4	10-32 x 1/2" screw	250-456	
() 8	#10 flat washer	253-19	
Other Hardware			
() 2	1/4-32 nut	252-39	
() 7	Control nut	252-76	
() 1	3/8-32 knurled nut	252-86	
() 6	3/8" OD flat washer	253-60	
() 4	Control lockwasher	254-5	
() 8	Control flat washer	253-10	
() 2	1/8" long spacer	255-1	
() 4	17/32" long spacer	255-741	
() 4	3/8" long spacer	255-3	
() 1	3/8" long hex spacer	255-195	
() 3	Control solder lug	259-10	
() 2	1/4" ID lockwasher	254-14	

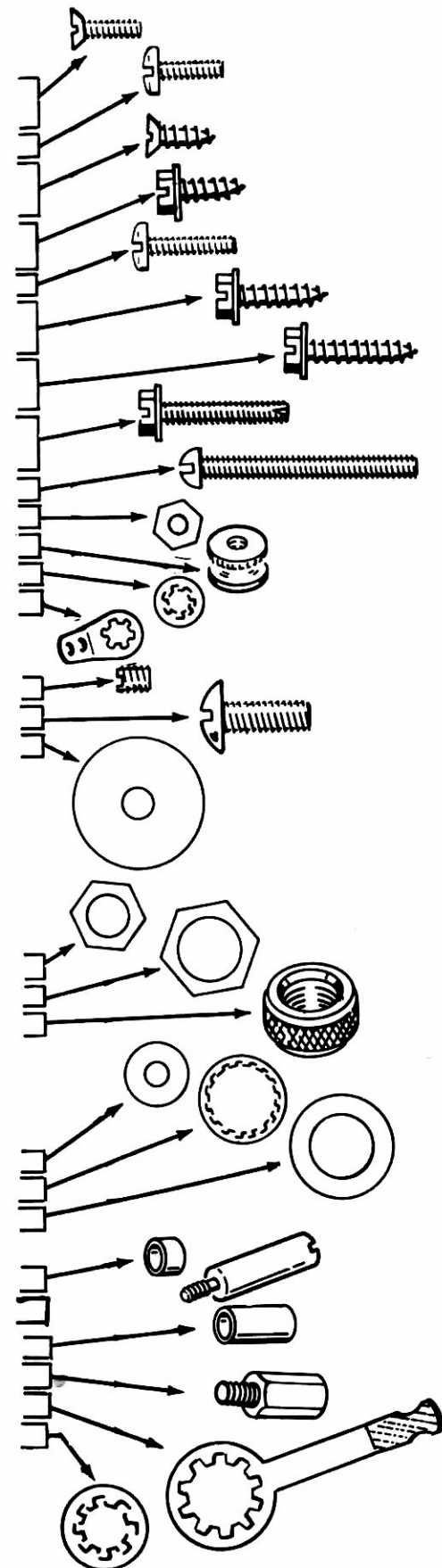

QTY.	DESCRIPTION	HEATH No.	CIRCUIT Component No.
------	-------------	-----------	-----------------------

CONNECTORS-SOCKETS

()	3	Spring clip	260-16
()	1	Microphone cable connector	432-38
()	1	Microphone panel connector	432-39
()	26	Wire connector	432-120
()	4	Male terminal	432-854
()	30	Chassis connector	432-180

()	1	Female connector housing	432-818
()	14	Phono socket	434-42
()	1	Pilot lamp socket	434-88
()	1	Pilot lamp socket	434-44

()	2	Transistor socket	434-117
()	1	11-pin socket	434-118
()	1	Octal plug cap	440-1

()	2	Retaining ring	435-1
()	1	Phone jack	436-19
()	10	Phono plug	438-4
()	6	Phono plug, 3/8" tip	438-46
()	2	11-pin plug	438-29

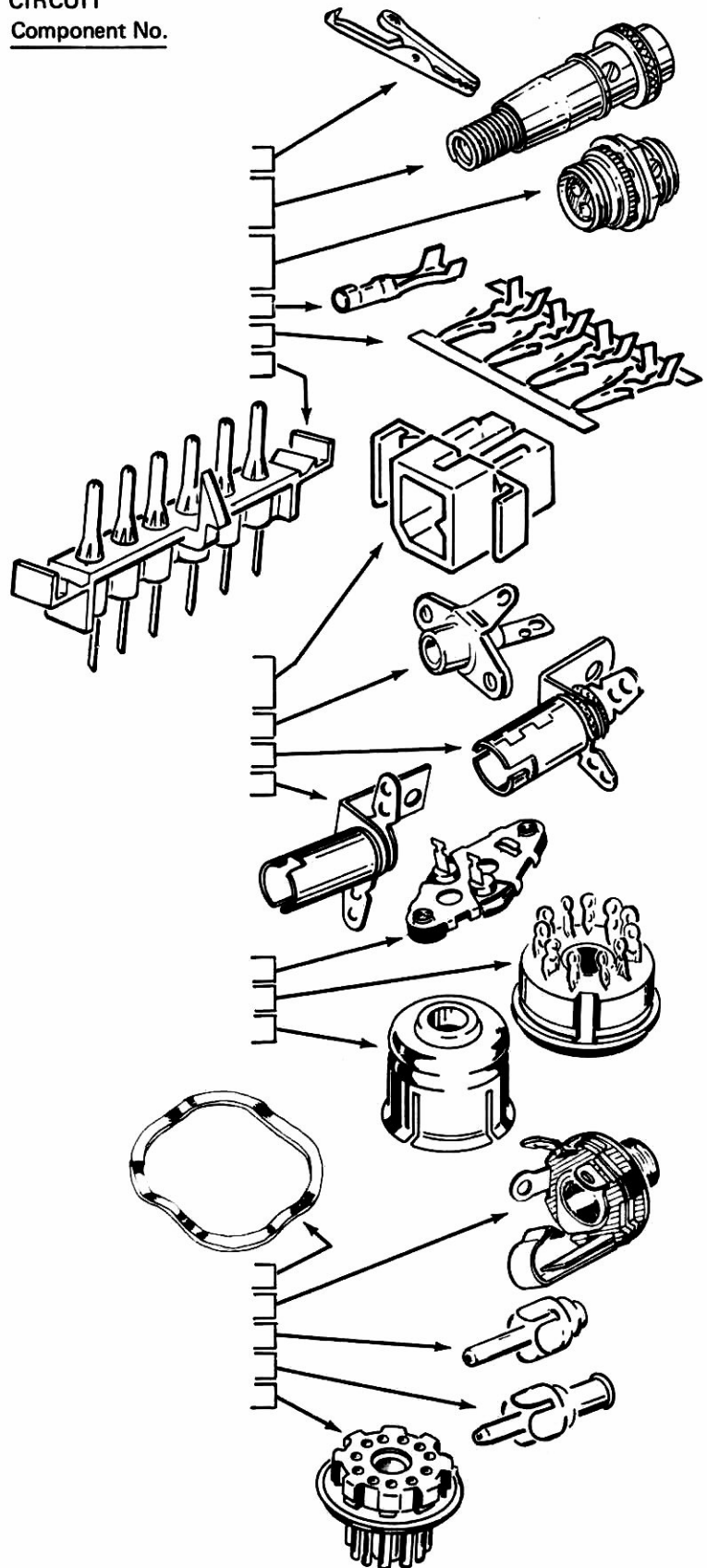

QTY.	DESCRIPTION	HEATH No.	CIRCUIT Component No.
------	-------------	-----------	-----------------------

SHAFTS-BUSHINGS

() 1 5-1/4" shaft 453-249

() 1 8" shaft 453-250

() 2 Shaft collar 455-15

KNOBS

() 2 Tapered knob 462-175

() 5 Small knob 462-933

() 1 Large knob 462-906

MISCELLANEOUS

() 1 Wiring harness 134-887

() 3 Small ferrite bead 475-10 FB (2)

() 4 5/16" ferrite bead 475-12 FB (4)

() 1 Red window 446-628

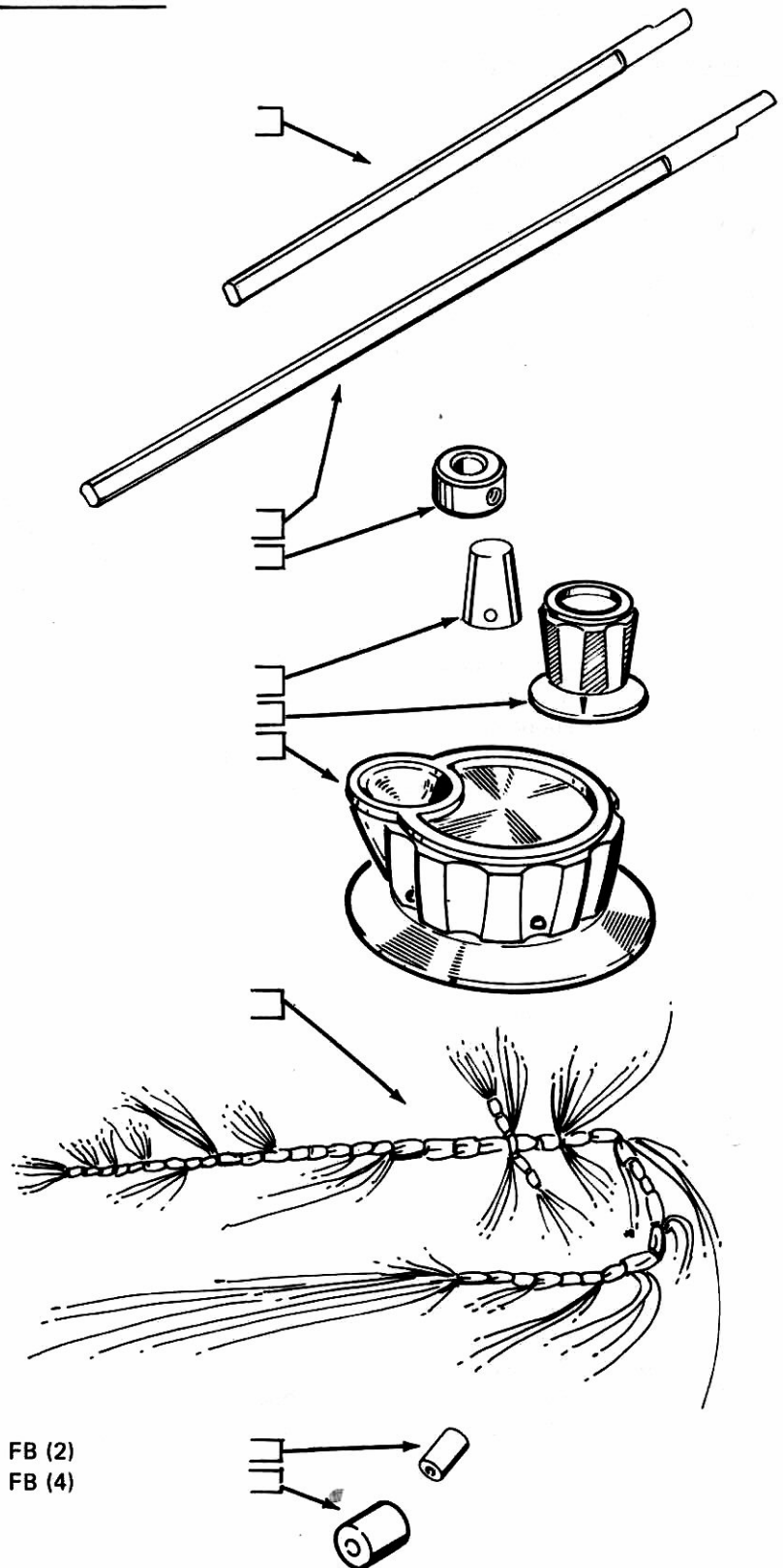

QTY.	DESCRIPTION	HEATH No.	CIRCUIT Component No.
() 2	11-lug terminal strip	431-49	
() 1	Cable harness	134-886	

MISCELLANEOUS (cont'd.)

() 2	Lamp shield	206-86
() 1	Heat sink	215-79

() 2	Tapered foot	255-59
() 4	Rubber foot	261-9
() 3	Thermal compound*	352-31

() 1	Meter	407-187
() 2	#1813 lamp	412-58

() 1	Insulated screwdriver	490-71
() 1	Circuit board packing carton	380-846

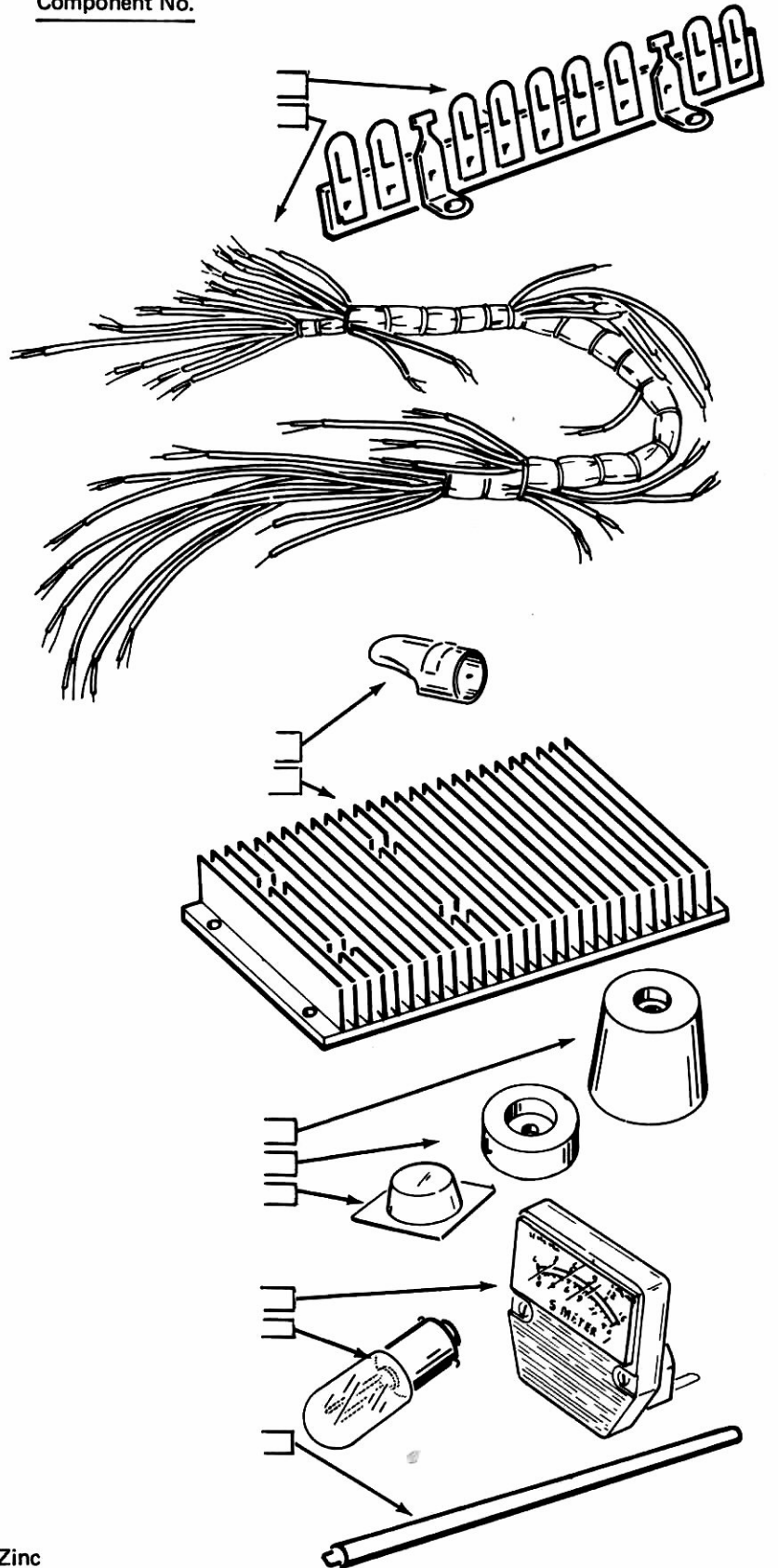

*Dow Corning thermal heat sink compound contains Zinc Oxides, SiO₂, and slight traces of CO₂.

<u>QTY.</u>	<u>DESCRIPTION</u>	<u>HEATH No.</u>	<u>CIRCUIT Component No.</u>
Miscellaneous (cont'd.)			
() 1	Identification strip (clear)	446-640	
() 1	Diffuser strip (frosted)	446-641	
() 1	Allen wrench	490-23	
() 1	Coil alignment tool	490-1	
() 1	Receiver front end circuit board assembly*	181-2203	
() 1	Transmitter IF circuit board assembly*	181-2711	

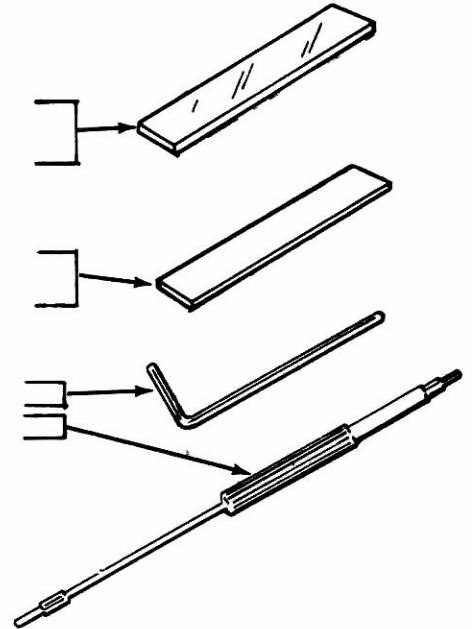

To order a replacement part, always include the PART NUMBER. Use the Parts Order Form furnished with this kit. If one is not available, see "Replacement Parts" inside the rear cover of this Manual. Your Warranty is located inside the front cover. For pricing information, refer to the separate "Heath Parts Price List."

***CAUTION:** This circuit board has been pretested and aligned. Do not tamper with this circuit board; to do so could decrease performance and will void the Warranty.

STEP-BY-STEP ASSEMBLY

CHASSIS PARTS MOUNTING

Refer to Pictorial 12-1 (Illustration Booklet, Page 3) for the following steps.

- (1) Find the 4-40 x 1/4" nuts, #252-2, and lay them aside. They will be used later for mounting the display circuit board.
- (2) Position the chassis with the bottom side up as shown in the Pictorial.

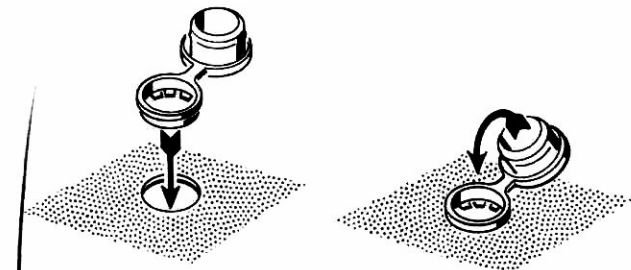

POSITION THE SMALL PORTION OF THE GROMMET INTO THE CHASSIS HOLE.

BEND THE LARGE PORTION OF THE GROMMET OVER AND INTO THE SMALL PORTION. PRESS IT FIRMLY INTO PLACE.

Detail 12-1A

- (3) Refer to Detail 12-1A and install large plastic grommets in holes BA, BB, BC, and BD.

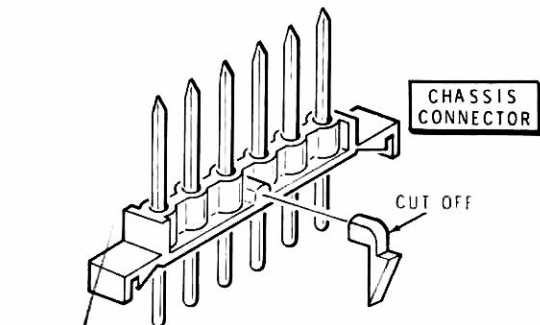

Detail 12-1B

- (4) Refer to Detail 12-1B and cut the arrow-shaped lug from 30 chassis connectors.

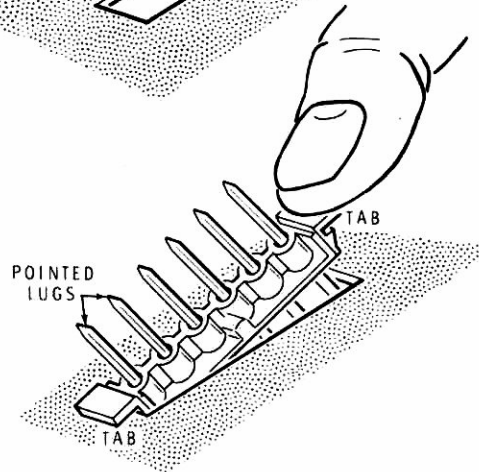
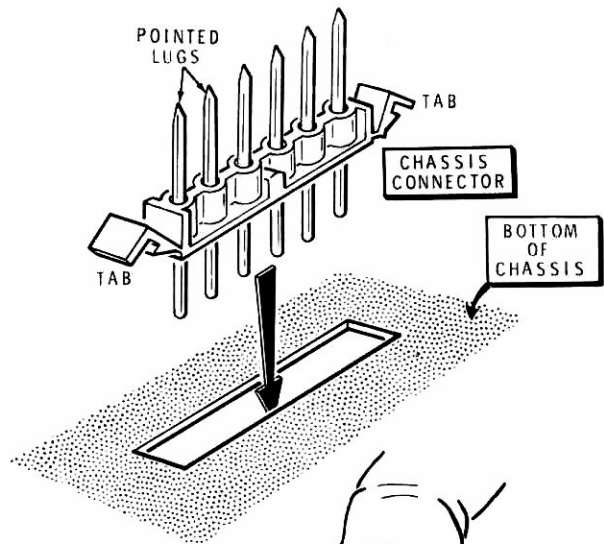

Detail 12-1C

- (5) Refer to Detail 12-1C and install the chassis connectors in the 30 rectangular openings in the chassis. DO NOT install a chassis connector at AD, which will be used only if you install the accessory noise blanker. Install each connector with the rounded terminals down. Bend the tabs of the connector up, place the slotted tab against one end of the opening, and push the other end of the connector down until it snaps into place (use a screwdriver blade, if necessary).

NOTE: The terminal identification labels which will be installed in the following steps will positively identify each of the plug-in terminals. It is very important that you affix each label at the correct connector and that you align each number with its pin as shown in the inset drawing of the Pictorial. To install a label, remove the number strips from the paper backing, align the numbers with the terminals, and press the label carefully into position. Refer to the Pictorial for the position of each label. A pair of tweezers may help in positioning the labels.

- () Remove and affix the four rows of A labels.
- (✓) Similarly, affix the four rows of B labels and the four rows of C labels.

- () Affix the four rows of E labels.
- () Affix the four rows of F labels.
- () Affix the four rows of G labels.
- () After carefully noting their positions, affix the H, J, K, and L labels.
- () Compare the holes in a transistor socket insulator with the chassis holes at Q1 and Q2. Note that the two holes in the center are offset so the insulator can be installed only one way.

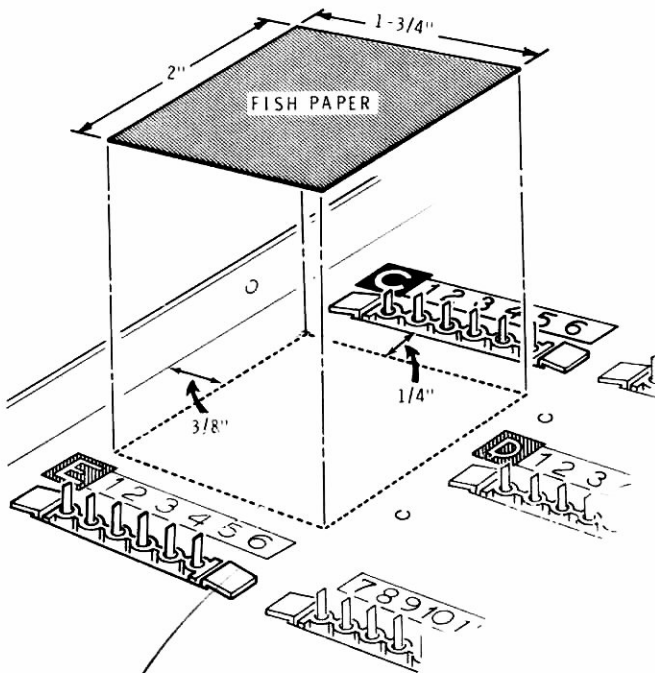

Detail 12-1D

- () Refer to Detail 12-1D and install the piece of gray fish paper. Remove and discard the protective covering. Center the 1-3/4" edge of the paper about 1/4" below connector C1-6, place the adhesive side of the gray paper against the chassis, and rub it into place.
- (✓) Remove the four rows of D labels. Discard row D19-24. Then affix the other three rows.

WARNING: You will be using Dow Corning 340 thermal heat sink compound in the next step and in several other steps in the Manual. Although the compound is not caustic, it may cause temporary discomfort if it gets into your eyes. Should this happen, rinse your eyes with warm water. If the compound gets into your clothing, the clothing may require professional cleaning. The compound contains Zinc Oxides, SiO₂, and slight traces of CO₂.

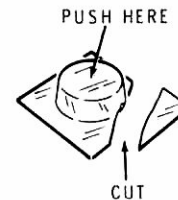

Detail 12-1E

- () Refer to Detail 12-1E and open one of the thermal compound pods by cutting across the corner and into the pod just enough to make a small opening. Use diagonal cutters or scissors.



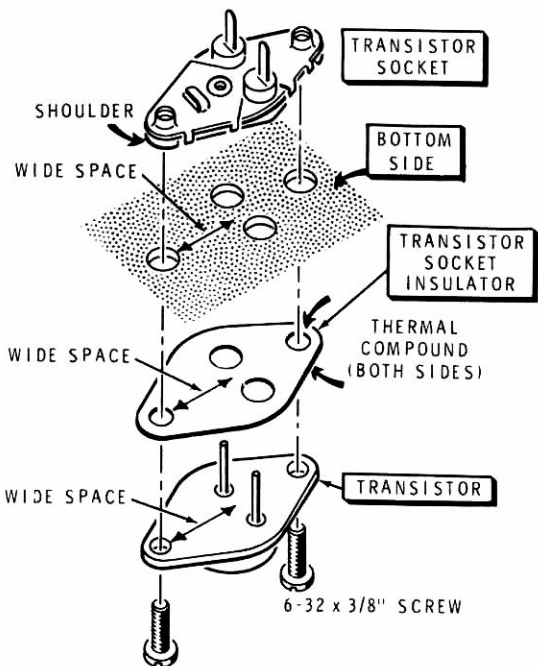

Detail 12-1F

NOTE: In the following steps, handle the socket insulators carefully.

- (✓) Squeeze an amount of thermal compound equal to a small pea onto each side of a transistor socket insulator. Spread the compound completely over both sides of the insulator. Then, on the TOP side of the chassis, place the insulator over the chassis holes at Q2. Make sure the insulator holes are aligned with the chassis holes. WASH YOUR HANDS.
- (✓) Q2: Refer to Detail 12-1F and install an MHT9210 transistor (#417-162) on top of the chassis and a transistor socket on the bottom of the chassis at Q2. Use 6-32 x 3/8" screws in the tapped holes of the sockets. Make sure the two shoulders around the socket holes fit into the chassis holes.
- (✓) Wipe the excess thermal compound from the transistor.
- (✓) Q1: In the same manner, prepare the other transistor socket insulator and mount an MHT9210 transistor and a transistor socket at Q1.
- () Use an ohmmeter to make a resistance reading from each pin and from the body of each transistor to the chassis. The ohmmeter should read infinitely high on any range. If it does not, the transistor, the socket, and the insulator should be remounted.

NOTE: When hardware is called for in a step, only the screw size will be given. For instance, if "6-32 x 3/8" hardware" is called for, it means that a 6-32 x 3/8" screw, one or more #6 lockwashers, and a 6-32 nut should be used for each mounting hole. The Detail referred to in the step will show the proper number of lockwashers to use.

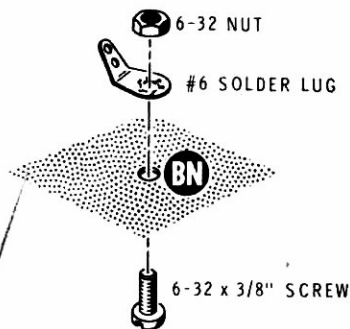

Detail 12-1G

(✓) Refer to Detail 12-1G and mount a #6 solder lug at BN. Use 6-32 x 3/8" hardware.

(✓) R14. Refer to Detail 12-1H and mount the 16 Ω, 24-watt resistor at R14 with the raised boss toward the chassis. Use 6-32 x 1/2" hardware. DO NOT overtighten the screw as the resistor body can be broken.

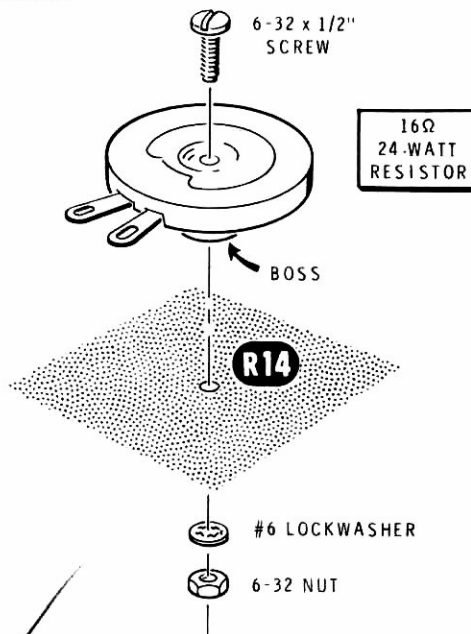

Detail 12-1H

(✓) Mount two #6 solder lugs at BK. Position the lugs as shown. Use 6-32 x 3/8" hardware.

(✓) Mount a #6 solder lug at BJ. Use 6-32 x 3/8" hardware.

Refer to Pictorial 12-2 (Illustration Booklet, Page 4) for the following steps.

Refer to Detail 12-2A and prepare an 11-lug terminal strip. You can use diagonal cutters to cut through the terminal strip insulator. Save the indicated pieces for use later. Lay the prepared terminal strips aside temporarily.

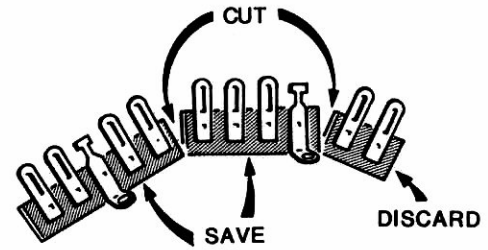

Detail 12-2A

Refer to Detail 12-2B and loosely assemble seven circuit board shields to the PA shield, the lateral shield, and the left side panel. Be sure the screw tabs on all long edges are on the same side of the assembly. Use #6 x 1/2" hex head sheet metal screws.

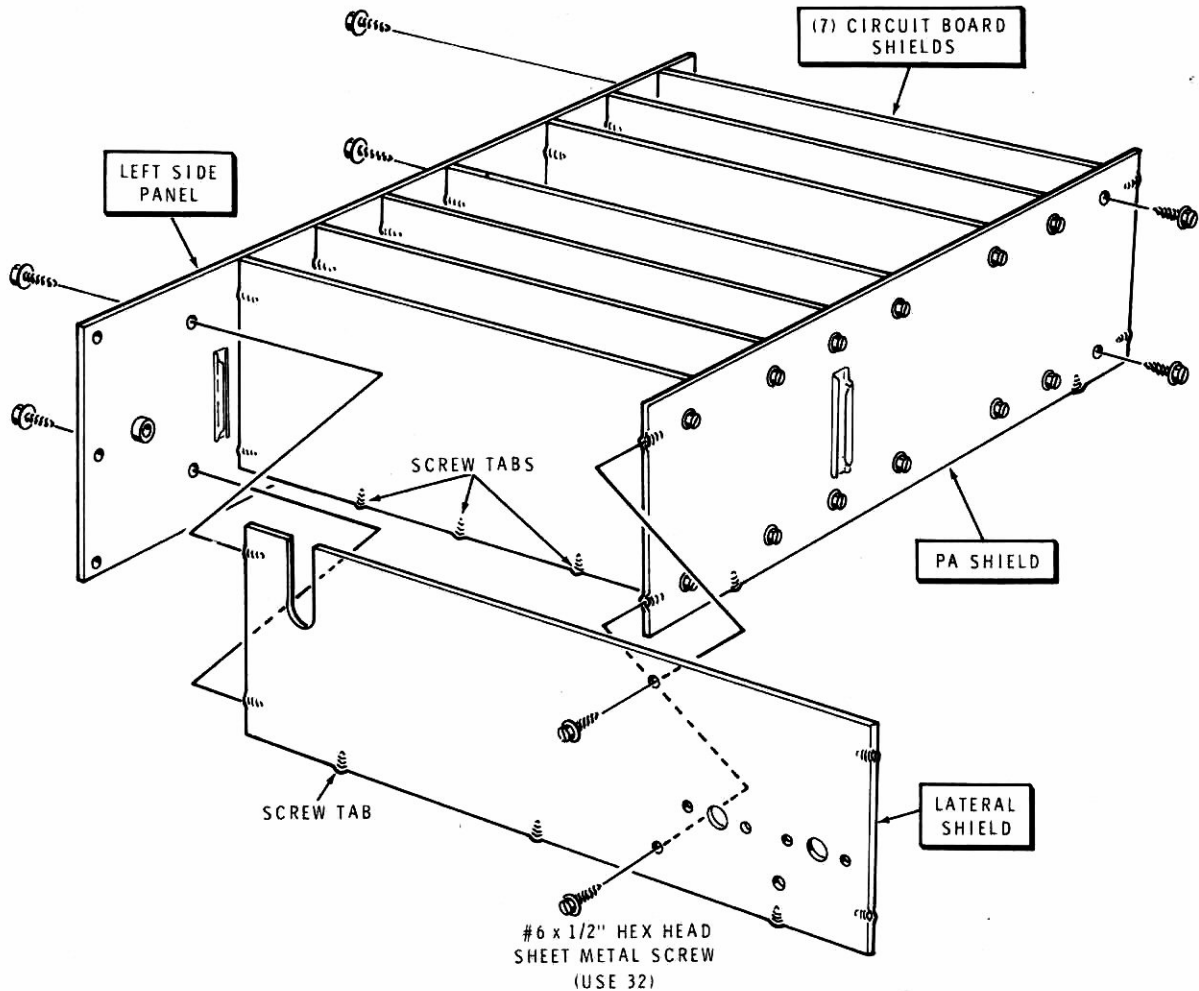

Detail 12-2B

Refer to Detail 12-2C (Illustration Booklet, Page 5) for the next four steps.

- () Secure the shield assembly to the top of the chassis with #6 x 1/2" hex head sheet metal screws at holes BX, BY, and BZ.
- () Tighten the shield assembly screws in the following sequence:
 1. Left side panel screws except the two holding the lateral shield.
 2. All screws in the PA shield.
 3. Two screws holding the PA shield to the lateral shield.
 4. Two screws holding the lateral shield to the left side panel.
- () Mount the prepared 4-lug terminal strip at hole BE as shown in Detail 12-2C. Use one #6 lockwasher and a #6 x 1/2" hex head sheet metal screw. The terminal strip foot should point away from the large chassis cutout.
- () Install #6 x 1/2" hex head sheet metal screws at holes BF, JA, and JB as shown.
- () Refer to Detail 12-2D and install a #6 solder lug and a #6 x 1/2" hex head sheet metal screw at BM. Position the solder lug as shown. (Also, see Pictorial 12-3 on Page 6 of the Illustration Booklet.)
- () Cut out two letters G ("GG") from the label sheet, remove the protective backing, and press the adhesive side against the circuit board shield as shown in Pictorial 12-2. Be sure you select the proper shield.
- () Similarly, apply double letters F through A to the other shields, as shown.
- () View the shield assembly from above. If any of the circuit board shields are not straight (are bowed), straighten them as much as possible by bending them.
- () Refer to Detail 12-2E and mount the relay on the chassis at RY. Use a #3 lockwasher and a 3-48 nut.

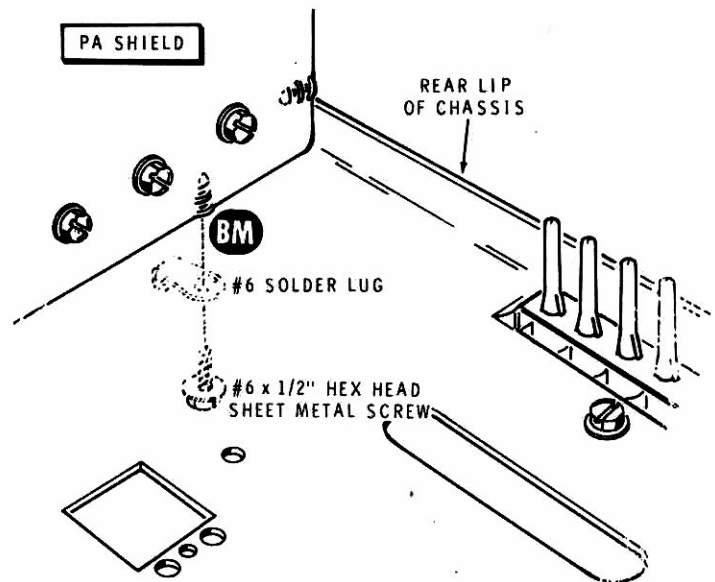

Detail 12-2D

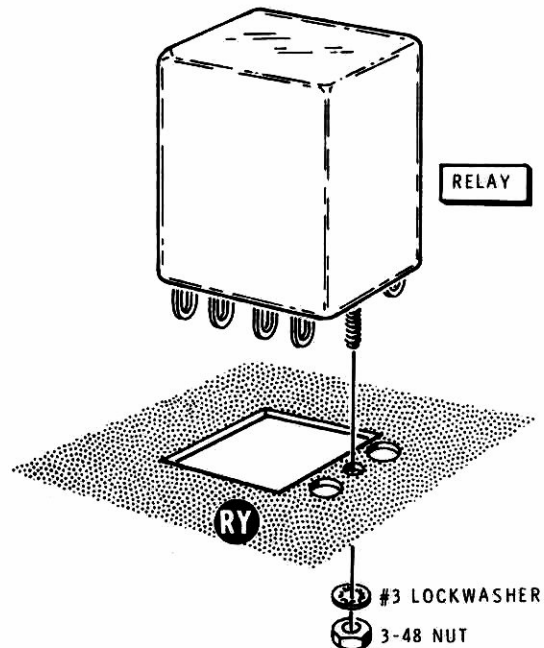

Detail 12-2E

Refer to Pictorial 12-3 (Illustration Booklet, Page 6) for the following steps.

NOTE: Be sure to position the solder lugs as shown in the Pictorial.

In the following steps, mount #6 solder lugs with #6 x 1/2" hex head sheet metal screws.

- () Install a solder lug at AF.
- () Install a solder lug at AG.
- () Install a solder lug at AH.
- () Install two solder lugs at AJ.
- () Install a solder lug at AL.
- () Install a solder lug at AN.
- () Install two solder lugs at AP.
- () Install a solder lug at AR.
- () Install two solder lugs at AS.
- () Install a solder lug at AT.
- () Install a solder lug at AU.
- () Install a solder lug at AW.

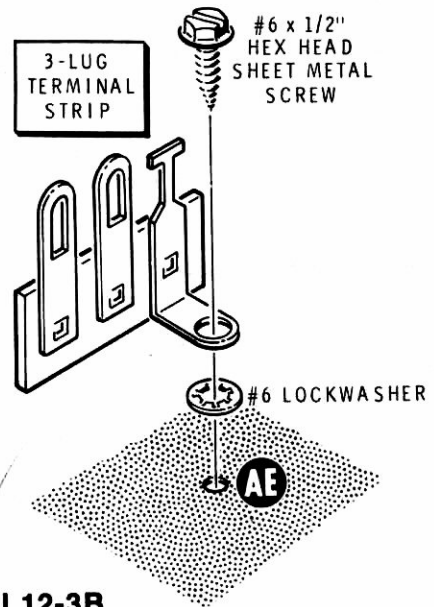

Detail 12-3B

- (✓) Refer to Detail 12-3A and prepare an 11-lug terminal strip as shown.
- (✓) Refer to Detail 12-3B and mount the prepared 3-lug terminal strip at AE with a #6 x 1/2" hex head sheet metal screw and a #6 lockwasher. Be sure to position the terminal strip as shown in the Pictorial.
- () Refer to Detail 12-3C and mount the prepared 4-lug terminal strip at BP with a #6 x 1/2" hex head sheet metal screw and a #6 lockwasher. Be sure to position the terminal strip as shown in the Pictorial.

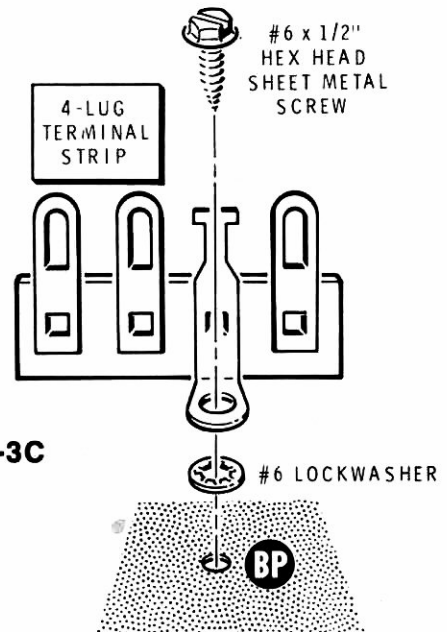
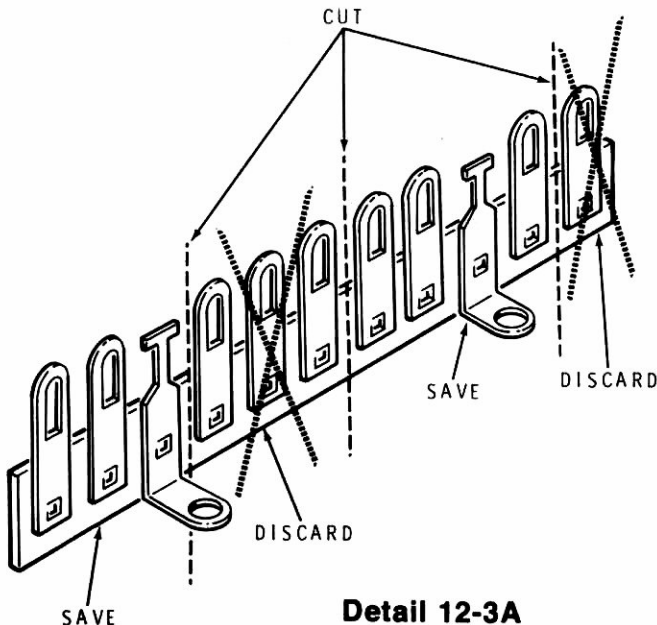

Detail 12-3C

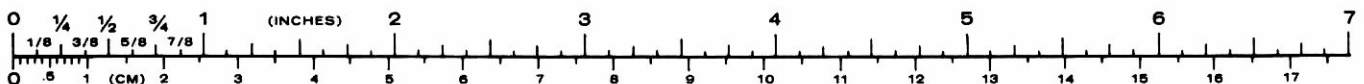

() Leave holes AK and AM open, and install #6 x 1/2" hex head sheet metal screws in the remaining open holes marked with arrows.

() Tighten all sheet metal screws.

CHASSIS WIRING

NOTE: When you solder a wire to a terminal of a chassis connector, wrap the end of the wire tightly around the terminal as close to the connector body (or previously installed wire) as possible. Place the tip of your soldering iron against the terminal and the wire and heat the parts thoroughly. Then touch the end of the solder to the joint and melt a small amount of solder on the parts. Be positive that each wire is soldered. Two or more wires may be soldered to one terminal at different times.

() Cut the following lengths of small bare wire. Wires are listed in the order in which they will be used.

- | | |
|--------|--------|
| 2-1/4" | 1-3/4" |
| 1-3/4" | 1-1/4" |
| 1-1/2" | 2-1/2" |
| 2-1/4" | |

Refer to Pictorial 12-4 (Illustration Booklet, Page 7) for the following steps.

Install small bare wires as follows:

() 2-1/4" from the lower hole of solder lug AH (NS) to terminal C2 (S-1).

() 1-3/4" from the lower hole of solder lug AH (S-2) to terminal C9 (S-1).

() 1-1/2" from solder lug AJ (NS) to terminal B22 (S-1).

() 2-1/4" from solder lug AJ (S-2) to terminal C23 (S-1).

() 1-3/4" from the lower hole of solder lug AL (NS) to terminal D3 (S-1).

() 1-1/4" from the lower hole of solder lug AL (S-2) to terminal D5 (S-1).

() 2-1/2" from the lower hole of solder lug AN (S-1) to terminals D16, D17, and D18. The wire should touch terminals D16 and D17 and encircle D18. Solder the wire to the three terminals.

() Cut the following lengths of small bare wire:

- | | |
|--------|--------|
| 2-1/4" | 2-3/4" |
| 1-1/2" | 3" |

Install small bare wires as follows:

() 2-1/4" from the lower hole of solder lug AY (S-1) to terminal E2 (S-1).

() 1-1/2" from the lower hole of solder lug AP (S-1) to terminal E8 (S-1).

NOTE: Where a wire passes through a connection and then goes to another point, as in the next step, it will count as two wires in the solder instructions (S-2) one entering and one leaving the connection. Be especially careful, when soldering these connections, to apply enough solder and heat to solder these "through wires."

() 2-3/4" from terminal F12 (S-1) through the lower hole of solder lug AR (S-2) to terminal F13 (S-1).

() 3" from terminal F18 (S-1) through solder lug AZ (S-2) to terminal F20 (S-1).

Cut the following lengths of small bare wire:

- | | |
|--------|--------|
| 3-1/2" | 1-1/4" |
| 1-3/4" | 2-1/2" |
| 2-1/2" | 1-1/4" |
| | 1-1/4" |

Refer to Pictorial 12-4 (Illustration Booklet, Page 7) for the following steps.

Install small bare wires as follows:

() 3-1/2" from terminal E22 (S-1), through the lower hole of solder lug AS (S-2) to terminals F22, F23, and F24. The wire should touch terminals F22 and F23 and should encircle F24. Solder the wire to the three terminals.

() 1-3/4" from terminal F2 (S-1) to the lower hole of solder lug AT (NS).

() 2-1/2" from terminal F6 (S-1), through the lower hole of solder lug AT (NS), to terminal G3 (S-1).

() 1-1/4" from terminal G5 (S-1) to the lower hole of solder lug AT (S-4).

() 2-1/2" from terminal G12 (S-1), through solder lug AU (S-2), to terminal G16 (S-1).

() 1-1/4" from terminal G19 (S-1) to solder lug AW (S-1). Route this wire as shown.

() 1-1/4" from terminal G23 (S-1) to solder lug BM (S-1).

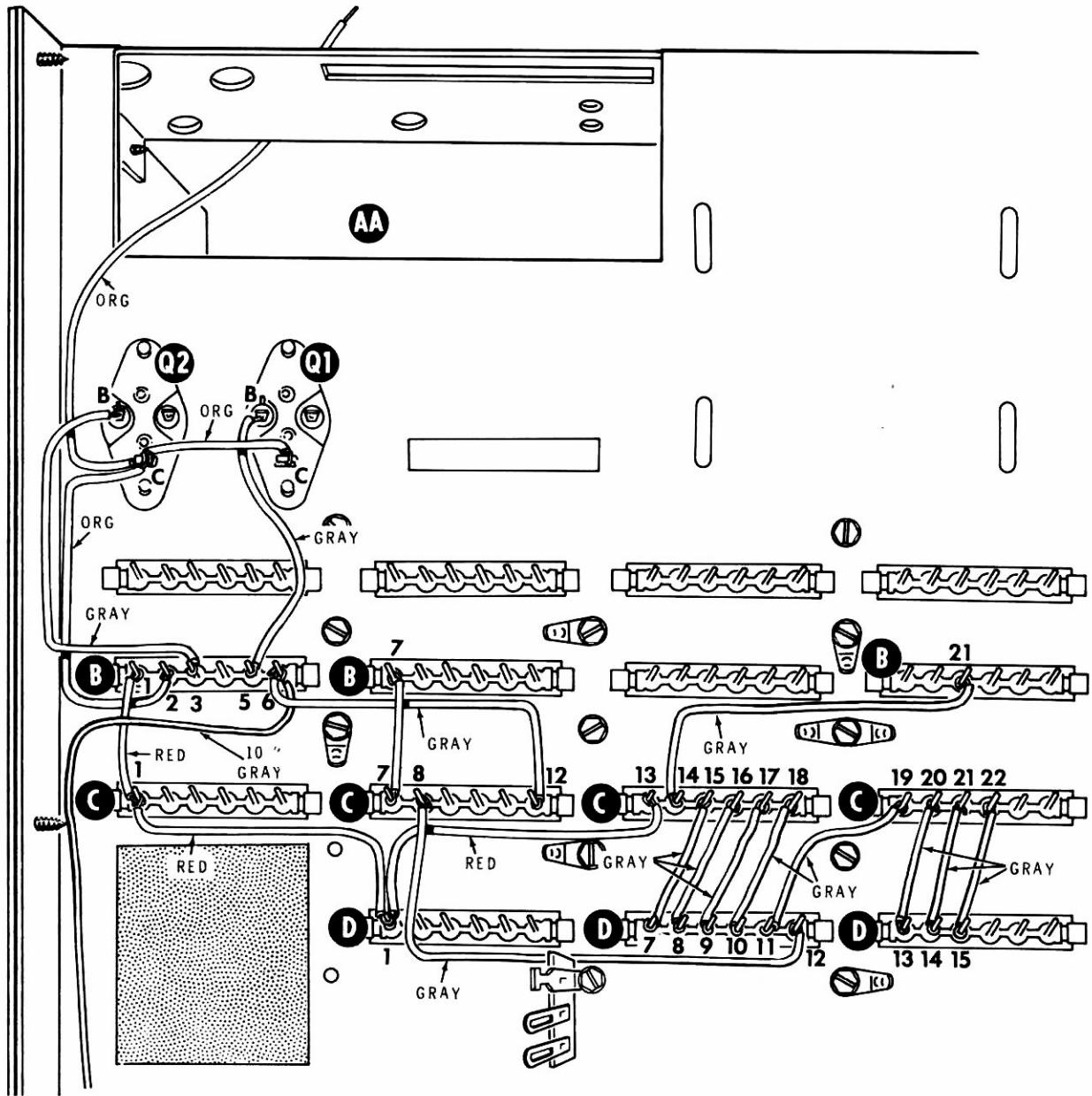

PICTORIAL 12-5

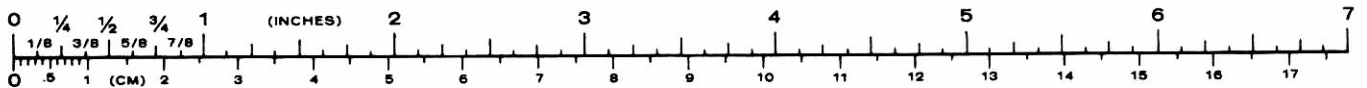

Refer to Pictorial 12-5 for the following steps.

NOTE: When wiring this kit, you will be instructed to prepare the lengths of wire ahead of time, as in the following steps. To prepare a wire, cut it to the indicated length and remove 1/4" of insulation from each end. The wires are listed in the order in which they will be used.

() Prepare the following solid (insulated) wires. NOTE: Do not use the stranded wire unless it is called for.

1-3/4" orange	3-3/4" red
4" orange	4" red
7" orange	10" gray
4-1/2" gray	4" gray
3" gray	1-1/2" gray
1-1/2" red	4" gray

Connect the prepared wires as follows:

() 1-3/4" orange from lug C of Q1 (NS) to lug C of Q2 (NS).

() 4" orange from lug C of Q2 (NS) to terminal B2 (S-1).

() 7" orange to lug C of Q2 (S-3). Push the other end of this wire up through chassis cutout AA.

() 4-1/2" gray from lug B of Q2 (NS) to terminal B3 (S-1).

() 3" gray from lug B of Q1 (S-1) to terminal B5 (S-1). DO NOT use so much solder that it runs down the lug and solders the transistor lead to the socket.

NOTE: To avoid the possibility of a missed solder connection, each wire (with a few exceptions) will be soldered at the time it is connected to a chassis connector terminal. To aid you in checking your work, if one or more wires have previously been soldered to the terminal, the solder step will indicate it. For example, the solder step for the first wire connected to terminal B14 will read (S-1); for the second wire, the solder step will read (S-1/2); for the third wire, the solder step will read (S-1/3).

() 1-1/2" red from terminal B1 (S-1) to terminal C1 (S-1).

() 3-3/4" red from terminal C1 (S-1/2) to terminal D1 (S-1).

() 4" red from terminal C13 (S-1) to terminal D1 (S-1/2).

() 10" gray to terminal B6 (S-1). Position this wire as shown. The other end will be connected later.

() 4" gray from terminal B6 (S-1/2) to terminal C12 (S-1).

() 1-1/2" gray from terminal B7 (S-1) to terminal C7 (S-1).

() 4" gray from terminal B21 (S-1) to terminal C14 (S-1).

() Prepare the following solid wires:

One 5" gray
Seven 1-5/8" gray
One 2-1/4" gray

Connect the prepared wires as follows:

() 5" gray from terminal C8 (S-1) to terminal D12 (S-1).

() 1-5/8" gray from terminal C15 (S-1) to terminal D7 (S-1).

() 1-5/8" gray from terminal C16 (S-1) to terminal D8 (S-1).

() 1-5/8" gray from terminal C17 (S-1) to terminal D9 (S-1).

() 1-5/8" gray from terminal C18 (S-1) to terminal D10 (S-1).

() 2-1/4" gray from terminal C19 (S-1) to terminal D11 (S-1).

() 1-5/8" gray from terminal C20 (S-1) to terminal D13 (S-1).

() 1-5/8" gray from terminal C21 (S-1) to terminal D14 (S-1).

() 1-5/8" gray from terminal C22 (S-1) to terminal D15 (S-1).

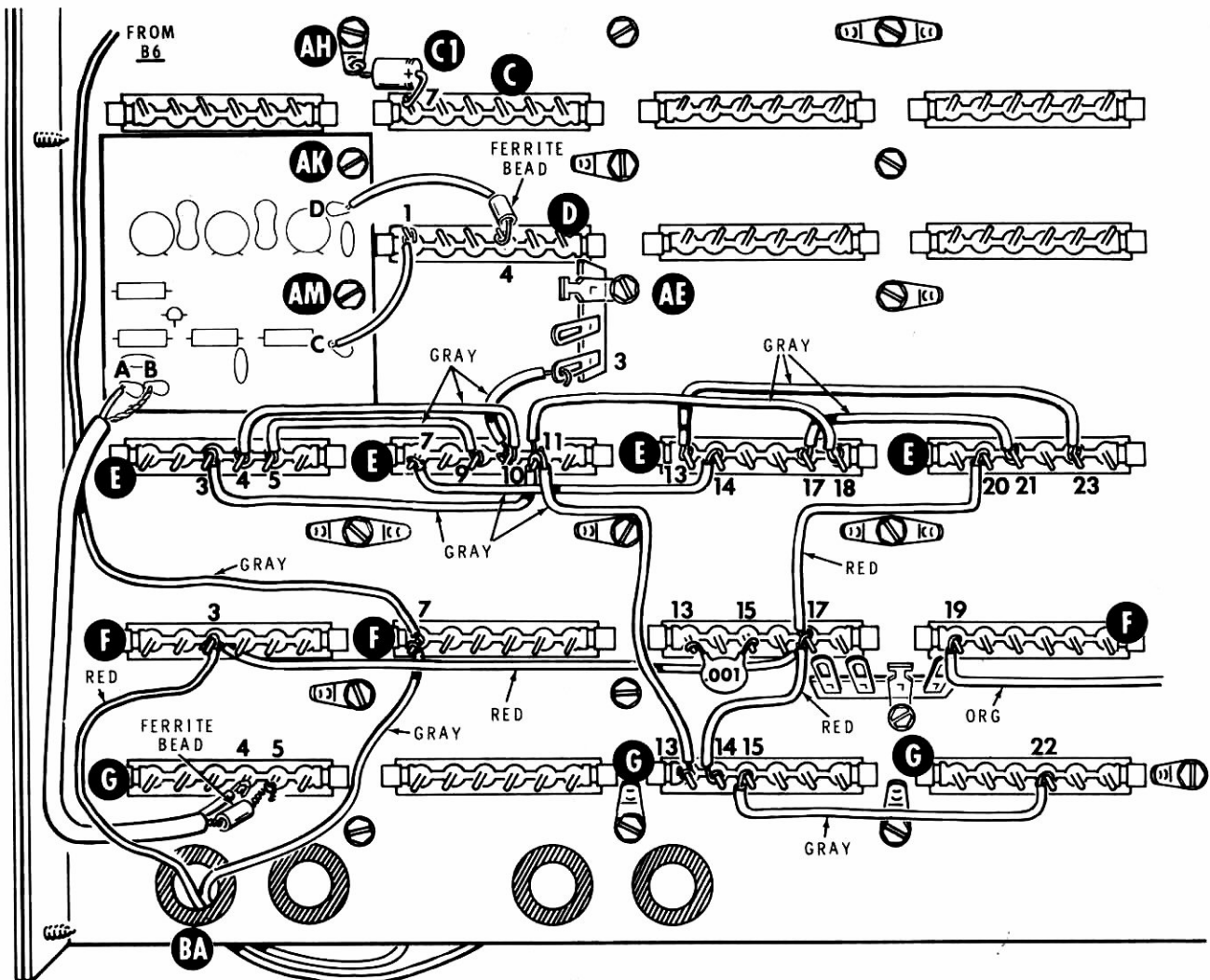

PICTORIAL 12-6

Refer to Pictorial 12-6 for the following steps.

1) Connect the end of the gray wire coming from terminal B6 to terminal F7 (S-1).

2) Prepare the following solid wires:

- 3" gray
- 1-3/4" gray
- 3" gray
- 3-1/2" gray
- 3-3/4" gray
- 4" gray
- 4-5/8" gray
- 4" gray

Connect the prepared wires as follows:

- 1) 3" gray from terminal E5 (S-1) to terminal E9 (S-1).
- 2) 1-3/4" gray from terminal E10 (S-1) to terminal strip AE lug 3 (NS).
- 3) 3" gray from terminal E17 (S-1) to terminal E21 (S-1).
- 4) 3-1/2" gray from terminal E4 (S-1) to terminal E10 (S-1/2).
- 5) 3-3/4" gray from terminal E11 (S-1) to terminal E18 (S-1).

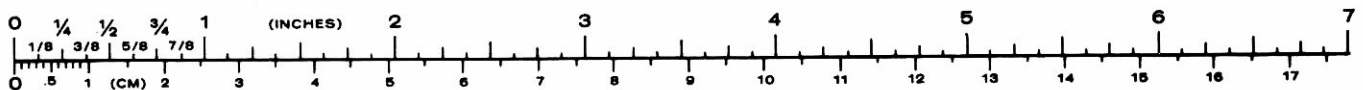

- (✓) 4" gray from terminal E3 (S-1) to terminal E11 (S-1/2).
- (✓) 4-5/8" gray from terminal E13 (S-1) to terminal E23 (S-1).
- (✓) 4" gray from terminal E7 (S-1) to terminal E14 (S-1).
- (✓) Prepare the following solid wires:

- 4-1/4" gray 6" red
- 3-1/2" red 3-3/4" gray
- 1-3/4" red 7" orange
- 9-3/4" red 14" gray

Connect the prepared wires as follows:

- (✓) 4-1/4" gray from terminal E11 (S-1/3) to terminal G13 (S-1).
- (✓) 3-1/2" red from terminal E20 (S-1) to terminal F17 (S-1).
- (✓) 1-3/4" red from terminal F17 (S-1/2) to terminal G14 (S-1).
- (✓) 9-3/4" red to terminal F3 (S-1). Push the other end of the wire through grommet BA. It will be connected later.
- (✓) 6" red from terminal F3 (S-1/2) to terminal F17 (S-1/3).
- (✓) 3-3/4" gray from terminal G15 (S-1) to terminal G22 (S-1).
- (✓) 7" orange to terminal F19 (S-1). The other end will be connected later.
- (✓) 14" gray to terminal F7 (S-1/2). Push the other end through grommet BA as far as possible.
- (✓) C1: Connect the positive (+) lead of a 10 μ F electrolytic capacitor to C7 (S-1/2). Connect the other lead to the upper hole of solder lug AH (NS).
- (✓) C13: Connect a .001 μ F disc capacitor from terminal F13 (NS) to terminal F15 (NS).

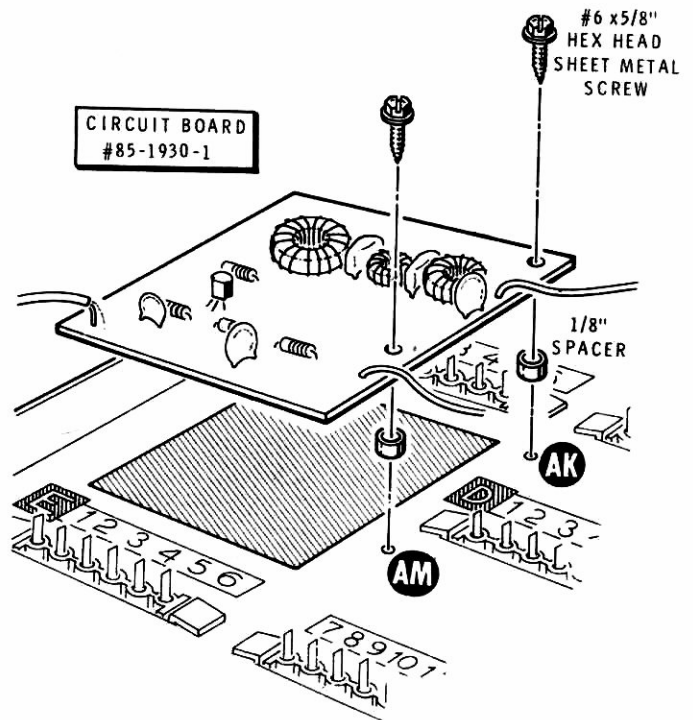

Detail 12-6A

- (✓) Refer to Detail 12-6A and install the VFO filter circuit board, #85-1930-1, at AK and AM. Use #6 x 5/8" hex head sheet metal screws and 1/8" long spacers.
- Connect the wires coming from the circuit board as follows:
- (✓) Remove an additional 1/4" (total 1/2") from the gray wire. Then place a small ferrite bead on the wire and connect the wire to terminal D4 (S-1).
 - (✓) Red wire to terminal D1 (S-1/3).
 - (✓) The center conductor of the coaxial cable coming from A to terminal G4 (S-1). Place a small ferrite bead on the shield wire. Then connect the shield wire to terminal G5 (S-1/2).

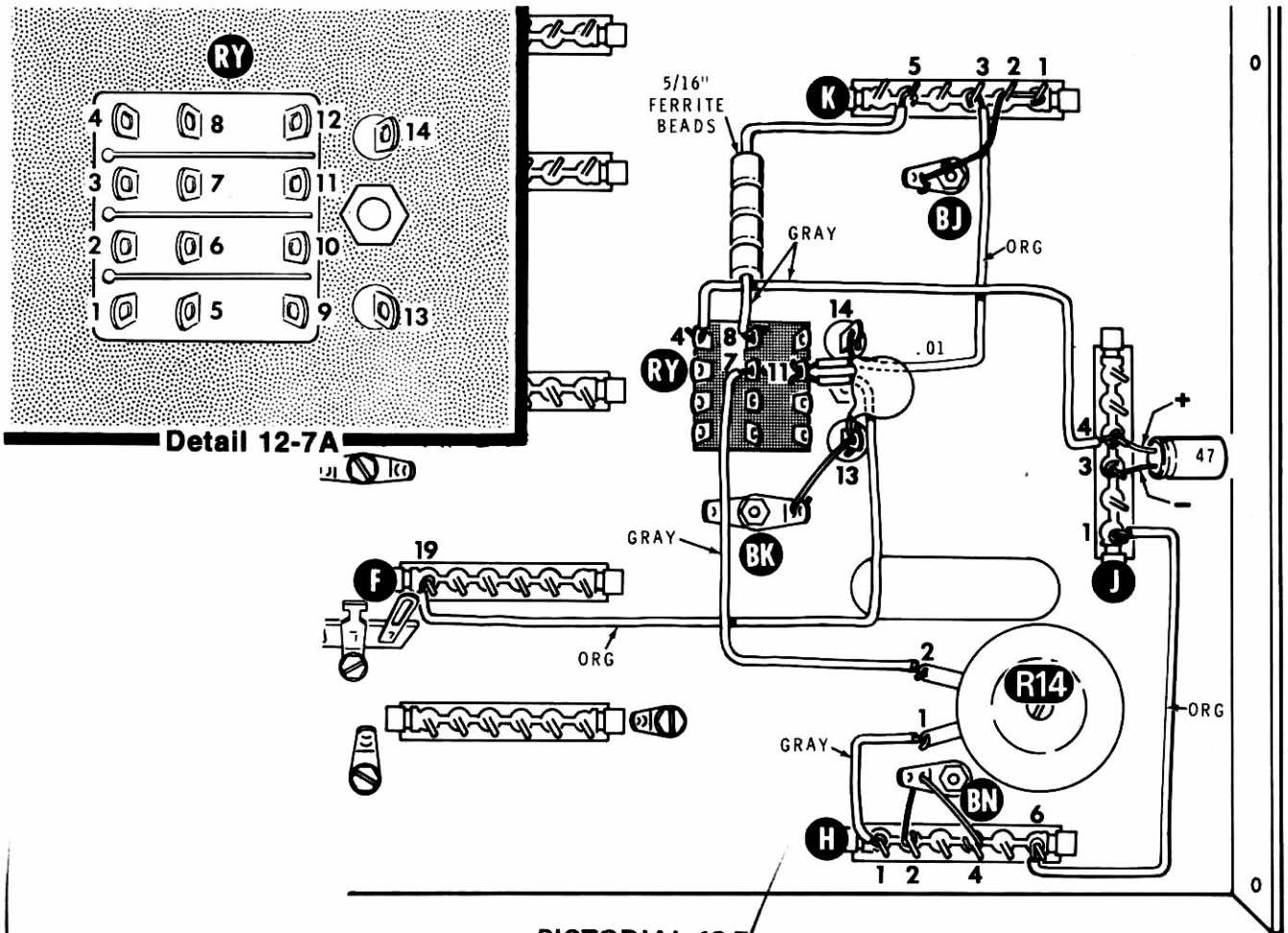

PICTORIAL 12-7

Refer to Pictorial 12-7 for the following steps.

() Prepare the following solid wires:

- | | |
|-----------|-------------|
| 4" orange | 4-1/4" gray |
| 5" orange | 1-3/4" gray |
| 5" gray | 3-3/4" gray |

Connect the prepared wires as follows:

NOTE: Refer to Detail 12-7A for the lug numbering of relay RY.

- () 4" orange from relay RY lug 11 (NS) to terminal K3 (S-1).
- () Connect the orange wire coming from terminal F19 to relay RY lug 11 (S-2).

- () 5" orange from terminal J1 (S-1) to terminal H6 (S-1).
- () 5" gray from relay RY lug 4 (S-1) to terminal J4 (S-1).
- () 4-1/4" gray from relay RY lug 7 (S-1) to R14 lug 2 (S-1).
- () 1-3/4" gray from R14 lug 1 (S-1) to terminal H1 (S-1).
- () Slide four 5/16" ferrite beads over the 3-3/4" gray wire.

NOTE: In the next step, apply a drop of cement to each ferrite bead. Then, when you install the gray wire, push the beads down against the chassis so the cement will hold them to the chassis.

- () 3-3/4" gray with ferrite beads from relay RY lug 8 (S-1) to terminal K5 (S-1).

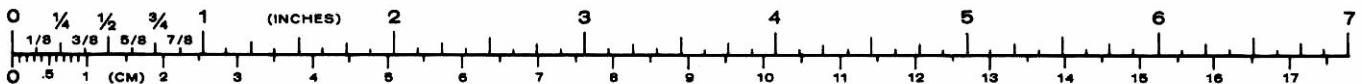

- (✓) Connect a 2" small bare wire from solder lug BJ (S-1) to terminals K2 and K1. The wire should touch terminal K2 and encircle terminal K1. Solder the wire to both terminals.
- (✓) Connect a 1" small bare wire from relay RY lug 13 (NS) to the lower hole of solder lug BK (S-1).
- (✓) Connect a 2" small bare wire from terminal H4 (S-1), through the lower hole of solder lug BN (S-2), to terminal H2 (S-1).
- (✓) C5: Connect a .01 μ F disc capacitor between relay RY terminals 13 (NS) and 14 (NS).
- (✓) C2: Connect a 47 μ F electrolytic capacitor between terminals J3 (S-1) and J4 (S-1/2). Be sure to connect the lead marked by a + mark to terminal J4 or the lead marked by a - mark to J3.

- (✓) Connect a 1" red wire from section C lug 1 (S-1) to section D lug 1 (S-1).
- (✓) Connect a 1-1/2" red wire from section A lug 5 (S-1) to section B lug 5 (NS).
- (✓) Connect a 2" gray wire from section D lug 5 (S-1) to section E lug 2 (NS).
- (✓) Connect a 2-1/2" red wire from section B lug 5 (S-2) to section D lug 2 (NS).
- (✓) Connect one end of a 4" red wire to section D lug 2 (S-2). The other end of the wire will be connected later.
- (✓) Connect a 1-1/2" red wire from section C lug 5 (NS) to section D lug 4 (S-1).
- (✓) Connect a 6" red wire to section C lug 5 (NS). The other end of this wire will be connected later.

Prepare the following wires:

- Two 1-1/2" orange
- 7" gray
- 1-1/2" gray
- 4-3/4" gray
- 9" gray
- 4" gray

Pushbutton Switch Prewiring

Refer to Pictorial 12-8 (Illustration Booklet, Page 7) for the following steps.

Prewire pushbutton switch S3 (#64-673) as follows:

- (✓) Insert a 1-1/2" small bare wire through lugs 1 and 2 of switch sections A and B. DO NOT solder the wire at section B lug 2, but solder the other three lugs.

NOTE: To prepare a wire, cut it to length and remove 1/4" of insulation from each end.

(✓) Prepare the following wires:

- | | |
|-------------|------------|
| 1-1/2" gray | 2-1/2" red |
| 3-1/2" gray | 4" red |
| 1" red | 1-1/2" red |
| 1-1/2" red | 6" red |
| 2" gray | |

- (✓) Connect a 1-1/2" gray wire from section B lug 2 (S-2) to section C lug 2 (NS).
- (✓) Connect a 3/4" bare wire from section C lug 2 (S-2) to section D lug 3 (NS).
- (✓) Connect one end of the 3-1/2" gray wire to section D lug 3 (S-2). The other end will be connected later.

- (✓) Connect a 1-1/2" orange wire from section A lug 6 (NS) to section B lug 6 (NS).
- (✓) Connect a 1-1/2" orange wire from section B lug 6 (S-2) to section C lug 6 (NS).
- (✓) Connect one end of a 7" gray wire to section C lug 6 (S-2). The other end of this wire will be connected later.
- (✓) Connect a 1-1/2" gray wire from section C lug 3 (NS) to section D lug 6 (S-1).
- (✓) Connect a 4-3/4" gray wire to section C lug 3 (S-2). The other end of this wire will be connected later.
- (✓) Connect one end of a 9" gray wire to section B lug 3 (NS). The other end of this wire will be connected later.
- (✓) Connect one end of a 4" gray wire to section E lug 2 (NS). The other end of this wire will be connected later.

Set this switch assembly aside until it is called for in a step.

Refer to Pictorial 12-9 (Illustration Booklet, Page 8) and prewire the remaining pushbutton switch as follows:

- () Insert a 1-3/4" small bare wire through lugs 3 and 4 of switch sections A, B, and C. DO NOT solder lug 3 of section A. Solder the other five connections. Trim off any excess wire between sections C and D.
- () Prepare the following solid wires:

3-3/4" gray	1" gray
1-3/4" gray	1" gray
2" gray	10" gray
5-1/2" red	6-1/2" gray
4" gray	8" gray
10" gray	
- () Connect one end of the 3-3/4" gray wire to section A lug 3 (S-2).
- () Remove an additional 1/4" of insulation from one end of the 1-3/4" gray wire (total 1/2"). Push this end of the wire through section B lug 5 (S-2) to section A lug 6 (S-1). Connect the other end of the wire to section C lug 5 (NS).
- () Connect the 2" gray wire from section D lug 5 (NS) to section F lug 5 (NS).
- () R13: Cut both leads of a 180 Ω , 1/4-watt resistor (brown-gray-brown) to 1/2". Then connect the resistor from section C lug 5 (S-2) to section D lug 5 (S-2).
- () Connect one end of the 5-1/2" red wire to section F lug 2 (NS).
- () Remove an additional 1/4" of insulation from one end of the 4" gray wire (total 1/2"). Push this wire through lug 5 of section F (S-2) to lug 4 of section E (S-1).
- () Connect one end of the 10" gray wire to section D lug 2 (S-1).
- () Connect a 1" gray wire from section E lug 1 (S-1) to section E lug 6 (NS).
- () Connect a 1" gray wire from section E lug 2 (S-1) to section E lug 5 (NS).
- () Connect one end of a 10" gray wire to section E lug 5 (S-2).
- () Connect one end of a 6-1/2" gray wire to section E lug 3 (S-1).
- () Connect one end of an 8" gray wire to section E lug 6 (S-2).

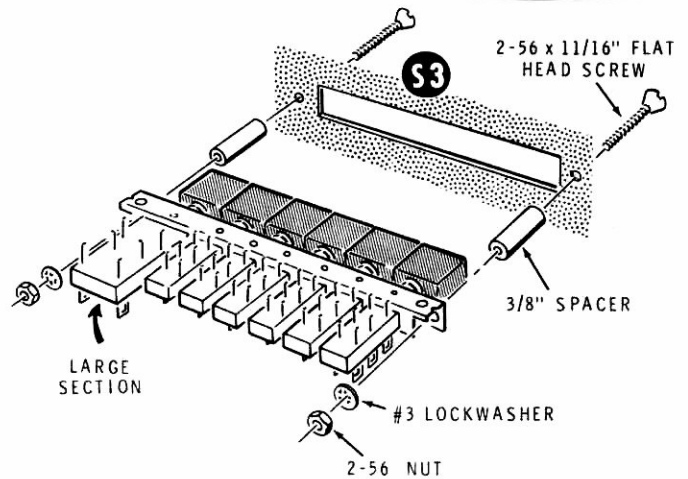

Detail 12-10A

Switches and Controls

Refer to Pictorial 12-10 (Illustration Booklet, Page 8) for the following steps.

NOTE: The plastic nut starter can be shortened for use in the following step. Cut it in the middle so both halves will still be useful.

- () S3: Select the prewired switch assembly which has one section larger than the other five sections. Then refer to Detail 12-10A and mount this switch at S3 on the chassis lip. Be sure the wired side of the switch is positioned down (toward the large chassis cutout). Use a 3/8" spacer, a 2-56 x 11/16" flat head screw, a 2-56 nut and a #3 lockwasher at each mounting hole.
- () S2: Mount the other prewired switch in the same manner at S2 on the chassis lip.
- () Check the action of the pushbuttons on the two ends of each switch. Loosen the hardware, if necessary, and readjust the switch position to eliminate any binding of the switch against the spacers.
- () Refer to Detail 12-10B and place a control solder lug and a control nut on a 10 k Ω control (#10-31). Form the solder lug so it touches lug 1 of the control. Solder the two lugs together. Then remove the control nut.

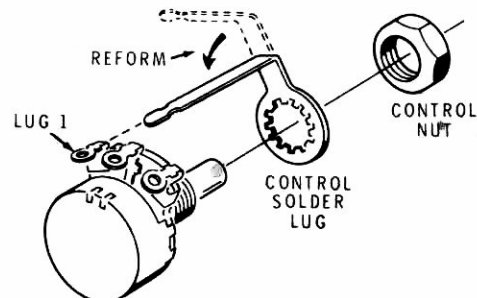

Detail 12-10B

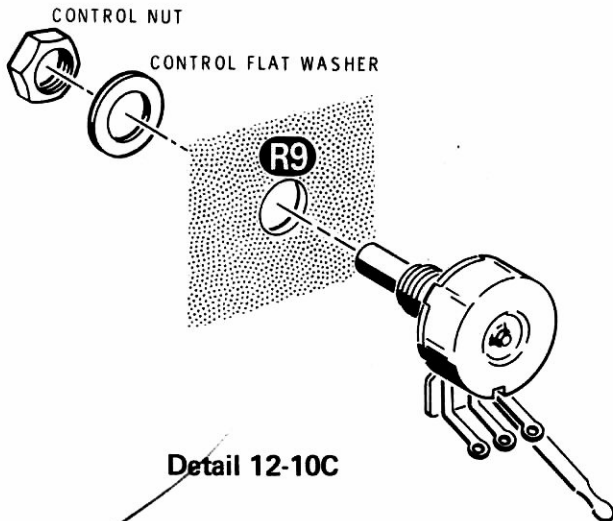

Detail 12-10C

- () R9: Refer to Detail 12-10C and mount the 10 kΩ control at R9 on the chassis lip. Use a control flat washer and a control nut. Position the lugs so they point down.

Refer to Detail 12-10D for the following steps.

- () Mount a control solder lug on the 10 kΩ/6 kΩ dual control (#12-113). Position the solder lug near lugs 1 and 4 of the control. Secure it temporarily with a control nut.
- () R16: Connect a 5600 Ω resistor (green-blue-red) from lug 3 (S-1) through lug 4 (S-2) to the solder lug (NS).
- () R17: Cut one lead of a 5600 Ω resistor (green-blue-red) to a 1" and the other lead to 3/8". Place a 3/4" length of small sleeving on the 1" lead. Then connect this lead to lug 1 (S-1). Connect the other resistor lead to lug 6 (NS).
- () Remove the control nut.

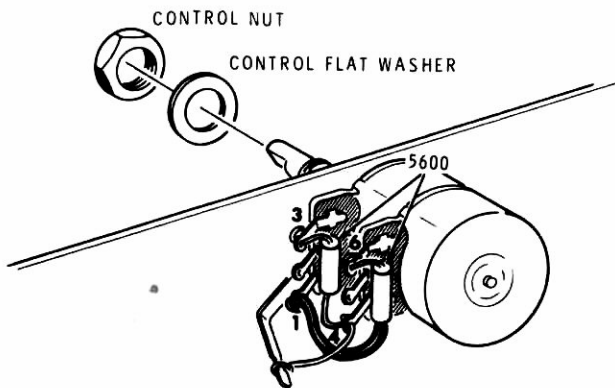

Detail 12-10D

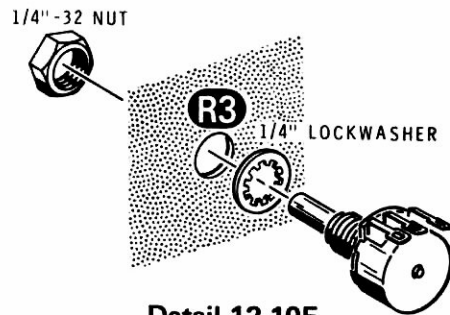

Detail 12-10E

- () R15: Mount the prepared 10 kΩ/6 kΩ dual control at R15 on the chassis lip. Use a control flat washer and a control nut. Position the control lugs as shown in the Pictorial.

Refer to Detail 12-10E for the next two steps.

- () R3: Mount a 100 kΩ control (#10-995) at R3 in the chassis lip with the lugs pointing up. Use a 1/4"-32 nut and a 1/4" lockwasher.
- () R1: Mount a 100 kΩ control (#10-995) at R1 on the chassis lip with the lugs pointing up. Use a 1/4"-32 nut and a 1/4" lockwasher.
- () R2: Refer to Detail 12-10F and mount the 200 kΩ/1500 Ω dual control (#12-138) at R2 on the chassis lip. Use a control solder lug, a control flat washer, and a control nut. The control lugs should point down, with the control solder lug near lug 1 as shown in the Pictorial. Bend the solder lug up so it does not project below the bottom edge of the chassis.

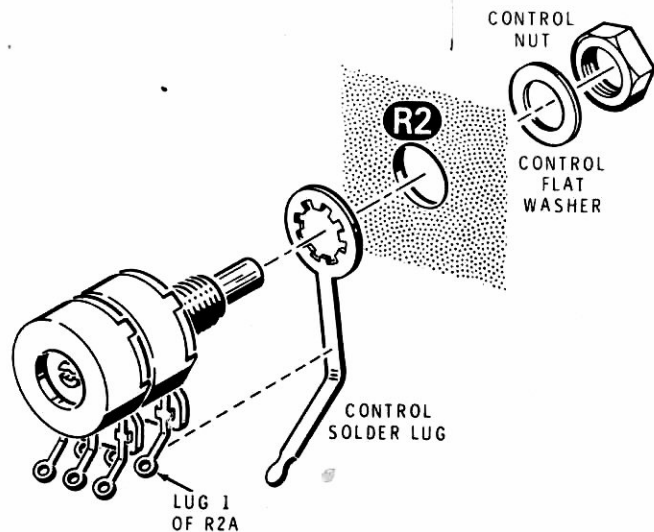

Detail 12-10F

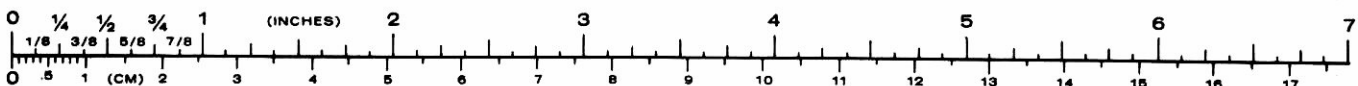

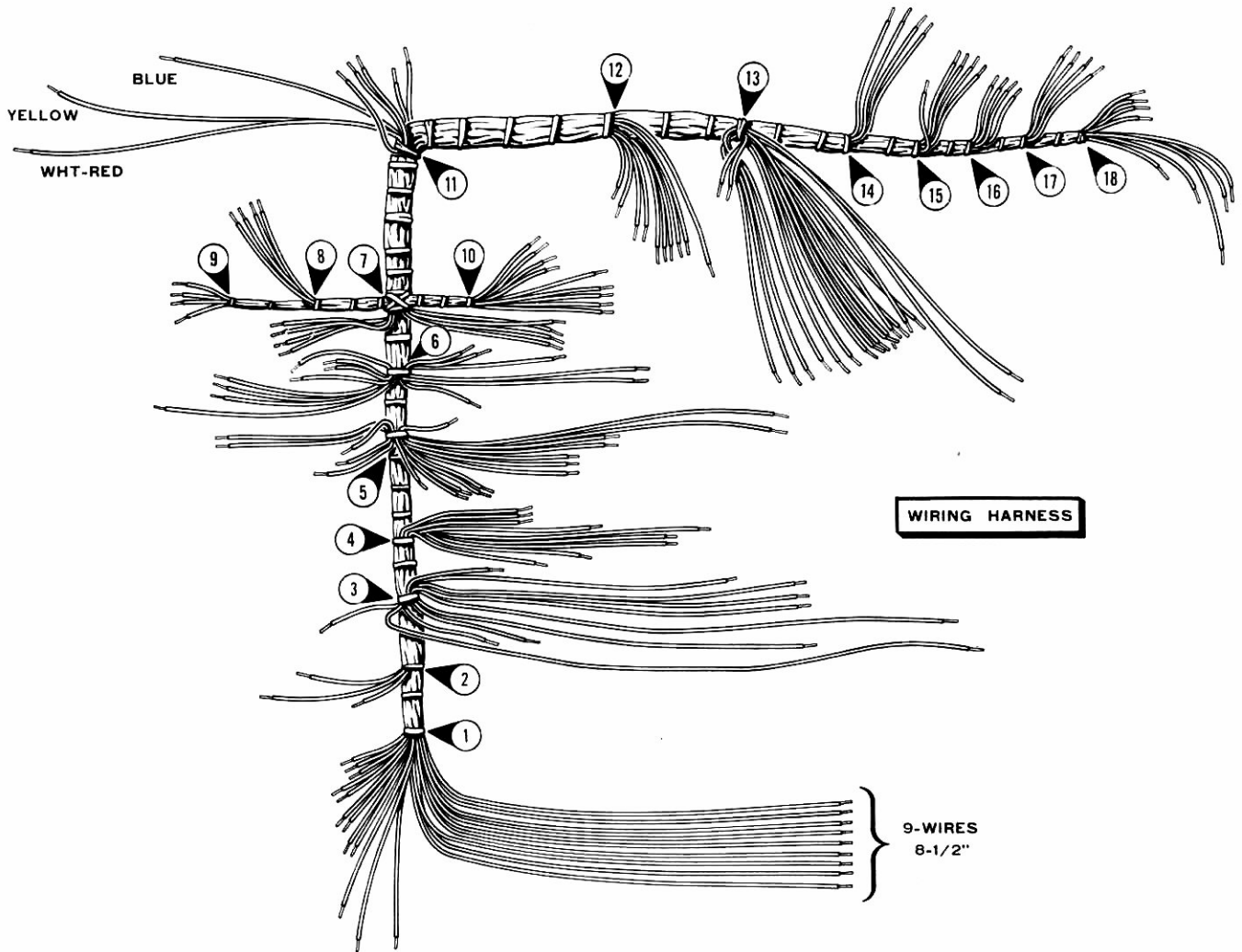

PICTORIAL 12-11

WIRING HARNESS

NOTES:

1. The locations where one or more wires leave the wiring harness are called "breakouts," abbreviated BO. Each BO has a number, as shown in Pictorial 12-11.
2. Harness wires are identified by length and color. Wires may be a solid color, or they may be white with one or more colored stripes (such as white-red or white-brown-brown). Be very careful when you select the harness wires as, for example, it is very easy to confuse white-yellow with white-yellow-yellow.
3. Identify as BO#1 the end of the wiring harness which has 21 wires, nine of which are 8-1/2" long. The other end of the wiring harness is BO#18.

NOTE: In the following steps you will install 26 wire connectors on a group of harness wires as shown in Detail 12-11A. Shorten each bare wire end to 1/4" before installing a connector.

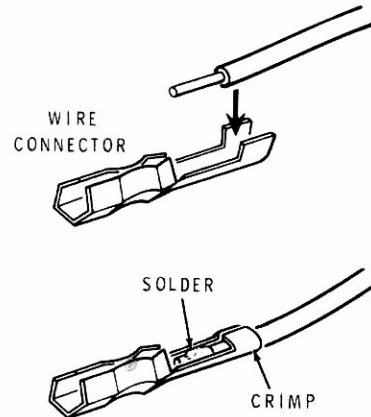

Detail 12-11A

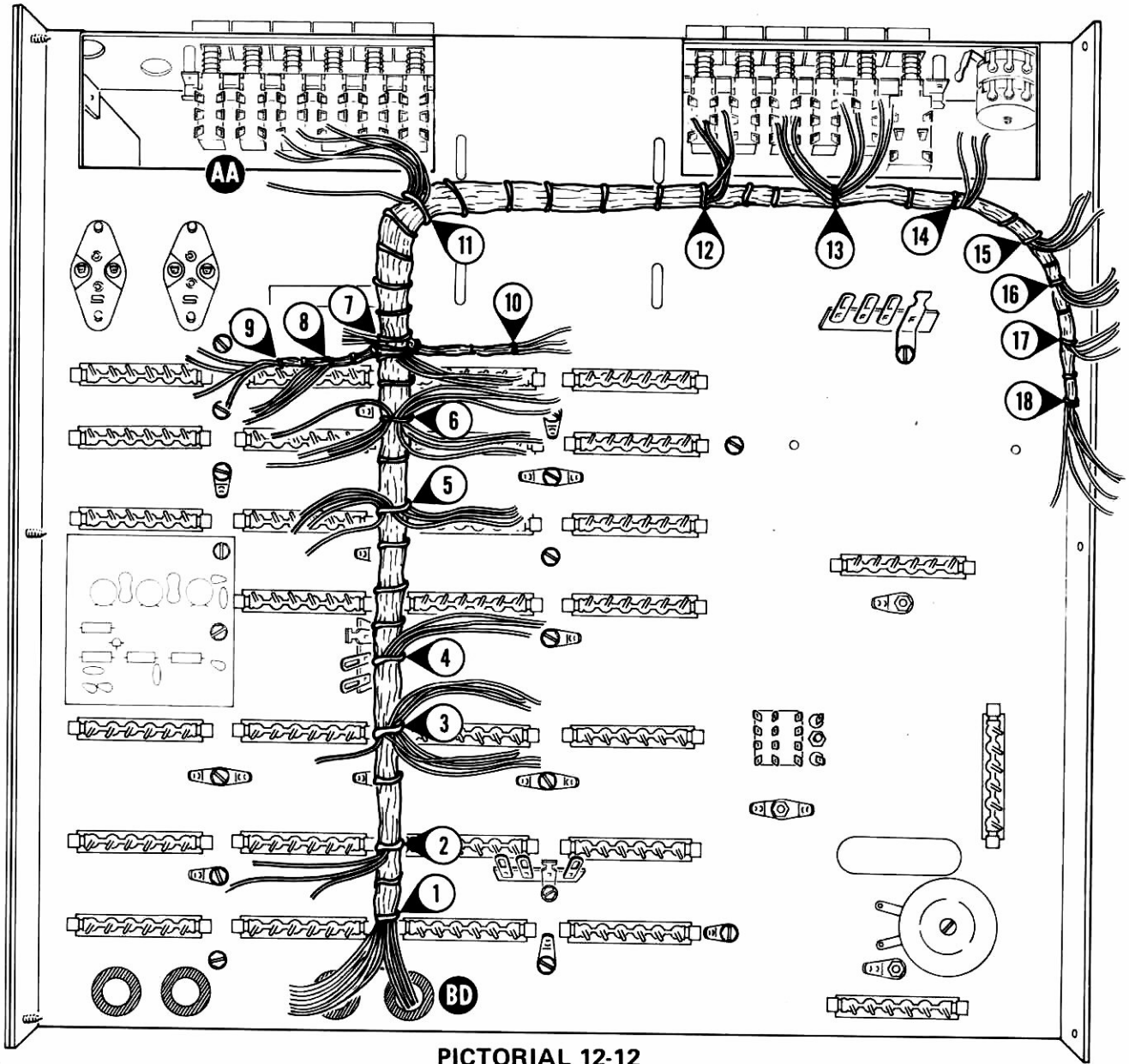

PICTORIAL 12-12

Install wire connectors (#432-120) on harness wires as follows:

- () BO#18: 9 wires.
- () BO#17: 4 wires.
- () BO#16: 4 wires.
- () BO#15: 5 wires.
- () BO#14: 4 wires.

(✓) Refer to Pictorial 12-12 and place the wiring harness against the bottom of the chassis with a right angle bend at BO#11. Position the harness so the wires from BO#11 are on the outside of the bend, as shown.

(✓) AT BO#1, group together all wires longer than the gray wire. Push the group of wires through grommet BD.

Refer to Pictorial 12-13 (Illustration Booklet, Page 8) for the following steps.

- () Connect the 10" gray wire coming from switch S2, section D, lug 2, to terminal strip BE lug 1 (NS).
- (✓) Connect the 6-1/2" gray wire coming from switch S2, section E, lug 3, to terminal B14 (S-1).
- (✓) Connect the 10" gray wire coming from switch S2, section E, lug 5, to terminal E9 (S-1/2).
- (✓) Connect the 8" gray wire coming from switch S2, section E, lug 6, to terminal strip AE lug 2 (NS).
- (✓) Connect the red wire coming from switch S3, section D, lug 2, to terminal strip BE lug 2 (NS).
- (✓) Connect the gray wire coming from switch S3, section E, lug 2, to terminal strip BE lug 3 (NS).
- (✓) Connect the lead at the banded end of a type 1N4149 diode (#56-56) to terminal strip BE lug 1 (S-2), and connect the other lead to lug 2 (NS).
- () Connect the lead at the banded end of a type 1N4149 diode (#56-56) to terminal strip BE lug 2 (S-3), and connect the other lead to lug 3 (NS).

NOTE: In the following steps you will connect the wiring harness. Each wire should be wound once around its terminal, but may be shortened as advisable. More than one Pictorial may be used to show the connections at one breakout. In most

cases, each wire will be soldered when it is connected. Use just enough solder to join the parts. Large globs of solder on a connection are unsightly and do not improve the connection.

As you connect wires between breakouts, not all of the wires will be connected in some cases. Connect only those wires you are instructed to connect in the steps.

BO# 11. Connect harness wires to S2 as follows:

- () White-black to section F lug 6 (S-1).
- (✓) Red to section F lug 2 (S-2).
- () White to section D lug 4 (S-1).
- (✓) White-green to section C lug 6 (S-1).
- (✓) White-red to section C lug 2 (S-1).
- () Violet to section B lug 6 (S-1).
- (✓) Push the blue and yellow wires down through chassis cutout AA. They will be connected later.

BO# 12. Connect harness wires to S3 as follows:

- () Red to section C lug 5 (S-3).
- (✓) Orange to section A lug 6 (S-2).
- (✓) Brown to section E lug 2 (S-3).
- () White-black to section E lug 5 (S-1).

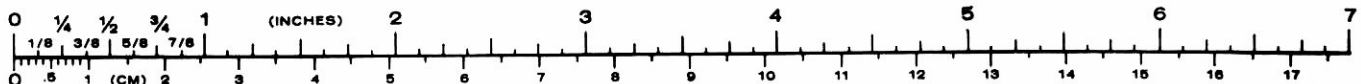

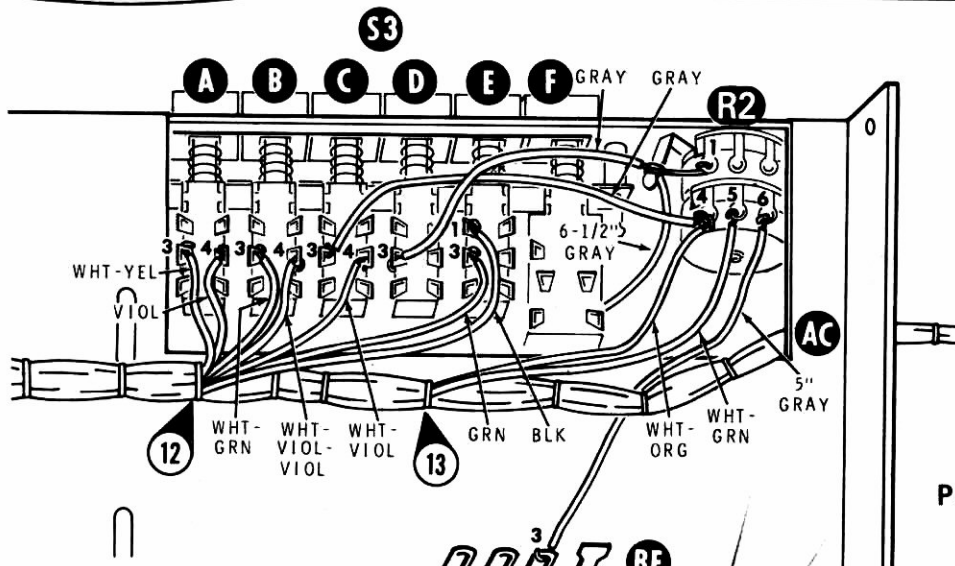

PICTORIAL 12-14

Refer to Pictorial 12-14 for the following steps.

BO#12. Connect harness wires to S3 as follows:

- (✓) White-yellow to section A lug 3 (S-1).
- (✓) Violet to section A lug 4 (S-1).
- (✓) White-green to section B lug 3 (S-2).
- (✓) White-violet-violet to section B lug 4 (S-1). Be sure there are two violet stripes.
- (✓) White-violet to section C lug 4 (S-1).
- (✓) Green to section E lug 3 (S-1).
- (✓) Black to section E lug 1 (S-1).

BO#13. Connect harness wires as follows:

- (✓) White-green to R2 lug 5 (S-1).
- (✓) Short white-orange to R2 lug 4 (NS).
- (✓) Connect the gray wire coming from S3, section C, lug 3 to R2 lug 4 (S-2).

Refer to Detail 12-14A for the following steps.

- (✓) Remove an additional 3/4" of insulation (total 1") from the end of the 3-1/2" gray wire coming from S3, section D, lug 3. Wrap this end around the control solder lug at R2 (NS) and then connect the end to R2 lug 1 (NS). NOTE: Three coaxial cable shield wires will be connected later to lug 1.

(✓) Prepare gray wires as follows:

- (✓) 5" 6-1/2"
- (✓) Connect the 5" gray wire from control R2 lug 6 (S-1) to terminal strip BE lug 3 (NS).
- (✓) Remove an additional 1/4" of insulation (total 1/2") from one end of the prepared 6-1/2" gray wire. Connect this end of the 6-1/2" gray wire to the control solder lug (S-3). Push the other end up through chassis cutout AC. It will be connected later.
- (✓) Push all remaining wires at this end of the wiring harness up through chassis cutout AC.

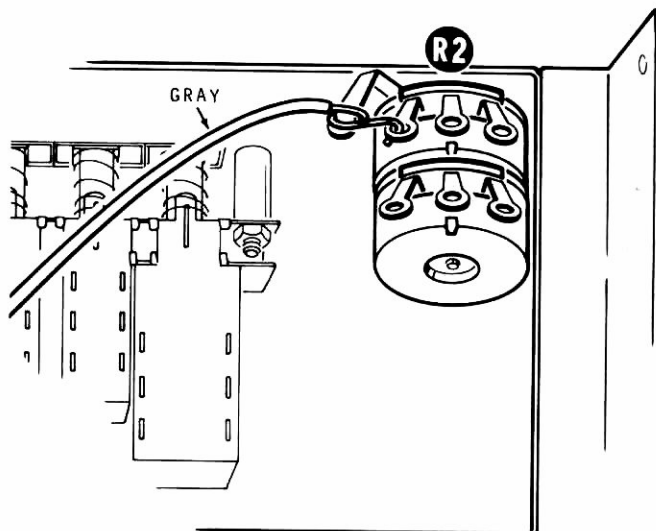

Detail 12-14A

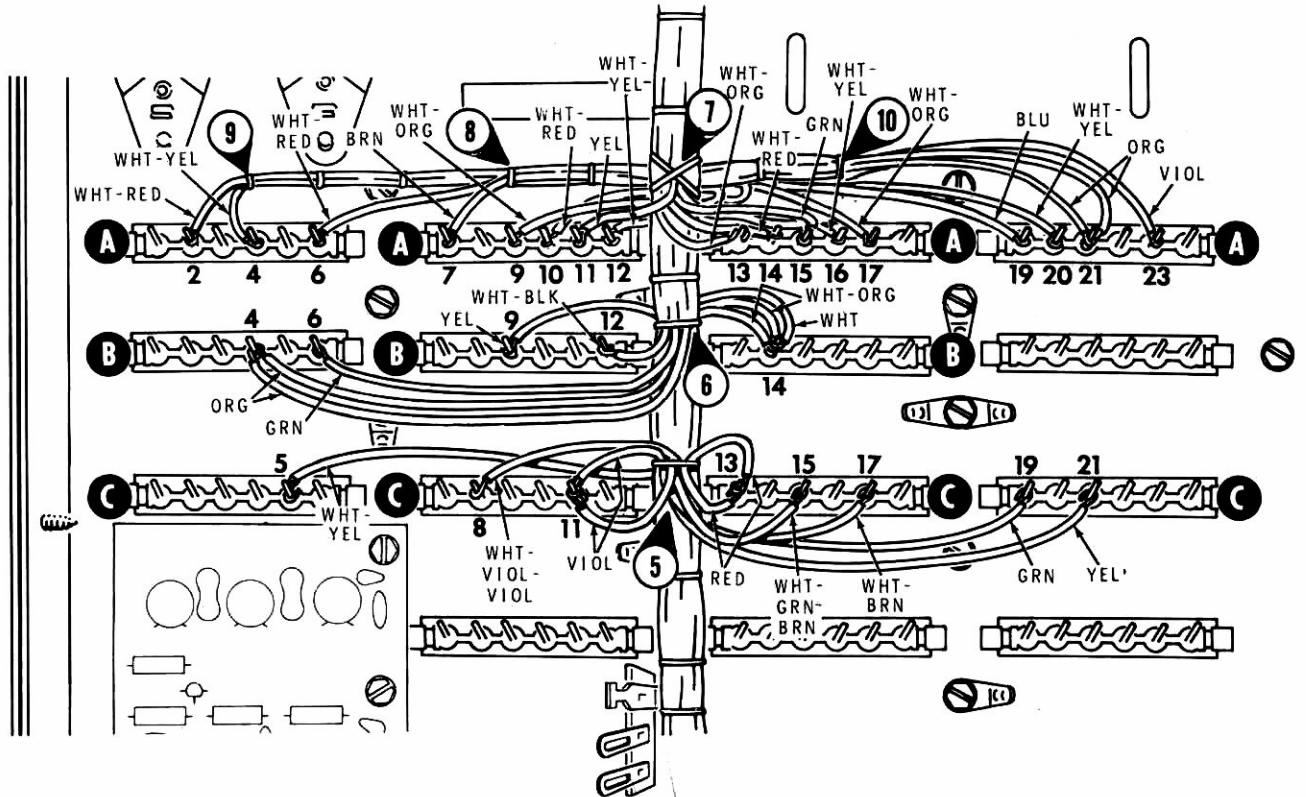

PICTORIAL 12-15

Refer to Pictorial 12-15 for the following steps.

BO#7. Separate the wires into a group of 1-1/2" wires and a group of 2-1/2" wires. Then connect the wires as follows:

- (✓) Short white-yellow to A16 (S-1).
- (✓) Yellow to A11 (S-1).
- (✓) Short white-red to A14 (S-1).
- (✓) Short white-orange to A13 (S-1).
- (✓) Long white-orange to A9 (S-1).
- (✓) Long white-red to A10 (S-1).

- (✓) Green to A15 (S-1).
- (✓) Long white-yellow to A12 (S-1).

BO#8. Connect harness wires as follows:

- (✓) Brown to A7 (S-1).
- (✓) White-red to A6 (S-1).

BO#9. Connect harness wires as follows:

- (✓) White-yellow to A4 (S-1).
- (✓) White-red to A2 (S-1).

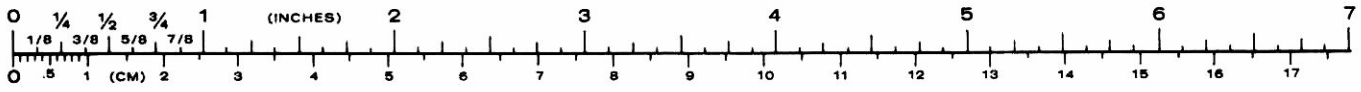

BO#10. Connect harness wires as follows:

- () White-orange to A17 (S-1).
- (✓) Blue to A19 (S-1).
- (✓) Orange to A21 (NS).
- (✓) Orange to A21 (S-2).
- (✓) Violet to A23 (S-1).

BO#6. Connect harness wires as follows:

- (✓) White-black to B12 (S-1).
- (✓) Yellow to B9 (S-1).
- (✓) Short white to B14 (S-1/2).
- (✓) Green to B6 (S-1/3).
- (✓) Orange to B4 (NS).
- () Orange to B4 (S-2).
- () White-orange to B14 (NS).
- () White-orange to B14 (S-2/4).

BO#5. Connect wires as follows:

- () Violet to C11 (NS).
- (✓) Violet to C11 (S-2).
- () Red to C13 (NS).
- () Red to C13 (S-2/3).
- (✓) White-green-brown to C15 (S-1/2).
- (✓) White-brown (not white-brown-brown) to C17 (S-1/2).
- (✓) Green to C19 (S-1/2).
- (✓) Yellow to C21 (S-1/2).
- (✓) White-violet-violet to C8 (S-1/2).
- (✓) White-yellow to C5 (S-1).

Refer to Pictorial 12-16 (Illustration Booklet, Page 9) for the following steps.

BO#4. Connect harness wires as follows:

- (✓) White-green-brown to D7 (S-1/2).
- (✓) White-brown to D9 (S-1/2).
- (✓) Green to D11 (S-1/2).
- (✓) White-blue to D13 (S-1/2).
- (✓) Gray to D15 (S-1/2).

BO#3. Connect harness wires as follows:

- (✓) Short white-orange to E17 (S-1/2).
- (✓) White-yellow to E15 (S-1).
- (✓) White-violet-violet to E16 (NS).
- (✓) White-green to E16 (S-2).

BO#2. Connect harness wires as follows:

- (✓) White-gray-gray to F9 (S-1).
- (✓) White-red-red to F10 (S-1).
- (✓) Violet to F5 (S-1).
- (✓) Yellow to F8 (S-1).

BO#1. Connect harness wires as follows:

- (✓) White-green-brown to G11 (S-1).
- (✓) White-brown (not white-brown-brown) to G9 (S-1).
- () Green to G7 (S-1).
- (✓) Red to G14 (S-1/2).
- (✓) White-violet-violet to G17 (S-1).
- () Long yellow to G20 (S-1).

Refer to Pictorial 12-17 (Illustration Booklet, Page 9) for the following steps.

BO#8. Connect harness wires as follows:

- (✓) White-yellow to A8 (S-1).
- (✓) White-orange to A5 (S-1).

BO#9. Connect harness wires as follows:

- (✓) Black to A3 (S-1).
- (✓) White-orange to A1 (S-1).

BO#10. Connect harness wires as follows:

- (✓) White-red to A18 (S-1).
- (✓) White-yellow to A20 (S-1).
- (✓) White-violet-violet to A22 (S-1).
- (✓) White-violet to A24 (S-1).

BO#6. Connect harness wires as follows:

- (✓) Black to B10 (S-1).
- (✓) Blue to B8 (S-1).
- (✓) Red to B1 (S-1/2).
- (✓) Brown to B23 (NS).
- (✓) Brown to B23 (S-2).
- (✓) Long white to B24 (S-1).

BO#5. Connect harness wires as follows:

- (✓) Brown to C18 (S-1/2).
- (✓) White-brown-brown to C16 (S-1/2).
- (✓) Blue to C20 (S-1/2).
- (✓) Gray to C22 (S-1/2).
- (✓) Short white-green to C6 (S-1).
- (✓) White-orange to C4 (S-1).

BO#4. Connect harness wires as follows:

- (✓) White-brown-brown to D8 (S-1/2).
- (✓) Brown to D10 (S-1/2).
- (✓) White-violet-violet to D12 (S-1/2).
- (✓) Yellow to D14 (S-1/2).

BO#1. Connect harness wires as follows:

- (✓) White-brown-brown to G10 (S-1).
- (✓) Brown to G8 (S-1).
- (✓) Yellow to G15 (S-1/2).
- (✓) White-blue to G18 (S-1).
- (✓) Gray to G21 (S-1).
- (✓) White-red wire to terminal strip BP lug 4 (NS).

Refer to Pictorial 12-18 for the following steps.

BO#5. Connect harness wires as follows:

- (✓) White-green to K6 (S-1).
- (✓) White to K4 (S-1).

NOTE: When you connect harness wires to the relay in the following steps, push the wire through the lug opening, then up and over the top of the lug and down along the flat side. Shorten the bare end of the wire as necessary to keep it from touching another lug. See Detail 12-18A.

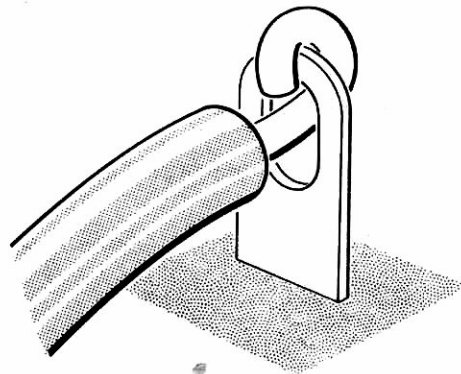

Detail 12-18A

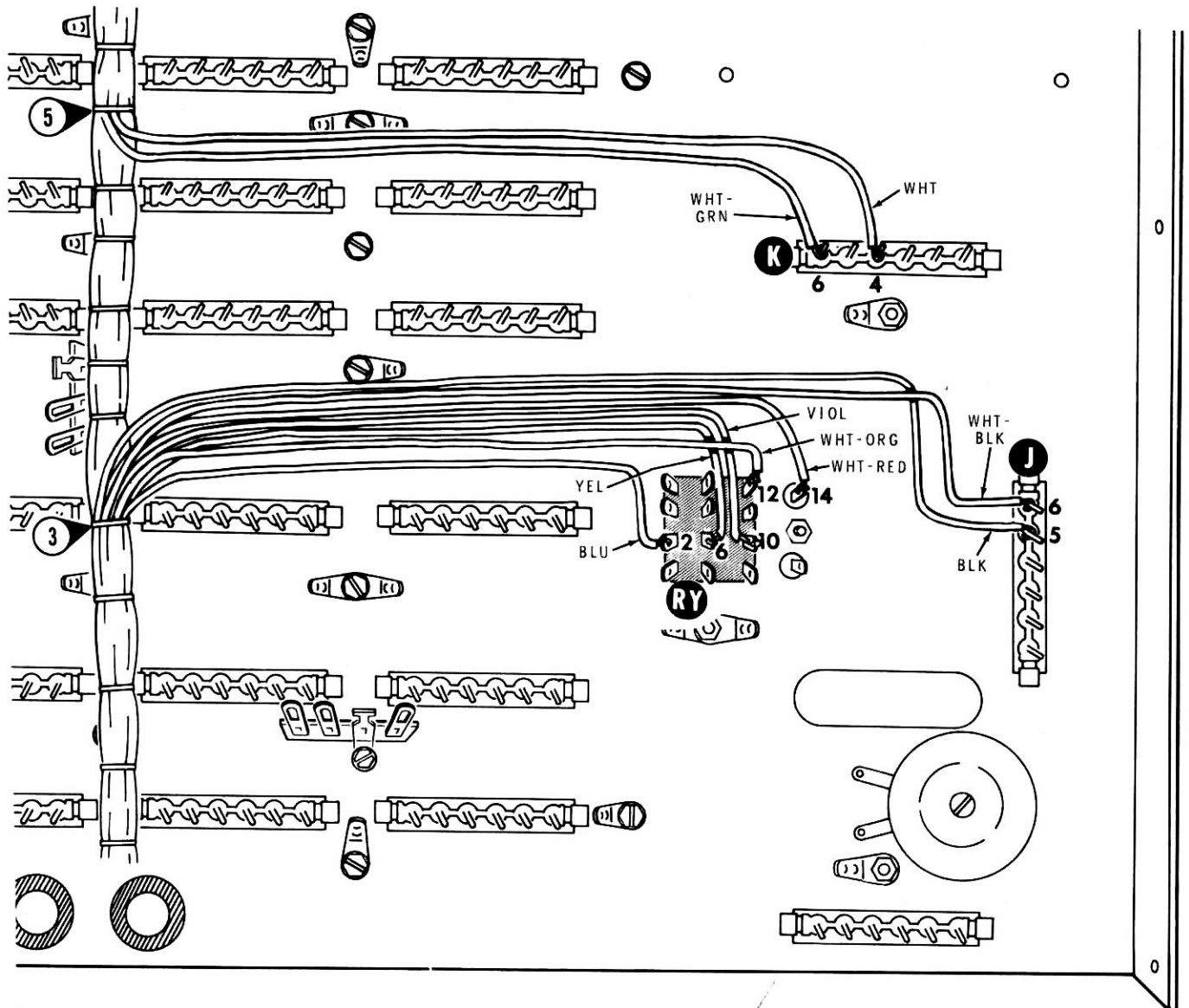

PICTORIAL 12-18

BO#3. Connect harness wires as follows:

() Blue to relay RY lug 2 (S-1).

() Yellow to relay RY lug 6 (S-1).

() Violet to relay RY lug 10 (NS).

() Long white-orange to relay RY lug 12 (S-1).

() White-red to relay RY lug 14 (S-2).

() Black to J5 (S-1).

() White-black to J6 (S-1).

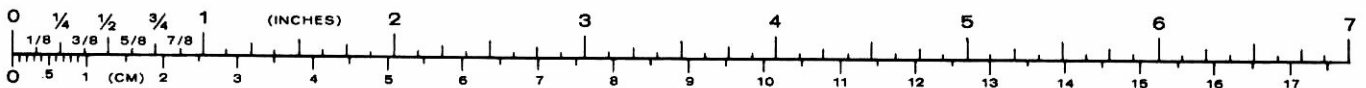

PARTS AND CABLES

Refer to Pictorial 12-19 (Illustration Booklet, Page 10) for the following steps.

- () Cut a 1-1/2" small bare wire. Then form a small hook in one end of the wire.
- () Refer to the inset drawing on the Pictorial and form a small hook in one end of a 16 k Ω , 1/2-watt resistor (brown-blue-orange). Then connect the hook on the resistor lead to the hook on the 1-1/2" bare wire and solder the connection.
- () R12: Place a 1/2" length of small black sleeving on one lead, and a 1-3/4" length of sleeving on the other lead of the prepared 16 k Ω resistor. Then connect the resistor from the collector (C) of Q1 (S-2) to switch S2, section A, lug 5 (S-1).
- () Place a 3/4" length of small black sleeving on one lead, and a 1" length of small black sleeving on the other lead of a .15 Ω , 2-watt (brown-green-silver-gold) resistor and a .33 Ω , 2-watt (orange-orange-silver-gold) resistor.

NOTE: In each of the following two steps, do not use so much solder that it runs down the transistor lug.

- () R6: Connect the prepared .33 Ω resistor from lug E of transistor Q2 (S-1) to terminal B1 (S-1/3). Connect the lead with the 1" sleeving to B1.
- () R5: Connect the prepared .15 Ω resistor from lug E of transistor Q1 (S-1) to terminal B4 (S-1/3). Connect the lead with the 1" sleeving to B4.
- () C14: Connect the positive (+) lead of a 5 μ F vertical electrolytic to terminal strip BE lug 3 (S-4). Connect the other lead to lug 4 (S-1).
- () C15: Connect a .001 μ F disc capacitor between relay RY terminals 10 (S-2) and 13 (S-3).
- () C16: Connect a .1 μ F Mylar capacitor from terminal C2 (S-1/2) to terminal C4 (S-1/2).
- () C17: Connect a .01 μ F disc capacitor from terminal C5 (S-1/2) to the upper hole at solder lug AH (NS).
- () C4: Connect a .1 μ F Mylar capacitor from terminal C6 (S-1/2) to the upper hole of solder lug AH (S-3/5).
- () R18: Connect a 22 Ω , 1/2-watt (red-red-black) resistor from terminal D4 (S-1/2) to the upper hole of solder lug AL (S-1/3).

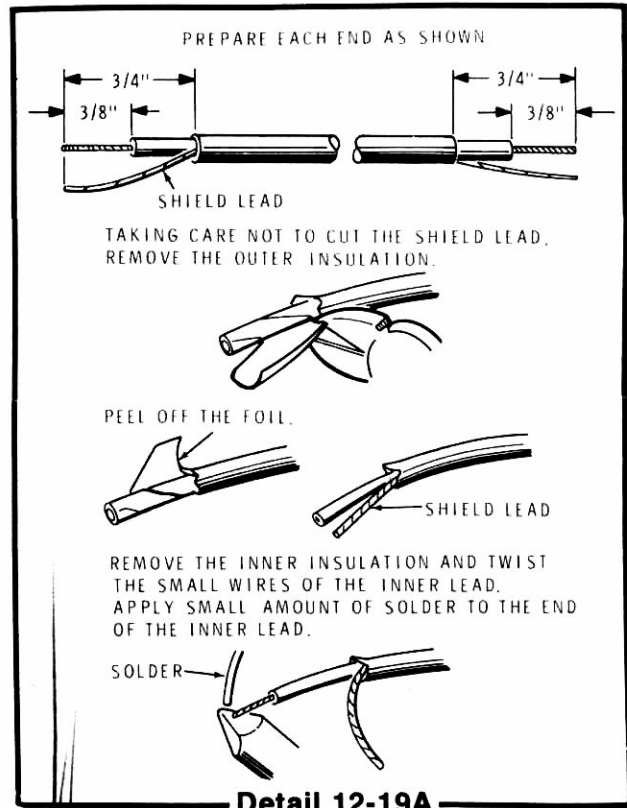

- () D4: Connect the banded end of a 1N4149 diode (#56-56) to terminal strip AE lug 3 (S-2). Connect the other diode lead to terminal strip AE lug 2 (S-2).
- () C19: Connect a .1 μ F Mylar capacitor from terminal D15 (S-1/3) to the upper hole of solder lug AN (S-1/2).
- () C18: Connect a .01 μ F disc capacitor from terminal F8 (S-1/2) to the upper hole of solder lug AP (S-1/2).
- () R21: Connect a 47 Ω , 1/2-watt (yellow-violet-black) resistor from terminal G4 (S-1/2) to the upper hole of solder lug AT (NS).
- () C21: Connect a .1 μ F Mylar capacitor between terminals G19 (S-1/2) and G21 (S-1/2).

Refer to Detail 12-19A for the preparation of the shielded cables in the following steps. Cut each cable to length and then prepare each end as shown. Be very careful when you remove the outer insulation so you do not cut the inner insulation or shield wires.

- () Prepare shielded cables as follows. DO NOT use cable RG-58A/U. Cables are listed in the sequence in which they will be connected.

3-1/2"	3-3/4"	4-1/2"
5-1/4"	3-1/2"	2"
5-1/2"	2-1/4"	
7-3/4"	8-1/4"	

Connect the prepared shielded cables to chassis connector terminals as follows. The connections of the center conductors are designated first in each step, followed by the shield wires. Solder each wire as you connect it.

- () 3-1/2" from E1 to G1, with shield wires to E2 and G3.
- () 5-1/4" from D2 to G6, with shield wires to D3 and solder lug AT.
- () 5-1/2" from E12 to F1, with shield wires to F2 and solder lug AR.
- () 7-3/4" from C3 to E6, with shield wires to C2 and solder lug AY.
- () 3-3/4" from E19 to F14, with shield wires to F13 and solder lug AS.
- () 3-1/2" to F11 with shield wires to F12. The other end will be connected later.
- () 2-1/4" to G24 with shield wires to G23. The other end will be connected later.

NOTE: At this point three prepared cables remain. They will be connected later with the three cables which you will prepare in the two following steps.

- () Prepare ONE END ONLY of shielded cables as shown in Detail 12-19A.

18-1/4" 9-3/4" 9-1/4"

- () Refer to four-part Detail 12-19B (Illustration Booklet, Page 10) and install a phono plug on the other end of each of the shielded cables prepared in the preceding step. Be sure to use plug #438-46.
- () Connect one end of the 8-1/4" cable to H3 (NS) and the shield wires to H2 (S-1/2). The other end will be connected later.
- () Connect the 9-1/4" cable with phono plug to H3 (S-2) and the shield wires to solder lug BN (S-1/3). Push the other end of the cable up through chassis cutout BL.
- () Connect one end of the 4-1/2" cable to relay RY at lug 1 (NS) and the shield wires to solder lug BW (NS). The other end of this cable will be connected later.
- () Connect the end of the 9-3/4" cable with phono plug to relay RY at lug 1 (S-2) and the shield wires to solder lug BW (S-2). Push the other end of the cable through chassis cutout BL.

- () Connect the 2" cable from C10 (S-1) to D6 (S-1) and the shield wires to C9 (S-1/2) and D5 (S-1/2).
- () Connect the end of the 18-1/4" cable with phono plug to C10 (S-1/2) and the shield wires to C9 (S-1/3). Push the other end of this cable through chassis cutout AA.

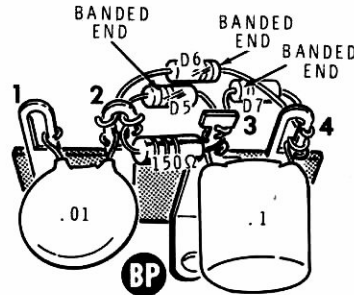

Detail 12-19C

Refer to Detail 12-19C for the next six steps.

- () D5: Cut each lead of a 1N191 diode (#56-26) to 1/2". Then connect the lead at the banded end of the diode to terminal strip BP lug 2 (NS). Connect the other diode lead to lug 3 (NS).
- () D7: Cut each lead of a GD510 diode (#56-89) to 1/2". Then connect the lead at the banded end of the diode to terminal strip BP lug 3 (NS). Connect the other diode lead to lug 4 (NS).
- () D6: Cut each lead of another 1N191 diode (#56-26) to 1/2". Then connect the lead at the banded end of the diode to terminal strip BP lug 4 (NS). Connect the other diode lead to lug 2 (NS).
- () C22: Cut each lead of a .01 μF disc capacitor to 1/2". Then connect the capacitor between terminal strip BP lugs 1 (NS) and 2 (NS).
- () C23: Cut each lead of a .1 μF Mylar capacitor to 1/2". Then connect the capacitor between terminal strip BP lugs 3 (NS) and 4 (S-4).
- () R21: Cut each lead of a 150 Ω, 1/2-watt (brown-green-brown) resistor to 1/2". Then connect the resistor between terminal strip BP lugs 2 (S-4) and 3 (S-4).

NOTE: Another wire will be connected to lug 1 of the terminal strip during the "Tests and Adjustments."

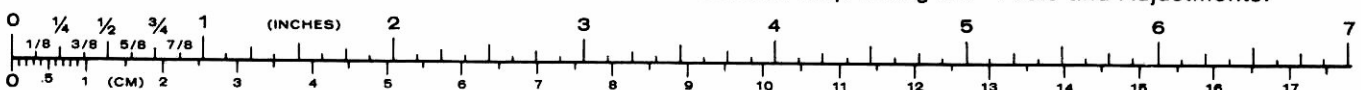

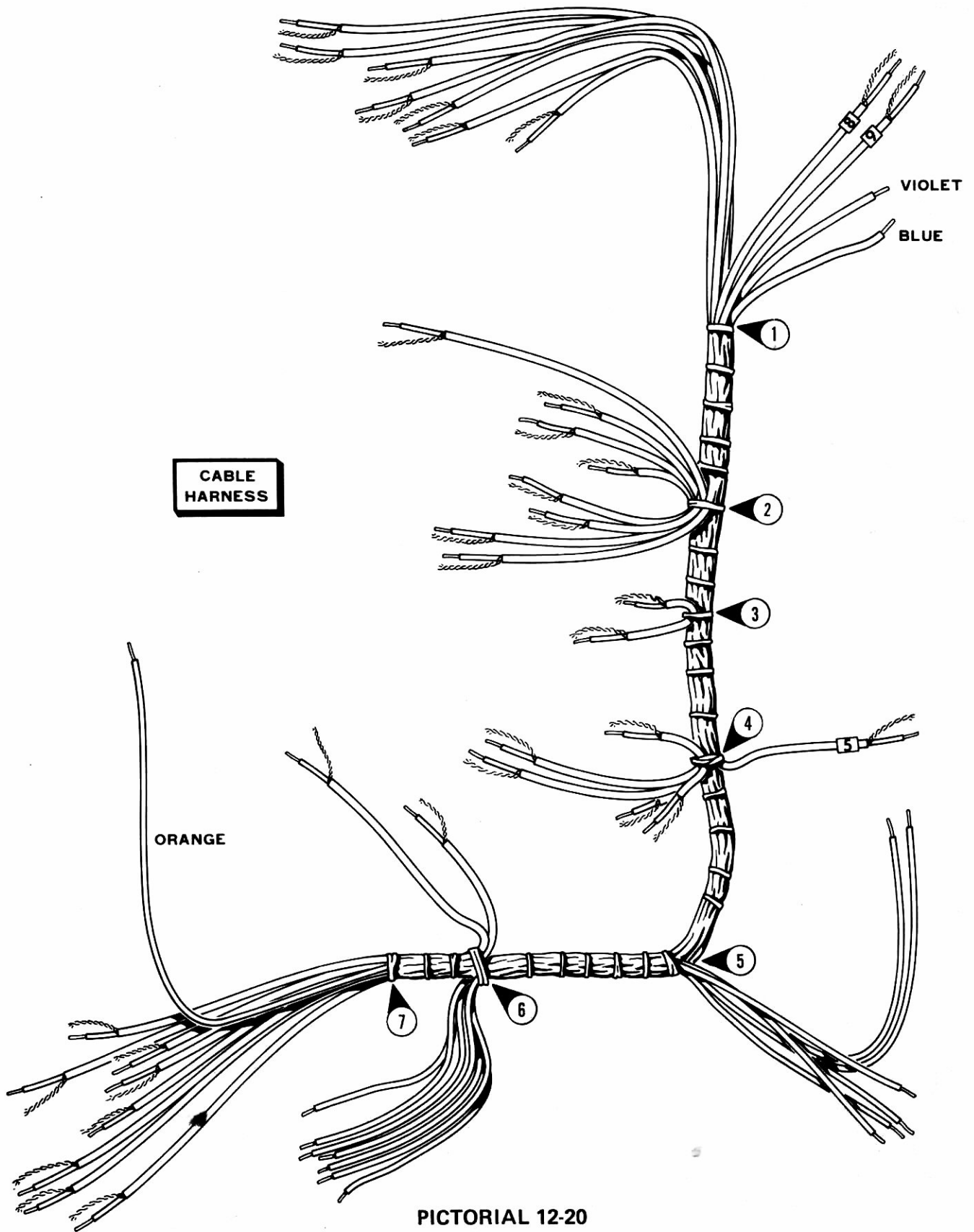

CABLE HARNESS

VIOLET
BLUE

ORANGE

PICTORIAL 12-20

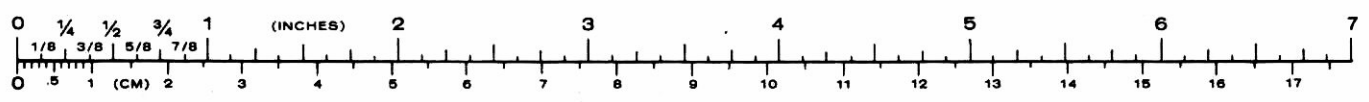

CABLE HARNESS

- () Refer to Pictorial 12-20 and form the cable harness as shown. Note that each breakout has a number (as in the wiring harness) and that each shielded cable has an individual number label. BO#1 is at the end of the harness which has the violet and the blue wires.

Refer to Pictorial 12-21 (Illustration Booklet, Page 11) for the following steps.

- () Place the cable harness against the bottom of the chassis as shown.
- () Push all the seven colored wires at BO#6 through grommet BC.
- () At BO#7 push shielded leads 3 and 10 through grommet BA, and leads 1, 2, 14, 15, 16, and 17 through grommet BB.
- () At BO#1, push shielded leads 1, 4, 6, 7, 10, 11, and 12 through chassis cutout AC (lead 6 is 11" long). Shielded leads 8 and 9 and the two colored wires are not pushed through the cutout.

BO#1. Connect some of the wires as follows:

- () Lead 8 to R2 lug 2 (S-1) and the shield wires to R2 lug 1 (NS). Use 5/8" of small sleeving on the shield wire.
- () Lead 9 to R2 lug 3 (NS) and the shield wires to R2 lug 1 (NS). Use 5/8" of small sleeving on the shield wire.

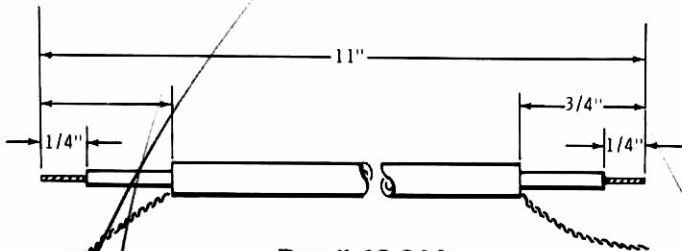

Detail 12-21A

- () Refer to Detail 12-21A and prepare an 11" shielded cable.
- () Connect one end of the prepared cable to R2 lug 3 (S-2) and the shield wires to R2 lug 1 (S-4). Use 5/8" of small sleeving on the shield wire. Push the other end of this cable through chassis cutout AC.
- () Refer to Detail 12-21B and twist lugs 3 and 4 of S3, section F, 1/4 turn so the holes in the lugs are aligned.
- () Remove insulation from the violet and the blue wires coming from BO#1 so each has 3/4" of bare wire exposed.

Connect the two colored wires to switch S3 section F as follows:

- () Push the violet wire through lug 3 (S-2) to lug 4 (S-1). It may be helpful to flatten the wire slightly so it will go through the switch lugs easily.
- () Push the blue wire through lug 5 (S-2) to lug 6 (S-1).

BO#2. Connect three of the leads as follows:

- () Lead 16 to B20 (S-1) and the shield wires to B22 (S-1/2).
- () Lead 12 to B18 (S-1) and the shield wires to solder lug AX (NS).
- () Lead 9 to B15 (S-1) and the shield wires to solder lug AX (NS).

BO#3. Connect the leads as follows:

- () Lead 5 to C24 (S-1) and the shield wires to C23 (S-1/2).
- () Lead 13 to E24 (S-1) and the shield wires to E22 (S-1/2).

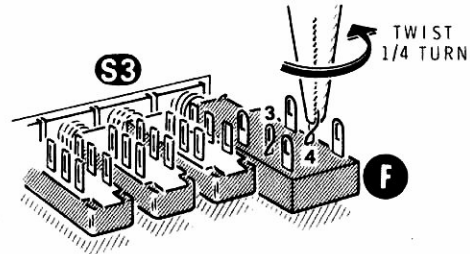

Detail 12-21B

BO#4. Connect three of the leads as follows:

- () Lead 2 to F21 (NS) and the shield wires to F23 (NS).
- () Lead 4 to F21 (S-2) and the shield wires to F23 (S-2/4).
- () Lead 7 to F16 (S-1) and the shield wires to solder lug AZ (NS).

BO#5. Connect the leads as follows:

- () Lead 17 to F15 (S-2) and the shield wires to F18 (S-1/2).
- () Lead 3 to G4 (S-1/3). Place a small ferrite bead on the shield wire. Then connect the shield wire to G3 (S-1/3).

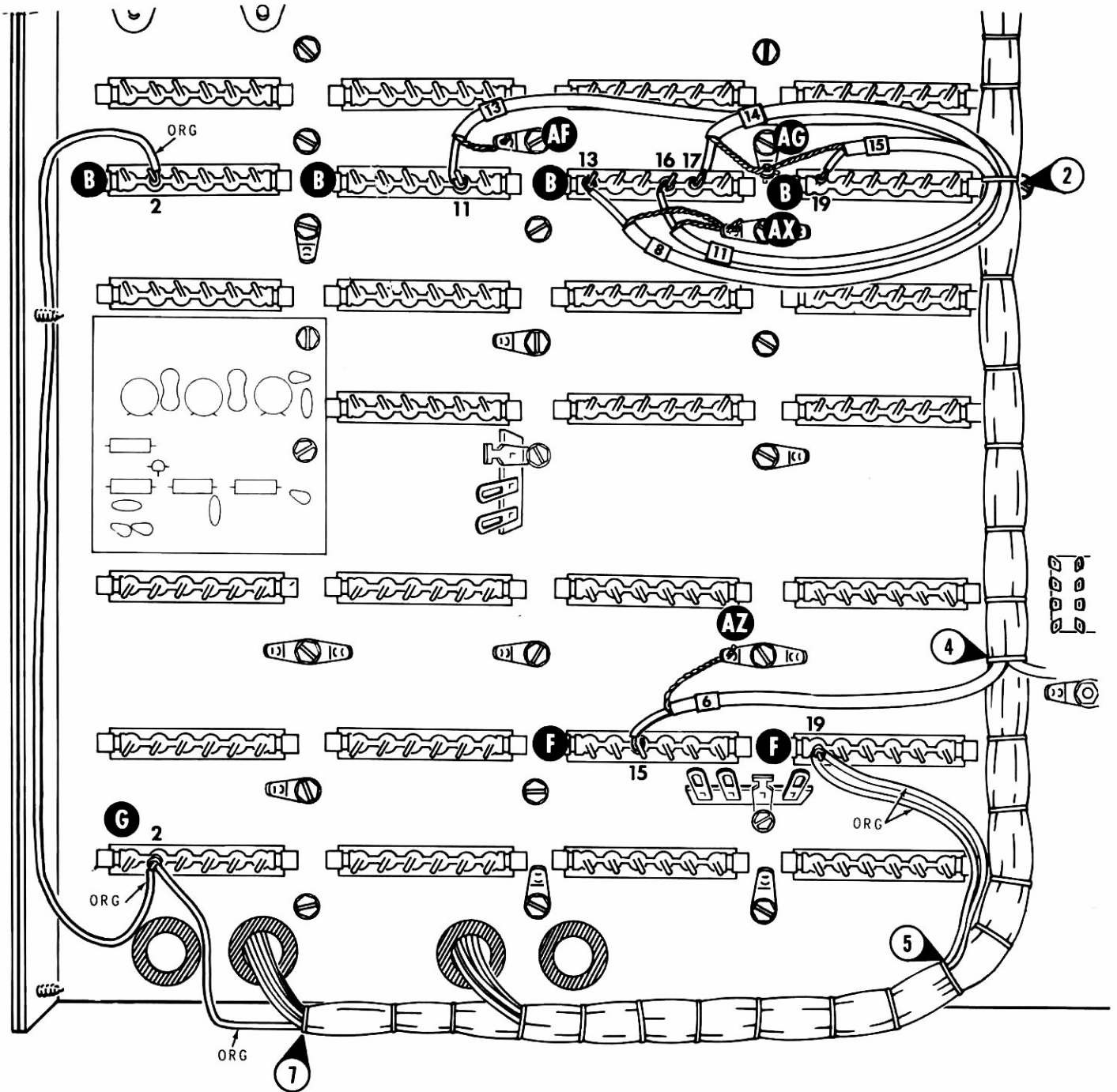

PICTORIAL 12-22



Refer to Pictorial 12-22 for the following steps.

BO#2. Connect leads as follows:

- (✓) Lead 15 to B19 (S-1) and the shield wires to solder lug AG (NS).
- (✓) Lead 14 to B17 (S-1) and the shield wires to solder lug AG (S-2).
- (✓) Lead 13 to B11 (S-1) and the shield wires to solder lug AF (S-1). Be careful, do not let the soldering iron touch other wires.
- (✓) Lead 11 to B16 (S-1) and the shield wires to solder lug AX (NS).
- () Lead 8 to B13 (S-1) and the shield wires to solder lug AX (S-4).

BO#4. Connect leads as follows:

- () Lead 6 to F15 (S-1/3) and the shield wires to solder lug AZ (S-2/4).

BO#5. Connect two of the leads as follows:

- () Either orange wire to terminal F19 (NS).
- () Remaining orange wire to terminal F19 (S-2/3).

BO#7.

- (✓) Cut the orange wire 2-1/2" from where it leaves the breakout. Save the cut off piece.

- () Prepare the free end of the orange wire coming from the harness; then connect it to terminal G2 (NS).
- (✓) Prepare the ends of the orange wire that were cut off the harness. Then connect the wire from terminal G2 (S-2) to terminal B2 (S-1/2). Route this wire as shown on the Pictorial.

Refer to Pictorial 12-23 for the following steps.

BO#5. Connect the wires as follows:

- (✓) Remove an additional 1/2" of insulation from one of the 4-3/4" red wires (total 7/8"). Wrap the bare end around terminals H5 (NS) and then around H6 (S-1/2).
- (✓) Wrap the bare end of another red wire around H5 (S-3).
- () Wrap the bare end of a red wire around terminal H6 (NS).
- (✓) Wrap the bare end of the remaining 5" red wire around H6 (S-2/4).
- (✓) Prepare a 12-1/2" stranded orange wire.
- (✓) Connect one end of the orange wire to terminal H1 (S-1/2). Push the other end of the wire through grommet BD.
- () Connect lead 5 from BO#4 to J2 (S-1) and the shield wires to J3 (S-1/2).

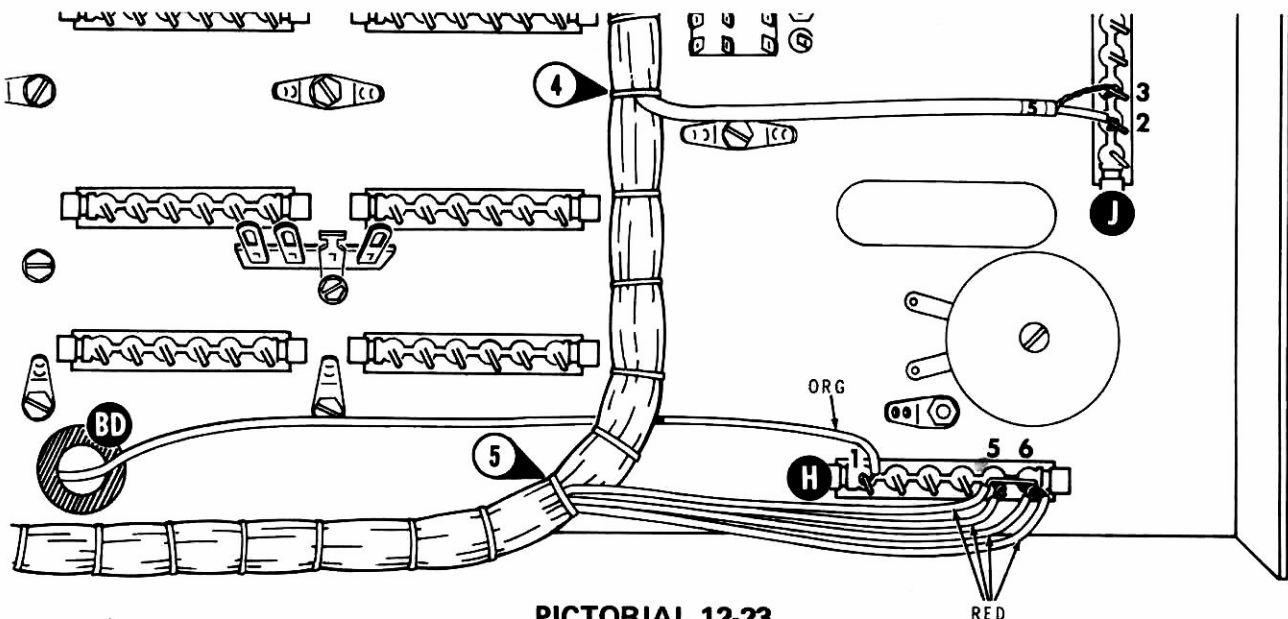

PICTORIAL 12-23

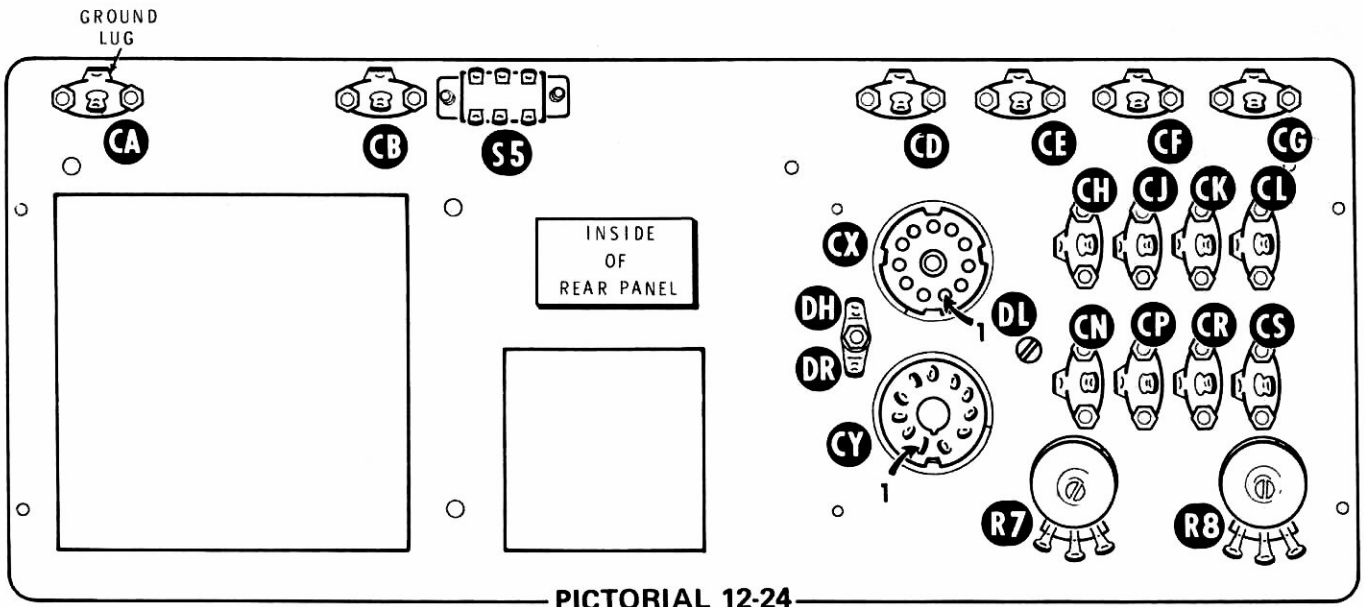

PICTORIAL 12-24

REAR PANEL

Refer to Pictorial 12-24 for the following steps.

NOTES:

1. Place a soft cloth on your work bench to prevent scratching the panel surface.
 2. Before you tighten the hardware in the following steps, center the socket in the panel opening by inserting a phono plug in the socket. Remove the plug after the hardware is tightened.
- () Refer to Detail 12-24A and install a phono socket at CA on the rear panel with 6-32 x 3/8" hardware. Use the plastic nut starter to hold and start nuts. Position the ground lug of the socket toward the panel edge.

() Similarly, install five phono sockets at the following locations. Use 6-32 x 3/8" hardware.



() Install eight phono sockets at the following locations. Use 6-32 x 3/8" hardware. Position the ground lugs toward holes CX and CY.

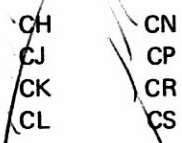

() S5. Refer to Detail 12-24B and install a DPDT slide switch at S5 on the rear panel. Use 6-32 x 3/8" screws.

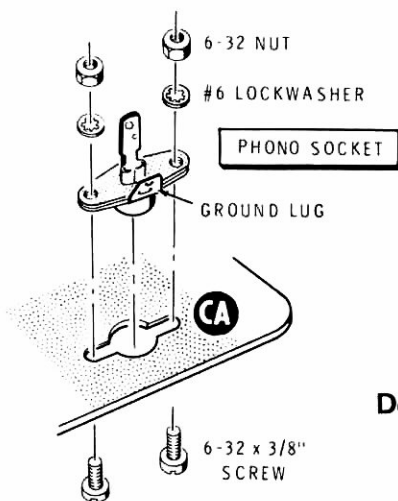

Detail 12-24A

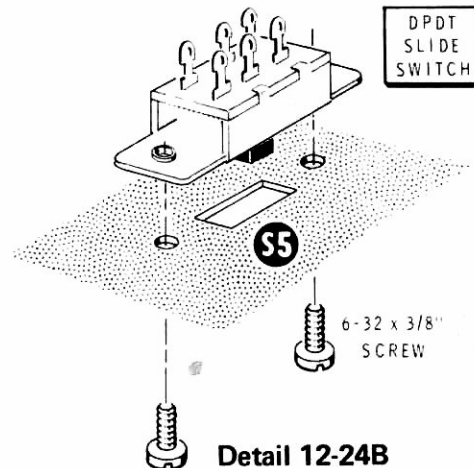

Detail 12-24B

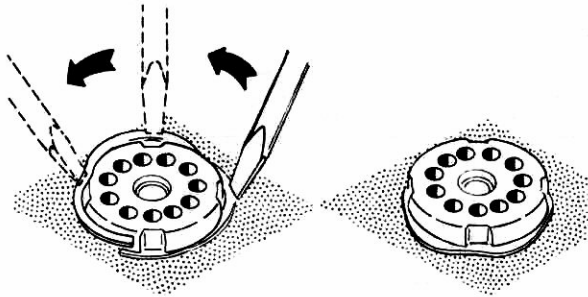

HOLD THE PLUG IN THE CHASSIS HOLE AND PLACE ONE END OF THE RING INTO THE GROOVE OF THE PLUG. USING A SCREWDRIVER, PRESS THE RING INTO THE GROOVE AROUND THE PLUG.

Detail 12-24C

- () Refer to Detail 12-24C and mount the 11-pin plug at CX using a retaining ring. Position pins 1 and 11 of the plug toward the letters ACC on the panel. The pin numbers are molded into the plug.
- () Similarly, mount an 11-pin socket at CY using a retaining ring. Position lugs 1 and 11 of the socket toward the letters ACC on the panel.

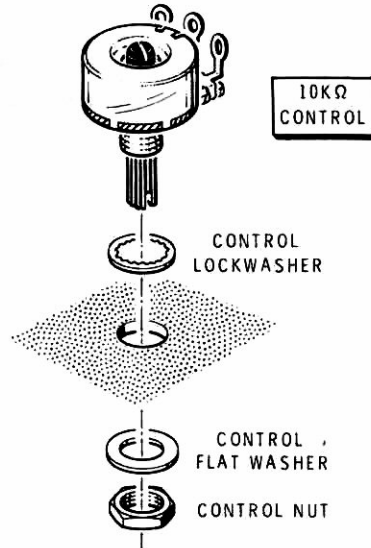

Detail 12-24E

- () R7: Refer to Detail 12-24E and install a 10 kΩ control (#10-88) at R7 on the rear panel. Use a control lockwasher, a control flat washer, and a control nut.
- () R8: Similarly, install a 10 kΩ control at R8. Use a control lockwasher, a control flat washer, and a control nut.

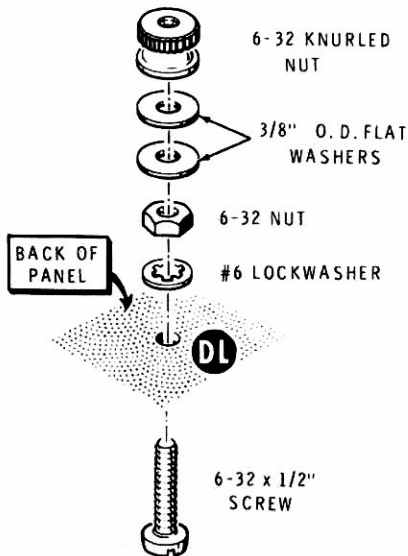

Detail 12-24D

- () Refer to Detail 12-24D and install a 6-32 x 1/2" screw, a #6 lockwasher, a 6-32 nut, two 3/8" OD flat washers, and a 6-32 knurled nut at hole DL.

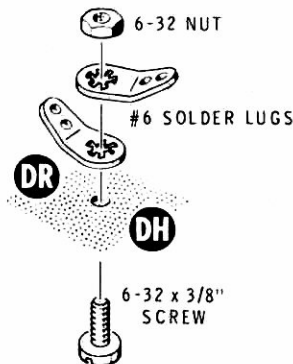

Detail 12-24F

- () Refer to Detail 12-24F and install two #6 solder lugs on the back of the panel at DH and DR. Use 6-32 x 3/8" hardware.

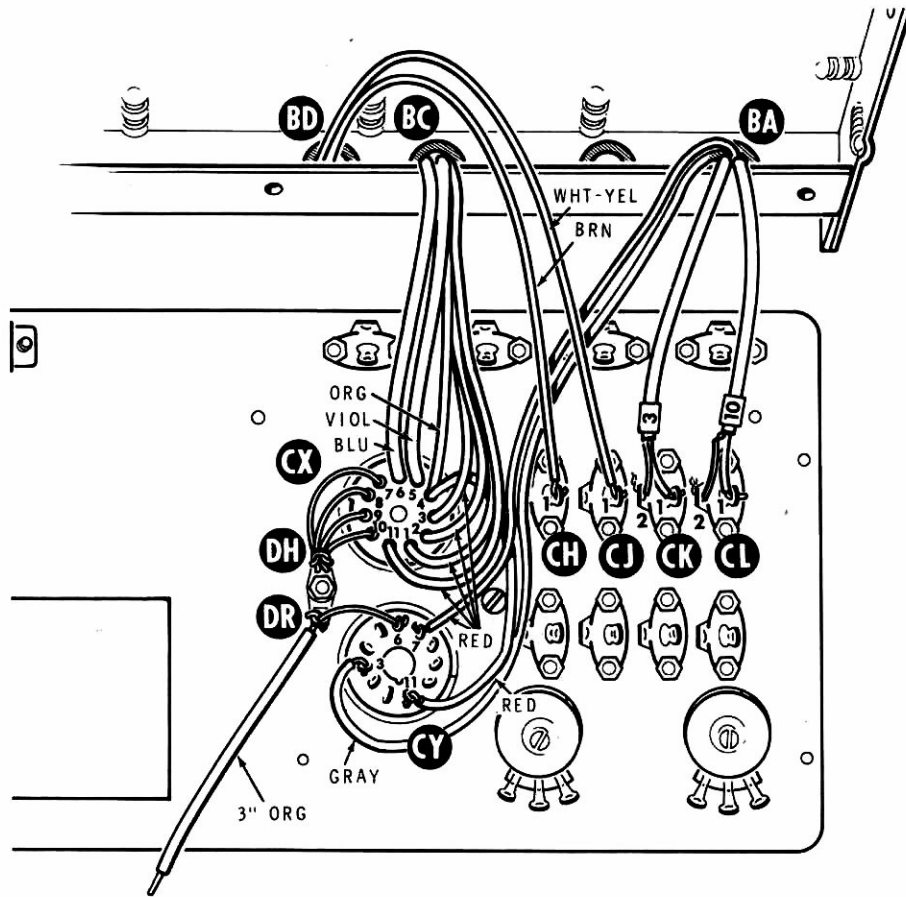

PICTORIAL 12-25

Refer to Pictorial 12-25 for the following steps.

() Cut the following lengths of small bare wire:

- 2"
- 2-1/4"
- 2-1/2"
- 2-3/4"

() Refer to Detail 12-25A and connect the bare wires from solder lug DH to the appropriate pin of plug CX. The pin numbers are molded on the back of the plug. Cut off the excess lead lengths after soldering. Apply solder sparingly and avoid getting solder on the outside of the pin. When the pin is hot enough, the solder will run up inside the pin by capillary action.

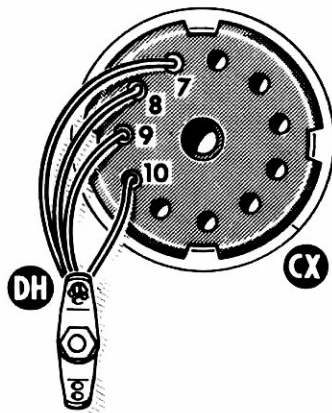

PUSH THE WIRE INTO THE HOLE UNTIL IT COMES OUT OF THE END OF THE PIN. APPLY SOLDER TO THE TIP OF THE HEATED PIN. SOLDER WILL FLOW UP INTO THE PIN BY CAPILLARY ACTION. CUT OFF THE EXCESS WIRE AT THE END OF THE PIN.

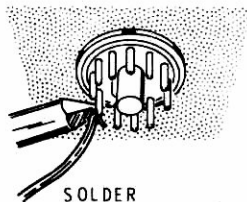

Detail 12-25A

- 2" from DH (NS) to pin 10 (S-1).
- 2-1/4" from DH (NS) to pin 9 (S-1).
- 2-1/2" from DH (NS) to pin 8 (S-1).
- 2-3/4" from DH (S-4) to pin 7 (S-1).

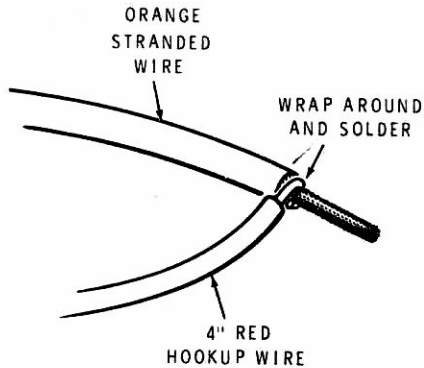

Detail 12-25B

- () Position the rear panel near the chassis as shown on the Pictorial.
- () Remove an additional 3/8" of insulation (total 3/4") from each of the seven wires coming from grommet BC.
- () Prepare a 4" red wire.
- () Refer to Detail 12-25B and just below the insulation, wrap one end of the 4" red wire around the orange stranded wire coming from grommet BC (S-1).
- () Push the end of the orange stranded wire into pin 4 of plug CX until the wire emerges from the end of the pin and the end of the wire insulation is covered by the plug. Refer to Detail 12-25C and solder the wire to the plug tip.

PUSH THE WIRE INTO THE HOLE UNTIL IT COMES OUT OF THE END OF THE PIN. APPLY SOLDER TO THE TIP OF THE HEATED PIN. SOLDER WILL FLOW UP INTO THE PIN BY CAPILLARY ACTION. CUT OFF THE EXCESS WIRE AT THE END OF THE PIN.

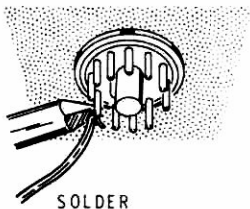

Detail 12-25C

- () Connect the free end of the 4" red wire coming from pin 4 of plug CX to socket CY lug 11 (S-1).
- () Connect the other six wires coming from grommet BC to the pins of plug CX as follows. Solder each wire to the tip of its pin:
 - Blue to pin 6
 - Violet to pin 5
 - Red to pin 11
 - Red to pin 3
 - Red to pin 2
 - Red to pin 1
- () Tug gently on each wire to make sure it is well soldered.
- () Cut off excess lead lengths at the tip of each pin.
- () Inspect the outside of each pin for the presence of solder. If you find any, shave it off with a sharp knife so the pins can enter the power cable socket without interference.
- () Connect the red wire coming from grommet BA to socket CY lug 7 (S-1).
- () Connect the gray wire coming from grommet BA to socket CY lug 3 (S-1).

Connect the two shielded cables coming from grommet BA as follows. Use 5/8" of small sleeving on the shield wire of each cable.

- () Center conductor of cable 3 to phono socket CK lug 1 (S-1), and the shield wires to lug 2 (S-1).
- () Center conductor of cable 10 to phono socket CL lug 1 (S-1), and the shielded wires to lug 2 (S-1).
- () Connect the brown wire coming from grommet BD to phono socket CH lug 1 (S-1).
- () Connect the white-yellow wire coming from grommet BD to phono socket CJ lug 1 (S-1).
- () Connect a 1-1/2" bare wire from socket CY lug 6 (S-1) to solder lug DR (NS).
- () Cut a 3" orange stranded wire. Remove 3/8" of insulation from each end. Melt a minimum amount of solder on each bare end to hold the fine strands together.
- () Connect one end of this wire to solder lug DR (S-2). The other end will be connected later.

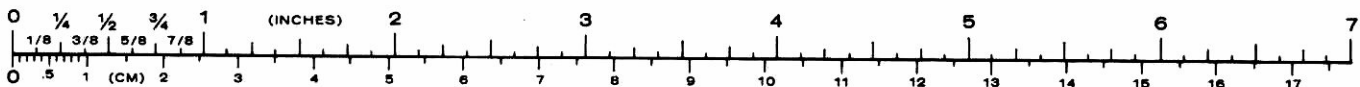

Refer to Pictorial 12-26 for the following steps.

() Prepare the following gray wires:

4" 2-3/4"

() Connect the 2-3/4" gray wire from phono socket CP lug 1 (NS) to control R8 lug 3 (S-1).

() Connect the 4" gray wire from phono socket CR lug 1 (S-1) to control R7 lug 3 (NS).

Connect the shielded cables coming from grommet BB as follows. Use 5/8" of small sleeving on the shield wire of each cable.

() Center conductor of cable 14 to phono socket CN lug 1 (S-1), and the shield wires to lug 2 (S-1).

() Center conductor of cable 1 to phono socket CS lug 1 (S-1), and the shield wires to lug 2 (S-1).

() Center conductor of cable 17 to control R7 lug 3 (S-2), and the shield wires to lug 1 (NS).

() Center conductor of cable 16 to control R7 lug 2 (S-1), and the shield wires to lug 1 (S-2).

() Center conductor of cable 2 to phono socket CP lug 1 (S-2), and the shield wires to lug 2 (S-1).

() Center conductor of cable 15 to control R8 lug 2 (S-1), and the shield wires to lug 1 (S-1).

Connect wires from grommet BD to socket CY as follows:

() Yellow to lug 8 (S-1).

() Violet to lug 9 (S-1).

() Blue to lug 10 (S-1).

() White-red to lug 5 (S-1).

() Two white-black to lug 2 (S-2).

() White-violet-violet to lug 1 (S-1).

NOTE: The large orange wire from grommet BD will be connected later.



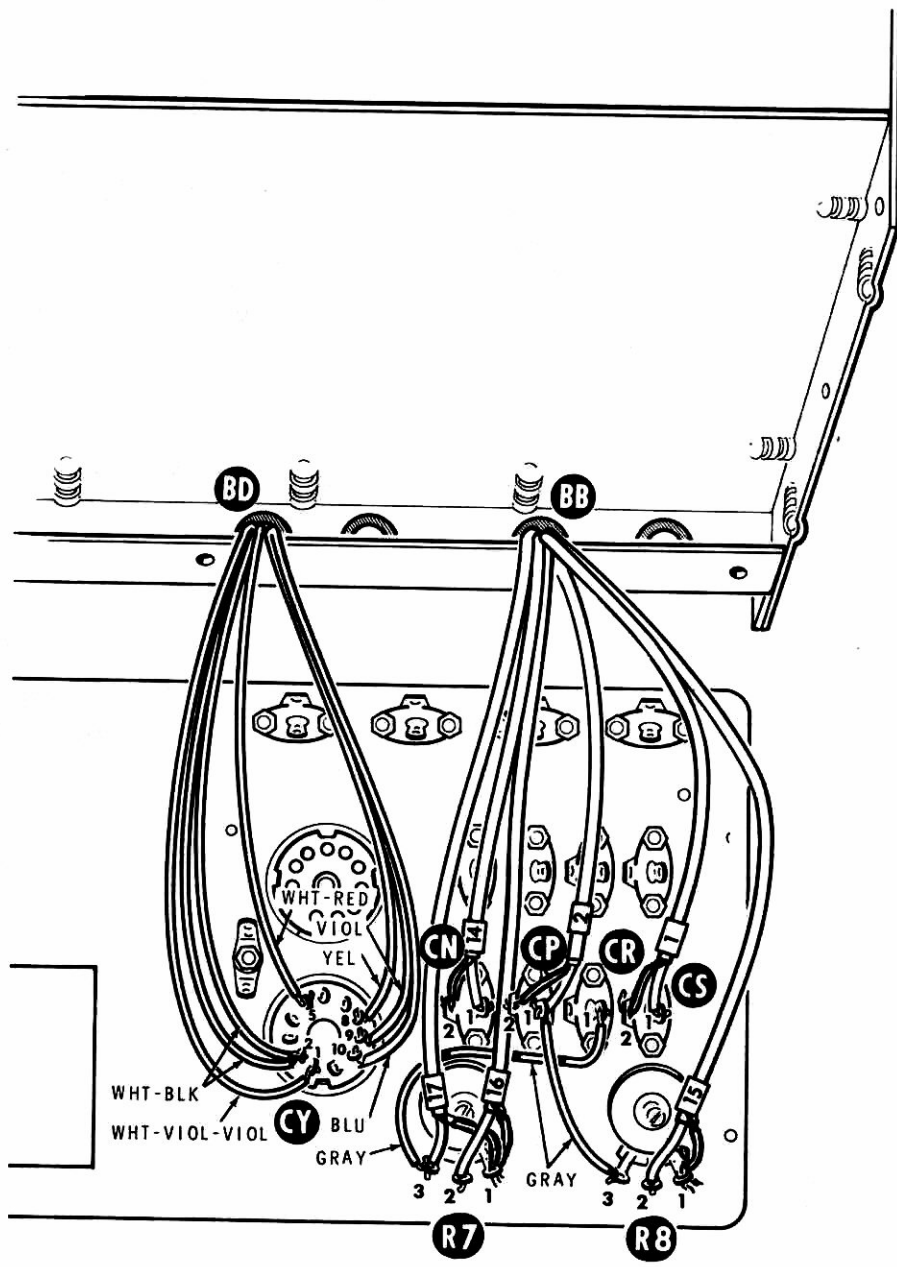

PICTORIAL 12-26

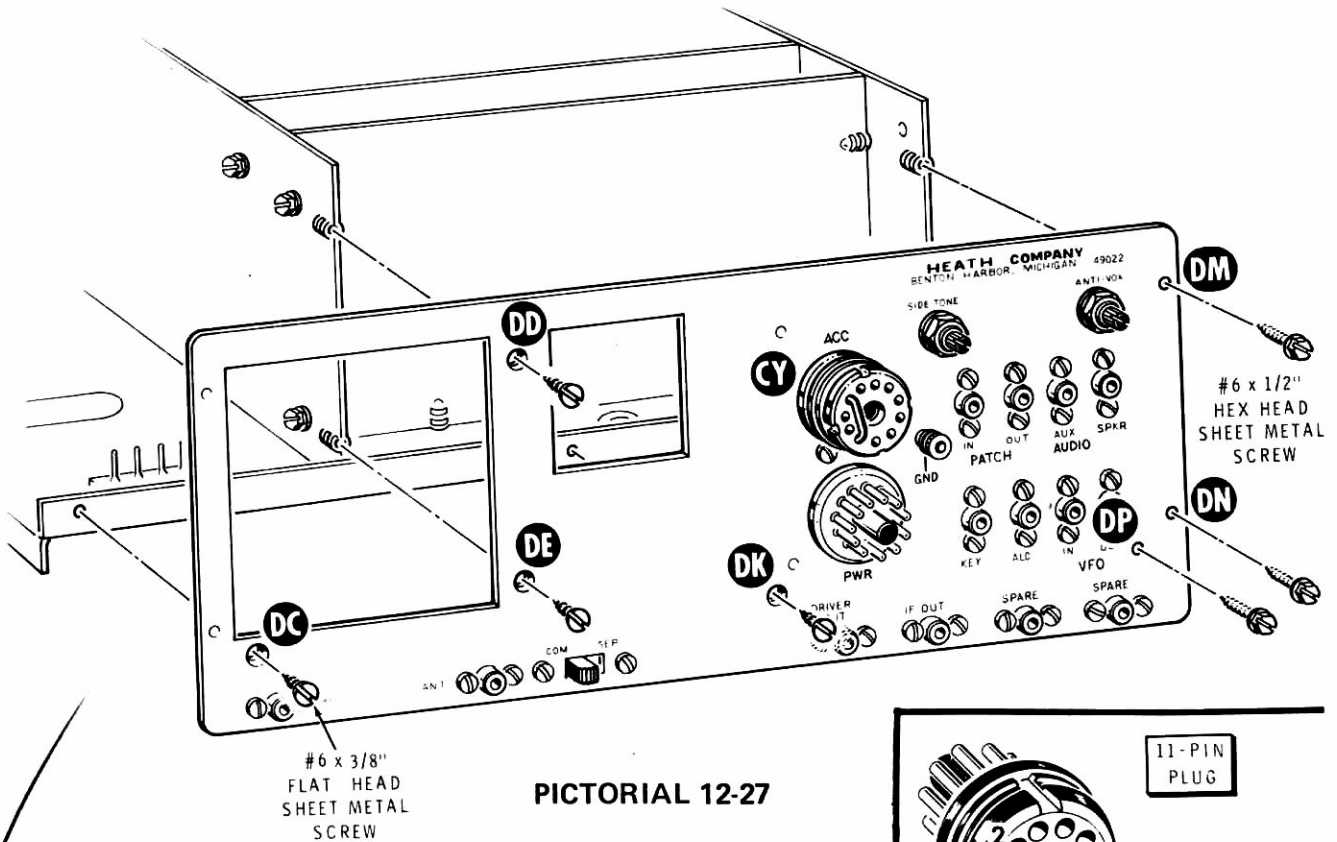

PICTORIAL 12-27

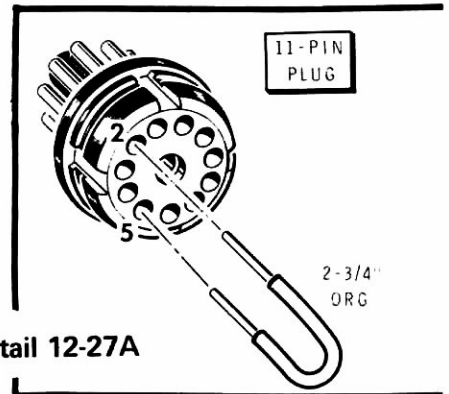

Detail 12-27A

- () Refer to Pictorial 12-27 and attach the rear panel to the back of the chassis and the shields. Use #6 x 3/8" flat head sheet metal screws at DC, DD, DE, and DK. Use #6 x 1/2" hex head sheet metal screws at DM, DN, and DP. CAUTION: Inspect the junction of the panel and chassis carefully to make sure no wires have been pinched between the two pieces.
- () Use an ohmmeter to check for short circuits at each phono socket. Connect the common lead to the panel and insert the other probe into the phono socket to contact the center conductor. Be sure the free ends of the harness wires not yet connected are not touching the chassis or each other.
- () Refer to Detail 12-27A and prepare a 2-3/4" orange wire by removing 1/2" of insulation from each end.
- () From the back of the remaining 11-pin plug, push the ends of the orange wire into pins 2 and 5. Solder the wires at the pin tips and cut off any excess wire lengths.
- () Insert the plug as far as it will go into socket CY on the rear panel.
- () An octal plug cap is furnished for this plug. Install it now, if desired.

UNDER-CHASSIS WIRING

Refer to Pictorial 12-28 (Illustration Booklet, Page 12) for the following steps.

- () With the bottom edge of the rear panel uppermost, as shown in the Pictorial, sight along the panel edge from one end and bend down any lugs 2 of the phono sockets which project above the panel edge.

NOTE: Shift the wiring harness as necessary when making connections. Be careful not to touch any insulated wires with the soldering iron.



- () Connect the center conductor of the shielded cable coming from F11 to phono socket CE lug 1 (S-1), and the shield wires to lug 2 (S-1).
- () Connect the center conductor of the shielded cable coming from G24 to switch S5 lug 2 (S-1). Do not connect the shield wires yet.
- () Connect the center conductor of the shielded cable coming from relay RY lug 1 to switch S5 lug 3 (S-1). Do not connect the shield wires yet.
- () Refer to Detail 12-28A and prepare a 5-1/4" shielded cable.

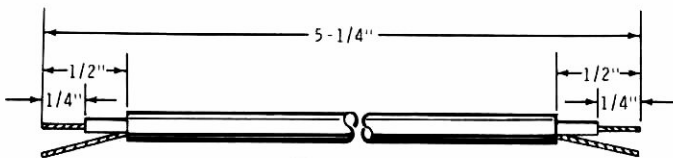

Detail 12-28A

- () Connect the center conductor at one end to switch S5 lug 1 (S-1), and the shield wires to lug 4 (S-1). At the other end, connect the center conductor to phono socket CA lug 1 (S-1) and the shield wires to lug 2 (NS).
- () C3: Connect the lead marked + of a 50 μ F (may be marked 50 MFD) electrolytic capacitor to H5 (S-1/4) and the other lead to phono socket CA lug 2 (NS). Position this capacitor so no part of its body projects above the edge of the rear panel.
- () C12: Connect the lead from the positive (+) marked end of a 500 μ F electrolytic capacitor to J1 (S-1/5) and connect the other lead to phono socket CA lug 2 (S-3).
- () Connect the shield wires of the cable coming from G23 to switch S5 lug 5 (S-1).
- () Connect the shield wires of the cable coming from solder lug BW to switch S5 lug 6 (S-1).
- () Connect the center conductor of the shielded cable coming from H3 to phono socket CD lug 1 (S-1), and the shield wires to lug 2 (S-1).
- () Cut three 11" RG-58A/U coaxial cables.

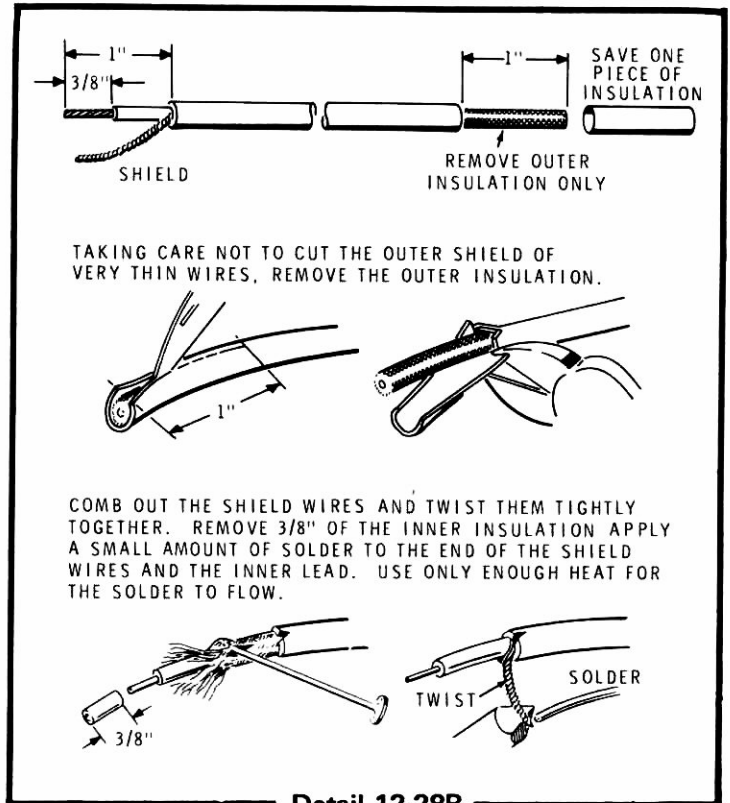

Detail 12-28B

- () Refer to Detail 12-28B and prepare three 11" coaxial cables as shown. At one end of each cable, carefully cut the outer insulation completely around the cable and slide off the 1" length of insulation in one piece. Save one of these pieces for use later.
- () Refer to Detail 12-28C and install a phono plug on the other end of each coaxial cable. Be sure to use plug #438-46.

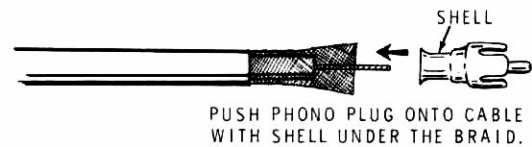
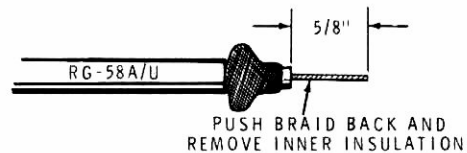

Detail 12-28C

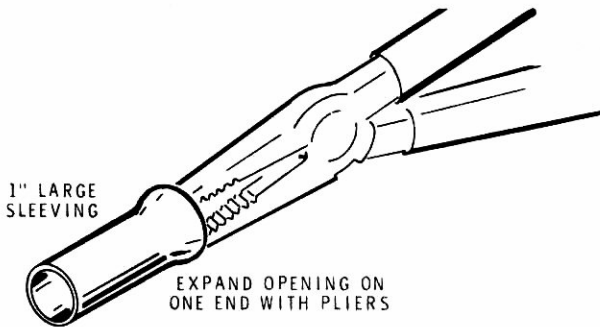

Detail 12-28D

- () Refer to Detail 12-28D and expand the opening at one end of a 1" length of large sleeving with pliers.
- () Prepare two more 1" lengths of sleeving in the same manner.
- () Refer to Detail 12-28E and, starting at the other end of the cable, push the expanded end of the sleeving along the cable and up over the braid soldered to the shell of the phono plug. Do this on all three 11" coaxial cables.

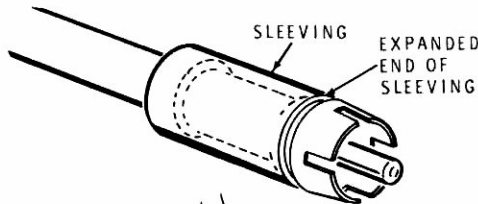

Detail 12-28E

- () As before, pass a flame back and forth under all sides of each large sleeving to shrink it tightly in place.
- () Trim the 1" length of outer insulation (saved earlier) to 3/4". Then slide the insulation onto a braid pigtail on one of the 11" coaxial cables. Connect the braid pigtail to phono socket CB lug 2 (S-1), and the center conductor to lug 1 (S-1).
- () Slide the piece of insulation completely over phono socket lug 2 so the two phono socket lugs cannot short-circuit if they get accidentally bent.



- () Connect the center conductor of a coaxial cable to relay RY lug 5 (S-1), and the shield wires to solder lug BK (NS).
- () Connect the center conductor of the third coaxial cable to relay RY lug 9 (S-1), and the shield wires to solder lug BK (S-2/3). If you cannot push these shield wires through the solder lug hole, wrap them around the bare wire between solder lug BK and lug 13 of the relay. Be sure to solder both pigtails.
- () Refer to Detail 12-28F and, from the label sheet, cut out strips of four groups each of PA, LO, HI, OUT and IN.

CUT OUT STRIPS
OF FOUR EACH

SPD-08E	PA	LO	HI	OUT	IN					
	PA	LO	HI	OUT	IN					
	PA	LO	HI	OUT	IN					
	PA	LO	HI	OUT	IN					
	PA	LO	HI	OUT	IN					
	PA	LO	HI	OUT	IN					

Detail 12-28F

- () Refer to Detail 12-28G, remove the protective backing from the letters PA, and wrap the adhesive side around the black sleeving of the phono plug at the other end of the coaxial cable connected to relay RY lug 5. The letter strips are long enough to overlap.
- () Similarly, apply letters to the phono plug sleeving on the other cables as follows:

Letters IN to cable from relay RY lug 9.
 Letters OUT to cable from phono socket CB.
 Letters HI to small cable from H3 and chassis cutout BL.
 Letters LO to small cable from relay RY lug 1 and chassis cutout BL.

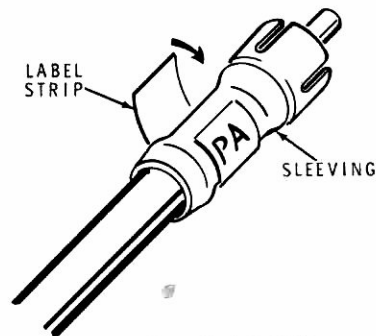

Detail 12-28G

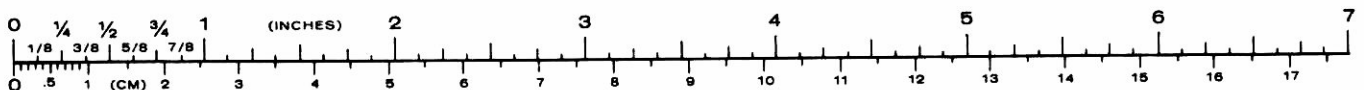

() Push the three large coaxial cables through chassis cutout BL (the two shielded cables, now HI and LO, were previously pushed through cutout BL).

() Check the under-chassis wiring against the steps and the Pictorials to make sure there are no errors.

This completes the under-chassis wiring.

TOP CHASSIS

Refer to Pictorial 12-29 (Illustration Booklet, Page 12) for the following steps.

() Connect the center conductor of shielded lead 6 to control R9 lug 2 (S-1), and the shield wires to the control solder lug at lug 1 (NS).

() Connect the center conductor of shielded lead 7 to control R9 lug 3 (S-1), and the shield wires to lug 1 (NS).

() Prepare a 3-1/2" gray wire. Connect one end to control R9 lug 1 (S-3). The other end will be connected later.

() Connect the yellow wire coming from BO#11 to R15 lug 2 (S-1).

() Connect the red wire coming from switch S2 section F to control R15 lug 6 (S-2).

() Connect a 2-1/4" length of small bare wire from control R3 lug 1 (NS) to the control solder lug at R15 (NS).

() Connect the gray wire coming from switch S2 section F to the control solder lug at R15 (S-3).

() Connect the center conductor of the shielded cable coming from control R2 lug 3 to control R3 lug 3 (S-1), and the shield wires to lug 1 (NS).

() Connect the center conductor of shielded lead 12 to control R3 lug 2 (S-1), and the shield wires to lug 1 (S-3).

() Prepare a 9" red wire.

() Clip the four male terminals from their retaining bands so each appears as shown in Detail 12-29A.

Refer to Detail 12-29A and install male terminals (#432-152) on wires as follows:

() Male terminal on the 9" red wire (S-1).

() Male terminal on the center conductor of shielded lead 10 (S-1).

() Male terminal on shield wires of shielded lead 10 (S-1).

() Male terminal on gray wire coming from switch S3 section B (S-1).

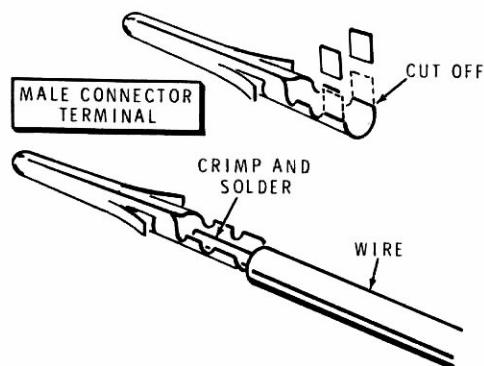

Detail 12-29A

CAUTION: In the following steps, be sure you insert each terminal into the proper hole (once a terminal is installed, it cannot be removed).

() Refer to Detail 12-29B (Illustration Booklet, Page 12) and push each of the four connectors into the connector housing until the "ears" expand to hold the connectors in place, as shown in the inset drawing. Be sure to insert the connectors in the proper holes, as they cannot be removed. Select the holes based upon their position relative to the index notch.

() Push shielded leads 1, 4, and 11 back through chassis cutout AA. They will be connected later.

() Connect the black wire coming from BO#13 to control R1 lug 2 (S-1).

() Connect the white-black wire coming from BO#13 to control R1 lug 1 (S-1).



POSITION THE SMALL PORTION OF THE GROMMET INTO THE CHASSIS HOLE.



BEND THE LARGE PORTION OF THE GROMMET OVER AND INTO THE SMALL PORTION. PRESS IT FIRMLY INTO PLACE.

Detail 12-30A

Refer to Pictorial 12-30 (Illustration Booklet, Page 13) for the following steps.

- () Refer to Detail 12-30A and install a small plastic grommet in the lateral shield at DR.
- () S4: Refer to Detail 12-30B and mount a single wafer rotary switch at S4 on the lateral shield. Use #4 lockwashers and 4-40 nuts. Be sure to position the terminals as shown.
- () Connect the gray wire coming from the control solder lug at R2 to switch S4 lug 1 (NS).
- () Prepare a 2" gray wire. Connect one end of this wire to switch S4 lug 1 (S-2). The other end will be connected later.
- () Connect the white-red-red wire coming from BO#13 to switch S4 lug 2 (S-1).
- () Connect the white-gray-gray wire coming from BO#13 to switch S4 lug 3 (S-1).

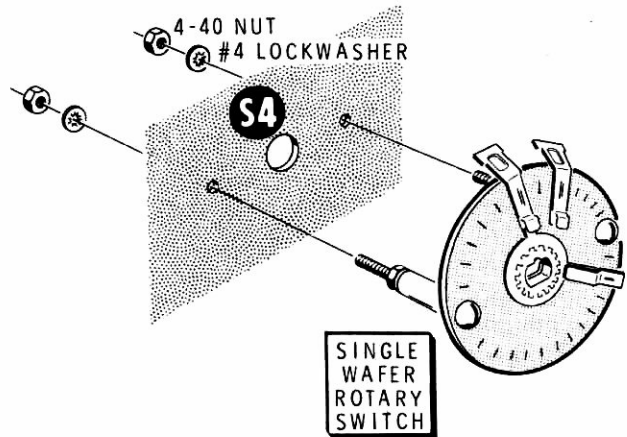

Detail 12-30B

CAUTION: When you wire the following switch, be sure you have the color dot in the proper position for each step.

- () Refer to Detail 12-30C and connect a 2-1/2" small bare wire to switch S1 wafer B from lug 12 (S-1), against lug 11 (S-2), against lug 10 (S-2), and through lug 9 (S-2) to lug 7 (NS). Be sure the color dots on the edges of the switch wafers are positioned as shown. The wire should touch lugs 11 and 10, go through lug 9, curve around lug 8 (provide at least 1/8" clearance), and then connect to lug 7. Excepting lug 7, all connections are soldered.

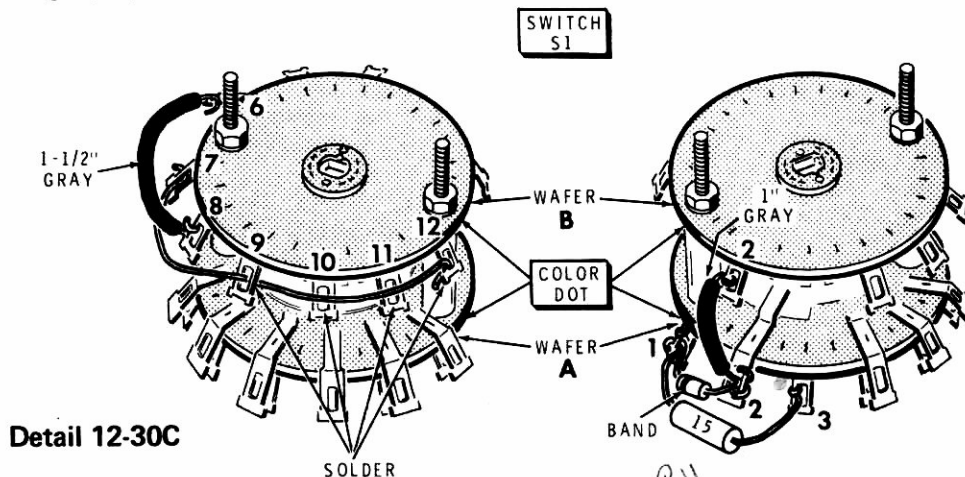

Detail 12-30C

- () Prepare 1-1/2" and 1" gray wires.
- () Connect the 1-1/2" gray wire to switch S1 wafer B: from lug 8 (S-1) to lug 6 (NS).
- () Connect the 1" gray wire to switch S1 from wafer B lug 2 (NS) to wafer A lug 2 (NS).
- () Connect the lead at the banded end of a type VR 9.1 zener diode (#56-19) to switch S1, wafer A, lug 1 (NS). Connect the other lead to lug 2 (S-2).
- () R11: Connect a 15 Ω , 1-watt (brown-green-black) resistor to switch S1 wafer A from lug 1 (S-2) to lug 3 (NS).
- () S1: Refer to Detail 12-30D and mount the 2-wafer rotary switch at S1 on the lateral shield. Use #4 lockwashers and 4-40 nuts.
- () Connect the gray wire coming from switch S4 to switch S1, wafer B, lug 2 (S-2).
- () Connect the white-orange wire coming from BO#13 to switch S1, wafer B, lug 6 (S-2).
- () Remove an additional 1/4" of insulation from the white-red wire coming from BO#13.
- () Connect the white-red wire to switch S1 wafer B by pushing it through lug 5 (S-2) to lug 4 (S-1).
- () Connect the white-yellow wire coming from BO#13 to switch S1, wafer B, lug 7 (S-2).

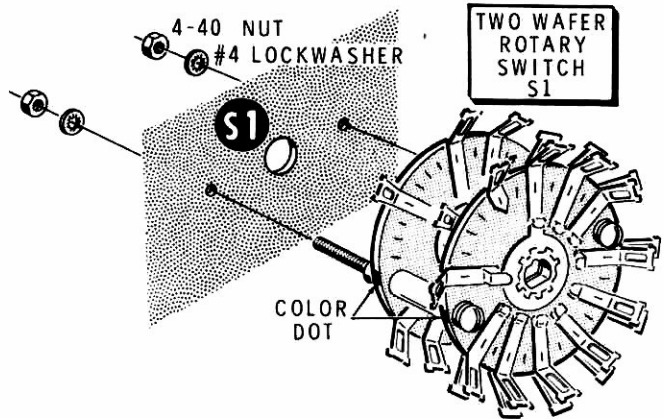

Detail 12-30D

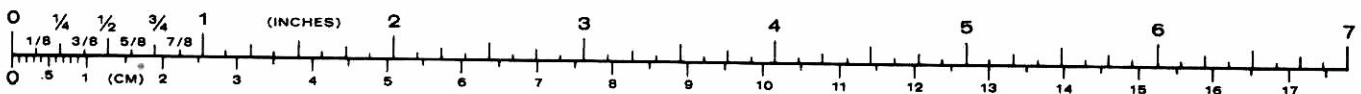

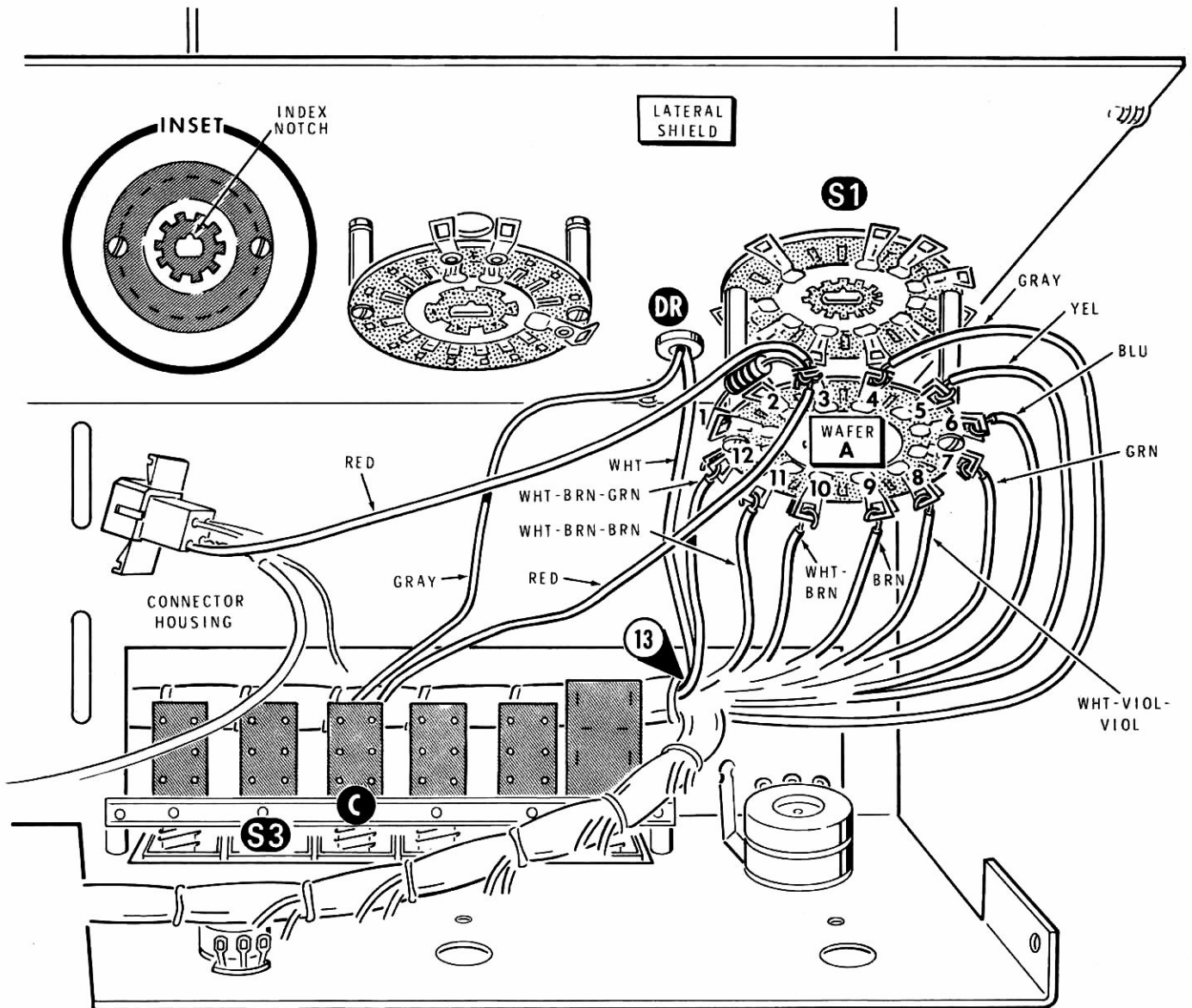

PICTORIAL 12-31



Refer to Pictorial 12-31 for the following steps.

- () Push the gray wire coming from switch S3 section C through grommet DR in the lateral shield.
- () Push the white wire coming from BO#13 through grommet DR.
- () Connect the red wire coming from the white connector housing to switch S1, wafer A, lug 3 (NS).
- () Connect the red wire coming from switch S3 section C to switch S1, wafer A, lug 3 (S-3).

NOTE: Wires will be connected to switch S1 wafer A in the following steps. Each wire must be connected to the two lugs, on the front and the back of the wafer, at each location. The solder step will call for "S-2." Be very sure each wire is soldered to both lugs.

Connect the nine wires coming from BO#13 to switch S1 wafer A as follows:

- () White-brown-green to lug 12 (S-2).
- () White-brown-brown to lug 11 (S-2).
- () White-brown to lug 10 (S-2).
- () Brown to lug 9 (S-2).
- () White-violet-violet to lug 8 (S-2).
- () Green to lug 7 (S-2).
- () Blue to lug 6 (S-2).
- () Yellow to lug 5 (S-2).
- () Gray to lug 4 (S-2).
- () Refer to the inset drawing of Pictorial 12-31 and position the rotors of all three switch wafers so the index notch is up. You may wish to use one of the switch shafts to turn the rotors.

Refer to Pictorial 12-32 (Illustration Booklet, Page 13) for the following steps.

NOTE: In the following steps you will prepare the red window on the front panel and the optional station identification display. If you wish to use the identification

feature, your station call letters will be displayed in the red window between the meter and the frequency display windows. If you do not want this display, the area of the red window in front of the panel opening at EF (plus 1/8" on each side) should be covered with the black opaque tape furnished. This prevents any light leakage from the panel opening. The lamp in socket PL2 will then not be needed.

- () Place a soft cloth on your work table so the front panel will not be scratched.
- () Identify the red window as a piece of plastic approximately 14" long x 1" wide, covered with brown paper. DO NOT remove the paper yet.
- () Refer to Detail 12-32A and place the red window on the front panel so it is centered laterally, and parallel to the three rectangular openings.
- () Make a pencil mark across the red window paper 1/8" in from each end of opening EF.

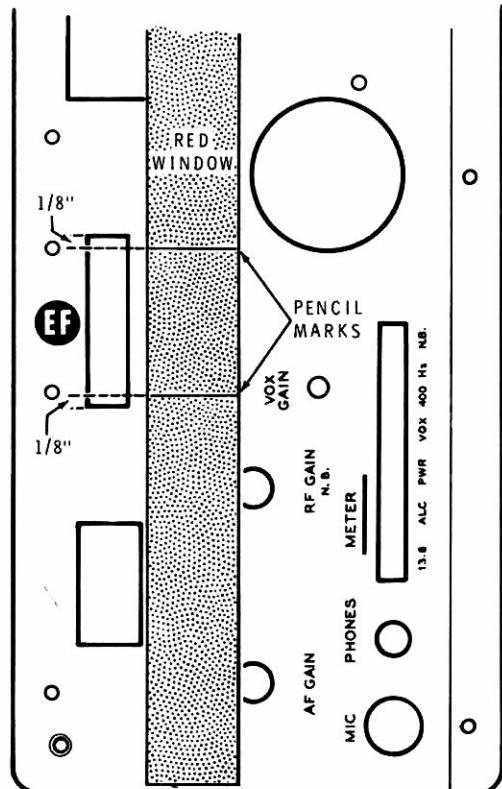

Detail 12-32A

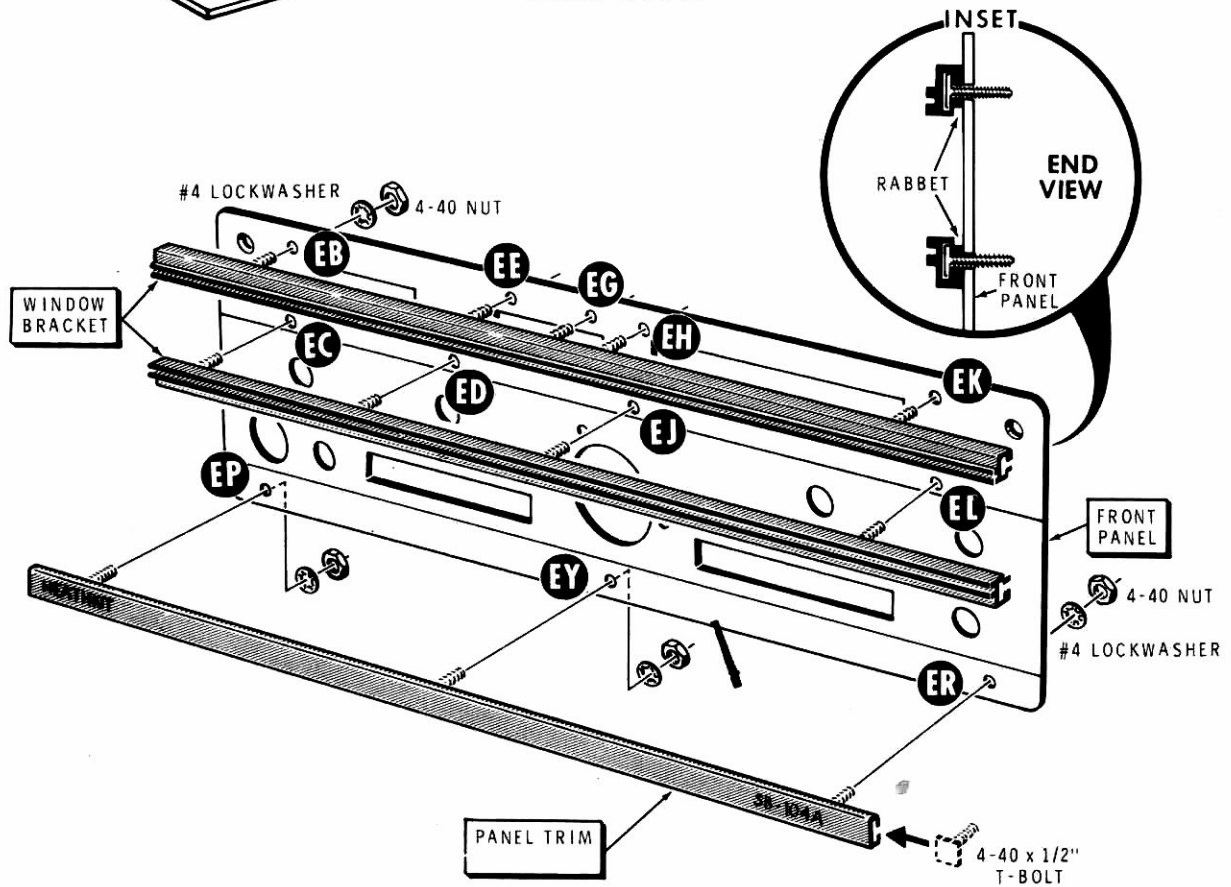
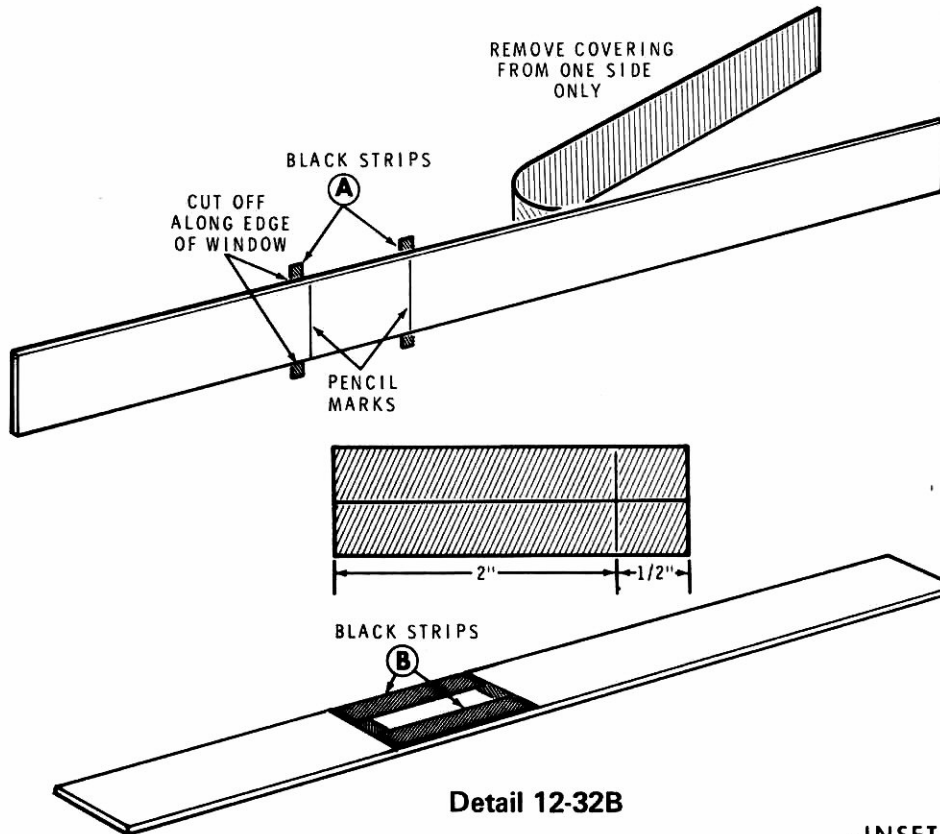

Refer to Detail 12-32B for the next four steps.

- () Remove the covering from one side of the red window.
- () Remove one strip of the black label from its backing, cut it in half, and apply the adhesive sides of the two pieces against the back of the red window with their inner edges aligned with the pencil marks on the covering as shown at (A).
- () One at a time, remove the backing and apply the two strips of black label to the back of the red window between the two strips previously applied, with one edge of each tape along the outer edge of the red window as at (B).
- () Cut off any excess of strips (A) along the edges of the red window.

Refer to Detail 12-32C for the next five steps.

- () Slide three 4-40 x 1/2" T-bolts into the channel of the panel trim strip. From the front of the panel, insert the T-bolts into holes EP, EY, and ER on the front panel. Center the trim strip on the panel and secure the T-bolts with #4 lockwashers and 4-40 nuts.
- () Slide five 4-40 x 1/2" T-bolts into the slots of a window bracket.
- () From the front of the panel, insert the T-bolts into holes EB, EE, EG, EH, and EK with the window rabbet down as shown in the inset drawing.
- () Slide four 4-40 x 1/2" T-bolts into the remaining window bracket.
- () Insert the T-bolts into holes EC, ED, EJ, and EL with the rabbet facing up.
- () Hold the window brackets in place with one hand and turn the panel over so the panel rests on its front (printed side) and the ends of the T-bolts are up.
- () Refer to Detail 12-32D and place a #4 lockwasher and a 17/32" spacer (tapped) on the T-bolts at EH, EJ, EK, and EL. Leave the spacers loose.

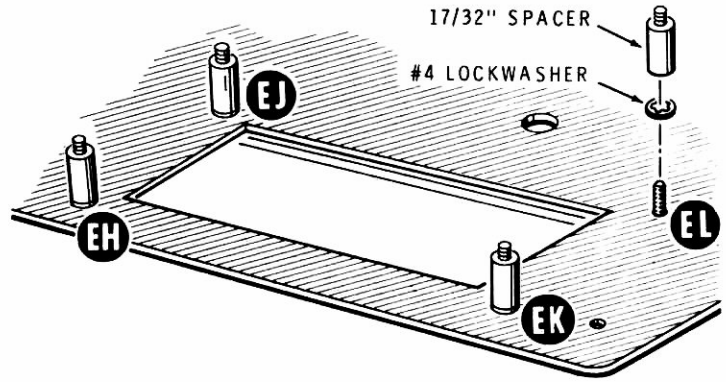

Detail 12-32D

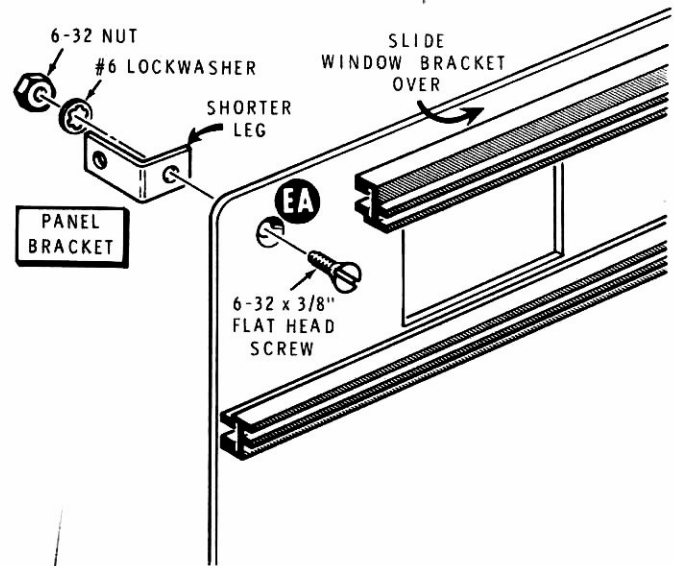

Detail 12-32E

- () Refer to Detail 12-32E and install a panel bracket on the rear of the panel at EA. Mount the shorter leg of the bracket against the panel. Use 6-32 x 3/8" flat head hardware. Slide the window bracket to one side enough to clear the hole.
- () Similarly, mount a panel bracket at EN.
- () Remove the covering from the front of the red window.
- () Wipe off the red window with water and detergent to remove all fingerprints. DO NOT SOAK. After drying, grasp the window only by the edges.

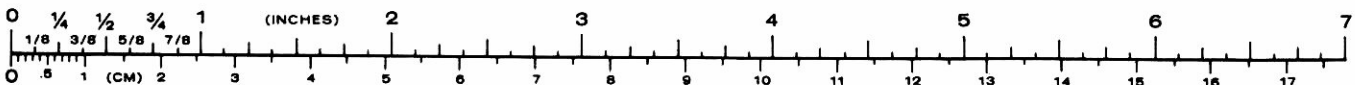

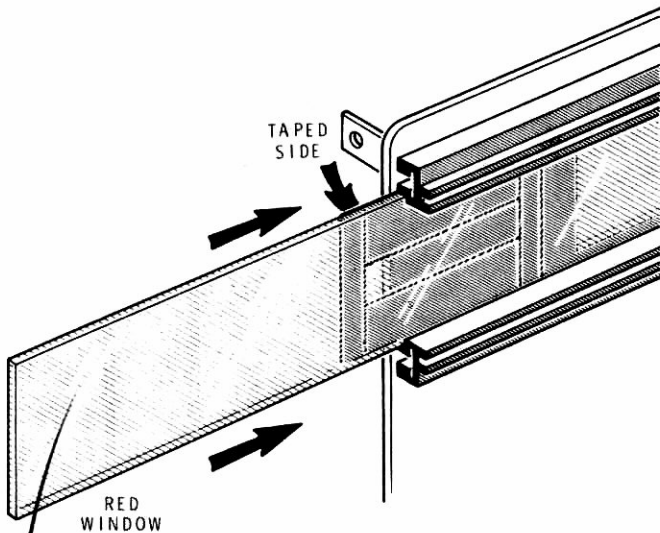

Detail 12-32F

() Refer to Detail 12-32F and carefully slide the edges of the red window into the rabbets in the window brackets with the taped side toward the panel and aligned with opening EF. Center the window brackets and the red window on the panel and tighten the four hex spacers.

() Refer to Detail 12-32G and, at the end opposite the hole, bend 1/4" of the end of each call letter clip as shown.

() Refer to Detail 12-32G and place a call letter clip, a #4 lockwasher, and a 4-40 nut on the T-bolts at EE and EG. Leave the nuts finger tight only.

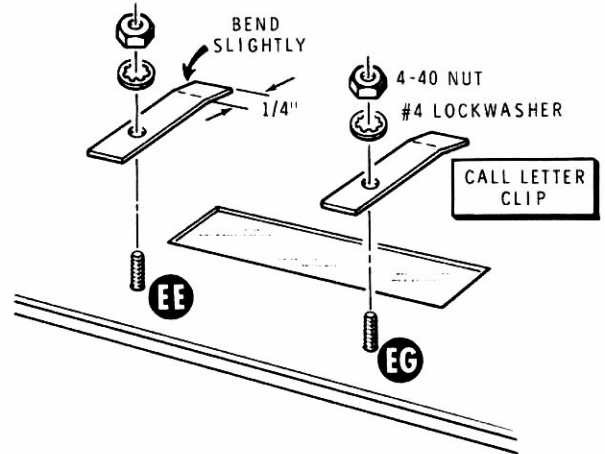

Detail 12-32G

() Refer to Detail 12-32H and install a meter bracket at EC. Use a 3/8" hex spacer and a #4 lockwasher. Leave the spacer loose.

() PL2: Install a meter bracket and the pilot lamp socket with the longer bracket (#434-44) at ED. Use a #4 lockwasher and a 4-40 nut. Leave the nut loose.

() Install a #4 lockwasher and a 4-40 nut on screw EB.

NOTE: In the following steps, bend the meter brackets (if necessary) so they hold the meter firmly.

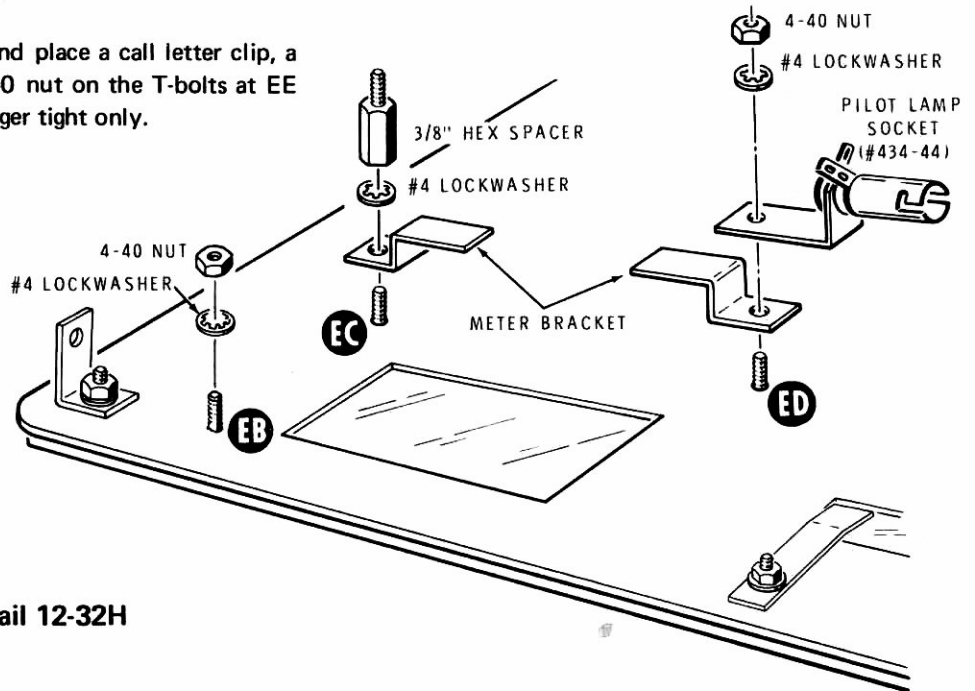

Detail 12-32H

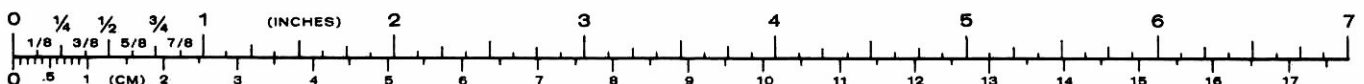

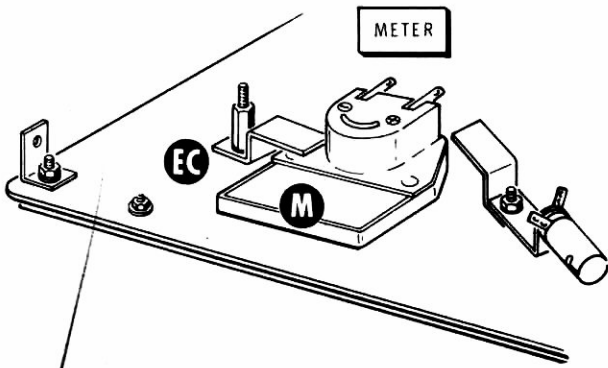

Detail 12-32J

- () M: Refer to Detail 12-32J and install the meter at M. Fit the meter face into the panel opening. Then position the meter clamp from EC against the meter case and tighten the hex spacer.
- () Inspect the meter terminals carefully. If you find a small wire connecting the two terminals, remove and discard it.
- () Prepare a 2" gray wire.
- () Connect one end of the gray wire to the "-" terminal of the meter (S-1). The other end will be connected later.

NOTES:

1. If you wish to use the call letter display, this note and the following steps tell you how to mount your call letters on a clear plastic identification strip which will be mounted in a panel opening.
2. The letters of your call will be centered on the identification strip. You will start at the center of the strip and work first to the right end of your call and then to the left. First, determine the center line of your call:

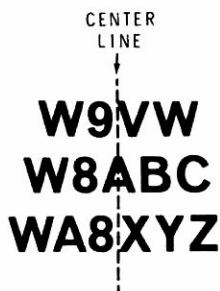

- () Remove any covering from the clear plastic identification strip.
- () Start at the center of your call and remove the letters, one at a time, from the call letter label sheet and press the adhesive side into position on the clear plastic identification strip. Tweezers may help you to position the letters properly. The edges of the labels must overlap each other slightly to prevent light leakage, so proper alignment of the labels on the strip is important.

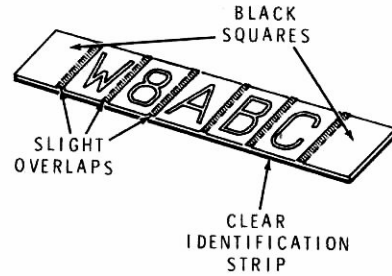

- () After you have your call letters centered on the identification strip, fill the remaining clear spaces at each end of your call with black squares. Remember to overlap the edges.

Refer to Detail 12-32K for the next two steps.

- () Place the identification strip into opening EF so the letters will appear correctly when viewed from the front panel.
- () Place the white plastic diffuser strip into opening EF.

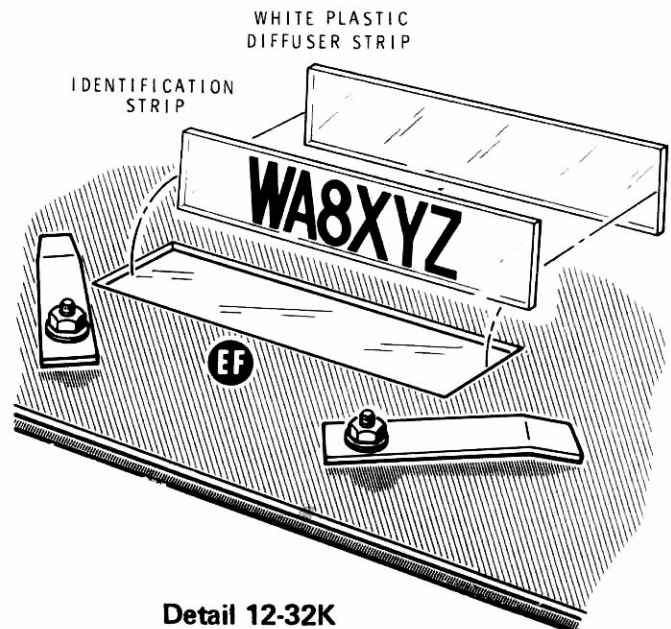

Detail 12-32K

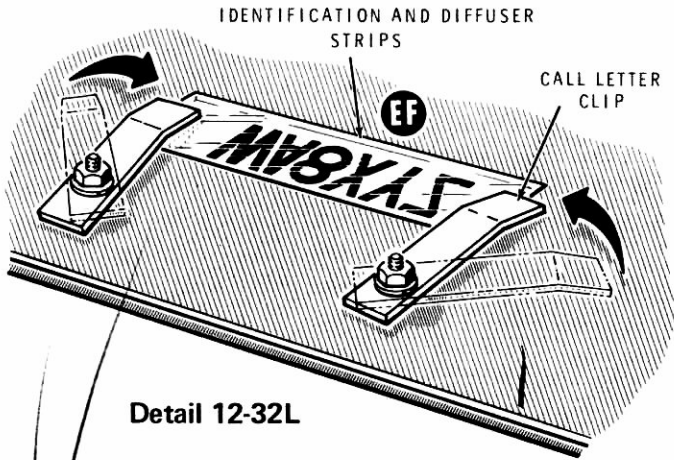

Detail 12-32L

- () Refer to Detail 12-32L, position the corners of the two call letter clips against the back of the diffuser strip and tighten the nuts.
- () Insert a #1813 lamp into the pilot lamp socket at PL2 and place a lamp shield on the lamp.
- () Place the meter clamp at ED against the back of the meter and position the pilot lamp so it will illuminate the back of the identification strip. Then tighten the nut at ED.
- () PL1: Mount the remaining pilot lamp socket on the hex spacer at EC. Use a #4 lockwasher and a 4-40 nut.

TWISTED PAIR



Detail 12-32M

- () Refer to Detail 12-32M and form a twisted pair from the two wires.
- () Connect one end of the twisted pair to PL2: the gray wire to lug 2 (S-1) and the orange wire to lug 1 (S-1).
- () Connect the other end of the twisted pair to PL1: the orange wire to lug 1 (NS) and the gray wire to lug 2 (NS).

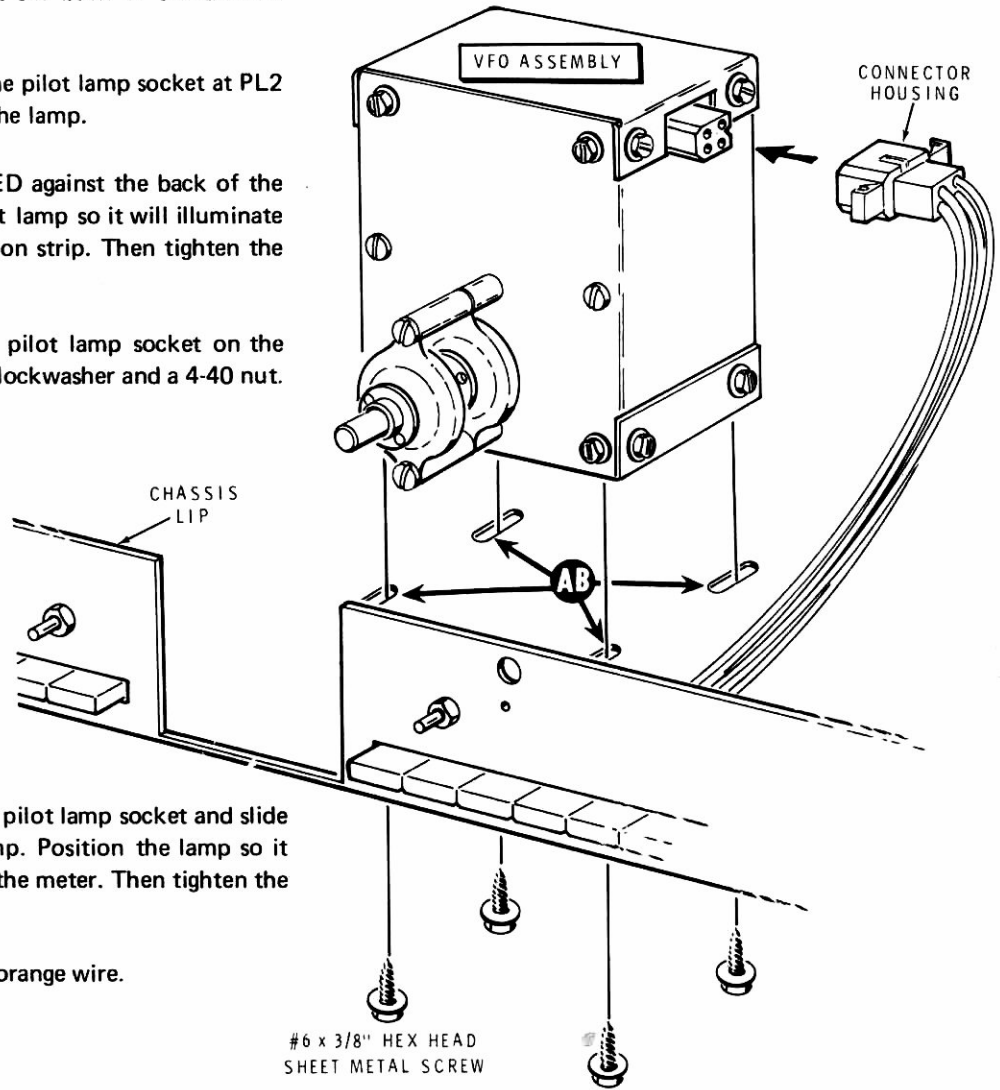

Detail 12-33A

- () Place a #1813 lamp in the pilot lamp socket and slide a light shield onto the lamp. Position the lamp so it will illuminate the back of the meter. Then tighten the nut.
- () Prepare a 6" gray and a 6" orange wire.

FRONT PANEL AND VFO MOUNTING

Refer to Pictorial 12-33 (Illustration Booklet, Page 14) for the following steps.

- () Refer to Detail 12-33A and install the VFO assembly at holes AB. Use #6 x 3/8" hex head sheet metal screws in the four slotted holes. Push the VFO as far away from the chassis lip as it will go before you tighten the screws.
- () Plug the 4-wire connector housing onto the 4-wire connector on the VFO.

NOTE: In some cases there may be excess paint on the inside of hole J1. Scrape off the excess paint only (do NOT remove any metal).

- () J1: Refer to Detail 12-33B and install the microphone panel connector at J1 on the front panel. Note the position of hole #1 (the number is molded into the face of the connector). Make sure the connector is positioned correctly and then tighten the large nut as much as possible so the serrations on the connector will form notches in the inside of the panel hole. Then temporarily remove the nut.
- () Temporarily remove the five nuts and three flat washers on the controls mounted on the chassis lip.

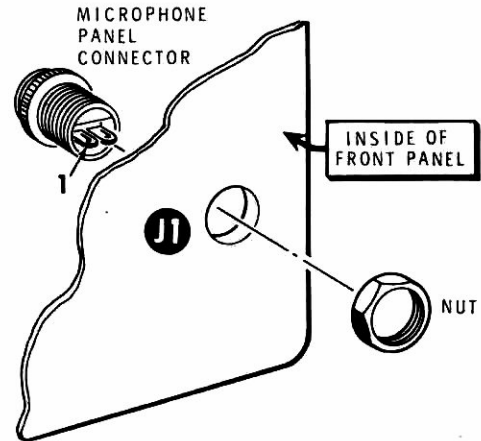

Detail 12-33B

Refer to Detail 12-33C for the next step.

- () Fit the front panel onto the control bushings and the pushbutton switches. Then replace the nuts and washers removed in the preceding step. Check for wires that might be pinched between the panel and chassis.
- () Secure the front panel to the left side panel at EU with 6-32 x 3/8" hardware.
- () Install a #6 x 1/2" hex head sheet metal screw through the left side panel to the chassis at BU.

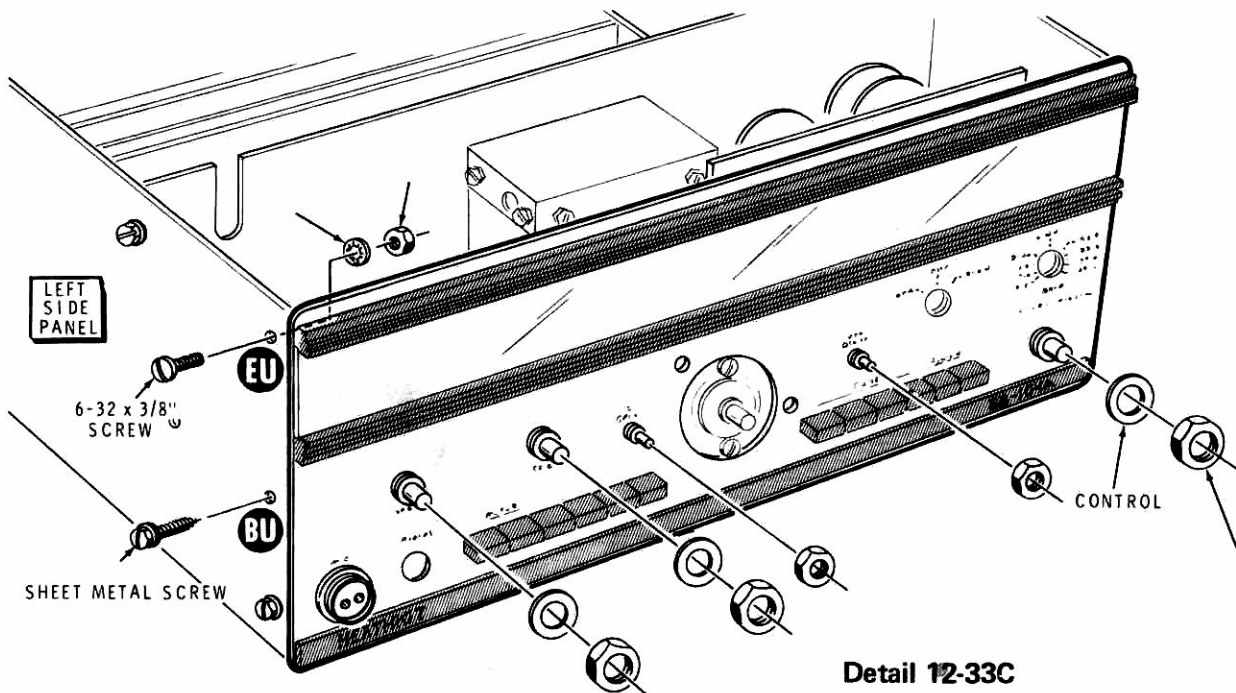

Detail 12-33C

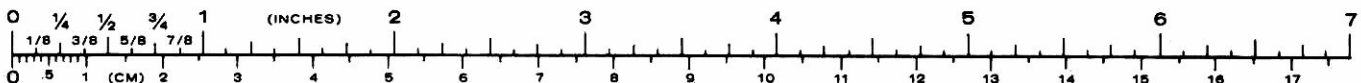

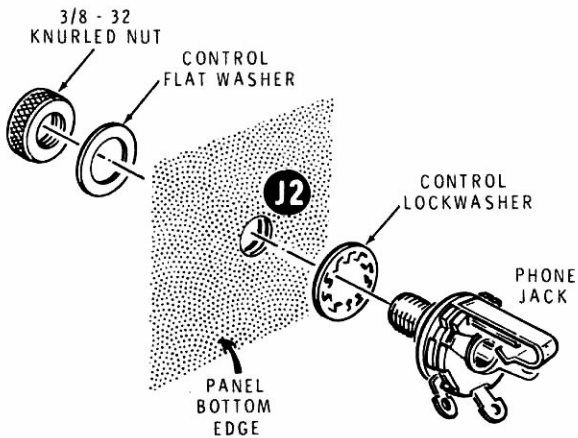

Detail 12-33E

- () Refer to Detail 12-33D (Illustration Booklet, Page 14) and place the lockwasher on the microphone connector. After the lockwasher is positioned, hold the nut against the back of the threads and turn the nut with the blade of a screwdriver as shown.
- () J2: Refer to Detail 12-33E and install a phone jack at J2. Use a control lockwasher, a control flat washer, and the 3/8-32 knurled nut. Use a rag under your pliers to avoid damaging the knurls on the nut.
- () Refer to Detail 12-33F and mount the 3-position switch detent (#266-1114) at S4 on the chassis lip. Be sure the locating tab is in its hole. Use a control flat washer and a control nut.

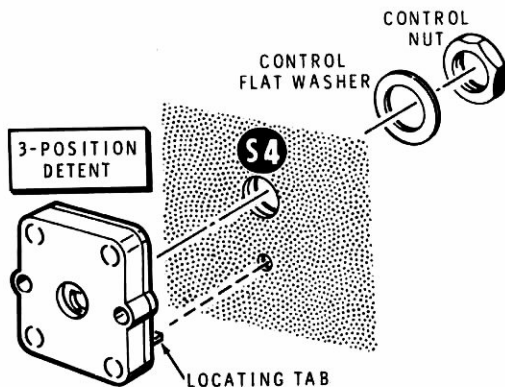

Detail 12-33F

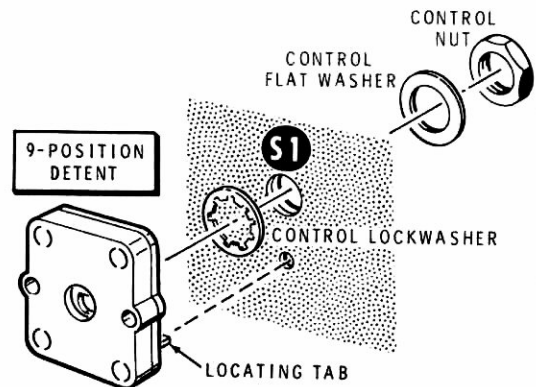

Detail 12-33G

- () Refer to Detail 12-33G and mount the 9-position detent (#266-1117) at S1 on the chassis lip. Use a control flat washer, a control lockwasher and a control nut.
- () Tighten all nuts on the front panel.
- () Connect the gray wire coming from lug 1 of control R9 to PL1 lug 2 (NS).
- () Connect the orange wire coming from Q2 to PL1 lug 1 (S-2).
- () Connect the gray wire coming from the "-" lug of the meter to PL1 lug 2 (S-3).
- () Connect the gray wire coming from switch S-2, section A, to the "+" lug of the meter (S-1).
- () Refer to Detail 12-33H and mount the display circuit board (#85-1416-1) on spacers at EH, EJ, EK, and EL. Be sure the display tubes are toward the red window. Use #4 lockwashers and the 4-40 nuts (#252-2) laid aside earlier. Start the nut at EJ by holding the nut against the end of the spacer with your finger and pushing against the corners of the nut with the blade of a small screwdriver.

NOTE: In the following steps the connectors on the wires at breakouts 14 through 18 will be pushed onto the pins on the display circuit board. The Details aid in matching the wires to the pins. Be sure to push the connectors straight down so the pins will not be bent.

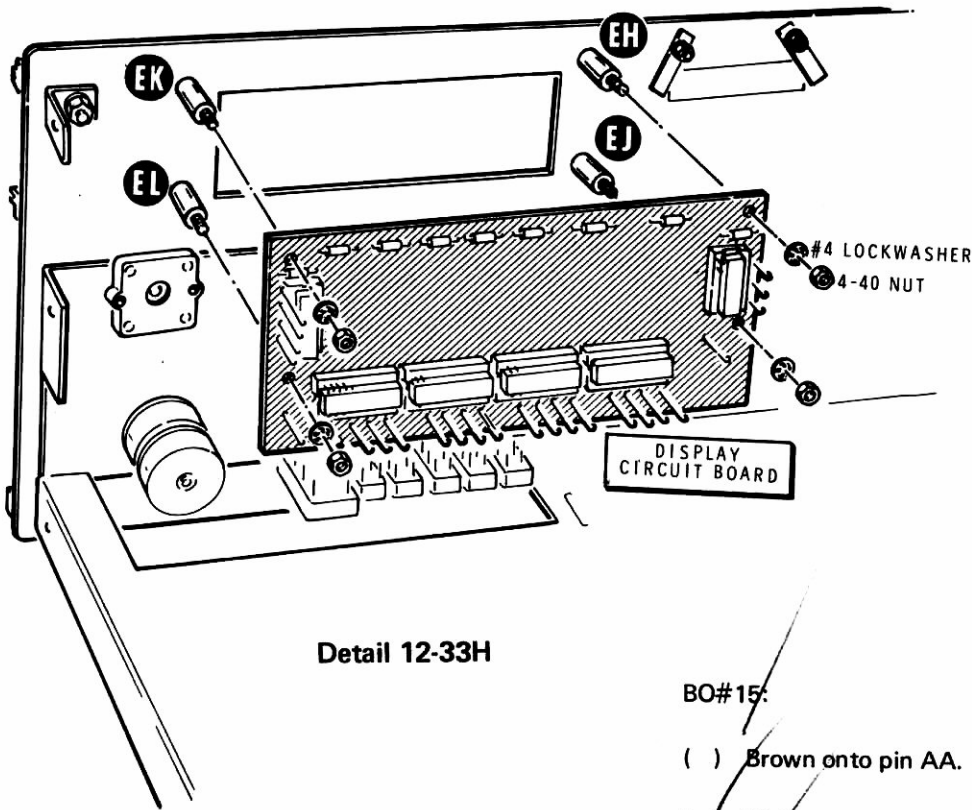

Detail 12-33H

BO#15:

- () Brown onto pin AA.
- (/) White-orange onto pin Y.

BO#14:

- (/) Black onto pin AE.
- (/) White-orange onto pin AC.

Refer to Detail 12-33J and push connectors onto the circuit board pins.

BO#18:

- (/) Short white-red wire onto pin F.
- (/) Short white-yellow wire onto pin H.
- () Orange onto pin B.
- () Long white-red onto pin D.

BO#17:

- (/) Green onto pin P.
- (/) White-orange onto pin L.

BO#16:

- (/) Yellow onto pin U.
- (/) White-orange onto pin S.

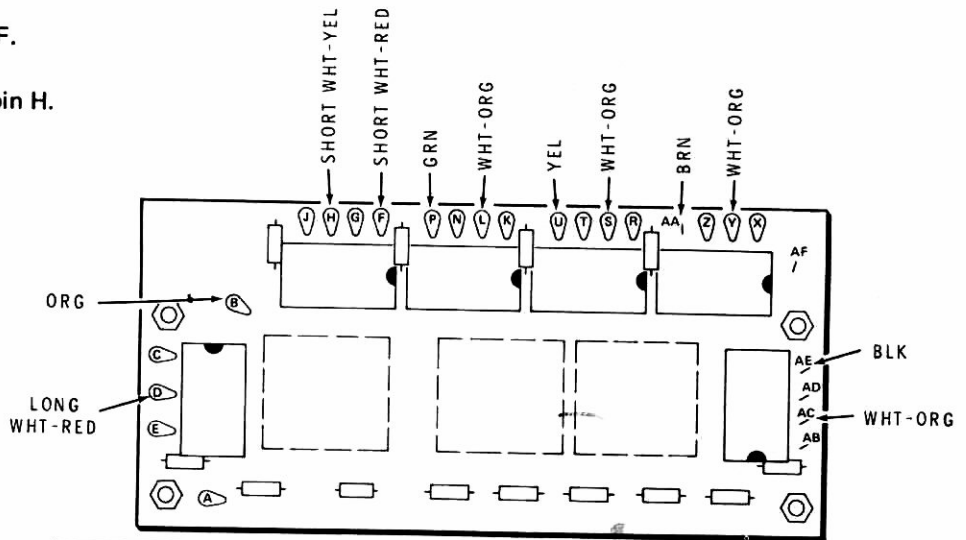

Detail 12-33J

TOP EDGE OF FRONT PANEL

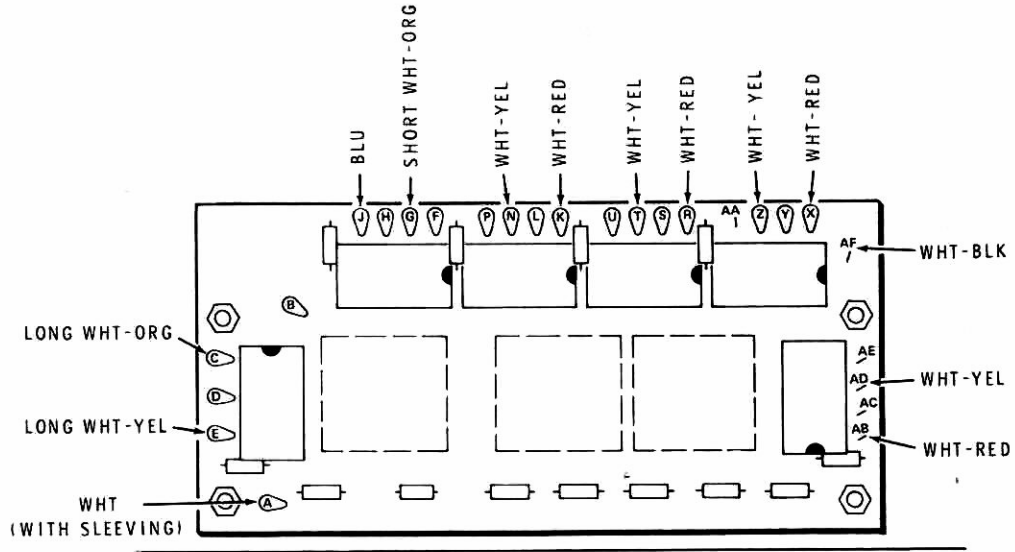

TOP EDGE OF FRONT PANEL

Detail 12-33K

Refer to Detail 12-33K and push connectors onto the circuit board pins.

BO#18:

() Short white-orange onto pin G.

- (/) Blue onto pin J.
- () Long white-orange onto pin C.
- () Long white-yellow onto pin E.

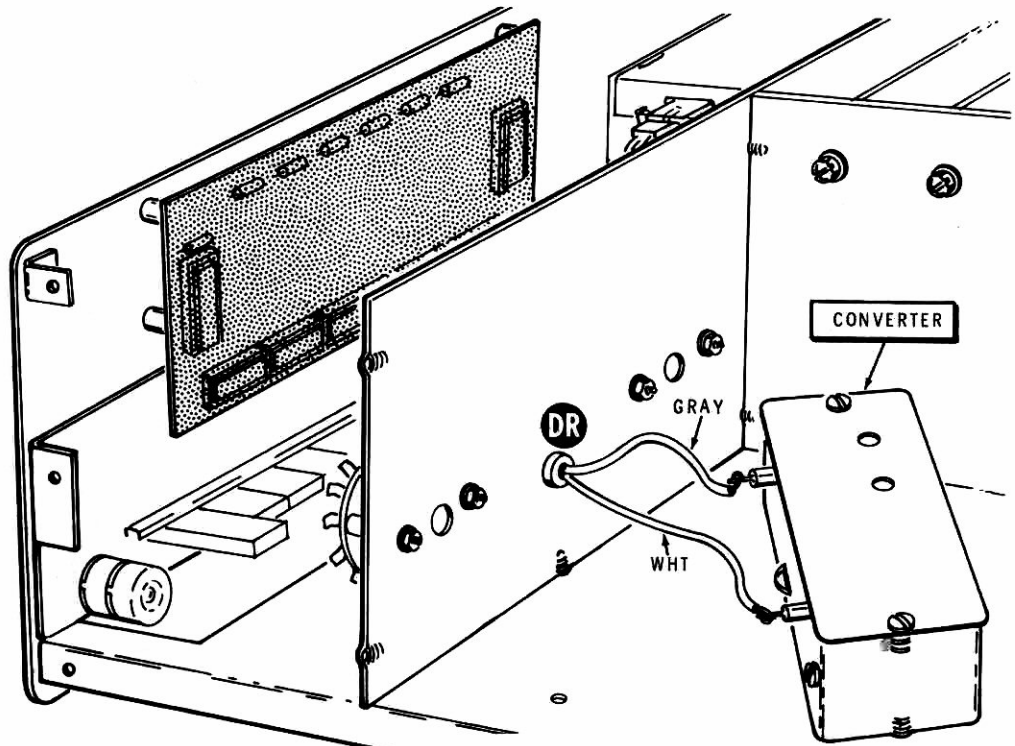

Detail 12-33L

- () Place a 3/4" length of fiber sleeving on the white lead and push the connector onto pin A. Then position the sleeving so it covers the pin and the connector on the wire.

BO#17:

- () White-yellow onto pin N.
- () White-red onto pin K.

BO#16:

- () White-yellow onto pin T.
- () White-red onto pin R.

BO#15:

- () White-yellow onto pin Z.
- () White-red onto pin X.
- () White black onto pin AF.

BO#14:

- () White-yellow onto pin AD.
- () White-red onto pin AB.

Refer to Detail 12-33L for the following steps.

NOTE: Because it is easier, the connecting wires will be connected to the converter terminals before the assembly is secured to the chassis.

- () Place the converter assembly on the chassis with the terminals toward grommet DR.
- () Connect the white wire and the gray wire coming from grommet DR to the terminals shown. Hook the end of each wire around its terminal and solder.
- () Secure the ALC/output filter shield and the converter assembly to the chassis with #6 x 1/2" hex head sheet metal screws at BG and BH. Be sure to position the shield as shown in the Pictorial.

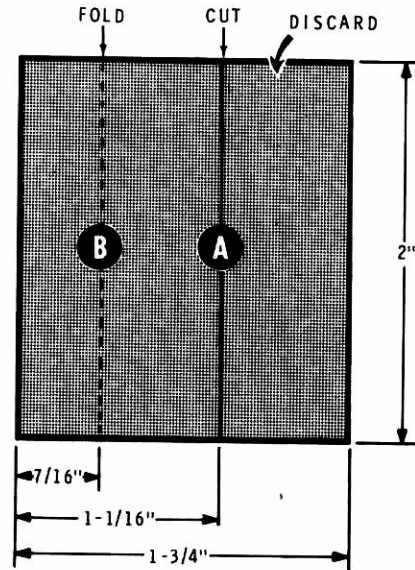

Detail 12-33M

Refer to full size Detail 12-33M for the following steps.

- () Mark off line A on a piece of 2 x 1-3/4" fish paper. Cut the paper along line A and discard the indicated piece.
- () Fold the pieces sharply together along line B so the two gray surfaces are together. When released, the two halves of the fish paper should form a right angle to each other.
- () Refer to Detail 12-33N, remove the protective covering of the fish paper, and position one adhesive side of the paper against the back of the front panel at the end of the display board to form a light shield. Rub the paper firmly against the panel.

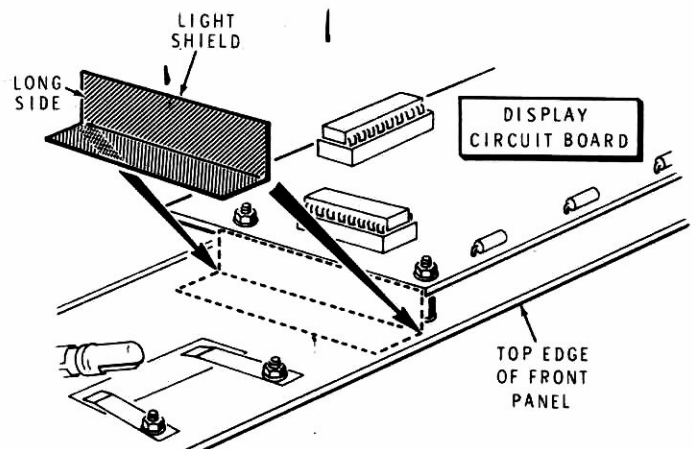

Detail 12-33N

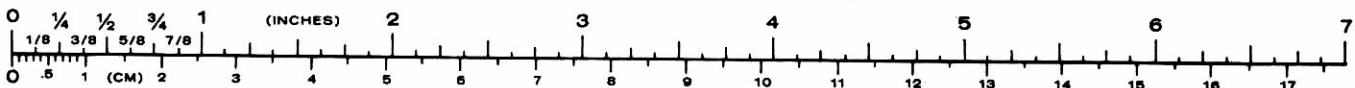

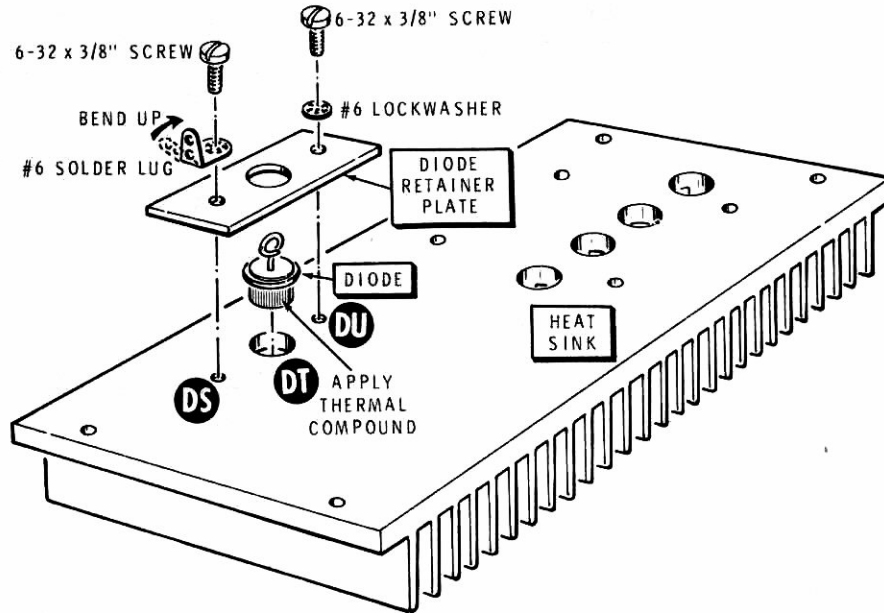

Detail 12-34A

Right Side and Diode Assembly

Refer to Pictorial 12-34 (Illustration Booklet, Page 15) for the following steps.

- () Mount the right side panel on the right side of the chassis. Use 6-32 x 3/8" hardware at EX, and #6 x 1/2" hex head sheet metal screws at GA, GB, GD, GE, GF and GL.
- () D1: Refer to Detail 12-34A and rub a heavy coating of thermal compound on the case of a 1N3491 diode (#57-34). Then place the diode in hole DT in the heat sink. Use a diode retainer plate, held in place by a #6 lockwasher and a 6-32 x 3/8" screw at DU and by a #6 solder lug and a 6-32 x 3/8" screw at DS. Bend the solder lug so it points straight out from the heat sink.
- () Bend a small circle at the end of the diode lead, as shown.
- () Mount the heat sink on the rear panel. Start two #6 x 3/4" hex head sheet metal screws at DA and DB and two #6 x 5/8" hex head sheet metal screws at DG and DJ. Push the heat sink toward the end of the rear panel as far as possible and tighten screws DA and DB. Then tighten screws DG and DJ.

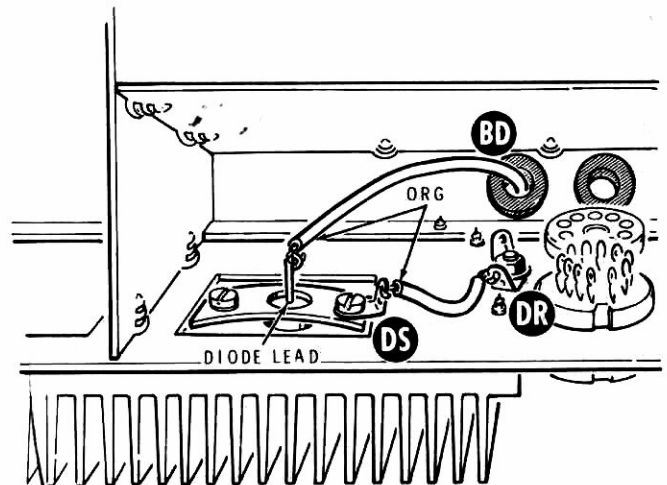

Detail 12-34B

- () Refer to Detail 12-34B and connect the orange wire coming from solder lug DR to the solder lug at DS (S-1).
- () Connect the orange wire coming from grommet BD to the diode lead (S-1).

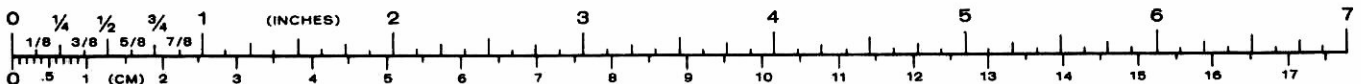

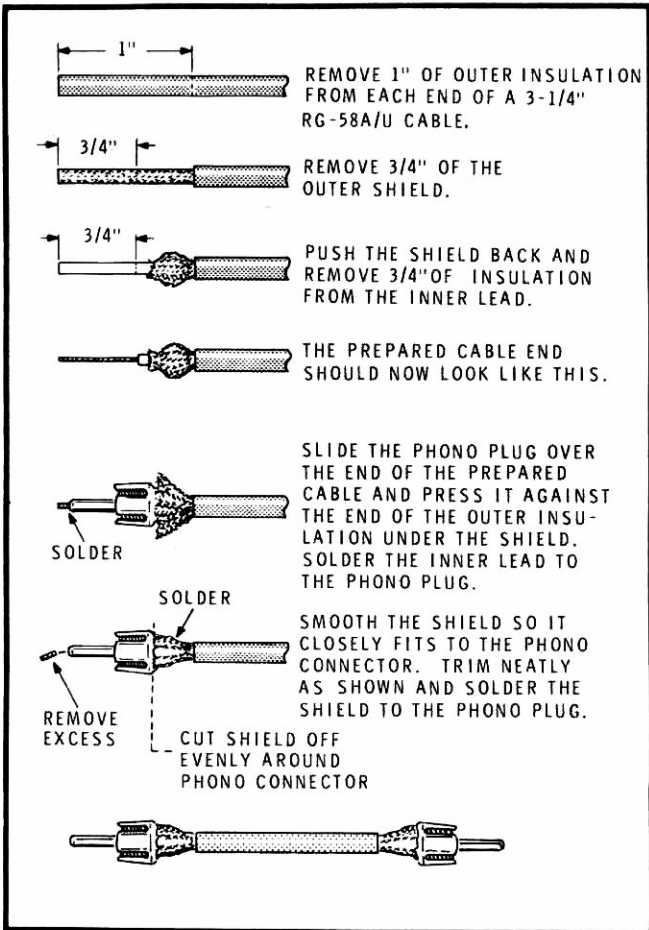

Detail 12-34C

- () Refer to Detail 12-34C and prepare the VFO jumper. Just before you solder the braid to the phono plugs, check with an ohmmeter to be sure no fine strands of the braid are causing a short circuit to the center conductor.
- () After the phono plugs are cool, bend the VFO jumper into a U shape and push the two phono plugs into the VFO IN and OUT phono sockets on the rear panel.

UNDER-CHASSIS PANEL WIRING

Refer to Pictorial 12-35 for the following steps.

- () Connect the blue wire coming from BO#11 to the microphone connector, lug 2 (S-1).
- NOTE: When you connect the cables in the next three steps, use 5/8" of small sleeving on each shield wire.
- () Connect the center conductor of shielded lead #11 to the microphone connector, lug 1 (S-1), and connect the shield wires to the phones jack, lug 1 (NS).
 - () Connect shielded lead #1 to the phones jack: the center conductor to lug 2 (S-1) and the shield wires to lug 1 (NS).
 - () Connect shielded lead #4 to the phones jack; the center conductor to lug 3 (S-1) and the shield wires to lug 1 (NS).
 - () C6: Connect the positive (+) lead of a 1000 μ F electrolytic capacitor to lug B of transistor Q2 (S-2), and connect the other lead to the phones jack at lug 1 (S-4).

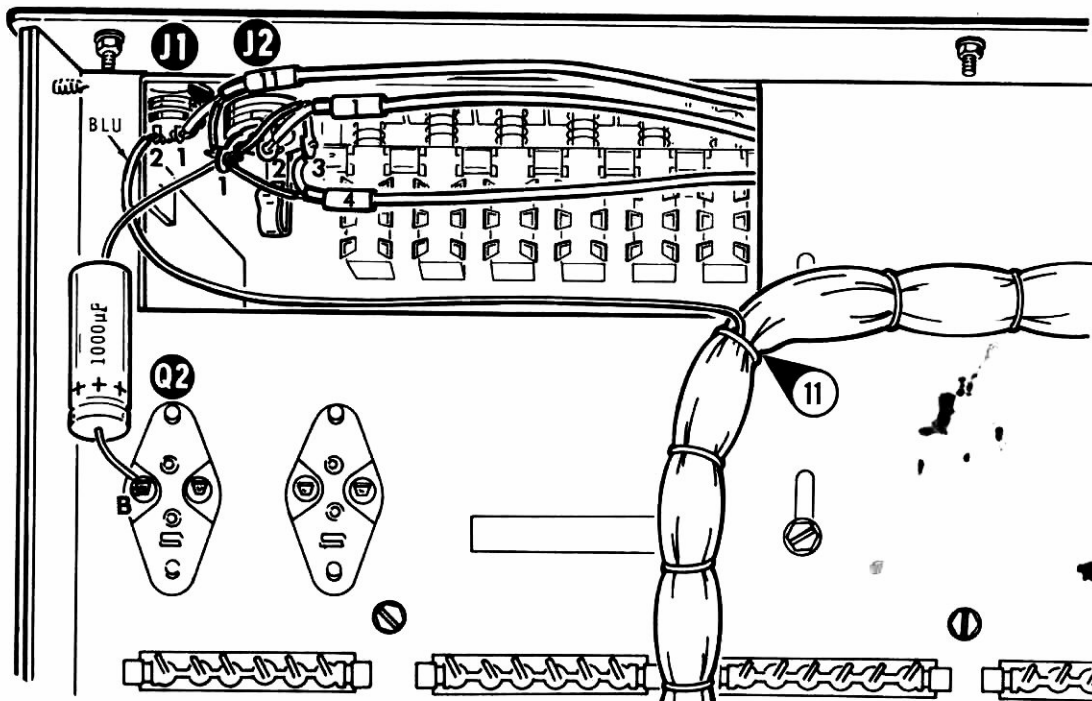

PICTORIAL 12-35

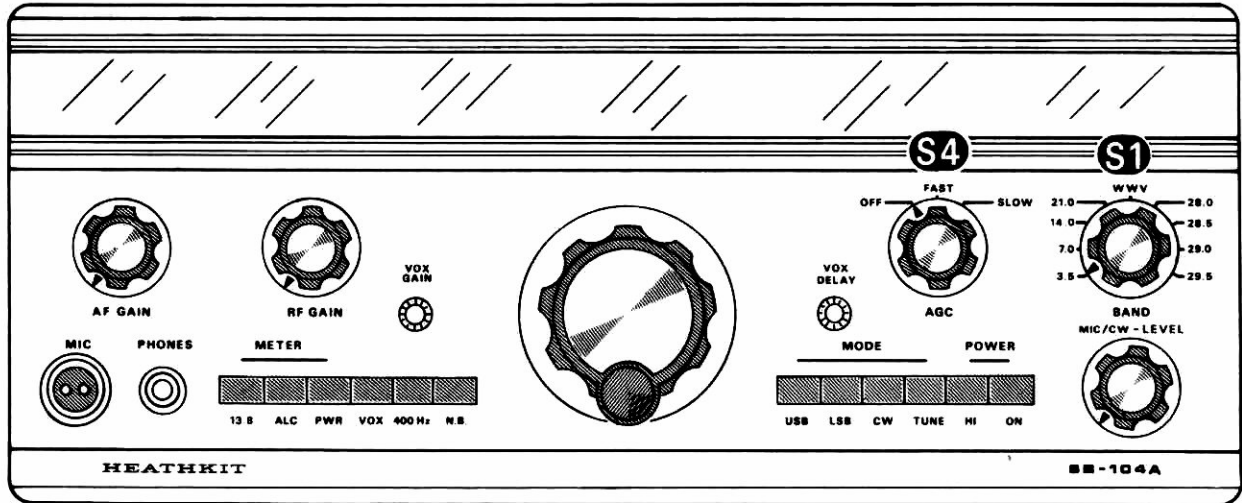

PICTORIAL 12-36

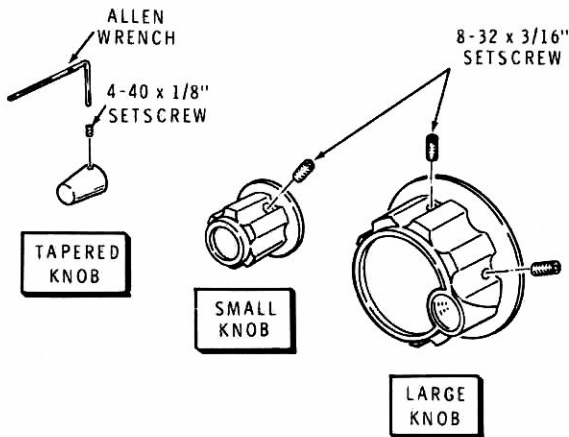

Detail 12-36A

KNOBS AND SHAFTS

Refer to Pictorial 12-36 for the following steps.

Refer to Detail 12-36A for the next two steps.

- () Start an 8-32 x 3/16" setscrew into each of five small knobs and start two setscrews into the large knob. (NOTE: The large knob may have allen head setscrews already installed).
- () Start a 4-40 x 1/8" setscrew into each of the two tapered knobs. Insert the end of the allen wrench into a setscrew and turn the wrench to start the setscrew.
- () Place the two tapered knobs on the shafts at Vox Gain and Vox Delay, and tighten the setscrews with the allen wrench.
- () Excepting the VFO (center) shaft, turn all of the front panel shafts fully counterclockwise.

- () Place the large knob on the VFO shaft and tighten one of the setscrews (this knob will be temporarily removed later). If necessary, readjust the position of the VFO.
- () Place three small knobs on the shafts at AF Gain, RF Gain and MIC/CW Level. Position the knob index marks as shown in the Pictorial and tighten the setscrews.

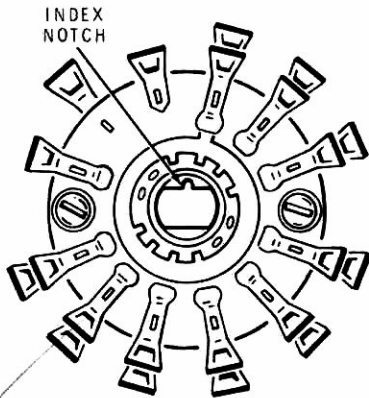

Detail 12-36B

- () Refer to Detail 12-36B and make sure both rotors of the switch at S1 are still positioned so the index notches are up.
- () Install a small knob on the 8" shaft. Make sure the setscrew tightens onto the flat on the knob end of the shaft.
- () Insert the 8" shaft not more than 1/2" through the detent on the panel at S1 (BAND). Turn the shaft and detent so the knob index mark will be at 3.5. Then push the end of the shaft on through the detent and just through the two switch wafers at S1 on the lateral shield. Be very sure the flatted sides of the shaft are aligned with the opening in the switch rotors before you apply any pressure, as the wafers can be damaged.

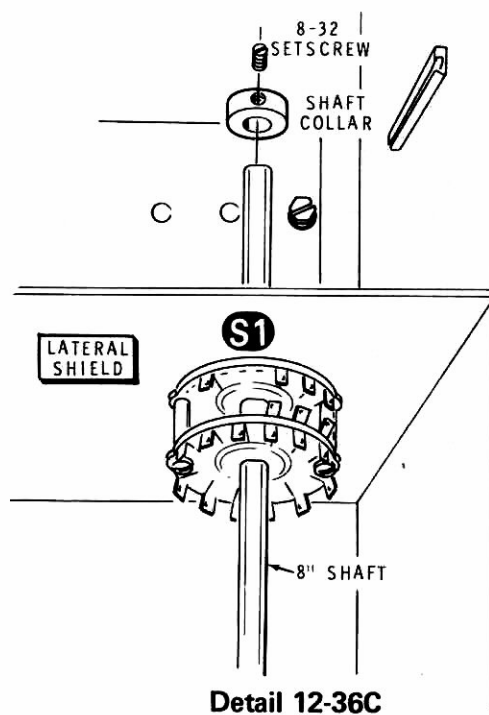

Detail 12-36C

- () Refer to Detail 12-36C and start an 8-32 setscrew into a shaft collar.
- () Slide the shaft collar onto the end of the 8" shaft so it is against the back side of the lateral shield. Push the shaft all the way in and tighten the setscrew just enough to prevent the collar from moving as the collar will be temporarily loosened later.
- () Install a 5" flatted shaft, shaft collar, 8-32 setscrew, and small knob at S4 (AGC). Turn the shaft fully counterclockwise and align the knob index mark at "off." Be sure to tighten the setscrew in the shaft collar.

NOTE: You will have several parts left over which will be used in the "Tests and Adjustments" and "Troubleshooting" sections of the Operation Manual.

Proceed to "Test and Adjustments" in the "Operation" Manual.

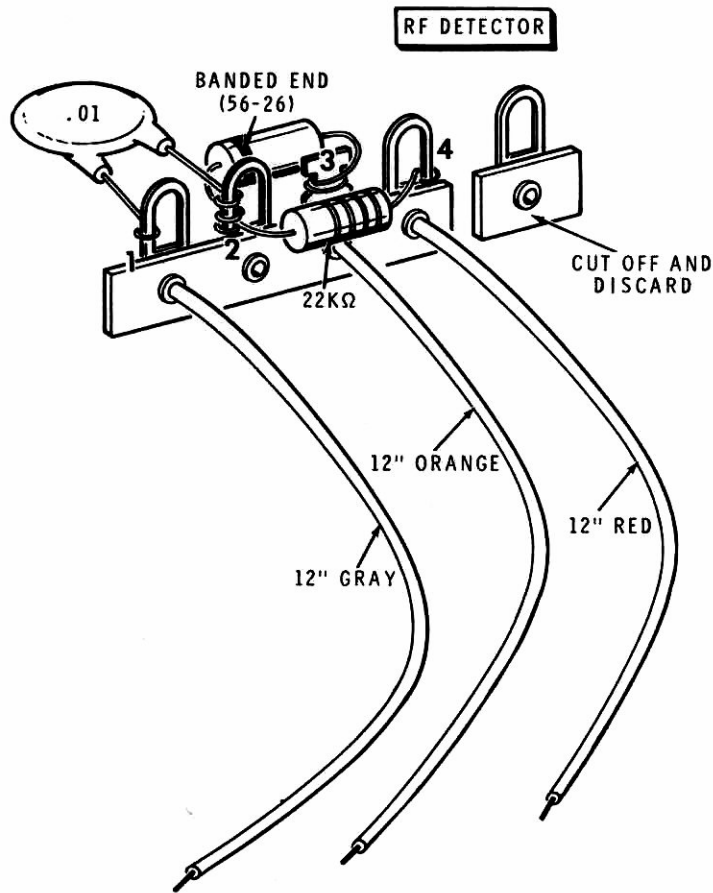

PICTORIAL 12-37

RF DETECTOR

Refer to Pictorial 12-37 for the following steps.

- () Cut off and discard the indicated lug from the terminal strip you laid aside earlier.
- () Connect a 22 kΩ (red-red-orange) resistor between lug 2 (NS) and lug 4 (S-1).

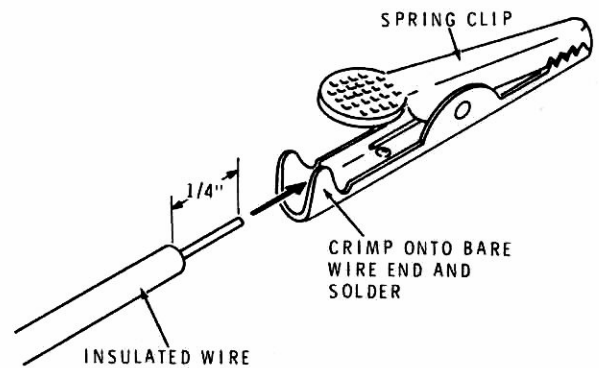

Detail 12-37A

- () Connect the lead at the banded end of a 1N191 diode (#56-26) to lug 2 (NS). Connect the other lead to lug 3 (S-1).
- () Connect a .01 μF disc capacitor between lug 1 (S-1) and lug 2 (S-3).
- () Connect a 12" gray wire to the lower hole of lug 1 (S-1).
- () Connect a 12" orange wire to the lower hole of lug 3 (S-1).
- () Connect a 12" red wire to the lower hole of lug 4 (S-1).
- () Refer to Detail 12-37A and connect three spring clips to the free ends of the three wires.
- () Lay the RF detector aside. It will be used later.

CUSTOMER SERVICE

REPLACEMENT PARTS

Please provide complete information when you request replacements from either the factory or Heath Electronic Centers. Be certain to include the **HEATH** part number exactly as it appears in the parts list.

ORDERING FROM THE FACTORY

Print all of the information requested on the parts order form furnished with this product and mail it to Heath. For telephone orders (parts only) dial 616 982-3571. If you are unable to locate an order form, write us a letter or card including:

- Heath part number.
- Model number.
- Date of purchase.
- Location purchased or invoice number.
- Nature of the defect.
- Your payment or authorization for COD shipment of parts not covered by warranty.

Mail letters to: Heath Company
Benton Harbor
MI 49022
Attn: Parts Replacement

Retain original parts until you receive replacements. Parts that should be returned to the factory will be listed on your packing slip.

OBTAINING REPLACEMENTS FROM HEATH ELECTRONIC CENTERS

For your convenience, "over the counter" replacement parts are available from the Heath Electronic Centers listed in your catalog. Be sure to bring in the original part and purchase invoice when you request a warranty replacement from a Heath Electronic Center.

TECHNICAL CONSULTATION

Need help with your kit? — Self-Service? — Construction? — Operation? — Call or write for assistance. you'll find our Technical Consultants eager to help with just about any technical problem except "customizing" for unique applications.

The effectiveness of our consultation service depends on the information you furnish. Be sure to tell us:

- The Model number and Series number from the blue and white label.
- The date of purchase.
- An exact description of the difficulty.
- Everything you have done in attempting to correct the problem.

Also include switch positions, connections to other units, operating procedures, voltage readings, and any other information you think might be helpful.

Please do not send parts for testing, unless this is specifically requested by our Consultants.

Hints: Telephone traffic is lightest at midweek — please be sure your Manual and notes are on hand when you call.

Heathkit Electronic Center facilities are also available for telephone or "walk-in" personal assistance.

REPAIR SERVICE

Service facilities are available, if they are needed, to repair your completed kit. (Kits that have been modified, soldered with paste flux or acid core solder, cannot be accepted for repair.)

If it is convenient, personally deliver your kit to a Heathkit Electronic Center. For warranty parts replacement, supply a copy of the invoice or sales slip.

If you prefer to ship your kit to the factory, attach a letter containing the following information directly to the unit:

- Your name and address.
- Date of purchase and invoice number.
- Copies of all correspondence relevant to the service of the kit.
- A brief description of the difficulty.
- Authorization to return your kit COD for the service and shipping charges. (This will reduce the possibility of delay.)

Check the equipment to see that all screws and parts are secured. (Do not include any wooden cabinets or color television picture tubes, as these are easily damaged in shipment. Do not include the kit Manual.) Place the equipment in a strong carton with at least **THREE INCHES** of *resilient* packing material (shredded paper, excelsior, etc.) on all sides. Use additional packing material where there are protrusions (control sticks, large knobs, etc.). If the unit weighs over 15 lbs., place this carton in another one with 3/4" of packing material between the two.

Seal the carton with reinforced gummed tape, tie it with a strong cord, and mark it "Fragile" on at least two sides. Remember, the carrier will not accept liability for shipping damage if the unit is insufficiently packed. Ship by prepaid express, United Parcel Service, or insured Parcel Post to:

Heath Company
Service Department
Benton Harbor, Michigan 49022



HEATH COMPANY • BENTON HARBOR, MICHIGAN
THE WORLD'S FINEST ELECTRONIC EQUIPMENT IN KIT FORM

LITHO IN U.S.A.