

SPECIFICATION MODEL CX-120P

IMPEDANCE/ 50 Ohms.

VOLTAGE

ACTUATION DATA :

VOLTAGE :

Pull in 10Vdc - 14Vdc (12Vdc Nominal)

Drop out 3.0Vdc Min.

Current 61mA @12Vdc 20°C

Coil resistance ... 196 Ohms 10% 20°C

SWITCHING TIME

SWITCHING TIME :

Pull in 20ms typical.

Drop out 15ms typical.

LIFE EXPECTANCY ... 1,000,000. Operation min.

MECHANICAL

MECAHANICAL :

Contact arrangement SPDT

Operational temperature - 25°C to + 50°C (Max Temperature Rise:20c)

Weight Approx 70gs.

Mounting Printed board only

ELECTRICAL CHARACTERISTICS

ELECTRICAL CHARACTERISTICS :

Frequency MHz	VSWR Max	Isolation -dB(min)	Ins.Loss -dB(max)	IN PUT
				RF Power W
50	1.05	60	0.05	250
150	1.1	50	0.1	200
500	1.3	40	0.2	150
1000	1.4	29	0.25	150

COIL CHARACTERISTICS

COIL CHARACTERISTICS :

Nominal Voltage
12Vdc

Voltage Range
10Vdc - 14Vdc

Coil Resistance Ohms
196 ±10% 20°C

Note : Other voltages are also available at option.

DIMENSIONS

SCALE m/n

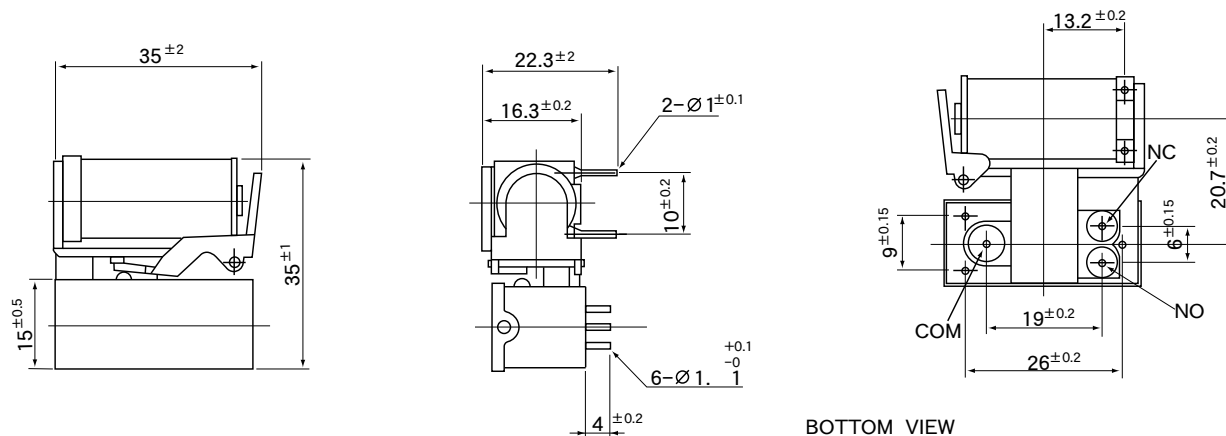

BOTTOM VIEW

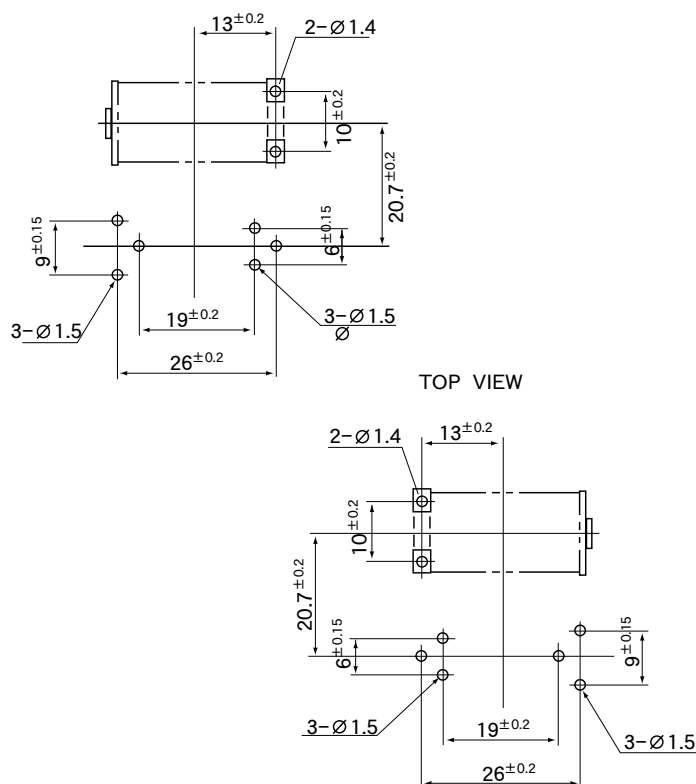

TOP VIEW

Typical Operating Curves

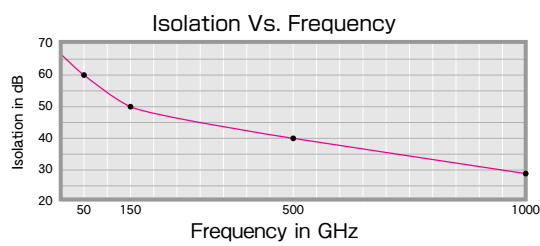
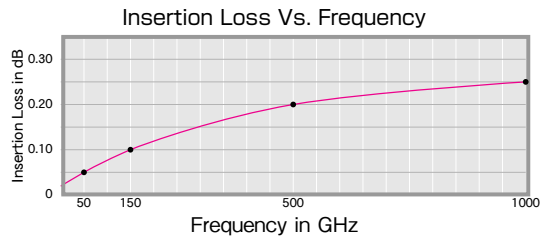
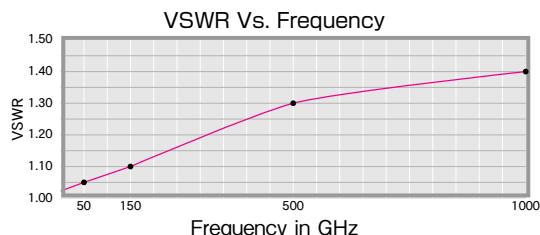

Schematic

