

CML Semiconductor Products

PRODUCT INFORMATION

FX315

CTCSS Encoder

Publication D/315/5 July 1994

Features/Applications

- 40 CTCSS Frequencies
- Field Programmable Tone Encoder
- Xtal Frequency Stability
- Low Distortion Sinewave Output
- Low Power 5 volt CMOS
- Surface Mount or DIL Package Style

Applications

- CTCSS Encode Applications
- Repeater Access Control
- Mobile or Hand Held Radio Squelch Control
- Low Frequency Tone Generation

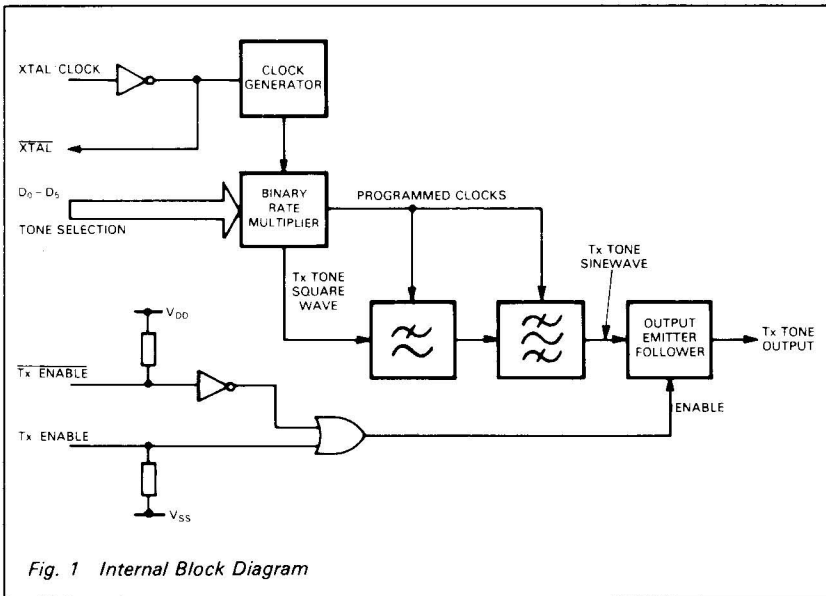

FX315

Brief Description

The FX315 is a monolithic CMOS integrated circuit tone encoder for sub-audio tone squelch systems. The tone frequencies are derived from an input reference frequency and an on-chip inverter is provided to drive an external crystal circuit.

Tone selection is by a logic code at the $D_0 - D_5$ programming inputs and two control inputs allow either a logic '1' or logic '0' to enable the device. A low distortion sinewave is generated at the Tx Tone Output when the FX315 is activated. The emitter follower output stage can source 1mW directly into a 600 Ohm load.

Pin Number

Function

DIL FX315J	Quad PX315LG	
1 2 3 4 5 6	1 2 5 6 7 8	<p>D₃ D₂ D₁ D₀ D₄ D₅ } Data Inputs:</p> <p>The logic combination at these inputs defines the CTCSS tone that the FX315 will encode (see Table 1). The input is not latched and can be changed at any time. A logic '1' will be programmed if the input is open circuit, allowing the use of SPST switches. Internal 1MΩ pull-up to V_{DD} per pin.</p>
7	11	<p>V_{SS}: Negative Supply.</p>
8	12	<p>Xtal/Clock: 1MHz Xtal input or externally derived clock can be injected here. Input to the on-chip inverting oscillator, at no time should supply voltage be applied without the input clock signal.</p>
9	13	<p><u>XTAL</u>: 1MHz Xtal output. Inverting output of the on-chip inverting oscillator. When used as a Xtal oscillator, track lengths and loading on the two oscillator pins should be minimised.</p>
10		<p>Internally wired. Leave open circuit.</p>
11	19	<p>T_x TONE OUTPUT: The output of a low impedance emitter follower tone output stage. The tone is generated about a d.c. level of V_{DD}/2. The pin is high impedance when not enabled.</p>
12	20	<p><u>T_x ENABLE</u>: A logic '0' input at this pin will force the device into tone encoding. Internal 1MΩ pull-up to V_{DD}.</p>
13	23	<p>T_x ENABLE: A logic '1' input at this pin will force the device into tone encoding. Internal 1MΩ pull-down to V_{SS}.</p>
14	24	<p>V_{DD}: Positive 5 volt supply.</p>
	<p>3.4.9.10 14.15.16. 17.18.21 22</p>	<p>Not connected.</p>

Application Notes

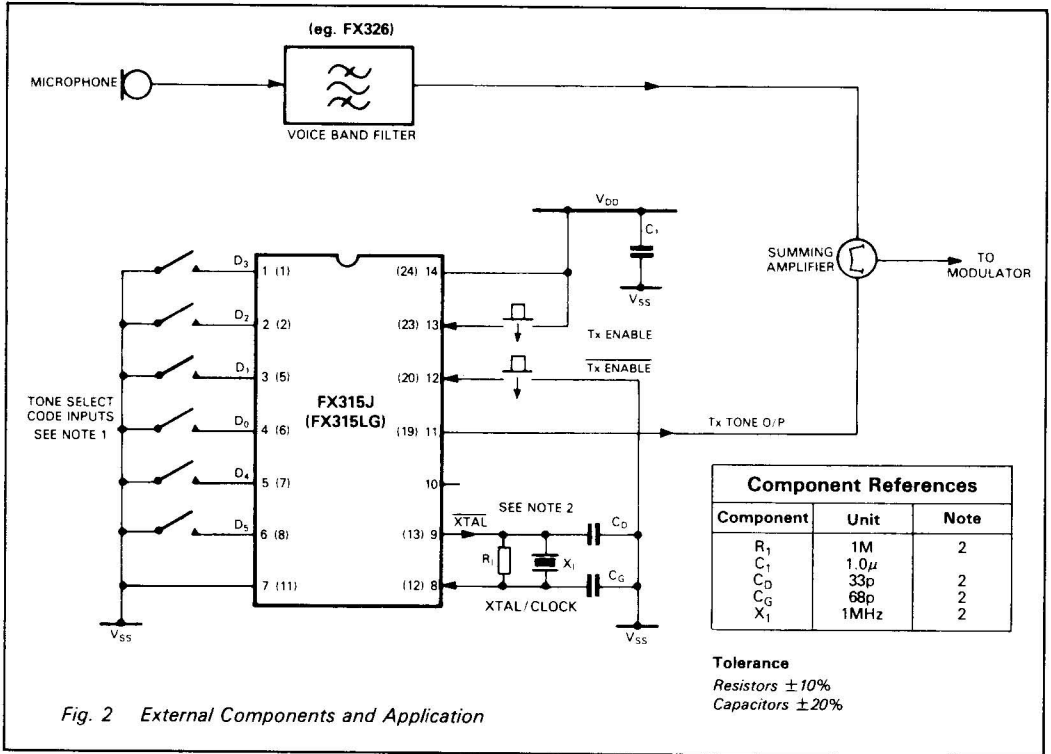

Notes:

- The FX315 'Tone Select' code inputs, left open circuit will be programmed with Logic '1's by the internal 1MΩ pull-up resistors. This enables the use of simple devices when coding. Wire links can be fitted for permanent code, SPST switches will allow code changes in the field. Using preformed coded 7-pin inserts will enable the user to communicate in predetermined groups.
- X₁ is a parallel resonant crystal. A reference frequency of 1 MHz ± 0.19% is required to maintain a tone accuracy within ±0.5%. Crystal circuitry shown in Figure 2 is in accordance with CML Application Note D/XT/1 April 1986. Where two or more circuits are required to use a single oscillator (eg. repeater applications), the signal at XTAL can be used to drive one additional Xtal/Clock input. Any further circuits can be driven from the buffered XTAL output of the second device.

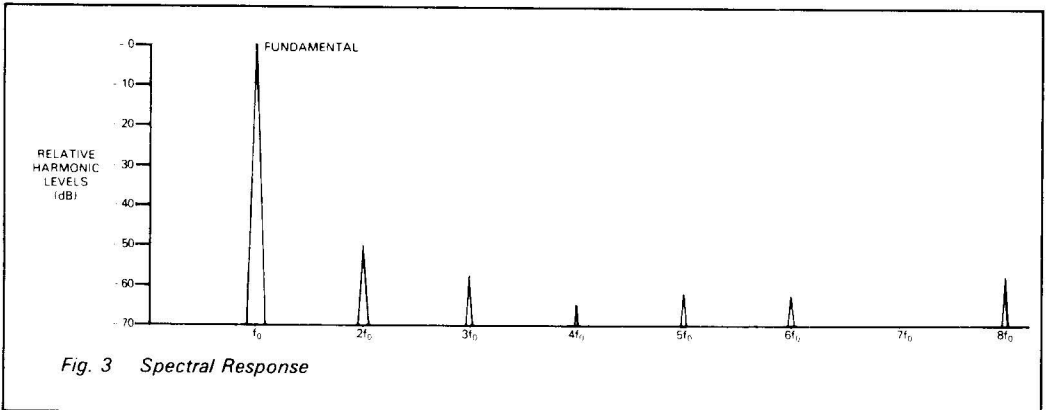

Application Notes

Nominal Freq. (Hz)	FX315 Freq. f_0 (Hz)	Δf_0 (%)	Programmable Inputs						Nominal Freq. (Hz)	FX315 Freq. f_0 (Hz)	Δf_0 (%)	Programmable Inputs					
			D ₀	D ₁	D ₂	D ₃	D ₄	D ₅				D ₀	D ₁	D ₂	D ₃	D ₄	D ₅
67.0	67.06	+0.10	1	1	1	1	1	1	131.8	131.67	-0.10	1	0	0	1	0	0
69.3	69.37	+0.10	1	0	0	1	1	1	136.5	136.69	+0.14	0	0	0	1	1	0
71.9	71.84	-0.08	1	1	1	1	1	0	141.3	141.48	+0.13	0	0	0	1	0	0
74.4	74.33	-0.10	0	1	1	1	1	1	146.2	145.96	-0.16	1	1	1	0	1	0
77.0	76.99	-0.02	1	1	1	1	0	0	151.4	151.45	+0.03	1	1	1	0	0	0
79.7	79.65	-0.06	1	0	1	1	1	1	156.7	156.59	-0.07	0	1	1	0	1	0
82.5	82.50	0.0	0	1	1	1	1	0	162.2	162.10	-0.06	0	1	1	0	0	0
85.4	85.34	-0.07	0	0	1	1	1	1	167.9	168.01	+0.07	1	0	1	0	1	0
88.5	88.62	+0.14	0	1	1	1	0	0	173.8	173.43	-0.21	1	0	1	0	0	0
91.5	91.38	-0.13	1	1	0	1	1	1	179.9	180.21	+0.17	0	0	1	0	1	0
94.8	94.88	+0.08	1	0	1	1	1	0	186.2	186.46	+0.14	0	0	1	0	0	0
97.4	97.46	+0.06	0	1	0	1	1	1	192.8	193.16	+0.19	1	1	0	0	1	0
100.0	99.87	-0.13	1	0	1	1	0	0	203.5	202.88	-0.31	1	1	0	0	0	0
103.5	103.39	-0.11	0	0	1	1	1	0	206.5	206.78	+0.14	0	0	0	1	1	1
107.2	107.17	-0.03	0	0	1	1	0	0	210.7	210.84	+0.07	0	1	0	0	1	0
110.9	110.85	-0.04	1	1	0	1	1	0	218.1	217.96	-0.07	0	1	0	0	0	0
114.8	114.80	0.0	1	1	0	1	0	0	225.7	225.58	-0.05	1	0	0	0	1	0
118.8	118.60	-0.17	0	1	0	1	1	0	233.6	233.75	+0.07	1	0	0	0	0	0
123.0	123.12	+0.10	0	1	0	1	0	0	241.8	242.54	+0.31	0	0	0	0	1	0
127.3	127.50	+0.16	1	0	0	1	1	0	250.3	250.06	+0.10	0	0	0	0	0	0
Test	4032	0.0	1	1	0	0	1	1									

Table 1 Code Programming Logic "1" = V_{D0} Logic "0" = V_{SS} Xtal Frequency (X_1) = 1.0MHz

General Notes

The FX315 is dedicated to continuous tone controlled squelch systems (CTCSS) in radio applications. It can however, be used wherever encoding of low frequency tones is required such as intercoms, door entry systems or industrial applications.

The performance of a CTCSS system can be degraded if speech frequencies in the signalling spectrum are not removed prior to transmission. This can be achieved by filtering the microphone signals to attenuate frequencies below 250Hz. Figure 2 illustrates adding the Tx Tone Output to the filtered microphone signals prior to modulation.

The FX315 requires a clock of 1MHz which is internally converted to logic level square waves. Consideration should therefore be given to possible interference problems with RF or IF circuitry caused by 1MHz or its harmonics (Fig. 3). A decoupling capacitor (C_1) should be used to smooth the supply rails. This will reduce the level of superimposed noise on the supply caused by internal switching transients (particularly at 1MHz and f_0).

Specification

Absolute Maximum Ratings

Exceeding the maximum rating can result in device damage. Operation of the device outside the operating limits is not implied.

Supply voltage		-0.3V to 7.0V
Input voltage at any pin (ref $V_{SS} = 0V$)		-0.3 to ($V_{DD} + 0.3V$)
Output sink/source current (supply pins)		$\pm 30mA$
(other pins)		$\pm 20mA$
Total device dissipation @ 25°C		800mW Max.
Derating		10mW/°C
Operating temperature range:	FX315J	-30°C to +85°C (Ceramic)
	FX315LG	-30°C to +70°C (Plastic)
Storage temperature range:	FX315J	-55°C to +125°C (Ceramic)
	FX315LG	-40°C to +85°C (Plastic)

Operating Limits

All characteristics measured using the following parameters unless otherwise specified:

$$V_{DD} = 5V, T_{amb} = 25^{\circ}C, \phi = 1MHz, R_L = 600\Omega, C_L = 15pF.$$

Characteristics	See Note	Min.	Typ.	Max.	Unit
Static Values					
Supply Voltage		4.5	5.0	5.5	V
Supply Current (Enabled)		—	1.5	—	mA
Logic Input Impedance		—	500	—	k Ω
Xtal Input Impedance		—	10	—	M Ω
Inputs Logic '1'	1	3.5	—	—	V
Inputs Logic '0'	1	—	—	1.5	V
Dynamic Values:					
Tone Output Level		-3	0	—	dBm
Tone Accuracy (f_0 error)		—	—	± 0.31	% f_0
Total Harmonic Distortion	2	—	2	5	%
Tone Output Load Current		—	—	5	mA
Tone Output Rise Time (t_R)		—	1	—	ms
Tone Level Variations		—	0.1	—	dB
Output Harmonic Attenuation		-49	—	—	dB

- Notes:**
1. Relate to all inputs.
 2. T.H.D. measurements taken in the 0–6kHz bandwidth.
 3. Output Loading: Large capacitive loads could cause the output pins of this device to oscillate. If capacitive loads in excess of 200 pF are unavoidable a resistor of typically <100 Ω put in series with the load should minimize this effect.

Package Outlines

The FX315 is available in the package styles outlined below. Mechanical package diagrams and specifications are detailed in Section 10 of this document.

Pin 1 identification marking is shown on the relevant diagram and pins on all package styles number anti-clockwise when viewed from the top.

Handling Precautions

The FX315 is a CMOS LSI circuit which includes input protection. However precautions should be taken to prevent static discharges which may cause damage.

FX315J 14-pin cerdip DIL (J1)

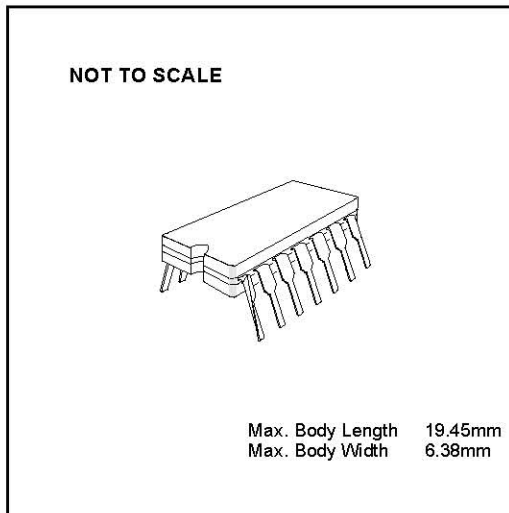

FX315LG 24-pin quad plastic encapsulated bent and cropped (L1)

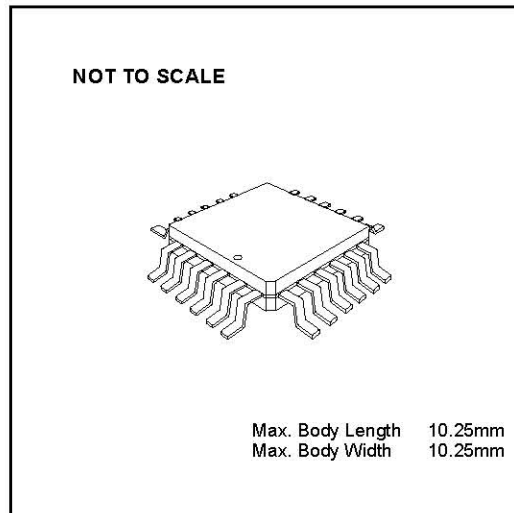

Ordering Information

FX315J 14-pin cerdip DIL (J1)

FX315LG 24-pin encapsulated bent and cropped (L1)