

Clegg

15 WATT 2 METER FM TRANSCEIVER

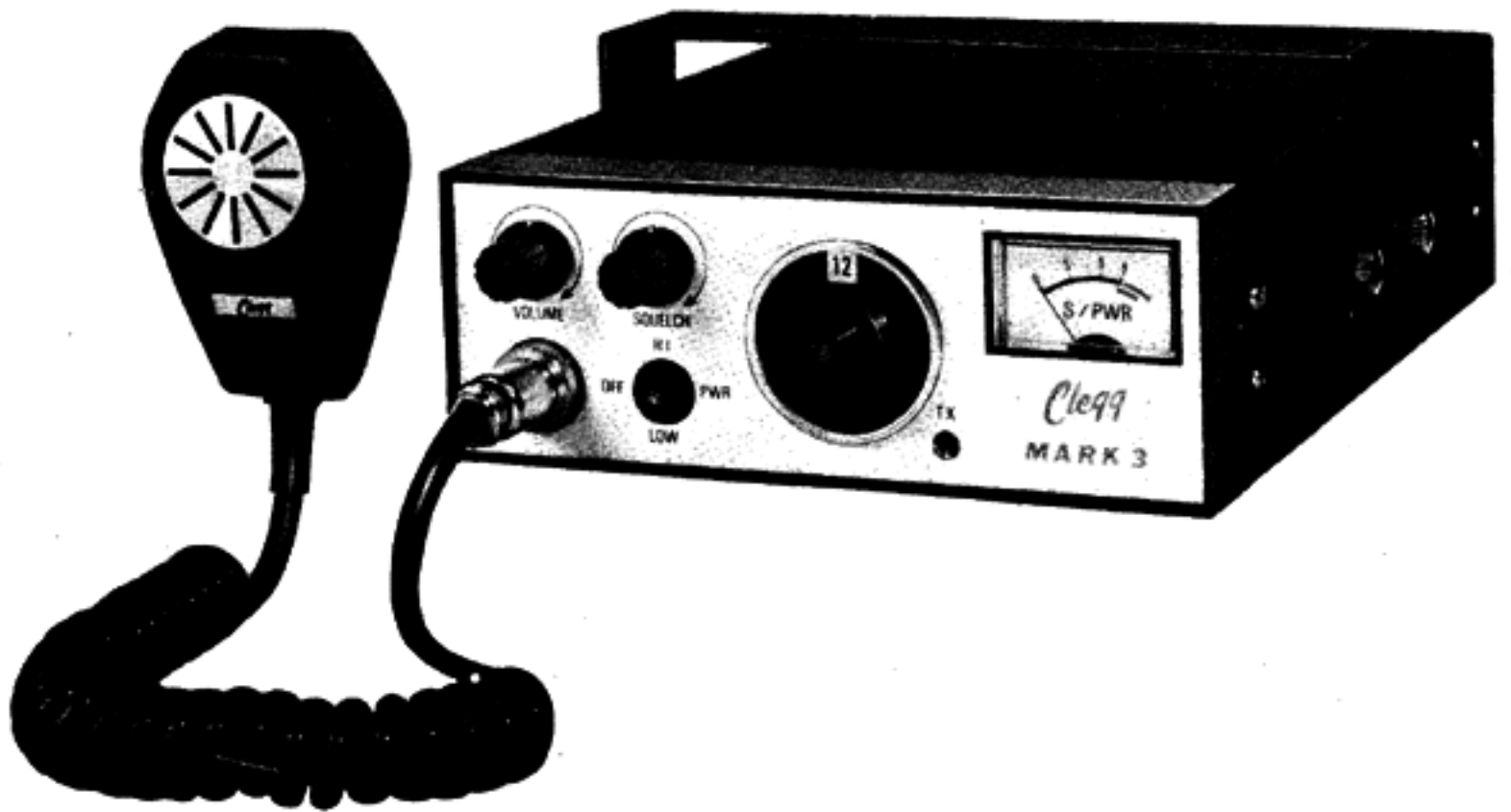

MARK 3

OWNER'S MANUAL

SECTION I SPECIFICATIONS

GENERAL:

Frequency coverage	144.00 to 148.00 MHz	
Number of Transistors	Transistors	33
	FET	3
	IC	2
	Diodes	18
Modulation Type	F3	
Power Voltage	DC 13.8V \pm 15% negative ground	
Current Drain	Transmit:	
	HI (15W) average	3.2A
	LOW (1W) average	1.0A
	Receive: average	150mA
Antenna Input	50 ohms	
Size	2-1/4" (H) x 6-3/8" (W) x 8-7/8" (D)	
Weight:	4-1/2 lbs.	

TRANSMITTER:

RF Power Output	HI	15W
	LOW	1W
Frequency Control	Crystal (12MHz) multiplied x 12	
Maximum Frequency Deviation	Adjustable between 3 to 16 kHz	
Audio Input	10K ohms	
Modulation System	Variable reactance phase modulation	
Microphone	10K ohms-Dynamic microphone with push button switch.	

RECEIVER: Certified to comply with FCC part 15.

Reception Frequencies	12 channels for 146 MHz band
	Built-in crystal units for 3 channels
Reception System	Double Superheterodyne
Intermediate Frequencies	1st IF: 10.7 MHz
	2nd IF: 455 kHz
Sensitivity	a. Better than 0.5 μ V 20 dB quieting
	b. S + N/N at 0.5 μ V input, 12 dB or more
Spurious Response	-55 dB
Squelch Threshold	Less than 0.3 μ V
Band width	\pm 5 kHz / -6 dB point
	\pm 12 kHz / -50 dB
Audio output power	2.5W
Audio output impedance	8 ohms
Frequency control	Crystal (45 MHz) multiplied x 3

ACCESSORIES:

The following accessories for the Clegg MARK 3 are included:

1. Microphone (dynamic type)	1	7. Instruction Manual	1
2. Microphone hanger	1	8. External speaker plug	1
3. Spare fuse (3A)	2	9. 4 prong plug for Tone Burst	
4. Mounting brakcet	1	Generator and Discriminator	
5. Mounting bracket studs	4	Meter	1
6. Channel frequency ID card	1	10. Crystals installed	
7. Instruction Manual	1	CH. 1 146.52/146.52 SIMPLEX	

SECTION II DESCRIPTION

The Clegg MARK 3 is an extremely rugged, completely solid state transceiver. Electrical design, mechanical construction and component selection assure reliable, high quality performance.

The compact, low profile packaging and convenient mobile mounting bracket facilitates convenient mounting in any vehicle. The clean, simple panel layout provides for ease of operation.

Although the MARK 3 has been designed principally for mobile operation its attractive appearance and electrical performance suit it admirable for base station operation with an external power supply. The large S meter enhances beam orientation; the excellent front end selectivity provides good immunity from cross modulation.

The dual conversion receiver with its FET front end and high-Q helicalized cavity resonators produce sensitivity of 0.5 μ V or less. Signal gain of 90 dB or more is accomplished from the second mixer back by virtue of 3 stage of IF amplifier (1 transistor and 2ICs). The need for additional front end RF amplification is thus eliminated. Zener regulated crystal-controlled first and second local oscillators produce unmatched stability. Audio reproduction is of an unusually high order of distortion free clarity.

The transmitter section will produce a nominal of 15 watts RF output. Again, a zener regulated crystal oscillator is employed for initial frequency stability. Twelve crystal controlled channels are provided for operating convenience and versatility. High-Q and shielded stages provided minimum interstage spurious reaction. An encased low pass filter is placed at the output to further insure undesirable frequency products not being emitted. An ingenious final PA transistor protection device (APC), is incorporated in the final output circuitry. A tiny VSWR bridge and four DC amplifiers constantly monitor the output for high VSWR, a shorted or absent antenna load or other difficulty that would cause irreparable final transistor damage. Should these difficulties occur, the APC instantaneously disables the driver and final PA without damage.

All circuitry is constructed in a series of modules which are easily removable for servicing.

Each unit comes complete with built-in speaker, a high-quality dynamic microphone, mobile mounting bracket, microphone hanger, and operating manual.

SECTION III INSTALLATION

3.1 Unpacking:

Carefully remove your transceiver from the packing carton and examine it for signs of shipping damage. Should any shipping damage be apparent, notify the delivering carrier immediately stating the full extent of the damage. It is recommended you keep the shipping carton. In the even storage, moving, or reshipment becomes necessary, they come in handy. Accessory hardware, cables, etc. are packed with the transceiver. Make sure you have not overlooked anything.

3.2 Location:

Where you place the transceiver in your automobile is not critical and should be governed by convenience and accessibility entirely. Since the unit is so compact, many mobile possibilities present themselves. In general, the mobile mounting bracket will provide you with some guide as to placement. Any place where it can be mounted with metal screws, bolts, or pop-rivets will work.

3.3 Power Requirements:

The transceiver is supplied ready to operate from any regulated 13.8V DC, 3.2 ampere negative ground source automobile, 12 volt, negative ground, system is usually more than adequate. Some note must be taken, however, to the condition of the vehicle's electrical system. Problems such as low battery, worn generator/alternator, poor voltage regulator, etc., will impair operation of your transceiver as well as the vehicle.

High noise generation or low voltage delivery can be traced to these deficiencies. If an AC power supply is used with your transceiver, make certain it is adequately regulated for both voltage and current. Low voltage while under load will not produce satisfactory results from your transceiver. Receiver gain and transmitter output will be greatly impaired.

CAUTION: Excessive Voltage (above 16VDC) will damage to your transceiver. Be sure to check the source voltage before connecting the power cord.

Included with your transceiver is a DC power cable. The red wire positive (+), and the black wire is negative (-). If your mobile installation permits, it is best to connect these directly to the battery terminals. The arrangement eliminated random noise and transient spikes sometimes found springing from automotive accessory wiring. If such an arrangement is not possible, then any convenient B+ lead in the interior of the vehicle and the negative from can be utilized. Your transceiver provides an internal DC filter that will take out the large amount of transient difficulties anyway. Remember, the unit operates on a negative ground system only—it cannot be used in a positive ground automobile.

If an AC power supply is used with your transceiver, make certain it is adequately regulated for both voltage and current. Low voltage while under load will not produce satisfactory results from your transceiver. Receiver gain and transmitter output will be greatly impaired.

3.4 Antenna:

The most important single item that will influence the performance of any communication system is the antenna. For that reason, a good, high-quality, gain antenna of 50 ohms impedance is recommended.

When adjusting your antenna, whether mobile or fixed, by all means follow the manufacturer's instructions. There are some pitfalls to be aware of. For example: do not attempt to adjust an antenna for lowest VSWR when using a diode VSWR meter not engineered for VHF applications. Such readings will invariably have an error of 40% or more. Rather, use an in-line watt meter similar to Bird Model 43 VHF cartridge. Further, when adjusting a mobile antenna, do so with the motor running preferably above normal idling speed. This will insure proper voltage level to the transceiver.

Trimmers have been placed on the crystal board to assist you in adjusting new crystals on frequency. Consult the trimmer location chart (Fig. 1) for their positions.

The amount of frequency spread between any two receiving or any two transmitting frequencies should not exceed 2 MHz. Since the receiver and transmitter are independent of each other, you may have any practical amount of frequency separation you wish here. Only two or more widely spaced frequencies for the receiver alone or for the transmitter alone need be considered under the 2 MHz limitation.

3.7 External speaker jack and plug is supplied with your unit in the event another speaker is desirable. The external speaker impedance should be 8 ohms. The use of external speaker jack will disable the internal speaker. An 8 ohm headset can be utilized as well.

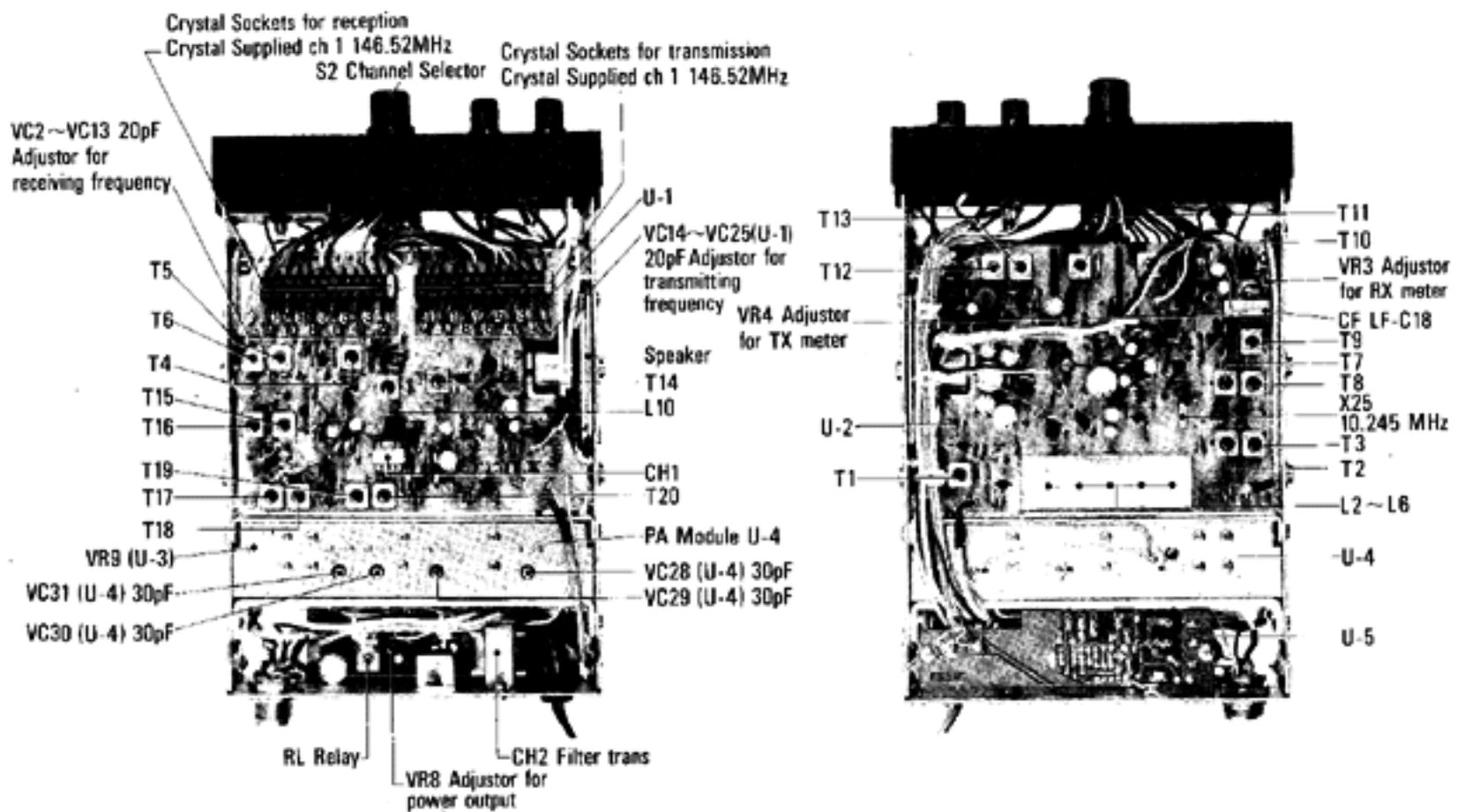

FIG. 1

SECTION IV CONTROL FUNCTIONS

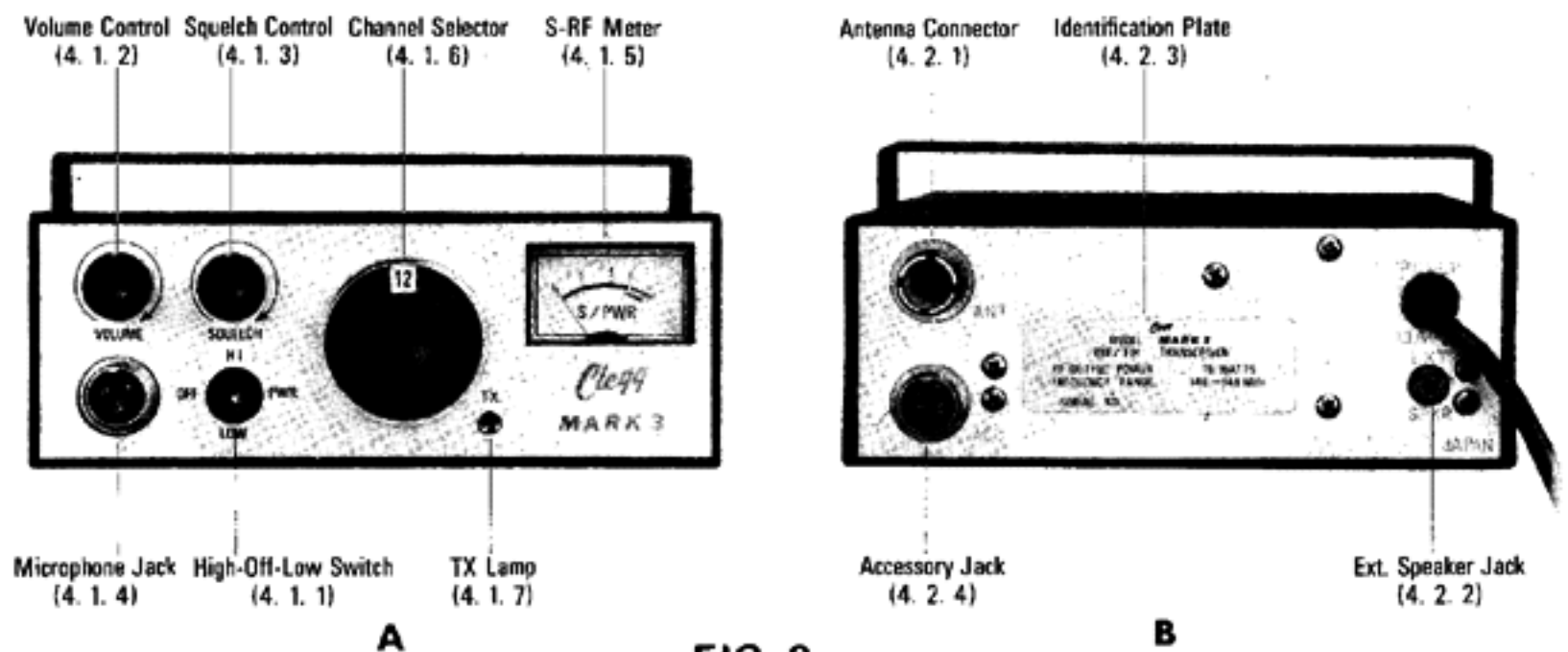

FIG. 2

- 4.1 Front control and jack (Fig. 2-A)
 - 4.1.1 High-Off-Low switch: opens or closes the 13.8 VDC source voltage to the transceiver. In "high" position, output power is 15 watts. In "low" position output power is 1 watt.
 - 4.1.2 Volume Control: controls audio output level of the receiver.
 - 4.1.3 Squelch Control: controls the squelch threshold point of the receiver.
 - 4.1.4 Microphone Jack: accepts 3 prong mike plug supplied on microphone.
 - 4.1.5 S-RF Meter: read S signal strength in receive mode and relative RF output in transmit mode. The meter face is illuminated with a white lamp when the transceiver is switched on in-receive condition.
 - 4.1.6 Channel Selector: selects one of twelve pairs of transmit receive crystals.
 - 4.1.7 TX Lamp: Comes on when microphone PTT button is pressed and transmitter is on the air.
- 4.2 Rear Panel (fig. 2-B)
 - 4.2.1 Antenna Connector: Accepts standard PL-259 coaxial connector. Note: Some transceivers may come with a metric threaded connector. If this is the case, a mating metric PL-259 is supplied also. Most PL-259 connectors will mate satisfactorily if care is taken to seat them properly. If you have difficulty, try a different make of PL-259.
 - 4.2.2 External Speaker Jack:
This jack mates with the accessory Ext. Speaker Plug supplied for external 8 ohm speaker or headset use. The use of this jack mutes the internal speaker.
 - 4.2.3 Identification Plate:
States model, serial number, RF output power and frequency range. Note: It would be well to make a separate record of the serial number of your unit for insurance purposes.
 - 4.2.4 Accessory Jack:
Accepts accessory 4 Prong Plug supplied for tone-burst and discriminator meter.
It would have as connections:
 - 1. Tone audio input (10mV)
 - 2. 12 volt negative (ground)
 - 3. Transmit keyed 12 VDC positive
 - 4. Discriminator meter connection (See Section 7-2-d)

SECTION V OPERATION

- 5.1 Initial Preparations:
 - a. Connect the microphone to the microphone jack.
 - b. Connect the antenna to the antenna coax connector. Make sure the coax line is of the correct impedance (50 ohms) and is neither shorted nor open circuited.
 - c. Make sure the function switch is in the off position. The red lead should be connected to the positive side of the power source and the black lead to the negative side. In the event that these leads are improperly connected, the MARK 3 will not function. No damage will be incurred since protection is provided for this purpose.
 - d. Turn the volume and squelch controls to the maximum counter clockwise position.

- 5.2 Operation:
- When the function switch is set to either the "HI" or "LOW" position, the set is switched on, and the channel indicator window and meter will be illuminated.
 - Switch the channel selector to the desired channel.
- 5.3 Reception:
- Adjust the volume control to a comfortable listening level of noise, if no signal is present.
 - Carefully adjust the squelch control clockwise until the noise just disappears. This is the proper squelch threshold setting and must be done when no signal is received which opens the squelch. If the squelch is unstable due to the reception of weak or unstable stations, adjust the squelch control further until the proper threshold is obtained.
 - The S meter indicates the signal strength of the incoming stations and is calibrated in S units. An input signal of approximately $5\mu\text{v}$ will provide an S9 reading.
- 5.4 Transmitting:
- Push the PTT (push to talk) button on the microphone and the transceiver is set for transmitting. At the same time, the TX Lamp is illuminated and the meter provides an indication of relative power output of the transmitter. The pointer will be on or near the red mark on the meter scale when on high power and just a little over one on low power.
 - Hold the microphone about three inches from your mouth and speak in a normal voice. Shouting does not increase your communication range, but a good antenna does. The microphone is of the dynamic type and provides good pickup for all levels of the voice.
 - To receive again, just release the PTT button. This will also switch off the red illumination of the Lamp.
- 5.5 Function Switch:
- You can select the proper output power according to the communication distance to be covered or conditions. When using the MARK 3 as a driver or exciter for an amplifier, the function switch can be set to the low power position and the power output adjusted as described in the Power Supply section. This will provide the required amount of drive for the linear amplifier without wasting power in swamping resistors, etc. When the switch is set on "HI", the power output will be 15 watts; on "LOW" the output will be 1 watt.

SECTION VI THEORY OF OPERATION

- 6.1 Receiver RF Amplifier and First Mixer Module U-2 (124-201-02). The input signal is amplified by the field effect cascade amplifier (TR-1 and TR-2), and passed into the RF filter. This filter is a high Q helicalized resonators with excellent bandpass characteristics and shock-proof construction. From the output of the helicalized resonators, the signal is fed to the gate of the first mixer (TR-3), where it is mixed with the output from the receiver crystal oscillator unit (U-1 124-101-02), which is fed into the source of TR-3 to obtain the 10.7 MHz (IF signal). All transistors in the receiver RF unit are field effect transistors, which have the highest possible sensitivity and signal to noise ratio and the lowest possible cross modulation.

- 6.2 **Receiver Crystal Oscillator Module U-1 (124-101-02)**
 This is a third overtone oscillator circuit at 45 MHz, using TR18. The trimmers in series with the crystals make it possible to alter the crystal frequency several kHz. The output is taken from the secondary of T4 and tripled by TR19. The output signal is then fed into the First Mixer in the receiver RF unit. (TR3), giving the first IF of 10.7 MHz.
- 6.3 **Receiver 1st IF Amplifier, 2nd Mixer, 2nd IF amplifier, Limiter and Discriminator Module U-2(124-201-02).**
 The 10.7 MHz signal from the RF unit is amplified by TR4. The 2nd Oscillator (TR12) is crystal controlled and operates on 10.245 MHz. The output is taken from the emitter of TR12 and fed into the base of the 2nd Mixer (TR5) to obtain the 455 Hz. IF signal, which is passed through the ceramic filter (CF), and amplified by TR6, IC1 and IC2. The output of IC2 is then detected in the discriminator circuit, consisting of T12, T13, D1 and D2.
- 6.4 **Receiver Audio Amplifier and Squelch Speech Amplifier Module U-2 (124-201-02).** The output of the discriminator drives two circuits: the audio amplifier, and the squelch. The audio signal, after being adjusted by the volume control (VR2), is then fed into the pre-amplifier circuit (TR13 and TR14), then mixed in the audio power amplifier circuit (TR15, TR16 and TR17), in order to get an audio output power of 1.5 watts.
 The squelch control is made of TR7, TR8, TR9, TR10, Diode D3 and D4. In the absence of a signal, the noise component at the output of the discriminator is amplified by TR7 and TR8. This amplified noise component is rectified by Diode D3 and D4 through the squelch control (VR1), and then coupled to the DC amplifier (TR9 and TR10). The output of TR10 is coupled to the emitter circuit of TR13 via D11. When the squelch control is adjusted, the amount of DC required to cut off TR13 is found, thus establishing the squelch threshold. When a signal is incoming through the discriminator, this bias is overcome, permitting the audio amplifier and driver to perform normally.
- 6.5 **Power Supply Circuit Module U-5 (124-500-01)**
 This circuit provides TX drive circuit (TR31) with a regulated power source, and control the TX output power when the antenna is mismatched.
 The action of transistors TR33, TR34, TR35 and TR36 is described in the APC circuit.
 Resistor VR7 connected to the resistor network, consisting of resistor R132 and R133, is used to provide an adjustment in output when the function switch is set in the low power position. Adjustment of this resistor controls the base drive of the regulator transistors TR34, TR35 and TR36. This adjustment in effect controls the actual voltage supplied to the driver transistor TR31, when the function switch is in the low power position. The output power can be set to any value from tenth of a watt to a few watts.
- 6.6 **Transmitter Crystal Oscillator and Phase Modulator Module U-1**
 Transistor TR23 operates as a fundamental oscillator at a frequency of 12 MHz. TR24 which operates as a buffer amplifier between the oscillator and phase modulator circuit. Trimmer capacitors are provided in series with each crystal which allows the frequency of the oscillator to be varied by several kHz. Thus the final output of the transmitter can be set precisely on the desired frequency.

The signal from the microphone is amplified by TR20 and TR21, then fed into the deviation limiter, which consists of D13, D14 and the active audio filter, and further amplified by TR22 before being fed into the modulation circuit in the transmitter unit.

The phase modulator circuit consists of Varactor diode D15 and L10. This audio voltage is derived from the speech amplifier.

6.7 Transmitter Multiplier and Pre-driver Module U-1

The modulated signal from diode D15 is multiplied twelve times to a final frequency of 144 MHz by transistors TR26, TR27 and TR28. These transistors act as, in order, frequency tripler, doubler, and doubler. The 144 MHz signal is amplified by TR29 and TR30 to a power of 0.3 watt. This signal is fed into the power amplifier.

6.8 Transmitter Power Amplifier U-4 (124-400-01) and Automatic Protection Circuit (APC) Module U-3 (124-400-01)

The signal from the multiplier and pre-driver unit is amplified to 15 watts by transistors TR31 and TR32, which is coupled to the antenna through the spurious filter consisting of L22, L23, and L24, and the Automatic Protection Circuit (APC).

The APC acts to decrease output of Transistors TR31 and TR32 if the antenna is seriously mismatched. A reflected power is detected by L25 and D17. When the antenna is mismatched, this circuit senses a high reflected power and provides base drive to transistor TR33 in the power supply unit. The transistor TR33 will conduct sufficient base drive to reduce the base drive of transistor TR34.

When transistor TR34 begins to turn off it reduces the complementary transistor pair, TR35 and TR36, which acts as a series regulator for the voltage supplied to the driver transistor TR31 and TR32. When they begin to turn off, due to a lack of base drive, the voltage being supplied to TR31 and TR32 is reduced to about six or eight volts, which reduces the power output to a safe value. This lower power prevents damage to TR31 and TR32 when the antenna is mismatched.

SECTION VII MAINTENANCE

7.1 Overall Alignment:

The Clegg MARK 3 has been factory aligned to produce full specified performance over the 146–148 MHz range on both transmit or receive. Only when operation is required over a different portion of the 2 meter band or after replacement of a major component should realignment of necessary.

If realignment is indicated it is recommended that the owner contact Clegg Division, Service Manager for detailed instructions.

7.2 Frequency Netting, Transmitter:

- a. Remove the eight self tapping screws on the both sides of the cabinet. Separate the Chassis from the cabinet.
- b. Connect a dummy load (50 ohms) or a wattmeter to coax connector.
- c. Connect the microphone to the microphone jack.
- d. To align the transmitter on a desired frequency, switch the channel control to the desired channel. Slowly adjust the trimmer capacitor for that channel until the desired frequency is achieved. Consult Fig. 1 for the location of the proper trimmer. These trimmers should be adjusted very slowly while the transmit frequency is observed on suitable measuring equipment. Another MARK 3 equipped with a discriminator meter can serve well for this purpose. However, it must be adapted.

This adaptation can be accomplished by installing a 50 microampere ϕ center meter. Install the meter to accessory plug (4 pin, and ground 2 pin). With the MARK 3 meter installed, in the receive mode on the channel desired, adjust the trimmer capacitor for the null point on the meter.

- e. The multipliers, driver and power output stages should be aligned on LOW power first then set the function switch on HIGH power. Align these stages according to the alignment chart provided. (See Alignment Chart).

Be careful not to transmit for more than 5 Seconds during each alignment step. As damage could be caused to the transistors due to overload during this procedure.

7.3 Frequency Netting, Receiver:

- a. Remove the microphone from the transceiver to prevent accidental transmission during receiver alignment.
- b. Allow the test oscillator or generator to stabilize output frequency drift.
- c. Connect the test oscillator or generator to the antenna coax connector. Set the test oscillator or generator to the desired frequency. Set the squelch control to the maximum counter clockwise position.
- d. Align the receiver according to the chart provided. (See Alignment Chart).
- e. When setting the receiver to a desired frequency, a discriminator meter should be connected to Accessory plug and the receiver trimmer capacitors adjusted to cause the S meter to read a maximum and the discriminator meter to read zero. Refer to Fig. 1 for the location of the proper trimmer corresponding to discriminator meter.

MARK 3 BLOCK DIAGRAM

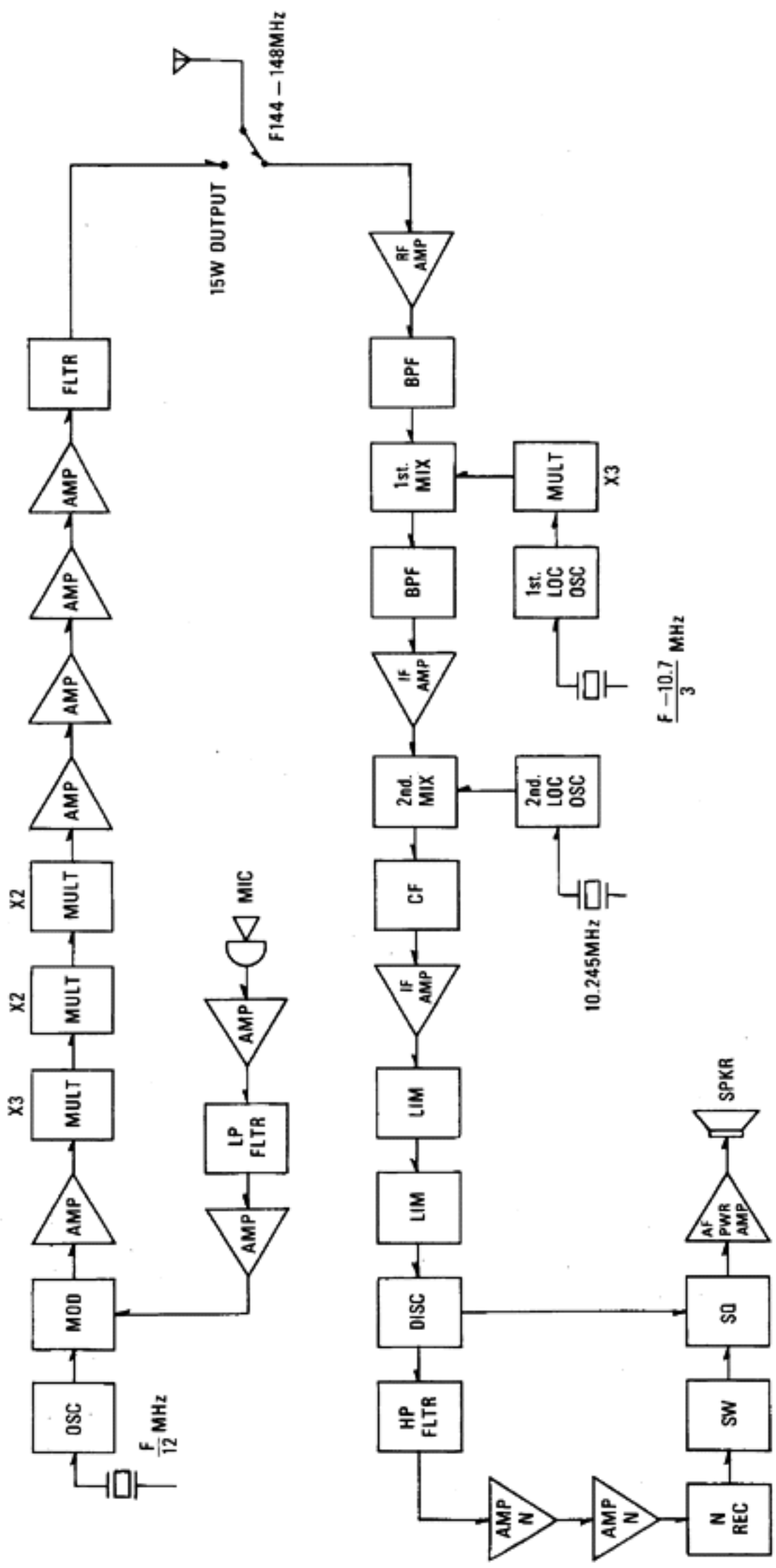

ALIGNMENT CHART

MARK 3 VOLTAGE CHART

NO.	NAME	BASE	EMITTER	COLLECT	CHECKPNT	REMARKS
TR 1	JF1033	0(G)	0.44(S)	5.5 (D)		FET
2	JF1033	0(G)	0.97(S)	6.17(D)		FET
3	JF1033	0(G)	1.2 (S)	7.17(D)		FET
4	2SC839	1.19	0.52	6.64		
5	2SC839	1.16	0.51	6.65		
6	2SC839	1.62	0.98	7.09		
IC 1	μ PC555A	1.47 (3.5)	6.79 (1,7)	7.19 (8)		(PIN Numbers)
2	μ PC555A	1.46 (3,5)	6.79 (1,7)	7.19 (8)		(PIN Numbers)
TR 7	2SC945	0.65	0	5.05		
8	2SC945	0.47	0	5.05		
9	2SC945	0	0	7.18		Unsquelled
10	2SA643	7.18	0.12	7.19		Unsquelled
11	2SC839	1.07	0.37	7.16		
12	2SC839	2.10	1.57	6.79		
13	2SC945	0.65	0.12	0.93		
14	2SC945	0.73	0.15	4.59		
15	2SC945	0.64	0	6.6		
16	2SC684	6.58	0	7.23		
17	2SC1384	7.86	7.24	13.8		
18	2SC889	1.1	1.0	6.8		
19	2SC889	0.76	0.9	7.0		1st out 120mV
20	2SC945	0.64	0.07	3.8		
21	2SC945	0.64	0.07	3.8		
22	2SC945	0.64	0.08	3.7		
23	2SC839	1.0	0.4	6.7		
24	2SC839	0.95	0.4	6.7		
25	2SC839	1.0	0.4	5.6		
26	2SC839	0.4	0.6	5.1		
27	2SC839	0.8	0.6	5.0		
28	2SC763	0.7	0.6	7.2		
29	2SC763	0.4	0.3	13.7		RF out 2.2V
30	2SC730	2.6	0	13.1		
31	2N6080	7.6	0	11.6		
32	2N6081	5.9	0	13.1		
33	2SC945	0.19	0	2.39		
34	2SC945	2.36	2.21	12.45		
35	2SA733	12.45	12.45	13.02		
36	2SC1096	12.45	11.84	13.02		

Note: 1. They were measured by DC Volt Meter 33.3K Ω /V, \pm 3%.

2. Datas. From TR23 to TR35 were measured by DC Volt-Meter (Note 1) with 10K Ω Resistor of its probe.

CIRCUIT DIAGRAM

