

REALISTIC[®]

Service Manual

21-1512

CB 40-CHANNEL TRANSCEIVER TRC-419

Catalog Number: 21-1512



CUSTOM MANUFACTURED FOR RADIO SHACK, A DIVISION OF TANDY CORPORATION

CONTENTS

SPECIFICATIONS	3
BLOCK DIAGRAM	5
ALIGNMENT INSTRUCTIONS	6
CHANNEL FREQUENCY GENERATION TABLE	12
TROUBLESHOOTING	13
PRINTED CIRCUIT BOARD (TOP/BOTTOM VIEWS)	14
WIRING DIAGRAM	17
EXPLODED VIEW/DISASSEMBLY	18
EXPLODED VIEW PARTS LIST	19
ELECTRICAL PARTS LIST	21
SEMICONDUCTOR LEAD IDENTIFICATION AND IC INTERNAL DIAGRAM	30
SEMICONDUCTOR VOLTAGE CHART	34
SCHEMATIC DIAGRAM	36

COPYRIGHT 1987. TANDY CORPORATION
ALL RIGHTS RESERVED.
REALISTIC IS A REGISTERED TRADEMARK OF TANDY CORPORATION.

SPECIFICATIONS

GENERAL

Description

Transmitter	Crystal controlled PLL synthesizer, amplitude modulation
Receiver	Crystal controlled double conversion, superheterodyne system
Communicating frequencies	40 CB channels (26.965 to 27.405 MHz)
Voltage operation	12 – 16V DC (negative only ground)
Temperature and Humidity range	-22° F to + 140° F (-30° C to +60° C) and 10% to 90%
Transmitter/Receiver switching	Electrical

STANDARD TEST CONDITIONS

Battery supply voltage	13.8V DC
Modulation	1000 Hz, 30%
Receiver output power	500mW at external SP
Receiver output impedance	8 ohms, non-inductive
Ant. load impedance of transmitter	50 ohms, non-inductive
Ambient conditions	
Temperature	63° F to 73° F (17° C to 23° C)
Humidity	40% to 70%

TRANSMITTER

Description	Nominal	Limit
RF power output	4.0 watts	3.6 – 4.4 watts
Antenna spurious emission	70	50
Modulation capability (positive/negative)	+90%/-90%	+80%/-80%
AMC Range at 1 kHz	40 dB	30dB
Frequency accuracy	0.002%	0.005%
Spurious radiation & Harmonic		
Signal radiation ratio from fundamental	-65dB	-60dB
Current consumption		
at no modulation	1000 mA	1200 mA
at 80% modulation	1500 mA	1700 mA
Envelope distortion	10% max. 1000 Hz, 50% mod.	
Stability against variation of antenna impedance	Satisfactory when dummy antenna is varied from 40 ohms to 200 ohms.	

RECEIVER

Description	Nominal	Limit
Intermediate frequency		
1st IF	10.695 MHz	
2nd IF	455 kHz	
Sensitivity for 500 mW output	0.3 μ V	1 μ V
Sensitivity at 10dB S + N/N	0.7 μ V	1.0 μ V
Adjacent channel rejection	65dB	55dB
Image rejection (1st IF/2nd IF)	70dB	60dB
IF rejection ratio (1st IF/2nd IF)	60dB	45dB
Signal-to-Noise ratio		
at 1 mV input	40dB	35dB
Distortion at 1 mV input,		
30% mod. (500 mW out)	3%	5%
AGC Figure of merit at 50 mV input	80dB	70dB
Power output at 1 mV Input		
Undistorted (10% THD)	4.5W	4.0W
Maximum	5.0W	4.5W
Electrical fidelity compared to 1000 Hz	5.0	4.5
450 Hz	-4dB	-6 \pm 3dB
2500 Hz	-6dB	-6 \pm 3dB
Cross modulation	50dB	40dB
Squelch	60dB	60 \pm 6dB
Current consumption (no signal)	250 mA	300 mA
"S" meter sensitivity to light 3th LED	40dB	40 \pm 6dB

PUBLIC ADDRESS

Description	Nominal	Limit
10% THD output power	4W	3.5W
Microphone sensitivity for 4W	5mV	10mV
Current drain at 10% THD power	1000mA	1200 mA

OTHER ITEMS

Fuse	ORG wire: 1 Amp. RED wire: 2 Amp.
General power requirement	12 - 16V DC
Dimensions	(H) 1-9/16" (40mm) x (W) 4-15/16" (125mm) x (D) 8-5/32" (207mm)
Weight	2 lbs 10 oz (1.2kg)

NOTE: Nominal specs represent the design specs; all units should be able to approximate these - some will exceed and some may drop slightly below these specs. Limit specs represent the absolute worst condition which still might be considered acceptable; in no case should a unit perform to less than within any limit spec.

BLOCK DIAGRAM

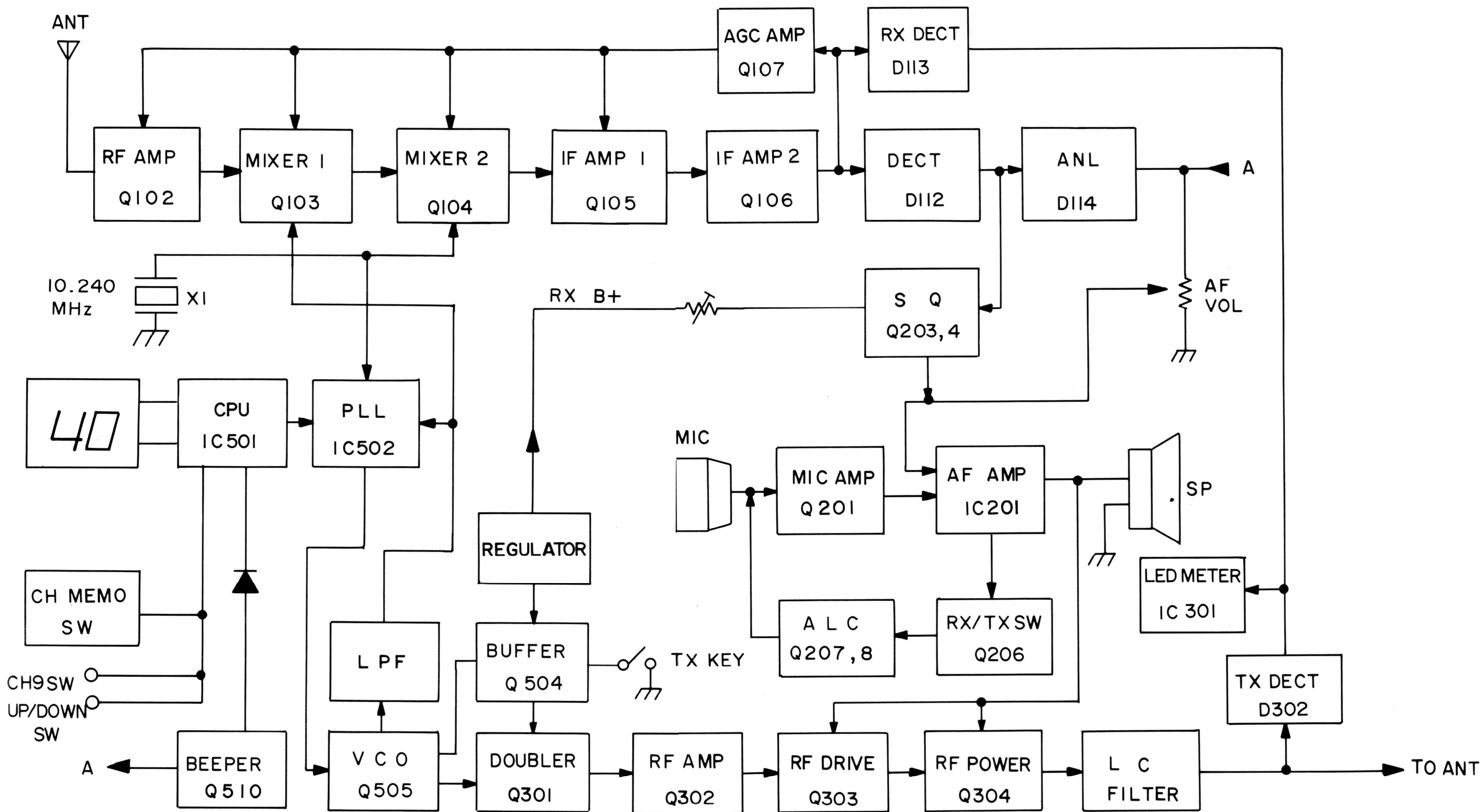

ALIGNMENT INSTRUCTIONS

A. PHASE LOCKED LOOP AND CPU SECTION

1. Test Equipment Required

- a. Frequency Counter
- b. DC Power Supply (13.8Volt, 3 Amp.)
- c. DC Voltmeter
- d. Oscilloscope

NOTE: Figure 1 provides test point and alignment location information.

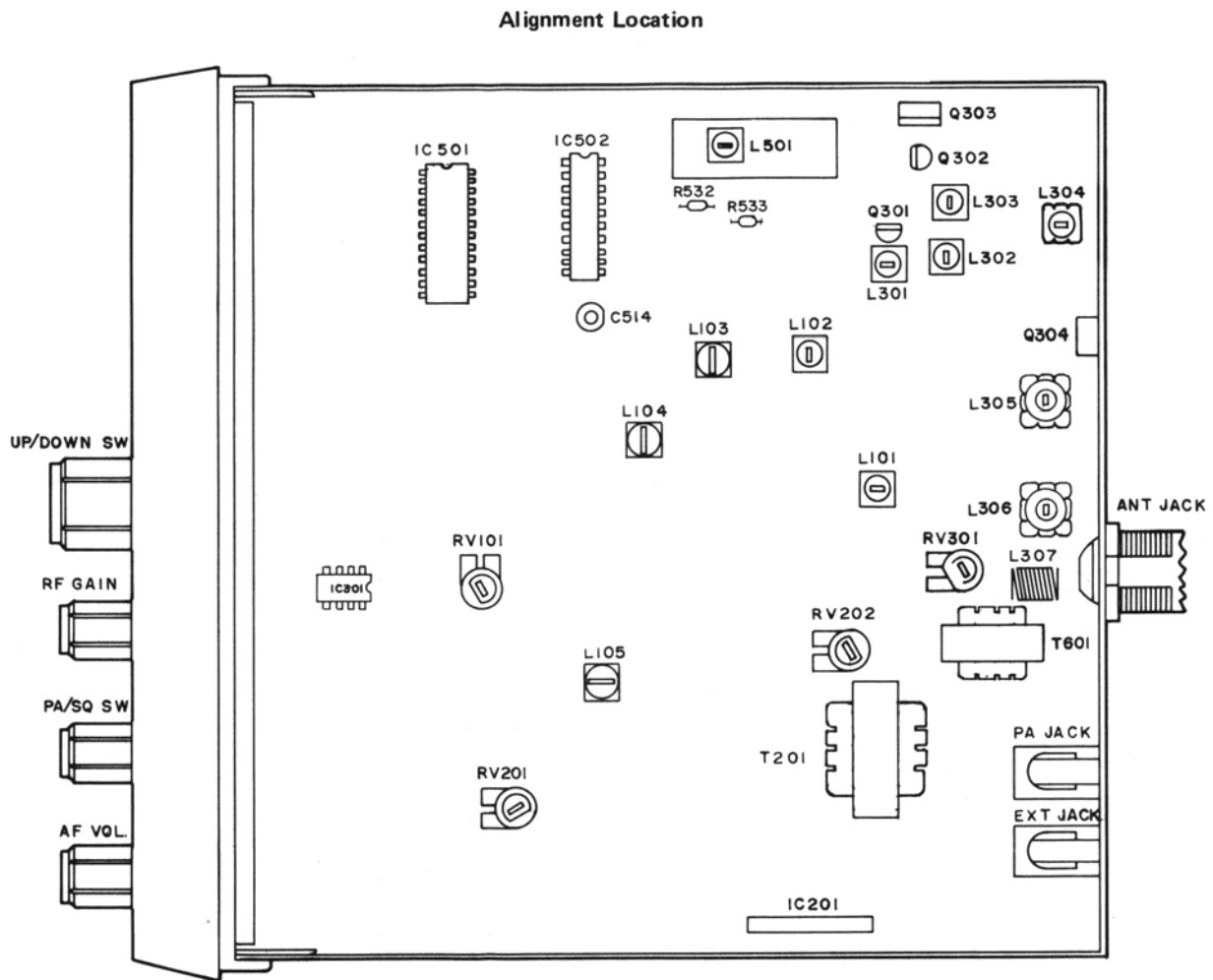

Figure 1

2. Alignment Procedure

STEP	SETTING	CONNECTION	ADJUST	ADJUST FOR
1.	Frequency adjustment MIC: Receive Volume: Optional Squelch: Optional CH Selector: Optional RF Gain: Optional	Frequency counter to output pin 12 of IC502 (Figure 2).	C514	10.240MHz \pm 100Hz
2	RX VCO voltage adjustment MIC: Receive Volume: Optional Squelch: Turn Clockwise CH Selector: 1 RF Gain: Optional	Connect DC voltmeter between R532 and R533 (Figure 3).	L501	1.5V
3	TX VCO voltage adjustment MIC: Transmit Volume: Optional Squelch: Optional CH Selector: 1 RF Gain: Optional	Connect DC voltmeter between R523 and R533 (Figure 3).	L501	Indication on DC voltmeter must be 1.0-2.0 Volt. If DC voltmeter does not indicate 1.0-2.0 volt, readjust L501.
4	CPU IC Voltage check MIC: Receive Volume: Optional Squelch: Optional CH Selector: Optional RF Gain: Optional	Connect DC voltmeter to pin 2 of IC501.		Indication on DC voltmeter must be 4-5 volt.
5	CPU frequency check MIC: Receive Volume: Optional Squelch: Optional CH Selector: Optional RF Gain: Optional	Connect oscilloscope to pin 16 of IC501 (Figure 4).		Check for 300-400kHz of triangle waveform as Figure 4.

FREQUENCY COUNTER

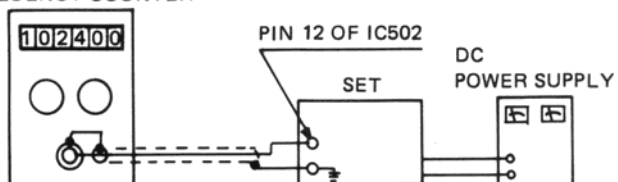

Figure 2

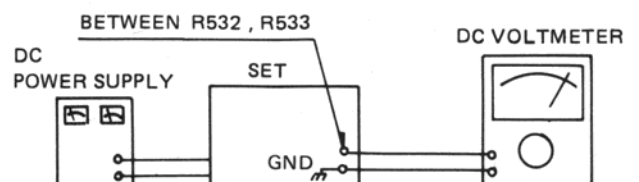

Figure 3

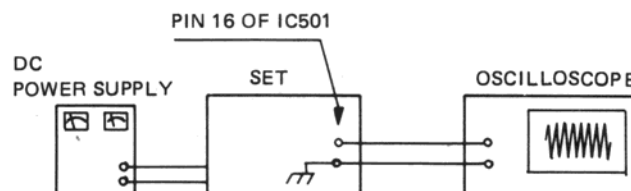

Figure 4

B. TRANSMITTER SECTION

1. Test Equipment Required

- | | |
|--------------------------------|--|
| a. RF Powermeter | f. DC Power supply (13.8 Volt, 3 Amp.) |
| b. 50 ohm load (non-inductive) | g. Spectrum Analyzer |
| c. RF Attenuator | h. Frequency Counter |
| d. Oscilloscope | i. Coupler |
| e. Audio Generator | |

2. Alignment procedure

STEP	SETTING	CONNECTION	ADJUST	ADJUST FOR
1	RF Driver stage MIC: Transmit Volume: Optional Squelch: Optional CH Selector: 19 RF Gain: Optional	Connect SSVM to base of Q302 (Figure 5).	L301 L302	Adjust for maximum indication on RF SSVM.
2	RF Power stage MIC: Transmit Squelch: Optional Volume: Optional CH Selector: 19 RF Gain: Optional	Connect dummy load and RF power meter to the EXT-ANT. Jack on the set (Figure 6).	L303 L304 L305 L306	Adjust for maximum indication on RF power meter (4 watts). If indication is not in 4 watts range, go back to step 1 and readjust L303, L304, L305, L306.
3	Modulation adjustment MIC: Transmit Volume: Optional Squelch: Optional CH Selector: 19 RF Gain: Optional	Connect audio generator (1kHz) to pin 4 of microphone connector (Figure 7). Adjust audio signal level to obtain 80%-90% modulation level. Connect dummy load and oscilloscope through coupler to RF power meter. Connect RF power meter to EXT-ANT. jack on the set.	RV202	Check for proper modulation pattern on the oscilloscope.
4	Second harmonic check MIC: Transmit Volume: Optional Squelch: Optional CH Selector: 19 RF Gain: Optional	Connect RF power meter with dummy load and spectrum analyzer through coupler/-40dB attenuator to EXT-ANT. Jack on the set (Figure 9).		At no modulation, compare the level of fundamental frequency to the level of harmonic frequency. Suppression of the 2nd harmonic frequency level must be lower than -60dB. Check for the other channels.
5	Frequency check MIC: Transmit Volume: Optional Squelch: Optional Channel selector: 19 RF Gain: Optional	Connect dummy load and frequency counter through coupler to RF power meter. Connect RF power meter to EXT-ANT. jack on the set. (Figure 8).	C514	Make sure that the indication of the transmitter frequency is 27.185MHz \pm 300Hz on the frequency counter.

STEP	SETTING	CONNECTION	ADJUST	ADJUST FOR
6	TX Power LED adjustment MIC: Transmit Volume: Optional Squelch: Optional Channel Selector: RF Gain: Optional	Connect dummy load and frequency counter through coupler to RF power meter. Connect RF power meter to EXT-ANT. jack on the set (Figure 6).	RV301	Adjust so that 3rd LED light up at 4 watts RF output power.

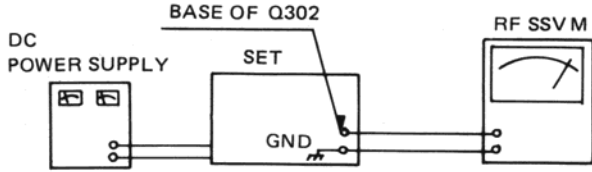

Figure 5

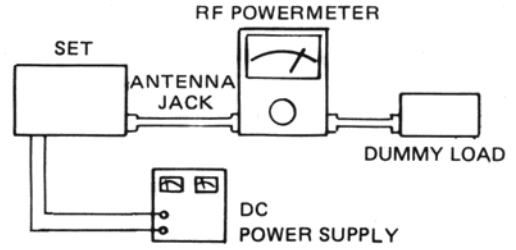

Figure 6

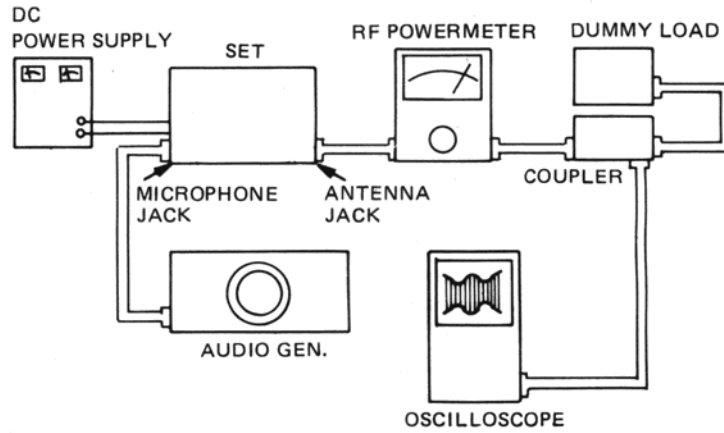

Figure 7

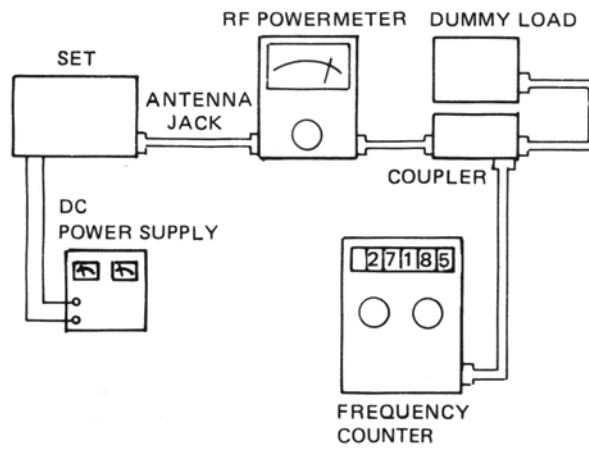

Figure 8

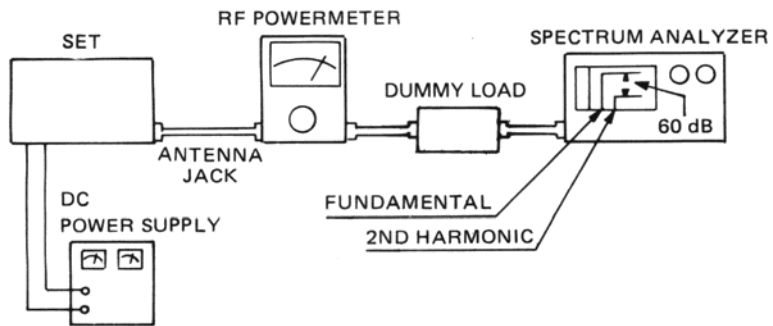

Figure 9

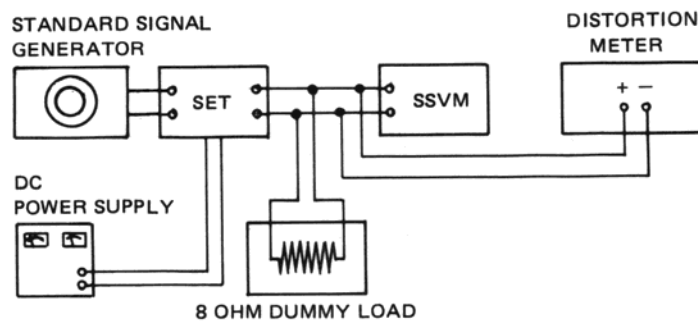

Figure 10

C. RECEIVER SECTION

1. Test Equipment Required

- a. RF signal Generator
- b. SSVM
- c. Distortion Meter
- d. Power Supply

2. Alignment procedure

STEP	SETTING	CONNECTION	ADJUST	ADJUST FOR
1	MIC: Receive Volume: Fully clockwise Squelch: Turn to counterclockwise CH Selector: 19 RF Gain: Fully clockwise SSG: 27.185MHz, 1kHz 1 μ V 30% Mod.	Connect RF signal generator to EXT-ANT. Jack. Connect SSVM and distortion meter across EXT. speaker jack with 8 ohm dummy load (Figure 10).	L101 L102 L103 L104 L105	Adjust for maximum indication on SSVM. Reduce output from RF SG until the audio output becomes about 500mW (2V).
2	MIC: Receive SSG: 27.185MHz 1kHz 1mV 80% Mod. Squelch: Turn to counterclockwise RF Gain: Fully clockwise CH Selector: 19 Volume: 500mW (2V)	Connect RF Signal generator to EXT-ANT. Jack. Connect SSVM and distortion meter across EXT. speaker jack with 8 ohm dummy load (Figure 10).	L104	Adjust for minimum indication on distortion meter.
3	Squelch adjustment MIC: Receive SSG: 27.185MHz, 1kHz 1mV 30% Mod. Squelch: Clockwise CH Selector: 19 Volume: 500mW (2V) RF Gain: Fully clockwise	Connect RF signal generator to EXT-ANT. Jack. Connect SSVM and distortion meter across EXT. speaker jack with 8 ohm dummy load (Figure 10).	RV201	Adjust RV201 until the Audio output just appeared.
4	RF Signal meter adjustment MIC: Receive SSG: 27.185MHz, 1kHz 100 μ V 30% Mod. Squelch: Fully counterclockwise Volume: 500mW (2V) RF Gain: Fully clockwise	Connect RF signal generator to EXT-ANT. Jack. Connect SSVM and distortion meter across the EXT. speaker jack with 8 ohm dummy load. (Figure 10).	RV101	Adjust so that the 3rd LED on the S/RF meter light up.

CHANNEL FREQUENCY GENERATION TABLE

RECEIVE

VCO FREQUENCY = N x 5 (kHz)

TRANSMIT

VCO FREQUENCY = N x 2.5 (kHz)

TRANSMIT FREQUENCY = VCO FREQUENCY x 2

CHANNEL	BCD INPUT TO IC-1								RECEIVE		TRANSMIT		
	D1 (1F)	D2 (1A)	D3 (1G)	D4 (1E)	D5 (1B)	D6 (2C)	D7 (2N)	D8 (2F)	N	VCO FREQUENCY (MHz)	N	VCO FREQUENCY (MHz)	TRANSMIT FREQUENCY (MHz)
1	1	1	1	1	0	1	1	1	3254	16.27	5393	13.4825	26.965
2	1	0	0	0	0	1	1	1	3256	16.28	5395	13.4875	26.975
3	1	0	0	1	0	1	1	1	3258	16.29	5397	13.4925	26.985
4	0	1	0	1	0	1	1	1	3262	16.31	5401	13.5025	27.005
5	0	0	0	1	1	1	1	1	3264	16.32	5403	13.5075	27.015
6	0	0	0	0	1	1	1	1	3266	16.33	5405	13.5125	27.025
7	—	0	1	1	0	1	1	1	3268	16.34	5407	13.5175	27.035
8	0	0	0	0	0	1	1	1	3272	16.36	5411	13.5275	27.055
9	0	0	0	1	0	1	1	1	3274	16.37	5413	13.5325	27.065
10	0	0	1	0	0	0	1	1	3276	16.38	5415	13.5375	27.075
11	1	1	1	1	0	0	1	1	3278	16.39	5417	13.5425	27.085
12	1	0	0	0	0	0	1	1	3282	16.41	5421	13.5525	27.015
13	1	0	0	1	0	0	1	1	3284	16.42	5423	13.5575	27.115
14	0	1	0	1	0	0	1	1	3286	16.43	5425	13.5625	27.125
15	0	0	0	1	1	0	1	1	3288	16.44	5427	13.5675	27.135
16	0	0	0	0	1	0	1	1	3292	16.46	5431	13.5775	27.155
17	—	0	1	1	0	0	1	1	3294	16.47	5433	13.5825	27.165
18	0	0	0	0	0	0	1	1	3296	16.48	5435	13.5875	27.175
19	0	0	0	1	0	0	1	1	3298	16.49	5437	13.5925	27.185
20	0	0	1	0	0	1	0	1	3302	16.51	5441	13.6025	27.205
21	1	1	1	1	0	1	0	1	3304	16.52	5443	13.6075	27.215
22	1	0	0	0	0	1	0	1	3306	16.53	5445	13.6125	27.225
23	1	0	0	1	0	1	0	1	3312	16.56	5451	13.6275	27.255
24	0	1	0	1	0	1	0	1	3308	16.54	5447	13.6175	27.235
25	0	0	0	1	1	1	0	1	3310	16.55	5449	13.5225	27.245
26	0	0	0	0	1	1	0	1	3314	16.57	5453	13.6325	27.265
27	—	0	1	1	0	1	0	1	3316	16.58	5455	13.6375	27.275
28	0	0	0	0	0	1	0	1	3318	16.59	5457	13.6425	27.285
29	0	0	0	1	0	1	0	1	3320	16.60	5459	13.6475	27.295
30	0	0	1	0	0	0	0	1	3322	16.61	5461	13.6525	27.305
31	1	1	1	1	0	0	0	1	3324	16.62	5463	13.6575	27.315
32	1	0	0	0	0	0	0	1	3326	16.63	5465	13.6625	27.325
33	1	0	0	1	0	0	0	1	3328	16.64	5467	13.6675	27.335
34	0	1	0	1	0	0	0	1	3330	16.65	5469	13.6725	27.345
35	0	0	0	1	1	0	0	1	3332	16.66	5471	13.6775	27.355
36	0	0	0	0	1	0	0	1	3334	16.67	5473	13.6825	27.365
37	—	0	1	1	0	0	0	1	3336	16.68	5475	13.6875	27.375
38	0	0	0	0	0	0	0	1	3338	16.69	5477	13.6925	27.385
39	0	0	0	1	0	0	0	1	3340	16.70	5479	13.6975	27.395
40	0	0	1	0	0	0	1	0	3342	16.71	5481	13.7025	27.405

TROUBLESHOOTING

SYMPTOM	PROBABLE CAUSE	REMEDY
Unit does not work at all	<ol style="list-style-type: none"> 1. Defective power switch VR102 2. Blown fuse 3. Broken DC power cord 4. Defective IC501 or IC502 	<ol style="list-style-type: none"> 1. Replace 2. Replace 3. Replace 4. Replace
No output from speaker at all	<ol style="list-style-type: none"> 1. Defective external speaker Jack 2. Poor connection on microphone connector 3. Defective push switch on microphone 4. Defective internal speaker 5. Defective D112, VR101, VR102, RV201 IC201 or other components 	<ol style="list-style-type: none"> 1. Repair or Replace 2. Repair or Replace 3. Repair or Replace 4. Replace 5. Replace the defective components
No noise on speaker	<ol style="list-style-type: none"> 1. Measure all the voltage of Q101 Q102, Q103, Q104, 105, 106, 107 and IC201 with voltage chart on the page 20 2. Defective squelch circuit components (RV201, VR201, IC201, Q203 Q204, Q205, Q507, Q508) 	<ol style="list-style-type: none"> 1. Replace 2. Replace 3. Replace
Squelch does not work	<ol style="list-style-type: none"> 1. Defective VR201, RV201, Q203, Q204, Q205, Q507, Q508 2. Improperly adjusted RV201 	<ol style="list-style-type: none"> 1. Replace defective components 2. Readjust
No modulation	<ol style="list-style-type: none"> 1. Defective microphone 2. Poor Audio output and defective modulation microphone amplifier components (Q201, Q202, IC201) 3. Defective microphone connector component 4. Defective ALC Circuit (Q206, Q207, Q208, D204, D205) 	<ol style="list-style-type: none"> 1. Replace 2. Replace the defective component(s) 3. Replace 4. Replace the defective component(s)
LED meter does not work	<ol style="list-style-type: none"> 1. Defective D303, D304, D305, D306 2. Defective IC301 3. Defective D302, RV301 	<ol style="list-style-type: none"> 1. Replace 2. Replace 3. Replace
LED Display does not work	<ol style="list-style-type: none"> 1. Defective orange wire fuse 2. Defective LED501, IC501 	<ol style="list-style-type: none"> 1. Replace 2. Replace
P.A does not work	<ol style="list-style-type: none"> 1. Defective VR201 2. Defective Q501, D505 	<ol style="list-style-type: none"> 1. Replace 2. Replace
Channel selector does not work	<ol style="list-style-type: none"> 1. Defective IC501, SW509 	<ol style="list-style-type: none"> 1. Replace
Memory function does not work	<ol style="list-style-type: none"> 1. Defective SW501, SW502, SQ503, SQ504, SW505, SW506, SW507 2. Defective D501, D502, D503, D504 	<ol style="list-style-type: none"> 1. Replace the defective component(s) 2. Replace the defective component(s)

PRINTED CIRCUIT BOARD(TOP/BOTTOM VIEWS)

MAIN PCB(TOP VIEW)

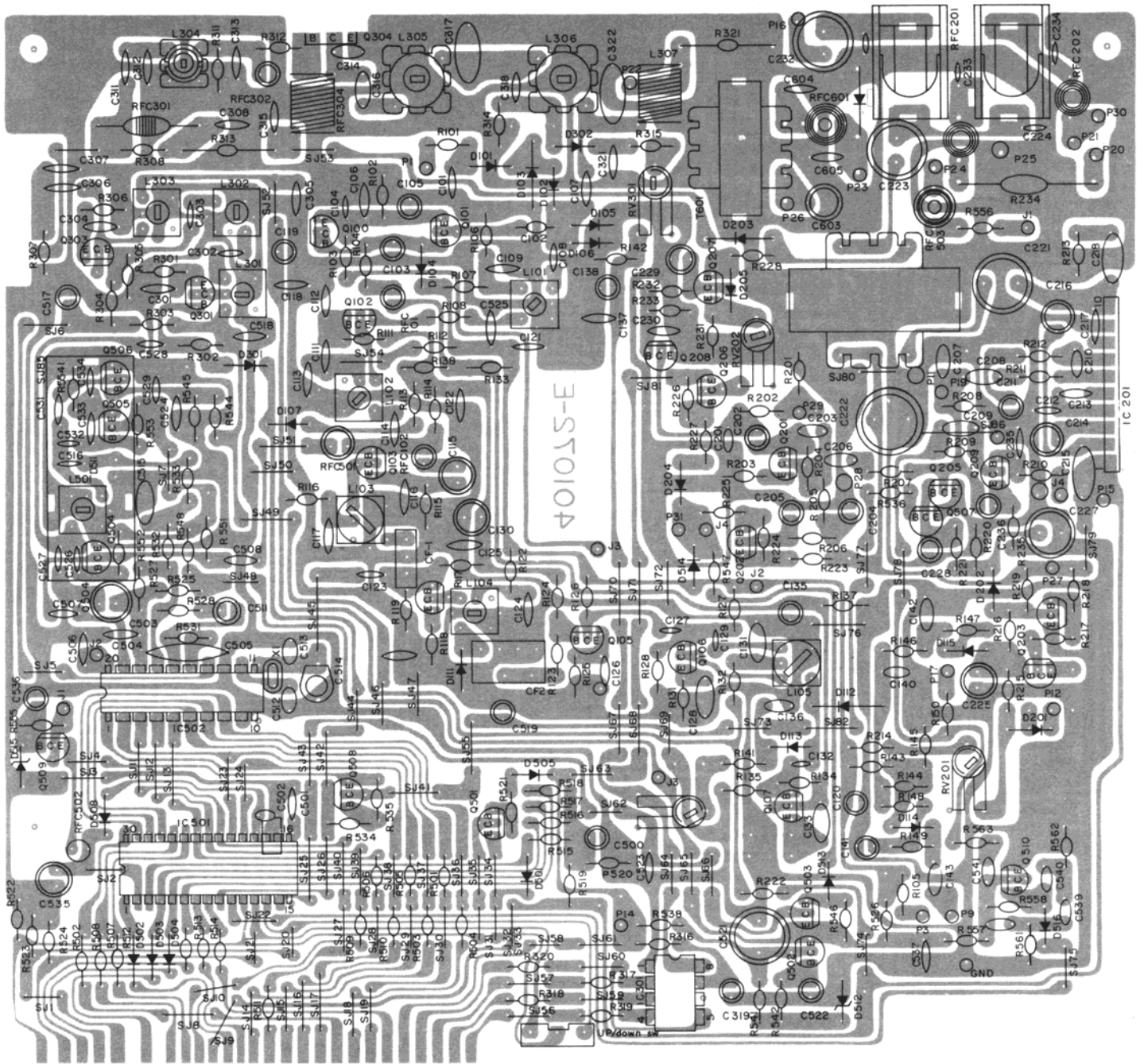

MAIN PCB (BOTTOM VIEW)

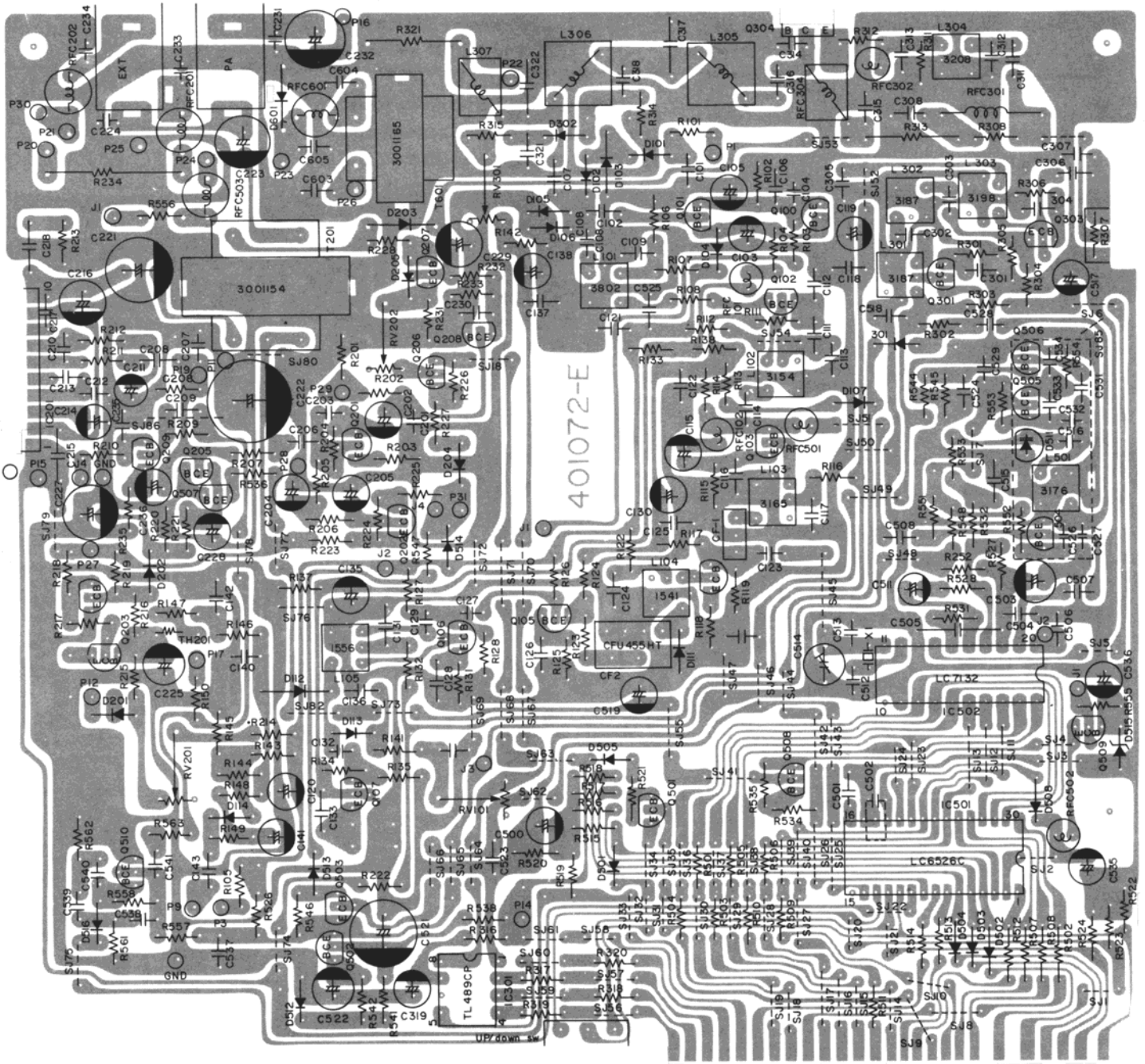

LED DISPLAY & SW PCB TOP VIEW

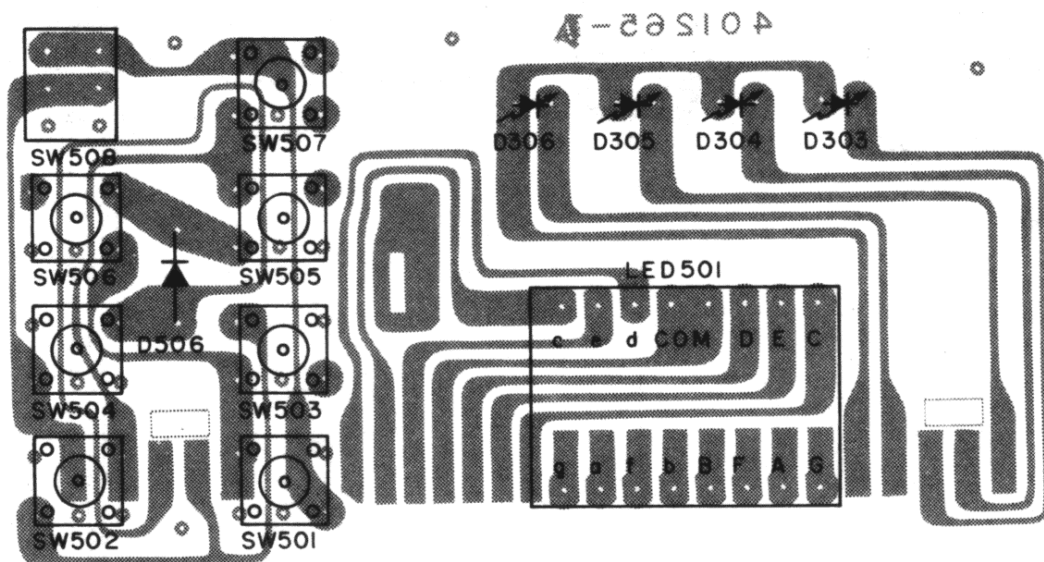

BOTTOM VIEW

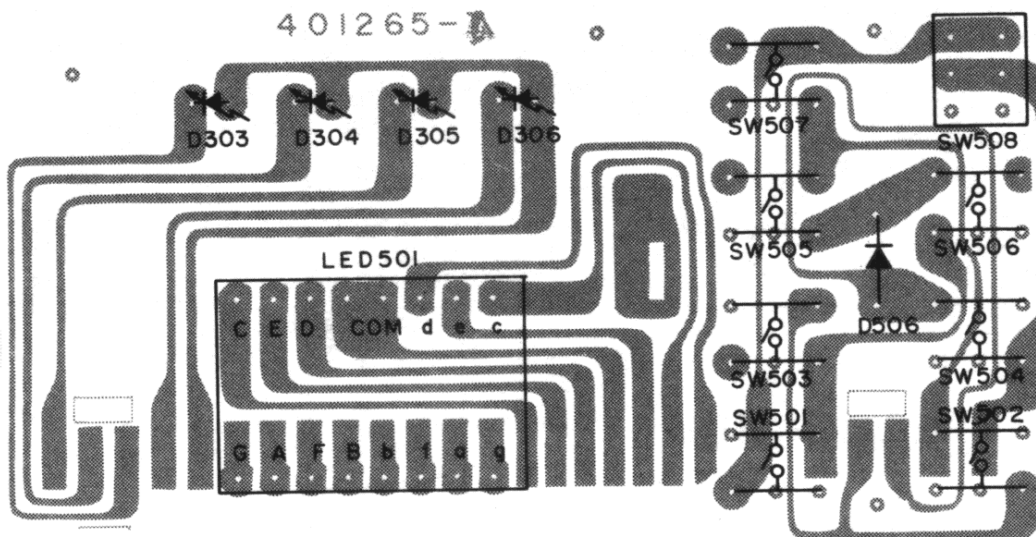

WIRING DIAGRAM

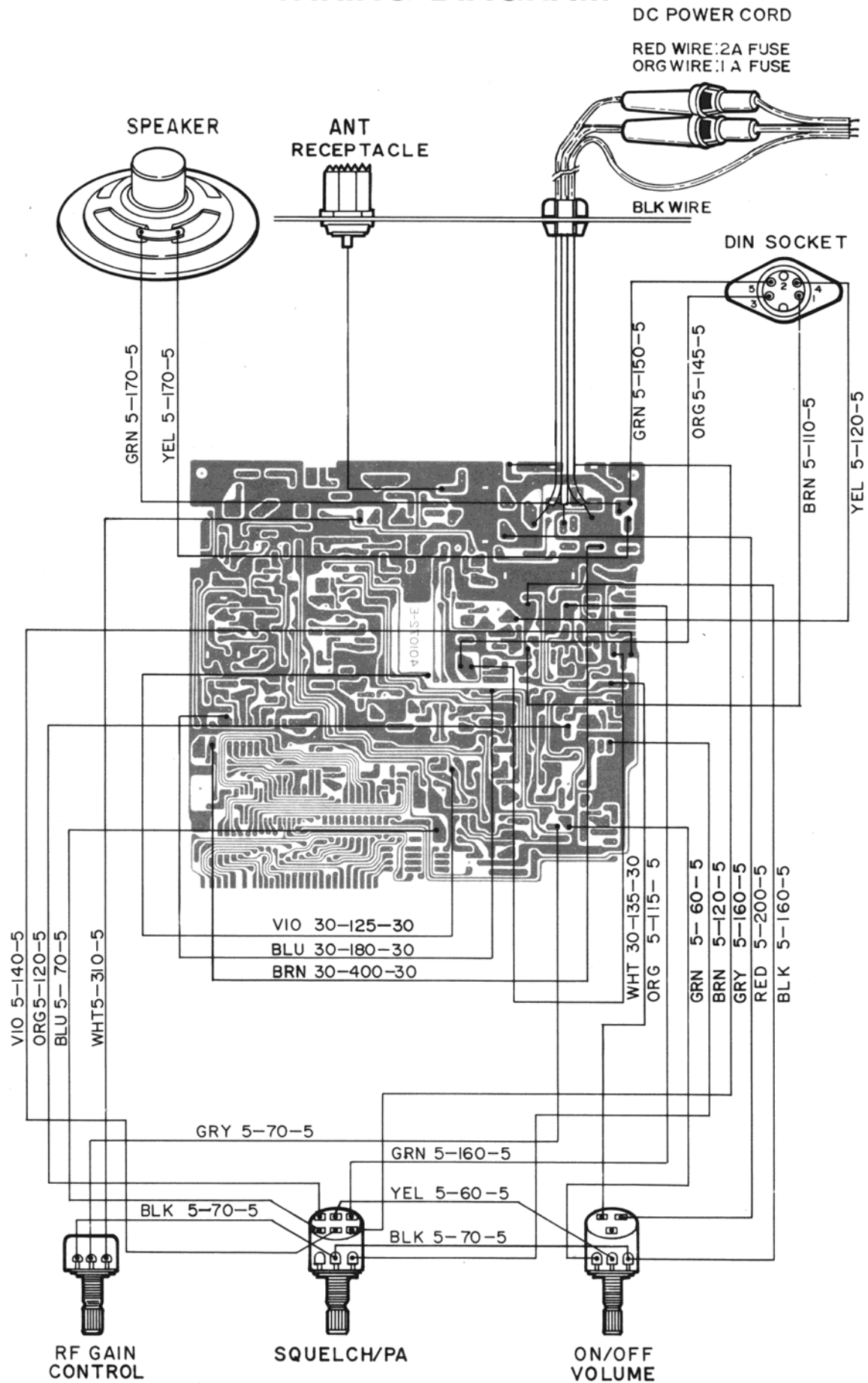

EXPLODED VIEW/DISASSEMBLY

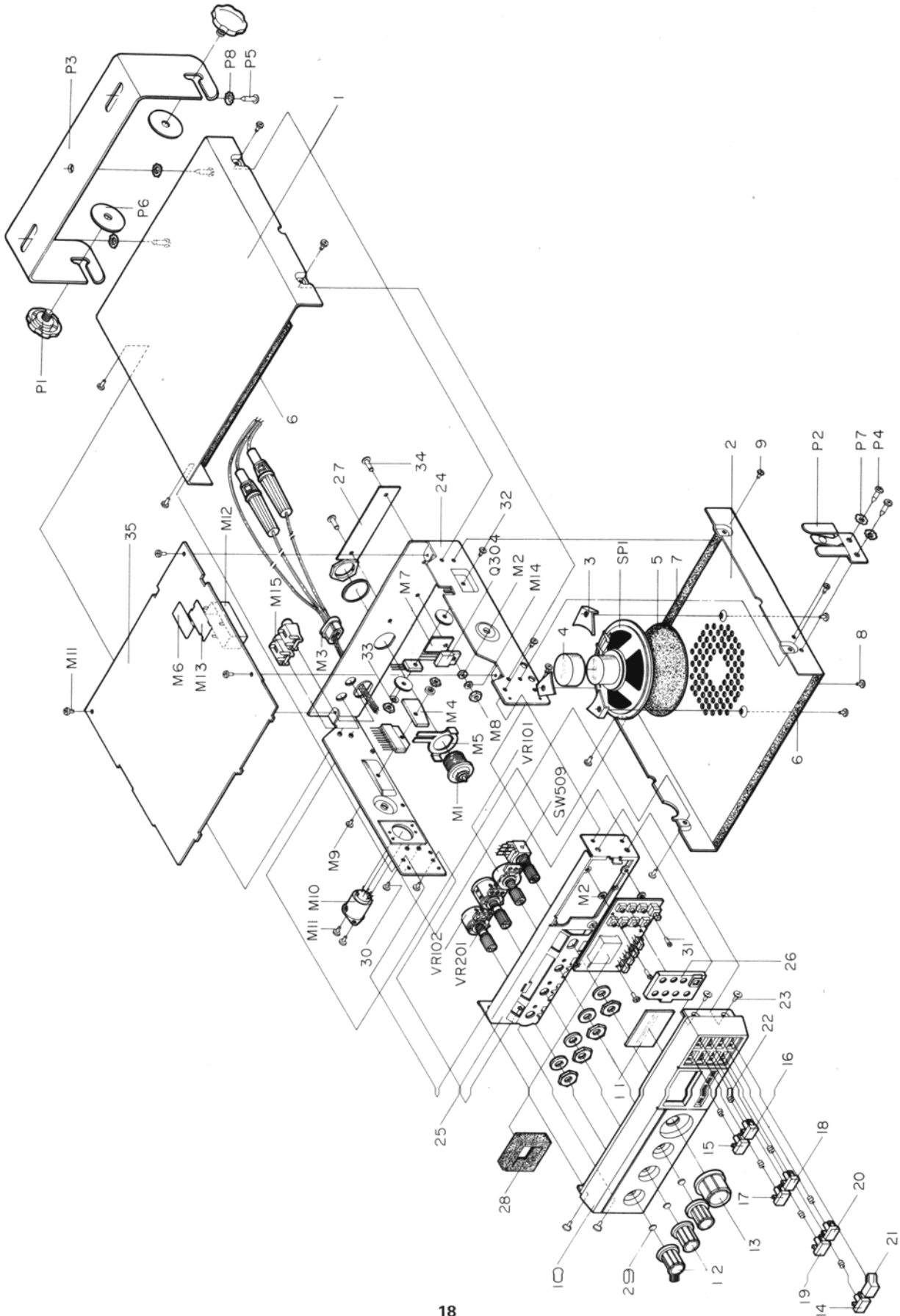

EXPLODED VIEW PARTS LIST

Ref. No.	Description	RS Location	Mfr's Part No.
1	Upper Cover	Z-1243	715-700
2	Bottom Cover	Z-1354	715-710
3	Holder - Speaker Mounting		730-015
4	Cap-Speaker		830-043
5	Felt-Speaker		900-203
6	Felt Strip-Escutcheon		901-226
7	Felt Strip		904-000
8	(+) Tapping Screw, B.H 3×8 BLK		623-104
9	(+) Tapping Screw, B.H 3×6 BLK		633-082
10	Escutcheon, BLK		800-990
11	Lens		813-250
12	Knob (Control)		820-102
13	Knob (Channel)		820-111
14	Knob (MEM)		823-970
15	Knob (M1)		823-971
16	Knob (M2)		823-972
17	Knob (M3)		823-973
18	Knob (M4)		823-974
19	Knob (M5)		823-975
20	Knob (M6)		823-976
21	Knob (CH-9)		823-980
22	Spring		880-730
23	(+) Machine Screw, F.H M3×6		613-183
24	Main Body		701-470
25	Front Body		701-550
26	Shield Plate		770-390
27	Name Plate		793-910
28	Sponge		893-110
29	Insulation Ring		900-504
30	(+) Machine Screw (P.H) M3×4		613-004
31	(+) Machine Screw (P.H) M3×5		613-022
32	(+) Machine Screw (B.H) M3×10		613-332
33	Washer Flat		660-572
34	Rivet Blind		670-025
35	Main P.C.B.		401-072-H
M1	ANT Receptacle	J-0843	992-440
M2	Bushing	HC-3805	441-004-5
M3	Cord Stopper		750-765
M4	Heat Sink		760-704
M5	Holder (ANT Mounting)		731-790
M6	Insulation Plate		902-050
M7	Mica	HC-3816	440-004-0
M8	Nut		651-024
M9	(+) Machine Screw (BH) M3×8		613-305
M10	5 pin Socket	J-7648	992-486
M11	Tapping Screw (BH) 3×5-2S		623-238
M12	Shield Plate 90×25×0.3		770-336
M13	Shield Plate 26×17×0.3	HC-3806	770-390
M14	Washer		662-305
M15	Jack, Earphone	J-1545	420-707-6

Ref. No.	Description	RS Location	Mfr's Part No.
P1	Securing Screw		600-060
P2	Bracket (MIC)		720-094
P3	Bracket (SET)		722-750
P4	(+) Tapping Screw (B.H) 3.5 × 10		624-066
P5	(+) Tapping Screw (T.H) 5 × 12		625-007
P6	Washer-Rubber		660-138
P7	Washer-Lock M3.5		664-411
P8	Washer-Lock M5		664-518
Q304	KTC2075	2SC-2075	202-057-5
SP-1	Speaker 3" 8 ohm 2W	SP-5396	420-102-9
VR101	Without/SW, B50K ohm ± 20%	P-8073	450-601-2
VR102	With/OFF-ON SW, A50K ohm ± 20%	P-8074	450-602-3
VR201	With/DPDT SW, B10K ohm ± 20%	P-8075	450-403-0

ELECTRICAL PARTS LIST

Ref. No.	Description	RS Location	Mfr's Part No.
MAIN P.C.B ASS'Y		XB-1695	501-43M-P
CAPACITORS			
C101	Ceramic 0.01 μ F 50WV +80%/-20%		130-102-9
C102	Ceramic 0.022 μ F 50WV +80%/-20%		130-207-1
C103	Elect 10 μ F 16WV \pm 20%		101-012-7
C104	Ceramic 0.0047 μ F 50WV +80%/-20%		130-402-0
C105	Elect 22 μ F 16WV \pm 20%		102-210-4
C106	Ceramic 0.01 μ F 50WV SL +80%/-20%		130-102-9
C107	Ceramic 22pF 50WV \pm 10%		132-201-5
C108	Ceramic 0.001 μ F 50WV +90%/-20%		130-101-8
C109	Ceramic 0.01 μ F 50WV +80%/-20%		130-102-9
C110	Not Used		
C111	Ceramic 0.022 μ F 50WV +80%/-20%		130-207-1
C112-C113	Ceramic 0.01 μ F 50WV +80%/-20%		130-102-9
C114	Ceramic 0.047 μ F 50WV \pm 20%		130-405-3
C115	Elect 0.47 μ F 50WV \pm 20%		100-405-4
C116-C117	Ceramic 0.01 μ F 50WV +80%/-20%		130-102-9
C118	Ceramic 0.047 μ F 50WV \pm 20%		130-405-3
C119-C120	Elect 10 μ F 16WV \pm 20%		101-012-7
C121	Ceramic 0.047 μ F 50WV \pm 20%		130-405-3
C122	Ceramic 0.022 μ F 50WV +80%/-20%		130-207-1
C123	Ceramic 10pF (NPO) 50WV \pm 10%	CF-1902	131-011-5
C124	Ceramic 0.022 μ F 50WV +80%/-20%		130-207-1
C125	Ceramic 0.01 μ F 50WV +80%/-20%		130-102-9
C126	M.P 0.022 μ F 50WV \pm 5%		192-203-5
C127	Ceramic 0.001 μ F 50WV +80%/-20%		130-101-8
C128	M.P 0.047 μ F 50WV \pm 5%		194-702-9
C129	Ceramic 2pF 50WV \pm 10%		132-003-3
C130	Elect 0.47 μ F 50WV \pm 10%		100-405-4
C131	M.P 0.047 μ F 50WV \pm 5%		194-702-9
C132	Ceramic 5pF 50WV \pm 10%		135-005-0
C133	M.P 0.047 μ F 50WV \pm 5%		194-702-9
C134	Not used		
C135	Elect 10 μ F 16WV \pm 20%		101-012-7
C136	M.P 0.01 μ F 50WV \pm 10%		191-004-7
C137	Ceramic 0.01 μ F 50WV +80%/-20%		130-102-9
C138	Elect 4.7 μ F 50WV +80%/-20%		104-707-7
C139	Not used		
C140	M.P 0.001 μ F 50WV \pm 5%		191-002-5
C141	Elect 1 μ F 50WV \pm 20%		101-006-2
C142	M.P 0.047 μ F 50WV \pm 5%		194-702-9
C143	M.P 0.0082 μ F 50WV \pm 10%		198-201-3
C200	M.P 0.022 μ F 50WV \pm 10%		192-203-5
C201	M.P 0.0047 μ F 50WV \pm 5%		194-701-8
C202	Elect 1 μ V 50WV \pm 20%		101-006-2
C203	M.P 0.01 μ F 50WV \pm 5%		191-004-9
C204	Elect 47 μ F 16WV \pm 20%		104-712-1
C205	Elect 10 μ F 16WV \pm 20%		101-012-7

Ref. No.	Description	RS Location	Mfr's Part No.
C206	M.P 0.022 μ F 50WV \pm 5%		192-203-5
C207	M.P 0.015 μ F 50WV \pm 5%		191-504-2
C208-C209	M.P 0.022 μ F 50WV \pm 5%		192-203-5
C210	M.P 0.022 μ F 50WV \pm 5%		192-201-3
C211	Tantal 3.3 μ F 16WV \pm 20%		143-301-0
C212	Ceramic 68pF 50WV \pm 10%		136-801-7
C213	Ceramic 150pF 50WV \pm 10%		131-503-3
C214	Elect 47 μ F 10WV \pm 20%		104-711-0
C215	M.P 0.068 μ F 50WV \pm 10%		196-803-7
C216	Elect 47 μ F 16WV \pm 20%		104-712-1
C217	Ceramic 220pF 50WV \pm 10%		132-204-8
C218	M.P 0.068 μ F 50WV \pm 10%		196-803-7
C219-C220	Not used		
C221	Elect 220 μ F 16WV \pm 10%		102-242-3
C222	Elect 1000 μ F 16WV \pm 20%		101-048-0
C223	Elect 100 μ F 16WV \pm 10%		101-022-6
C224	Ceramic 0.001 μ F 50WV +80%/-20%		130-101-8
C225	Elect 33 μ F 16WV \pm 20%		103-313-9
C226	Not used		
C227	Elect 100 μ F 16WV \pm 20%		101-022-6
C228	Elect 10 μ F 16WV \pm 20%		101-012-7
C229	Elect 47 μ F 16WV \pm 20%		104-712-1
C230	Ceramic 0.047 μ F 50WV \pm 20%		130-405-3
C231	Ceramic 0.001 μ F 50WV +80%/-20%		130-101-3
C232	Elect 100 μ F 16WV \pm 20%		101-022-6
C233-C234	Ceramic 0.001 μ F 50WV +80%/-20%		130-101-8
C235	Ceramic 0.01 μ F 50WV +80%/-20%		130-102-9
C236	Elect 1 μ F 50WV \pm 20%		101-006-2
C237	Elect 1 μ F 16WV \pm 20%		101-006-2
C301	Ceramic 0.01 μ F 50WV +80%/-20%		130-102-9
C302	Ceramic 4pF (NPO) 50WV \pm 10%	CF-1950	134-006-6
C303	Ceramic 100pF (NPO) 50WV \pm 10%	CF-1424	131-015-9
C304	Ceramic 0.01 μ F 50WV +80%/-20%		130-102-9
C305	Ceramic 0.047 μ F 50WV +80%/-20%		130-405-3
C306	Ceramic 100pF (NPO) 50WV \pm 10%	CF-1424	131-015-9
C307	Ceramic 330pF 50WV \pm 10%		133-302-8
C308	Ceramic 0.01 μ F 50WV +80%/-20%		130-102-9
C309-C310	Not used		
C311	Ceramic 60pF (NPO) 50WV \pm 10%	CF-7442	136-002-2
C312	Ceramic 220pF (NPO) 50WV \pm 10%	CF-1485	132-214-9
C313	Ceramic 60pF (NPO) 50WV \pm 10%	CF-7442	136-002-2
C314	Mica 100pF 50WV \pm 5%		161-005-9
C315	Ceramic 0.01 μ F 50WV +80%/-20%		130-102-9
C316	Mica 100pF 50WV \pm 10%		161-005-9
C317	Mica 270pF 50WV \pm 10%		162-702-0
C318	Ceramic 1.5pF 50WV \pm 10%		131-506-6
C319	Elect 10 μ F 16WV \pm 20%		101-012-7
C320	Not used		
C321	Ceramic 0.01 μ F 50WV +80%/-20%		130-102-9
C322	Mica 270pF 50WV \pm 10%		162-702-0
C323	Capacitor Mica 150pF 50WV \pm 10%		161-502-1
C500	Elect 10 μ F 16WV \pm 20%		101-012-7

Ref. No.	Description	RS Location	Mfr's Part No.
C501	Ceramic 180pF 50WV ± 10%		131-802-3
C502	Tantal 0.1μF 50WV ± 20%		140-106-6
C503	Elect 33μF 17WV ± 20%		103-313-9
C504	Ceramic 0.01μF 50WV + 80% / - 20%		130-102-9
C505	Ceramic 0.047μF 50WV ± 20%		130-405-3
C506	Capacitor Ceramic 0.01μF 50WV + 80% / - 20%		130-102-9
C507	Ceramic 15pF 50WV + 80% / - 20%		131-501-1
C508	Ceramic 6pF 50WV ± 10%		136-001-1
C509-C510	Not used		
C511	Tantal 1μF 16WV ± 20%		141-008-6
C512	Mica 56pF 50WV ± 5%		165-601-7
C513	Mica 47pF 50WV ± 5%		164-701-9
C514	Trimmer 20pF TZ03R200E	C-1444	172-002-4
C515	M.P 0.047μF 50WV ± 5%		194-701-8
C516	Mica 35pF 50WV ± 5%		163-501-0
C517	Elect 2.2μF 50WV ± 20%		102-207-2
C518	Ceramic 0.01μF 50WV + 80% / - 20%		130-102-9
C519	Elect 1μF 50WV ± 20%		101-006-2
C520	Not used		
C521	Elect 220μF 16WV ± 20%		102-223-6
C522	Elect 47μF 16WV ± 20%		104-712-1
C523-C524	Ceramic 0.01μF 50WV + 80% / - 20%		130-102-9
C525	Ceramic 0.047μF 50WV ± 20%		130-405-3
C526	Ceramic 18pF 50WV ± 10%		131-801-2
C527	Ceramic 22pF 50WV ± 10%		132-201-5
C528	Ceramic 39pF 50WV ± 10%		133-901-9
C529	Ceramic 0.0047μF 50WV + 80% / - 20%		130-402-0
C530	Not used		
C531	Ceramic 27pF 50WV ± 10%		132-701-0
C532	Ceramic 33pF 50WV ± 10%		133-310-7
C533	Ceramic 220μF 50WV ± 10%		132-204-8
C534	Elect 120pF 50WV ± 10%		131-202-1
C535	Elect 68μF 10WV ± 20%		106-811-7
C536	Elect 10μF 16WV ± 20%		101-012-7
C537	Ceramic 0.01μF 50WV + 80% / - 20%		130-102-9
C538-C541	M.P 0.0022μF 50WV ± 5%		192-201-3
C601-C602	Capacitor Ceramic 0.01μF 50WV + 80% / - 20%		130-101-3
C603	Elect 1000μF 16WV ± 20%		101-047-9
C604-C605	Ceramic 0.01μF 50WV + 80% / - 20%		130-102-9
COILS			
L101	27MHz, RX ANT.	CA-1337	320-380-2
L102	27MHz, RF AMP (RX)	CA-9047	320-315-4
L103	10.6MHz, RF 1st MIXER (RX)	CA-9048	320-316-5
L104	IFT 455kHz-A	CA-9049	320-154-5
L105	IFT 455kHz-B	CA-9050	320-155-6
L301-L302	27MHz, RF PRE AMP A (TX)	CA-9517	320-318-7
L303	27MHz, RF PRE AMP B (TX)	CA-9518	320-319-8
L304	27MHz, PRE AMP B (TX)	CA-9519	320-320-8
L305	AM, TX ANT, 27MHz B	CA-9514	320-033-9
L306	AM, IFT 27MHz, TX ANT	CA-9515	320-034-0
L307	AM, TX ANT, 27MHz A	CA-9513	320-032-8

Ref. No.	Description	RS Location	Mfr's Part No.
L501	VCO	CA-9516	320-317-6
RFC101	Choke 100 μ H Mold Type, Filter	CB-2583	310-096-3
RFC102	Inductor 200 μ H PC Type, Filter	CB-2682	310-136-6
RFC201-RFC202	RF Choke 0.8 μ H, Spring	CB-2680	310-072-1
RFC301	Choke, 1 μ H, Bobbin	CB-2676	310-025-9
RFC302	Inductor, 6.8 μ H, Mold Type	CB-2679	310-121-2
RFC303	Not used		
RFC304	RF Choke, 0.5 μ H, Spring	CB-2108	310-065-5
RFC501	Inductor, 6.8 μ H, Mold Type	CB-2679	310-121-2
RFC502	Choke, 100 μ H, Mold Type	CB-2583	310-096-3
RFC503	RF Choke, 20 μ H, Core	CB-2677	310-034-7
RFC601	RF Choke, 20 μ H, Core	CB-2677	310-034-7
CRYSTAL			
X1	10.240MHz, HC-18/U	CX-2010	260-003-3
DIODES			
D101-D102	1S2473, Silicon	DX-0684	243-004-3
D103	GE0A90, Silicon	DX-0576	244-003-7
D104-D107	1S2473, Silicon	DX-0684	243-004-3
D111	1S2473, Silicon	DX-0684	243-004-3
D112	GE0A90, Silicon	DX-0576	244-003-7
D113-D115	1S2473, Silicon	DX-0684	243-004-3
D201-D202	1S2473, Silicon	DX-0684	243-004-3
D203	1N4002, Silicon	DX-0206	245-001-0
D204-D206	1S2473, Silicon	DX-0684	243-004-3
D301-D302	1S2473, Silicon	DX-0684	243-004-3
D501-D505	1S2473, Silicon	DX-0684	243-004-3
D506	Not used		
D507	Not used		
D508	1S2473, Silicon	DX-0684	243-004-3
D509-D510	Not used		
D511	Varicap, MV2209	DX-1167	242-002-6
D512	Zener, UZ9.1B	DX-1978	241-020-7
D513-D514	1S2473, Silicon	DX-0684	243-004-3
D515	Zener silicon, UZ5.1B 500mW	DX-2241	241-046-1
D516-D517	1S2473, Silicon	DX-0684	243-004-3
D601	1N4002, Silicon	DX-0206	245-001-01

Ref. No.	Description	RS Location	Mfr's Part No.
FILTERS			
CF1	Ceramic, 10.7MJ	C-1442	270-010-2
CF2	Ceramic, CFU 455HT	C-1579	270-006-9
INTEGRATED CIRCUITS			
IC201	KIA2717AP, Audio	MX-4938	222-006-4
IC301	TL489CP, LED Driver	MX-6453	235-001-7
IC501	LC6526C-3220, CPU	MX-7599	224-060-2
IC502	LC7132, PLL	MX-6057	224-021-7
RESISTORS		All resistors are carbon film, 1/16W ± 5%. Unless otherwise specified.	
R100	8.2k ohm		002-182-8
R101	330 ohm		002-331-9
R102	330 ohm		002-331-9
R103	390 ohm		002-391-3
R104	1k ohm		002-102-9
R105	4.7k ohm		002-472-3
R106	270 ohm		002-271-8
R107	33k ohm		002-333-1
R108	18 ohm		002-180-9
R109-R110	Not used		
R111	18k ohm		002-183-2
R112	100 ohm		002-101-8
R113	10k ohm		002-103-0
R114	20k ohm		002-203-7
R115	220 ohm		002-221-3
R116	470 ohm		002-471-2
R117	22k ohm		002-223-5
R118	100 ohm		002-101-8
R119	100k ohm		002-104-1
R120-R121	Not used		
R122	470 ohm		002-411-2
R123	1k ohm		002-102-9
R124	10k ohm		002-103-0
R125	470 ohm		002-471-2
R126	1k ohm		002-102-9
R127	10k ohm		002-103-0
R128	2.7k ohm		002-272-9
R129-R130	Not used		
R131	220 ohm		002-221-3
R132	47 ohm		002-470-1
R133	8.2k ohm		002-822-6
R134	1M ohm		002-105-2
R135	68k ohm		002-683-7
R136	Not used		
R137	120k ohm		002-124-9
R138	100k ohm		002-104-1
R139-R140	Not used		
R141	20k ohm		002-203-7
R142	6,8k ohm		002-682-6
R143	470k ohm		002-474-5

Ref. No.	Description	RS Location	Mfr's Part No.
R144	47k ohm		002-473-4
R145	68k ohm		002-683-7
R146	4.7k ohm		002-472-3
R147	22k ohm		002-223-5
R148	33k ohm		002-333-1
R149	47k ohm		002-473-4
R150	1k ohm		002-102-9
R201	3.3k ohm		002-332-0
R202	1k ohm		002-102-9
R203	470k ohm		002-471-2
R204	820k ohm		002-824-8
R205	3.3k ohm		002-332-0
R206	220 ohm		002-221-3
R207-R208	8.2k ohm		002-822-6
R209	27k ohm		002-273-0
R210	1M ohm		002-105-2
R211	5.6k ohm		002-562-1
R212	47 ohm		002-470-1
R213	1 ohm		002-109-6
R214	22k ohm		002-223-5
R215	1.8k ohm		002-182-1
R216	470k ohm		002-474-5
R217	2.7k ohm		002-272-9
R218	100k ohm		002-104-1
R219	3.9k ohm		002-392-9
R220-R221	1k ohm		002-102-9
R222	47 ohm		002-470-1
R223	220 ohm		002-221-3
R224	4.7k ohm		002-472-3
R225	10k ohm		002-103-01
R226	4.7k ohm		002-472-3
R227	8.2k ohm		002-822-6
R228	10k ohm		002-103-0
R229-R230	Not used		
R231	330 ohm		002-331-9
R232	2.2k ohm		002-222-4
R233	22k ohm		002-223-5
R234	Metal Oxide 22 ohm 2W \pm 5%		019-220-0
R235	Carbon Film 33k ohm 1/2W \pm 5%		002-333-1
R301	390 ohm		002-391-3
R302	150k ohm		002-154-6
R303-R305	4.7k ohm		002-472-3
R306	68 ohm		002-680-4
R307	100 ohm		002-101-8
R308	1k ohm		002-102-9
R309-R310	Not used		
R311	100 ohm		002-101-8
R312	3.3 ohm		002-339-7
R313	Carbon Film 10 ohm 1W \pm 5%		018-100-0
R314	1.2k ohm		002-122-7
R315	1k ohm		002-102-9
R316	150 ohm		002-151-3

Ref. No.	Description	RS Location	Mfr's Part No.
R317-R320 R321	1.5k ohm Carbon Film 4.7k ohm 1/2W ±5%		002-152-4 012-472-6
R501-R514 R515-R518 R519 R520 R521 R522-R524 R525 R526 R527 R528 R529-R530 R531 R532 R533 R534-R536 R537 R538 R539-R540 R541 R542 R543 R544-R545 R546 R547 R548 R549-R550 R551 R552 R553 R554-R555 R556 R557 R558 R559-R560 R561-R562 R563	2.2k ohm 15k ohm 3.3k ohm 8.2k ohm 10k ohm 56k ohm 22 ohm 470 ohm 10k ohm 1/17W ±5% 33k ohm Not used 2.2k ohm 82k ohm 22k ohm 10k ohm Not used 22 ohm Not used 470 ohm 100 ohm Not used 10k ohm 4.7k ohm 10k ohm 47k ohm Not used 820 ohm 100k ohm 220k ohm 2.7k ohm 33 ohm 18k ohm 1M ohm Not used 18k ohm 2.2M ohm		002-222-4 002-153-5 002-332-0 002-822-6 002-103-0 002-563-2 002-220-2 002-471-2 002-103-0 002-333-1 002-222-4 002-823-7 002-223-5 002-103-0 002-220-2 002-471-2 002-101-8 002-103-0 002-472-3 002-103-0 002-470-1 002-821-5 002-104-1 002-224-6 002-272-9 002-330-8 002-183-2 002-105-2 002-183-2 002-225-7
VARIABLE RESISTORS			
RV101, RV201 RV202	Semifixed, B20k ohm φ8, ±25% Semifixed, B2k ohm, φ8, ±25%	P-6989 P-7557	061-203-0 061-202-9
RV301	Semifixed, B20k ohm, φ8, ±25%	P-6989	061-203-0
VR101 VR102	Without/SW, B50k ohm ±20% With/OFF-ON SW, A50k ohm ±20%	P-8073 P-8074	450-601-2 450-602-3
VR201	With/DPDT SW, B10k ohm ±20%	P-8075	450-403-0

Ref. No.	Description	RS Location	Mfr's Part No.
SWITCH			
SW509	K121 D110-5NH 312, CH Up-Down		439-005-3
TRANSFORMERS			
T201	Output or	TB-0578	300-115-4 or
	Output		300-022-3
T601	Choke or	TB-0577	300-116-5 or
	Choke		300-008-1
TRANSISTORS			
Q100-Q101	KTA562TM(Y) PNP Silicon or MPS9468A(T) PNP Silicon	1TR-0220	202-054-2 203-041-4
Q102-Q104	KTC1923(O) NPN Silicon or MPS9426(C) NPN Silicon	2SC-19230	202-017-8 203-005-2
Q105	KTC1923(Y) NPN Silicon or MPS9623(I) NPN Silicon	2SC-1923	202-060-7 203-012-8
Q106	KTC1923(Y) NPN Silicon or MPS9623(H) NPN Silicon	2SC-1923	202-060-7 202-060-7
Q107	KTC1815(GR) NPN Silicon or MPS9623(I) NPN Silicon	2SC-1815GR	202-023-3 203-012-8
Q201	KTC1815(GR) NPN Silicon or MPS9631(T) NPN Silicon	2SC-1815-GR	202-023-3 203-014-0
Q202	KTA1015(Y) PNP Silicon or MPS9681(T) PNP Silicon	2SA-1015Y	202-036-5 203-009-6
Q203-Q205	KTC1815(GR) NPN Silicon or MPS9634(C) NPN Silicon	2SC-1815GR	202-023-3 203-002-9
Q206-Q207	KTA1015(GR) PNP Silicon or MPS9681(T) PNP Silicon	2SA-1015	202-036-5 203-009-6
Q208-Q209	KTC1815(GR) NPN Silicon or MPS9634(C) NPN Silicon	2SC-1815GR	202-023-3 203-009-6
Q301-Q302	KTC1923(O) NPN Silicon or MPS9426(C) NPN Silicon	2SC-19230	202-017-8 203-005-2
Q303	KTC2036A NPN Silicon or 2SC2314(E) NPN Silicon	2SC-2314	202-058-6 204-016-7
Q304	KTC2075 NPN Silicon or 2SC2078(D) NPN Silicon	2SC-2075	202-057-5 204-009-1
Q501	KTA1015(GR) PNP Silicon or MPS9681(T) PNP Silicon	1TR-0223	202-036-5 203-009-6
Q502	KTC1959(O) NPN Silicon or MPS9418(T) NPN Silicon	2SC-19590	202-056-4 203-010-6
Q503	KTA1015(GR) PNP Silicon or MPS9681(T) PNP Silicon	2SA-1015	202-036-5 203-009-6
Q504-Q505	KTC1923(O) NPN Silicon or MPS9426(C) NPN Silicon	2SC-19230	202-017-8 203-005-2
Q506-Q507	KTC1815(GR) NPN Silicon or MPS 9634(C) NPN Silicon	2SC-1815GR	202-023-3 202-002-9
Q508	KTA1015(GR) PNP Silicon or MPS9681(T) PNP Silicon	2SA-1015	202-036-5 203-009-6
Q509	KTC1815(GR) NPN Silicon or MPS9418(T) NPN Silicon	2SC-1815GR	202-023-3 203-010-6
Q510	KTC1815(O) NPN Silicon or MPS9631(T) NPN Silicon	2SC-1815O	202-020-0 203-009-6

Ref. No.	Description	RS Location	Mfr's Part No.
LED DISPLAY & SW PCB ASS'Y		XB-1704	593-006
LED501 SW501-SW507 SW508 D303-D306	L E D Display (RED) Touch EVQ-QSR-05K (Switch) SPH 221A (Switch) L E D Lamp, SLB26UR3HL (RED)	L-2120 S-3037 S-3669 L-1833	252-017-3 434-003-6 432-040-6 251-016-7
POWER CORD ASS'Y			504-255
	Fuse 250V/1A Fuse 250V/2A Power Cord 1,500m/m RED Power Cord 1,500m/m ORG Power Cord 1,500m/m BLK		280-015-0 280-006-2

SEMICONDUCTOR LEAD IDENTIFICATION AND IC INTERNAL DIAGRAM

INTEGRATED CIRCUITS

IC 201 KIA7217AP

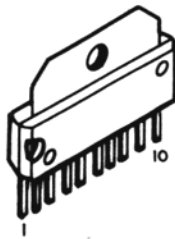

IC 501 LC6526C

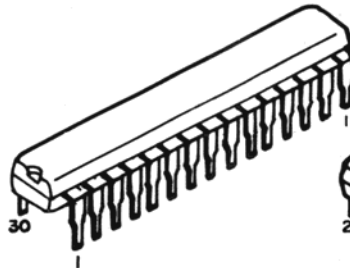

IC 502 LC7132

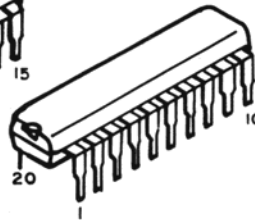

IC 301 TL489CP



TRANSISTORS

- MPS 9623
- MPS 9631
- MPS 9634
- MPS 9681
- MPS 9418
- MPS 9468



- KTA 5621
- KTA 1015
- KTC 1815
- KTC 1959



- MPS 9426
- KTC1923



- 2SC2314
- KTC2036



- 2SC2078
- KTC2075



DIODES

- IN4002
- IS2473
- OA90
- IN60

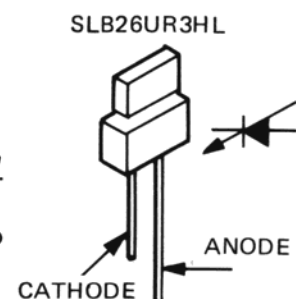
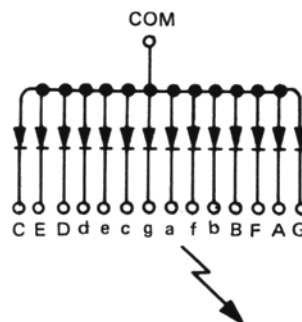
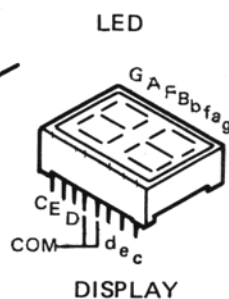
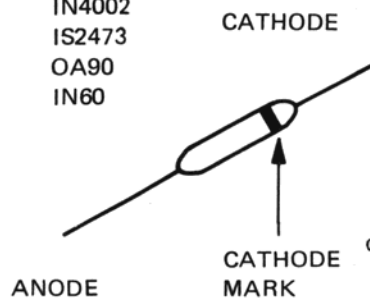

MV2209



IC201 KIA7217AP

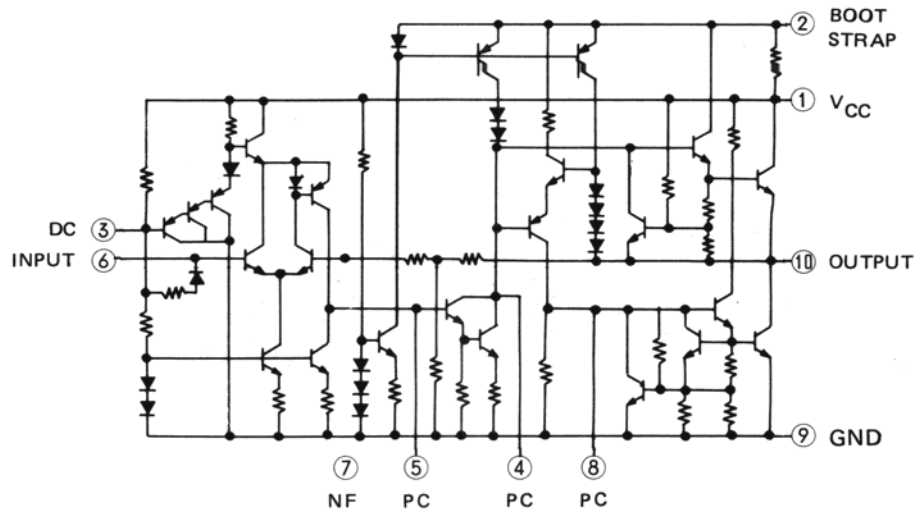

DC: Decoupling
PC: Phase compensation

IC301 TL489CP

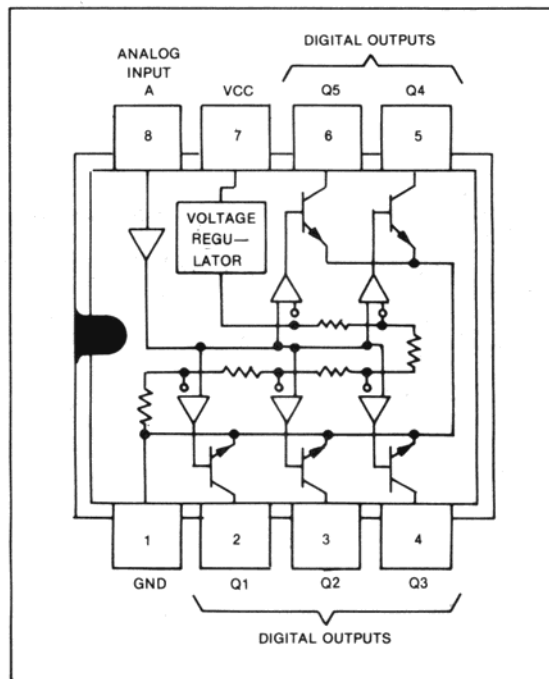

IC501 LC6526C

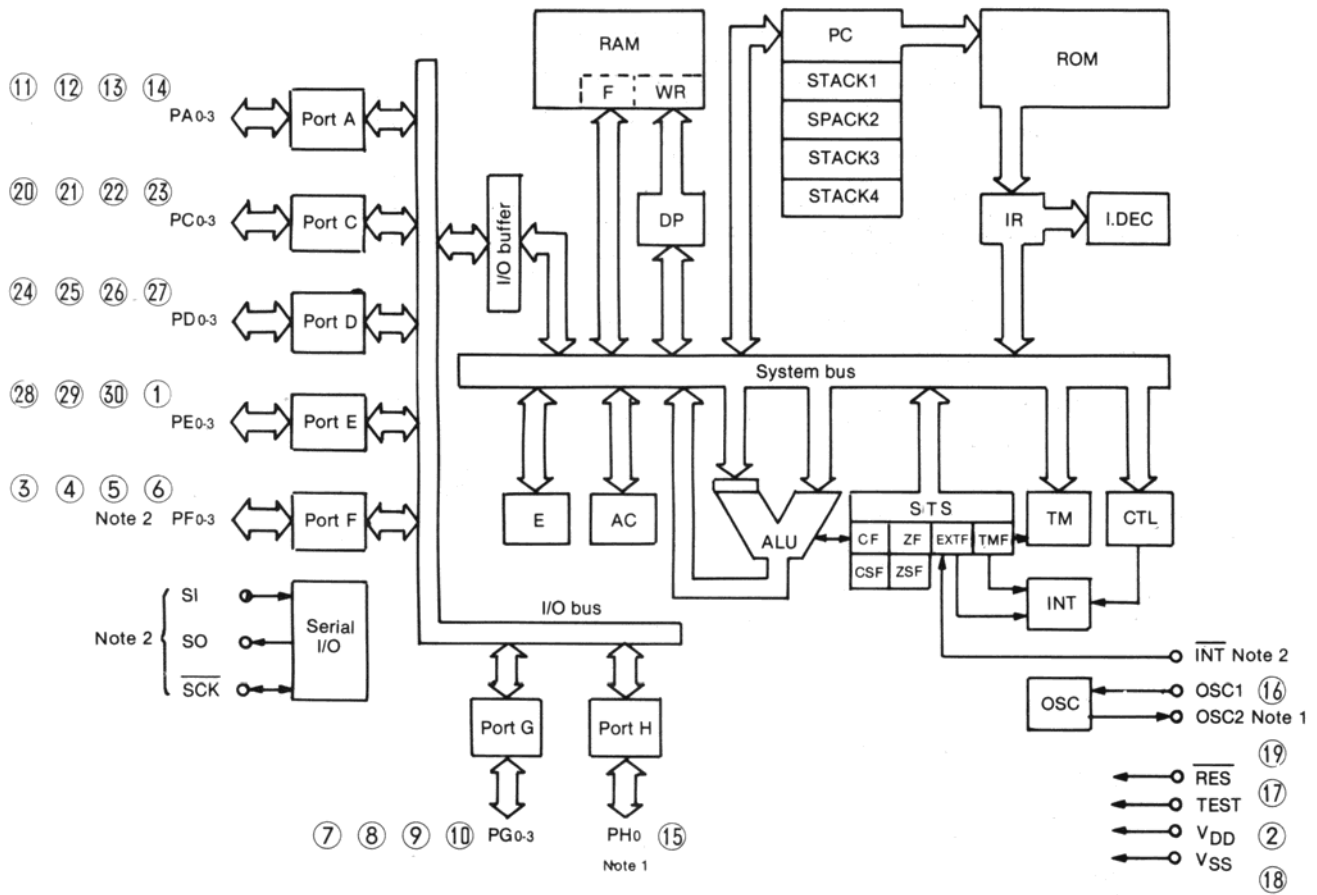

- | | |
|---------------------------------|--|
| RAM : Data memory | ROM : Program memory |
| F : Flag | PC : Program counter |
| WR : Working register | INT : Interrupt control |
| AC : Accumulator | IR : Instruction register |
| ALU : Arithmetic and logic unit | I.DEC : Instruction decoder |
| DP : Data pointer | CF,CSF : Carry flag, carry save flag |
| E : E register | ZF,ZSF : Zero flag, zero save flag |
| CTL : Control register | EXTF : External interrupt request flag |
| OSC : Oscillator | TMF : Internal interrupt request flag |
| TM : Timer | |
| STS : Status register | |

IC502 LC7132

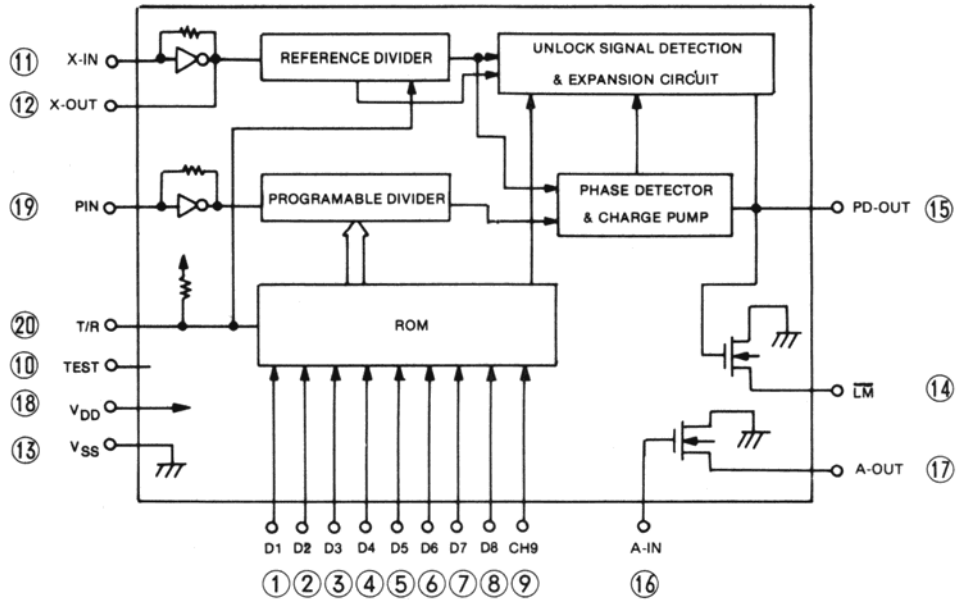

- D1 to D8 : Program input (7 segment code)
- X_{IN}, X_{OUT} : Amplifier for crystal oscillator
- V_{DD}, V_{SS} : Power Supply
- LM : Lock monitor output, Lock = open or 1, Unlock = "0"
- PD_{OUT} : Charge dump output
- A_{IN}, A_{OUT} : Amplifier for low-pass filter
- PIN : Programable divider input
- T/R : Transmission/reception change over input
 $\overline{T/R} = "0"$ – Transmission, $\overline{T/R} = "1"$ – reception
- CH9 : Channel 9 select input
- TEST : LSI test pin (Connected to V_{SS} or open)

TRANSISTOR AND IC VOLTAGE CHART

MEASURED AT;

1. 19CH
2. No Signal
3. No Modulation

TRANSISTORS

TRANSISTOR NUMBER	EMITTER		BASE		COLLECTOR	
	RECEIVE	TRANSMIT	RECEIVE	TRANSMIT	RECEIVE	TRANSMIT
Q100	3.8	2.2	5.6	1.5	5.6	1.5
Q101	3.8	2.2	5.6	1.5	0.6	2.2
Q102	0.1	0	0.8	0.45	6.4	0.82
Q103	0.17	0	0.85	0	13.2	12.66
Q104	0.18	0	0.8	0.5	5.54	0.6
Q105	0.23	0	0.92	0.41	5.76	0.82
Q106	0.58	0	1.3	0.16	13.47	12.68
Q107	0	0	0.32	0.07	5.51	1.45
Q201	0	0.82	0.32	1.47	0.35	6.4
Q202	13.76	12.8	13.7	12.08	0.32	12.77
Q203	0	0	0.5	0.37	0.65	0.65
Q204	0	0	0.66	0.66	0.05	0.05
Q205	0	0	0	0	0	0
Q206	13.72	13.45	13.72	12.7	0.4	13.4
Q207	0.41	4.1	1.02	4.68	0	0
Q208	0	0	0	0	0	0
Q209	1.1	0.04	1.64	0.2	1.15	0.47
Q301	0	1.24	0	1.87	0	8.36
Q302	0	1.13	0	1.85	13.57	12.86
Q303	0	0	0	0	13.8	11
Q304	0	0	0	0	13.8	11.8
Q501	3.24	3.22	4.6	4.56	0	0
Q502	8.46	8.39	9.2	9.15	12.85	12.14
Q503	8.46	8.39	8.45	7.7	0	8.35
Q504	0	0	0.76	0.76	2.85	2.78
Q505	3.69	0.16	4.26	4.24	8.09	8.03
Q506	0	0	0	0.68	0.12	0
Q507	0	0	0.5	0.36	0.0	0
Q508	4.28	4.35	4.26	4.28	0.34	0.31
Q509	4.28	4.35	4.86	4.86	12.98	12.90
Q510	0	0	0.37	0.32	8.31	8.20

ICs

IC	PIN No.	VOLTAGE		IC	PIN No.	VOLTAGE		IC	PIN No.	VOLTAGE	
		RX	TX			RX	TX			RX	TX
IC 201	1	13.72	13.43	IC 502	1	0.25	0.24	IC 501	1	12.38	11.88
	2	12.54	12.25		2	0.25	0.24		2	4.27	4.27
	3	3.94	3.85		3	0.26	0.25		3	0.53	0.5
	4	8.12	7.98		4	12.5	12.20		4	0.52	0.5
	5	1.47	1.45		5	0.27	0.26		5	0.51	0.5
	6	3.36	3.17		6	0.28	0.27		6	0.52	0.5
	7	3.38	3.33		7	12.49	12.20		7	12.28	11.83
	8	1.25	1.13		8	12.49	12.21		8	12.30	11.85
	9	0	0		9	0	0		9	4.24	4.26
	10	6.85	6.72		10	0	0		10	0	0
IC 301	PIN No.	VOLTAGE		IC 502	11	3.64	3.61	IC 501	11	0.03	0
		RX	TX		12	3.85	3.82		12	0.03	0.02
	1	0	0		13	0	0		13	0.03	0.02
	2	12.32	0.04		14	0	5.11		14	0	8.35
	3	12.35	0.03		15	1.57	1.6		15	0.17	0.23
	4	12.35	11.85		16	1.57	1.6		16	1.99	1.97
	5	12.32	11.85		17	2.15	1.62		17	0	0
	6	0.3	0.7		18	8.26	8.2		18	0	0
	7	12.72	12.01		19	3.95	3.91		19	2.9	2.7
	8	0	0.48		20	6.27	0.81		20	0.25	0.24
									21	0.25	0.24
									22	0.26	0.25
									23	12.27	11.95
									24	0.27	0.26
									25	0.28	0.27
									26	0.28	0.27
									27	0.28	0.27
									28	12.25	12.18
									29	12.21	12.0
									30	0.29	0.28

RADIO SHACK
A Division of Tandy Corporation
Fort Worth, Texas 76102