

**INSTRUCTION
MANUAL
SP 102P**

Y A U M U N O

PHONE PATCH/SPEAKER SP-102P

GENERAL

The YAESU model SP-102P Phone Patch/Speaker is designed to be used with the FT-102 series HF transceiver, providing hybrid phone patch operation as well as an external speaker unit.

All the operating controls are conveniently located on the front panel of the compact housing, which matches the FT-102 series in styling. Jacks are provided on the rear panel for making the necessary external connections.

INSTALLATION

Installation of this unit consists of connecting the telephone line to the jack marked LINE, and making the other interconnections shown in the drawings.

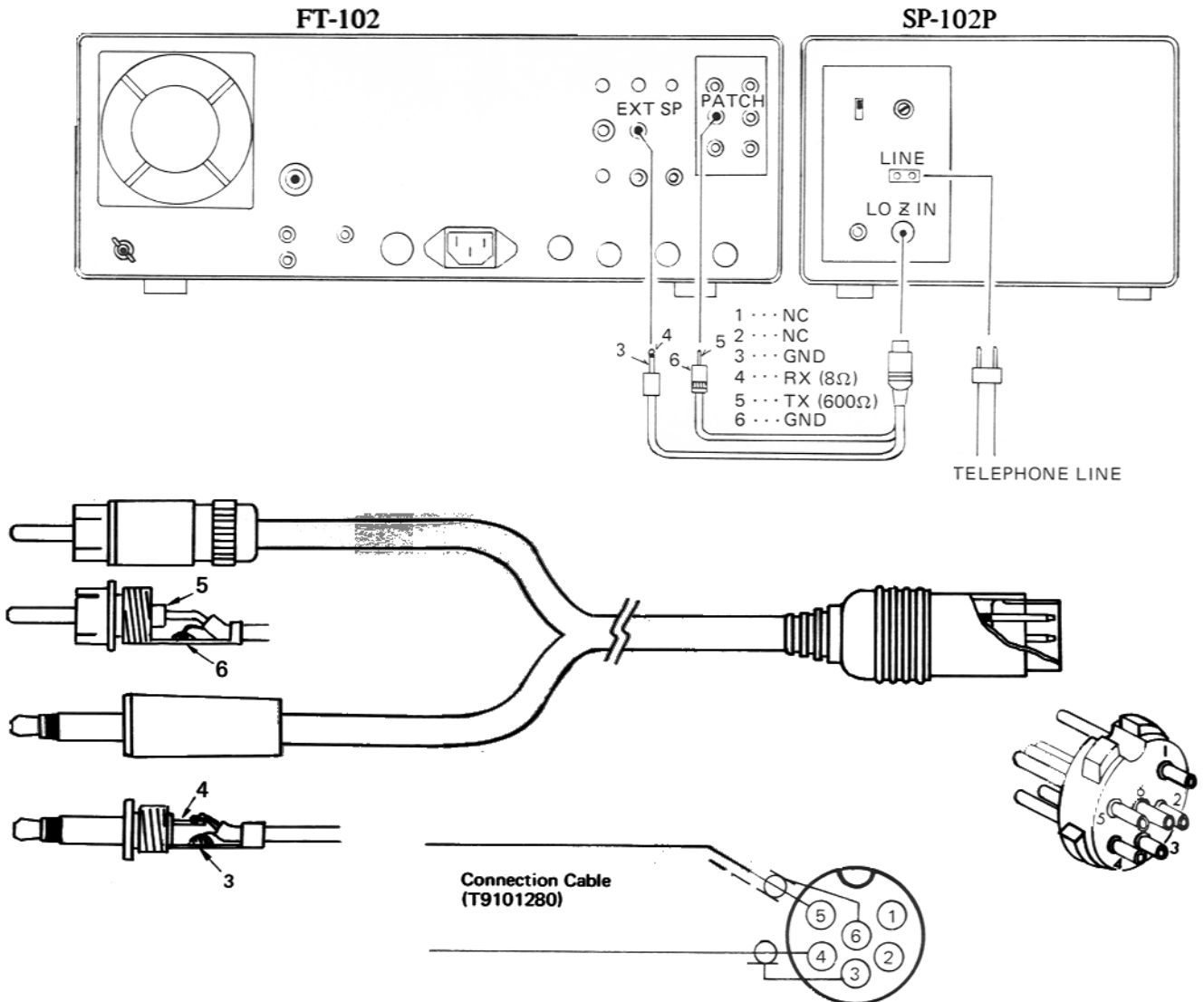

FRONT PANEL CONTROLS



(1) PATCH Switch

In the "ON" position, the hybrid circuit is connected to the phone lines and transceiver is ready for phone patch operation. The built-in speaker is disconnected. When this switch is placed in the "OFF" position, the phone patch is disconnected from the phone lines, and the built-in speaker is connected to the transceiver.

(2) TX GAIN Control

This potentiometer controls the amplitude of the phone signal fed to the microphone input of the transceiver.

(3) PHONES

This standard 1/4-inch phone jack accepts your headphone plug.

(4) RX GAIN Control

This potentiometer controls the amplitude of the received signal fed to the phone lines.

(5) METER

The meter indicates the signal level fed to the phone lines from the transceiver while on receive. The meter also is used to measure the balance for the hybrid circuit, in conjunction with the MONITOR/NUL switch and the BALANCE control on the rear panel.

REAR APRON

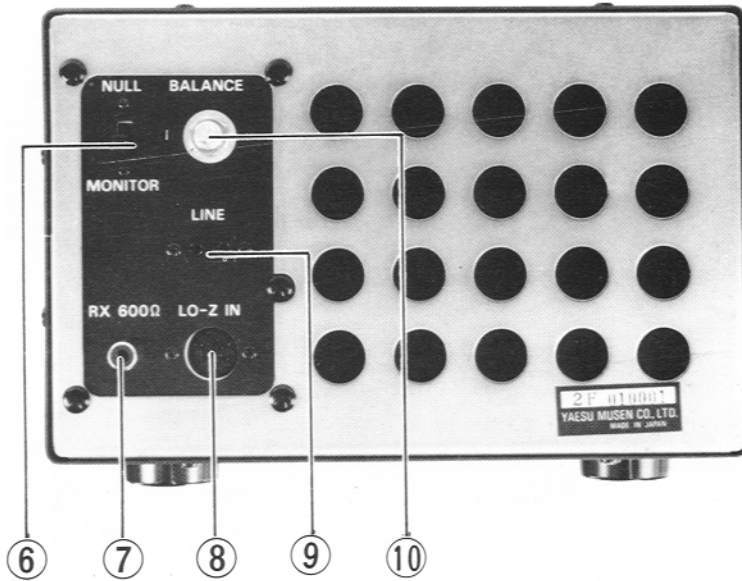

(6) MONITOR/NULL switch

This switch is placed in the NULL position while adjusting the balance of the hybrid circuit.

It must be in the MONITOR position for phone patch operation. In this position, the meter will indicate the signal level fed to the phone lines from the transceiver.

(7) RECEIVER 600 Ohm jack

This jack is used with receivers of 600 ohm audio output impedance.

(8) LOW-Z IN jack

Through the LOW-Z IN jack, connections for the speaker output and the microphone input to the FT-102 transceiver are accomplished.

(9) LINE jack

This jack is used for connection to the telephone lines.

(10) BALANCE control

This control is used to null the receiver audio output, thus providing isolation between the receiver audio and the microphone input.

OPERATION

Phone Patch operation may be performed either manually, using the PTT (push-to-talk) method, or automatically using the VOX (voice actuated transmit) circuit in the FT-102. While the manual method does not require balance adjustment of the bridge circuit in the SP-102P, it does necessitate the manual PTT switching (via the MOX switch or PTT) by the phone patch operator at each "over" during the patched conversation. Therefore, most operators prefer to use the VOX method for phone patching whenever possible. This requires that the bridge circuit in the SP-102P be balanced according to the Null Alignment described below, and that the telephone line signal be of good quality, free from noise and distortion. The telephone line impedance should be 600 ohms. When these conditions can not be met, the manual phone patch method must be used.

Before commencing phone patch operation, request the person on the telephone to speak in a clear, normal voice, and to use the word "over" whenever they finish speaking and expect a response from the other radio station (if they are unfamiliar with phone patch conversation). This will serve as notice to switch the FT-102 to receive (if operating with the manual method), and will help prevent "doubling" with the other station if using the VOX method.

During all phone patch operation the patch operator should monitor both sides of the conversation at all times (usually required by law). This can be done using a telephone at the operating position.

Manual Phone Patch Operation

1. With the FT-102 set for normal reception of the station for whom the patch is being made, set the VOX GAIN, DELAY, and MIC GAIN controls all fully counterclockwise. On the SP-102P, preset the RX GAIN and TX GAIN controls to their 12 o'clock positions.

Bring the telephoned party onto the line, and after instructing them about phone patch operation ask them to please stand by.

3. Switch the SP-102P ON, and set the AF GAIN control on the FT-102 to the 10 o'clock position. Now adjust the RX GAIN control on the SP-102P for a comfortable volume in the telephone receiver.
4. To transmit, depress the MOX switch or close the PTT and advance the MIC GAIN control on the FT-102 while speaking into the telephone and watching the ALC indication on the FT-102 to obtain a normal ALC level (as in regular SSB operation). Invite the person on the telephone to speak (now over the air), and repeat the MIC GAIN slightly for optimum ALC indication. Remember to switch back to receive when they say "over".

Null Alignment

1. With the SP-102P switched OFF, preset the RX GAIN and TX GAIN controls fully clockwise. Set the NULL/MONITOR switch on the rear panel to NULL.
2. On the rear panel of the FT-102, set the MARKER switch ON, and tune the VFO to obtain a 1 kHz tone from the marker. (This can be done by setting the MODE selector to CW, the APF button to ON and the APF frequency control to the 12 o'clock position. Now tune the VFO for a peak volume on the marker heterodyne.)
3. Set the VOX GAIN control on the FT-102 fully counterclockwise, and lift the telephone handset from the cradle. Switch the SP-102P ON/OFF switch to ON, and advance the AF GAIN control on the FT-102 fully clockwise (maximum).
4. Adjust the BALANCE control on the rear panel of the SP-102P to obtain minimum deflection on the meter of the SP-102P.
5. Switch the MARKER on the FT-102 OFF and reduce the AF GAIN control to the 10 o'clock position. Return the NULL/MONITOR switch on the rear of the SP-102P to the MONITOR position.

Voice Controlled Operation (VOX)

Before beginning VOX operation of the phone patch, perform the preceding Null Alignment procedure and set up the FT-102 for SSB operation with VOX as described on page 25 of the FT-102 Instruction Manual. Once this has been done, follow the same procedure as for manual operation, advancing the VOX GAIN control on the FT-102 just to the point where the voice of the person on the telephone will activate the transmitter (instead of using the MOX or PTT switch). Now adjust the DELAY control for stable transmission and return to reception after they stop speaking. Adjust the A-TRIP control on the rear panel of the FT-102, if necessary, to prevent the received signal from keying the VOX circuit (and activating the transmitter) when the person on the telephone is not speaking.

If difficulty is encountered in obtaining the correct setting of the VOX GAIN and A-TRIP controls for smooth operation, set the NULL/BALANCE switch on the rear panel of the SP-102P to the NULL position, and again adjust the BALANCE control slightly for minimum meter deflection while receiving the signal from over the air. If the instability persists, reduce the AF GAIN control on the FT-102 slightly.

Modification for High Impedance Microphone Input

If the SP-102P is to be used with a transceiver that requires a high impedance microphone (such as the FT-101/B/E/F transceivers), change the jumper wire connection as shown in the diagram and according to the following steps:

- a) Remove the TX GAIN control knob, and the nut and washer holding the potentiometer.
- b) Remove the two screws affixing pc-board PB-2397.
- c) Slide PB-2397 toward the back of the chassis, and change the jumper wire connection as shown.
- d) Replace PB-2397 and its two screws, and then the TX GAIN potentiometer nut, washer and knob.

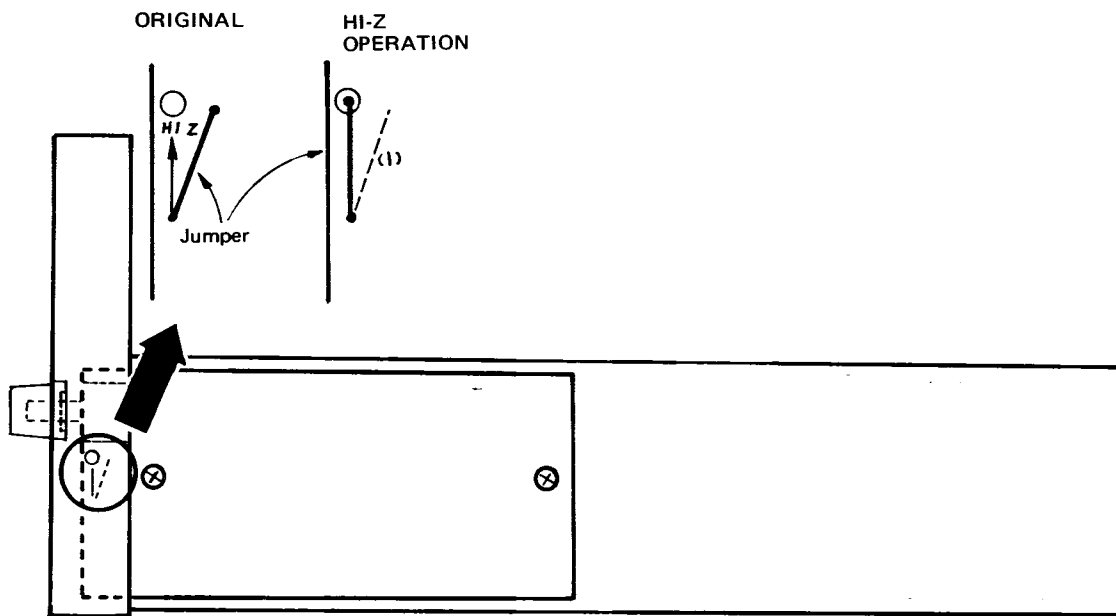

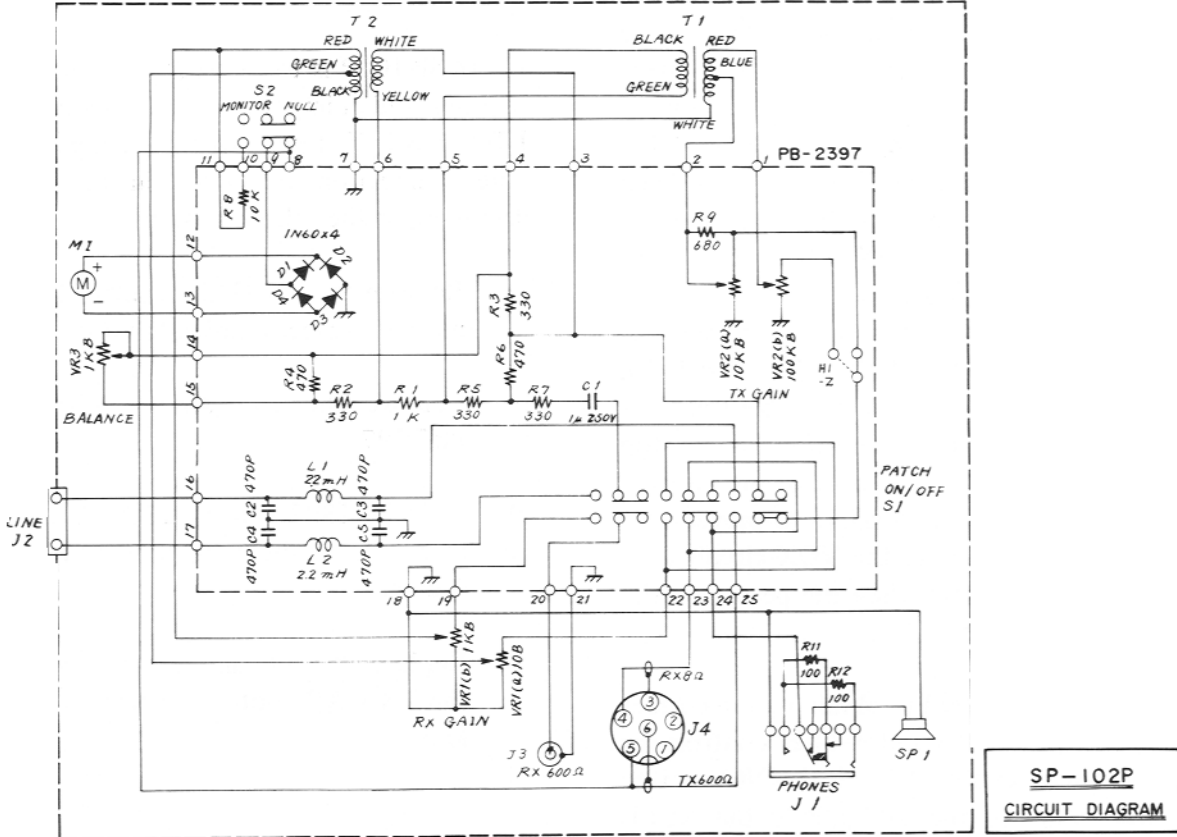

SP-102P
CIRCUIT DIAGRAM

PARTS LIST

Symbol Number	Part Number	Description			METER
			M1	M0290001	KTC-012
PB-2397	F0002397	P.C. Board			
	C0023970	P.C. Board with Components			
			SP1	M4090056	SPEAKER SE-120AF 8Ω 3W
		DIODE			
D1-4	G2090029	Ge 1N60			SWITCH
			S1	N4090064	
		RESISTOR			TERMINAL BOARD
R11,12	J01275101	Carbon Film 1/2W TJ 100Ω	SQ1	Q9000212	(VR3, J2, J3, J4, S2)
	J01275331	" " " " 330Ω	VR3		Potentiometer 1KΩB (N246)
	J01275471	" " " " 470Ω	J2		2P Jack (TD532)
	J01275102	" " " " 1kΩ	J3		RCA Phono Jack
	J01275103	" " " " 10kΩ	J4		6P DIN Jack (MJ54)
		" " 1/4W SJ 680Ω	S2		Slide Switch (OS-22-09)
					Plastic board
		POTENTIOMETER			
VR1	J61800014	VR 1KB / 10B			PHONES JACK
VR2	J61800015	" 10KB / 100KB	J1	P1090134	SG-7627
				Q5000025	Wrapping Terminal A
		CAPACITOR			
C2-5	K10176471	Ceramic disc 50V 470pF			
C1	K52240001	Metallized Polyester Film 250WV 1μF			ACCESSORIES
					Plug
			P1	P0090018	STP-58
			P3	P0090005	SI-7502
L1,2	L1190034	FL7H222J 2.2mH	P4	P0090032	E6-701B-02
			P5	P0090034	P-2240
		TRANSFORMER			
T1	L2030073				
T2	L2030074				



YAESU