

INSTRUCTION MANUAL FC-700

SCHEMATHEEK

Beh. T. Hultermans

Postbus 4228

5604 EE Eindhoven

YAESU MUSEN CO., LTD.

C.P.O. BOX 1500

TOKYO, JAPAN

YAESU FC-700 ANTENNA COUPLER



GENERAL

The FC-700 is an ultra-compact antenna tuner for the FT-77 transceiver. Designed for operation on the 80 through 10 meter amateur bands (including WARC bands), the FC-700 will provide a 50-ohm load to the transceiver when the feedpoint impedance of the antenna system is within the approximate range of 10 ohms to 250 ohms.

The FC-700 includes a built-in SWR and power meter, providing 15 watt and 150 watt scales. Also included is an internal 50-ohm dummy load, which may be selected instead of the antenna for preliminary coupler adjustments. A THRU position of the bandswitch also allows the antenna to be connected directly to the transceiver, bypassing the tuning circuit.

High-quality low-loss components are used throughout the FC-700. The matching function it performs means the transmitter can always "see" the resistive termination for which it was designed. The inherent selectivity of the FC-700 matching circuitry helps attenuate harmonics too, thus reducing the chance of harmonic-related TVI or out-of-band emissions.

Please read this manual in its entirety, so as to derive maximum benefit from your new FC-700.

SPECIFICATIONS

Frequency coverage:

3.5	3.5–4.0 MHz
7	7.0–7.5 MHz
10	10.0–10.5 MHz
14	14.0–14.5 MHz
18	18.0–18.5 MHz
21	21.0–21.5 MHz
24.5	24.5–25.0 MHz
28	28.0–29.7 MHz

Input impedance:

50 ohms

Max. variation in load impedance:

approx. 10–250 ohms

Maximum transmitter power:

150 W RF @ 50 ohms

Power meter calibration scales:

15 W, 150 W

Insertion loss:

0.5 dB max.

Rear panel antenna connection:

UHF type connector

Dimensions:

238(W) x 55(H) x 180(D) mm

Weight:

2.0 kg

SWR calibration:

To 5:1 SWR

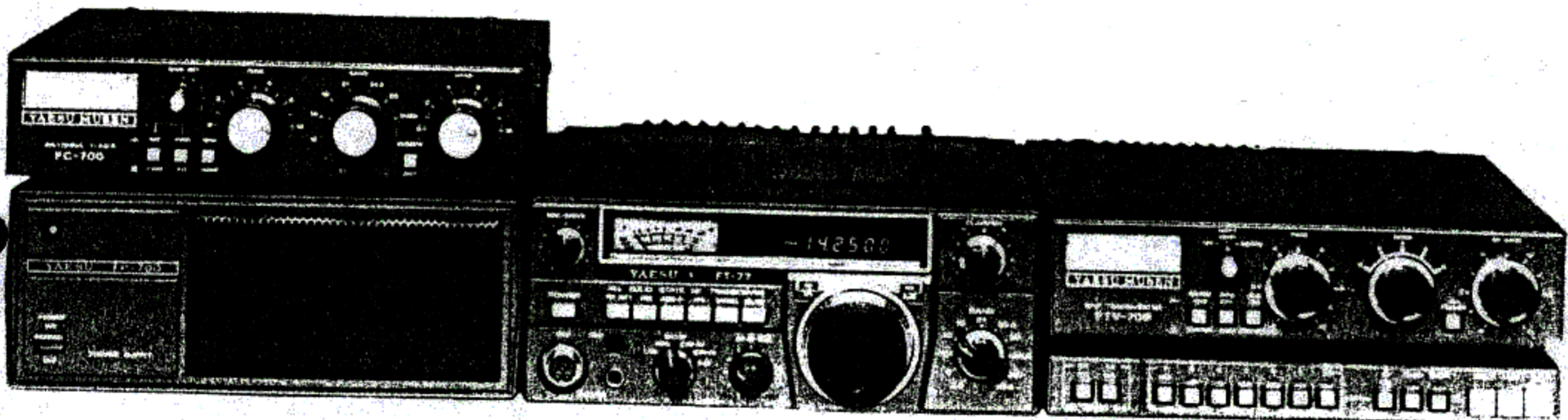

FP-700/FC-700/FT-77/FV-700DM/FTV-700

FRONT PANEL CONTROLS AND SWITCHES

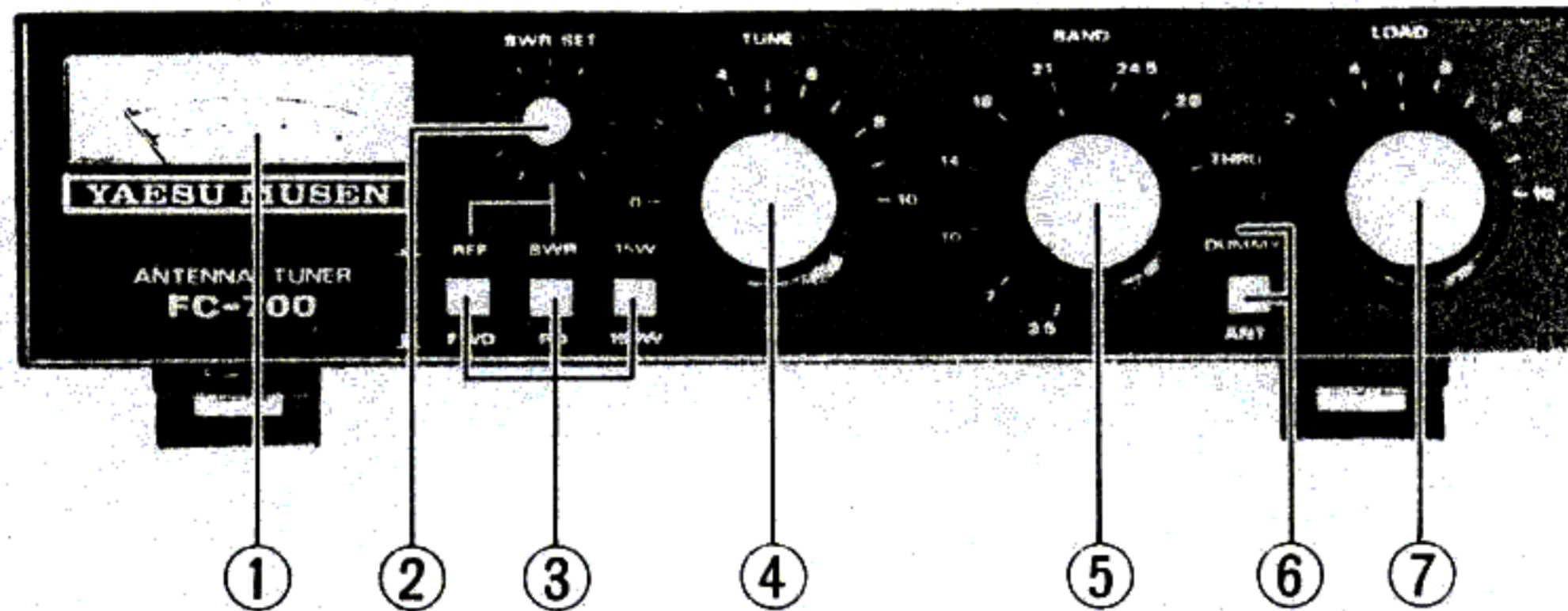

(1) Meter

The meter provides indication of the SWR or power level.

(2) SWR SET

This control sets the sensitivity of the SWR meter.

(3) Function Switches

REF/FWD This switch selects forward or reflected power indication on the meter.

SWR/PO This switch selects indication of the SWR or power output on the meter.

15W/150W This switch selects indication of the output power level scales: 15 or 150 watts full scale.

(4) TUNE

The TUNE control drives a variable capacitor which provides capacitive adjustment of the coupling between the transmitter and the impedance

established by the BAND switch and LOAD control. The TUNE and LOAD controls are adjusted for minimum SWR.

(5) BAND

The BAND selector selects the appropriate tap on the main tuning inductor for the band in use.

(6) DUMMY/ANT

This switch selects either the antenna or connection to the 50-ohm dummy load. When the built-in dummy load is selected, the antenna coupler tuning controls are still in the line, so preliminary adjustment of the coupler can be performed. When this button is pressed and the BAND selector is set to the THRU position, only the dummy load and meter remain in the circuit.

(7) LOAD

The LOAD control drives a variable capacitor which adjusts the coupling between the antenna feedline and the main BAND inductor.

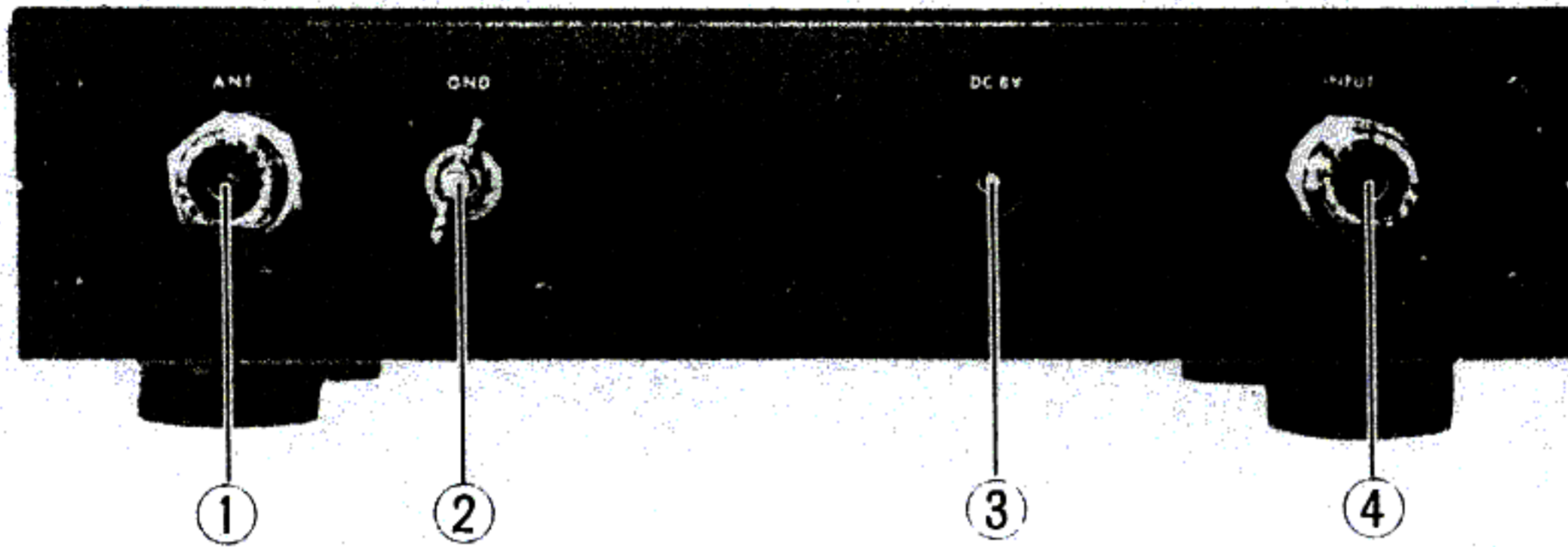

(1) ANT

This is a standard UHF connector for the antenna feedline.

(2) GND

Connect a good earth ground at this point.

(3) DC 8V

The DC8V line from the FT-77 transceiver should

be connected here, to supply the meter lamp on the front panel of the FC-700.

(4) INPUT

Connect the coaxial cable to the FT-77 ANT jack at this point.

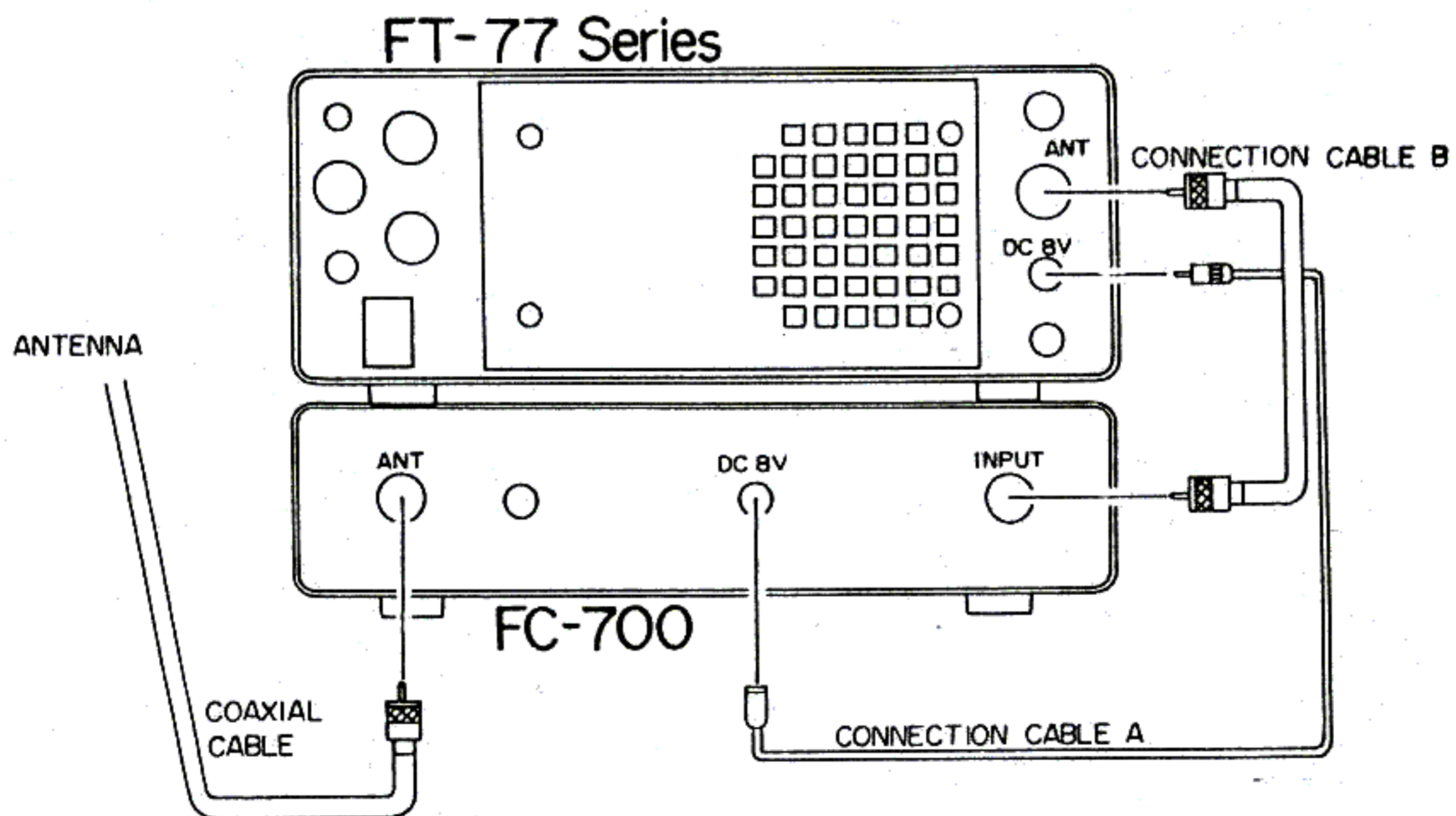

INSTALLATION

Connect the antenna to the rear panel ANT jack, and connect a 50-ohm coaxial cable between the FT-77 and the FC-700. Connect the DC cable between the DC8V jacks of the FC-700 and the FT-77. Connect a good earth ground to the GND terminal on the rear of the antenna coupler, using a heavy, braided wire less than 10 feet long for connection to the station ground bus.

When using a transceiver other than the FT-77, be absolutely certain to observe the proper polarity and level of the voltage applied to the rear panel DC8V jack. Do not exceed 8 volts DC, nor apply AC power of any kind, to this jack. Our warranty does not cover damage caused by improper power connections to this equipment.

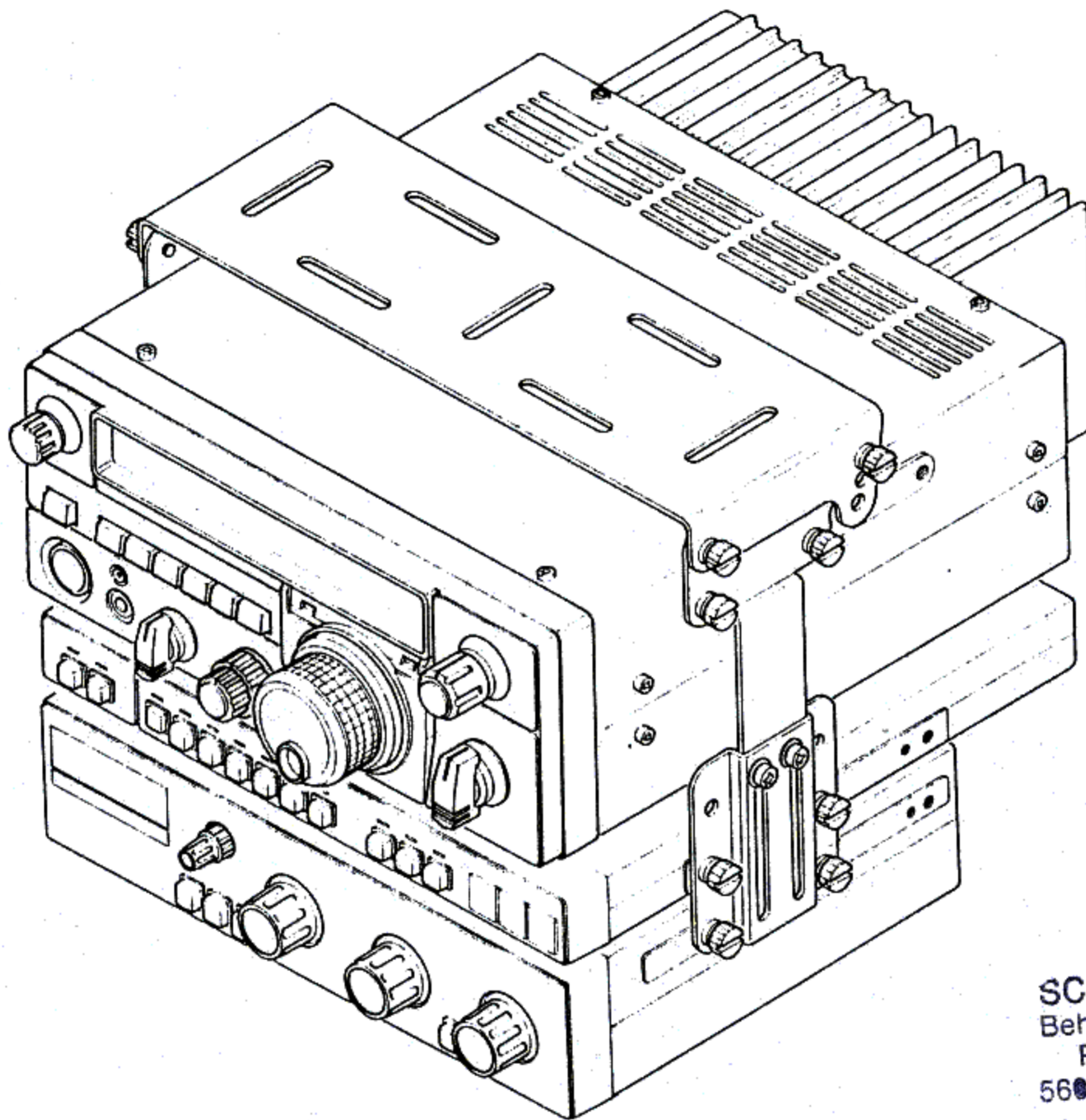

SCHEMATHEEK
Beh. T. Hultermans
Postbus 4228
5604 EE Eindhoven

FT-77/FV-700DM/FC-700 (or FTV-700)/MMB-16

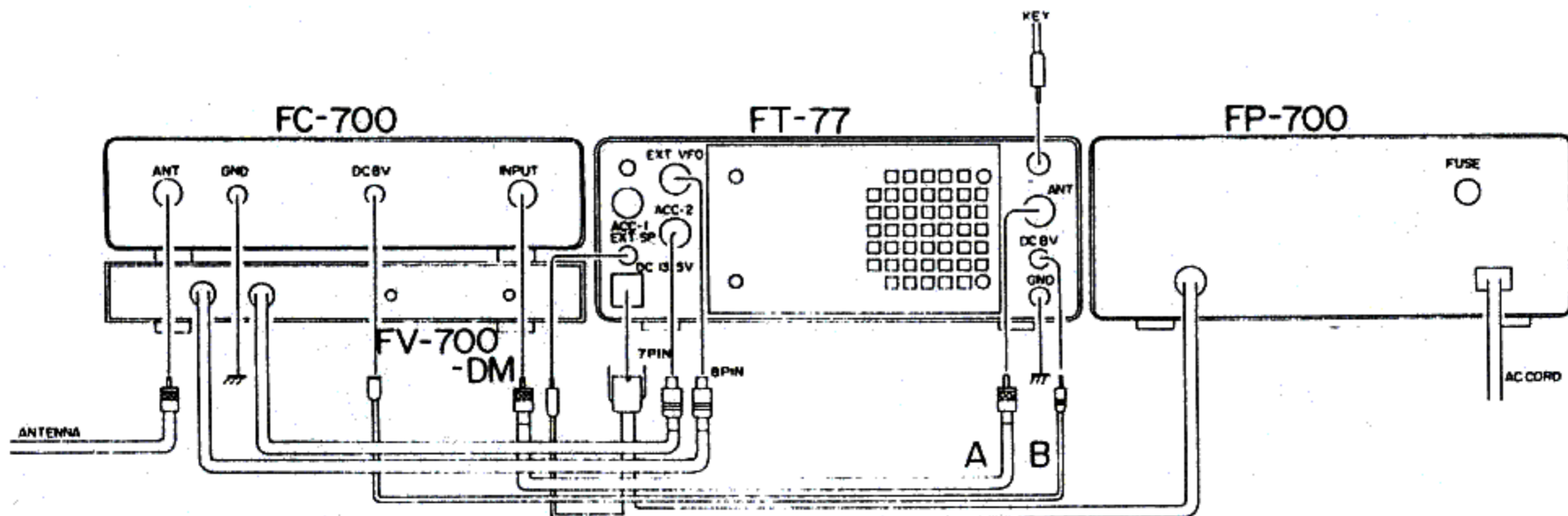

ANTENNA MATCHING PROCEDURE

THIS SECTION SHOULD BE STUDIED CAREFULLY BEFORE USING THE FC-700. WHILE A STRAIGHTFORWARD PROCEDURE, ANTENNA MATCHING WITH A COUPLER SUCH AS THE FC-700 INVOLVES A LOGICAL PROGRESSION OF STEPS, AND FAMILIARITY WITH THE TOTALITY OF THE FOLLOWING SECTION WILL AVOID POSSIBLE DAMAGE TO THE EQUIPMENT CAUSED BY INCORRECT ADJUSTMENTS.

To summarize the procedure that is followed in using the FC-700 antenna coupler to match a feed-line to the transmitter, the following process takes place:

- 1) The proper inductance is chosen using the BAND selector.
- 2) The LOAD and TUNE controls are adjusted to secure a minimum SWR. These two controls should be adjusted one at a time, so as to avoid confusion as to the effect of any particular adjustment. A typical procedure to follow would be to apply power, adjust the TUNE control for minimum SWR, then adjust the LOAD direction either to the right or left.

Once the LOAD control has been changed, the TUNE control should again be adjusted for minimum SWR; if this procedure improves the SWR, it should be continued by further moving the LOAD control in the same direction, but if the initial change in the LOAD control worsens the SWR, move the LOAD control in the opposite direction. It will be clear to the operator when the LOAD control is being adjusted in the right direction.

Refer to Figure 1, where the approximate positions of the BAND, LOAD, and TUNE controls are shown for matching to a 50-ohm load. The internal dummy load is used to preset the controls for the operating frequency. The antenna may then be selected, with final tuning taking only a few seconds.

- (1) Set up the FT-77 or other transceiver for normal operation. Set the DUMMY/ANT switch to DUMMY to select the built-in dummy load. Reduce the drive control on the transceiver to the minimum, and place the transmitter in the "standby" condition for the moment.
- (2) Place the BAND, LOAD, and TUNE controls in the positions shown in Figure 1 for the frequency nearest that at which the antenna is to be matched. Set the function switches to the FWD, SWR, and 150W positions. Set the SWR SET knob to the 12 o'clock position.
- (3) Make preliminary matching adjustments with as little transmitter power as possible. Place the FT-77 in the "transmit" condition (CW and press PTT), and slowly advance the drive until deflection of the meter needle on the FC-700 is observed. Adjust the SWR SET control to align the meter needle with the SET marking on the meter scale. Now switch the FWD/REV switch to REV for accurate reading of the SWR.
- (4) Adjust the TUNE control for minimum SWR. If necessary, adjust the SWR SET control and/or transmitter drive to ensure proper calibration (be certain to check the SWR meter sensitivity with the FWD/REV switch in the FWD position, then switch back to REV).

Once the "dip" has been found using the TUNE control, move the LOAD control a small amount in either direction, left or right. Adjust the TUNE control for a "dip" again, and if the SWR is lowered, move the LOAD control slightly more in the same direction as before. Again "dip" the TUNE control, and continue this procedure until no further improvement is noted. If the initial direction of adjustment of the LOAD control makes the SWR higher, move the control an equal distance in the opposite direction from the starting point, and "dip" the TUNE control. Remember to recheck the calibration of the SWR meter to avoid misleading readings.

- (5) Once the initial procedure has been followed to yield a near-perfect match, the transmitter may be adjusted for full power, and the FC-700 LOAD and TUNE controls may be adjusted to yield zero deflection of the SWR meter. When the SWR meter is not calibrated with the SWR SET control, it will not accurately read the SWR, but it will indicate minimum reflected power. Do not exceed the maximum key-down time stipulated for your transmitter.
- (6) Now set the DUMMY/ANT switch to ANT. Following the technique described above, tune your antenna system so as to secure minimum SWR with the antenna. Always begin tuning at low power, to avoid possible damage to transceiver or coupler components from unknown impedances.

BAND	FREQ	TUNE	LOAD
3.5	3.5 MHz	4.5	7.0
	4.0 MHz	5.5	7.5
7	7.0 MHz	6.0	7.5
	7.5 MHz	6.0	8.0
10	10.0 MHz	6.5	8.0
	10.5 MHz	7.0	8.5
14	14.0 MHz	6.5	8.5
	14.5 MHz	7.0	8.5
18	18.0 MHz	7.5	9.0
	18.5 MHz	7.5	9.0
21	21.0 MHz	7.5	9.0
	21.5 MHz	8.0	9.0
24.5	24.5 MHz	7.0	9.0
	25.0 MHz	7.0	9.0
28	28.0 MHz	7.0	8.5
	29.7 MHz	7.0	9.0

Figure 1

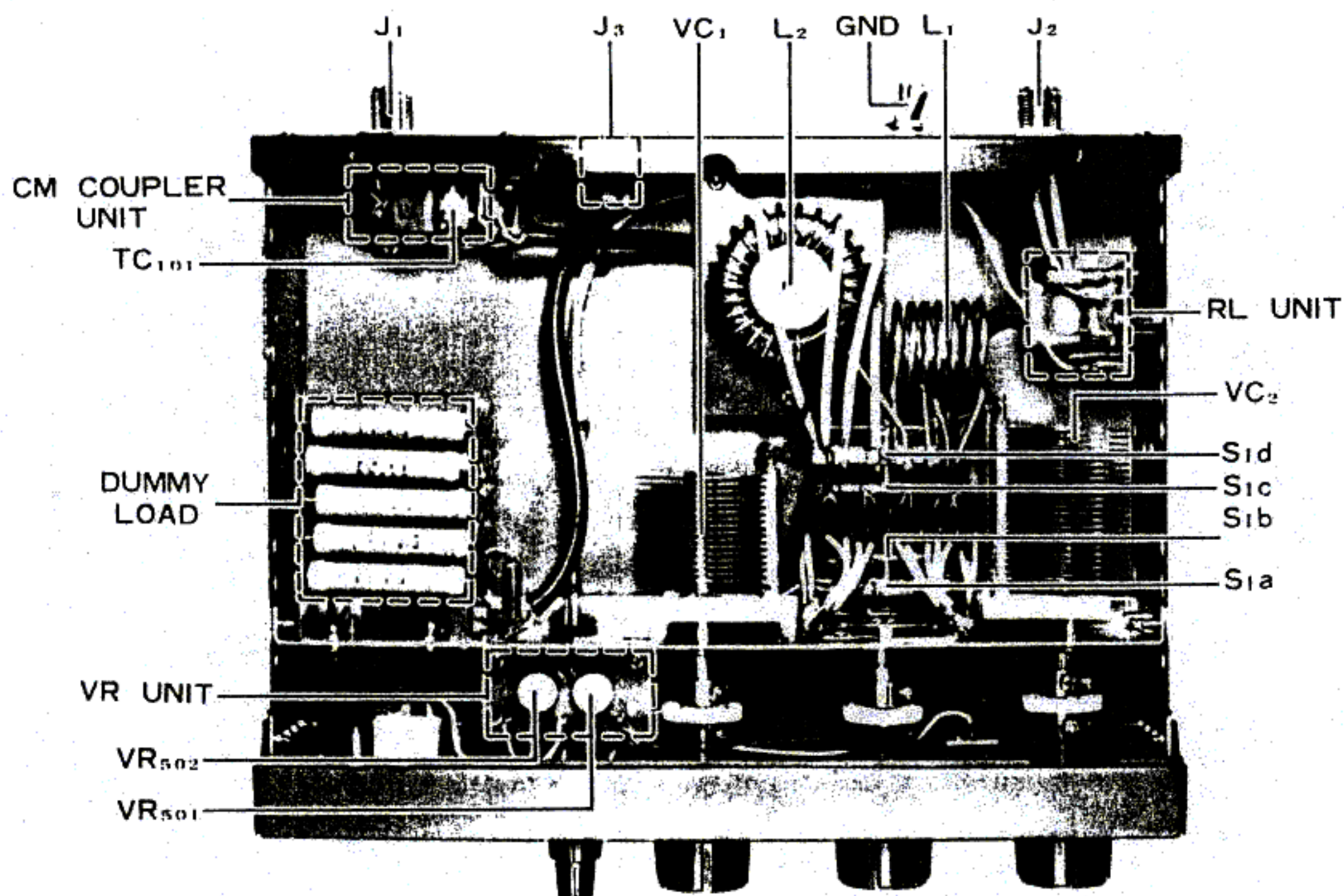

Top View

NOTES ON ANTENNA MATCHING

- (1) It is very important that the maximum time limits during tune-up conditions for the transmitter are not exceeded when the transmitter is being used at full power.
- (2) Any matching performed by the FC-700 in the shack will have no effect on the losses due to SWR on the coaxial line between the FC-700 coupler and the antenna. The operator should consult one of the popular antenna handbooks to determine whether or not matching between the coaxial line and the antenna must be performed at the antenna. For example, a 100-foot length of RG8A/U coax typically has a loss (with 1:1 SWR between it and antenna) of less than 1 dB at 21 MHz. If this line is operated with a 3:1 SWR due to a low or high antenna impedance, the loss due to SWR will increase roughly 0.5 dB, an imperceptible degradation as compared to the 1:1 condition. In this case, attempts to reduce the 3:1 SWR at the antenna end would serve no useful

purpose as far as reducing losses in the coax, through matching with the FC-700 would improve the impedance presented to the transmitter output circuitry. However, if a 500-foot length of the above coax were used instead of only 100 feet, somewhat more than 1 dB of loss would occur in the coax due to the 3:1 SWR, possibly justifying further matching attempts at the antenna.

- (3) When using a transceiver such as the FT-77 which has protection for the output transistors against high SWR, it can be seen that the matching action of the FC-700 will ensure that a 50-ohm load is presented to the output circuitry, thus ensuring full transmitter power.
- (4) It may be useful for the operator to record in a notebook the proper TUNE and LOAD positions for a particular antenna for quick reference. Alternatively, appropriate labels may be fabricated and applied to the FC-700 front panel showing the proper positions of the TUNE and LOAD controls for a particular frequency.

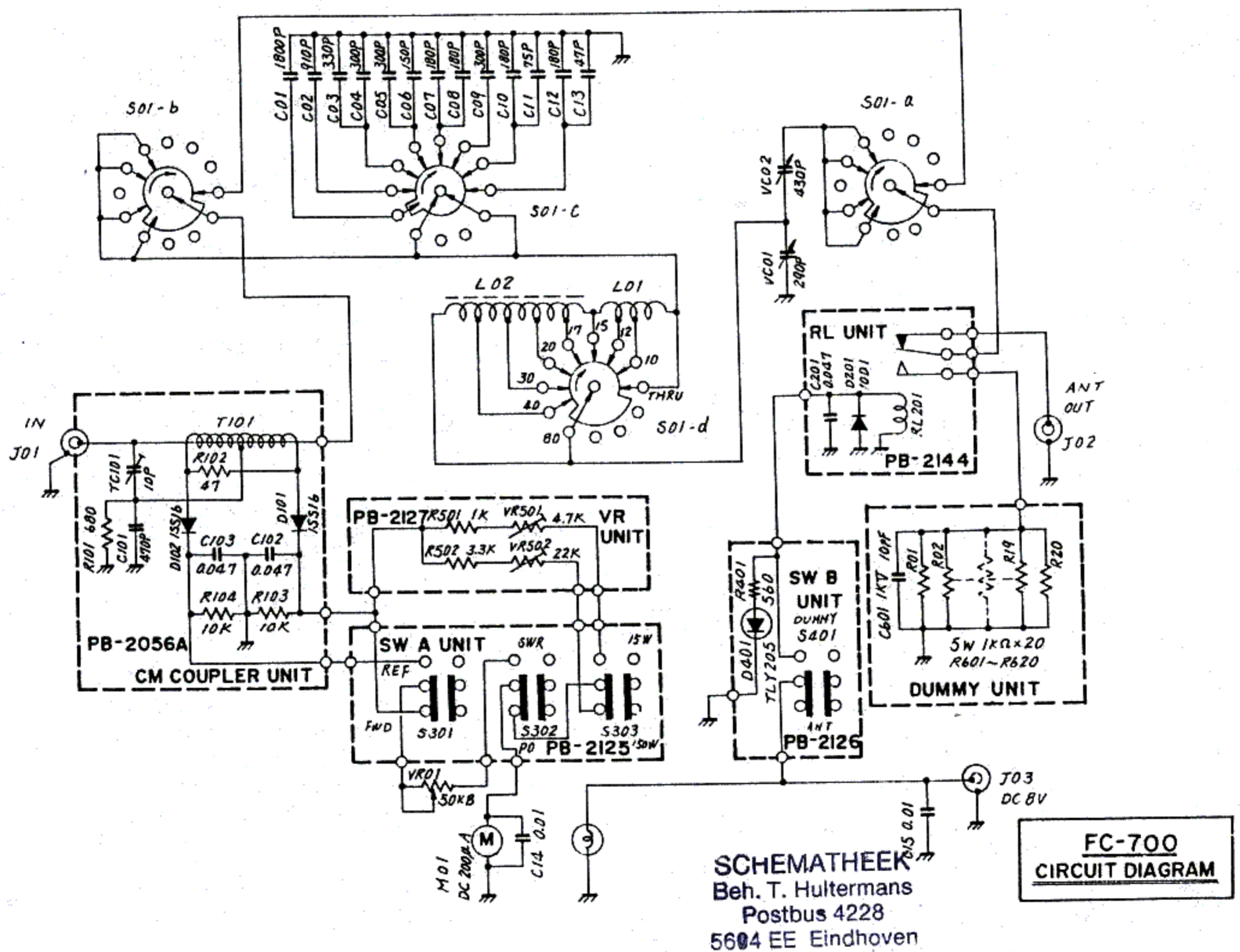

PARTS LIST

MAIN CHASSIS				RELAY UNIT		
Symbol No.	Part No.	Description		Symbol No.	Part No.	Description
		POTENTIOMETER			C0021240	P.C.B with Components
					F0002124	Printed Circuit Board
VR01	J6080070	VM10A949C-50kΩB				
						DIODE
				D201	G2090001	10D1
		VARIABLE CAPACITOR				CAPACITOR
VC01	K90000029	YB-290, 290pF				
VC02	K90000028	YB-430, 430pF		C201	K13170473	Ceramic disk
						RELAY
M01	M0290020	AP-80	DC 200μA	RL201	M1190025	MR-31
		SWITCH				
S01	N0190069	SRS-4.49			Q5000011	Wrapping terminal C
SWITCH A UNIT						
		RECEPTACLE		Symbol No.	Part No.	Description
J01,02	P1090028	M-BR-06D			C0021250	P.C.B with Components
J03	P0090093	X-G9242			F0002125	Printed Circuit Board
		INDUCTOR				SWITCH
L01	L0020799B			S301	N4090034	SUT31A
L02	L0020800B					
SWITCH B UNIT						
		CAPACITOR		Symbol No.	Part No.	Description
C13	K30309005	Dipped mica	1kWV 47pF		C0021260	P.C.B with Components
C11	K30309001	" "	" 75pF		F0002126A	Printed Circuit Board
C06	K30309004	" "	" 150pF			
C07,08,10,12	K30309006	" "	" 180pF			DIODE
C04,05,09	K30309011	" "	" 300pF	D401	G2090134	LED TLY-205
C03	K30309010	" "	" 330pF			
C02	K30309009	" "	" 910pF			SWITCH
C01	K30309008	" "	" 1800pF	S401	N4090035	SUT12A
C14,15	K13170103	Ceramic disk	50WV 0.01μF			
						RESISTOR
				R401	J00245561	Carbon film 1/4W VJ 560Ω
CM COUPLER UNIT				VR UNIT		
Symbol No.	Part No.	Description		Symbol No.	Part No.	Description
	C0020560	P.C.B with Components			C0021270	P.C.B with Components
	F0002056A	Printed Circuit Board			F0002127	Printed Circuit Board
		DIODE				POTENTIOMETER
D101,102	G2090038	ISS16		VR501	J51723472	SR-19R 4.7kΩB
				VR502	J51723223	" 22kΩB
		RESISTOR				
R102	J01245470	Carbon film	1/4W TJ 47Ω			RESISTOR
R101	J00245681	" "	" VJ 680Ω			
R103,104	J00245103	" "	" " 10kΩ	R501	J00245102	Carbon film 1/4W VJ 1kΩ
				R502	J00245332	" " " " 3.3kΩ
		CAPACITOR				
C101	K30176471	Dipped mica	50WV 470pF			
C102	K13170473	Ceramic disk	" 0.047μF			
DUMMY LOAD UNIT						
				Symbol No.	Part No.	Description
						RESISTOR
				R601-620	J20375102	RSF-5BJ 5W 1kΩ
		TRIMMER CAPACITOR				CAPACITOR
VC101	K91000019	ECV-1ZW 10x40, 10pF				
		INDUCTOR		C601	K31309001	Mica 1kWV 10pF
T101	L0020301A					
ACCESSORIES						
				Symbol No.	Part No.	Description
					T9101220	Connection cable
					R3054370	Plastic Foot
					Q5000011	Wrapping terminal C
					U00406001	Screw M4x6