

MAINTENANCE SERVICE MANUAL FT-707



YAESU MUSEN CO., LTD.

C.P.O. BOX 1500
TOKYO, JAPAN

YAESU ELECTRONICS CORP.

P.O. BOX 49
PARAMOUNT, CALIFORNIA, 90723

INDEX

| | Page |
|--|------|
| FOREWORD | i |
| SECTION 1 – GENERAL | |
| GENERAL DESCRIPTION | 1-1 |
| SPECIFICATIONS | 1-2 |
| SEMICONDUCTORS | 1-3 |
| FRONT PANEL CONTROLS AND SWITCHES | 1-4 |
| REAR PANEL CONNECTIONS | 1-6 |
| MICROPHONE CONNECTIONS | 1-7 |
| INSTALLATION | 1-8 |
| POWER SUPPLY FP-707 | 1-11 |
| INTERCONNECTIONS | 1-12 |
| RELAY BOX FRB-707 | 1-13 |
| ANTENNA TUNER FC-707 | 1-14 |
| OPERATION | 1-15 |
| SECTION 2 – TECHNICAL NOTES | |
| SIGNAL TRACING IN THE FT-707 | 2-1 |
| RX FREQUENCY RELATIONSHIPS | 2-6 |
| CRYSTAL DATA | 2-6 |
| TX CONTROL LINE CIRCUIT | 2-7 |
| CIRCUIT DESCRIPTION | 2-8 |
| SECTION 3 – SERVICING | |
| OUTER COVER REMOVAL | 3-1 |
| FRONT PANEL REMOVAL | 3-2 |
| REAR PANEL REMOVAL | 3-4 |
| 100W PA UNIT REMOVAL | 3-5 |
| MAIN CHASSIS EXPLODED VIEW | 3-6 |
| BOARD LAYOUT | 3-7 |
| SOLDERING AND DESOLDERING TECHNIQUE | 3-9 |
| CIRCUIT TRACING REPAIR | 3-10 |
| INSTALLATION: OPTIONS | |
| CW FILTER INSTALLATION | 3-12 |
| FIX (CRYSTAL CONTROLLED) OPERATION | 3-13 |
| MODIFICATIONS | |
| S/N IMPROVEMENT ON 80M BAND | 3-14 |
| MODIFICATION TO ELIMINATE “CLICKING” NOISE ON CW ... | 3-14 |
| TX IMD DISTORTION IMPROVEMENT | 3-15 |
| MARKER MODIFICATION | 3-16 |
| PREMIX MODIFICATION | 3-16 |
| RECEIVER INPUT CIRCUIT MODIFICATION | 3-17 |
| WARC TX MODIFICATION | 3-18 |
| FREQUENCY COUNTER PRESET CHANGE | 3-19 |

| | |
|---|------|
| MAINTENANCE AND ALIGNMENT | 3-21 |
| FAULT IDENTIFICATION AND LOCALIZATION | 3-29 |
| TROUBLESHOOTING | 3-30 |
| RELAY CONNECTION INFORMATION | 3-36 |
| CIRCUIT BOARD LAYOUT AND TEST VOLTAGE | |
| RF UNIT (PB-2093A/PB-2201) | 3-37 |
| IF UNIT (PB-2094A) | 3-43 |
| AF UNIT (PB-2095A) | 3-46 |
| AVR UNIT (PB-2099A) | 3-49 |
| COUNTER/DISPLAY UNIT (PB-2086A-3540/PB-2098-3540) | 3-50 |
| VFO ASSEMBLY (PB-2097A) | 3-54 |
| 100W PA UNIT (PB-2013) | 3-58 |
| HPF/FAN MOTOR CONTROL UNIT (PB-2101) | 3-61 |
| LEVEL METER UNIT (PB-2100) | 3-62 |
| SW UNIT (PB-2102) | 3-63 |
| VR UNIT (PB-2103A) | 3-63 |
| SWITCH ASSEMBLIES | 3-64 |
| POTENTIOMETER ASSEMBLIES | 3-65 |

SECTION 4 – REPAIR PARTS

| | |
|------------------------------------|-----|
| PARTS LIST AND ORDERING DATA | 4-1 |
| PARTS LIST | 4-5 |

FOREWORD

The purpose of this manual is to provide the reader with information critical to the operation and maintenance of the FT-707 transceiver. Technical details are geared for maximum comprehension by technician or owner, rather than the design engineer. To this end, the descriptions have been kept brief while photographs and drawings are utilized liberally.

Use of this manual is entirely at the owner's risk. While we believe the material presented herein to be correct and factual, we assume no liability for damage which may occur when this manual is used as a reference.

The FT-707 has had an enviable service record, and we trust that you will seldom have recourse to this manual. Should reference be necessary, though, we hope and trust that the information presented will be sufficient for your service needs.

Yaesu Musen Company, Ltd
Tokyo, Japan

SECTION 1 — GENERAL

| | |
|---|------|
| GENERAL DESCRIPTION | 1-1 |
| SPECIFICATIONS | 1-2 |
| SEMICONDUCTORS | 1-3 |
| FRONT PANEL CONTROLS AND SWITCHES | 1-4 |
| REAR PANEL CONNECTIONS | 1-6 |
| MICROPHONE CONNECTIONS | 1-7 |
| INSTALLATION | 1-8 |
| POWER SUPPLY FP-707 | 1-11 |
| INTERCONNECTIONS | 1-12 |
| RELAY BOX FRB-707 | 1-13 |
| ANTENNA TUNER FC-707 | 1-14 |
| OPERATION | 1-15 |

YAESU

ALL SOLID STATE HF SSB TRANSCEIVER

FT-707

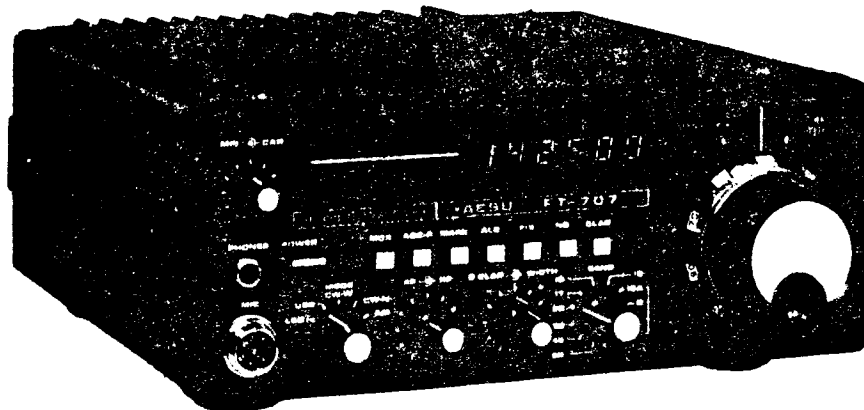

GENERAL DESCRIPTION

The FT-707 is an all solid state transceiver for the HF amateur bands. Featuring coverage of 80 through 10 meters, the FT-707 is designed for operation on SSB, CW and AM. Nominal power output is 100 watts on SSB and CW, and 50 watts on AM.

The extremely compact size of the FT-707 makes this model particularly well suited for mobile or vacation use. However, the advanced design techniques used in the FT-707 make it competitive with "top of the line" equipment of other manufacturers.

The receiver section includes a new and sophisticated front end, using a Schottky barrier diode ring module and carefully designed gain distribution, for excellent performance in the presence of strong signals. A very-low-noise pre-mix local oscillator circuit is used, which further contributes to optimum receiver performance. Also included in the receiver is Yaesu's famous variable IF bandwidth, using two 8 pole IF filters, allowing continuously variable adjustment of the IF bandwidth, from 300 Hz to 2.4 kHz. Six pole filters of 600 Hz and 350 Hz bandwidth (-6 dB) are available for contest and DX operators, with selection of the SSB filter or CW filter available on the CW mode.

The transmitter side features two rugged bipolar transistors with multiple protection in the final amplifier stage, with bandswitched low pass filter networks providing excellent spectral purity.

Digital plus analog display of the operating frequency is provided. The front panel meter consists of a string of bright discrete LEDs, for easy monitoring of the received signal strength, relative power output, and the transmit ALC level.

Available options for the FT-707 include the FP-707 AC Power Supply, which provides the 13.5 volts DC required by the FT-707. The FP-707 provides outstanding regulation, for many years of trouble-free operation. Also available is the exciting FV-707DM external VFO, which provides twelve memory channels using a sophisticated synthesizer which allows scanning in 10 Hz steps and offset from memory channels. And for matching your antenna system to the 50 ohm impedance requirement of the FT-707, choose the FC-707 Antenna Coupler. All of the above accessories, plus a special mobile mounting bracket, are available from your Yaesu dealer.

SPECIFICATIONS

GENERAL

Frequency coverage:

| | |
|------|---------------|
| 80 m | 3.5–4.0 MHz |
| 40 m | 7.0–7.5 MHz |
| 30 m | 10.0–10.5 MHz |
| 20 m | 14.0–14.5 MHz |
| 17 m | 18.0–18.5 MHz |
| 15 m | 21.0–21.5 MHz |
| 12 m | 24.5–25.0 MHz |
| 10 m | 28.0–29.9 MHz |

Modes of operation:

LSB, USB, CW, and AM

Power requirements:

13.5 volts DC, negative ground

Current consumption:

DC 1.5 amps receive

DC 20 amps transmit

Case size:

93 (H) x 240 (W) x 295 (D) mm incl. heat sink

Weight:

Approx. 6.5 kg

TRANSMITTER

Power input:

| | |
|--------|--------------|
| SSB/CW | 240 watts DC |
| AM | 80 watts DC |

Carrier suppression:

Better than 40 dB

Unwanted sideband suppression:

Better than 50 dB at 14 MHz, 1 kHz mod.

Spurious emissions:

At least 50 dB down

Frequency response:

350–2700 Hz (–6 dB)

Third order distortion products:

At least 31 dB down

Frequency stability:

Less than 300 Hz drift over 30 minutes at
10 minute warmup; less than 100 Hz d
after 30 minute warmup

RECEIVER

Sensitivity:

SSB/CW 0.25 μ V for 10 dB S/N

AM 1.0 μ V for 10 dB S/N

Selectivity:

SSB 2.4 kHz (–6 dB); 4.0 kHz (–60 dB)

CW* 0.6 kHz (–6 dB), 1.2 kHz (–60 dB)

CW** 350 Hz (–6 dB), 1.2 kHz (–60 dB)

AM 3.6 kHz (–6 dB), 6.8 kHz (–60 dB)

Image rejection:

60 dB (80–12 m)

50 dB (10 m)

Audio output impedance..

4–16 ohms

Audio output:

3 watts (*a*) 4 ohms (*a*) 10% THD

Variable bandwidth control:

Continuous from 300 Hz to 2.4 kHz (SSB/
modes only)

Modulation type:

(SSB) Balanced modulator

(AM) Amplitude modulation of a low pc
stage

Antenna output impedance:

50 ohms

Microphone impedance:

500–600 ohms (low impedance)

* with optional 600 Hz CW filter

** with optional 350 Hz CW filter

SEMICONDUCTORS

Transistors:

| | |
|-------------|----|
| 2SA496Y | 1 |
| 2SA733A-P | 2 |
| 2SA733A-Q | 4 |
| 2SA952L | 13 |
| 2SC380TM-Y | 12 |
| 2SC535A | 1 |
| 2SC732TM-GR | 1 |
| 2SC1583G | 2 |
| 2SC1589 | 2 |
| 2SC1674L | 1 |
| 2SC1815GR | 3 |
| 2SC1815Y | 29 |
| 2SC1923R | 2 |
| 2SC1959Y | 3 |
| 2SC2290 | 2 |
| 2SC2395 | 2 |
| 2SC2407 | 2 |
| 2SD235Y | 1 |
| 2SD592Q | 1 |
| 2SD880Y | 1 |
| 2N4427 | 1 |
| MPS-A13 | 1 |

Field Effect Transistors:

| | |
|------------|---|
| 2SK19TM-GR | 5 |
| 2SK30A-Y | 1 |
| 3SK73GR | 7 |
| J310 | 1 |

Integrated Circuits (IC):

| | |
|---------------|---|
| SN76514N | 1 |
| μ PC2002V | 1 |
| μ PA54H | 1 |
| AN6552 | 1 |
| F4024 | 1 |
| MSM9520RS | 1 |
| TA7612AP | 1 |
| 78L08 | 3 |
| μ PC14305 | 1 |
| μ PC14308 | 1 |
| ND487C2-3R | 1 |

Germanium Diode:

| | |
|--------|----|
| 1N60 | 26 |
| 1S1007 | 14 |

Silicon Diodes:

| | |
|--------|----|
| 10D1 | 14 |
| 10D10 | 4 |
| 1S1555 | 66 |
| 1SS53 | 37 |

Schottky Barrier Diode:

| | |
|-------|---|
| 1SS16 | 6 |
|-------|---|

Zener Diode:

| | |
|--------|---|
| YZ-033 | 1 |
|--------|---|

Varactor Diodes:

| | |
|--------|---|
| 1S2209 | 1 |
| 1S2236 | 1 |
| FC63 | 1 |

Light Emitting Diodes:

| | |
|------------|---|
| GD4-203SRD | 1 |
| TLG205 | 5 |
| TLR205 | 2 |
| TLY205 | 3 |

LED Display:

| | |
|-----------|---|
| 5082-7623 | 6 |
|-----------|---|

Specifications subject to change without notice.

ACCESSORIES

The following accessories are included with your FT-707.

| | |
|---------------|---|
| DC Power Cord | 1 |
| DC Fuse (20A) | 1 |

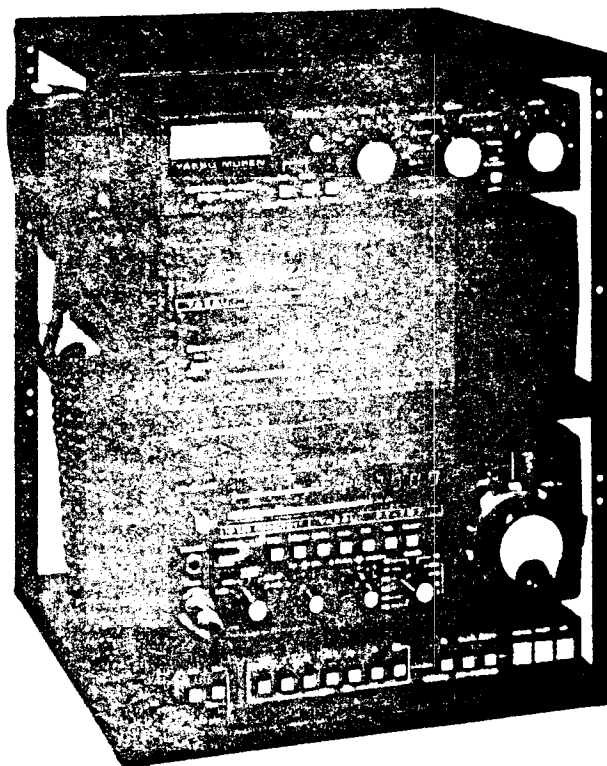

FC-707/FP-707/FT-707/FV-707DM/YM-35

FRONT PANEL CONTROLS AND SWITCHES

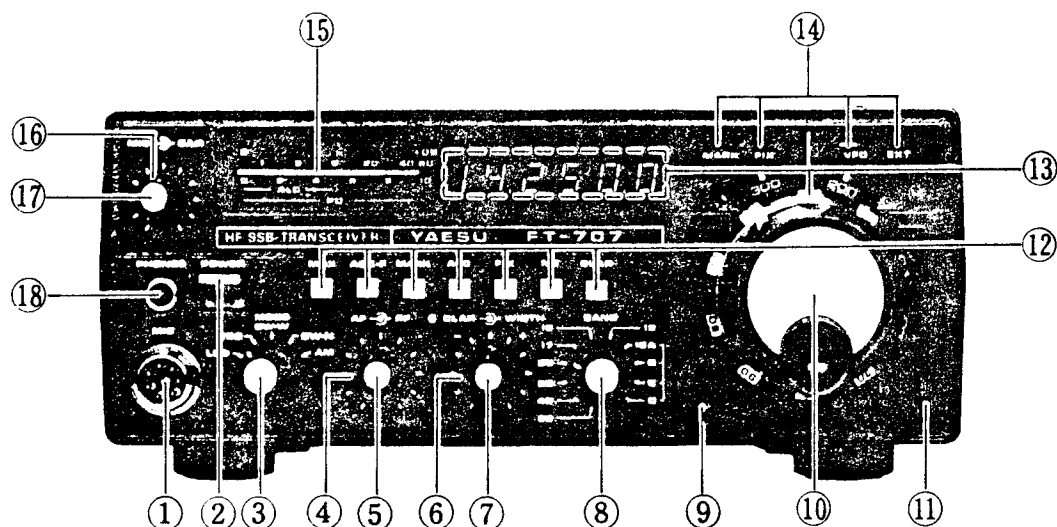
**(1) MIC**

The microphone jack accepts the microphone input line, push to talk (PTT) control, and scanner control lines (scanner requires optional FV-707DM).

(2) POWER

This is the main power on/off switch for the transceiver.

(3) MODE

This switch selects the desired mode: LSB, USB, CW-W (using SSB filters), CW-N (using optional 600 Hz or 350 Hz filter), or AM.

(4) RF GAIN

This control varies the gain of the receiver RF and IF stages. Clockwise rotation increases the gain level.

(5) AF GAIN

This control varies the gain of the audio amplifier stage. Clockwise rotation increases the AF volume level.

(6) WIDTH

The WIDTH control varies the IF passband from 2.4 kHz down to approximately 300 Hz (-6 dB).

(7) CLAR

This control allows offset from the VFO frequency of approximately ± 3 kHz on receive, when the front panel CLAR switch is pushed.

(8) BAND

This switch selects the desired band.

(9) VOX GAIN

This control varies the sensitivity of the VOX (voice operated T/R control) system.

(10) MAIN TUNING KNOB

This knob drives the main tuning variable capacitor, for control of the operating frequency.

(11) DELAY

This control provides adjustment of the VOX relay hang time. It may be set for your individual requirements for CW or SSB operation.

(12) SELECT switches

MOX This switch selects manual activation of the transmitter. Push the switch once to close the PTT circuit, and again to allow receiver recovery.

AGC F Push this switch to select fast recovery time for the receiver AGC (Automatic Gain Control) circuitry. When this button is not pushed, slow AGC recovery will be selected.

MARK Push this button to activate the crystal calibrator (marker) circuit. The calibrator signal will be heard every 25 kHz.

ALC This switch checks the ALC level by the LED meter. When this button is not

pushed, the LED meter indicates TX relative power output (PO).

FIX Push this switch to operate on a fixed channel.

NB This button activates the noise blanker circuit.

CLAR Push this button to activate the receiver offset tuning (clarifier) feature.

(13) DIAL

The main tuning dial is calibrated every 50 kHz, with dial skirt markings every 1 kHz, for precise frequency determination.

(14) INDICATOR LEDs

These LED indicators provide visual reminders of calibrator, fixed channel (using an optional crystal), VFO, or external VFO operation.

(15) LEVEL METER

A string of colored LEDs provides visual indication of the received signal strength, relative power output, and the transmitter ALC level.

(16) CAR

The carrier control adjusts the CW or AM carrier level.

(17) MIC GAIN

This control varies the gain of the microphone amplifier stage during SSB or AM operation.

(18) PHONES

This is a standard phone plug for connection of your station headphones. The impedance is 8 ohms.

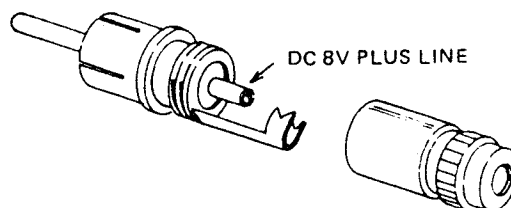
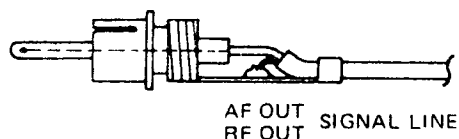

Pin plug

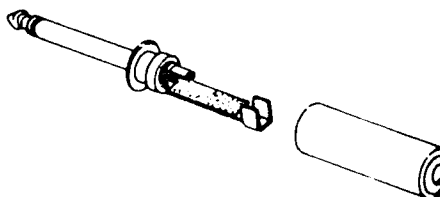

Headphone and external speaker connections

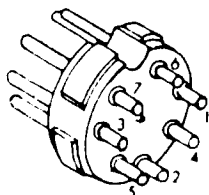

- | | |
|--------|-----------------|
| PIN No | |
| 1 | FAST CONT (MIC) |
| 2 | DOWN CONT (MIC) |
| 3 | E |
| 4 | PTT |
| 5 | UP CONT (MIC) |
| 6 | TX 13.5V |
| 7 | PATCH MIC IN |

ACC Plug

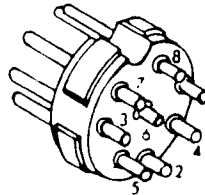

- | | |
|--------|------------|
| PIN No | |
| 1 | E |
| 2 | TX 8V |
| 3 | E |
| 4 | 8V |
| 5 | VFO FIX 8V |
| 6 | 13.5V |
| 7 | EXT VFO IN |
| 8 | MEMORY OUT |

EXT VFO Plug

REAR PANEL CONNECTIONS

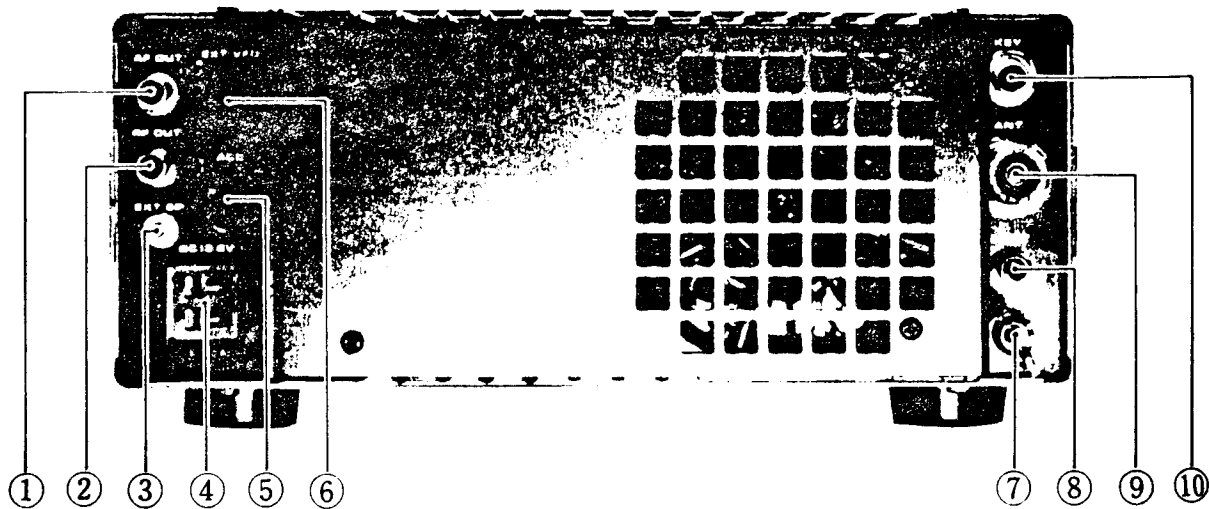

(1) AF OUT

This is an audio output jack which provides approximately 200 mV of audio output (before the AF GAIN control) for use with a tape recorder, etc.

(2) RF OUT

This is a low level signal frequency output jack for use with a transverter. The output is at 50 ohms impedance, at a level of 220 mV.

(3) EXT SP

This is a jack for connection to your station's external speaker. The FT-707 internal speaker will be cut off when a plug is inserted into this jack. The audio output impedance is 8 ohms.

(4) DC 13.5V

Connect this jack only to a DC supply of 13.5 volts, negative ground. Never connect AC power directly to this jack.

(5) ACC

The accessory plug accepts microphone input and PTT control lines, while providing connections to the output scanning control lines and the transmitter TX 13.5V line.

(6) EXT VFO

This jack provides connections to the FV-707DM External VFO.

(7) GND

Connect a good earth ground at this point.

(8) DC 8V

This jack provides an output of 8 volts DC for use with the FC-707 Antenna Coupler. The 8 volt line provides power for the FC-707 panel lamps.

(9) ANT

This is a standard UHF connector for connection to the station antenna system.

(10) KEY

Connect your CW key at this jack.

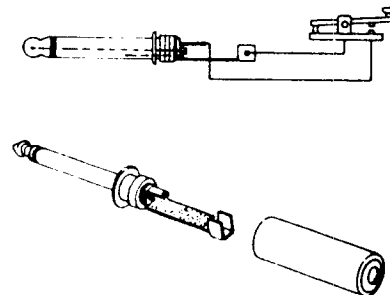

Key plug connections

MICROPHONE CONNECTIONS

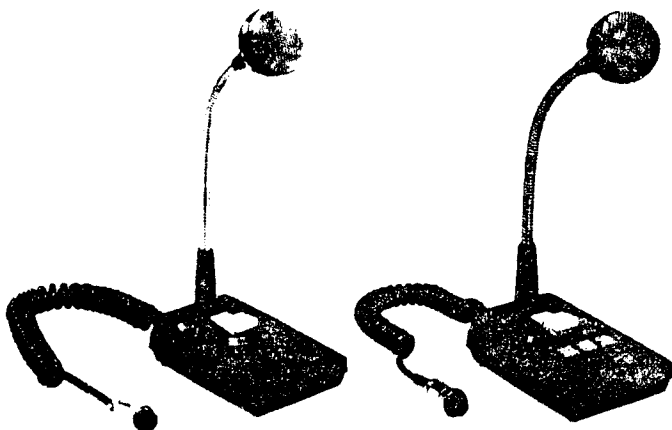

YM-34

YM-38

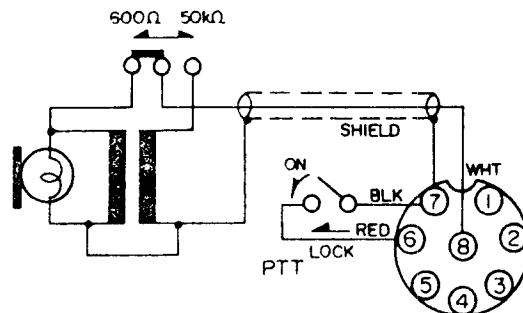

YM-34 MICROPHONE CONNECTIONS



YM-35

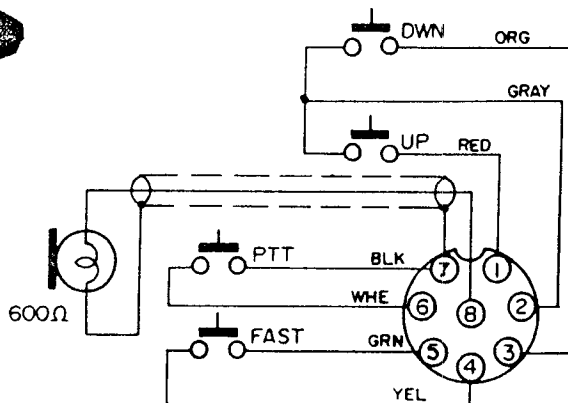

YM-35/YM-38 MICROPHONE CONNECTIONS



YM-36

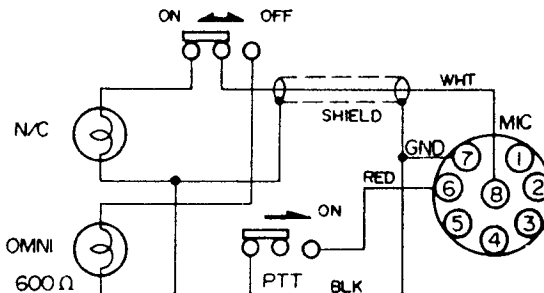

YM-36 MICROPHONE CONNECTIONS



YM-37

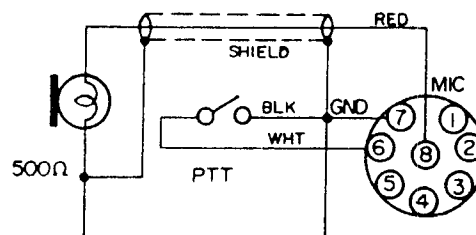

YM-37 MICROPHONE CONNECTIONS

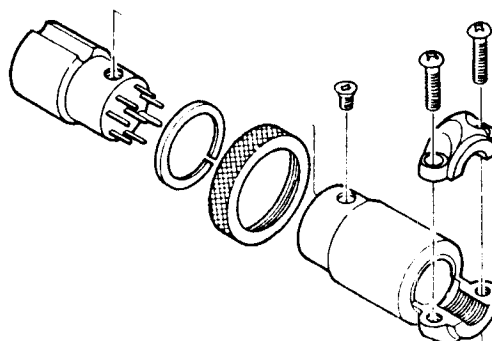

INSTALLATION

ANTENNA CONSIDERATIONS

The FT-707 is designed for use into a 50 ohm resistive load. While minor deviations from the 50 ohm figure are of no consequence, the automatic final protection (AFP) circuitry will reduce the power output if high SWR conditions are encountered.

However, your FT-707 AFP circuitry and final amplifier components are tolerant of the minor SWR conditions present in many amateur installations. At an SWR of 3:1, for example, 50% of the full rated output power will be obtained.

The Yaesu RSL series of mobile antennas is available from your Yaesu dealer, for mobile installations.

GROUND CONNECTIONS

This transceiver should be connected to a good earth ground for best performance and safety. Use a heavy, braided wire, less than 10 feet line, for connection to your station ground buss. The ground line should be connected to the transceiver rear panel GND terminal.

POWER REQUIREMENTS

This transceiver requires a power source of 13.5 volts DC, negative ground, at 20 amps on voice peaks. It is not possible to use this transceiver on 24 volts DC, or on AC voltages of any kind.

WARNING

Use of this equipment from improper DC voltages, or from AC voltages of any kind, will void the warranty on this equipment.

Please refer to the following sections for details on making power connections for mobile or base station installations.

FUSE REQUIREMENTS

A 20 amp DC fuse is located in the DC cable for this equipment. When changing fuses, be absolutely certain to use a fuse of the proper rating.

WARNING

Our warranty does not cover damage caused by use of an improper fuse.

MOBILE INSTALLATION

The DC cable for mobile installations is included with your transceiver.

For under-dash mounting, a special mobile mounting bracket is available from your Yaesu dealer. This bracket, known as the MMB-2, allows installation of the FT-707 alone, or it may be adjusted to allow installation of the FT-707 and FV-707DM, or the FT-707 and FC-707 (the FC-707 and FV-707 may also be installed together, if desired).

The FT-707 should be mounted where there is adequate space around the heat sink to allow free circulation of air. Allow a space of about 20 cm behind and around the heat sink, and do not position the transceiver directly in the path of the heater ducts.

When making battery connections, it is absolutely essential that the proper polarity of the power cord be observed.

WARNING

Permanent damage will result if reversed-polarity supply voltage is applied to this transceiver. Our warranty does not cover damage caused by reversed power supply connections.

It is recommended that power connections be made directly to the battery instead of to the ignition switch. The battery provides considerable filtering against ignition noise, while connection to the ignition switch can place the FT-707 in a noise-producing circuit. The power lead must be kept as short as possible, and you should keep the lead away from ignition cables as much as possible.

When making battery connections, be certain to connect the RED power cable lead to the POSITIVE (+) battery terminal, and connect the BLACK lead to the NEGATIVE (-) terminal.

Before connecting the DC cable to the transceiver, check the battery voltage with the engine running fast enough to show a charge on the vehicle's ammeter. If the voltage exceeds 15 volts, the automobile voltage regulator should be adjusted, so as to limit the maximum voltage to less than 15 volts. As well, do not operate this transceiver from a power source of less than 12 volts. The transceiver should always be turned off when the car is started, to prevent transients in the automobile electrical system from damaging the transistor circuitry of the FT-707.

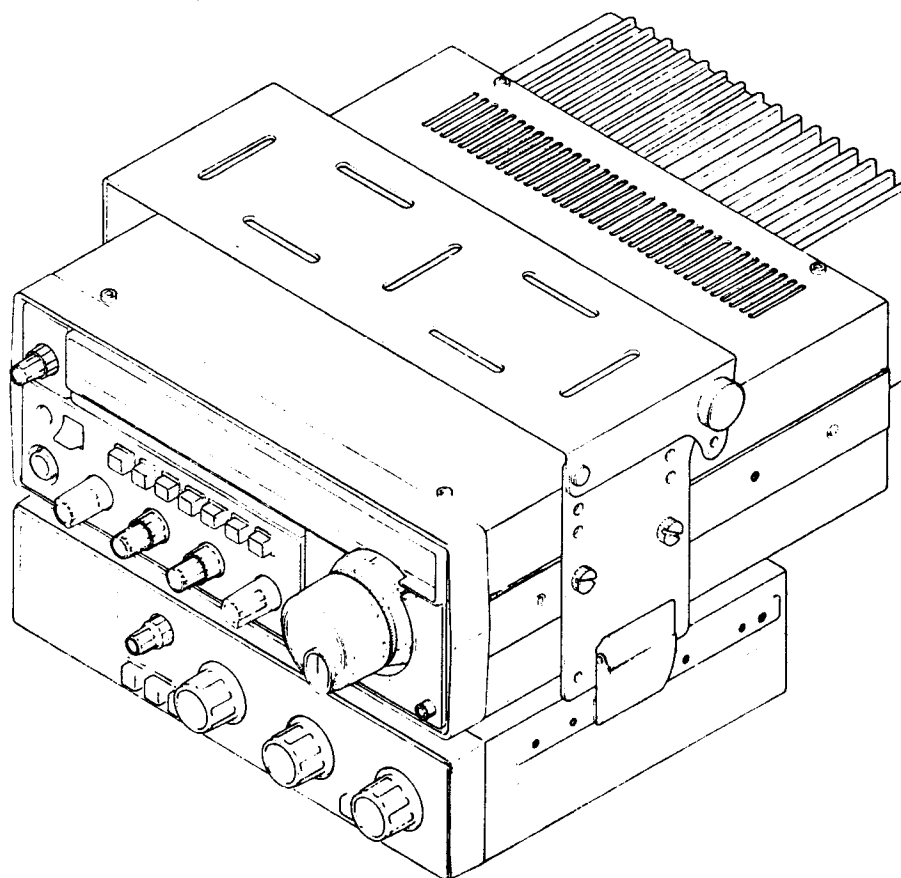

FT-707/FC-707/MMB-2

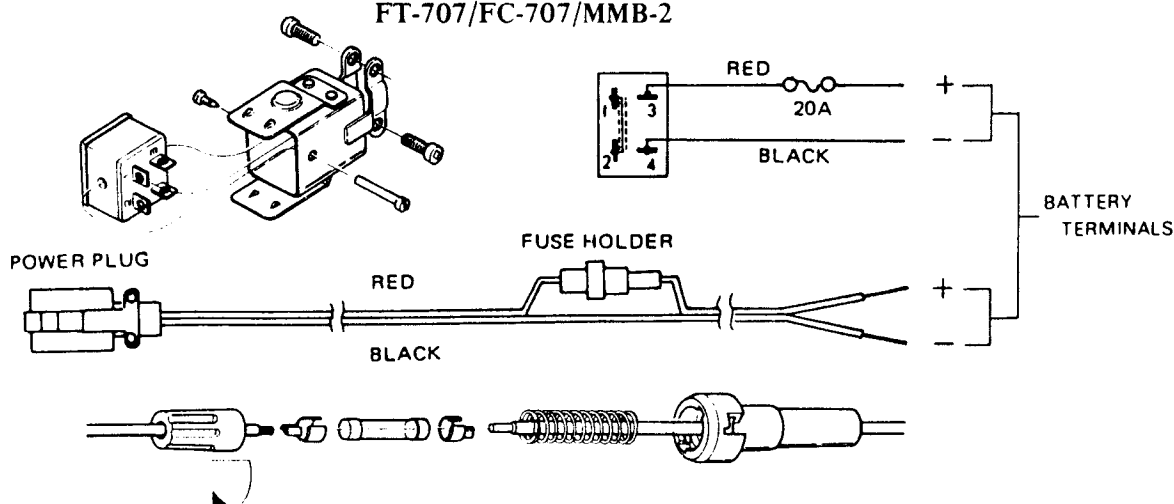

POWER CORD CONNECTIONS

GENERAL

BASE STATION INSTALLATION

The FP-707 AC Power Supply is expressly designed for the FT-707 transceiver, allowing operation from AC power sources of 100/110/117/200/220/234 volts, 50/60 Hz.

Before attempting operation of the FP-707 from AC mains, check to see that the voltage specification on the rear panel of the power supply matches your local supply voltage. This inspection must be made before applying power to this equipment.

WARNING

Operation of the FT-707 directly from AC mains, or operation of the FP-707 from improper supply voltages, or use of an improper fuse in either model, shall void the warranty.

Please refer to the power transformer primary connection chart for details of the proper connections inside the FT-707.

An AC fuse is located on the rear panel of the FP-707. For AC 100/110/117 volts, use only a 6 amp fuse. For 200/220/234 volts AC, use only a 3 amp fuse.

Once the power transformer and fuse inspections have been duly completed, connect the AC cable of the FP-707 to the wall outlet. Insert the DC plug from the FP-707 into the FT-707 DC 13.5V jack on the rear panel of the transceiver.

Connect a 50 ohm antenna or dummy load to the rear panel ANT jack.

Connect your station headphones, if used, to the front panel PHONES jack. Insertion of a plug into this jack automatically cuts off the internal speaker.

If you are using an external speaker, its plug may be connected to the rear panel SP jack. Insertion of a plug into this jack also cuts off the internal speaker. If headphones are used, insertion of the headphone plug into the front panel jack will cut off the external speaker, as well as the internal speaker.

If you are using a footswitch for PTT control, the lead from the footswitch may be connected to pin 6 of the rear panel ACC jack. Use pin 7 for the common connection.

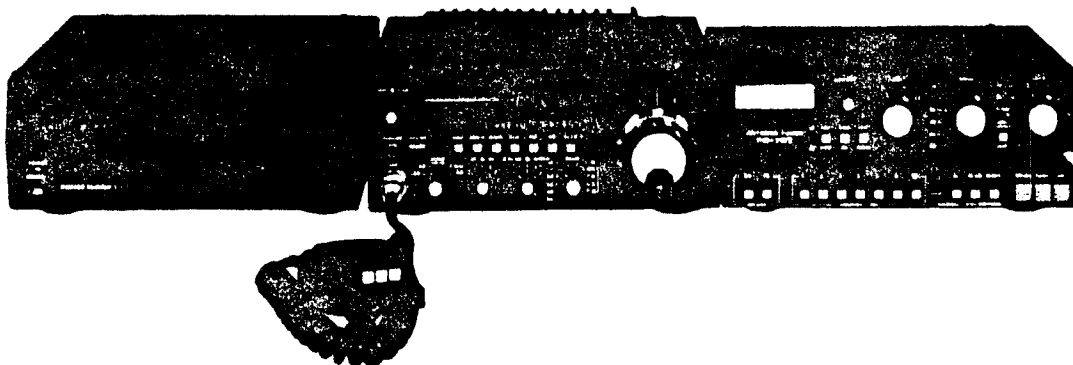

FP-707/FT-707/YM-35/ FC-707/FV-707DM

POWER SUPPLY FP-707

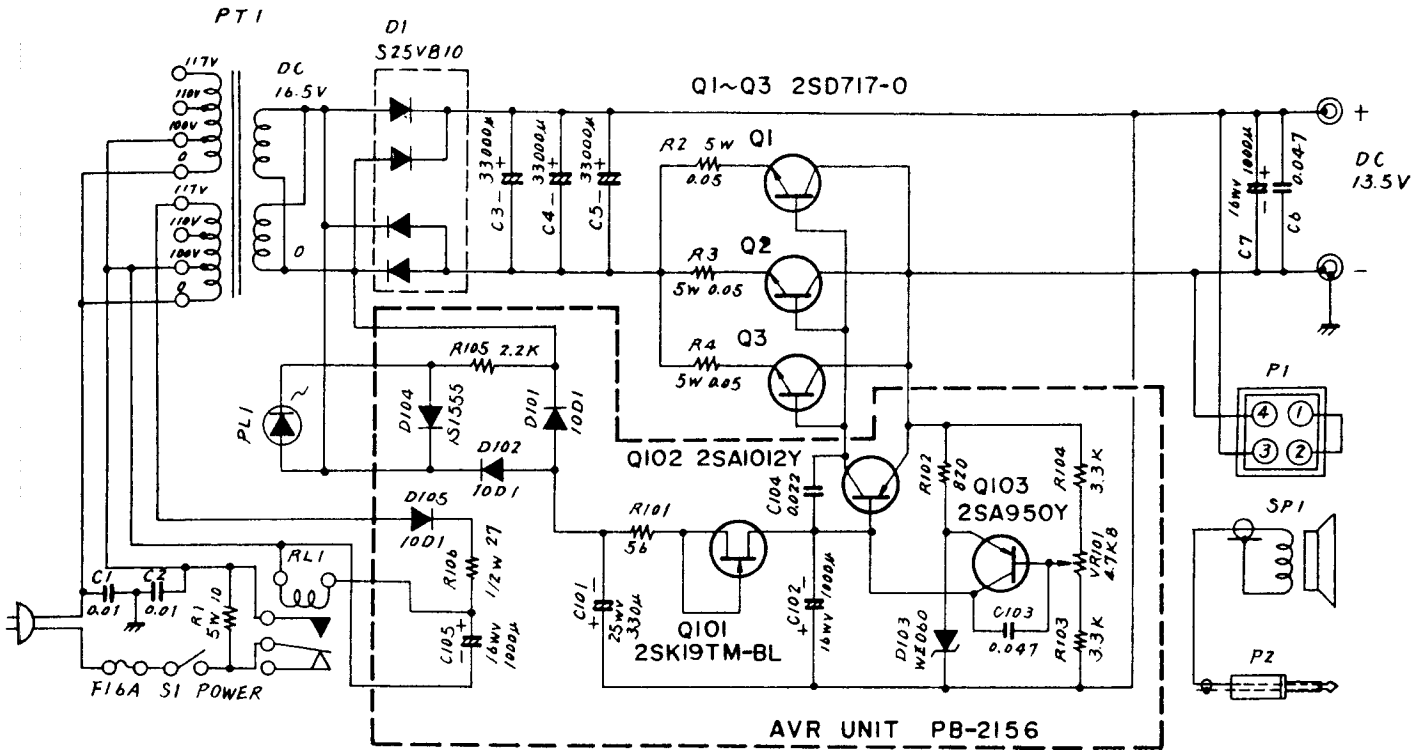

FP-707 CIRCUIT DIAGRAM

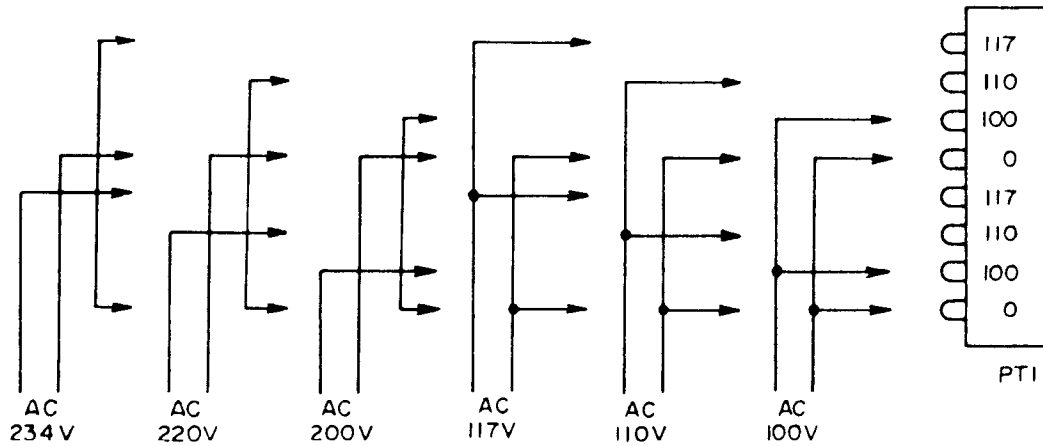

FP-707 POWER TRANSFORMER PRIMARY CONNECTIONS

INTERCONNECTIONS

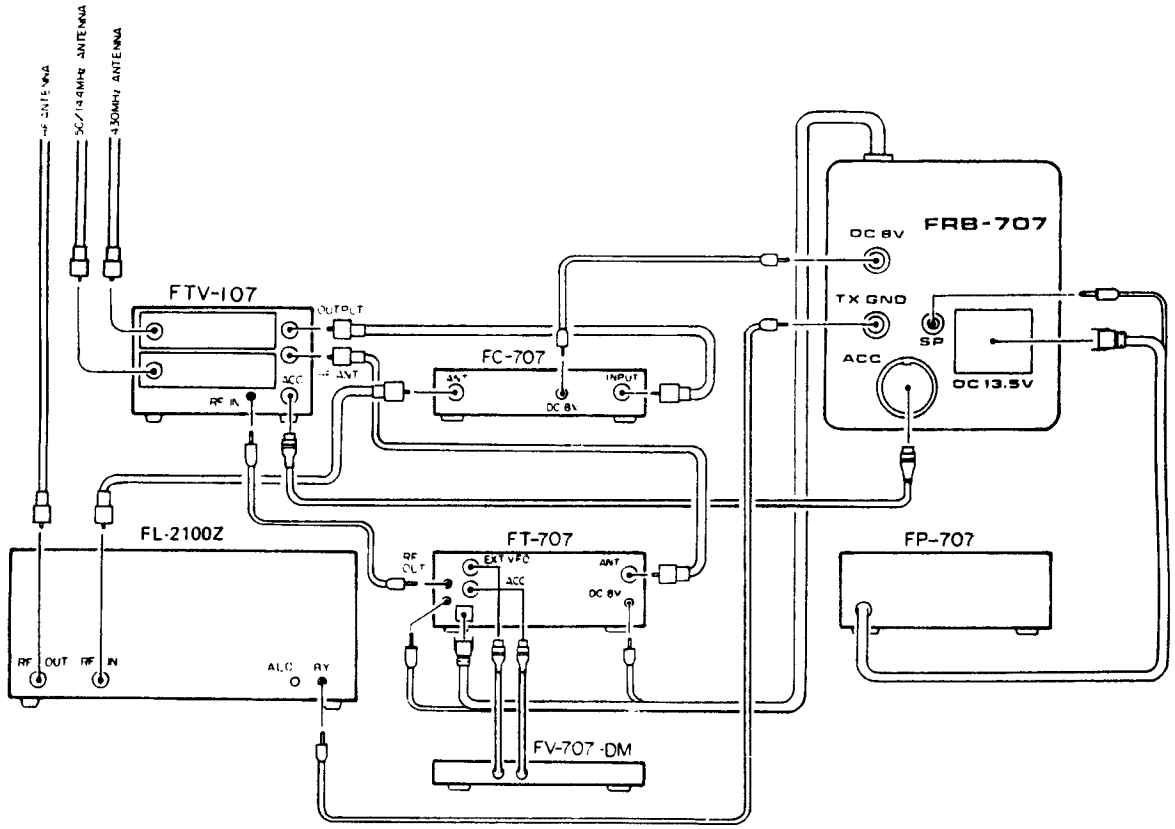
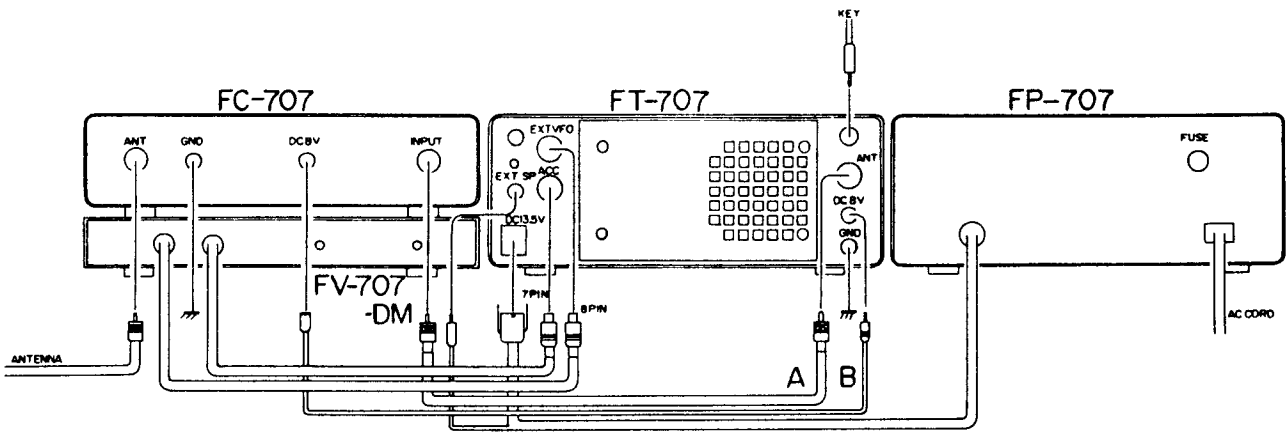

RELAY BOX FRB-707

The FRB-707 Relay Box is designed for the interconnection of the FT-707 with either the FL-2100Z linear amplifier or the FTV-107R transverter. For the connection of the FT-707 series using the FRB-707 Relay Box, please refer to the figure below:

this relay box, whenever the FTV-107R transverter is on.

FL-2100Z (Not available in USA)

When connecting the FL-2100Z linear amplifier, the TX-GND line should be connected to ground when the FT-707 is transmitting.

NOTE: The FT-707 transceiver does not have an external ALC input terminal. Therefore, carefully adjust the CAR control so as not to exceed 500 mA on the IC meter of the FL-2100Z. For SSB mode, 300 mA is acceptable (at voice peaks, the deflection may be 500 mA). During AM mode, adjust the carrier control so as not to exceed 200 mA. For further details regarding proper operation, please refer to the Instruction Manuals for both the FT-707 and FL-2100Z.

FTV-107R

When the FTV-107R is connected to the FT-707 with the FRB-707 Relay box, the TX/RX control line from the transverter is controlled by the relay box, and while the transverter is activated, the power line for the final amplifier in the FT-707 is switched off.

FC-707 + FTV-107R

When the FC-707 and FTV-107R are connected to the FT-707, the required +8V is supplied through

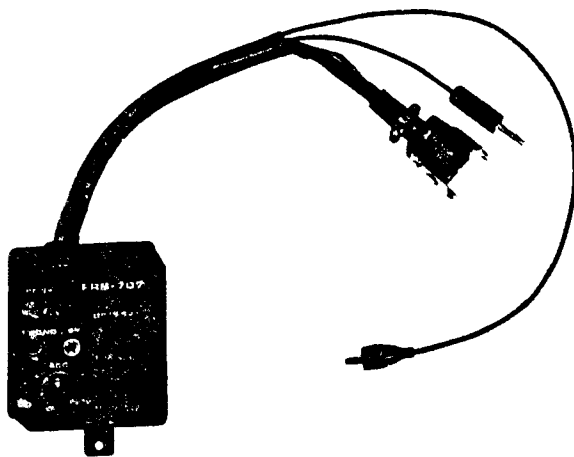

FRB-707

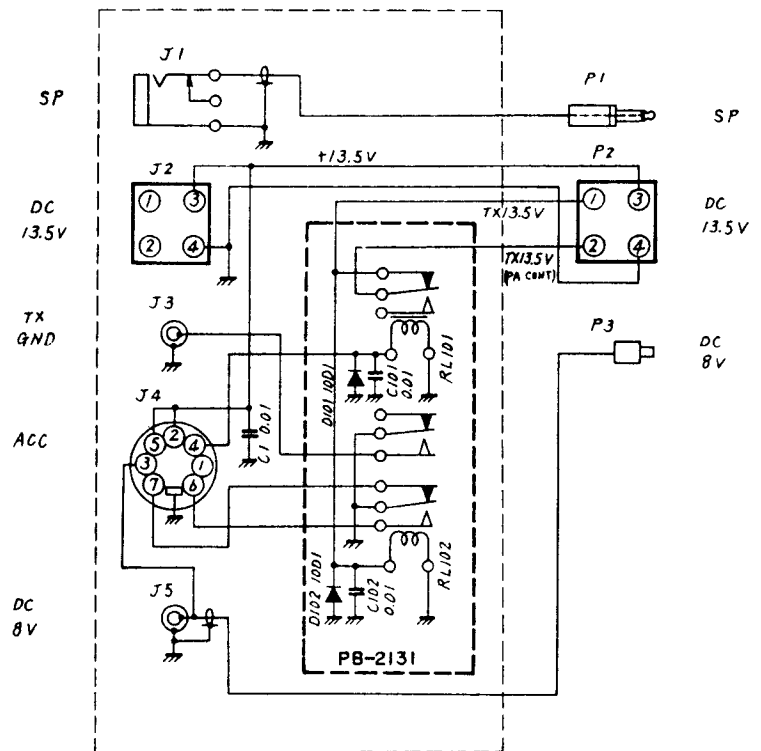

ANTENNA TUNER FC-707

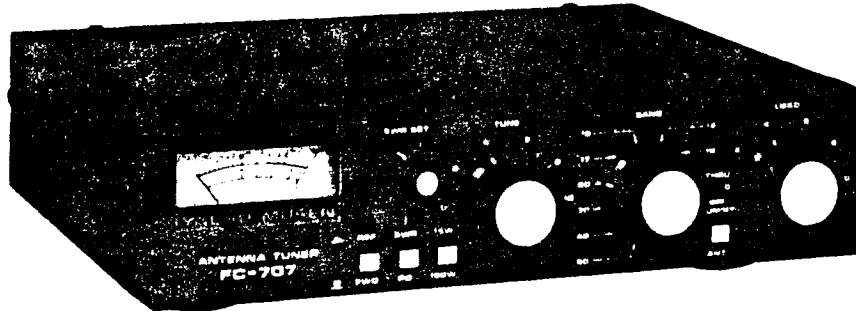

FC-707

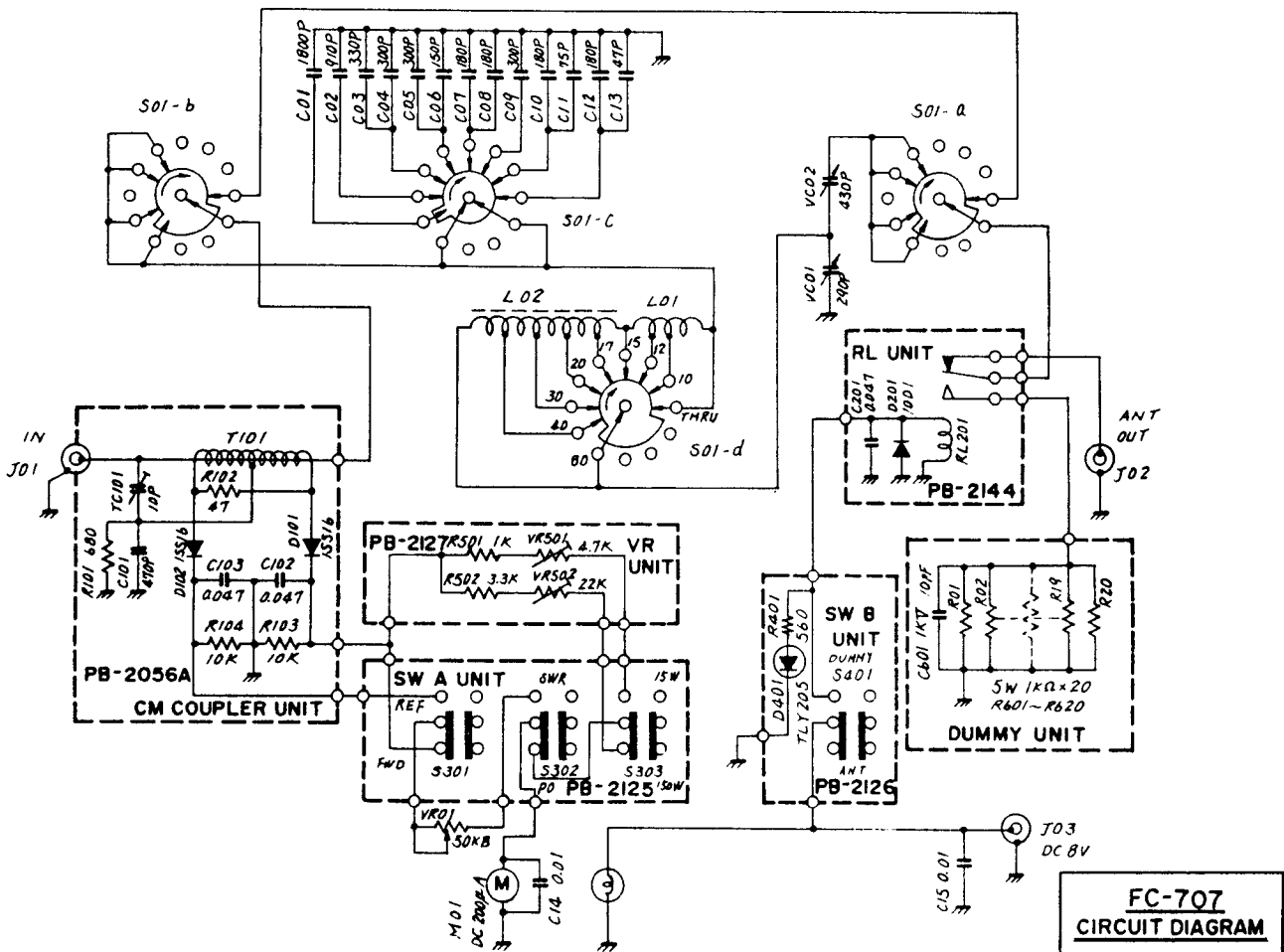

FC-707
CIRCUIT DIAGRAM

OPERATION

The all solid state design of the FT-707 means that tuning procedures are minimal. However, care should be exercised in operation to ensure that spurious signals are not generated by an improperly-adjusted transmitter. The following paragraphs will describe the tuning procedure for receiver and transmitter operation.

INITIAL CHECK

Before turning the transceiver on, confirm once again that all interconnections, power supply voltages, and fuses are correct.

FREQUENCY DETERMINATION

Frequency display on the FT-707 is by means of digital as well as analog display. The digital display is a true frequency counter, so no recalibration is required when changing bands.

The analog display may be aligned by direct comparison to the digital display. Note that the lower band edge of the 40, 30, 20, 17, 15, and 10 meter A and C bands corresponds to a starting frequency of 000 (e.g. 14.000 MHz) on the dial. On the 80, 12, and 10 meter B and D bands, the lower band edge begins at 500 (e.g. 3.500 MHz).

RECEIVE OPERATION

(1) Preset the controls and switches as follows:

MODE Desired mode
 AF GAIN Adjust subsequently for a comfortable level
 RF GAIN Fully clockwise
 WIDTH 12 o'clock position
 BAND Desired band
 DIAL Desired frequency
 SELECT switches . All should be off initially

(2) Be certain that a 50 ohm antenna or dummy load is connected to the antenna jack.

(3) Set the transceiver POWER switch to ON. If you are using the FP-707 AC Power Supply, slip the FP-707 power switch on first, then turn on the transceiver.

(4) Adjust the AF GAIN control for a comfortable volume level. The frequency will be displayed on the digital display, and you may adjust the main dial for the desired operating frequency. Note that all receiver preselector networks are preset for each band, and no adjustment is required for peak performance.

(5) When pulse-type noise is encountered, push the NB (Noise Blanker) switch. While no noise blanker will eliminate all types of noise (such as atmospheric or cosmic noise), the FT-707 noise blanker is a state-of-the-art design which should effectively eliminate most types of automotive ignition noise.

(6) The WIDTH control may be used to adjust the width of the IF passband. In the receiver IF, two 8 pole SSB filters are used. The signal frequency at one of the filters is varied, using a mixing technique that produces no change in the beat tone of the incoming signal.

The WIDTH control is especially useful in eliminating high-pitched "buckshot" on SSB, but it may also be used effectively on CW as well: for example, if the 350 Hz optional CW filter is used, the WIDTH control may be used in the CW-W position to provide an intermediate bandwidth (e.g. 800 Hz). You may then switch between the 800 Hz bandwidth (CW-W) or 350 Hz bandwidth (CW-N) by appropriate setting of the MODE switch.

(7) If the station you are working begins to drift, push the CLAR select switch to activate the clarifier control. You may then follow the drifting signal, up to a maximum of ± 3 kHz.

TRANSMITTER OPERATION

The discussion of the operation of the transmitter will be on a mode-by-mode basis.

It is important that an antenna or 50 ohm dummy load be connected to the antenna jack at all times.

Never switch any of the front panel switches (BAND, MODE, SELECT, etc.) while transmitting. It is possible to damage this equipment by ignoring this simple precaution.

GENERAL

Never transmit "key down" for more than 30 seconds at a time. If you transmit for 30 seconds, we recommend a rest period of at least two minutes before the next transmission. The final amplifier contains a heat sensing protection system, which will reduce the power output if the temperature of the final transistors becomes too high.

SSB MODE

(1) Preset the controls and switches as follows:

MODE Desired mode, LSB or USB
ALC ON (switch pushed)
MIC GAIN . . . Set to the 10 o'clock position
CAR Fully counterclockwise

(2) Close the microphone PTT switch.

(3) Speak in a normal voice into the microphone, and note the reading on the level meter. On voice peaks, the ALC indication should not illuminate any of the yellow LEDs. If the LEDs become consistently illuminated, retard the setting of the MIC GAIN control.

(4) If you push the ALC switch again, the relative PO meter will be activated. In this case, 5 LEDs should become illuminated on voice peaks.

(5) Release the PTT switch for receiver recovery.

(6) For VOX operation, advance the front panel VOX control until your voice activates the transmitter (PTT switch released). You may then adjust the front panel DELAY control to obtain the desired relay hang time. If the speaker output activates the VOX, you may have the VOX control advanced too far. Otherwise, the ANTITRIP control inside the cabinet may require adjustment; see the "Maintenance and Alignment" section of this manual for details.

CW MODE

(1) Set the MODE switch to CW-W or CW-N, and set the VOX control fully counterclockwise. Insert your key lead into the rear panel KEY jack.

(2) Push the front panel MOX switch (or close your footswitch, if used), and close your key. The sidetone will be heard in the speaker. Advance the CAR control until the desired power level is obtained. Maximum power output occurs when 8 LEDs are lit up.

(3) To adjust the CW semi-break-in circuit, advance the VOX control so that the CW sidetone activates the transmitter when you close your key. Adjust the DELAY control to provide the desired relay hang time.

(4) For QRP operation, the CAR control will provide adjustment of the power output level, down to 10 watts. An in-line wattmeter may be used for precise power measurement.

(5) When the 600 Hz or 350 Hz CW filter is installed, set the MODE switch to CW-N (narrow) to select the 6 pole CW filter. When the MODE switch is set to CW-W, the SSB filter will be selected. As noted earlier in this chapter, it is possible to use the WIDTH control to good advantage in providing a variety of bandwidths in the CW-W position.

AM MODE

(1) Set the MODE switch to AM, the ALC switch OFF, and rotate the MIC GAIN and CAR controls fully counterclockwise.

(2) Close the PTT switch, and advance the CAR control until 4 LEDs light up.

(3) Set the ALC switch ON, and speak into the microphone in a normal voice, and advance the MIC GAIN control until the first LED lights up dimly.

SECTION 2 — TECHNICAL NOTES

| | |
|------------------------------------|-----|
| SIGNAL TRACING IN THE FT-707 | 2-1 |
| RX FREQUENCY RELATIONSHIPS | 2-6 |
| CRYSTAL DATA | 2-6 |
| TX CONTROL LINE CIRCUIT | 2-7 |
| CIRCUIT DESCRIPTION | 2-8 |

SSB / CW MODE RX

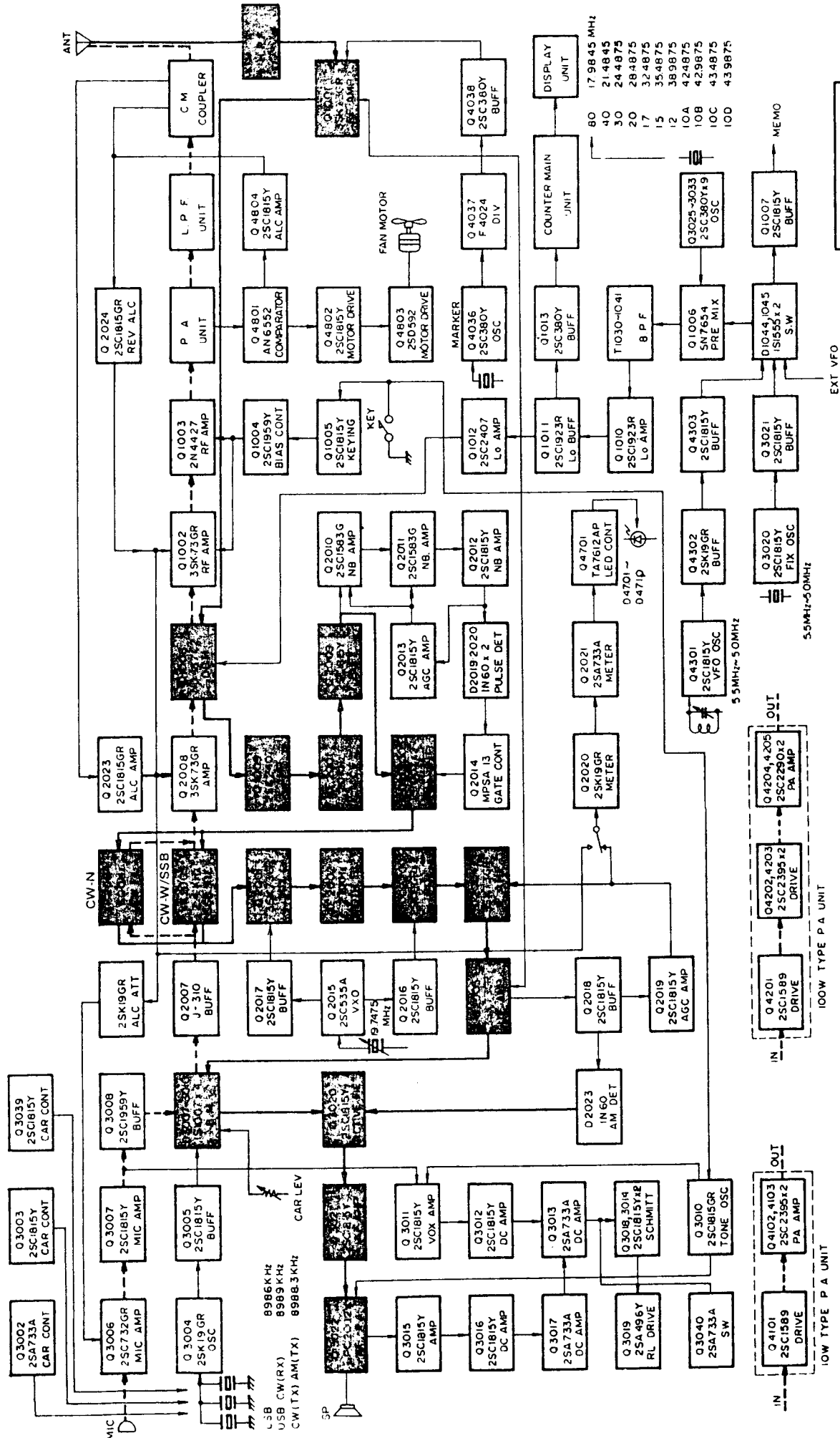

FT-707 Series
BLOCK DIAGRAM

EXT VFO

100W TYPE P A UNIT

LOW TYPE P A UNIT

RECEIVE
TRANSMIT
CONTROL

AM MODE RX

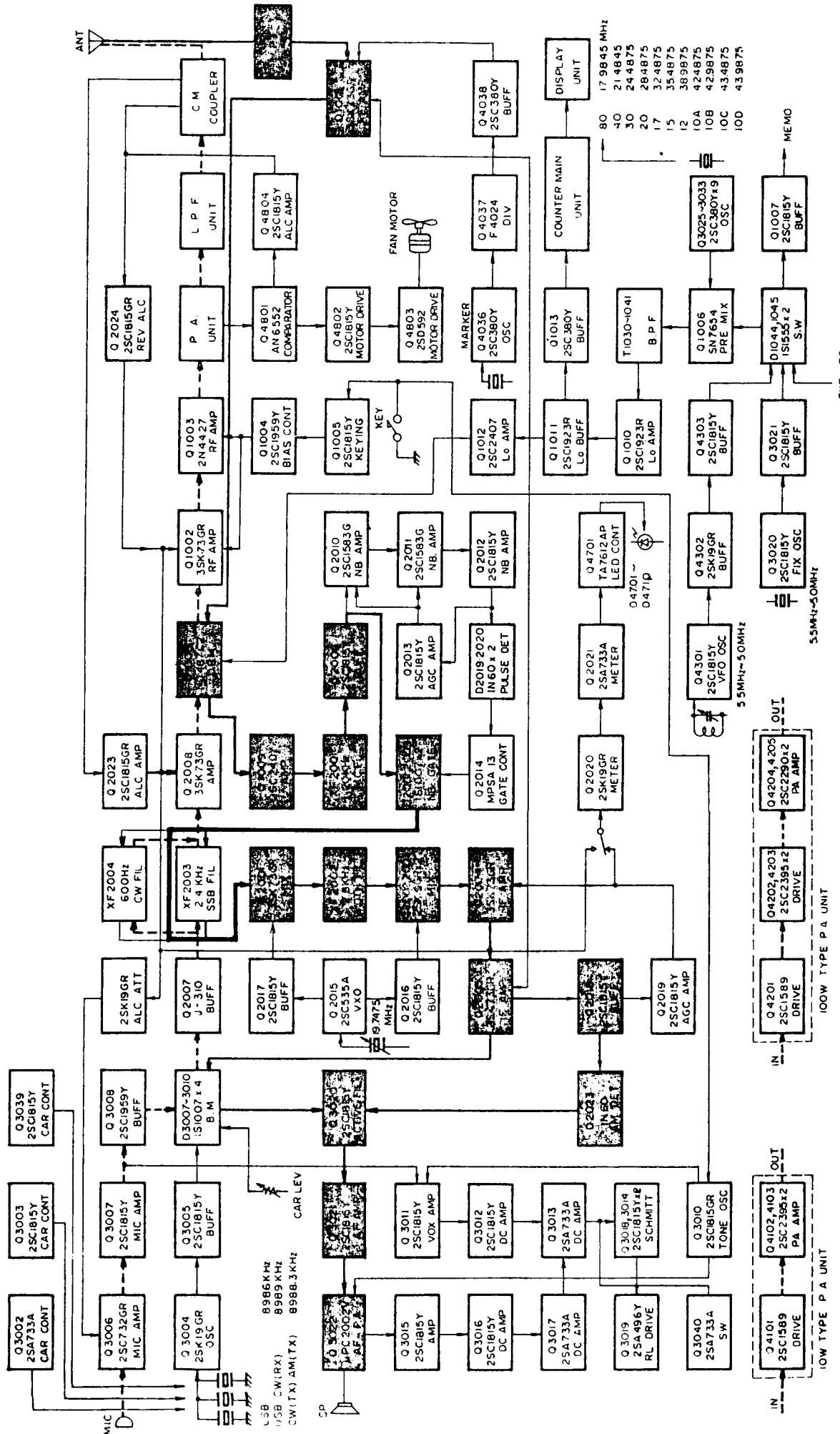

FT-707 Series
BLOCK DIAGRAM

RECEIVE
TRANSMIT
CONTROL

AM MODE TX

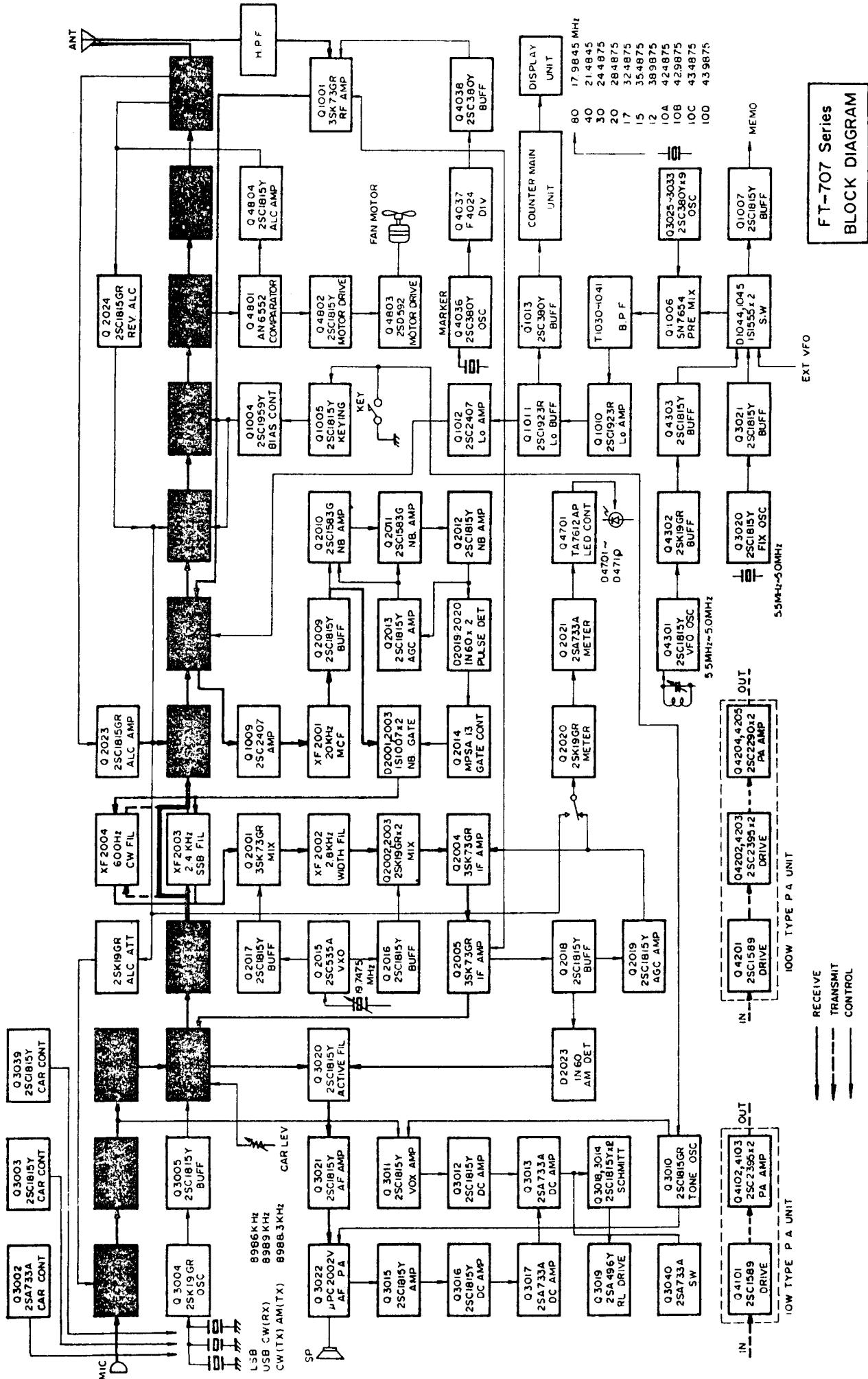

FT-707 Series
BLOCK DIAGRAM

EXT VFO

RECEIVE
TRANSMIT
CONTROL

100W TYPE P A UNIT

100W TYPE P A UNIT

RX FREQUENCY RELATIONSHIPS

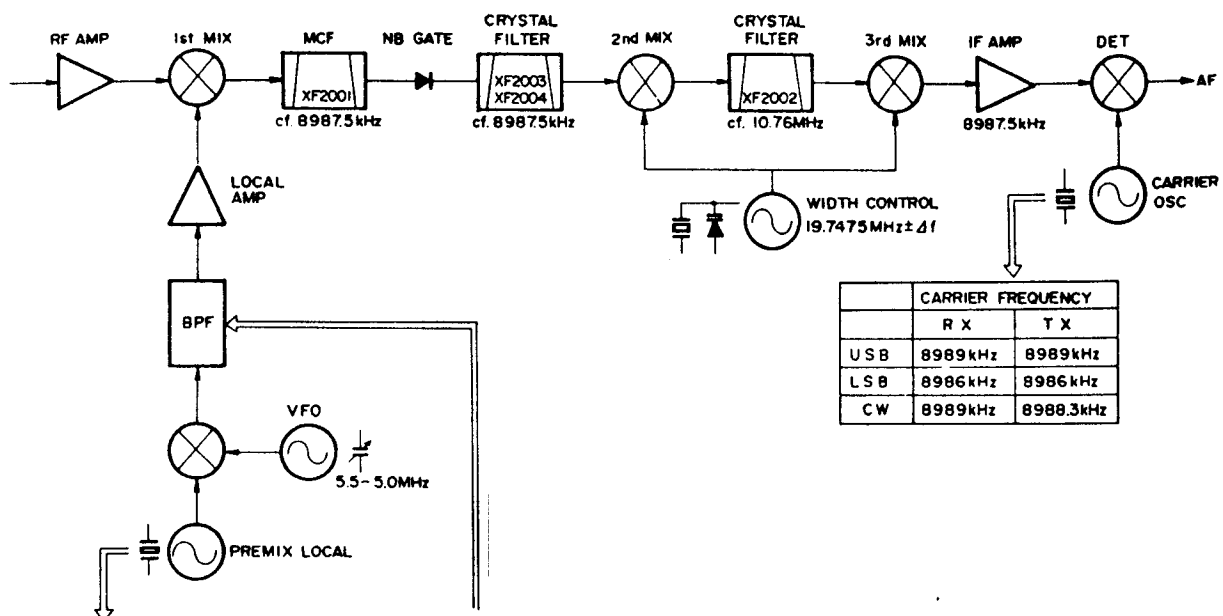

| BAND | FREQUENCY |
|------|------------|
| 80m | 17.9845MHz |
| 40m | 21.4845MHz |
| 30m | 24.4875MHz |
| 20m | 28.4875MHz |
| 17m | 32.4875MHz |
| 15m | 35.4875MHz |
| 12m | 38.9875MHz |
| 10mA | 42.4875MHz |
| 10mB | 42.9875MHz |
| 10mC | 43.4875MHz |
| 10mD | 43.9875MHz |

| BAND | RANGE |
|------|----------------------|
| 80m | 12.4875 — 12.9875MHz |
| 40m | 15.9875 — 16.4875MHz |
| 30m | 18.9875 — 19.4875MHz |
| 20m | 22.9875 — 23.4875MHz |
| 17m | 26.9875 — 27.4875MHz |
| 15m | 29.9875 — 30.4875MHz |
| 12m | 33.4875 — 33.9875MHz |
| 10m | 36.9875 — 38.9875MHz |

CRYSTAL DATA: FT-707

| UNIT | FUNCTION | HOLDER | FREQUENCY (kHz) | MODE | LOAD C (pF) | EFFECTIVE RESISTANCE (ohms) | DRIVE LEVEL (mw) |
|-------------|----------|---------|-----------------|--------------|-------------|-----------------------------|------------------|
| LOCAL | 160m | HC-18/U | 15984.5 | 3rd overtone | 20 | 80 | 2 |
| | 80m | " | 17984.5 | " | " | 60 | " |
| | 40m | " | 21484.5 | " | " | 45 | " |
| | 30m | " | 24487.5 | " | " | 40 | " |
| | 20m | " | 28487.5 | " | " | 40 | " |
| | 17m | " | 32487.5 | " | " | 40 | " |
| | 15m | " | 35487.5 | " | " | 40 | " |
| | 12m | " | 38987.5 | " | " | 40 | " |
| | 10m(A) | " | 42487.5 | " | " | 40 | " |
| | 10m(B) | " | 42987.5 | " | " | 40 | " |
| AF | LSB | " | 8986.0 | Fundamental | 30 | 35 | 10 |
| | USB | " | 8989.0 | " | " | " | " |
| | CW, AM | " | 8988.3 | " | " | " | " |
| FILTER | Width | " | ※19747.5 | Fundamental | 35 | 15 | 2 |
| RF | Marker | HC-6/W | 3200.0 | Fundamental | 23 | 50 | 5 |
| LSI COUNTER | Clock | HC-18/U | 6553.6 | Fundamental | 30 | 30 | 2 |

* XCO FREQUENCY: 19743-19753kHz
Determined by circuit

TX CONTROL LINE CIRCUIT

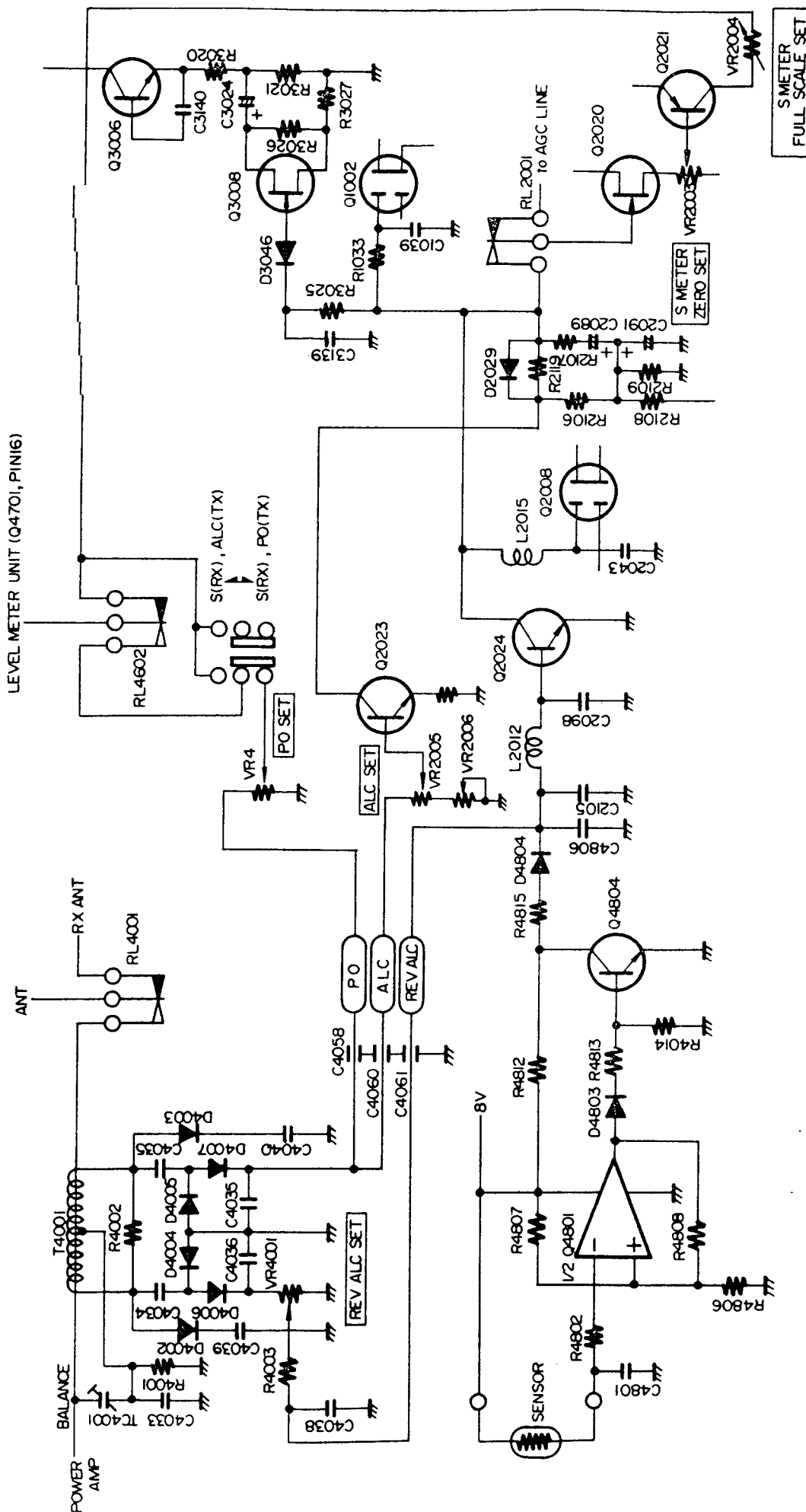

CIRCUIT DESCRIPTION

The block diagram and circuit description to follow, will provide you with a better understanding of this transceiver. Please refer to the schematic diagram for specific component details.

RECEIVER

The RF input signal from the antenna is fed through relay RL_{4001} (LPF Unit), lamp fuse F_{4801} (FAN MOTOR Unit), and passed through a high-pass filter of $f_c = 1.7$ MHz on the FAN MOTOR Unit. The signal is then delivered to pin 1 of J_{1002} on the RF Unit.

The signal is passed through individual antenna coils for each band and a 9 MHz trap, and amplified by Q_{1001} (3SK73GR), a dual gate MOS FET with excellent rejection of cross modulation and intermodulation. The amplified signal is fed through diode switched bandpass filter networks, which protect the mixer from out-of-band signals.

The RF signal is fed to the Schottky barrier diode ring module, Q_{1008} (ND487C2-3R), where the RF signal is mixed with a local signal delivered from Q_{1012} (2SC2407), resulting in a first IF of 8.9875 MHz. The input and output of the diode ring are protected by 50 ohm attenuators, which stabilize the input and output terminations for optimum intercept characteristics. The IF signal is then amplified by mixer post-amp Q_{1009} (2SC2407) and fed to pin 5 of J_{1001} for delivery to the IF Unit.

The local signal for the mixer is derived in the following manner: the incoming VFO signal from the VFO Unit is mixed with a crystal controlled local signal from the AF Unit at Q_{1006} (SN76514N) and fed through bandpass filter networks for each band, which remove any spurious responses outside of the desired band. The signal is then amplified by Q_{1011} , Q_{1012} (2SC1923R), and Q_{1012} (2SC2407) and fed to the LO port of the diode ring. The premix local signal is generated by $Q_{3025} - Q_{3033}$ (2SC380TMY), located on the AF Unit.

The 8.9875 MHz IF signal is fed to pin 5 of J_{2001} . The signal is passed through XF_{2001} , a 20 kHz monolithic crystal filter which provides early protection against IMD while allowing enough bandwidth and delay time to match the noise

blanker gate pulses. The signal then passes through noise blanker diodes D_{2001} and D_{2003} , which act as a switch driven by noise blanker controller Q_{2014} (MPSA13). The IF signal then is fed through the main SSB or CW filter (CW filter optional); on AM, the signal passes around the SSB/CW filter.

The filtered IF signal is delivered to mixer Q_{2001} (3SK73GR), where the 8.9875 MHz IF signal is mixed with a 19.7475 MHz $\pm\Delta f$ local signal delivered from oscillator Q_{2015} (2SC535A) and buffer Q_{2016} (2SC1815Y). The resulting 10.76 MHz signal is fed through crystal filter XF_{2002} , then fed to mixer Q_{2002}/Q_{2003} (2SK19GR), where the 10.76 MHz signal is mixed with an identical 19.7475 MHz $\pm\Delta f$ signal fed from buffer Q_{2017} (2SC1815Y), resulting in an 8.9875 MHz signal, the same as the original IF. This process varies the IF across the passband of crystal filter XF_{2002} , resulting in continuously variable width of the IF passband with no change in the beat note of the incoming signal.

The IF signal is then amplified by Q_{2004} and Q_{2005} (3SK73GR), the main IF amplifiers, and delivered to pin 2 of J_{2002} for delivery to the AF Unit.

A portion of the output from Q_{2005} is fed to buffer Q_{2018} (2SC1815Y) and detected by D_{2024} and D_{2025} (1N60), resulting in a DC voltage. This voltage is amplified by Q_{2019} (2SC1815Y) and fed to gate 2 of the RF and IF amplifiers, providing automatic gain control of those stages. The AGC voltage is also amplified by Q_{2020} (2SK19GR) and Q_{2031} (2SA733A) for delivery to the front panel LED display for indication of the received signal strength.

When the noise blanker is switched on, a portion of the output from Q_{2009} is amplified by Q_{2010} , Q_{2011} (2SC1583G) and Q_{2012} (2SC1815Y). When a carrier or noise-free modulated signal is received, the IF signal is rectified by D_{2017} and D_{2018} (1N60), producing a DC voltage. This DC voltage is amplified by Q_{2013} (2SC1815Y), which charges C_{2063} for AGC purposes. The AGC voltage is used to control the gain of Q_{2010} and Q_{2011} .

When impulse-type noise is received, D_{2019} and D_{2020} (1N60) rectify the IF signal, which controls the noise blanker switch, Q_{2014} .

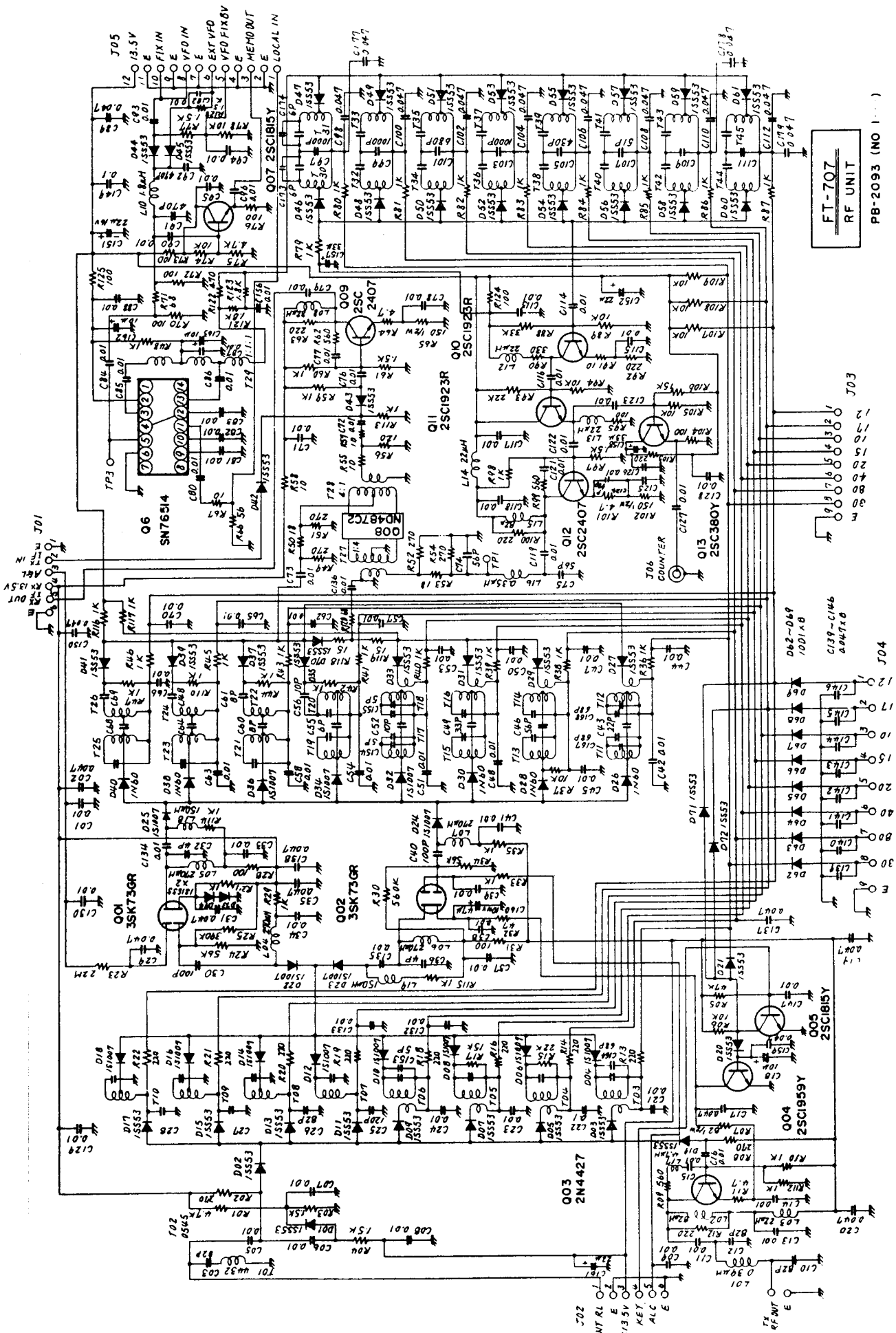

FT-707
RF UNIT

PB-2093 (NO 1...)

Early model

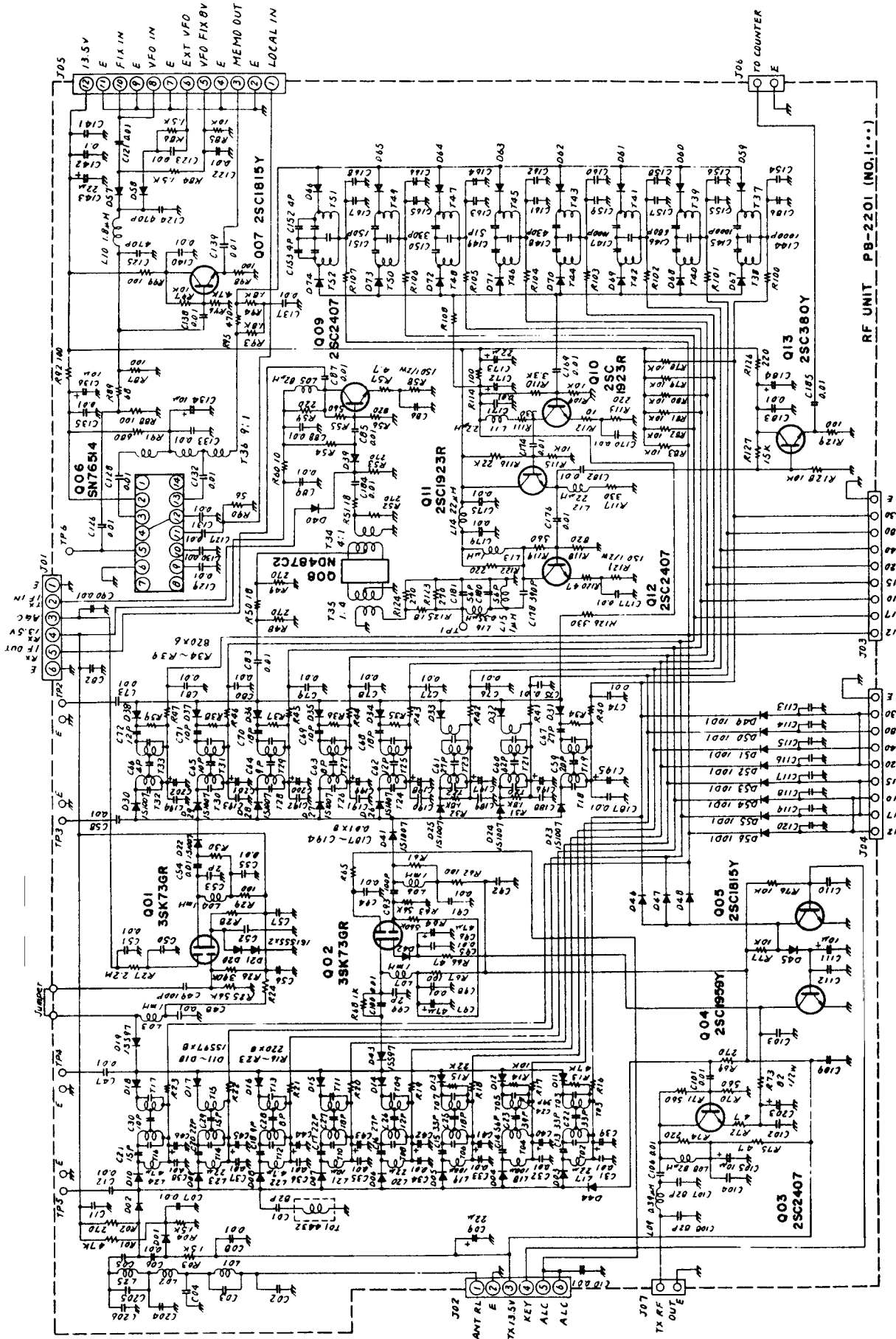

ET-707
RF UNIT

After prod. 11

- NOTES
- 1 ALL RESISTORS ARE 1/4W UNLESS OTHERWISE NOTED
 - 2 ALL CAPACITORS ARE 0.047UF UNLESS OTHERWISE NOTED
 - 3 ALL ELECTROLYTIC CAPACITORS ARE 33MF OTHERWISE NOTED
 - 4 ALL DIODES ARE 1SS53 UNLESS OTHERWISE NOTED

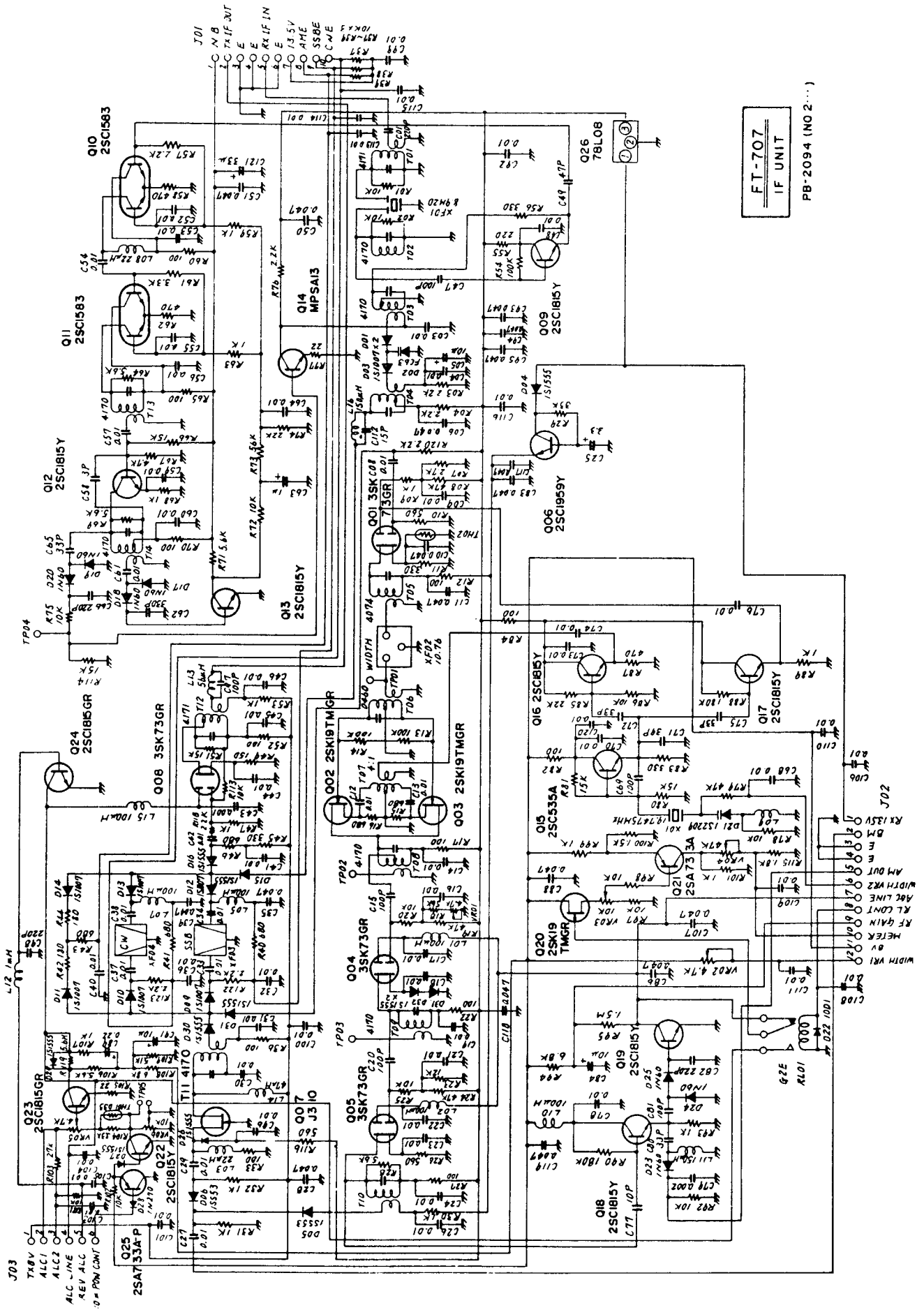

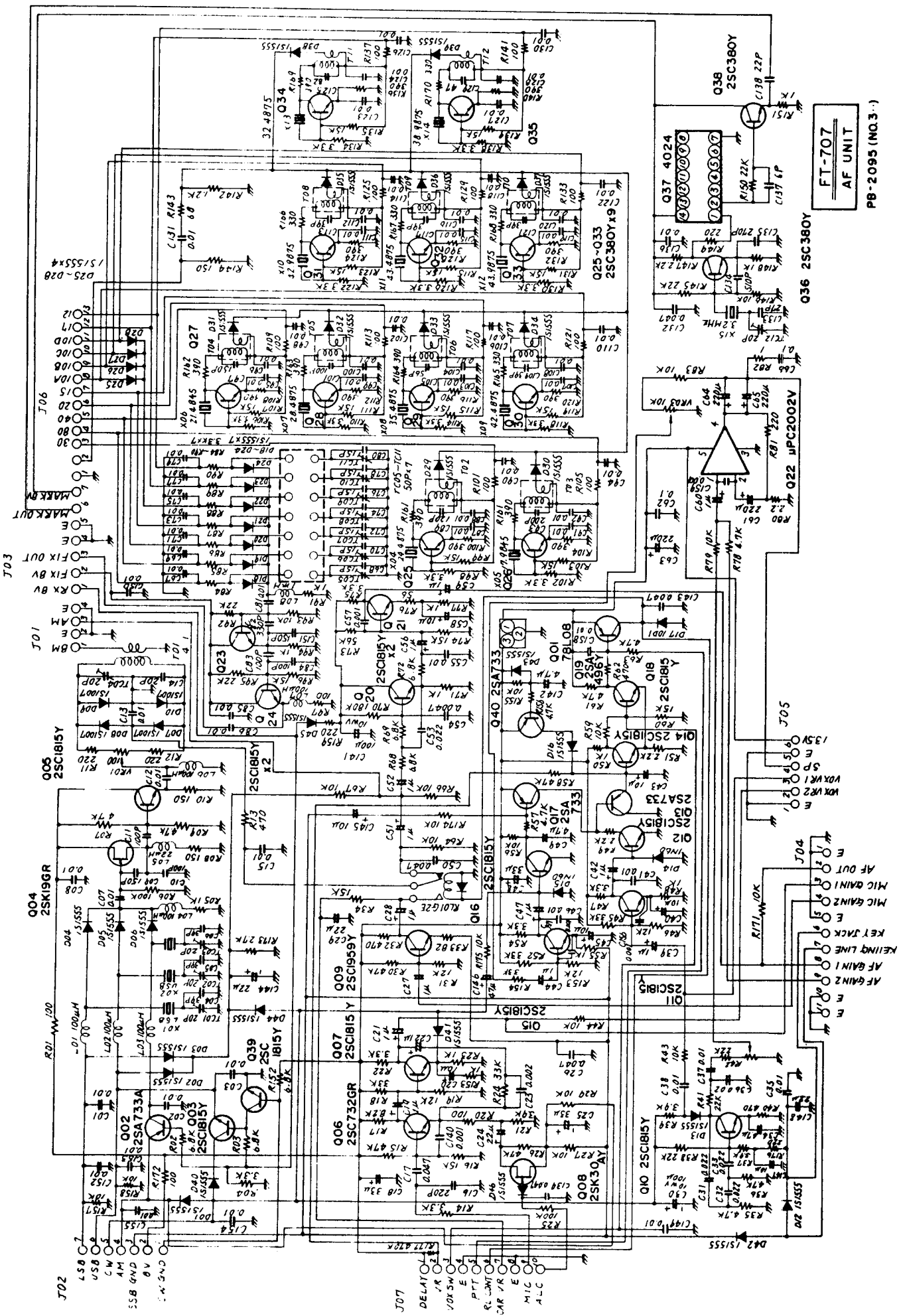

FT-707
AF UNIT

PB-2095 (NO. 3)

Noise pulses have a very short duration, but high amplitude. Because of the very short time constant of the C_{2063}/R_{2072} discharge path, AGC voltage is not induced by these short-duration pulses. Therefore, Q_{2010} and Q_{2011} operate at full gain, providing maximum voltage to the base of Q_{2014} . When a pulse is received, therefore, Q_{2014} biases D_{2001} and D_{2003} to block the signal path momentarily. When a desired signal and a noise pulse are received simultaneously, the blanking action is not impaired, because the relative difference between the desired signal and the noise pulse is still high.

In the AM mode, a portion of the output from Q_{2018} is detected by D_{2023} (1N60) and delivered to the AF Unit. Filtering in the AM mode is accomplished by XF_{2002} .

AF UNIT (PB-2095)

The SSB or CW signal at pin 1 of J_{3001} is fed through T_{3001} to the diode ring demodulator, $D_{3007}-D_{3010}$ (1S1007), where the IF signal is converted to audio using the carrier signal supplied by crystal oscillator Q_{3004} (2SK19GR) and buffer

Q_{3005} (2SC1815Y). The carrier oscillator provides signals at the following frequencies:

| | |
|---------------|------------|
| LSB | 8986 kHz |
| USB/CW(RX) | 8989 kHz |
| CW(TX)/AM(TX) | 8988.3 kHz |

The audio signal is amplified by Q_{3020} and Q_{3021} (2SC1815Y) and fed to final AF amplifier Q_{3022} (μ PC2002V), which provides three watts of audio output to the speaker through an output transformerless circuit.

The audio spectrum is shaped by an active low-pass filter at Q_{3020} of $f_c = 2.7$ kHz, -12 dB/octave.

MARKER GENERATOR

A 25 kHz marker generator is available, for alignment and testing purposes. Marker generator Q_{3036} (2SC380TMY) provides a basic 3200 kHz signal, which is divided into 25 kHz multiples by Q_{3037} (F4024), a binary counter. The output signal is fed through buffer Q_{3038} (2SC380TMY) to the receiver front end.

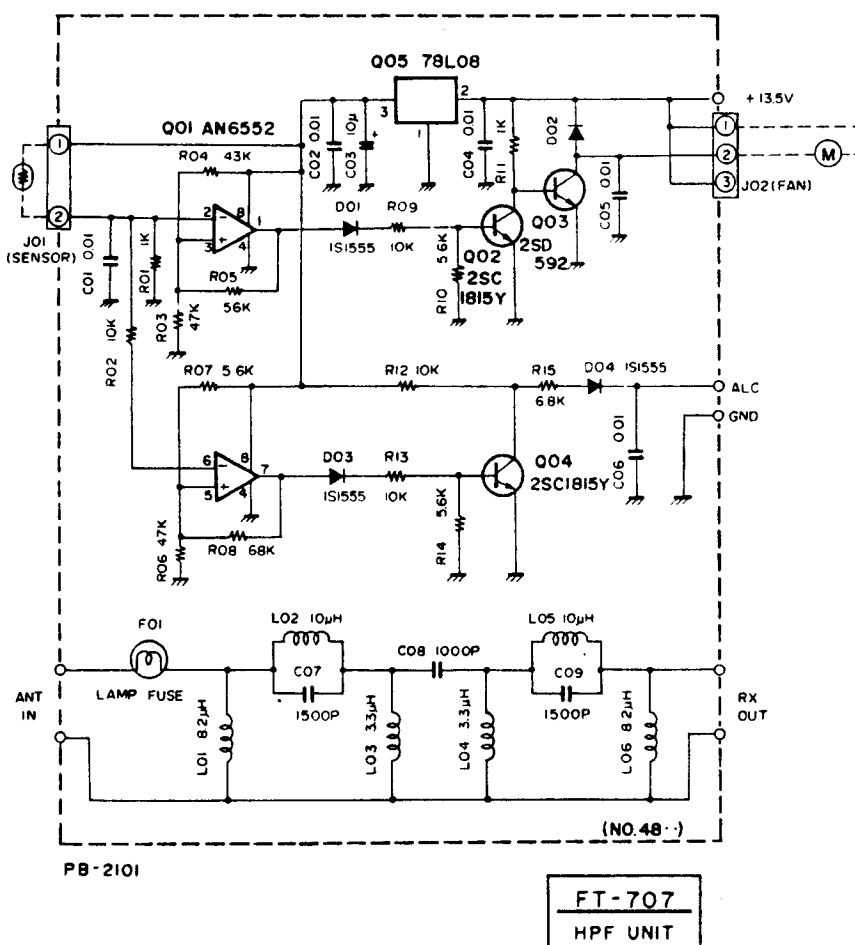

TRANSMITTER

The discussion of the signal flow on transmit will be on a mode-by-mode basis.

SSB

The audio input signal from the microphone jack, J₃, is fed to pin 9 of J₃₀₀₇ on the AF Unit. The speech signal is amplified by Q₃₀₀₆ (2SC732GR) and Q₃₀₀₇ (2SC1815Y) and then fed through the front panel MIC GAIN control, VR_{3b}. The signal is then applied through buffer Q₃₀₀₈ (2SC1959Y) to the ring modulator, D₃₀₀₇-D₃₀₁₀. Here the audio signal modulates the carrier signal delivered from Q₃₀₀₅, resulting in an 8.9875 MHz double-sideband signal. The signal is then fed to pin 1 of J₃₀₀₁ for delivery to the IF Unit.

The IF signal appearing at pin 2 of J₂₀₀₂ is fed through buffer Q₂₀₀₇ (J310) to the SSB filter, where the unwanted sideband is sliced out. The resulting SSB signal is amplified by Q₂₀₀₈ (3SK73GR) and delivered to the diode ring mixer, Q₁₀₀₈, where the IF signal is mixed with the local signal from the premix circuit. The RF signal is then amplified by Q₁₀₀₂ (3SK73GR) and Q₁₀₀₃ (2N4427), and delivered to the PA Unit.

The input signal is amplified by pre-driver Q₄₂₀₁ (2SC1589) and the push-pull driver stage, Q₄₂₀₂/Q₄₂₀₃ (2SC2395), and amplified further by the push-pull final amplifier, Q₄₂₀₂/Q₄₂₀₅ (2SC2290), which provides approximately 100 watts of RF output. The RF signal is fed through bandswitch low-pass filter networks on the LPF Unit, then delivered, through a directional coupler, to the rear panel antenna jack.

CW

For CW, the 8988.3 kHz carrier signal is generated by Q₃₀₀₄ and fed through buffer Q₃₀₀₅ to the ring modulator, which is unbalanced for CW operation by the application of DC 8V through D₃₀₀₁ (1S155) and RL₃₀₀₁. The signal path is then identical to that of the SSB signal, up to the latter stage of the RF Unit.

The key line is connected to the base of Q₁₀₀₅ (2SC1815Y). With the key open, Q₁₀₀₅ is biased ON, turning bias controller Q₁₀₀₄ (2SC1959Y) OFF. In this case, the emitters of Q₁₀₀₂ and Q₁₀₀₃ are open, and no output signal will result. When the key is closed, Q₁₀₀₄ will be turned ON, and Q₁₀₀₂ and Q₁₀₀₃ will be keyed, allowing normal transmission. The key lead is also connected to

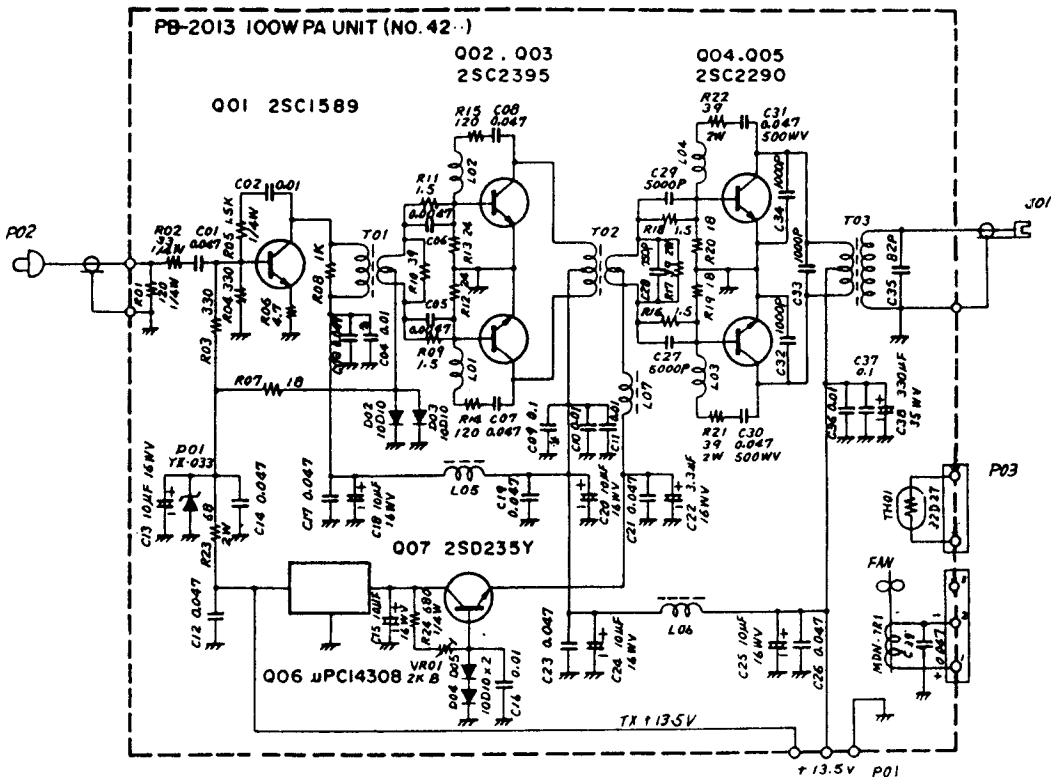

sidetone oscillator Q₃₀₁₀ (2SC1815Y), for monitoring of the code signal during CW operation. The output from Q₃₀₁₀ is delivered to the final AF amplifier, Q₃₀₂₂.

AM

The microphone signal modulates the 8988.3 kHz carrier signal, and the resulting signal is amplified by Q₂₀₀₇ and passed around the SSB filter. From Q₂₀₀₈, the signal path is the same as that on SSB.

ALC CIRCUIT

A variety of level control systems are included in the FT-707, for protection against overdrive, excess temperature, or high SWR.

At the directional coupler, the output voltage is sensed. When a high SWR condition exists, the voltage is detected by D₄₀₀₄ and D₄₀₀₆ (1SS16)

and amplified by Q₂₀₂₄ (2SC1815Y) and fed to the RF, IF, and AF stages of the transmitter, controlling the gain of those stages. In the case of overdrive, the ALC voltage is detected by D₄₀₀₅ and D₄₀₀₇ (1SS16) and amplified by Q₂₀₂₃ (2SC1815Y) for control of the aforementioned stages.

A thermistor on the final amplifier board provides detection of excess temperature. When the operating temperature of the final transistors rises to an unacceptable figure, control voltage developed at comparator Q₄₈₀₁ (AN6552) is fed to Q₄₈₀₂ (2SC1815Y), which drives Q₄₈₀₃ (2SD592), providing operating voltage for a cooling fan on the amplifier heat sink. Control voltage is also fed from Q₄₈₀₁ to amplifier Q₄₈₀₄ (2SC1815Y), and this voltage is delivered to the ALC line to the RF, IF, and AF stages.

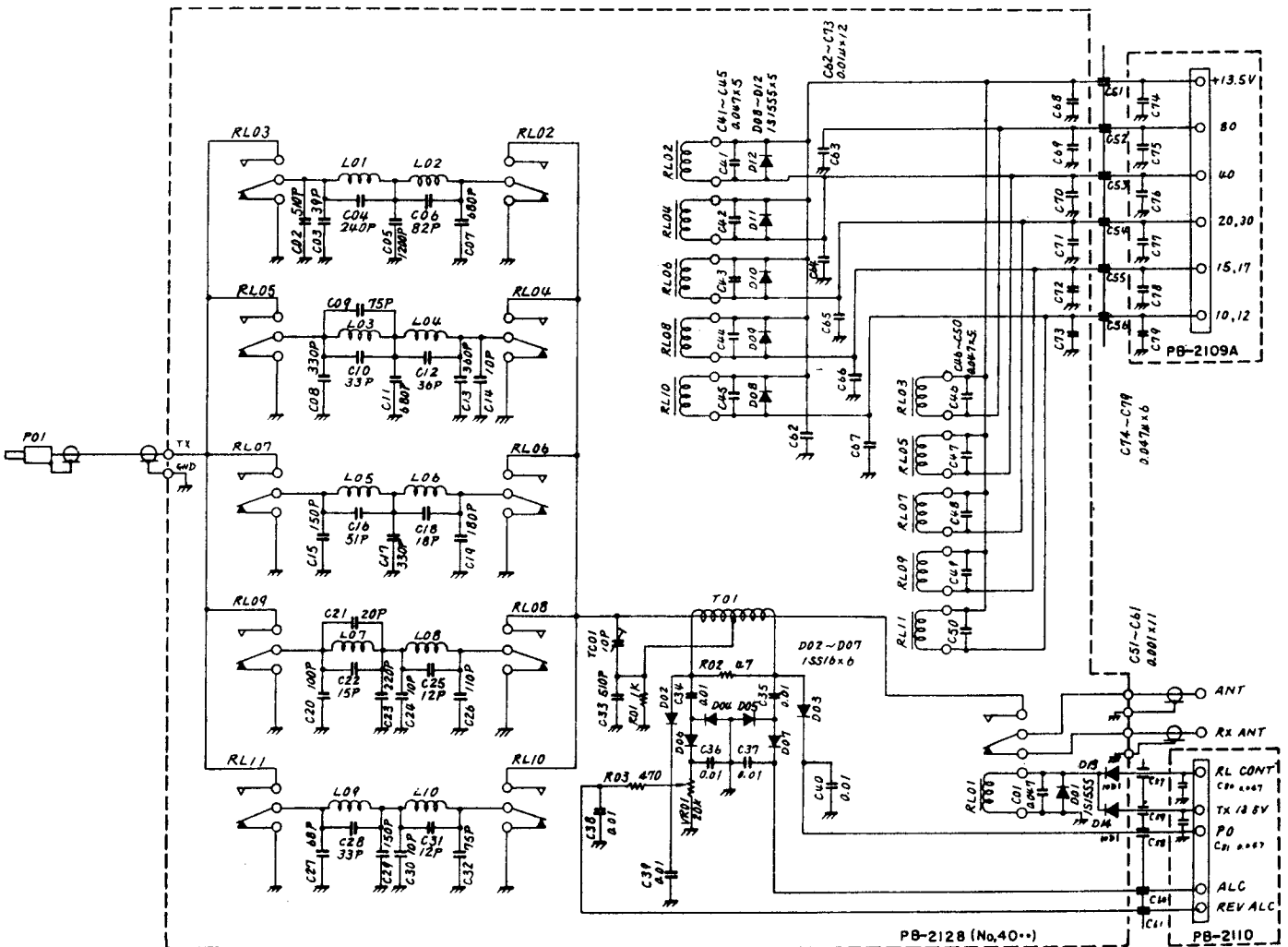

TECHNICAL NOTES

COMMON CIRCUIT

VOX circuit

A portion of the microphone input signal is amplified by Q₃₀₁₁ (2SY1815Y) and detected by D₃₀₁₄ (1N60), producing a DC voltage. This voltage is amplified by Q₃₀₁₂ (2SC1815Y) and Q₃₀₁₃ (2SA733). Q₃₀₁₃ drives Schmitt trigger Q₃₀₁₄/Q₃₀₁₈ (2SC1815Y); when Q₃₀₁₈ is driven ON, relay driver Q₃₀₁₉ (2SA496Y) is turned ON, activating the antenna relay. An RC circuit composed of front panel DELAY control VR₅₁₀₁ and C₃₀₄₃ sets the relay hang time by delaying the cutoff of Q₃₀₁₃ when speech input stops.

A portion of the speaker output is amplified by Q₃₀₁₅ (2SC1815Y) and detected by D₃₀₁₅ (1N60). This provides a bucking voltage which is amplified by Q₃₀₁₆ (2SC1815Y) and Q₃₀₁₇ (2SA733) and fed to Q₃₀₁₃, preventing the speaker output from tripping the VOX circuit.

VFO UNIT (PB-2097)

VFO oscillator Q₄₃₀₁ (2SC1815Y) operates in a modified Colpitts configuration, providing a 5.0–5.5 MHz VFO signal. The 500 kHz tuning range is tuned by variable capacitor VC₄₃₀₁, which is a two-section capacitor. The sub-blades of VC₄₃₀₁ provide temperature compensation against frequency change caused by thermal expansion of the main blades. The VFO signal is fed through buffer amplifiers Q₄₃₀₂ (2SK19GR) and Q₄₃₀₃ (2SC1815Y), passed through a low-pass filter, and fed, through diode switches D₁₀₄₄/D₁₀₄₅ (1S1555), to the premix IC, Q₁₀₀₆.

Varactor diode D₄₃₀₁ is placed in the oscillator circuit during clarifier operation. In accordance with the tuning of the front panel clarifier control and L₄₃₀₆, the capacitance variation induced in D₄₃₀₁ allows offset from the main dial frequency of ±2.5 kHz.

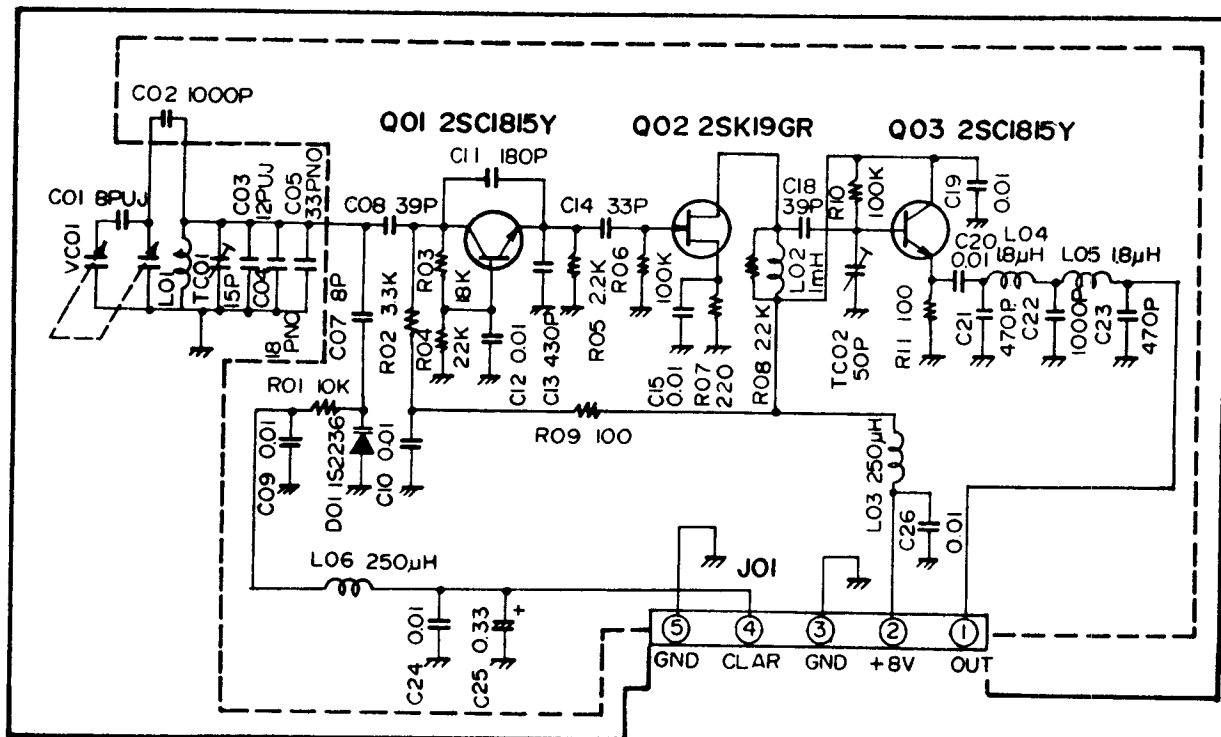

FT-707
VFO UNIT

PB-2097(NO.43..)

PREMIX CIRCUIT (AF UNIT)

The premix local signal is generated by crystal oscillator $Q_{3025} - Q_{3033}$ (2SC380TM-Y), the oscillator in use being selected by diode switches $D_{3029} - D_{3037}$ (1S1555). The output from the oscillator passes through Pin 2 of J_{1006} and Pin 1 of J_{1005} in the RF Unit. This signal is fed to Pin 11 of the IC double balanced mixer (Q_{1006}).

The 5.0-5.5 MHz VFO signal is fed through Pin 8 of J_{1005} , to the diode switch selecting either FIX or VFO, and to a low-pass filter. Next, this signal passes to the mixer, where the VFO signal is mixed up with the premix local signal, resulting in the output premix signal, shown in Table 3.

The premix signal is passed through a broadband transformer and a bandswitched bandpass filter, which eliminates spurious signals on the premix output. Selection of the desired filter is performed by the diode switches of $D_{1046} - D_{1057}$ (1SS53). The filtered signal is then amplified by a three-stage amplifier chain consisting of Q_{1010} , Q_{1011} (2SC1923R), and Q_{1012} (2SC2407). Finally, the signal is delivered to the double balanced mixer, which provides the TX and RX IF signal.

A portion of the output from Q_{1011} is amplified by buffer Q_{1013} (2SC380TM-Y) for delivery to the frequency counter for display purposes.

| | | XCO Frequency MHz | PREMIX OUT Frequency MHz |
|------|------------|----------------------|-----------------------------|
| 80m | X_{3005} | 17.9845 | 12.4875-12.9875 |
| 40m | X_{3006} | 21.4845 | 15.9875-16.4875 |
| 30m | X_{3004} | 24.4875 | 18.9875-19.4875 |
| 20m | X_{3007} | 28.4875 | 22.9875-23.4875 |
| 17m | X_{3013} | 32.4875 | 26.9875-27.4875 |
| 15m | X_{3008} | 35.4875 | 29.9875-30.4875 |
| 12m | X_{3014} | 38.9875 | 33.4875-33.9875 |
| 10mA | X_{3009} | 42.4875 | 36.9875-37.4875 |
| 10mB | X_{3010} | 42.9875 | 37.4875-37.9875 |
| 10mC | X_{3011} | 43.4875 | 37.9875-38.4875 |
| 10mD | X_{3012} | 43.9875 | 38.4875-38.9875 |

Table 2-1

| | Nominal Premix Local Frequency (MHz) | LSB (MHz) | USB (MHz) | CW. AM (MHz) |
|------|--|---------------|---------------|-----------------|
| 80m | 12.4875-12.9875 | 12.486-12.986 | 12.489-12.989 | 12.4883-12.9883 |
| 40m | 15.9875-16.4875 | 15.986-16.486 | 15.989-16.489 | 15.9883-16.4883 |
| 30m | 18.9875-19.4875 | 18.986-19.486 | 18.989-19.489 | 18.9883-19.4883 |
| 20m | 22.9875-23.4875 | 22.986-23.486 | 22.989-23.489 | 22.9883-23.4883 |
| 17m | 26.9875-27.4875 | 26.986-27.486 | 26.989-27.489 | 26.9883-27.4883 |
| 15m | 29.9875-30.4875 | 29.986-30.486 | 29.989-30.489 | 29.9883-30.4883 |
| 12m | 33.4875-33.9875 | 33.486-33.986 | 33.489-33.989 | 33.4883-33.9883 |
| 10mA | 36.9875-37.4875 | 36.986-37.486 | 36.989-37.489 | 36.9883-37.4883 |
| 10mB | 37.4875-37.9875 | 37.486-37.986 | 37.489-37.989 | 37.4883-37.9883 |
| 10mC | 37.9875-38.4875 | 37.986-38.486 | 37.989-38.489 | 37.9883-38.4883 |
| 10mD | 38.4875-38.9875 | 38.486-38.986 | 38.489-38.989 | 38.4883-38.9883 |

Table 2-2

COUNTER UNIT (PB-2086A)

A portion of the local oscillator signal appears at the F IN terminal of the COUNTER Unit, where it is amplified by Q₄₄₀₁ (3SK73) and Q₄₄₀₃ (2SC1674L). The signal is then fed to the LSI counter chip, Q₄₀₁₂ (MSM9520RS). A portion of the output from Q₄₄₀₃ is detected by D₄₄₀₁ and D₄₄₀₂ (1S1555) and amplified by Q₄₄₀₄

(2SC1815Y), providing an AGC voltage which keeps the signal input level to the LSI constant by controlling the gain of Q₄₄₀₁.

The output from the LSI drives LED digit drivers Q₄₄₀₆ - Q₄₄₁₁ (2SA952L) and segment drivers Q₄₄₁₃ - Q₄₄₁₉ (2SA952L), which control the digital display light emitting diodes, D₄₅₀₁ - D₄₅₀₆ (HP5082-7623).

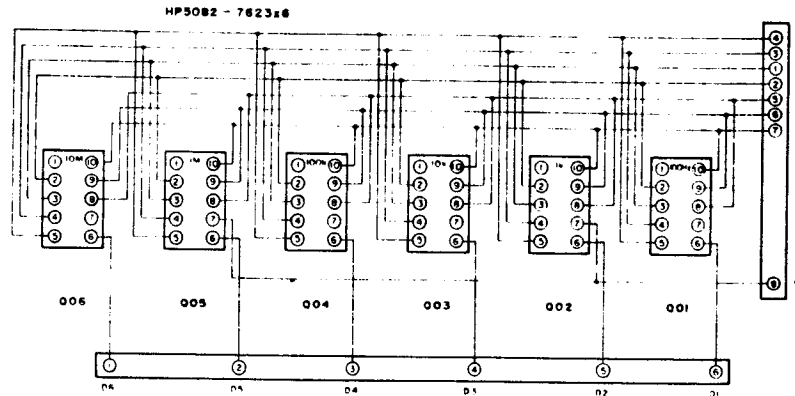

DISPLAY UNIT PB-2098

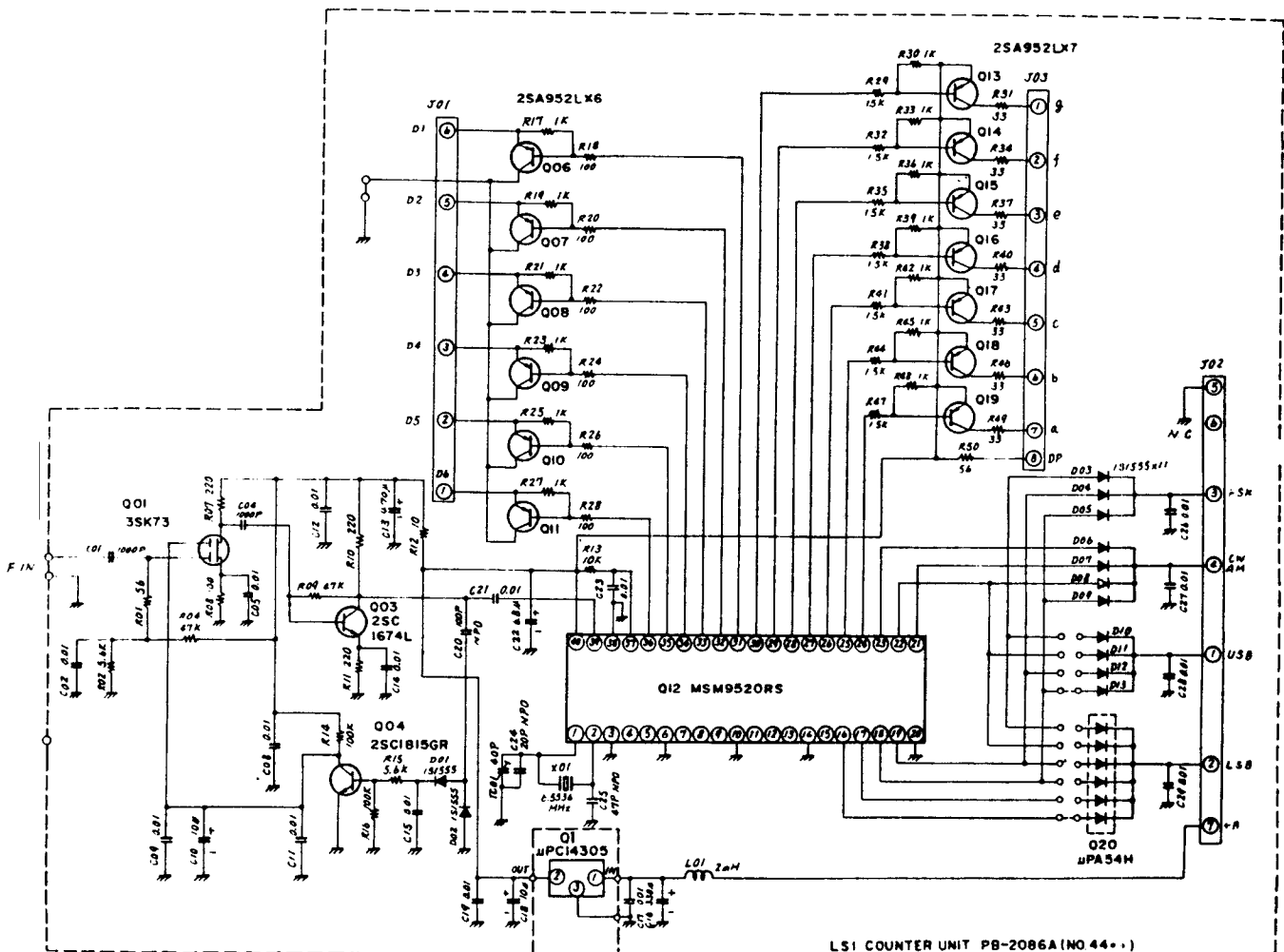

LSI COUNTER UNIT PB-2086A (NO 44-)

MEMO

MEMO

SECTION 3—SERVICING

| | |
|---|------|
| OUTER COVER REMOVAL | 3-1 |
| FRONT PANEL REMOVAL | 3-2 |
| REAR PANEL REMOVAL | 3-4 |
| 100W PA UNIT REMOVAL | 3-5 |
| MAIN CHASSIS EXPLODED VIEW | 3-6 |
| BOARD LAYOUT | 3-7 |
| SOLDERING AND DESOLDERING TECHNIQUE | 3-9 |
| CIRCUIT TRACE REPAIR | 3-10 |
| INSTALLATION: OPTIONS | |
| CW FILTER INSTALLATION | 3-12 |
| FIX (CRYSTAL CONTROLLED) OPERATION | 3-13 |
| MODIFICATIONS | |
| S/N IMPROVEMENT ON 80M BAND | 3-14 |
| MODIFICATION TO ELIMINATE "CLICKING" NOISE ON CW | 3-14 |
| TX IMD DISTORTION IMPROVEMENT | 3-15 |
| MARKER MODIFICATION | 3-16 |
| PREMIX MODIFICATION | 3-16 |
| RECEIVER INPUT CIRCUIT MODIFICATION | 3-17 |
| WARC TX MODIFICATION | 3-18 |
| FREQUENCY COUNTER PRESET CHANGE | 3-19 |
| MAINTENANCE AND ALIGNMENT | 3-21 |
| FAULT IDENTIFICATION AND LOCALIZATION | 3-29 |
| TROUBLESHOOTING | 3-30 |
| RELAY CONNECTION INFORMATION | 3-36 |
| CIRCUIT BOARD LAYOUT AND TEST VOLTAGE | |
| RF UNIT (PB-2093A/PB-2201) | 3-37 |
| IF UNIT (PB-2094A) | 3-43 |
| AF UNIT (PB-2095A) | 3-46 |
| AVR UNIT (PB-2099A) | 3-49 |
| COUNTER/DISPLAY UNIT (PB-2086A-3540/PB-2098-3540) | 3-50 |
| VFO ASSEMBLY (PB-2097A) | 3-54 |
| 100W PA UNIT (PB-2013) | 3-58 |
| HPF/FAN MOTOR CONTROL UNIT (PB-2101) | 3-61 |
| LEVEL METER UNIT (PB-2100) | 3-62 |
| SW UNIT (PB-2102) | 3-63 |
| VR UNIT (PB-2103A) | 3-63 |
| SWITCH ASSEMBLIES | 3-64 |
| POTENTIOMETER ASSEMBLIES | 3-65 |

OUTER COVER REMOVAL

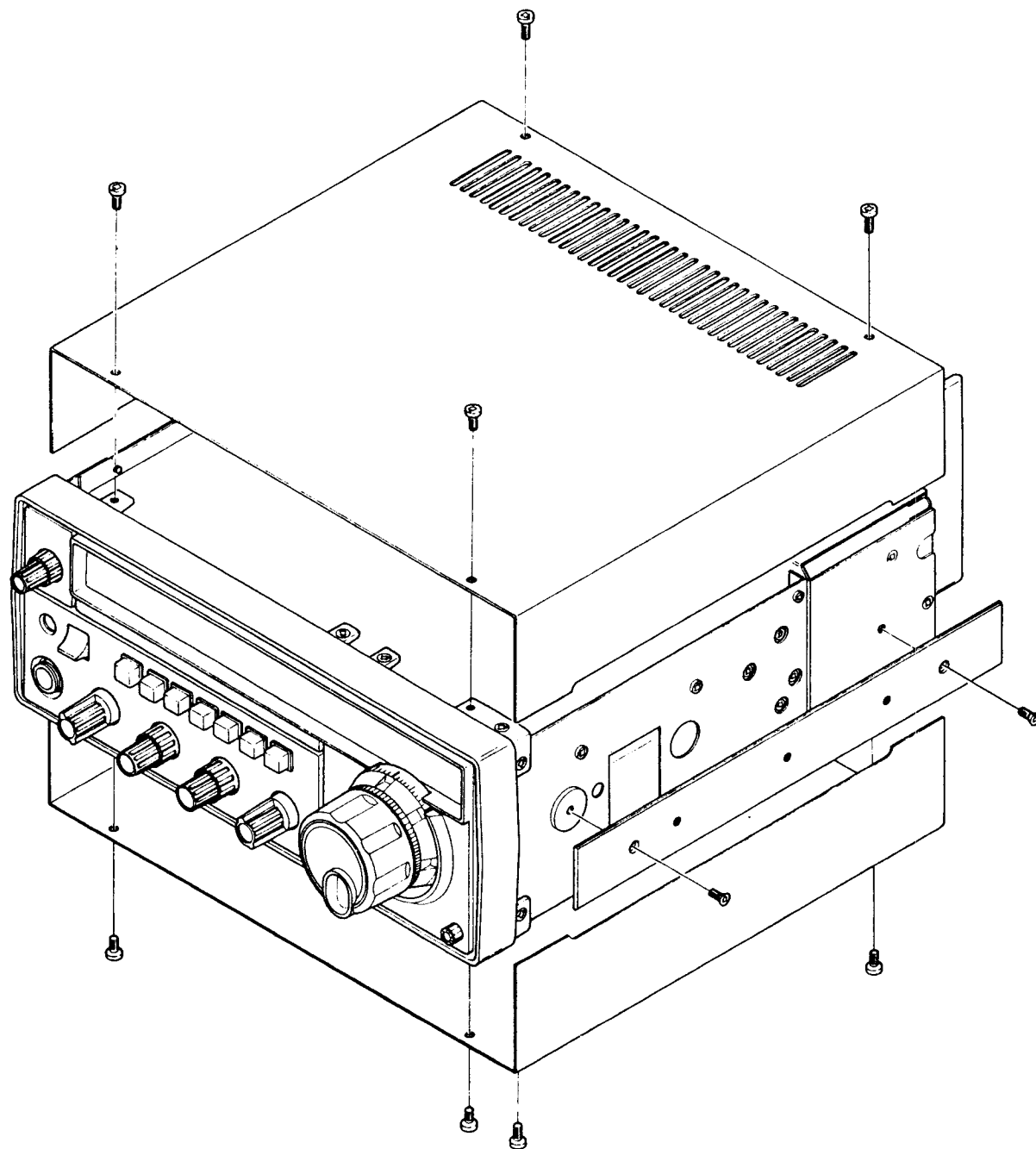

FRONT PANEL REMOVAL(A)

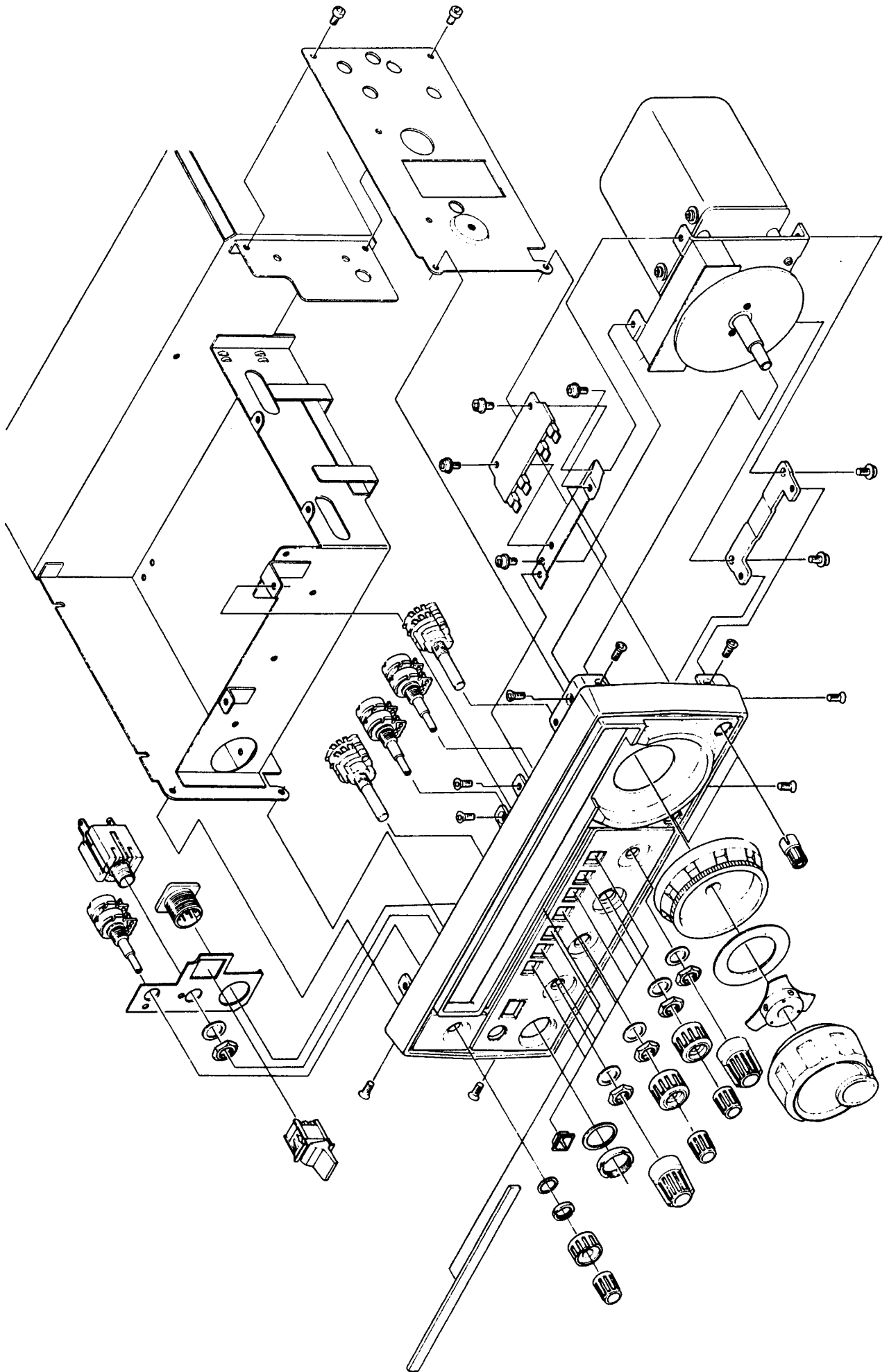

FRONT PANEL REMOVAL (B)

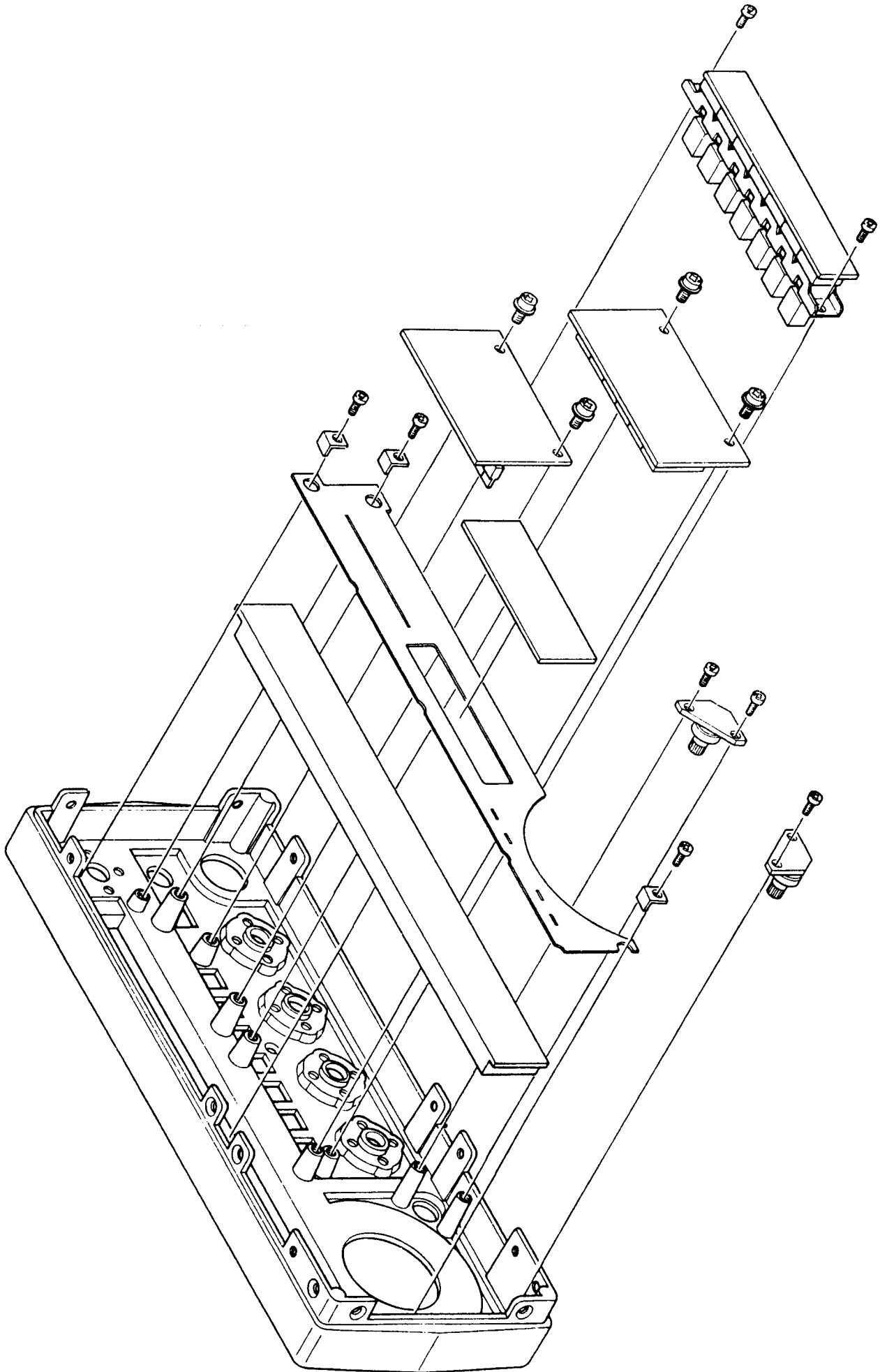

REAR PANEL REMOVAL

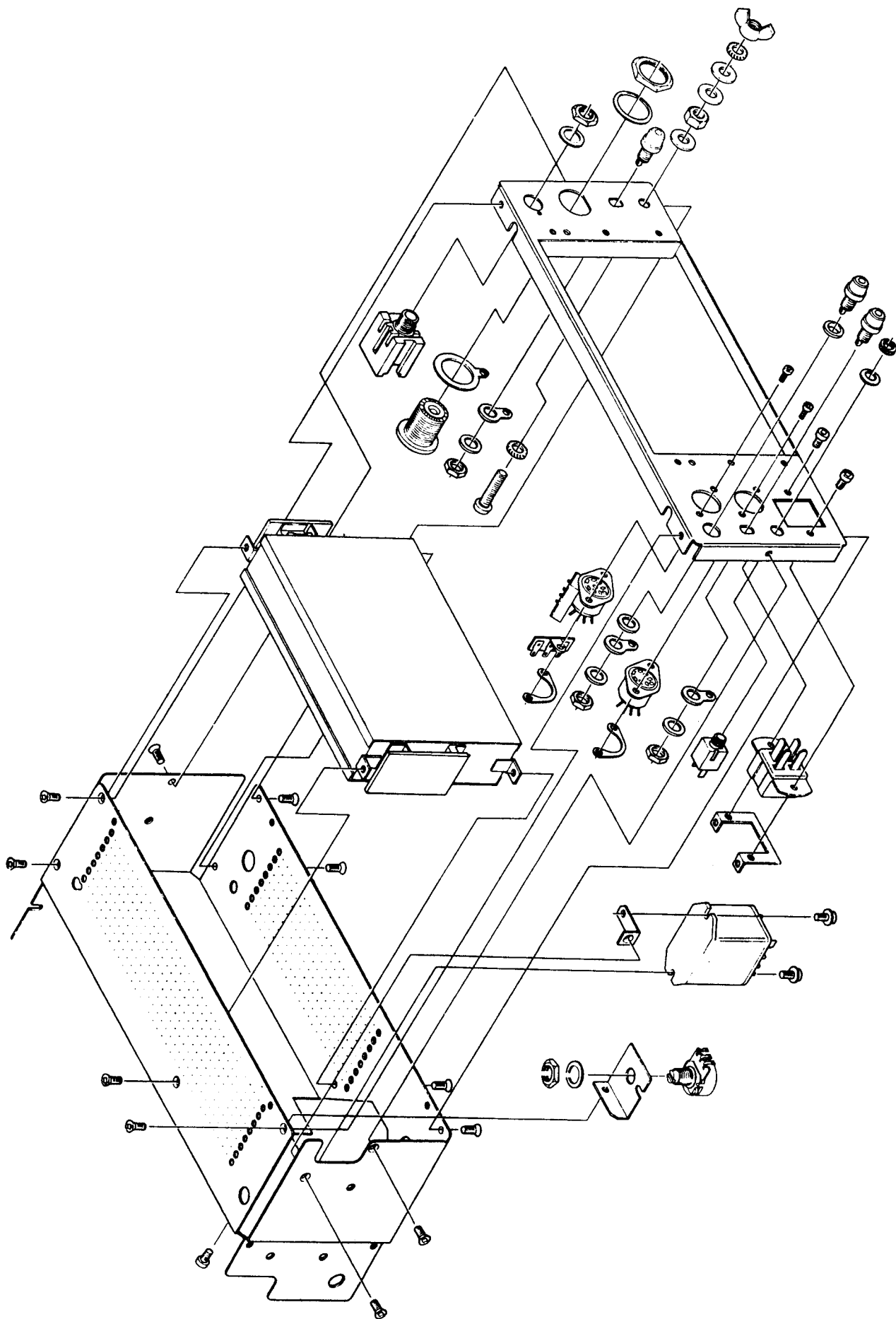

100W PA UNIT REMOVAL

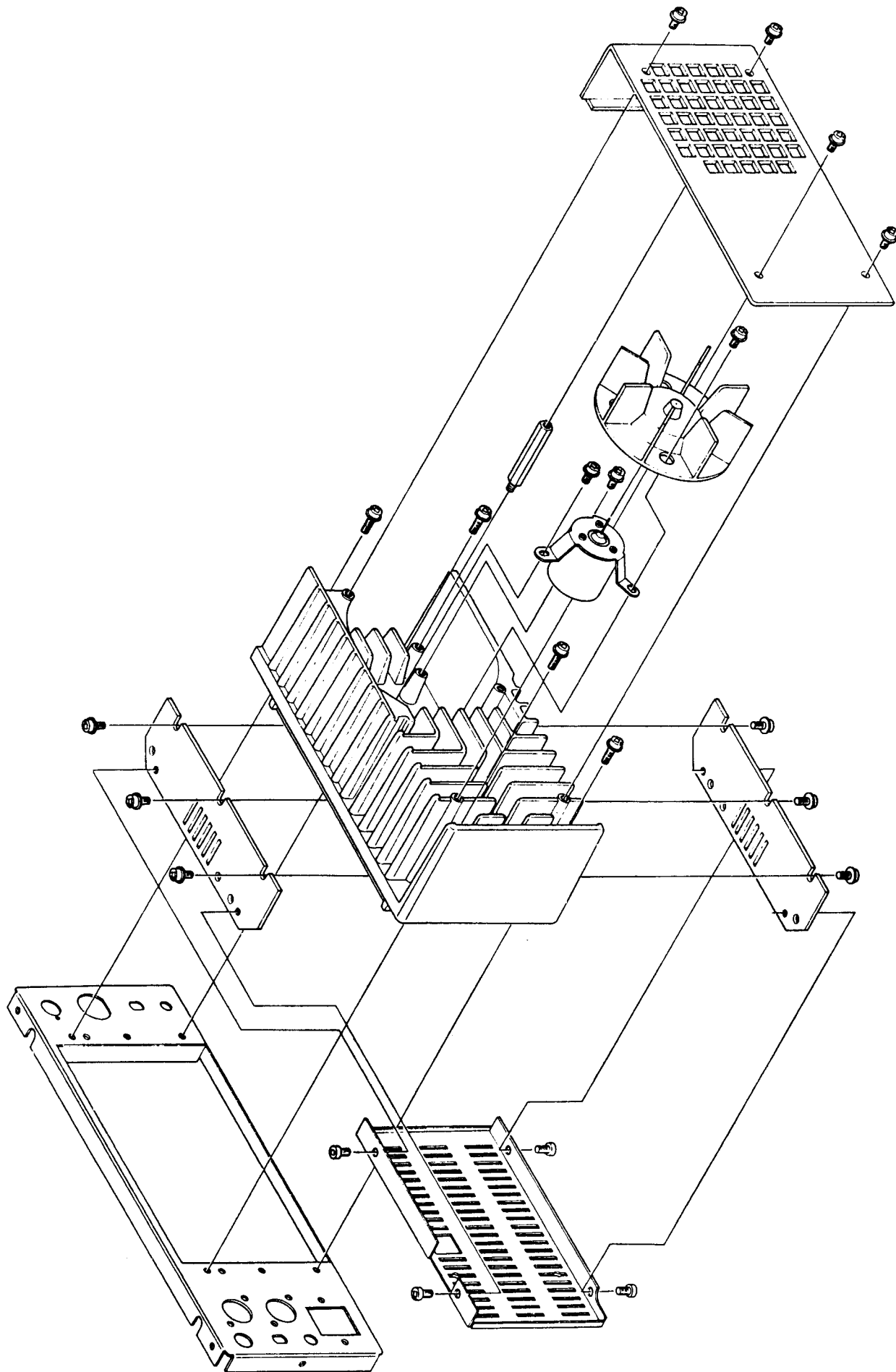

MAIN CHASSIS EXPLODED VIEW

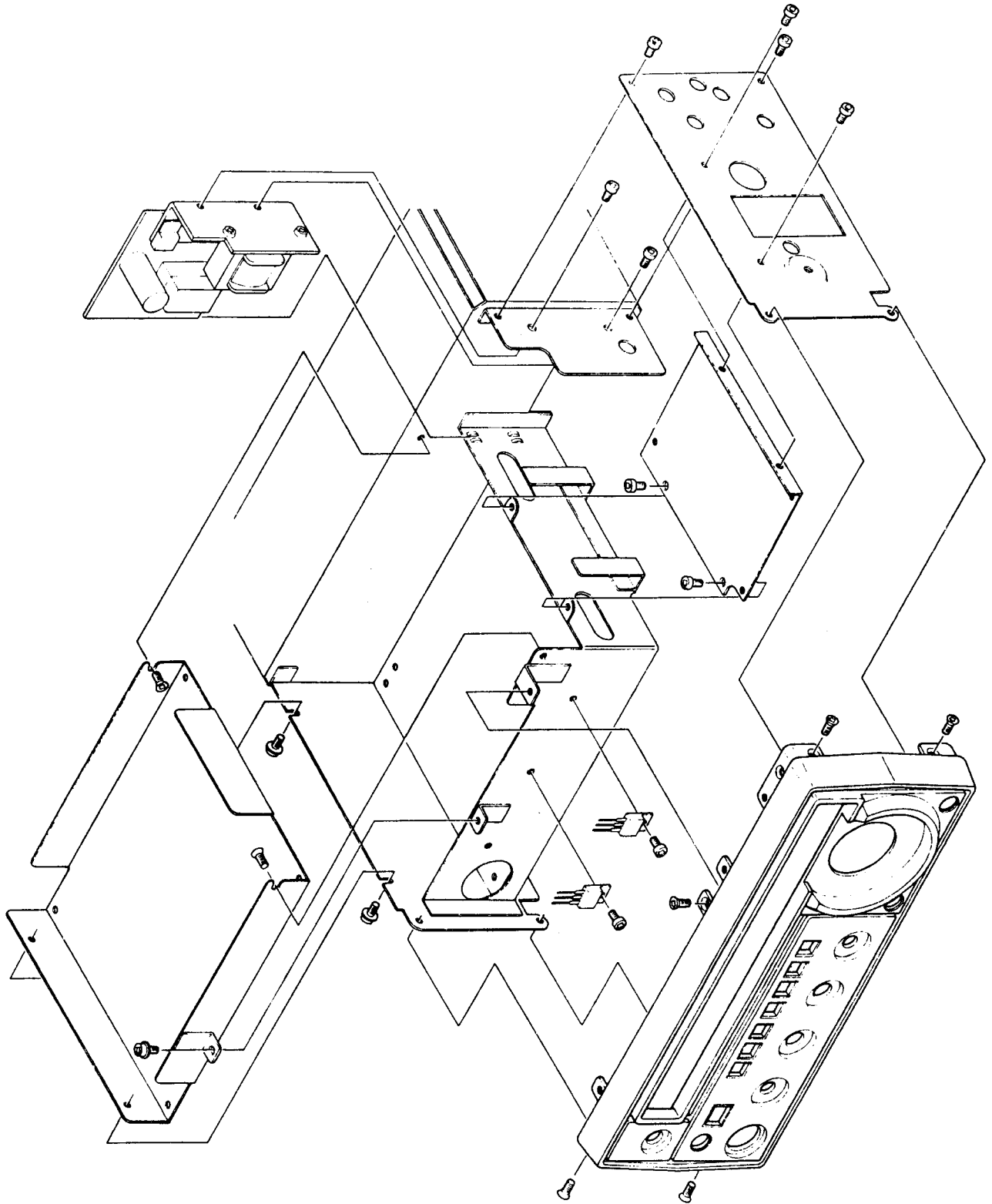

BOARD LAYOUT

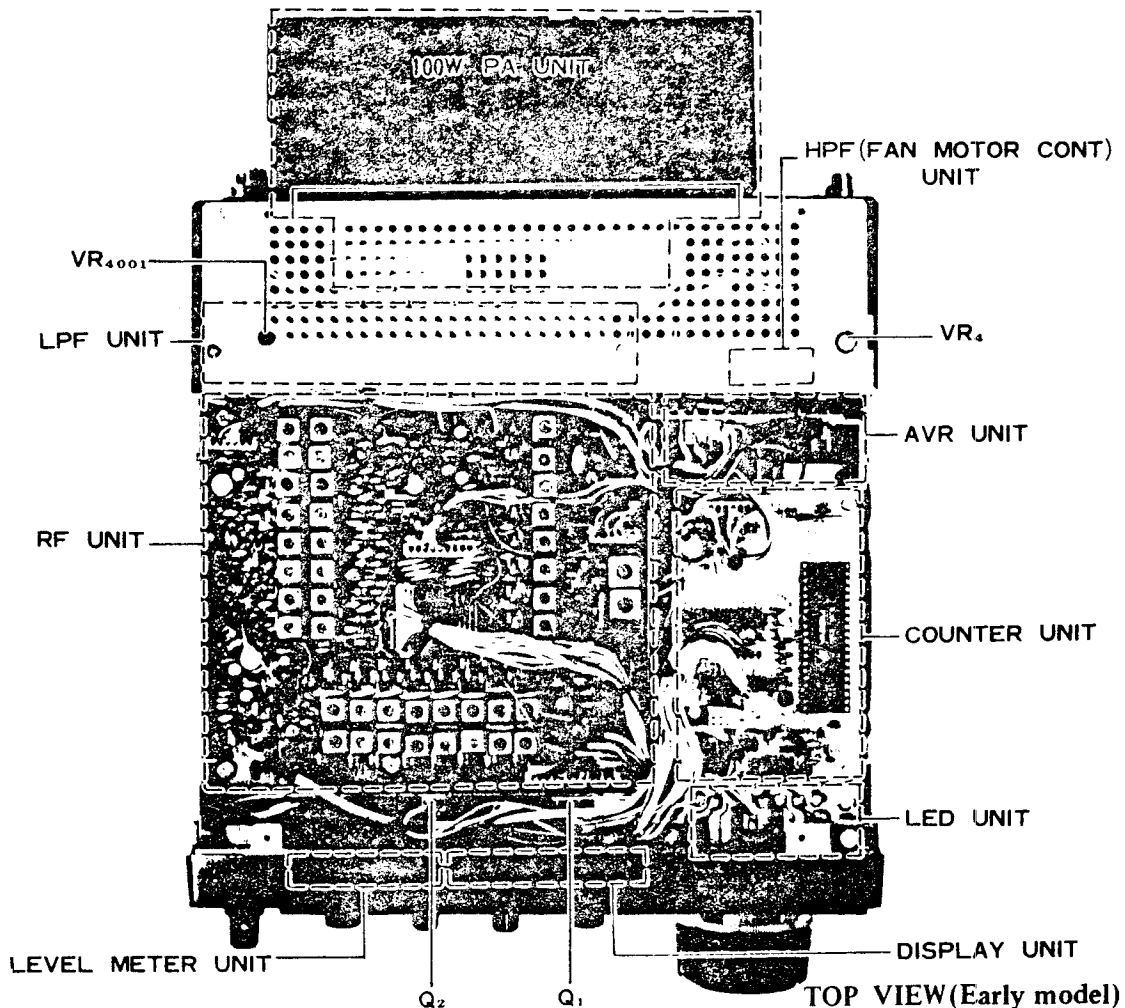

TOP VIEW (Early model)

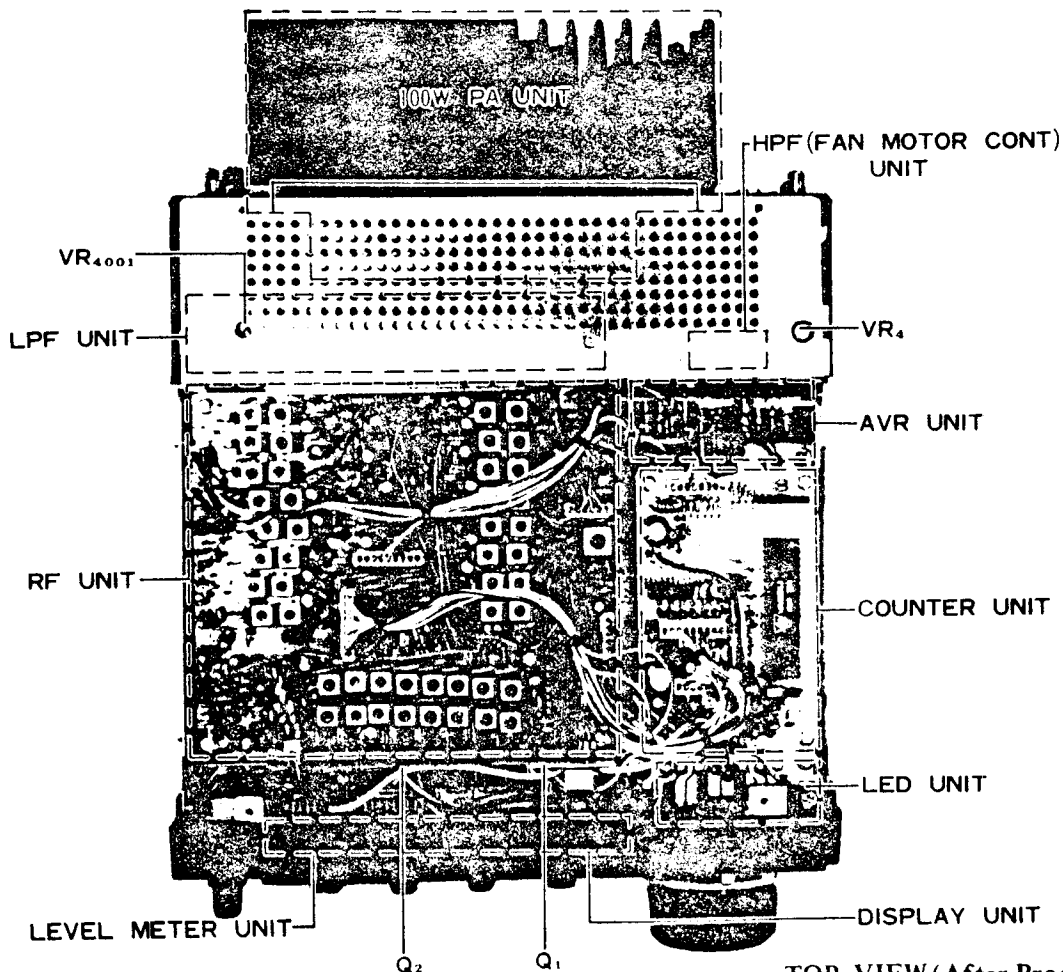

TOP VIEW (After Prod. 11)

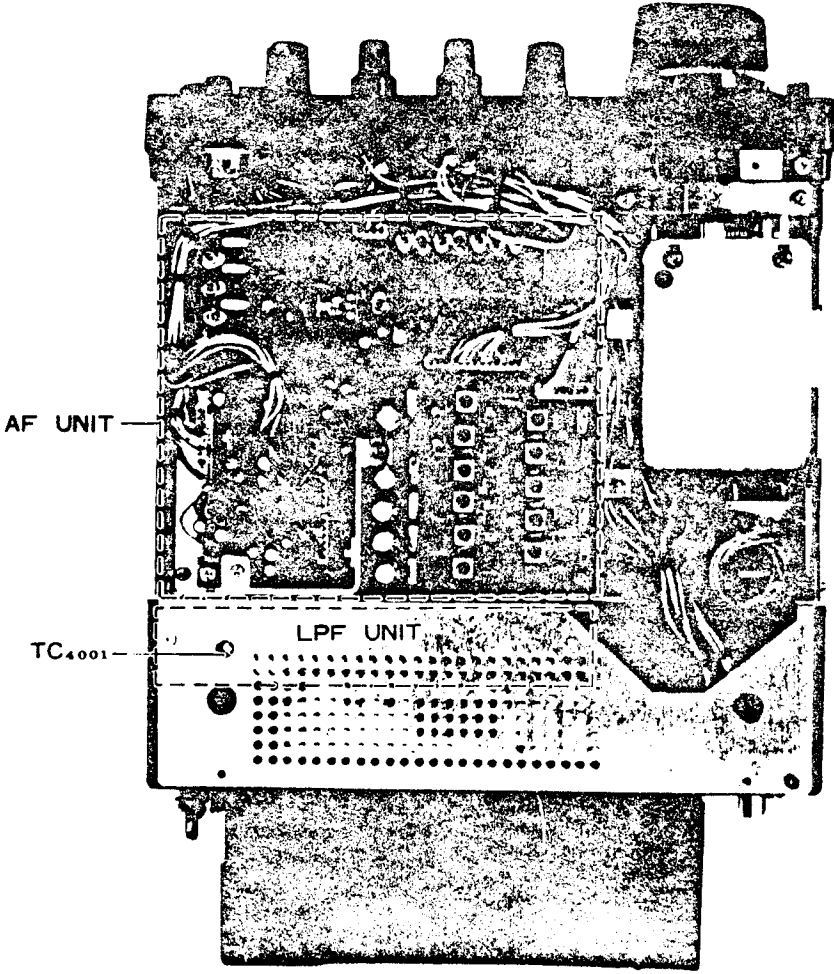
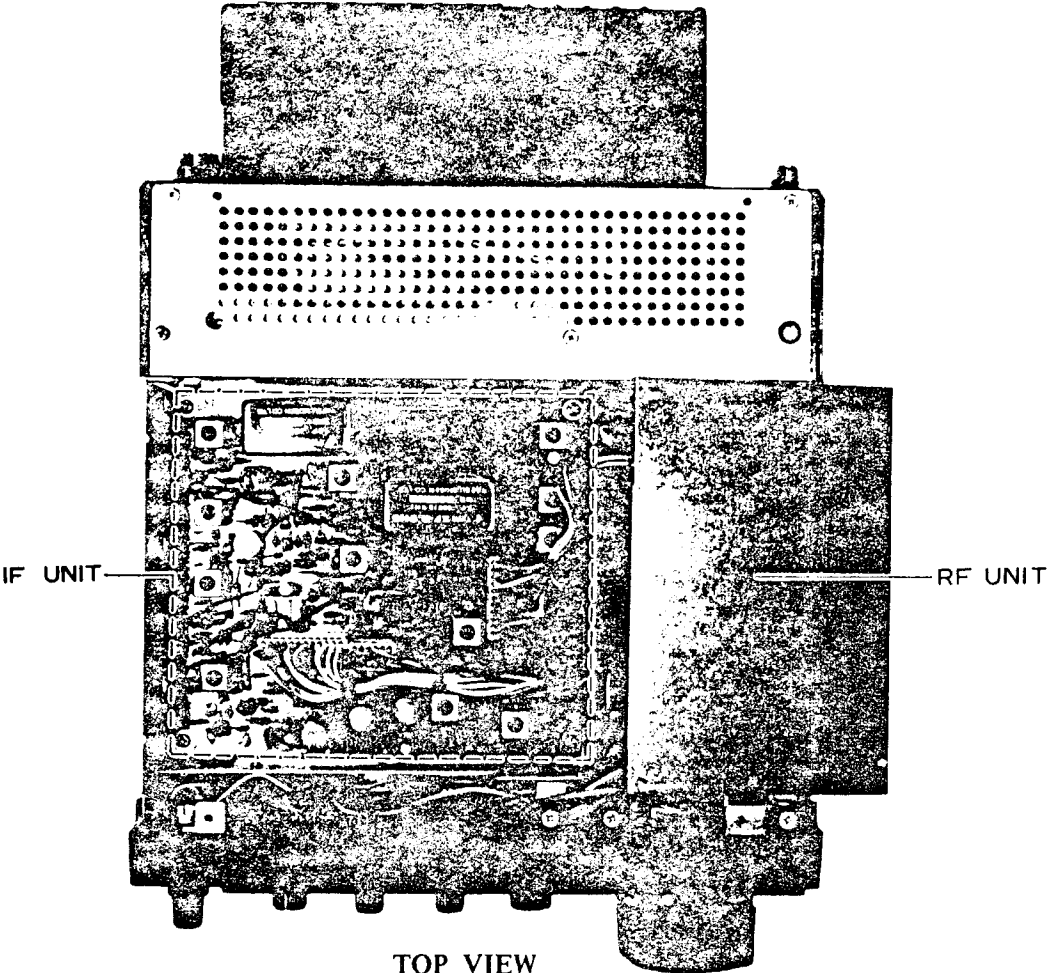

SOLDERING AND DESOLDERING TECHNIQUE

SOLDERING AND DESOLDERING TECHNIQUE ON PRINTED CIRCUIT BOARDS

The FT-707 circuit boards are tough, but mishandling during soldering can cause circuit traces to "lift." While this does no permanent damage to the board, much servicing trouble can result, because of the tendency for this lifted trace to break. A few simple precautions will keep your circuit boards in A-1 condition.

1. Use only a 12 to 30 watt chisel-tip soldering iron. Yes, some "repairmen" have been known to use small blowtorches on cards.
2. Use only a soldering iron equipped with a three-wire cord, with the tip grounded. Also acceptable is a soldering iron isolated through a transformer. An old soldering iron or gun may have 117 volts on the tip, and will certainly cause more damage than it repairs!
3. USE ONLY 60/40 ROSIN CORE SOLDER. Acid core solder should be thrown away if you find it in your radio shop!
4. Use a solder sucker and solder tape to ensure a professional repair job.
5. If you do lift a trace, don't worry! Read on to find out how to repair traces like a pro.

NOTES ON USE OF CMOS IC's:

As CMOS devices are extremely sensitive to damage from static electricity, special precautions must be observed.

In storage, use only a non-inductive sponge.

When installing a CMOS IC in a socket, or on a circuit board, be certain that the power is off. In addition, the technician should rest his hand on the chassis as the component is inserted, so as to place his hand at the same level as the chassis (better to discharge small amounts of static electricity through your fingers than through a \$5 IC!).

When soldering a CMOS IC onto a circuit board, use a low wattage iron, and be sure to ground the tip with a clip lead, if the tip is not grounded through a three-wire power cord.

INSERTION OF PARTS ON CIRCUIT BOARDS

All of the below are acceptable ways of inserting components into circuit board mounting holes.



(a) Bend leads slightly



(b) Straight-in mounting

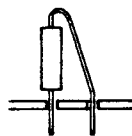

(c) Vertical mounting

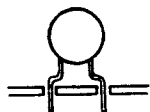

(d) Preformed disc ceramic capacitor



(e) Preformed resistor, diode, etc.

CIRCUIT TRACE REPAIR

Most of the printed circuit boards used in the FT-707 are single sided boards. However, occasionally a double-sided board is used, in situations where high shielding is required. A comparison of the two types is shown below.

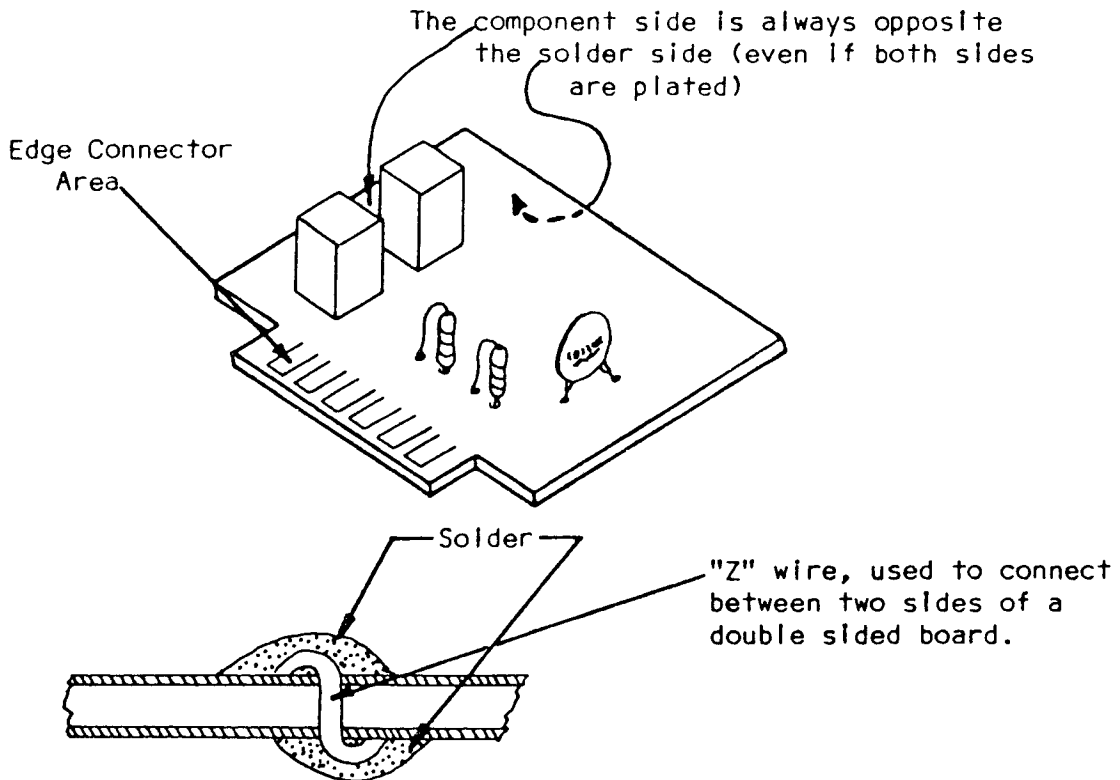
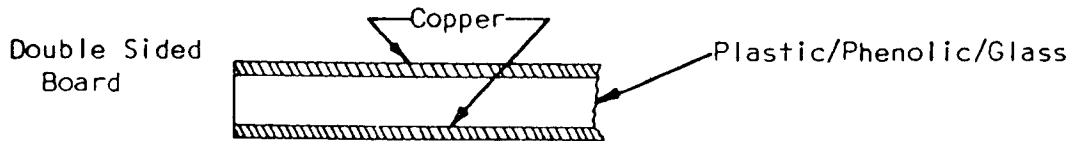
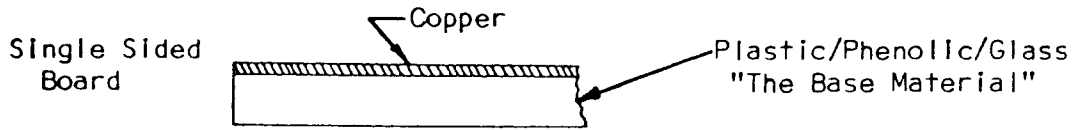

Sometimes, after the design and drafting of a board are completed, a board is produced with an error in it. Though non-technical managers sometimes suffer a stroke at hearing of this situation, it is not unheard of in engineering circles. Thus, should you encounter etch cuts and jumpers on a board, be assured that the modifications were made in the interest of securing optimum performance. Unless you consider your expertise to be superior to that of the design engineer, please leave these mods in place.

However, in service work the occasion does arise when a trace must be cut. Proceed as follows.

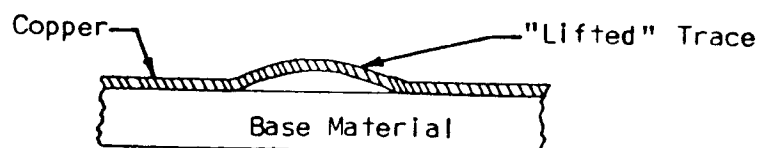
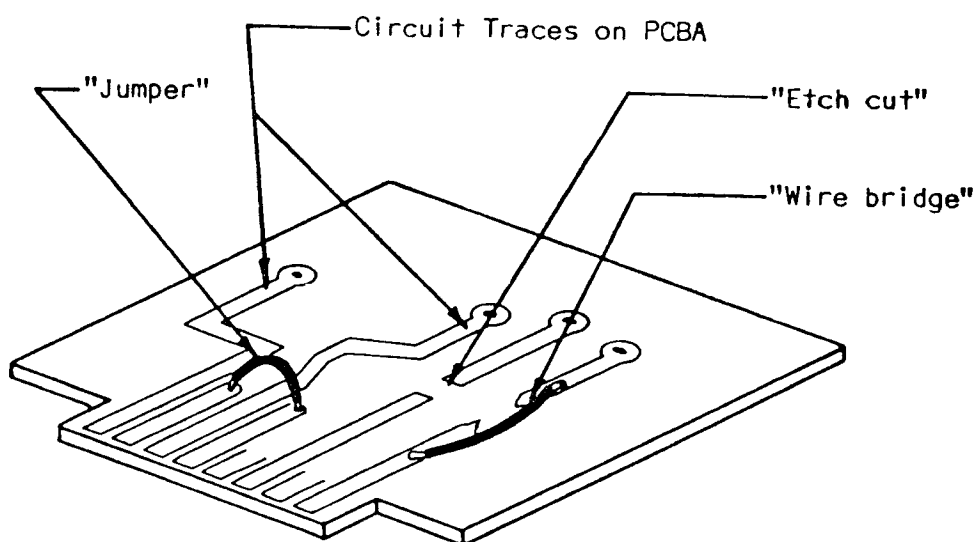

If you have previously lifted a trace, make an etch cut on each side of the lifted trace, and install a wire bridge as shown in the drawing.

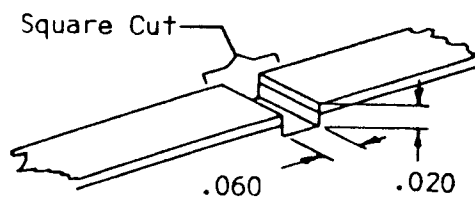

Coat Cut Area With Eastman 910

CW FILTER INSTALLATION

- (1) Refer to Figure 3-1, and remove the top cover of the transceiver.
- (2) Refer to Figure 3-2, and remove the three screws marked "A" in the drawing. Remove the RF Unit.
- (3) Refer to Figure 3-3, and remove the four screws marked "B" restraining the IF Unit. Remove the three connectors of the IF Unit, and remove the board from the transceiver.
- (4) Mount the CW filter in the position shown in Figure 3-4. Cut the two jumpers shown in the drawing when the CW filter is installed.
- (5) Replace the IF Unit and RF Unit into the transceiver. Replace the top cover of the transceiver. Installation is now complete. The CW filter will be selected when the MODE switch is set to CW-N, while the SSB filter will be selected when the MODE switch is set to CW-W.

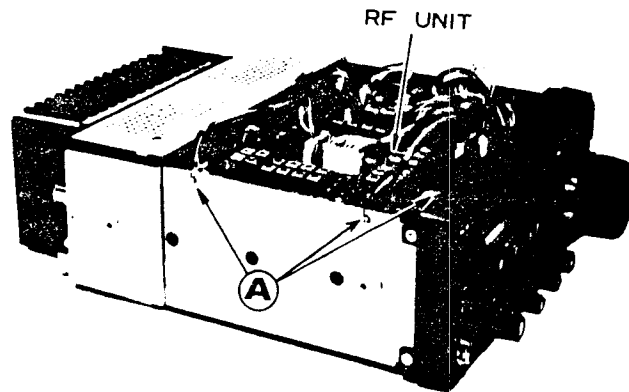

Fig. 2

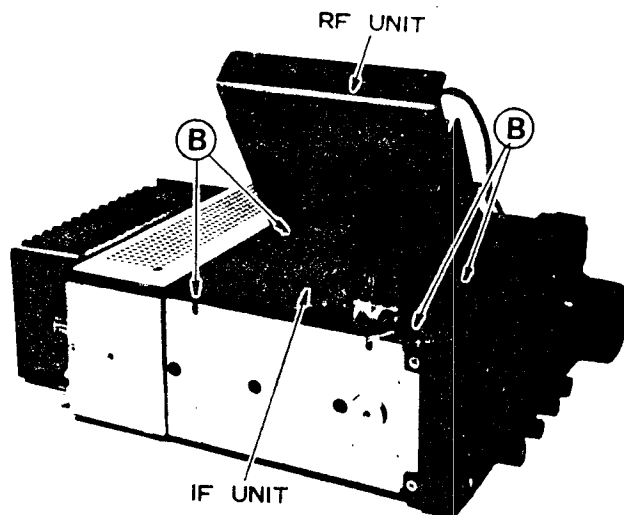

Fig. 3-3

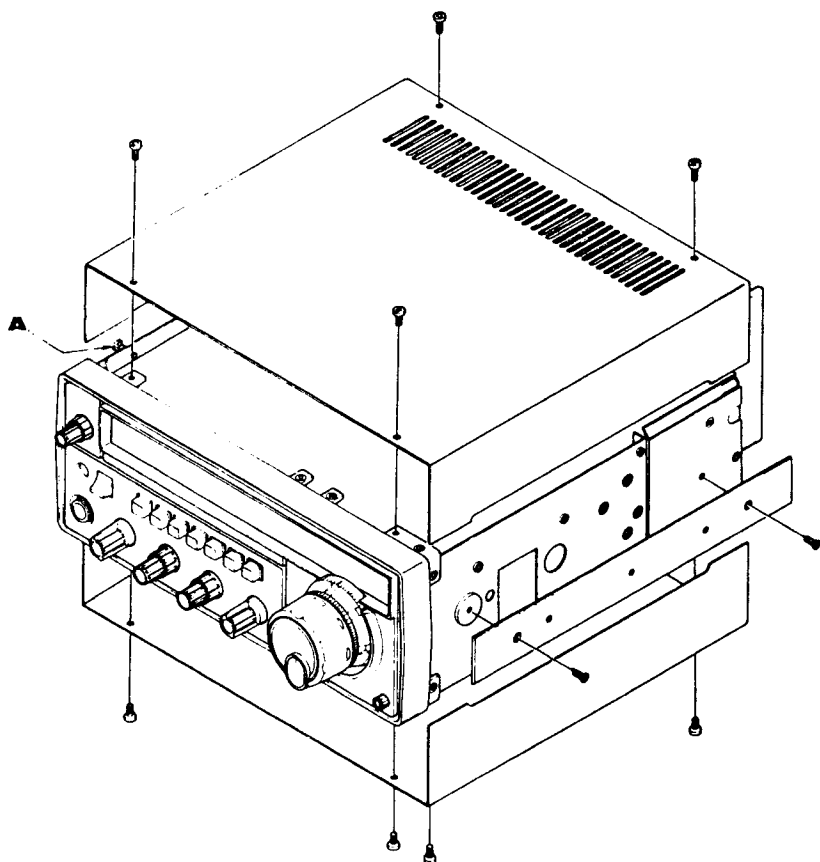

Fig. 3-1

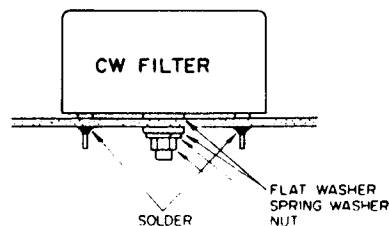
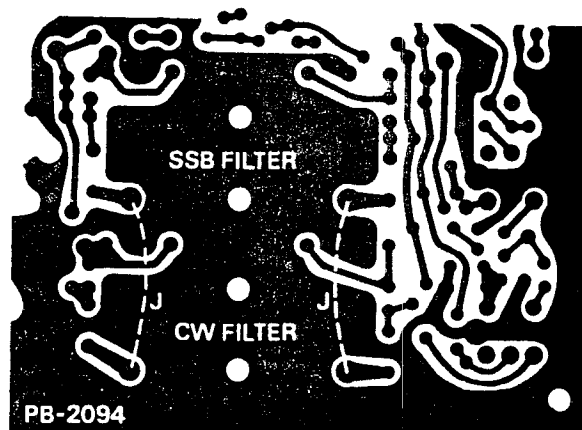

Fig. 3-4

FIX (CRYSTAL CONTROLLED) OPERATION

Fixed channel operation is possible by using crystals installed in the AF UNIT. The VFO/FIX switch must be placed in the FIX position. There is only one crystal controlled channel available per band with the FT-707. Crystals are optional. (except 30m band)

Crystals must fall within the specifications shown in Table 3-1, and must fall within the operating range 5.5–5.0 MHz. Frequency calculation for the crystals is made from the formula

$$F_x = F_1 - F_0$$

where F_x is the crystal frequency,

F_1 is a constant derived from Table 3-2.

and F_0 is the operating frequency.

For example, let us say it is desired to operate on 7199 kHz LSB. Referring to Table 3-2, we see that for 40 meter LSB, F_1 is 12498.5 kHz. Subtracting F_0 (7199 kHz) from F_1 (12498.5 kHz) yields 5299.5 kHz, the crystal frequency (F_x).

For operation on 21420 kHz USB, compute the crystal frequency as follows:

$$F_x = 26498.5 - 21420 = 5078.5 \text{ kHz.}$$

Inspection of the values of F_1 in Table 3-2 will reveal that the 7199 kHz crystal for LSB will work on 14202 kHz, 21202 kHz, etc. Of course, LSB is not normally used on these bands. If the operator switches to USB, the operating frequency will be moved 3 kHz (in this case, to 14199 kHz, 21199 kHz, etc.). If the move is made from LSB to CW, the frequency will move 2.2 kHz down. (to 7196.8, 14199.8, etc.)

To net the crystal on frequency when using the FT-707, use the transceiver digital display to adjust the trimmers for each crystal (TC_{3005} for 80 m, TC_{3006} for 40 m, etc.). Be sure that the CLAR switch is turned off during trimmer adjustment.

The optional crystals are available from your Yaesu dealer.

| | |
|-------------|---------|
| Holder | HC-25/U |
| Load C | 30pF |
| Effective R | 25Ω |
| Drive level | 5mW |

Table 3-1

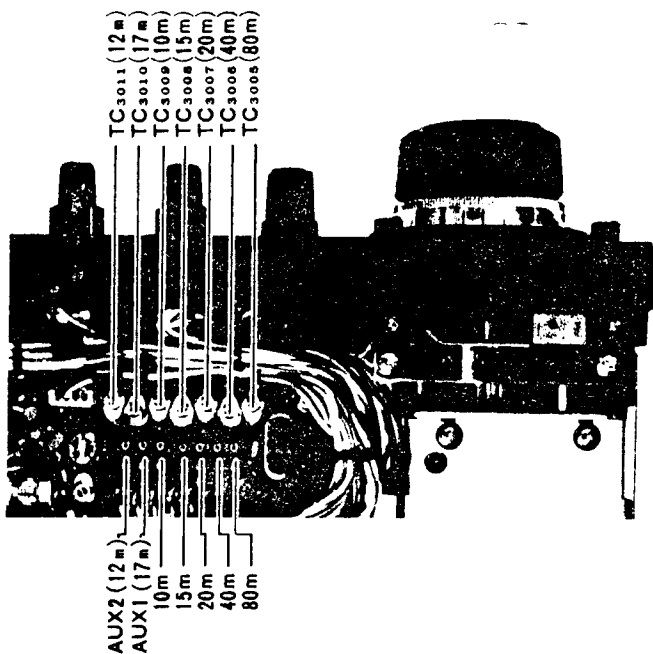

| BAND \ MODE | USB MHz | LSB MHz | AM/CW MHz |
|-------------|---------|---------|-----------|
| 80m | 8995.5 | 8998.5 | 8996.3 |
| 40m | 12495.5 | 12498.5 | 12496.3 |
| * 30m | 15498.5 | 15501.5 | 15499.3 |
| 20m | 19498.5 | 19501.5 | 19499.3 |
| 17m | 23498.5 | 23501.5 | 23501.5 |
| 15m | 26498.5 | 26501.5 | 26499.3 |
| 12m | 29998.5 | 30001.5 | 29999.3 |
| 10mA | 33498.5 | 33501.5 | 33499.3 |
| 10mB | 33998.5 | 34001.5 | 33999.3 |
| 10mC | 34498.5 | 34501.5 | 34499.3 |
| 10mD | 34998.5 | 35001.5 | 34999.3 |

F_1 (kHz)
Table 3-2

TX IMD DISTORTION IMPROVEMENT

In some FT-707 transceivers with serial numbers below XX10999, a slight audible distortion occurs on modulation. The problem is caused by a pair of driver transistors, Q₄₂₀₂ and Q₄₂₀₃ in the 100W PA unit, in which low Hfe transistors are used. If these transistors are marked with an "R" on the package, as shown in the figure below, the following modification can be adopted.

Install two 1/2W 1 ohm resistors parallel to each other, and in series with D₄₂₀₂ and D₄₂₀₃ in the 100W PA Unit.

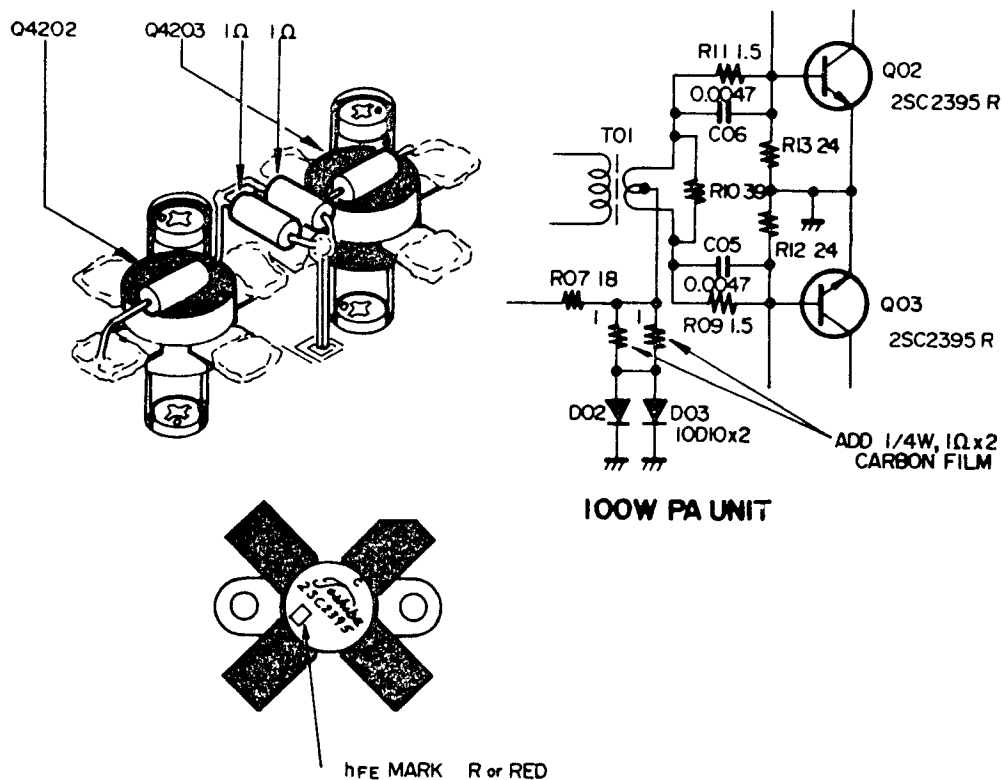

hFE CLASSIFICATION

| hFE | | MARK | COLOR |
|-----|-----|------|-------------|
| MIN | MAX | | |
| 20 | 65 | R | RED |
| 55 | 95 | O | RED & BLACK |
| 85 | 150 | Y | BLACK |

Figure 3-7

MARKER MODIFICATION

FT-707 units with serial numbers below XX099999 may be modified to increase the marker level, making it easier to zero in on the marker signal on crowded bands.

Replace C₃₁₃₇, a 3pF SL ceramic capacitor with a 6pF SL ceramic capacitor.

PREMIX MODIFICATION

To increase the local injection level to the mixer Q₁₀₀₈ on the RF unit, so as to improve RX performance, perform the following modification.

Connect a 470pF dipped mica capacitor, as shown in the figure below, on the RF unit, PB-2093.

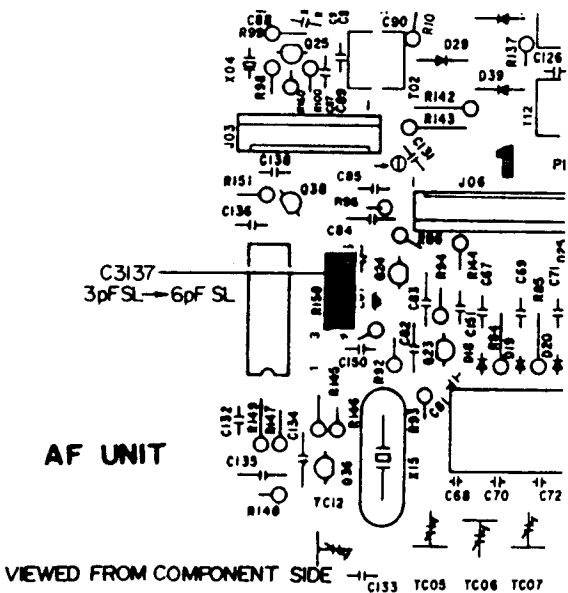

RECEIVER INPUT CIRCUIT MODIFICATION

This modification will improve the intermodulation distortion performance of the receivers in transceivers with serial numbers below XX079999 and will ensure attenuation of the high-pass filter below 2 MHz.

Modification Procedure

Replace R_{1013} , R_{1014} , R_{1016} and $R_{1018} - R_{1022}$ with 220 ohms. (See Figure 3-10)

Replace R_{1002} and R_{1008} with 270 ohms. (See Figure 3-10)

Replace C_{4807} and C_{4809} with 1500pF. (See Figure 3-11)

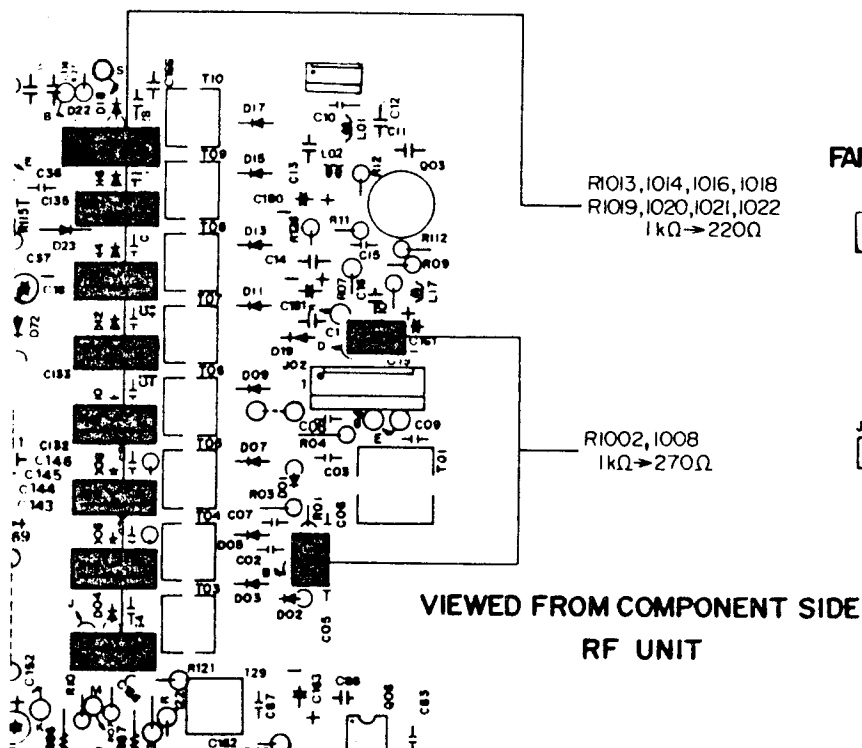

Figure 3-10

FAN MOTOR CONTROL UNIT

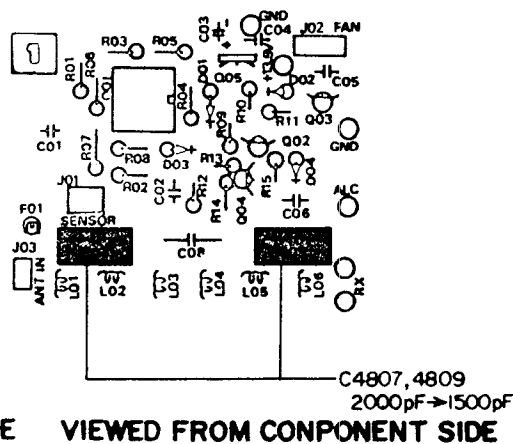

Figure 3-11

WARC TX MODIFICATION

To enable the FT-707 to transmit on the newly allocated amateur bands, the following modifications are required.

Refer to Figures below. Locate the RF UNIT, and remove diodes D₂₁, D₇₁ and D₇₂.

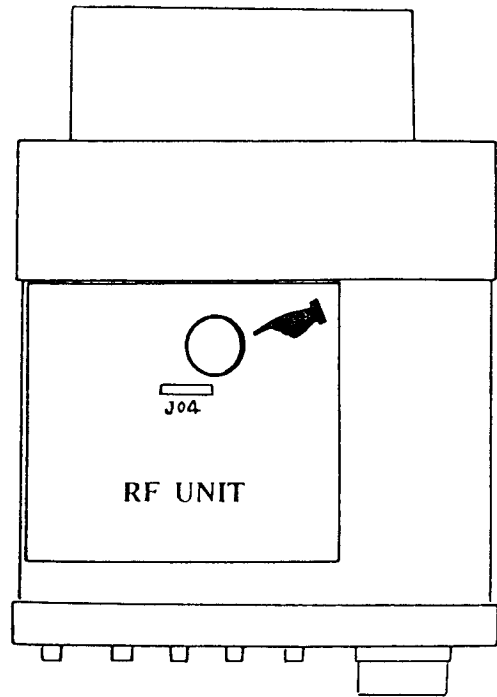

Figure 3-12

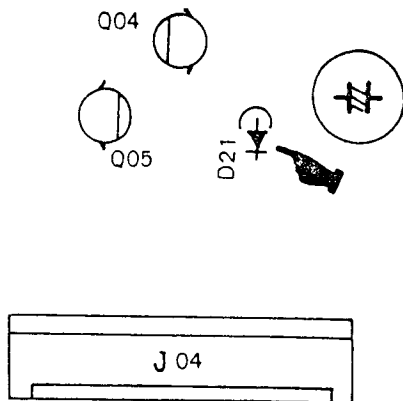
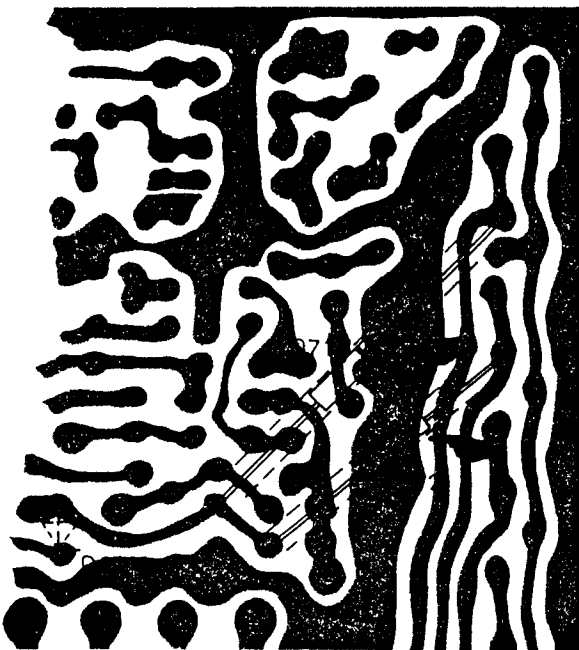
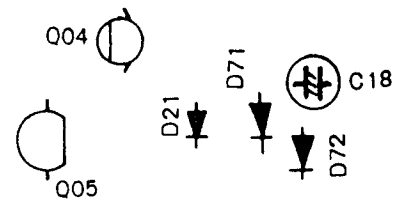

Figure 3-13A



Serial Number
029999 & Down

Figure 3-13B



Serial Number
030001-039999

Figure 3-14

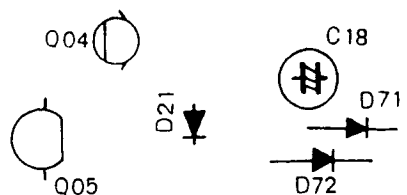

Serial Number
040001 & Up

Figure 3-15

COUNTER UNIT

The carrier points for USB, LSB and CW are preset as follows:

- USB = 91.011.0
- LSB = 91.014.0
- CW or AM = 91.011.7

If for some reason, you wish to change the carrier points for LSB and USB, the counter preset frequency can be changed to within ± 200 Hz of the desired frequency. Please refer to the Frequency Counter Preset Diode Connection Chart for details. This adjustment is carried out by connecting jumper wires on the counter unit.

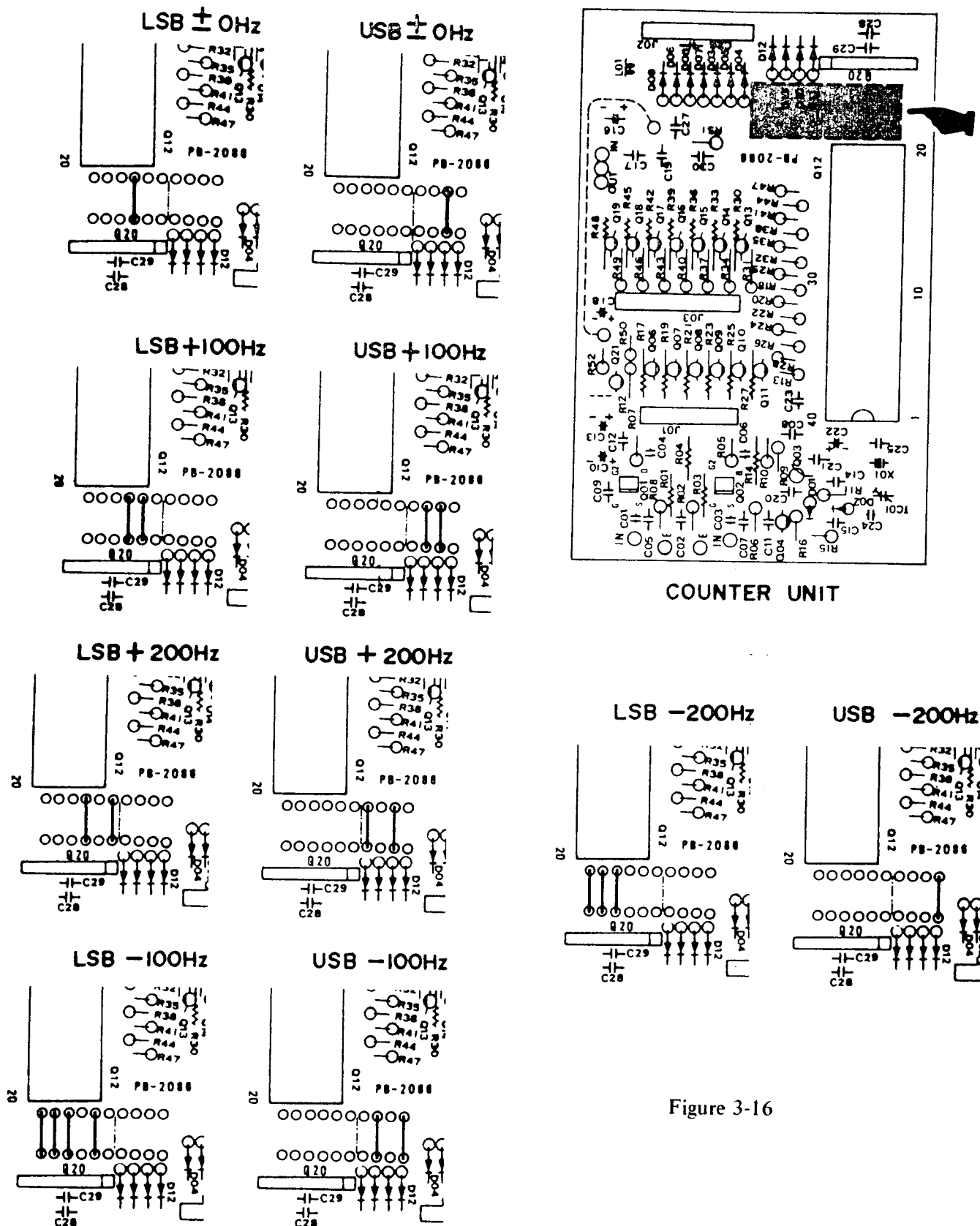

COUNTER UNIT

Figure 3-16

MEMO

MAINTENANCE AND ALIGNMENT

This transceiver has been carefully aligned and tested at the factory. With normal use, it should not require other than the usual attention given to electronic equipment.

Service or replacement of a major component may require substantial adjustment. Under no circumstances, though, should realignment be attempted unless the operation of the transceiver is fully understood, the malfunction has been carefully analyzed, and the fault has definitely been traced to misalignment. Sudden difficulties are almost always caused by component failure, rather than misalignment.

Service must be performed only by experienced personnel, using the proper test equipment.

EQUIPMENT REQUIRED

- (1) RF Signal Generator: Hewlett-Packard Model 606A or equivalent, with one volt output at 50 ohms, and frequency coverage to 30 MHz.
- (2) Vacuum Tube Voltmeter (VTVM): Hewlett-Packard Model 410B or equivalent, with an RF probe good to 40 MHz.
- (3) Dummy Load: Yaesu Model YP-150Z or equivalent, with 50 ohm non-reactive load impedance, rated to 150 watts average power.
- (4) AF Signal Generator: Hewlett-Packard Model 200 AB or equivalent.
- (5) A general coverage receiver covering 3 to 30 MHz, with a 100 kHz crystal calibrator.
- (6) Frequency Counter: Yaesu Model YC-500 or equivalent, with resolution to 0.01 kHz and frequency coverage to 30 MHz.
- (7) Oscilloscope: Hewlett-Packard Model 1740A or equivalent.

NOTE REGARDING MEASUREMENT LEVELS

Where decibel levels are quoted in the following section (e.g. "Apply a 90 dB signal..."), the reference used is 0 dB = 1 μ V. At 50 ohms, this level is equivalent to -107 dBm.

- d) Now recheck the previous test using your voice to activate the VOX. Do not advance the VOX control nor VR₃₀₀₃ farther than necessary for proper performance, as confusing results will be obtained if these controls are advanced too far.

**VOX ADJUSTMENT
(VOX GAIN/ANTITRIP SETTING)**

- a) Set up the transceiver for reception on any band. Set the AF GAIN control for a comfortable listening level. The MODE switch should be set to LSB or USB.
- b) Without closing the PTT switch, hold the microphone near your mouth, and speak in a normal voice into the microphone. Advance the VOX control until your voice activates the transmitter.
- c) Without closing the PTT switch, hold the microphone near the speaker output. If the speaker audio causes the VOX to trip, adjust VR₃₀₀₃ (AF Unit) so that the speaker output does not activate the transmitter.

S-METER ALIGNMENT

- a) Set the BAND switch to 20, the main tuning dial to 14.250 MHz, and the RF GAIN control fully clockwise.
- b) Connect a signal generator to the antenna jack, and tune its output to the receiver frequency.
- c) With no signal applied from the signal generator, adjust VR₂₀₀₃ (IF Unit) so that none of the LEDs on the level meter are illuminated. Do not go beyond the threshold point required for complete darkening of the entire line of LEDs.
- d) Now apply a 90 dB signal from the signal generator, and adjust VR₂₀₀₄ (IF Unit) so that all 10 LEDs are illuminated.

AF UNIT ALIGNMENT POINTS

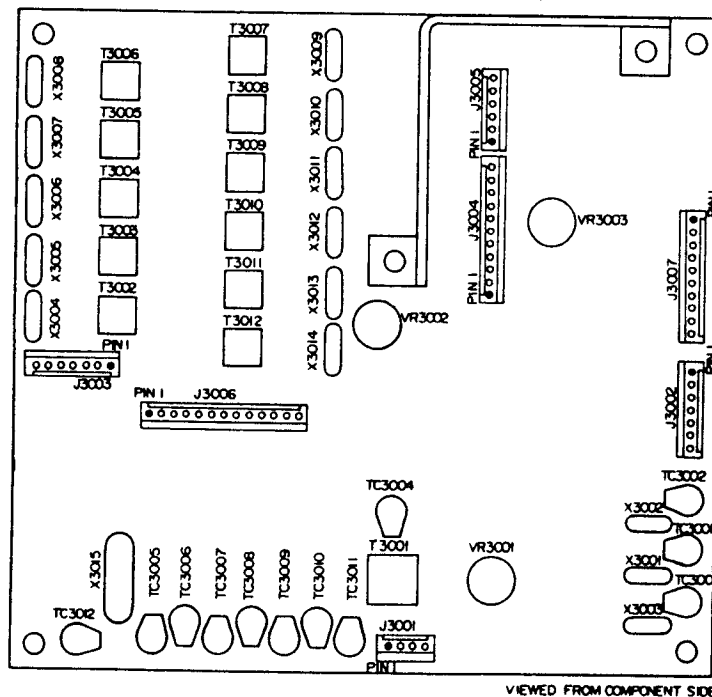

AF UNIT

CW SIDETONE LEVEL ADJUSTMENT

- a) Adjust VR₃₀₀₂, located on the AF Unit, for the desired CW sidetone level.

- b) Set the audio oscillator frequency to 1500 Hz, and its output level to 5 mV. Close the MOX switch, and advance the MIC control to achieve an output power of 60 watts as indicated on the dummy load/wattmeter.

MARKER ALIGNMENT

- a) Set the BAND switch to 30, and the MODE switch to AM. Adjust the AF GAIN control for a comfortable listening volume on the standard frequency station.
- b) Push the MARK switch, and listen for evidence of a beat between the marker signal and the standard frequency station. If there is any beat note, adjust TC₃₀₁₂ (AF Unit) for a zero beat between the calibrator and the standard frequency station.

- c) Without changing any level settings, set the audio oscillator output frequency to 300 Hz, and adjust TC₃₀₀₁ (AF Unit) for a power output of 15 watts, as indicated on the dummy load/wattmeter.
- d) Set the MODE switch to USB, and repeat the above procedure on USB.
- e) Switch back and forth between USB and LSB. If there is any difference in the pitch of the background receiver noise, adjust the WIDTH control presetting as described below.

CARRIER POINT ALIGNMENT

- a) Set the BAND switch to 20, the main dial to 14.250 MHz, and the MODE switch to LSB. Connect an audio oscillator to the microphone input, pin 8 of the mic jack.

IF WIDTH ALIGNMENT

- a) Set the front panel WIDTH control to the 12 o'clock position. Switch between LSB and USB, and adjust VR₂₀₀₂ (IF Unit) so that the background noise of the receiver is identical on both modes.

IF UNIT ALIGNMENT POINTS

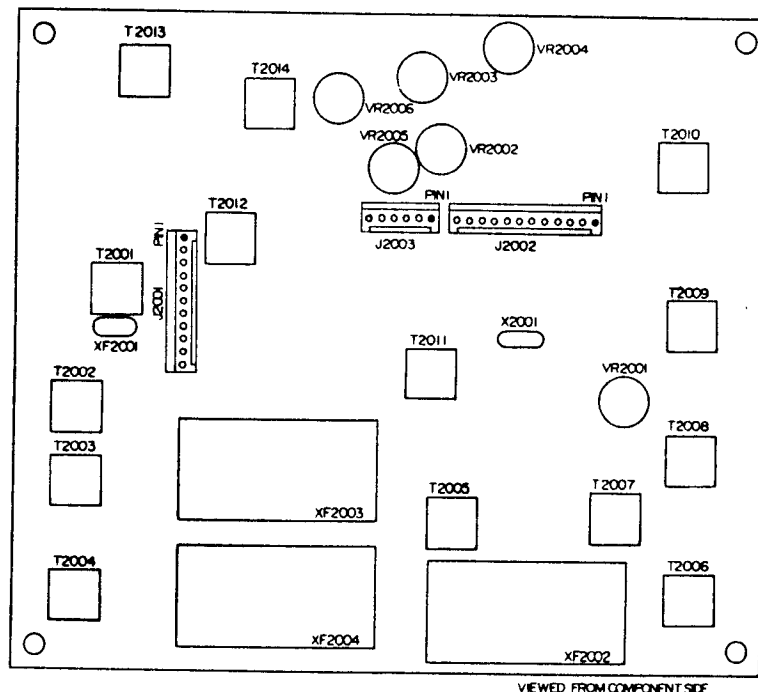

IF UNIT

CARRIER BALANCE ADJUSTMENT

- a) Set the BAND switch to 20, the main dial to 14.250 MHz, and the MODE switch to LSB. Set the MIC control fully counterclockwise, and remove all oscillator or other modulation sources from the mic input.
- b) With an external receiver tuned to the FT-707 transmitting frequency, adjust VR₃₀₀₁ and TC₃₀₀₄ (AF Unit) for minimum signal indication on the external receiver with the MOX switch of the FT-707 closed.
- c) Now set the MODE switch to USB, and check the results. Adjust VR₃₀₀₁ and TC₃₀₀₄ again, if needed, to assure optimum carrier nulling. Then check the LSB results again. Several passes may be necessary.

CW CARRIER POINT ALIGNMENT

- a) Set the BAND switch to 20, the main dial to 14.250 MHz, and the MODE switch to CW.
- b) Lightly couple the probe of a precision frequency counter to the coax cable between the antenna jack and the dummy load. Close the PTT switch, and close the key. Adjust TC₃₀₀₃ (AF Unit) so that the frequency on the counter is exactly the same as that on the digital display.

VFO UNIT

The VFO is very critical in its adjustment. As well, this is not an area which should require servicing. For this reason, we recommend that all cases of VFO repair be referred to a Yaesu service center. Cases of VFO instability or drift can almost always be traced to a fault elsewhere in the system, such as instability in a supply voltage, etc.

From a service standpoint, however, two components are of interest:

- TC₄₃₀₁ is the band set trimmer.
- TC₄₃₀₂ is the VFO output level adjustment trimmer.

To confirm proper VFO injection, connect the RF probe of the VTVM to TP₁₀₀₃ (RF Unit). Adjust TC₄₃₀₂ for a reading of 50 mV on the VTVM.

LOCAL OSCILLATOR CIRCUITS

(1) Premix Bandpass Filter Adjustment

- a) Connect a jumper between TP₁₀₀₂ and TP₁₀₀₃ (RF Unit). Connect a sweep generator at that point. Connect the oscilloscope (through a detector) to TP₁₀₀₁ (RF Unit).
- b) Refer to Table 3-3, and apply sweep on each band shown at the proper frequency. Adjust the cores of the transformers shown in Table 3-3 for the pattern shown in Figure 3-17.
- c) Now connect the RF probe of the VTVM to TP₁₀₀₁. Refer to Table 3-4, and adjust the cores shown for each band for a reading of 700 mV on each band.

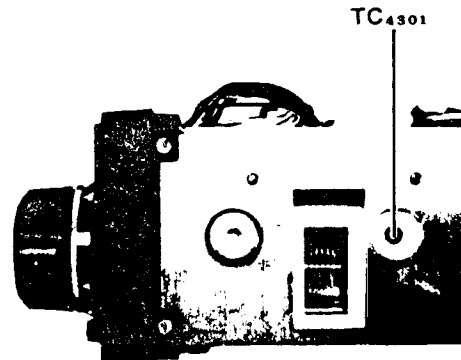
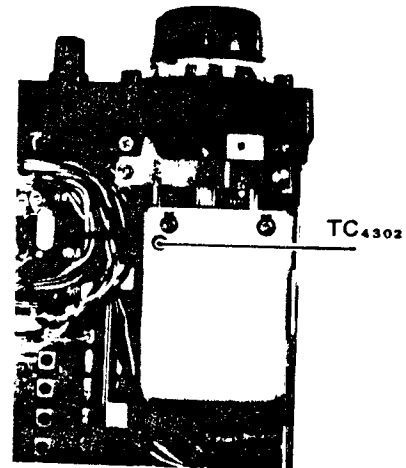

VFO

| BAND | TRANSFORMER | PASS BAND MHz |
|------|-------------------------------------|---------------|
| 80m | T ₁₀₃₂ T ₁₀₃₁ | 12.5-13.0 |
| 40m | T ₁₀₃₄ T ₁₀₃₅ | 16.0-16.5 |
| 30m | T ₁₀₃₀ T ₁₀₃₁ | 19.0-19.5 |
| 20m | T ₁₀₃₆ T ₁₀₃₇ | 23.0-23.5 |
| 17m | T ₁₀₄₂ T ₁₀₄₃ | 27.0-27.5 |
| 15m | T ₁₀₃₈ T ₁₀₃₉ | 30.0-30.5 |
| 12m | T ₁₀₄₄ T ₁₀₄₅ | 33.5-34 |
| 10m | T ₁₀₄₀ T ₁₀₄₁ | 37-39 |

Table 3-3

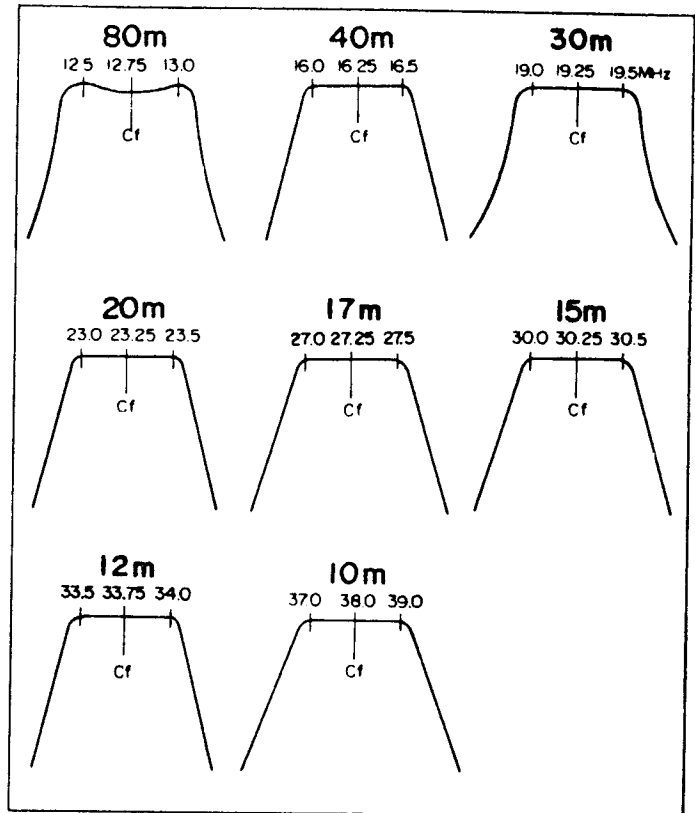
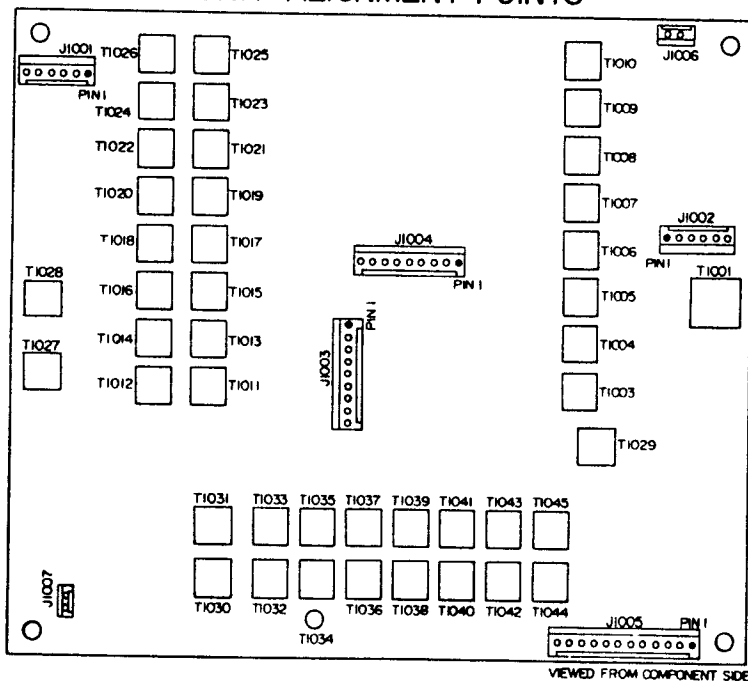

Figure 3-17 PREMIX BANDPASS FILTER

RF UNIT ALIGNMENT POINTS



RF UNIT

| BAND | CRYSTAL | FREQUENCY MHz | OSC OUTPUT TRANSFORMER |
|------|--------------------|---------------|------------------------|
| 80m | X ₃₀₀₅ | 17.9845 | T ₃₀₀₃ |
| 40m | X ₃₀₀₆ | 21.4845 | T ₃₀₀₄ |
| 30m | X ₃₀₀₄ | 24.4875 | T ₃₀₀₂ |
| 20m | X ₃₀₀₇ | 28.4875 | T ₃₀₀₅ |
| 17m | X ₃₀₁₃ | 32.4875 | T ₃₀₁₁ |
| 15m | X ₃₀₀₈ | 35.4875 | T ₃₀₀₆ |
| 12m | X ₃₀₁₄ | 38.4875 | T ₃₀₁₂ |
| 10mA | X ₃₀₀₉ | 42.4875 | T ₃₀₀₇ |
| 10mB | X ₃₀₀₁₀ | 42.9875 | T ₃₀₀₈ |
| 10mC | X ₃₀₁₁ | 43.4875 | T ₃₀₀₉ |
| 10mD | X ₃₀₁₂ | 43.9875 | T ₃₀₁₀ |

Table 3-4

| BAND | TRANSFORMER | PASS BAND MHz |
|------|---------------------------------------|---------------|
| 80m | T ₁₀₁₃ - T ₁₀₁₄ | 3.5-4.0 |
| 40m | T ₁₀₁₅ - T ₁₀₁₆ | 7.0-7.0 |
| 30m | T ₁₀₁₁ - T ₁₀₁₂ | 10.0-10.5 |
| 20m | T ₁₀₁₇ - T ₁₀₁₈ | 14.0-14.5 |
| 17m | T ₁₀₂₃ - T ₁₀₂₄ | 18.0-18.5 |
| 15m | T ₁₀₁₉ - T ₁₀₂₀ | 21.0-21.5 |
| 12m | T ₁₀₂₅ - T ₁₀₂₆ | 24.5-25.0 |
| 10m | T ₁₀₂₁ - T ₁₀₂₂ | 28.0-29.7 |

Table 3-5

ANTENNA COIL/RF BANDPASS FILTER ALIGNMENT

(1) Antenna Coil Adjustment

- a) For each band to be aligned, set the main tuning dial to the center of the band. For example, on 14 MHz, use 14.250 MHz, and on 10 meters use 29.0 MHz.
- b) Activate the marker generator, and adjust the coils shown below for maximum deflection on the S-meter when tuned to the marker signal.

| | |
|----|-------------------|
| 80 | T ₁₀₀₄ |
| 40 | T ₁₀₀₅ |
| 30 | T ₁₀₀₃ |
| 20 | T ₁₀₀₆ |
| 17 | T ₁₀₀₉ |
| 15 | T ₁₀₀₇ |
| 12 | T ₁₀₁₀ |
| 10 | T ₁₀₀₈ |

(2) RF Bandpass Filter Adjustment

- a) Connect an RF sweep generator to the antenna jack, and connect your oscilloscope to the lead of R₁₀₅₀ (RF Unit) as shown in the drawing.
- b) Adjust the transformers shown in Table 3-5 for the pattern shown in Figure 3-18.

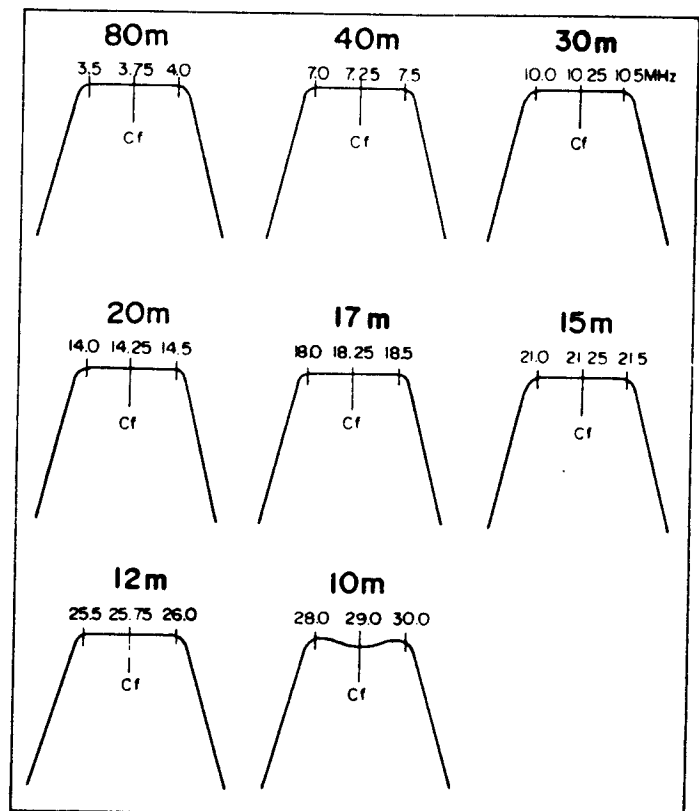
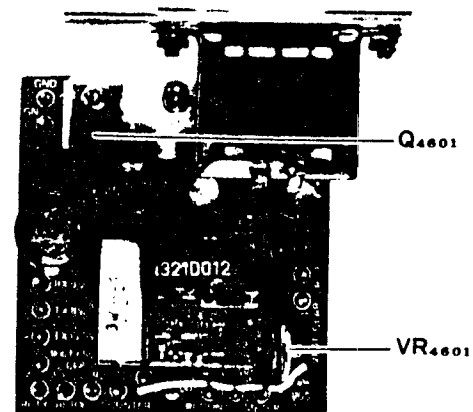

Figure 3-18 RF BANDPASS FILTER



AVR UNIT

ANTENNA TRAP COIL ALIGNMENT

- a) Set the BAND switch to 40, and set the main tuning dial to 7.5 MHz. Connect an audio voltmeter to the speaker jack.
- b) Connect a signal generator to the antenna jack, and apply a 100 dB signal at 8.9875 MHz. Adjust T₁₀₀₁ (RF Unit) for minimum indication on the audio voltmeter.

- b) Set the CLAR control to the 12 o'clock position. Push the CLAR switch, and listen for any difference in the beat tone of the incoming signal. If the tone is not exactly the same as with the clarifier OFF, adjust VR₄₆₀₁ (AVR Unit) for the required coincidence of tones in the ON and OFF conditions.

PO METER SETTING

- a) Set the BAND switch to 20, and the MODE switch to CW. Close the MOX switch and the CW key, and set the transmitter power output to 110 watts, as indicated on the wattmeter.
- b) Adjust VR₄ (main chassis) so that exactly two of the yellow LEDs are illuminated.

CLARIFIER ALIGNMENT

- a) On any band, apply a signal from the signal generator, and tune the receiver to the output from the signal generator. If desired, you may use the marker signal instead of a signal generator. With the clarifier OFF, note the beat tone of the incoming signal, with the MODE switch set to CW

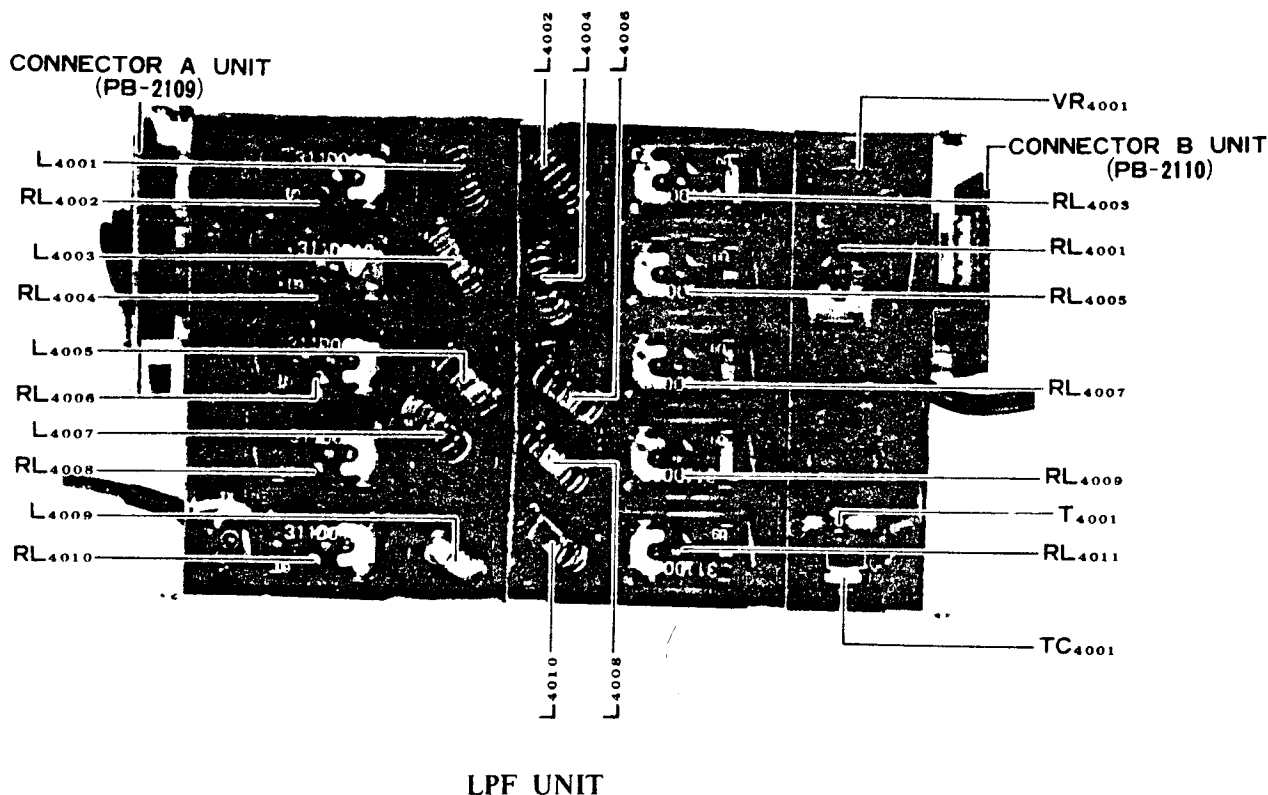

DIRECTIONAL COUPLER BALANCE

- a) Set the BAND switch to 15, and the MODE switch to CW. Connect the MINUS (-) lead of your DC voltmeter to the center post of VR₄₀₀₁ (connect the positive lead of the voltmeter to ground).
- b) Transmit on CW, and adjust TC₄₀₀₁ for a minimum indication on the voltmeter.

ALC CIRCUIT ALIGNMENT

- a) Set the MODE switch to CW. On each band, check the maximum power output. Set VR₂₀₀₅ for a maximum power output of 110 watts. Use a 50 ohm dummy load for this step.
- b) Connect a 17 ohm load to the antenna jack (three 50 ohm dummy loads connected in parallel). Transmit on 20 meter CW, and adjust VR₄₀₀₁ for a maximum power output of 50 watts as indicated on the wattmeter.

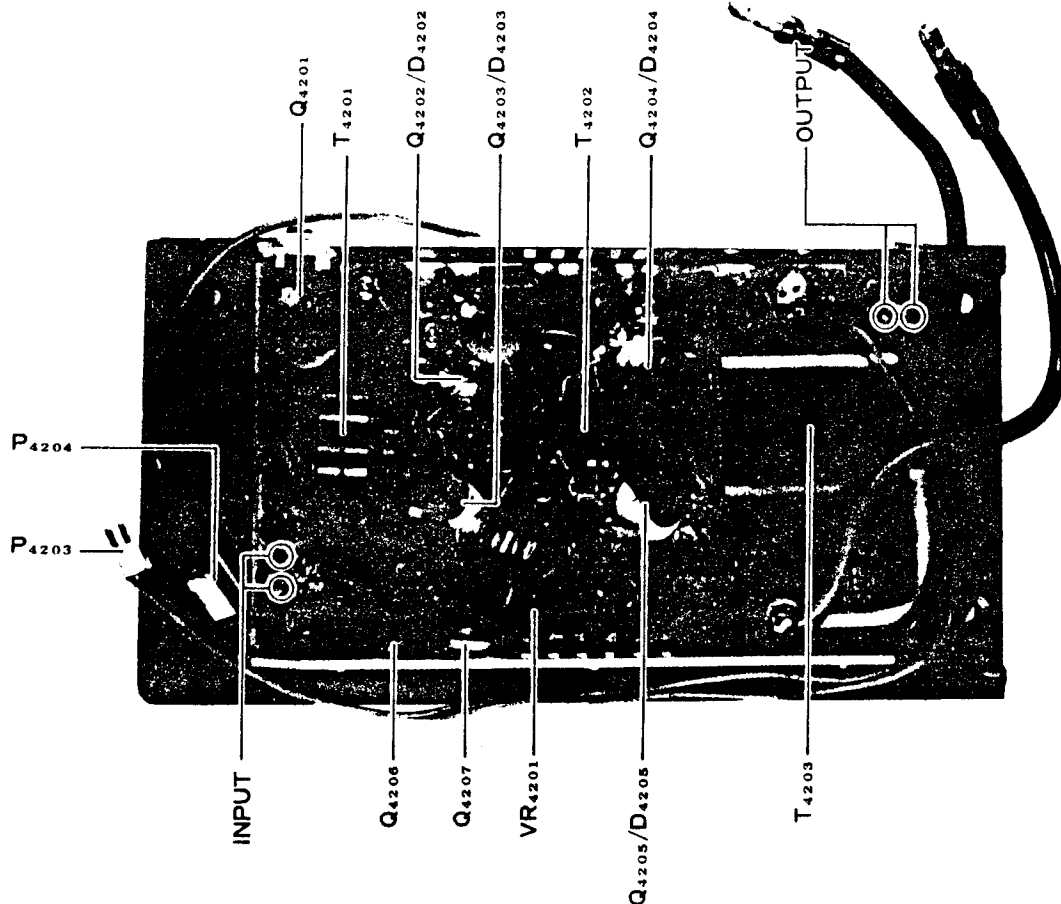

100W PA UNIT

FAULT IDENTIFICATION AND LOCALIZATION

The process of troubleshooting any electronic equipment is highly individualistic. Fundamentally, though, the process is one of logical elimination.

Begin with a visual inspection of the transceiver, looking for broken, discolored, or charred components. Smell the unit, as transformers smell differently than resistors, etc. If you do find a component that is cooked, remember that another fault may have caused the destruction of the part you have located.

Initially, turn on the receiver, and check out **only** the RX side. Any malfunctions you detect on the receiver side should be repaired before you check out the transmitter. In doing this, you may well cure the entire problem, as much circuitry is shared on TX and RX.

The logical process of fault identification is to determine the missing function (no RX on LSB), then the board at fault (AF UNIT), then the bad circuit (LSB oscillator), then the malfunctioning part (X₃₀₀₂).

If, after the receiver inspection is completed, all appears OK, switch to the transmit side, following the same logical procedure (function -- board circuit -- component). Concentrate on those sections unique to the transmit side, as you have already performed a thorough checkout of all receiver and shared circuits. Use only a dummy load. NEVER troubleshoot using an antenna.

In this manual, we will provide troubleshooting advice which leads you directly to suspect components. As there are some 2,200 parts in the FT-707, though, it obviously is impossible for us to trace the path of every possible malfunction in the radio. Therefore, if our tips do not lead to identification of the trouble, the logical elimination process is the way to go.

TROUBLESHOOTING

A FUNDAMENTAL ANALYSIS OF THE TROUBLE

The failure may be caused by one of the following:

- 1) Mechanical defect
- 2) Electrical defect
- 3) Others (Murphy's Law, etc.)

1. MECHANICAL DEFECTS

Typical examples of mechanical defects encountered by the technician are:

- a) Damage from shock during transportation (remember the unit was probably subjected both to sea and truck shipment).
- b) Damage caused by vibration in service.
- c) Damage caused by forcing stubborn knobs or switches. This difficulty is usually preceded by one of the two above defects.

2. ELECTRICAL DEFECTS

Typical electrical defects encountered are:

- a) Part(s) failure caused by aging;
- b) Failures caused by improper application of supply voltage or by voltage spikes;
- c) Improper operation (e.g. transistors without load – this usually points to a failure elsewhere, in addition to the damaged transistor or IC).
- d) Loose connections, at the power receptacle, caused by cold solder joints, etc.

3. OTHERS

Among the miscellaneous types of failures or difficulties encountered are:

- a) Antenna troubles – be on the alert for antenna problems when the owner of the just-aligned transceiver complains of difficulty “when I switch to the antenna.”
- b) Poor power source – extremely high or low voltage, insufficient capacity, poor regulation, etc.
- c) Murphy's Law – use of a non-Yaesu microphone with different connections, for example. (See page 1-7.)

RECEIVE MODE

| Problem | Condition | Probable Cause(s) |
|-------------------------|---|--|
| (1) No DC power applied | (a) Fuse OK | <ul style="list-style-type: none"> ★ Defective power switch ★ Defective D_{01}, D_{02} ★ Defective RL_{01} ★ Loose contact at power jack |
| | (b) Fuse blows | <ul style="list-style-type: none"> ★ Defective power connector J_{08} ★ Short at CH_{01} ★ +13.5 V line shorted |
| (2) No reception | (a) S-meter OK, no audio output from speaker | <ul style="list-style-type: none"> ★ Defective speaker ★ Defective EXT SP jack ★ Defective audio circuit around Q_{3022} ★ Defective LPF circuit around Q_{3020}, Q_{3021} |
| | (b) No audio output on some mode LSB USB/CW AM LSB/USB/CW | <ul style="list-style-type: none"> ★ Defective D_{3004}, X_{3001} ★ Defective D_{3005}, X_{3002} ★ Defective Q_{2018}, D_{2023} and associated circuit ★ Defective RL_{3001} |
| | (c) No audio output, S-meter off scale | <ul style="list-style-type: none"> ★ Defective RF GAIN control ★ Defective Q_{2007} ★ AGC line shorted |
| | (d) AF circuit appears OK, no S-meter deflection | <ul style="list-style-type: none"> ★ Defective T_{3001} ★ Defective T_{2008} - T_{2010} ★ Defective Q_{2004}, Q_{2005} ★ Defective T_{2001} - T_{2004} ★ Defective Q_{2001} - Q_{2003}, Q_{2009} ★ Defective D_{2001} - D_{2003} ★ Defective Q_{2014} ★ Defective D_{2009} - D_{2016}, D_{2030}, D_{2031} ★ Defective XF_{2001} - XF_{2004} ★ Detuned or defective T_{2001} - T_{2010} ★ Defective Q_{1008}, Q_{1009} ★ No local signal |
| (3) Partial reception | (a) Poor reception on one or more bands (some bands OK) | <ul style="list-style-type: none"> ★ Low local signal level ★ Check tuning of the bandpass filter T_{1003} - T_{1026} (*T_{1001} - T_{1018}) ★ Bandswitched control line open or shorted |

SERVICING

| | | |
|------------------------|-----------------------------------|---|
| (4) Self-oscillation | (a) OK on transmit | ★ TX 13.5 V line shorted to RX 13.5 V line ★ Check TX line at each board, TX/RX switching diodes, and switches |
| (5) Marker inoperative | (a) RX OK, no marker signal heard | ★ Defective MARKER switch ★ Check voltage at pin 14 of Q ₃₀₃₇ ★ Defective X ₃₀₁₅ ★ Defective Q ₃₀₃₆ - Q ₃₀₃₈ |

TRANSMITTER

| Problem | Condition | Probable Cause(s) |
|---------------------------------|--|---|
| (1) No power output | (a) No power output | <ul style="list-style-type: none"> ★ Loose contact at J₁₀₀₂ ★ Loose contact at J₄₀₀₂ ★ Defective RL₄₀₀₁ - RL₄₀₁₁ ★ Cold solder joint at band switch ★ Defective Q₁₀₀₂, Q₁₀₀₃ ★ Defective Q₁₀₀₄, Q₁₀₀₅, and associated circuit ★ Defective RX/TX switching diodes on RF Unit PB-2093 (*PB-2201) ★ Defective Q₁₀₀₈ ★ Low premix local signal level ★ Defective Q₂₀₀₇, Q₂₀₀₈ |
| (2) Poor TX performance | <p>(a) No power output on LSB/USB and no modulation on AM mode</p> <p>(b) No power output on LSB only</p> <p>(c) No power output on USB only</p> <p>(d) No power output on CW/AM</p> <p>(e) No CW keying</p> | <ul style="list-style-type: none"> ★ Defective microphone ★ Loose contact at microphone connector ★ Defective Q₃₀₀₆, Q₃₀₀₇, Q₃₀₀₉ ★ Defective MIC GAIN control ★ Defective RL₃₀₀₁ ★ Defective D₃₀₀₄, X₃₀₀₁, TC₃₀₀₁ ★ Loose contact at pin 7 of J₃₀₀₂ ★ Defective D₃₀₀₅, X₃₀₀₂, TC₃₀₀₂ ★ Loose contact at pin 6 of J₃₀₀₂ ★ Defective Q₃₀₀₂, Q₃₀₀₃, Q₃₀₃₉, and associated circuit ★ Defective D₃₀₀₆, X₃₀₀₃, TC₃₀₀₃ ★ Defective key jack ★ Defective Q₁₀₀₄, Q₁₀₀₅ |
| (3) No changeover from RX to TX | <p>(a) TX OK in MOX position</p> <p>(b) No TX in MOX position</p> <p>(c) VOX inoperative</p> | <ul style="list-style-type: none"> ★ Failure in MIC or PTT line ★ Loose MIC jack or plug connection ★ Defective Q₃₀₁₉, Q₃₀₄₀, D₃₀₁₇, D₃₀₄₃ ★ Defective Q₃₀₁₅ - Q₃₀₁₇, Q₃₀₁₃ ★ If no CW semi-break-in, check Q₃₀₁₀ and associated circuit |
| (4) No return to RX from TX | | <ul style="list-style-type: none"> ★ PTT line grounded ★ Defective Q₃₀₁₉ and associated circuit ★ Defective VOX circuit |

SERVICING

| | | |
|------------------------------|-----------------------------------|--|
| (5) Fuse blows on transmit | (a) OK on RX | <ul style="list-style-type: none"> ★ Defective PA unit ★ TX 13.5 V line grounded |
| (6) Abnormal meter operation | (a) Meter does not deflect at all | <ul style="list-style-type: none"> ★ Defective D₄₇₀₁ --D₄₇₁₀ ★ Defective RL₄₆₀₂ ★ Defective Q₄₇₀₁ |
| | (b) S-meter does not function | <ul style="list-style-type: none"> ★ AGC line shorted ★ Defective Q₂₀₁₈ , Q₂₀₁₉ , Q₂₀₂₀ , Q₂₀₂₁ |
| | (c) ALC meter does not function | <ul style="list-style-type: none"> ★ Defective Q₂₀₂₀ --Q₂₀₂₅ ★ Defective D₄₀₀₂ --D₄₀₀₇ , T₄₀₀₁ |

COMMON CIRCUITS

| Problem | Condition | Probable Cause(s) |
|------------------|--|--|
| (1) Local Unit | (a) Crystal oscillator does not oscillate | <ul style="list-style-type: none"> ★ Cold solder joint between band switch and J₃₀₀₆ ★ Defective Q₃₀₂₅ - Q₃₀₃₅ ★ Defective X₃₀₀₄ - X₃₀₁₄ ★ Defective T₃₀₀₂ - T₂₀₁₂ ★ Defective D₃₀₂₉ - D₃₀₃₉ |
| | (b) No premix local output | <ul style="list-style-type: none"> ★ Defective Q₁₀₀₆ ★ Detuned or defective premix BPF T₁₀₃₀ - T₁₀₄₅ (*T₁₀₃₇ - T₁₀₅₂) ★ Defective D₁₀₄₆ - D₁₀₆₁ (*D₁₀₅₉ - D₁₀₇₄) ★ Defective Q₁₀₁₀ - Q₁₀₁₂ ★ No VFO output |
| (2) Counter Unit | (a) Digital display does not work | <ul style="list-style-type: none"> ★ Defective voltage regulator Q₀₁ ★ Defective display LED ★ Defective Q₄₄₀₆ - Q₄₄₁₁, Q₄₄₁₃ - Q₄₄₁₉ ★ Defective Q₄₄₁₂ |
| | (b) Display incorrect | <ul style="list-style-type: none"> ★ Low premix local signal input ★ Defective Q₄₄₀₁, Q₄₄₀₃, Q₄₄₀₄ ★ Defective Q₄₄₁₂ ★ Defective Q₁₀₁₃ |
| (3) Clarifier | (a) Frequency jumps with clarifier on | <ul style="list-style-type: none"> ★ Defective CLAR control, RL₄₆₀₂ |
| | (b) OFF and "0" condition do not coincide in frequency | <ul style="list-style-type: none"> ★ Defective CLAR control, VR₄₆₀₁, RL₄₆₀₂ |
| | (c) Frequency jumps with clarifier off, OK with clarifier on | <ul style="list-style-type: none"> ★ Defective VR₄₆₀₁, RL₄₆₀₂ |

RELAY CONNECTION INFORMATION

Should the need for replacement of relays become necessary, or if you are trying to verify proper relay operation, the diagrams below should help you.

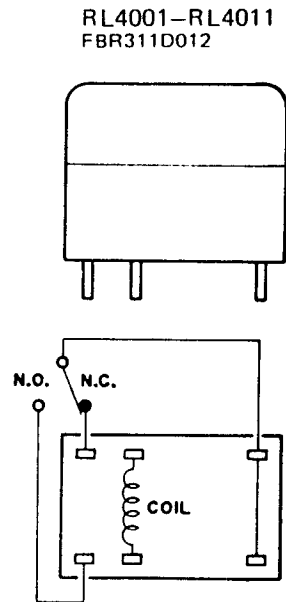
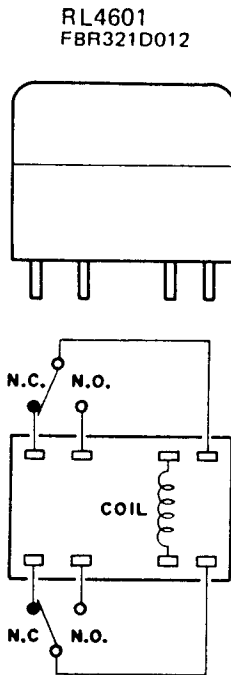
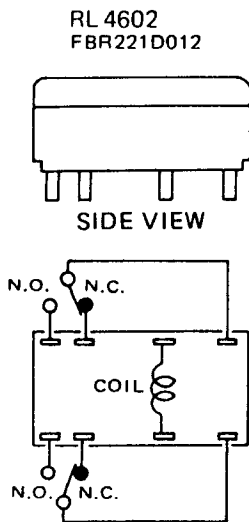
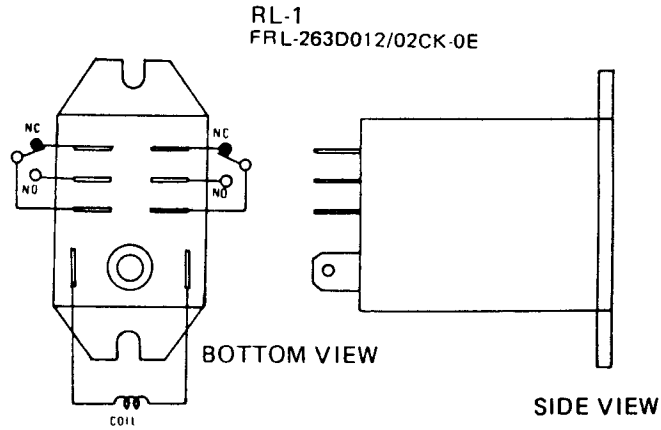
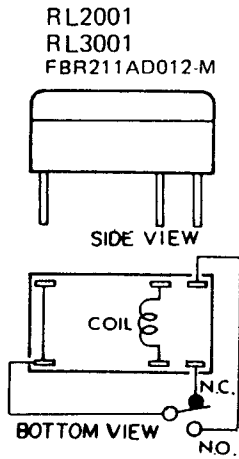

PARTS LAYOUT
RF UNIT(PB-2093A) Early model

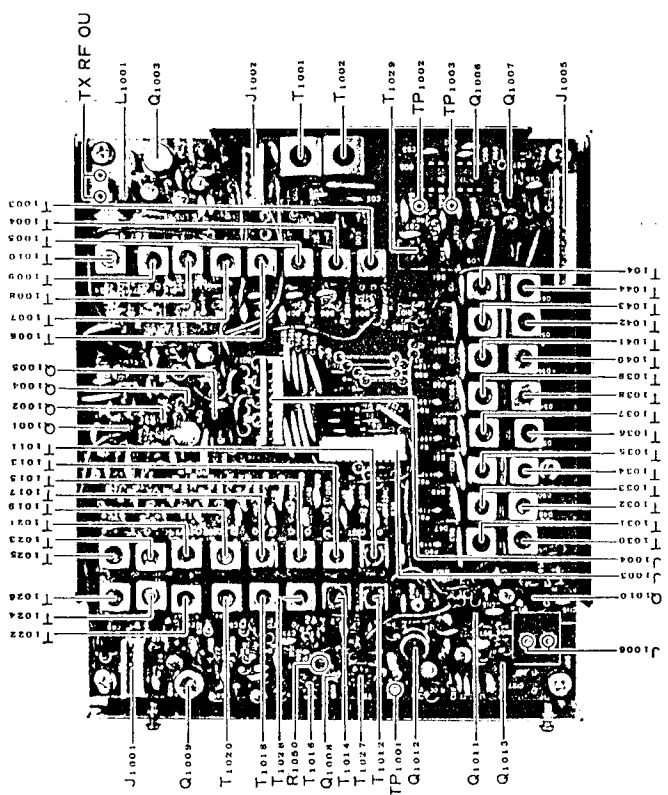
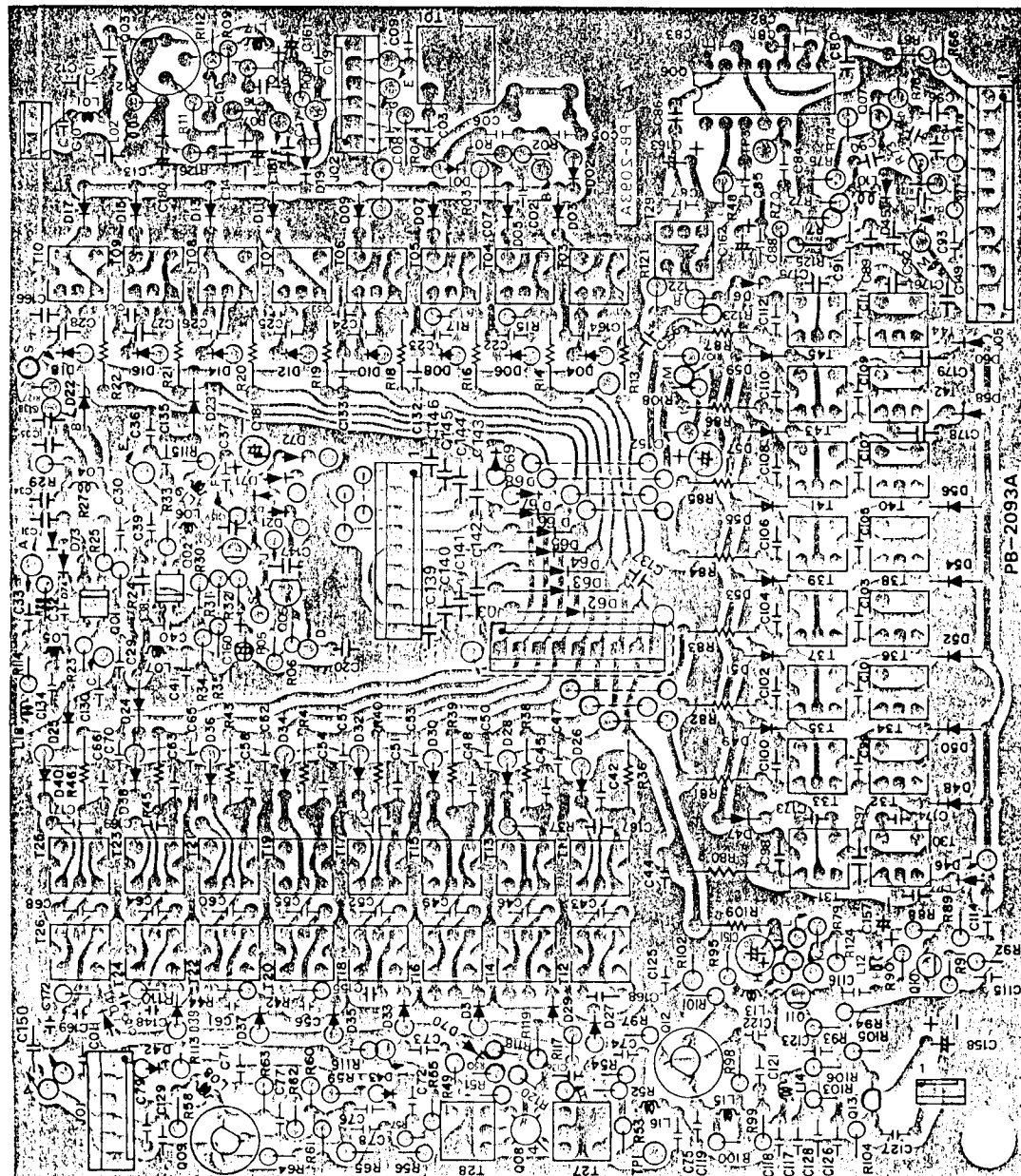

RF UNIT

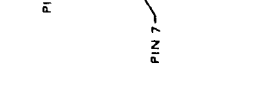
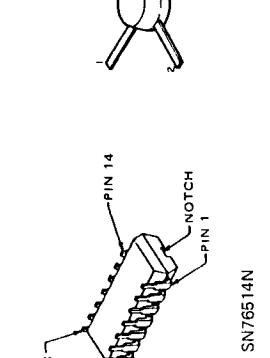
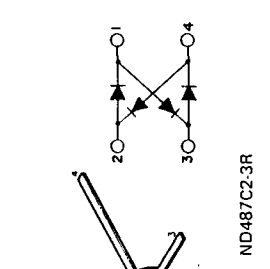
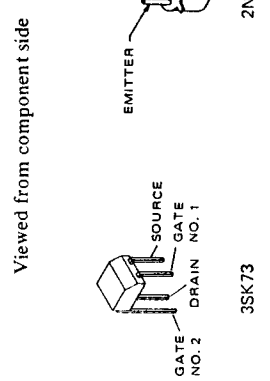
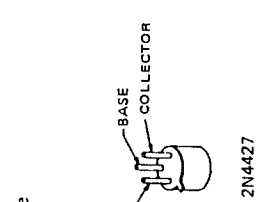
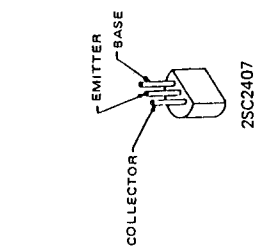
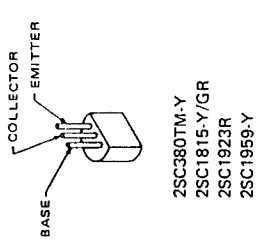

PARTS LAYOUT
RF UNIT(PB-2093A) Early model

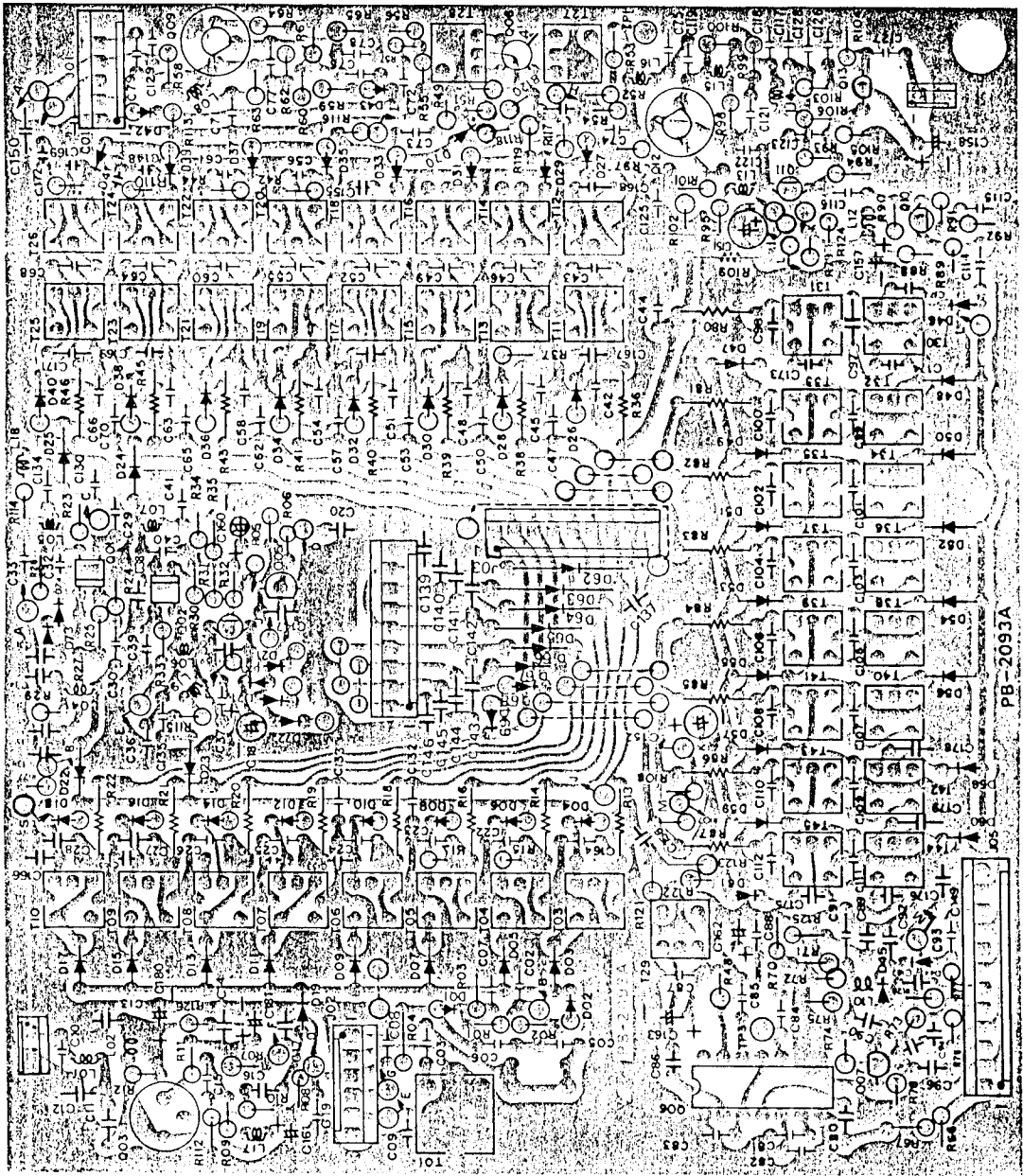

Viewed from foil side

VOLTAGE CHART
(DC VOLTS)

FT-707 RF UNIT (PB-2093)

| | E(S) | C(D) | B(G1) | G(2) | |
|-------|------|------|-------|------|---|
| Q1001 | 1.5 | 11.3 | 1.6 | 2.4 | R |
| Q1002 | 1.3 | 11.8 | 1.1 | 2.2 | T |
| Q1003 | 5.4 | 12.7 | 6.2 | | T |
| Q1004 | 0 | 0.2 | 0.7 | | T |
| Q1005 | 0 | 1.5 | 0 | | T |
| Q1007 | 2.4 | 10.8 | 3.1 | | R |
| Q1009 | 6.5 | 12.0 | 7.1 | | R |
| Q1010 | 1.5 | 10.1 | 2.2 | | R |
| Q1011 | 1.5 | 10.3 | 2.2 | | R |
| Q1012 | 2.8 | 13.3 | 3.5 | | R |
| Q1013 | 3.3 | 6.1 | 4.0 | | R |

| | | | | | | | | | | | | | | |
|-------|---|------|------|-----|-----|---|---|-----|-----|-----|-----|------|----|---|
| 1 | 2 | 3 | 4 | 5 | 6 | 7 | 8 | 9 | 10 | 11 | 12 | 13 | 14 | |
| Q1006 | 0 | 12.3 | 10.5 | 6.1 | 3.9 | 0 | 0 | 3.9 | 6.1 | 6.1 | 6.1 | 10.4 | 0 | R |

BAND
MODE
RF GAIN
NB
ACC

20m
USB
MAX
OFF
SLOW

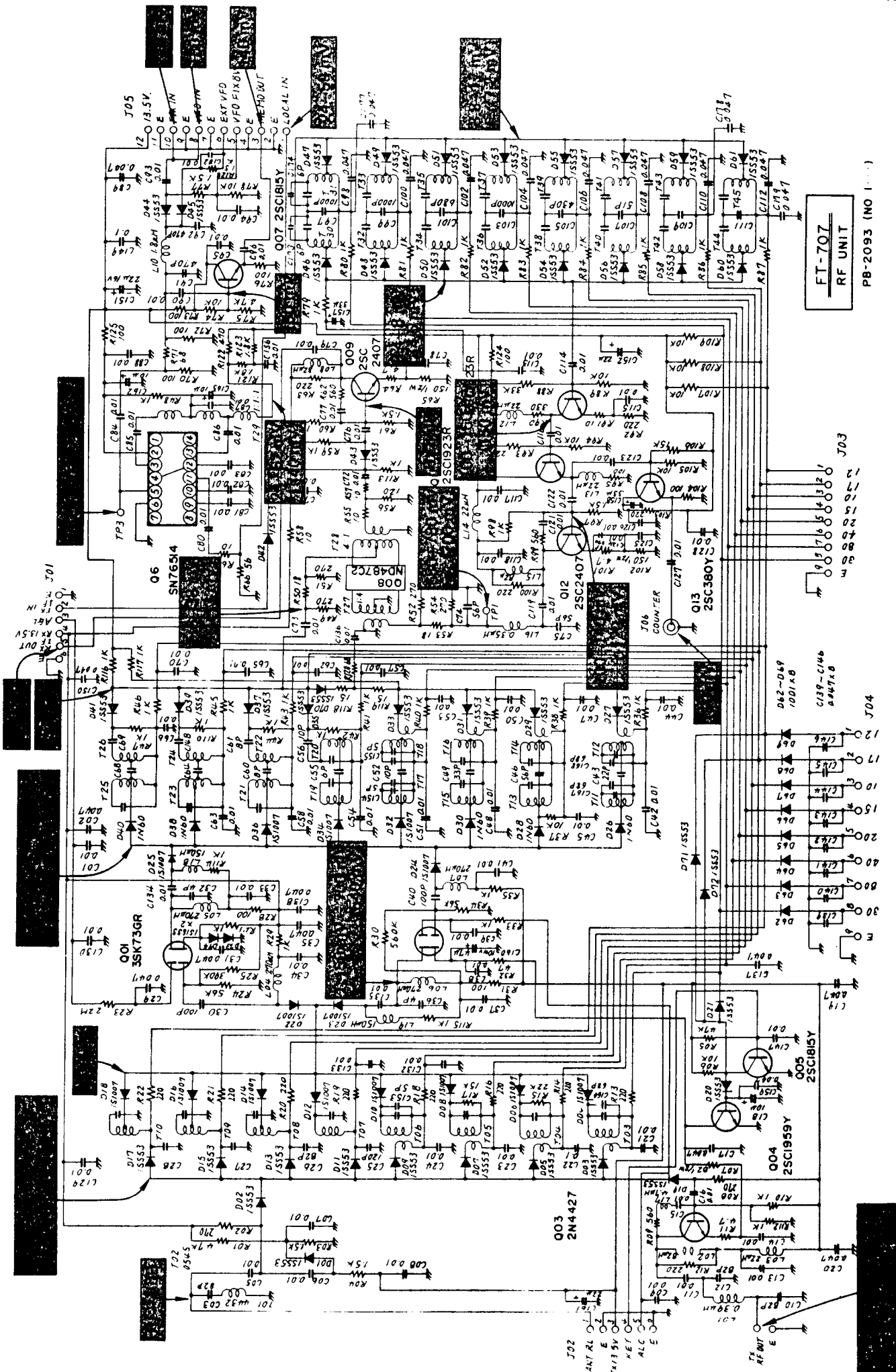

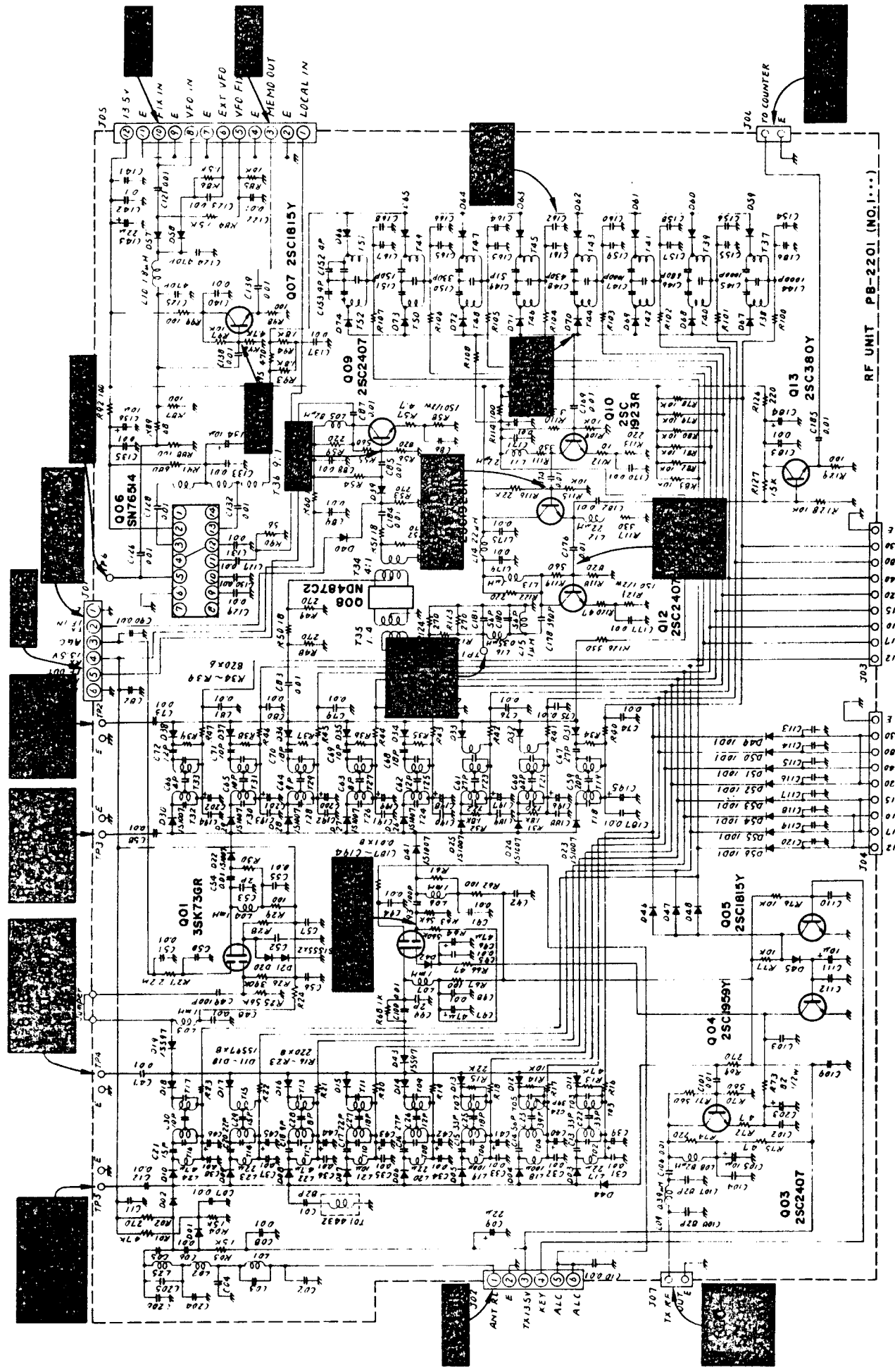

FI-707
RF UNIT

- NOTES
- 1 ALL RESISTORS ARE 1/4W UNLESS OTHERWISE NOTED
 - 2 ALL CAPACITORS ARE 0.047UF UNLESS OTHERWISE NOTED
 - 3 ALL ELECTROLYTIC CAPACITORS ARE 33MF OTHERWISE NOTED
 - 4 ALL DIODES ARE .1S353 UNLESS OTHERWISE NOTED

RF UNIT(PB-2201) After prod.11.

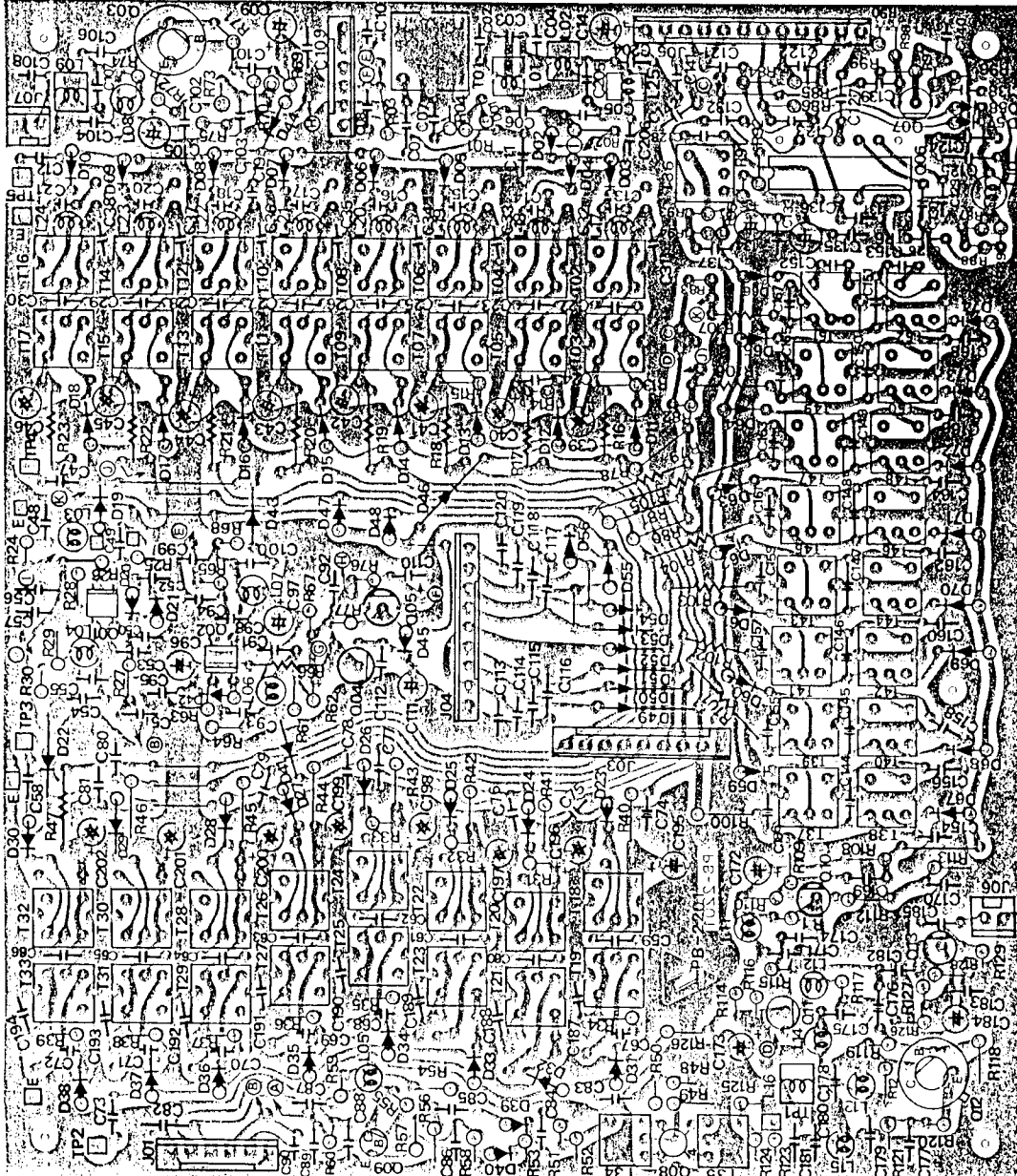
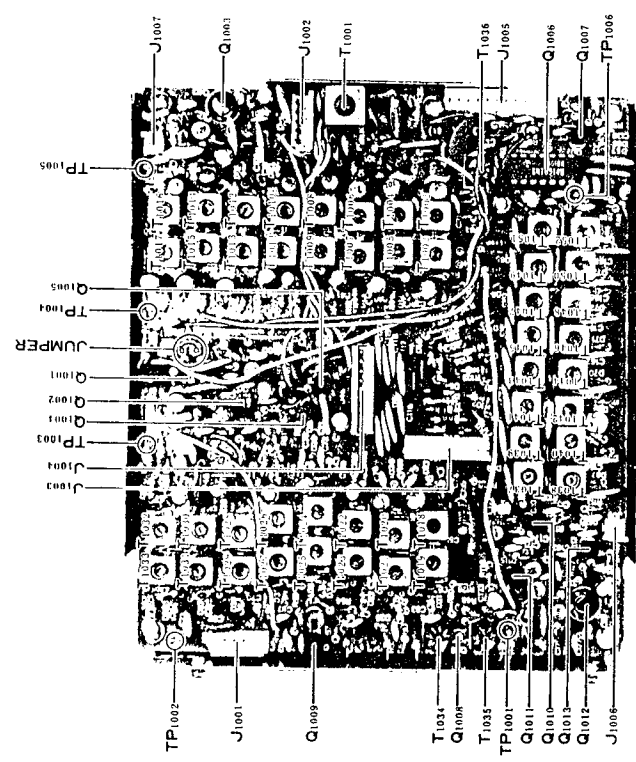

Viewed from component side

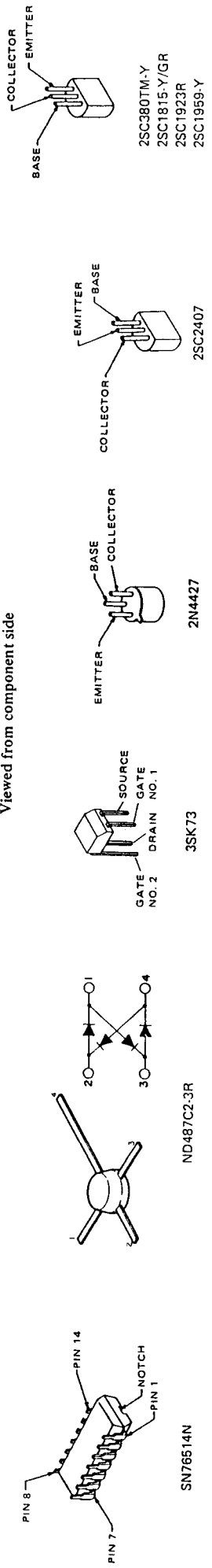

PARTS LAYOUT
RF UNIT(PB-2201) After prod.11.

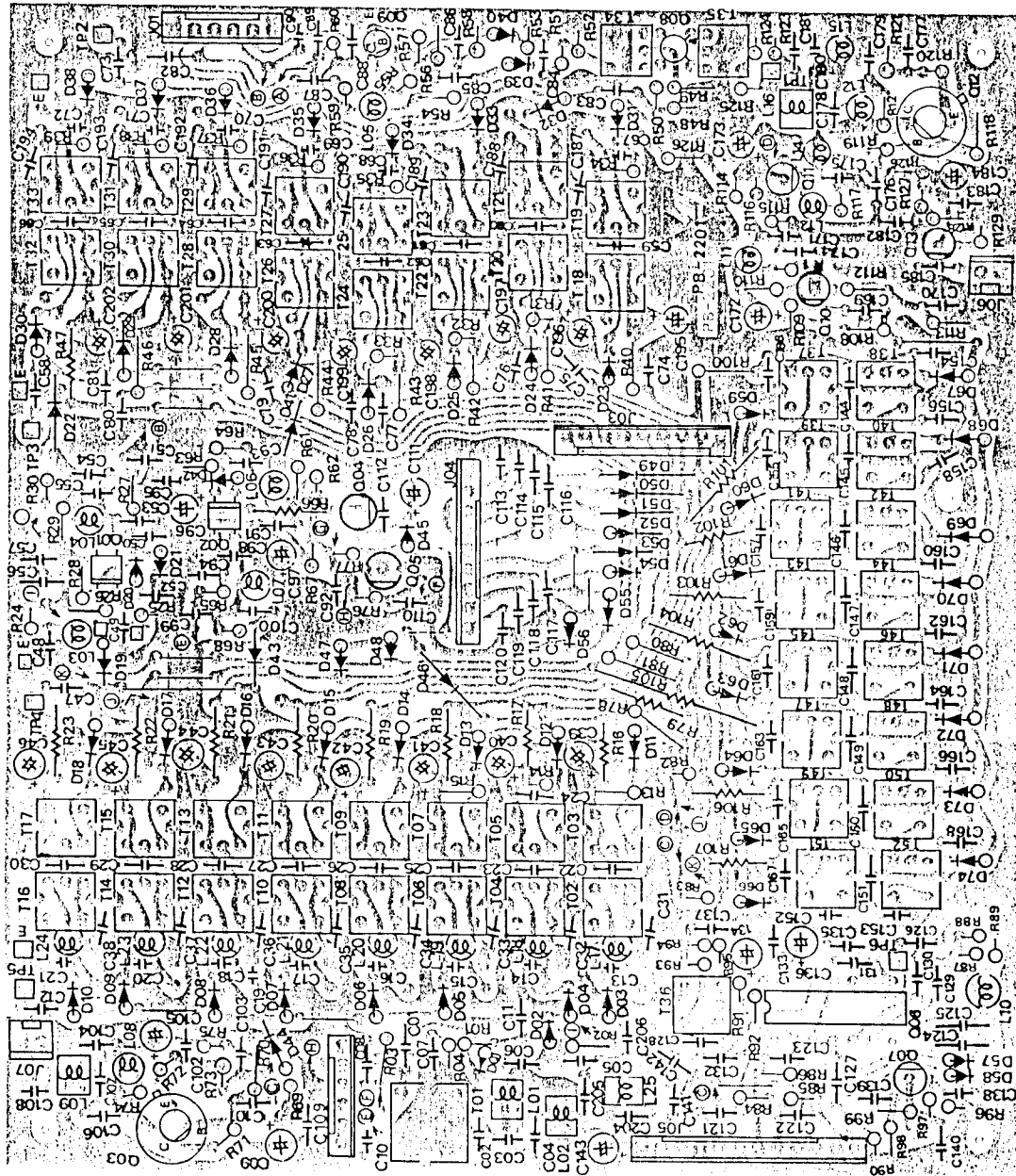

Viewed from foil side

VOLTAGE CHART
(DC VOLTS)

FT-707 RF UNIT (PB-2201)

| | E(S) | C(D) | B(G1) | G(2) | |
|-------|------|------|-------|------|---|
| Q1001 | 1.6 | 11.6 | 1.5 | 2.5 | R |
| Q1002 | 1.2 | 11.8 | 1.1 | 2.2 | T |
| Q1003 | 5.4 | 12.7 | 5.9 | - | T |
| Q1004 | 0 | 0.2 | 0.74 | - | T |
| Q1005 | 0 | 1.5 | 0 | - | T |
| Q1007 | 2.3 | 10.8 | 3.0 | - | R |
| Q1009 | 6.2 | 12.0 | 6.9 | - | R |
| Q1010 | 1.4 | 9.9 | 2.2 | - | R |
| Q1011 | 2.7 | 13.4 | 3.4 | - | R |
| Q1012 | 7.0 | 13.3 | 7.6 | - | R |
| Q1013 | 2.2 | 8.5 | 2.8 | - | R |

| | 1 | 2 | 3 | 4 | 5 | 6 | 7 | 8 | 9 | 10 | 11 | 12 | 13 | 14 |
|-------|---|------|------|-----|-----|---|---|---|-----|-----|-----|-----|------|----|
| Q1006 | 0 | 12.6 | 10.6 | 6.0 | 3.8 | 0 | 0 | 0 | 3.8 | 6.0 | 6.0 | 6.0 | 10.6 | 0 |

BAND 20m
 MODE USB
 RF GAIN MAX
 NB OFF
 AGC SLOW

**PARTS LAYOUT
IF UNIT(PB-2094A)**

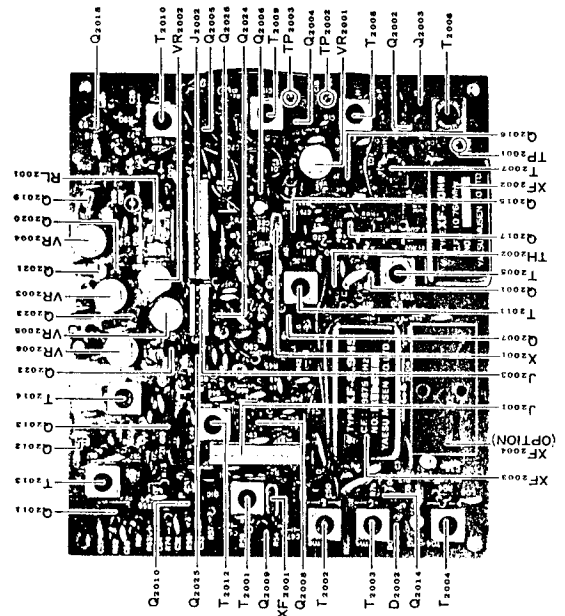
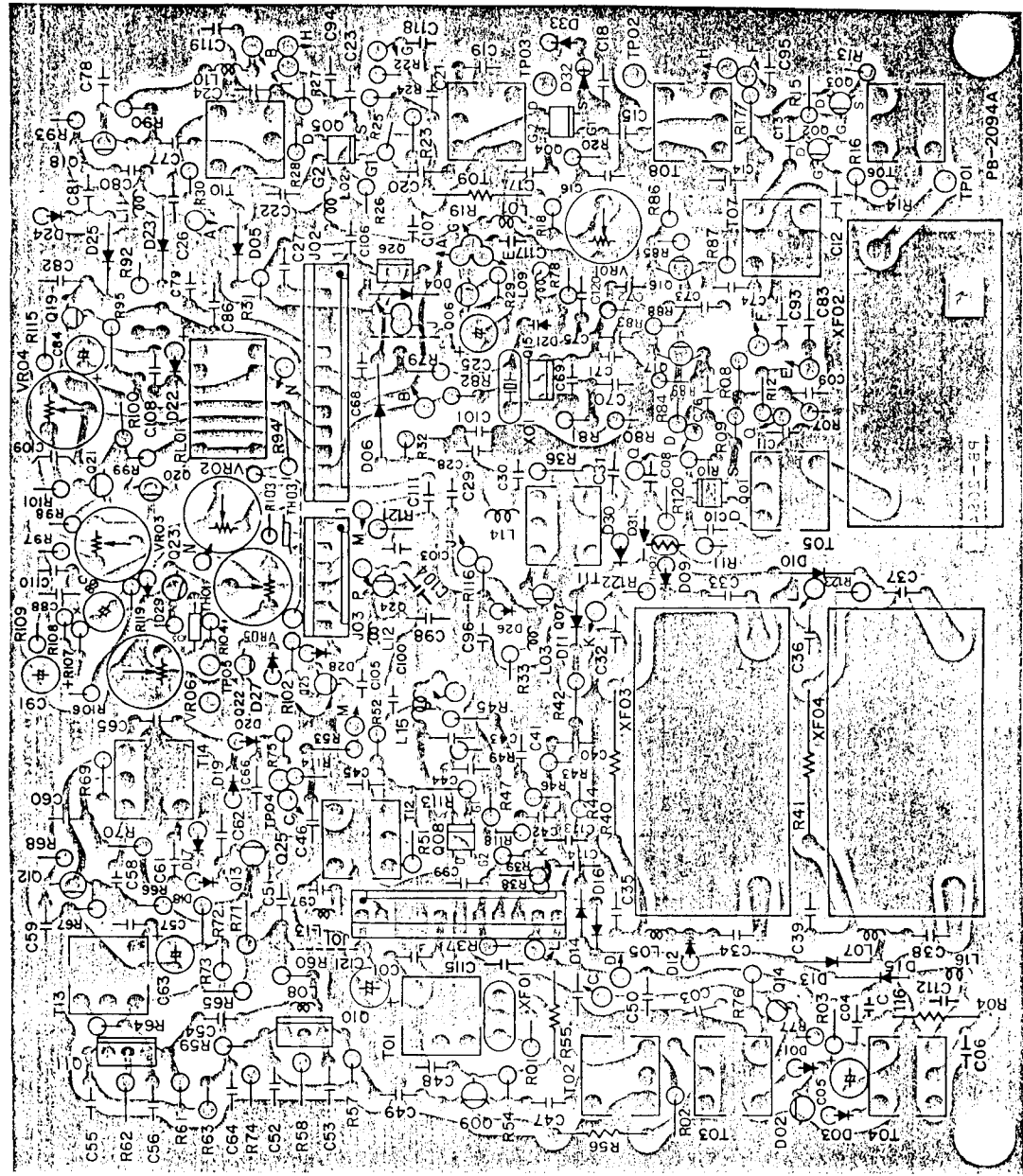

IF UNIT

Viewed from component side

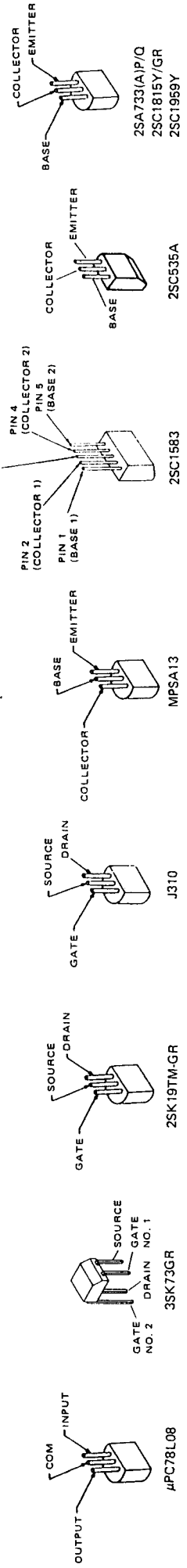

**PARTS LAYOUT
IF UNIT(PB-2094A)**

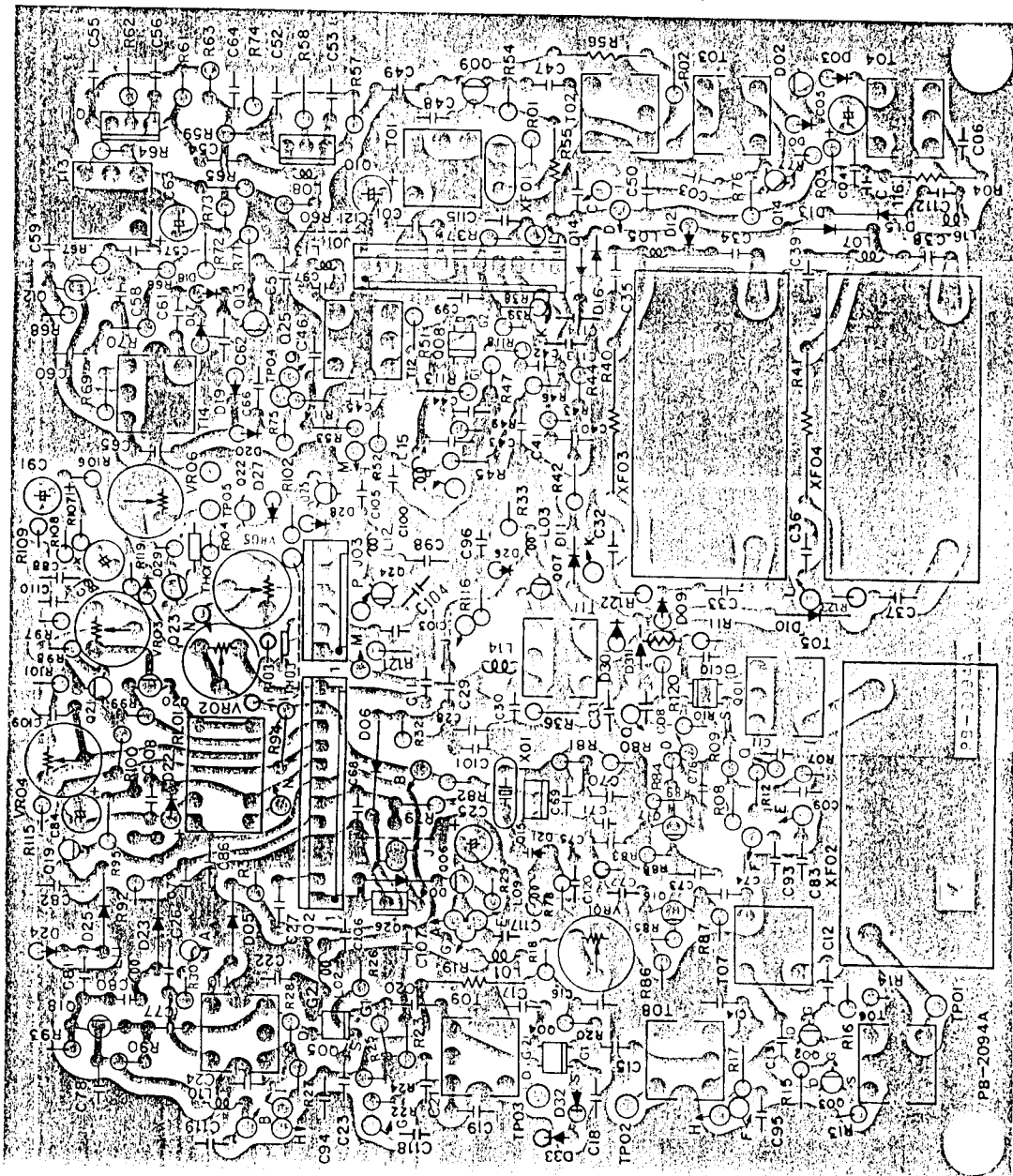

Viewed from foil side

**VOLTAGE CHART
(DC VOLTS)**

FT1707 IF UNIT (PB-2094)

| | (E(S)) | (C(D)) | (R(G1)) | (G2) | |
|-------|--------|--------|---------|------|------------|
| Q2001 | 0.4 | 8.1 | 0 | 0.4 | R |
| Q2002 | 1.5 | 7.3 | 0 | | R |
| Q2003 | 1.5 | 7.3 | 0 | | R |
| Q2004 | 1.3 | 7.4 | 0.9 | *4.5 | R |
| Q2005 | 1.8 | 7.4 | 1.6 | *4.5 | R |
| Q2006 | 8.6 | 12.0 | 9.3 | | R |
| Q2007 | 1.8 | 8.0 | 0 | | T |
| Q2008 | 0.8 | 7.5 | 0.7 | 2.2 | T |
| Q2009 | 3.0 | 6.6 | 3.6 | | R |
| Q2012 | 1.3 | 8.0 | 1.9 | | R (NB: ON) |
| Q2013 | 0 | 7.6 | 0 | | R (NB: ON) |
| Q2014 | 0 | 4.1 | 0 | | R |
| Q2015 | 1.9 | 7.5 | 2.9 | | R |
| Q2016 | 1.7 | 7.0 | 2.1 | | R |
| Q2017 | 3.6 | 7.0 | 4.2 | | R |
| Q2018 | 3.3 | 8.0 | 3.9 | | R |
| Q2019 | 0 | *4.5 | 0 | | R |
| Q2020 | 5.2 | 8.1 | 2.8 | | R |
| Q2021 | 4.7 | 0.2 | 4.2 | | R |
| Q2022 | 0 | 0/5 | 0.7/6.1 | | R/T |
| Q2023 | 0 | 3.5 | 0 | | T |
| Q2024 | 0 | 2.2 | 0 | | T |
| Q2025 | 1.3 | 0 | 10.2 | | T |

* HIGH IMPEDANCE

| | E | B1 | B2 | C1 | C2 | |
|-------|-----|-----|-----|-----|-----|------------|
| Q2010 | 1.1 | 1.7 | 1.1 | 7.9 | 7.9 | R (NB: ON) |
| Q2011 | 1.1 | 1.7 | 1.1 | 7.9 | 7.9 | R (NB: ON) |

BAND 20m
MODE USB
REF GAIN MAX
NB OFF

PARTS LAYOUT
AF UNIT(PB-2095A)

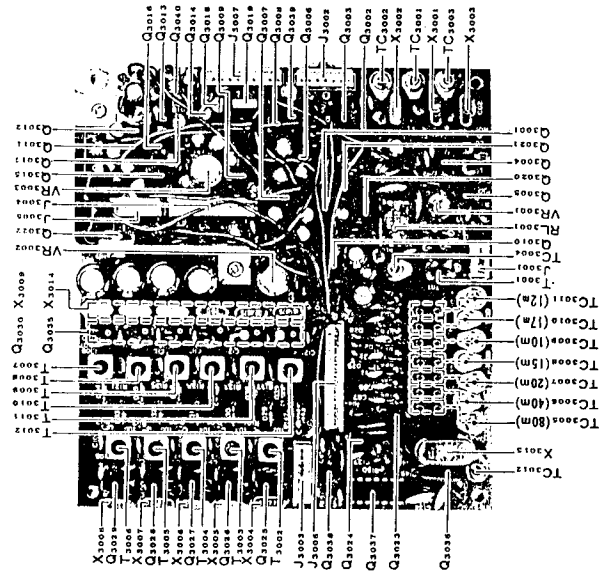
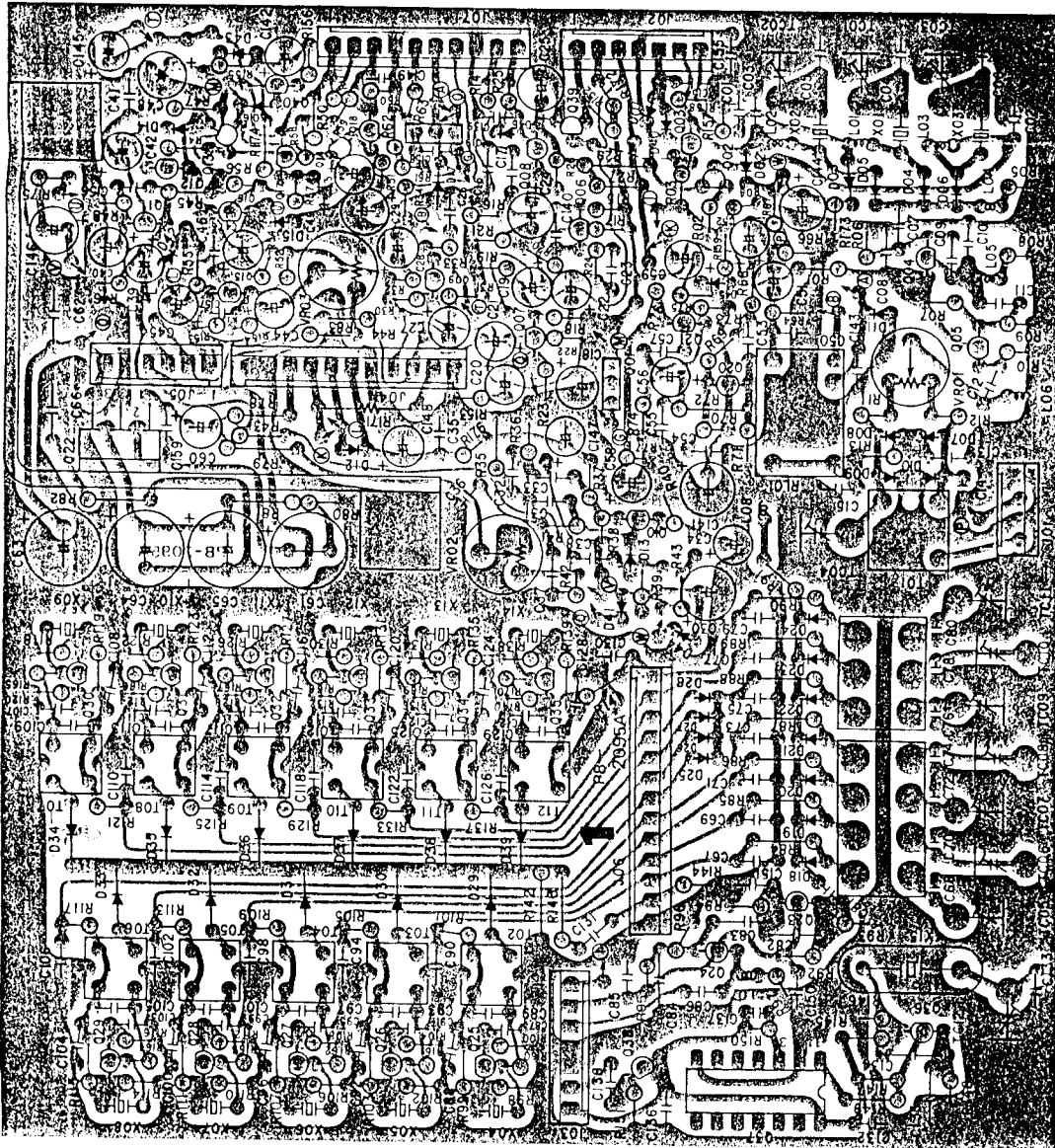

AF UNIT

Viewed from component side

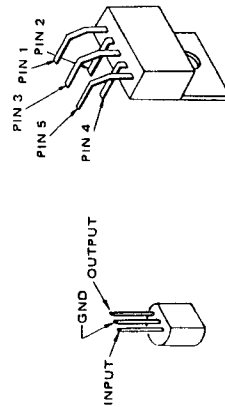

78L05/08

μPC2002V

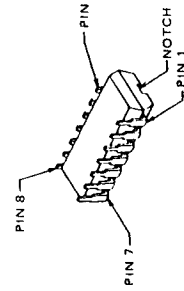

F4024

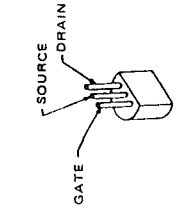

25K19TM-GR/Y

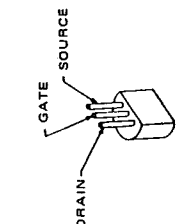

25K30A-Y

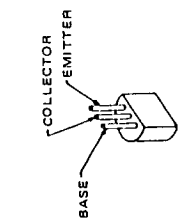

25A733(A)P/Q
25C380TM-Y
25C732TM-GR
25C1815Y/GR
25C1959Y

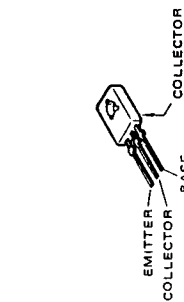

25C496

**PARTS LAYOUT
AF UNIT (PB-2095A)**

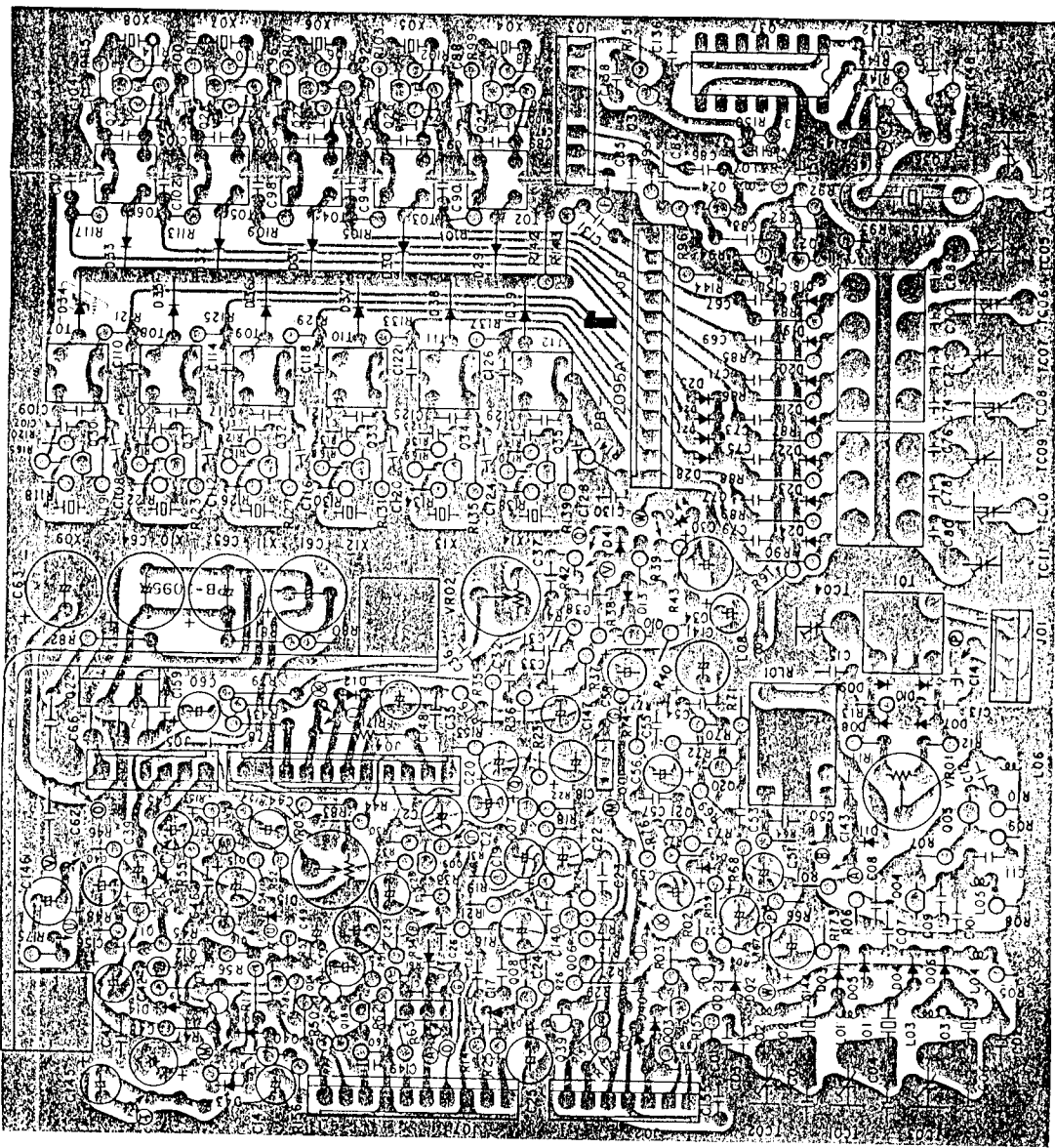

Viewed from foil side

**VOLTAGE CHART
(DC VOLTS)**

FT1707 AF UNIT (PB-2095)

| | (E5) | (C/D) | (B/G1) | (C2) | |
|-----------------|------|-------|--------|------|---------------|
| Q3002 | 6.7 | 6.7 | 6.1 | | T (CW) |
| Q3003 | 6.3 | 6.4 | 7.0 | | T (AM) |
| Q3004 | 0.7 | 6.0 | 0 | | R (AM) |
| Q3005 | 2.1 | 6.0 | 2.8 | | R (CW) |
| Q3006 | 1.3 | 5.1 | 1.9 | | R |
| Q3007 | 1.4 | 3.2 | 2.1 | | R |
| Q3008 | 6.7 | 6.7 | 0.2 | | T |
| Q3009 | 0.5 | 4.8 | 1.2 | | T |
| Q3010 | 0.8 | 0.8 | 1.5 | | R |
| Q3011 | 2.0 | 3.2 | 1.4 | | R |
| Q3012 | 0 | 3.7 | 0 | | R |
| Q3013 | 5.8 | 0 | 3.7 | | R |
| Q3014 | 5.2 | 5.3 | 5.8 | | R |
| Q3015 | 1.4 | 3.2 | 2.0 | | R |
| Q3016 | 0 | 8.0 | 0 | | R |
| Q3017 | 8.0 | 3.7 | 8.0 | | R |
| Q3018 | 5.2 | 14.0 | 3.2 | | R |
| Q3019 | 14.0 | 0 | 14.0 | | R |
| Q3020 | 3.0 | 6.6 | 3.6 | | R |
| Q3021 | 0.7 | 4.2 | 1.4 | | R (FIX ON) |
| Q3023 | 1.8 | 8.1 | 2.4 | | R |
| Q3024 | 1.7 | 8.1 | 2.4 | | R |
| Q3025- Q3035 | 1.3 | 7.2 | 2.0 | | R |
| Q3036 | 1.7 | 4.2 | 2.4 | | R (MARKER ON) |
| Q3038 | 3.2 | 8.1 | 3.5 | | R |
| Q3039 | 0 | 1.5 | 0 | | T |
| Q3040 | 8.0 | 0 | 8.0 | | T |

| | IN | OUT |
|-------|------|-----|
| Q3001 | 14.0 | 8.0 |
| | | R |

| | 1 | 2 | 3 | 4 | 5 |
|-------|-----|-----|---|-----|------|
| Q3022 | 0.7 | 0.7 | 0 | 6.6 | 14.0 |
| | | | | | R |

| | 1 | 2 | 3 | 4 | 5 | 6 | 7 | 8 | 9 | 10 | 11 | 12 | 13 | 14 |
|-------|-----|---|---|---|---|---|---|---|---|----|----|----|----|---------------|
| Q3037 | 4.1 | 0 | - | - | 0 | - | - | - | - | - | - | - | - | 8.1 |
| | | | | | | | | | | | | | | R (MARKER ON) |

BAND 20m
 MODE USB
 RF GAIN MAX
 NB OFF
 ACC SLOW
 MARK OFF

AVR UNIT PARTS LAYOUT(PB-2099A)

VOLTAGE CHART (DC VOLTS)

| | E(S) | C(D) | B(G) |
|-------|------|------|------|
| Q4601 | 13.3 | 14.0 | 13.9 |
| Q4603 | 6.3 | 8.0 | 6.3 |

| | IN | OUT |
|-------|------|-----|
| Q4602 | 14.0 | 8.0 |

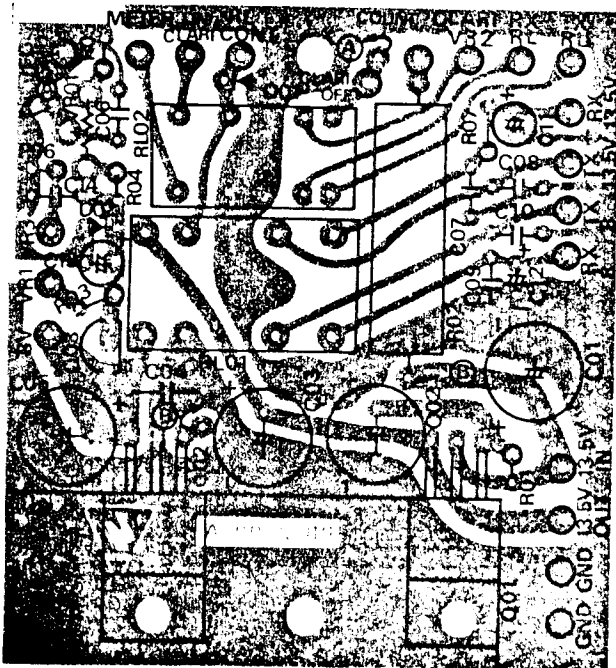
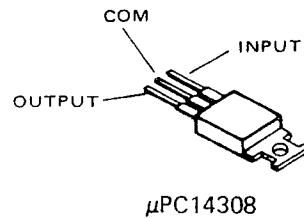
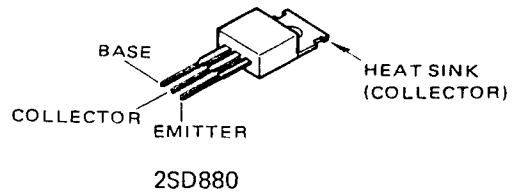
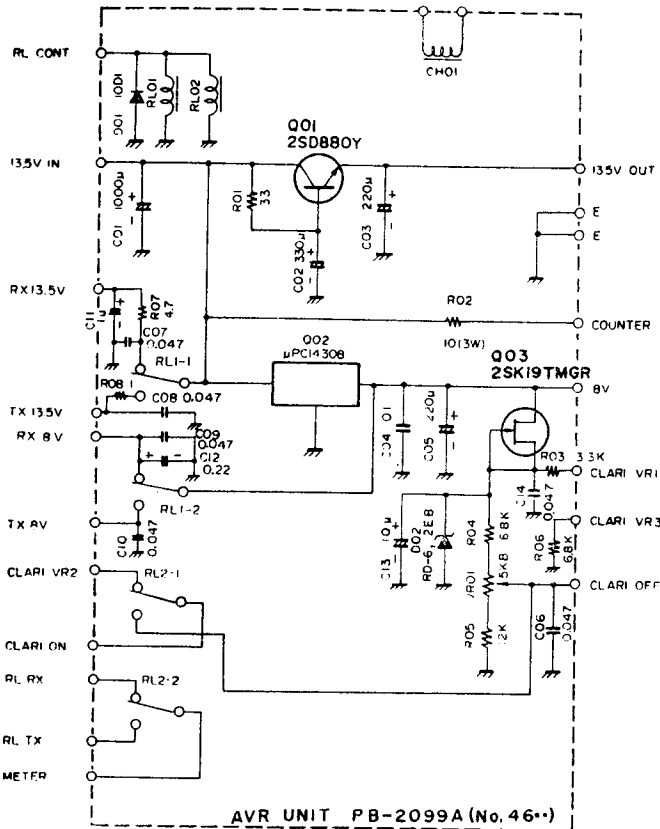

Viewed from component side

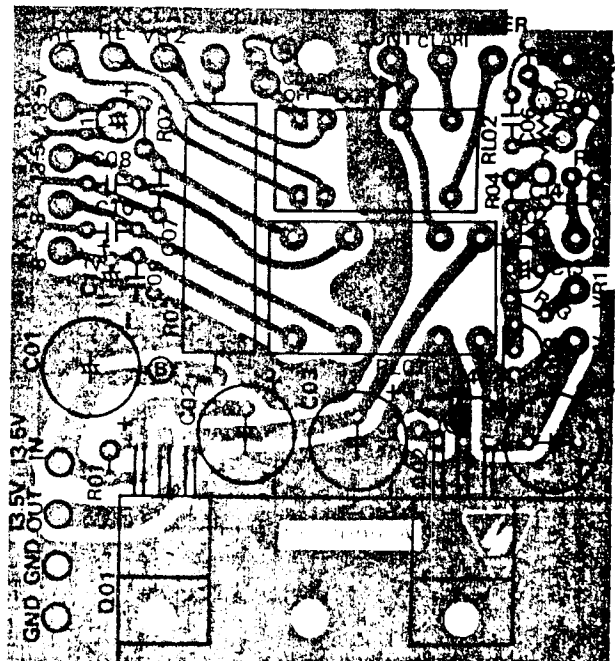

Viewed from foil side

HP5082 - 7623x6

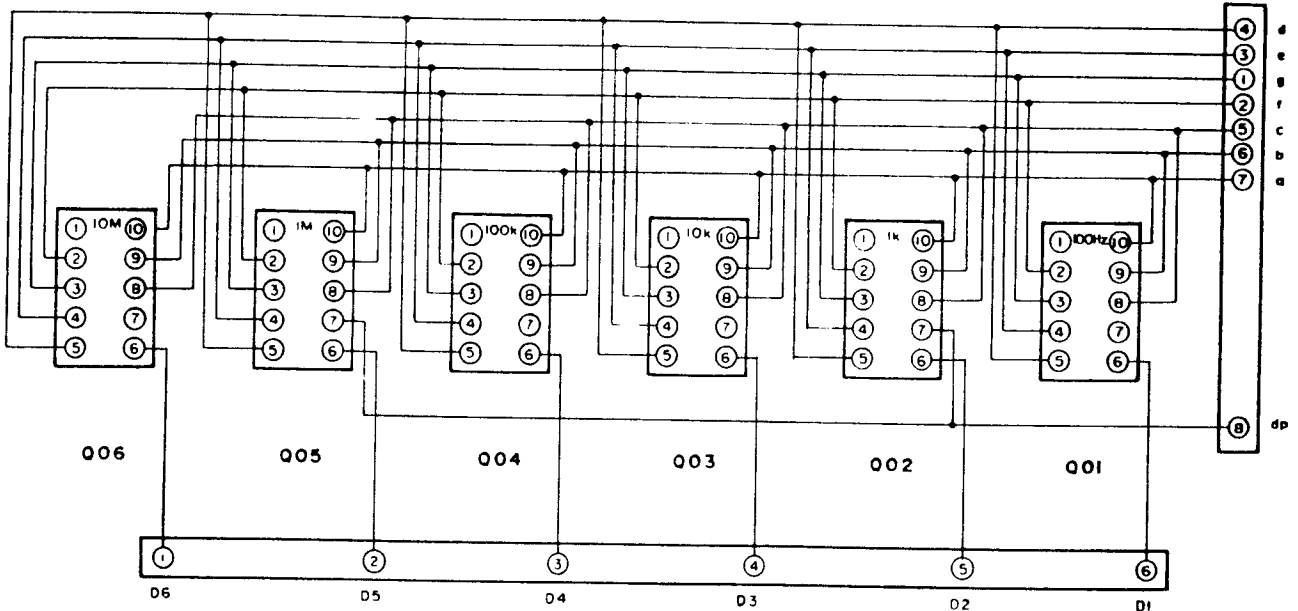

DISPLAY UNIT PB-2098

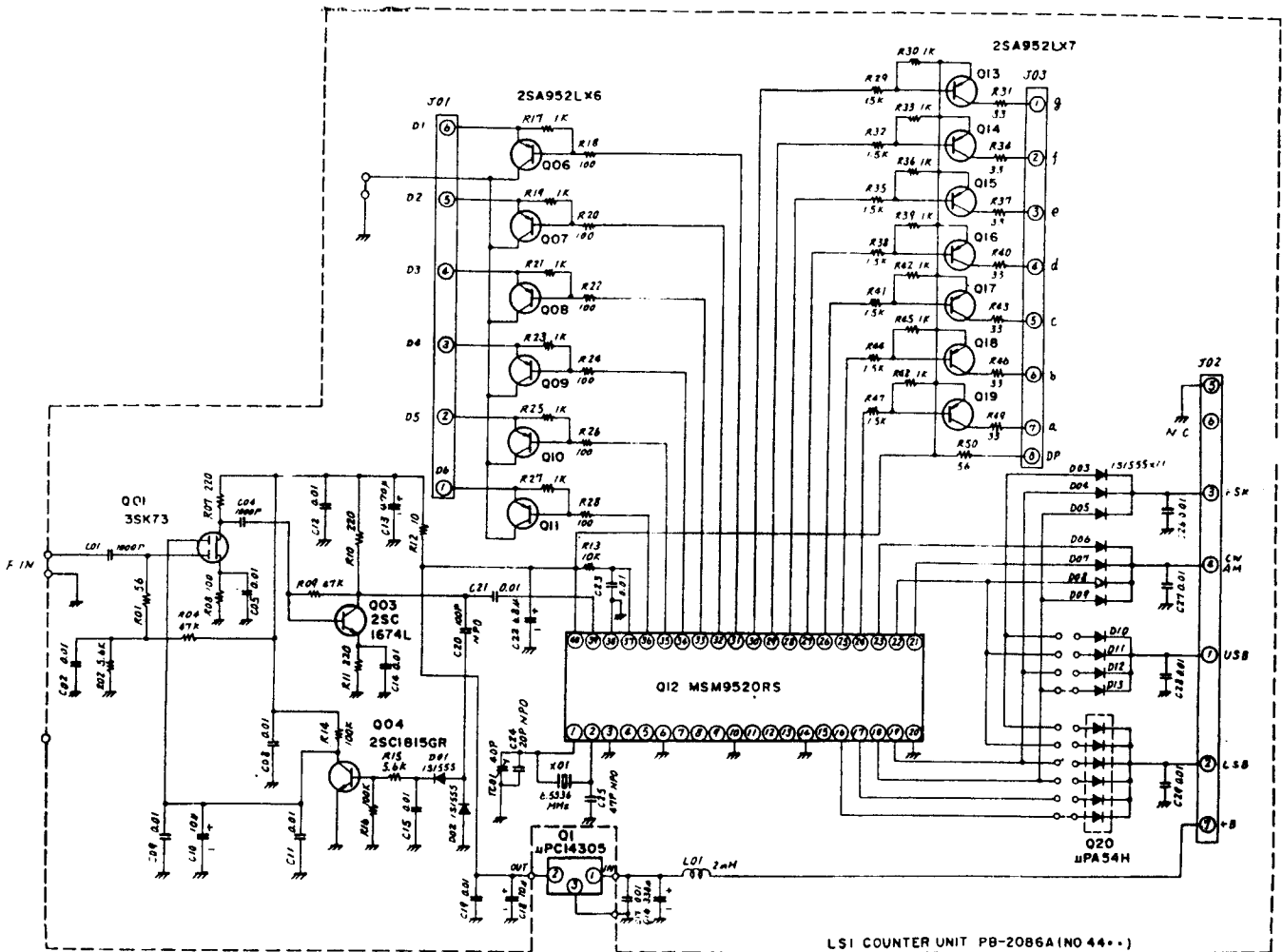

LSI COUNTER UNIT PB-2086A (NO 44..)

VOLTAGE CHART (DC VOLTS)

| | E (S) | | C (D) | | B (G1) | | G2 | |
|-------|-------|---|-------|---|--------|---|-----|---|
| | R | T | R | T | R | T | R | T |
| Q4401 | 0.3 | — | 4.3 | — | 0.5 | — | 4.0 | — |
| Q4403 | 1.0 | — | 4.0 | — | 1.7 | — | — | — |
| Q4404 | 0 | — | 0.4 | — | 0.5 | — | — | — |
| Q4406 | 2.1 | — | 0 | — | 2 | — | — | — |
| Q4407 | 3.4 | — | 0 | — | 3.3 | — | — | — |
| Q4408 | 2.1 | — | 0 | — | 2.0 | — | — | — |
| Q4409 | 2.1 | — | 0 | — | 2.0 | — | — | — |
| Q4410 | 3.4 | — | 0 | — | 3.3 | — | — | — |
| Q4411 | 2.1 | — | 0 | — | 2.0 | — | — | — |
| Q4413 | 5.1 | — | 2.0 | — | 4.9 | — | — | — |
| Q4414 | 5.1 | — | 4.4 | — | 4.6 | — | — | — |
| Q4415 | 5.1 | — | 4.0 | — | 4.6 | — | — | — |
| Q4416 | 5.1 | — | 4.4 | — | 4.6 | — | — | — |
| Q4417 | 5.1 | — | 4.4 | — | 4.6 | — | — | — |
| Q4418 | 5.1 | — | 4.0 | — | 4.6 | — | — | — |
| Q4419 | 5.1 | — | 4.4 | — | 4.6 | — | — | — |

DISPLAY
5.000.0

| | IN | COM | OUT |
|----|------|-----|-----|
| Q1 | 11.2 | 0 | 5.0 |

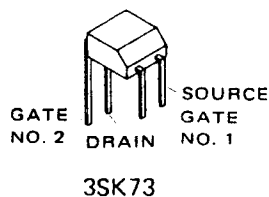
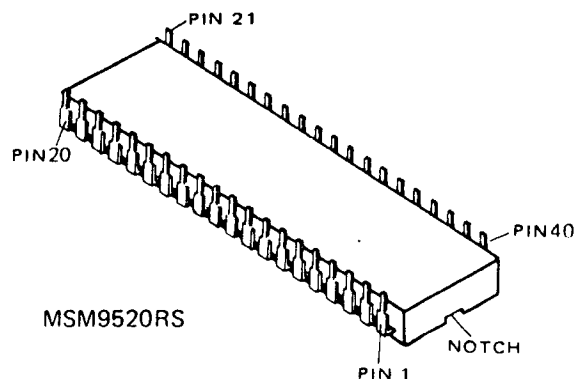
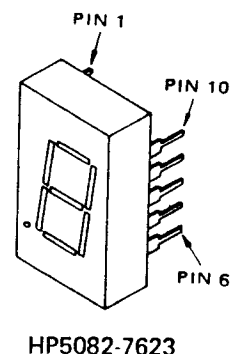
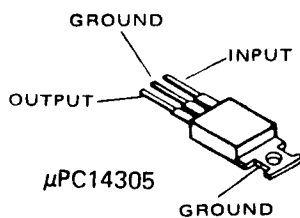
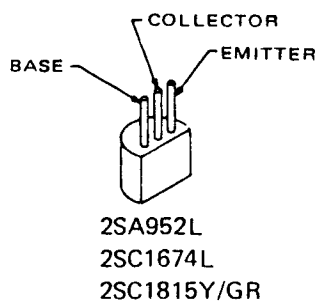

COUNTER UNIT PARTS LAYOUT

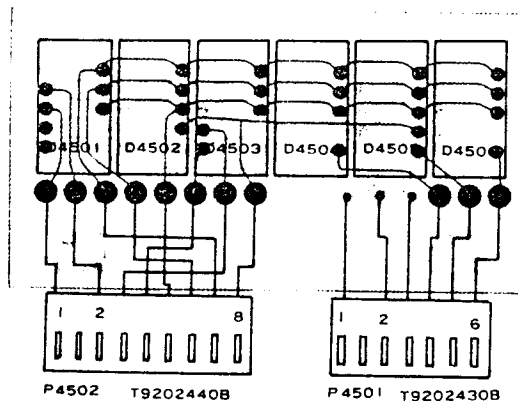

MAIN BOARD

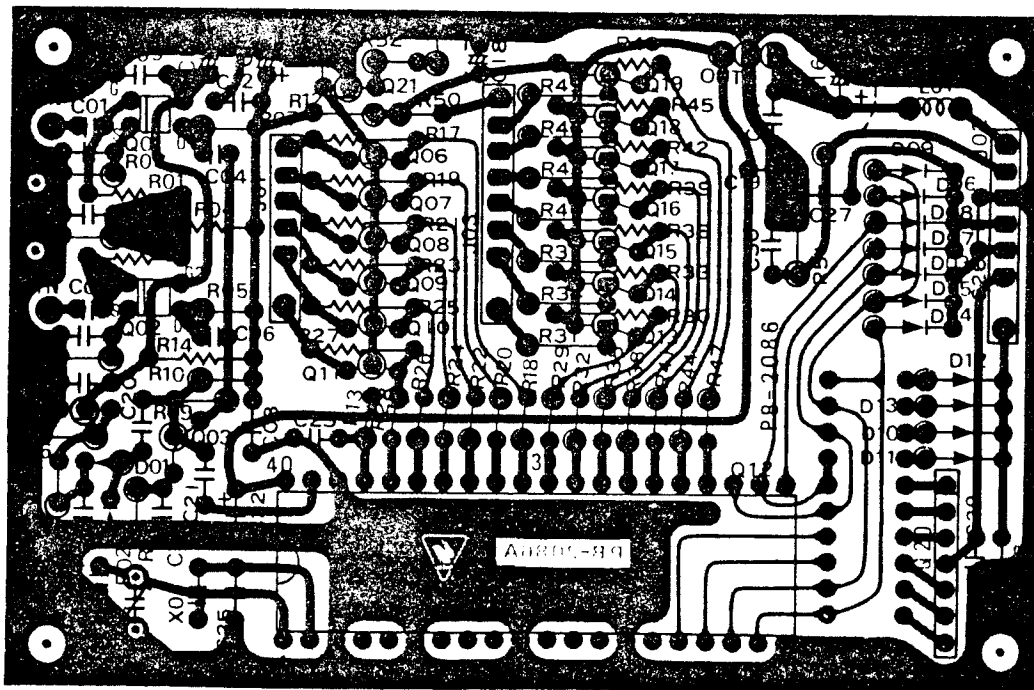

Viewed from component side

- Not used
- Q4402 C2303
 - R2303 C2306
 - R2305 C2307
 - R2306

COUNTER UNIT PARTS LAYOUT

SERVICING

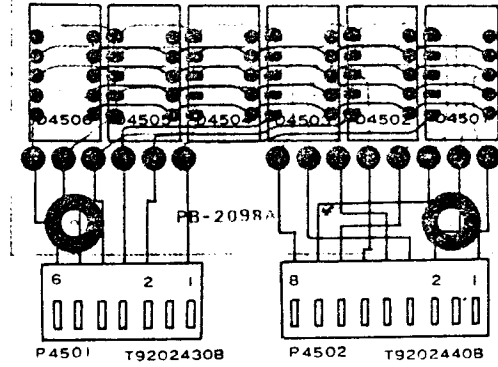

MAIN BOARD

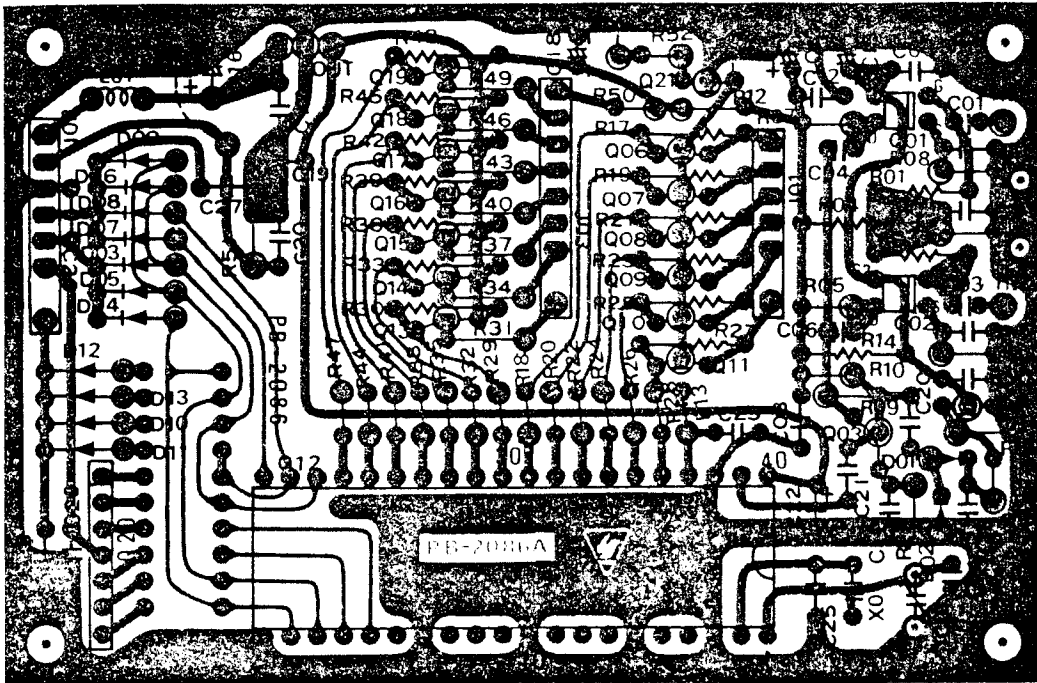

Viewed from foil side

VFO ASSEMBLY VFO UNIT(PB-2097A)

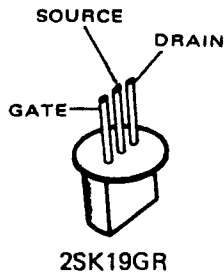
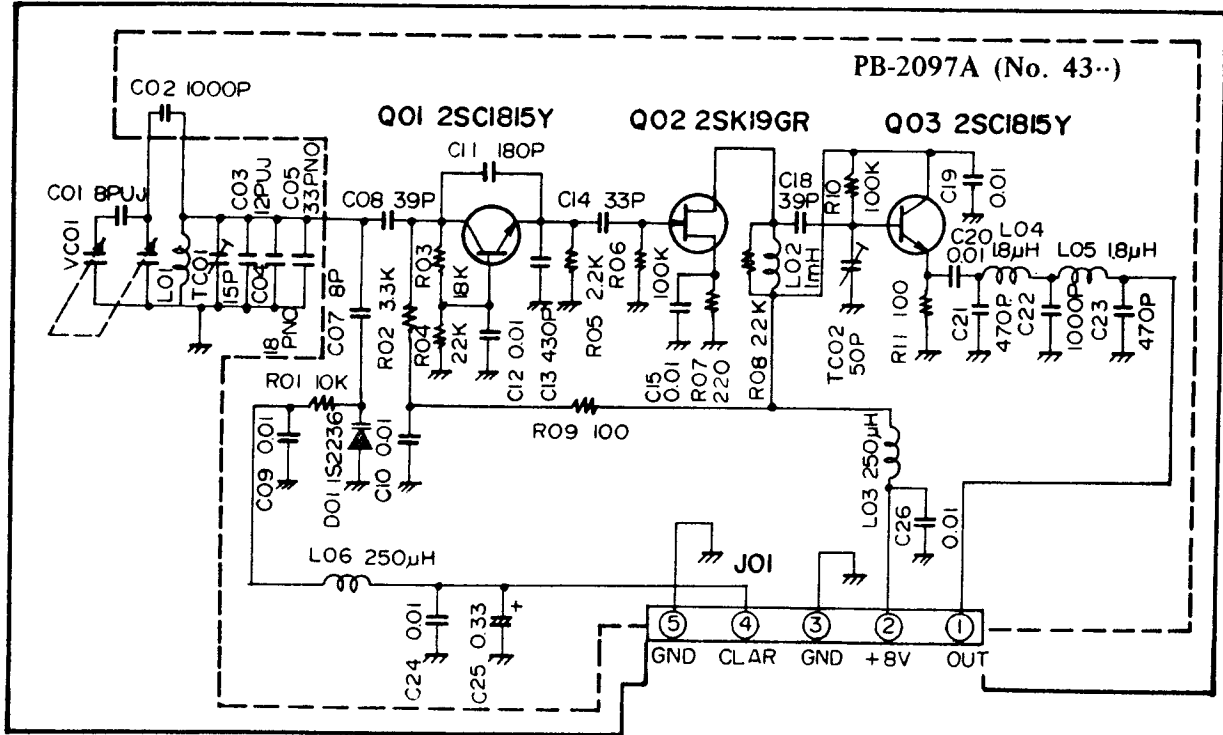

VOLTAGE CHART
(DC VOLTS)

| | E(S) | C(D) | B(G) |
|-------|------|------|------|
| Q4301 | 1.4 | 3.7 | 1.9 |
| Q4302 | 0.9 | 6.0 | 0 |
| Q4303 | 0.9 | 6.0 | 1.6 |

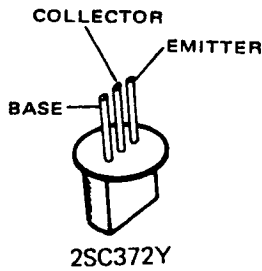

VFO UNIT PARTS LAYOUT (PB-2097A)

SERVICING

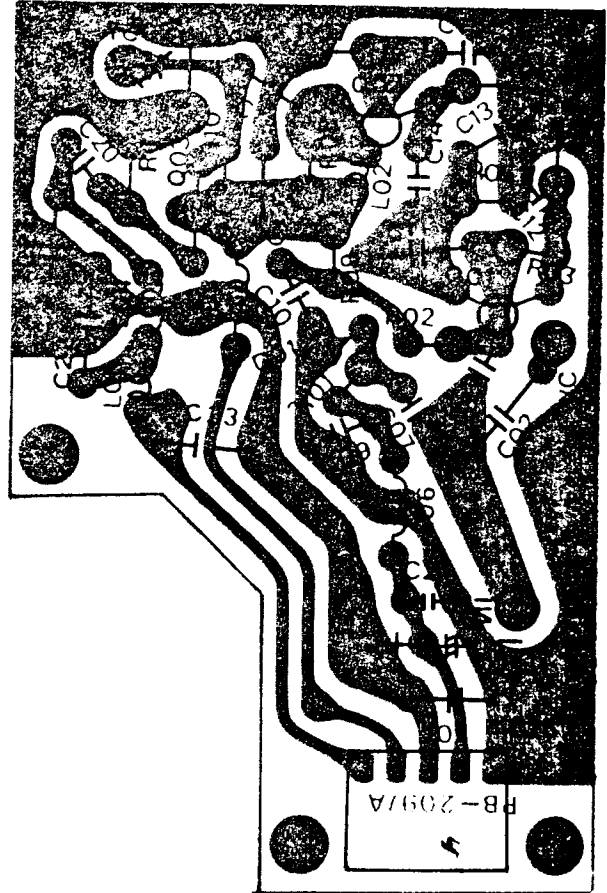
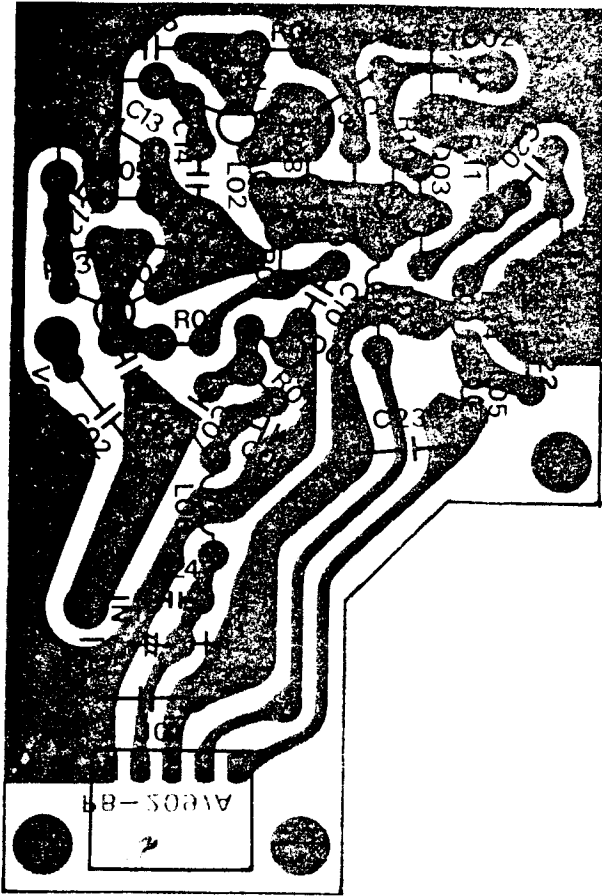

VFO UNIT EXPLODED VIEW

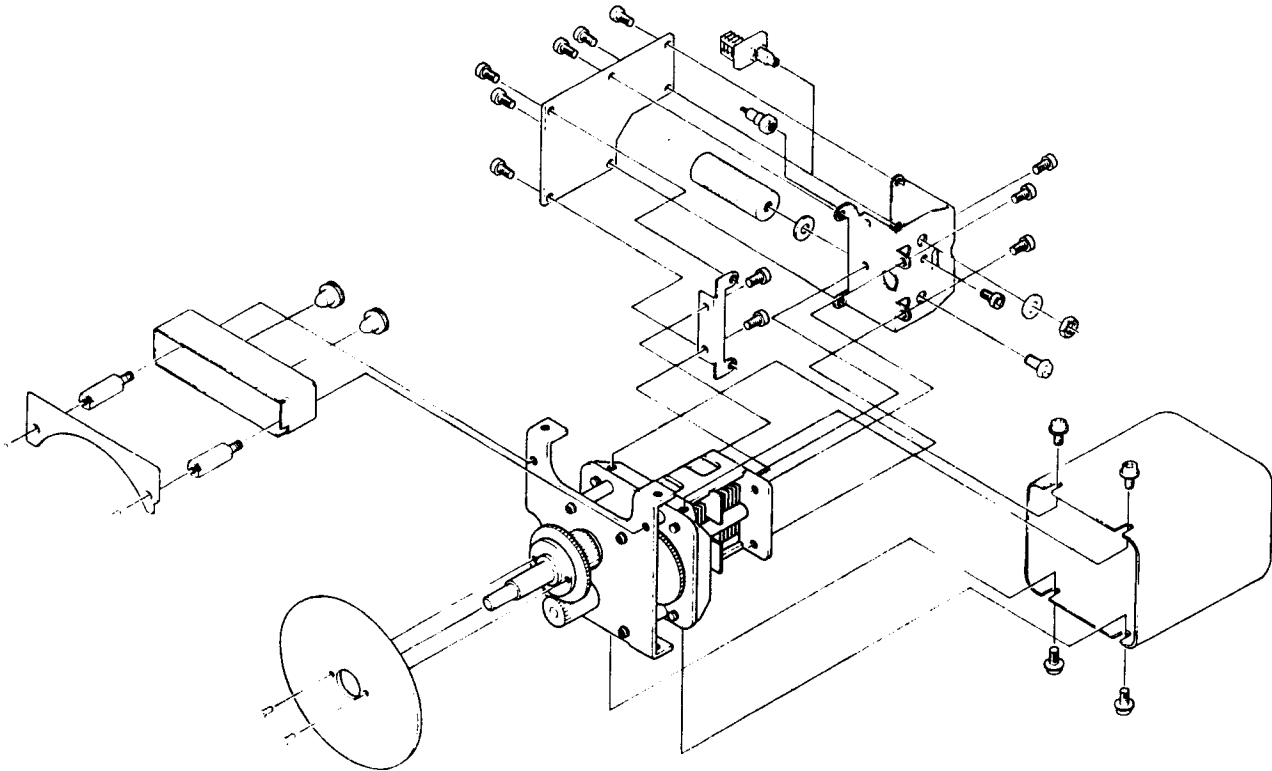

LPF UNIT PARTS LAYOUT (PB-2128)

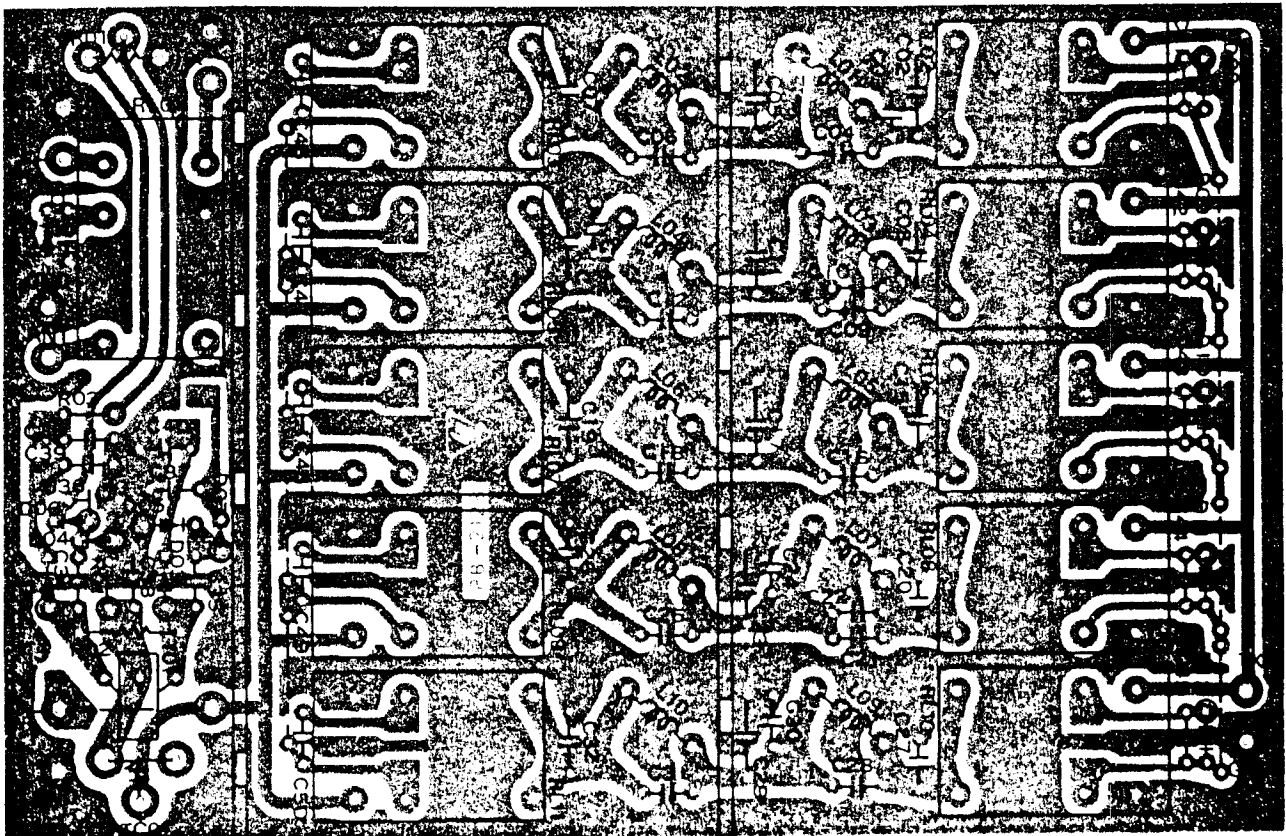
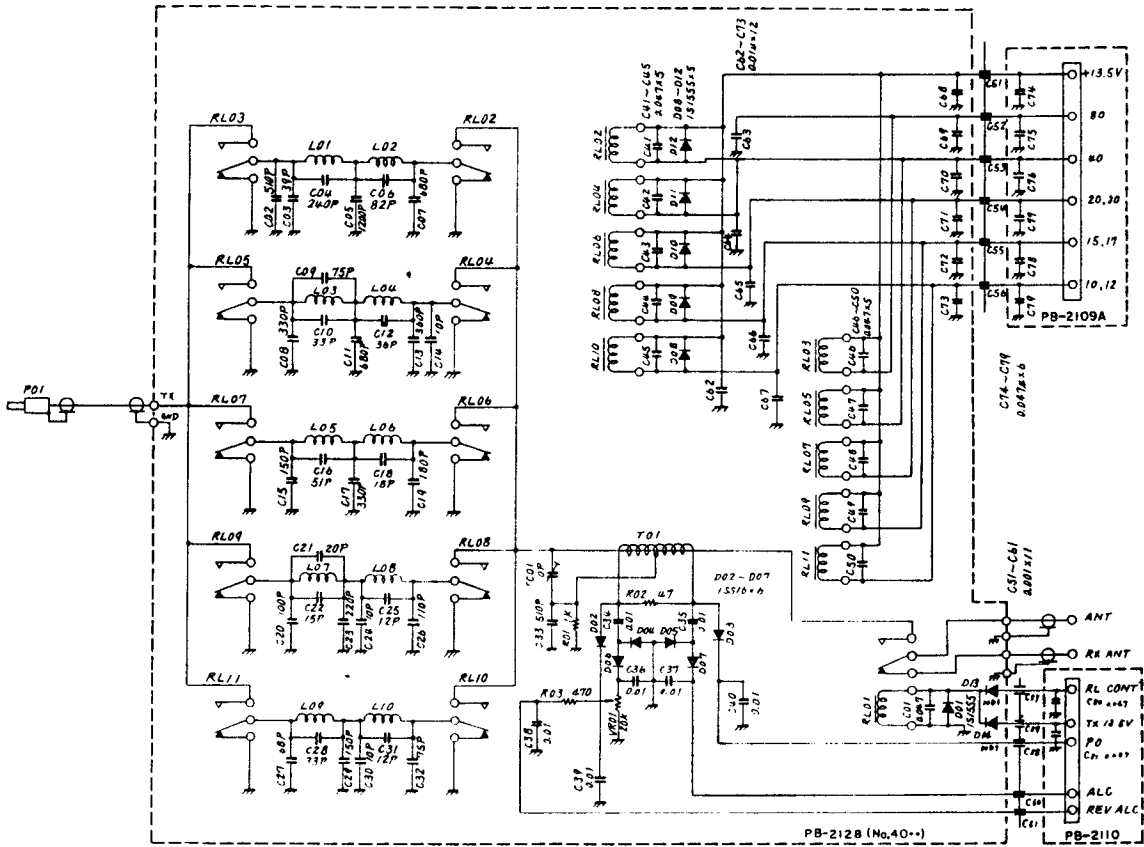

Viewed from foil side

LPF UNIT MOUNTING DETAIL

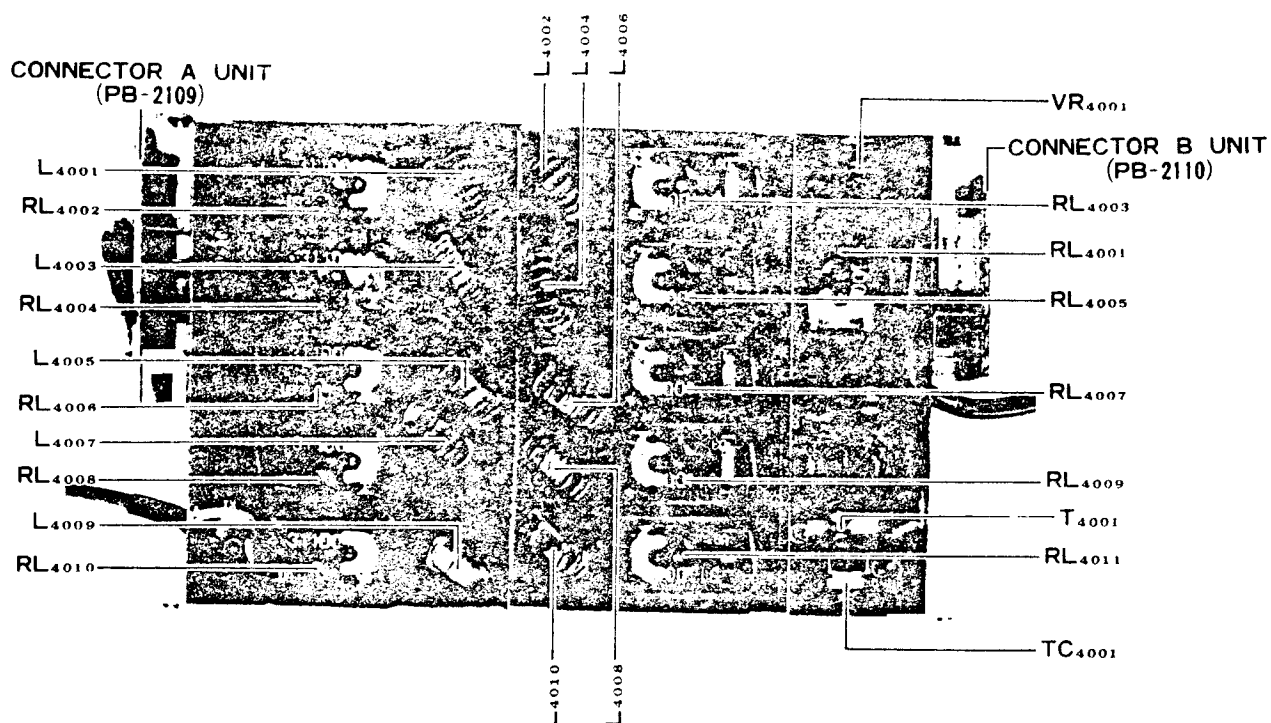

RELAY CONNECTIONS RL4001-4011 (FBR311D012)

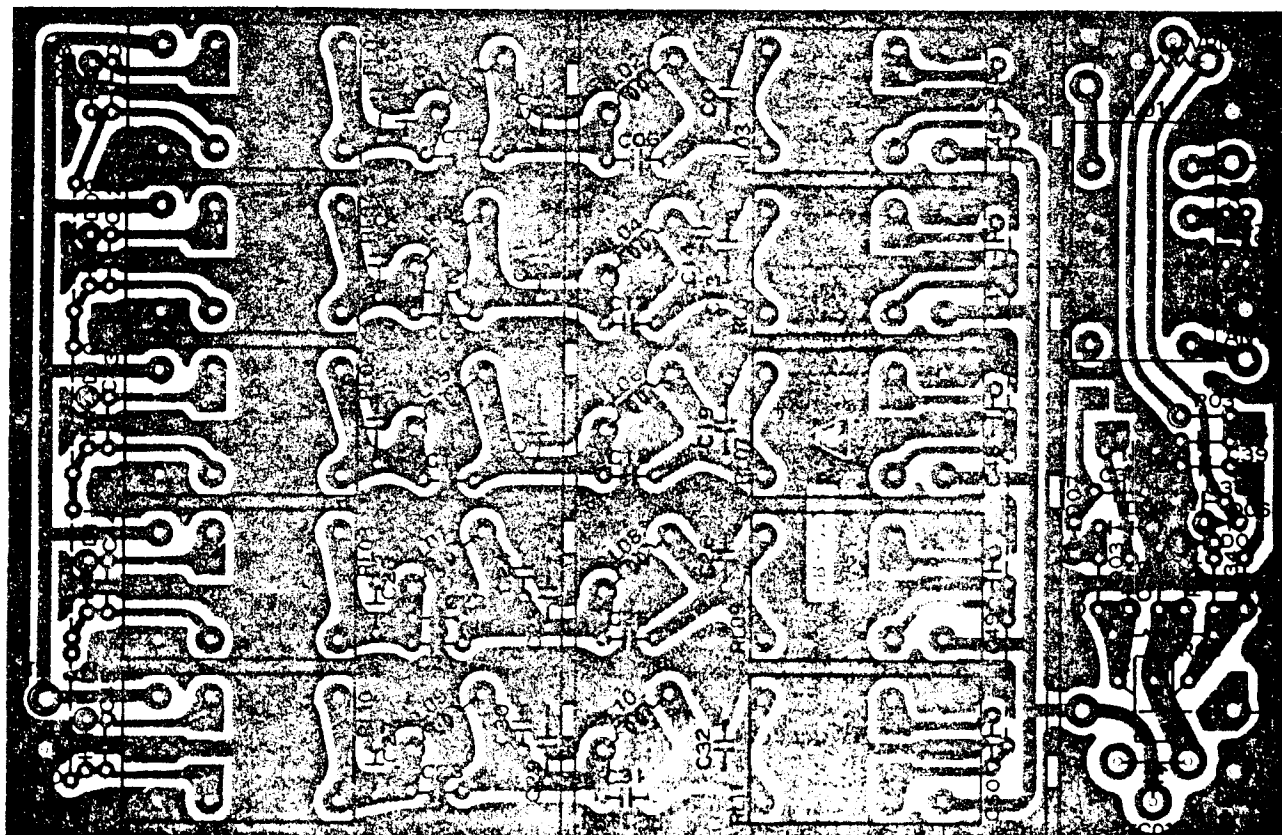
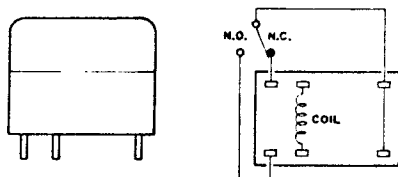

Viewed from component side

100W PA UNIT (PB-2013)

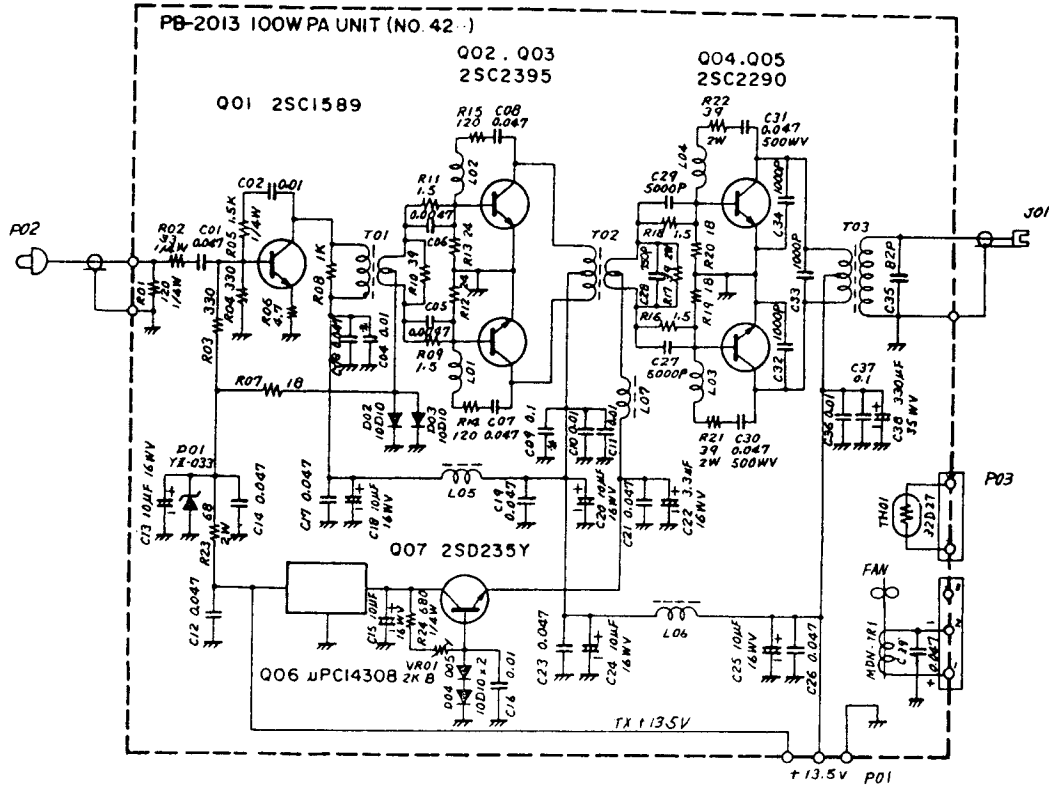

| | E | C | B |
|-------------|-----|------|-----|
| Q4201 | 0.5 | 13.5 | 1.3 |
| Q4202, 4203 | 0 | 13.5 | 0.7 |
| Q4204, 4205 | 0 | 13.5 | 0.7 |
| Q4207 | 0.7 | 8.0 | 1.3 |

| | IN | COM | OUT |
|-------|------|-----|-----|
| Q4206 | 13.5 | 0 | 8.0 |

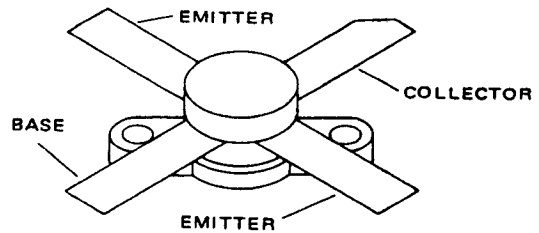

2SC2290
2SC2395

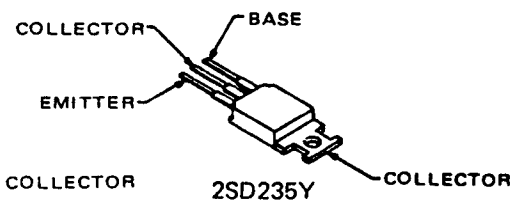
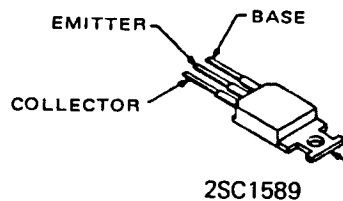
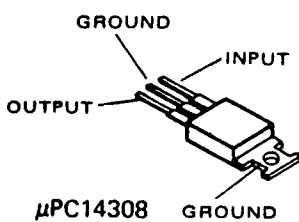

100W PA UNIT PARTS LAYOUT

SERVICING

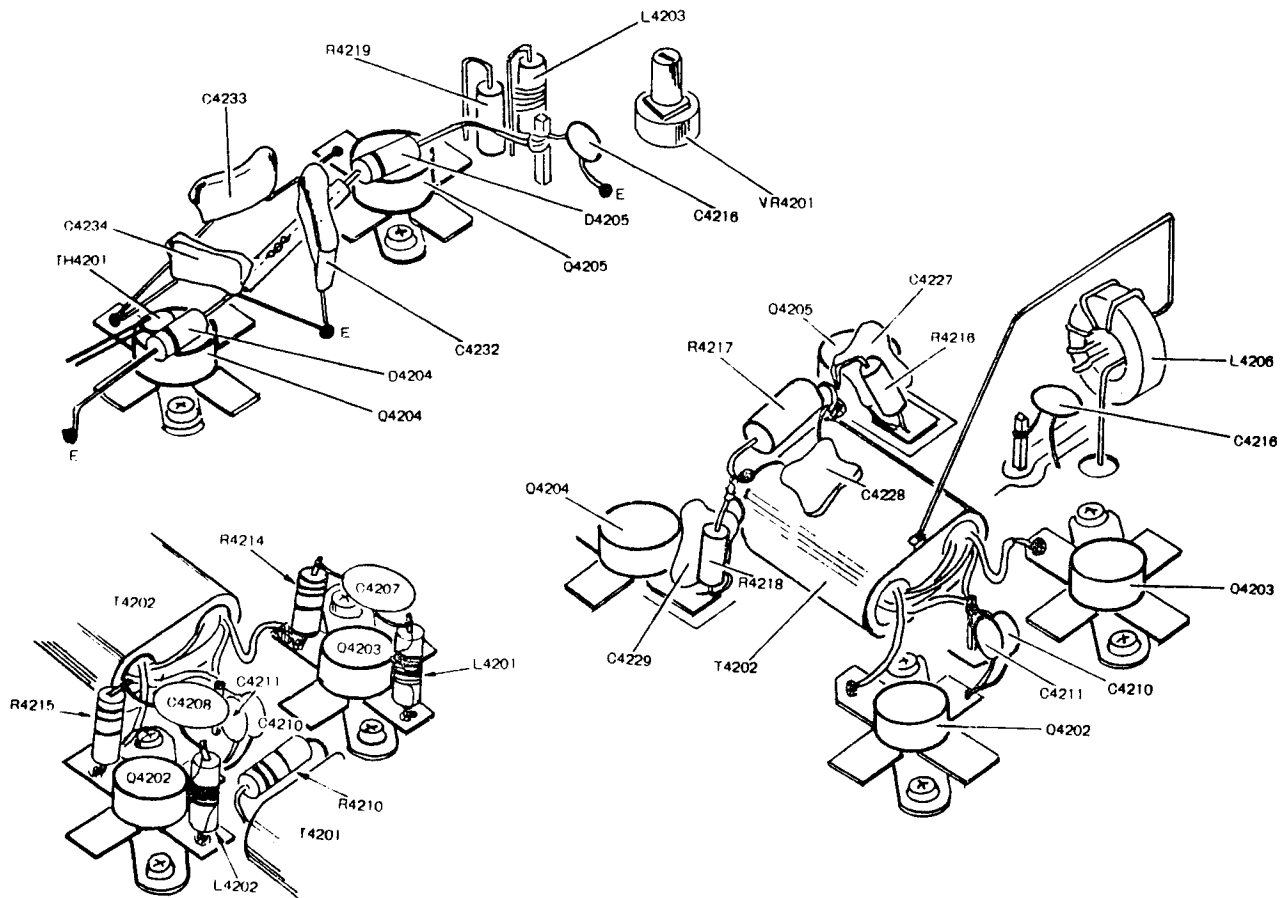
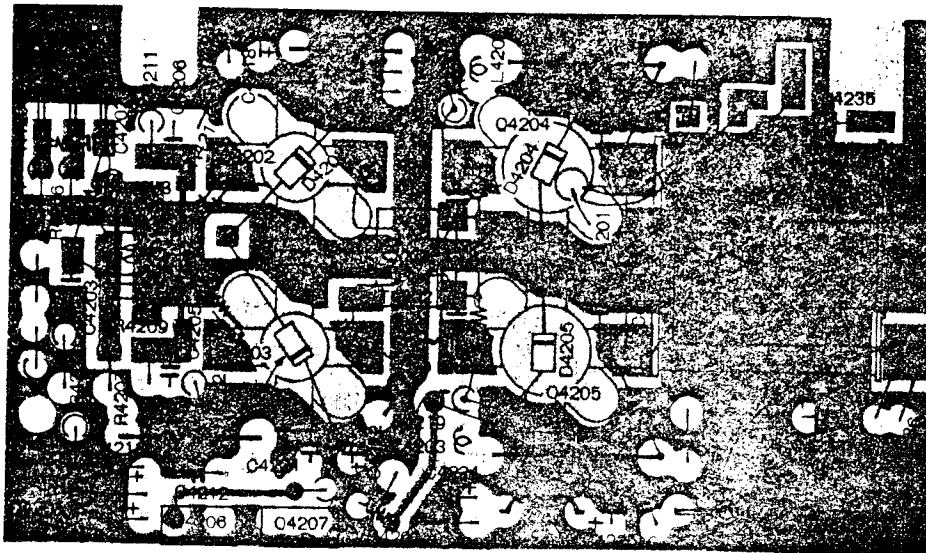

100W PA UNIT ASSEMBLY

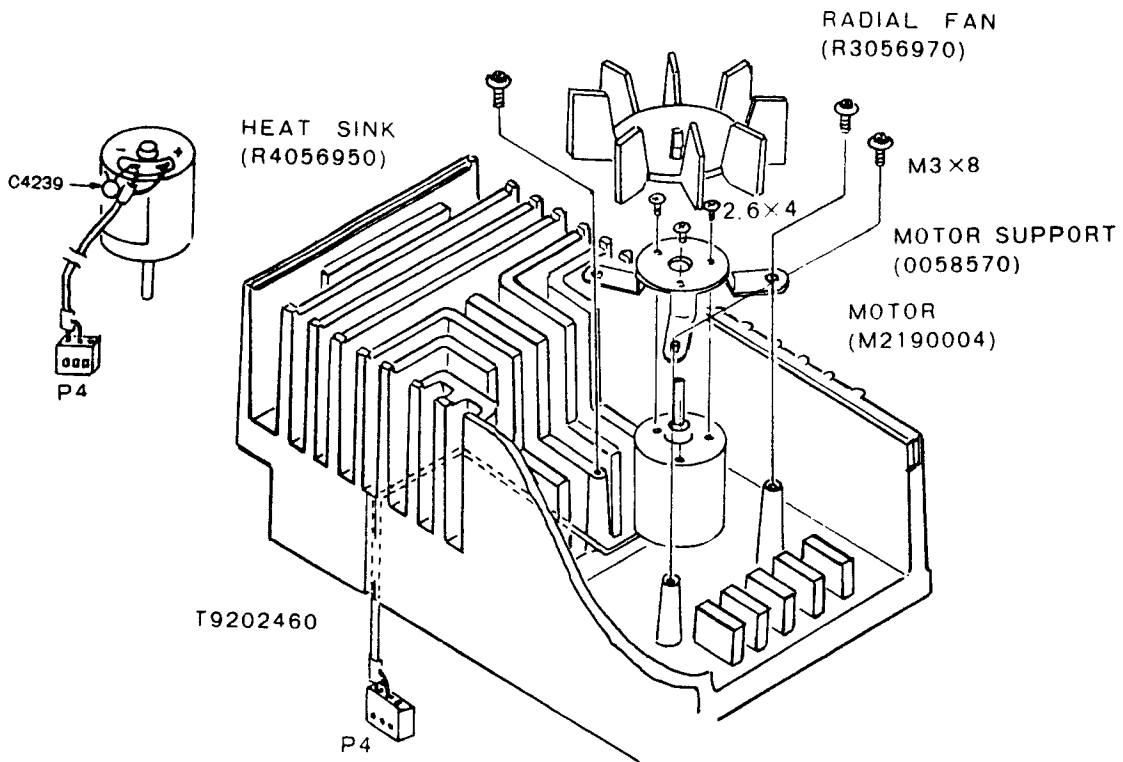
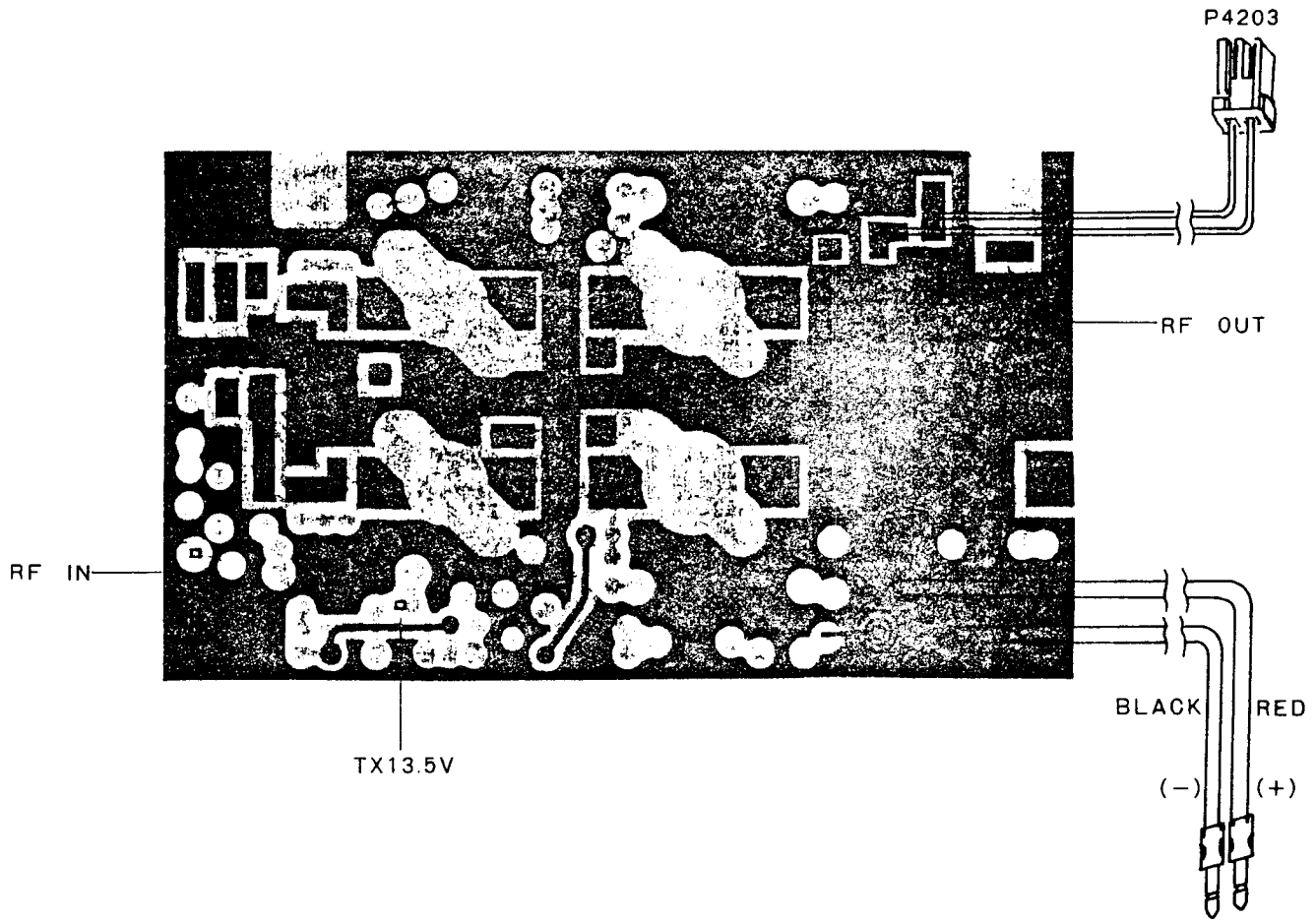

HPF/FAN MOTOR CONTROL UNIT PARTS LAYOUT (PB-2101)

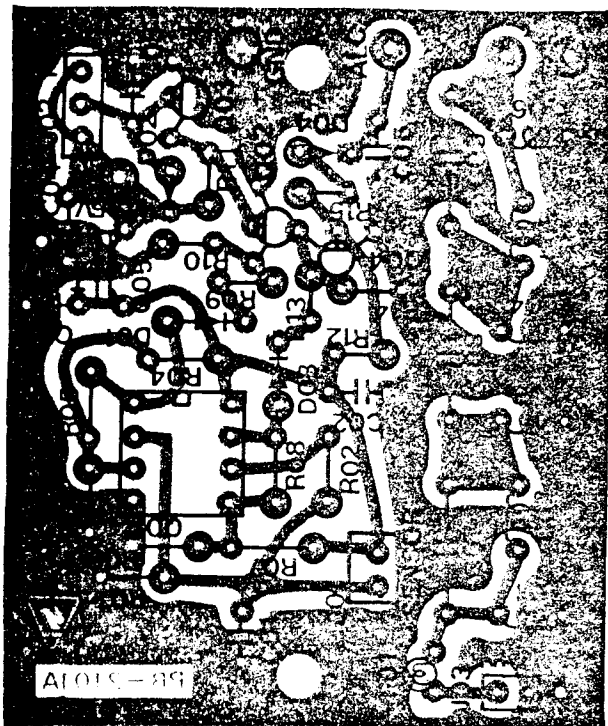

Viewed from component side

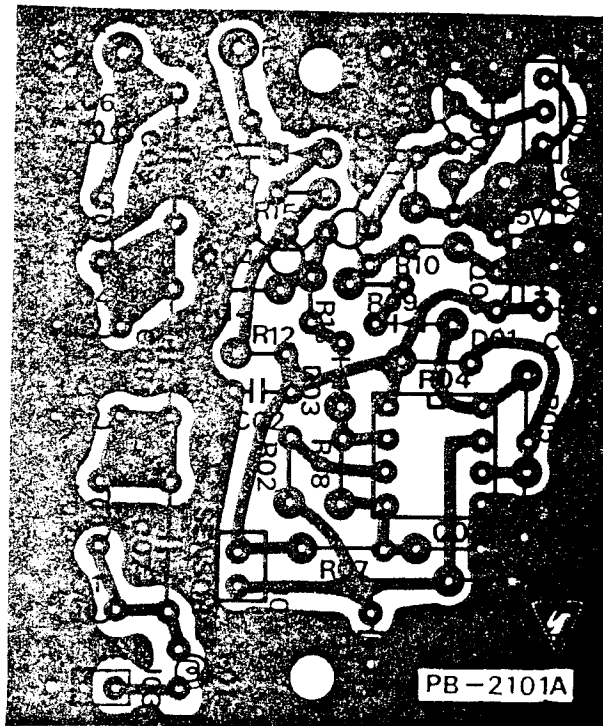

Viewed from foil side

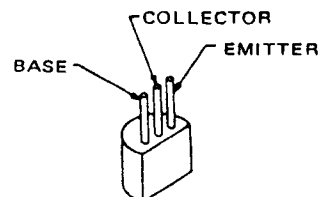
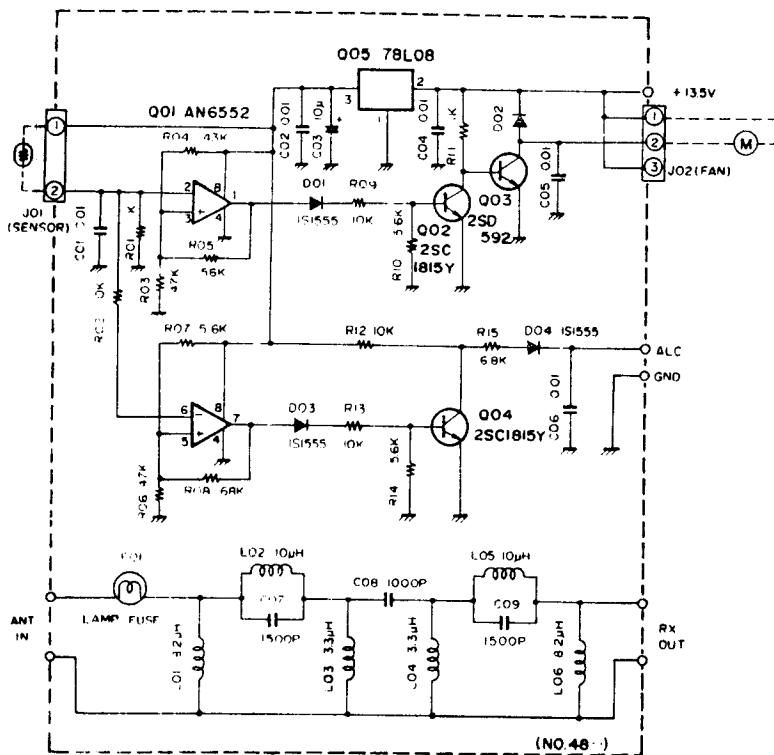

2SC1815Y
2SD592

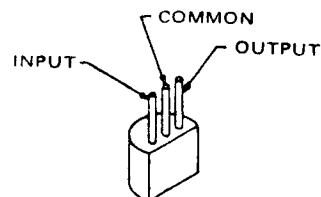

μPC78L05

| | | | | | | | | |
|-------|-----|-----|-----|---|-----|-----|-----|-----|
| | 1 | 2 | 3 | 4 | 5 | 6 | 7 | 8 |
| Q4801 | 1.3 | 4.9 | 3.3 | 0 | 7.1 | 4.9 | 7.1 | 7.9 |

| | | | |
|-------|---|-----|-----|
| | E | C | B |
| Q4802 | 0 | 0.7 | 0.3 |
| Q4803 | 0 | 0 | 0.7 |
| Q4804 | 0 | 0.6 | 0.7 |

| | | |
|-------|------|-----|
| | IN | OUT |
| Q4805 | 14.2 | 8.0 |

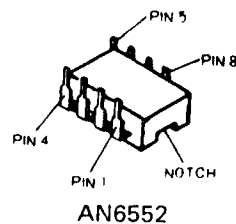

LEVEL METER(INDICATOR)UNIT PARTS LAYOUT(PB-2100)

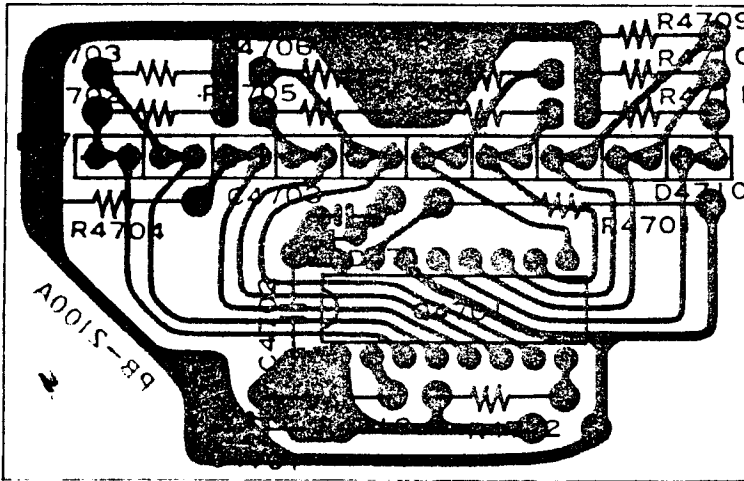
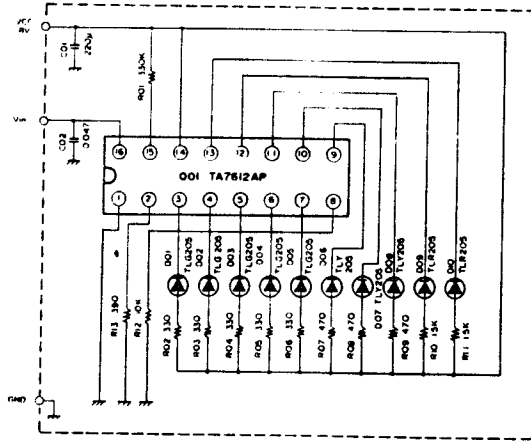

Viewed from component side

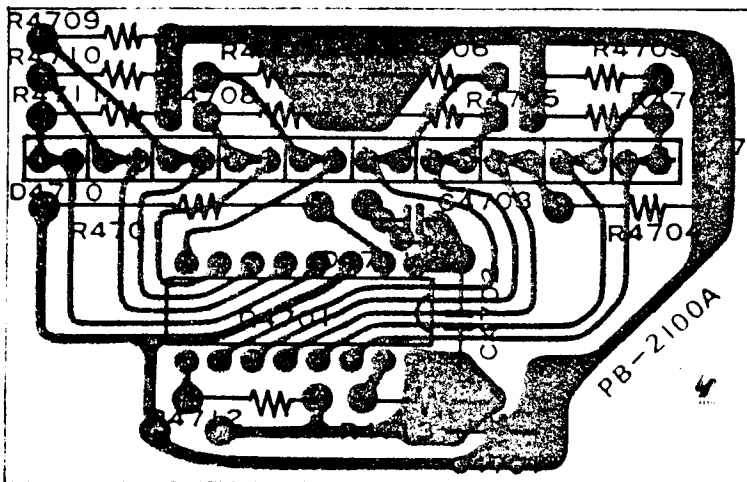
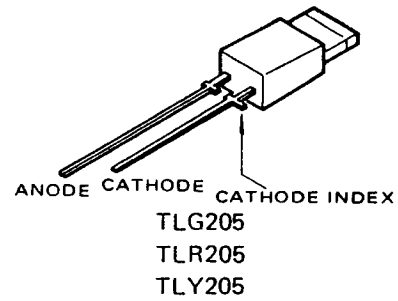

Viewed from foil side

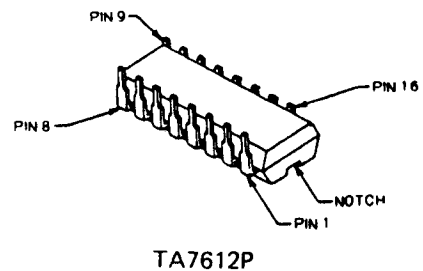

SW UNIT PARTS LAYOUT(PB-2102)

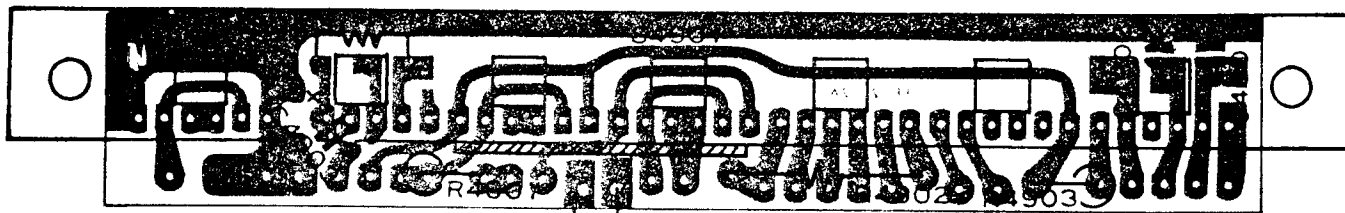
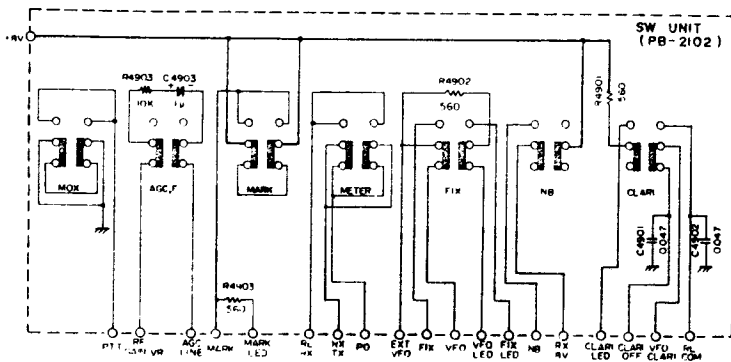

Viewed from SW side

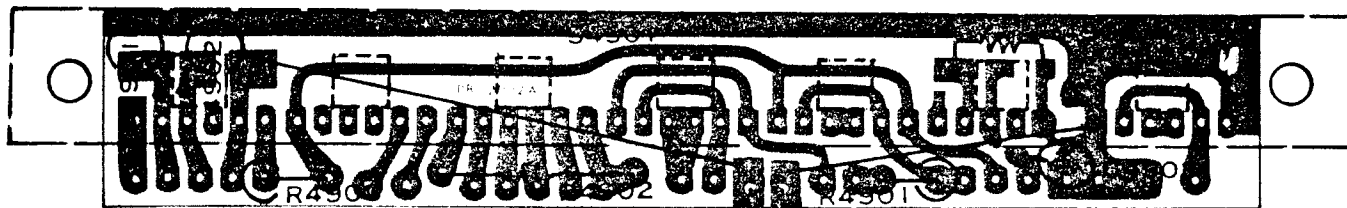

Viewed from foil side

VR UNIT A/B (PB-2103A)

VR UNIT B



DELAY TIME CONTROL

VR UNIT A



VOX GAIN CONTROL

SWITCH ASSEMBLIES

BAND SWITCH ASSEMBLY

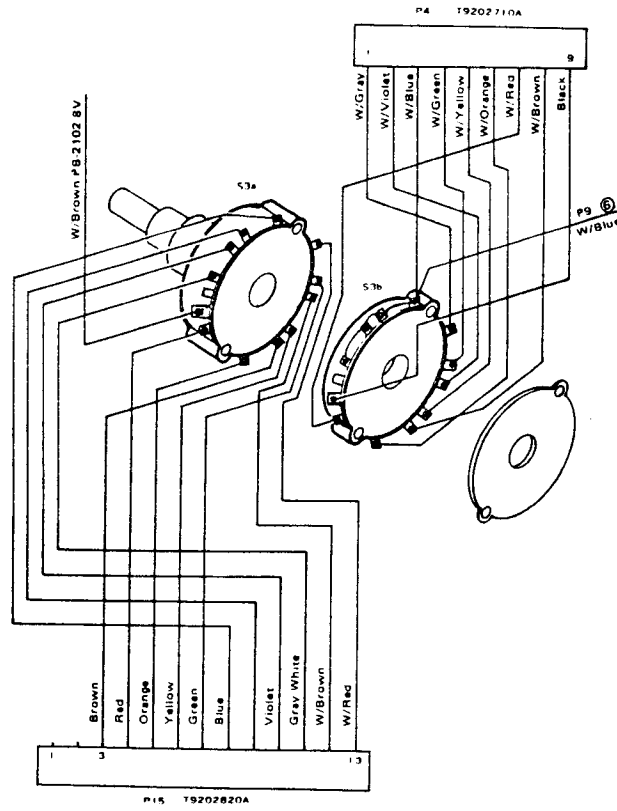

MODE SWITCH ASSEMBLY

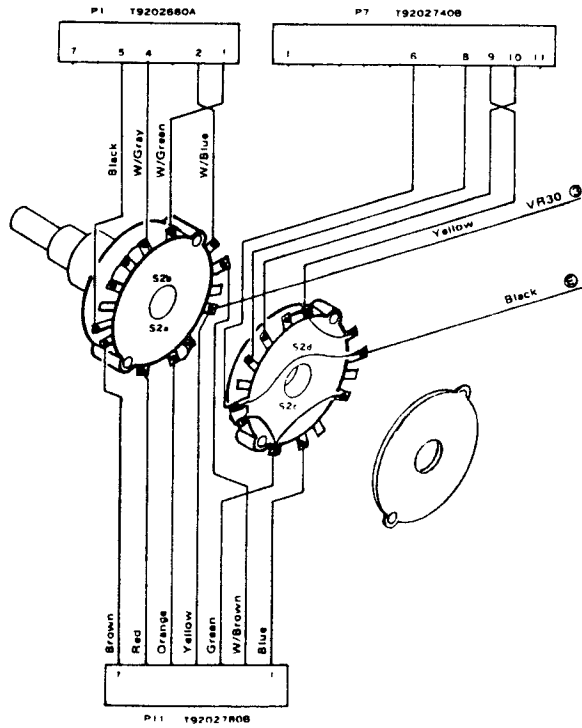

POTENTIOMETER ASSEMBLIES

SERVICING

MIC GAIN/CARRIER CONTROL ASSEMBLY

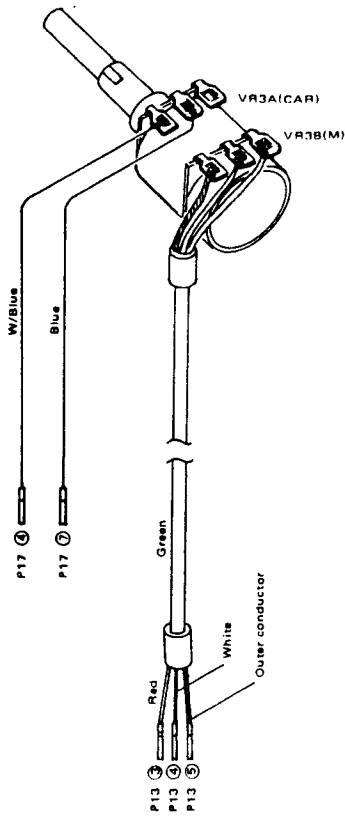

RF/AF GAIN CONTROL ASSEMBLY

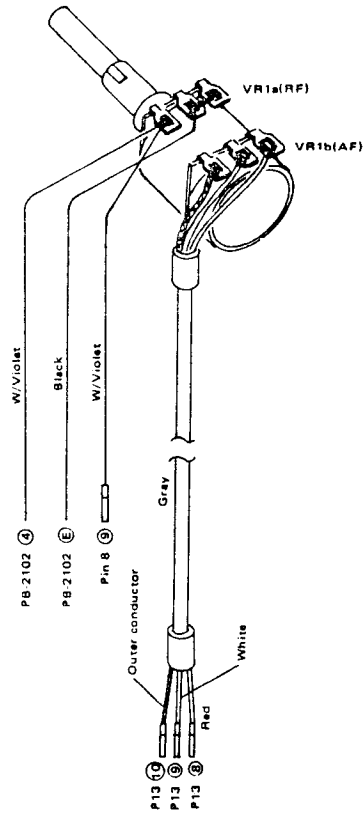

CLARIFIER/BAND WIDTH CONTROL ASSEMBLY

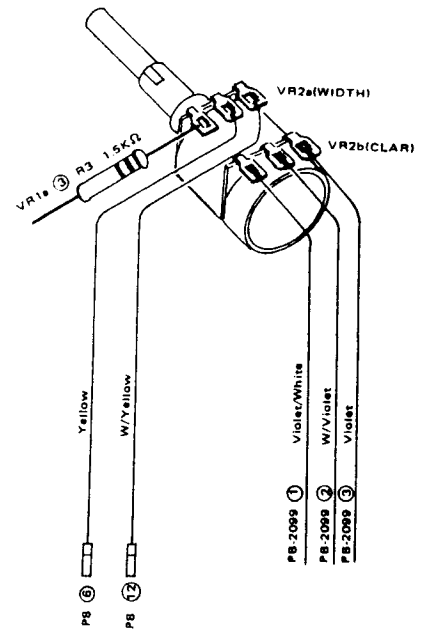

MEMO

SECTION 4—REPAIR PARTS

| | |
|------------------------------------|-----|
| PARTS LIST AND ORDERING DATA | 4-1 |
| PARTS LIST | 4-5 |

PARTS LIST AND ORDERING DATA

If you live in the United States, you may order parts from Yaesu Electronics Corporation. In other countries, you should order parts from the Yaesu agent for your country. In countries where Yaesu is not currently represented, you may order spare parts directly from Yaesu Musen Company, Ltd. in Tokyo.

When ordering, please specify the exact model number of the transceiver that the part is for. Many parts are standard, such as resistors and disc ceramic capacitors, but you should use particular care when ordering such items as electrolytics, tantalum capacitors, and the like.

The parts list to follow identifies the board that the parts belong to, as well as the circuit designation and part description. A "Part Number" is also specified, and this number will allow immediate identification by our parts department of the item you require. (*See note below.)

Shipment of parts from Yaesu USA is usually made by UPS, COD. Allow at least a week for the parts department to process your order.

PARTS ORDER EXAMPLE

| QUANTITY | TRANSCIVER IDENTIFICATION | LOCATION | *PART NUMBER | CIRCUIT DESIGNATION |
|----------|---------------------------|----------|--------------|---------------------------|
| 1 | FT-707 | PB-2093A | G4800730G | Q ₁₀₀₁ 3SK73GR |

(cut here)

YAESU MUSEN COMPANY, LTD. – C.P.O. BOX 1500, TOKYO, JAPAN
 YAESU ELECTRONICS CORPORATION – 6851 Walthall Way, Paramount, CA 90723
 YAESU ELECTRONICS CORPORATION – 9812 Princeton-Glendale Rd., Cincinnati, OH 45246

ORDER BLANK

| QUANTITY | TRANSCIVER IDENTIFICATION | LOCATION | PART NUMBER | CIRCUIT DESIGNATION |
|----------|---------------------------|----------|-------------|---------------------|
| | | | | |
| | | | | |
| | | | | |
| | | | | |
| | | | | |
| | | | | |
| | | | | |

I authorize shipment via: Best Way Parcel Post
 UPS Other

Ship To: Name: _____
 (Print or Type) Address: _____
 City: _____ State: _____ Zip: _____
 Country: _____

PARTS LIST

REPAIR PARTS

| MAIN CHASSIS | | | | | | PLUG | |
|--------------|-----------|-------------------------------|----------------------|--|-----------|-----------------------|----------------------|
| Symbol No. | Part No. | Description | | P1 | P1090074 | 5047-07A | |
| | | | | P10 | P1090153 | PI051-04F | |
| | | IC | | P16,18 | P1090154 | PI051-05F | |
| Q1 | G1090065 | | μ PC14305 | P2,3,9,14,19 | P1090155 | PI051-06F | |
| Q2 | G1090070 | | μ PC14308 | P11,12 | P1090156 | PI051-07F | |
| | | | | P4,5 | P1090158 | PI051-09F | |
| | | DIODE | | P17 | P1090159 | PI051-10F | |
| D1,2 | G2090001 | Si | 10D1 | P7,13 | P1090160 | PI051-11F | |
| D3 | G2090142 | LED | TLR-226 | P6,8 | P1090161 | PI051-12F | |
| | | | | P15 | P1090162 | PI091-13F | |
| | | RESISTOR | | P21 | P1090186 | 3021-03A | |
| R4 | J01245560 | Carbon film | 1/4W TJ 56 Ω | | | | |
| R8 | J01245680 | " " | " " 68 Ω | | S6000060 | Speaker terminal | |
| R7 | J01245151 | " " | " " 150 Ω | | | | |
| R3 | J01245152 | " " | " " 1.5k Ω | | | | |
| R6 | J10276479 | " composition | | | | | |
| | | | 1/2W GK 4.7 Ω | | | | |
| R1 | J10276100 | " " " " | 10 Ω | | | | |
| R2 | J10276101 | " " " " | 100 Ω | | | | |
| | | | | RE UNIT | | | |
| | | | | Symbol No. | Part No. | Description | |
| | | POTENTIOMETER | | PB-2093B | C0020930 | PCB with Components | |
| VR1 | J62800043 | DM10A668A-5KB-5KA | | | F0002093B | Printed Circuit Board | |
| VR2 | J62800044 | DM10E572A-5KBX2 | | | | | |
| VR3 | J62800045 | DM10A667A-5KA-5KB | | | | | |
| VR4 | J60800069 | DM10A624C-20KB | | Q1006 | G1090062 | IC | SN76514N |
| | | | | Q1008 | G2090135 | Diode Quad | ND487C2-3R |
| | | CAPACITOR | | Q1001,1002 | G4800730 | FET | 3SK73GR |
| C2 | K13170103 | Ceramic | 50WV 0.01 μ F | Q1013 | G3303800Y | TR | 2SC380TM-Y |
| C3,4 | K13170473 | " " | " 0.047 μ F | Q1005,1007 | G3318150Y | " | 2SC1815Y |
| C1 | K40120338 | Electrolytic | 25WV 3300 μ F | Q1010,1011 | G3319230R | " | 2SC1923R |
| | | | | Q1004 | G3319590Y | " | 2SC1959Y |
| | | | | Q1009,1012 | G3324070 | " | 2SC2407 |
| | | | | Q1003 | G3090010 | " | 2N4427 |
| | | | | | | | |
| | | SPEAKER | | | | DIODE | |
| SP1 | M4090027 | 4 Ω 3W | SS70 | D1001-1003, 1005,1007, 1009,1011, 1013,1015, 1017, 1019-1021, 1027,1029, 1031,1033, 1035,1037, 1039,1041, 1042-1061, 1070,1071, 1072 | G2090027 | Si | 1SS53 |
| | | INDUCTOR | | | | | |
| L1 | L1190001 | | 250 μ H | | | | |
| | | CHOKE COIL | | | | | |
| CH1 | L2030017 | | 1.7mH | | | | |
| | | RELAY | | | | | |
| RL1 | M1090010 | FRL-263D012/02CK-0E | | | | | |
| | | SWITCH | | | | | |
| S1 | N2090024 | 8H2011 (without Switch Lever) | | | | | |
| S2 | N0190014 | SRN2045N | | D1062-1069 | G2090001 | Si | 10D1 |
| S3 | N0190001 | SRN202CN | | D1004,1006, 1008,1010, 1012,1014, 1016,1018, 1022-1025, 1032,1034, 1036,1038, 1040 | G2010070 | GB | 1S1007 |
| | S6000020 | SWITCH LEVER, GRAY (for S1) | | | | | |
| | | RECEPTACLE | | | | | |
| J1 | P1090134 | SG7627 | | | | | |
| J2 | P1090004 | SG7814 | | | | | |
| J3 | P0090158 | FM214-8SS | | | | | |
| J4 | P1090005 | SG8050 | | D1026,1028, 1030 | G2090029 | Ge | 1N60 |
| J5 | P1090028 | MBR06B | | | | | |
| J6 | P1090152 | D8-703B-11 | | D1073-1075 | G2015550 | Si | 1S1555 |
| J7 | P1090034 | D7-701B-00 | | | | | |
| J8 | P0090026 | QS-1B4M | | | | | |
| | | RESISTOR | | | | | |
| J9,10,11 | P1090133 | STR-01H | | R1011,1064 | J00245479 | Carbon film | 1/4W VJ 4.7 Ω |

REPAIR PARTS

| | | | | | | | | | |
|---|-----------|--------------------|---------|-------|---|-----------|--|---------|-----------|
| R1101,1126 | J00245479 | Carbon film | 1/4W VJ | 4.7Ω | R1024,1034 | J00245563 | Carbon film | 1/4W VJ | 56kΩ |
| R1055,1057, 1058,1067, 1091 | J00245100 | " " | " " | 10Ω | R1025 | J00245394 | " " | " " | 390kΩ |
| R1118,1119 | J00245150 | " " | " " | 15Ω | R1030 | J00245564 | " " | " " | 560kΩ |
| R1050,1053 | J00245180 | " " | " " | 18Ω | R1023 | J00245225 | " " | " " | 2.2MΩ |
| R1032 | J00245470 | " " | " " | 47Ω | C1032,1036, 1171,1172, 1175,1176 | K02172040 | CAPACITOR Ceramic 50WV NPO 4pF | | |
| R1066 | J00245560 | " " | " " | 56Ω | C1068, 1153,1154 | K02172050 | " " | " " | 5pF |
| R1071,1120 | J00245680 | " " | " " | 68Ω | C1055,1173, 1174 | K02173060 | " " | " " | 6pF |
| R1007 | J00245820 | " " | " " | 82Ω | C1166 | K02173070 | " " | " " | 7pF |
| R1028,1031, 1070,1072, 1073,1076 1104,1124, 1125 | J00245101 | " " | " " | 100Ω | C1060,1061 | K02173080 | " " | " " | 8pF |
| R1056 | J00245121 | " " | " " | 120Ω | C1064 | K02173090 | " " | " " | 9pF |
| R1065,1102 | J10276151 | Carbon composition | 1/2W " | 150Ω | C1056,1069, 1155 | K02173100 | " " | " " | 10pF |
| R1012,1063, 1092,1100, 1103 | J00245221 | Carbon film | 1/4W VJ | 220Ω | C1148 | K02175120 | " " | " " | 12pF |
| R1013,1014, 1016, 1018 1020, 1021,1022, | J01245221 | " " | " TJ | 220Ω | C1052,1169, 1170 | K02175150 | " " | " " | 15pF |
| R1002,1008, 1049,1051, 1052,1054 | J00245271 | " " | " " | 270Ω | C1043,1165 | K02179009 | " " | " " | 22pF |
| R1090,1095 | J00245331 | " " | " " | 330Ω | C1049 | K02175330 | " " | " " | 33pF |
| R1122 | J00245471 | " " | " VJ | 470Ω | C1043 | K02175390 | " " | " " | 39pF |
| R1009,1062, | J00245561 | " " | " VJ | 560Ω | C1107 | K02179016 | " " | " " | 51pF |
| R1048 | J00245681 | " " | " " | 680Ω | C1046,1074, 1075 | K02175560 | " " | " " | 56pF |
| R1010,1027, 1029,1033, 1035,1042, 1044,1047, 1059,1060, 1079,1086, 1087,1098, 1110, 1112 1117 | J00245102 | " " | " " | 1kΩ | C1164,1167, 1168 | K02175680 | " " | " " | 68pF |
| R1036, 1038 1041, 1043,1045, 1046, 1080 1087, | J01245102 | " " | " TJ | 1kΩ | C1003,1010, 1012,1026 | K02175820 | " " | " " | 82pF |
| R1003,1004, 1061,1077, 1097,1099, 1128 | J00245152 | " " | " VJ | 1.5kΩ | C1030,1040 | K00175101 | " " | " " | SL 100pF |
| R1121,1123 | J00245182 | " " | " VJ | 1.8kΩ | C1025 | K02175121 | " " | " " | NPO 120pF |
| R1001,1075 | J00245472 | " " | " " | 4.7kΩ | C1027 | K02179027 | " " | " " | 270pF |
| R1005,1006, 1037,1074, 1078,1089, 1094,1105, 1107,1108 | J00245103 | " " | " " | 10kΩ | C1028 | K02175151 | " " | " " | 150pF |
| R1109 | J01245103 | " " | " TJ | 10kΩ | C1111 | K30176151 | Dipped mica | " " | 150pF |
| R1017,1106 | J00245153 | " " | " VJ | 15kΩ | C1109 | K30176331 | " " | " " | 330pF |
| R1015,1093 | J00245223 | " " | " " | 22kΩ | C1119 | K30176391 | " " | " " | 390pF |
| R1088 | J00245333 | " " | " " | 33kΩ | C1105 | K30176431 | " " | " " | 430pF |
| | J00245473 | " " | " " | 47kΩ | C1091,1092, 1184 | K30176471 | " " | " " | 470pF |
| | | | | | C1101 | K30176681 | " " | " " | 680pF |
| | | | | | | K30276102 | " " | " " | 1000pF |
| | | | | | C1097,1099, 1103 | K50177102 | Mylar | " " | 1000pF |
| | | | | | C1001 | K50177103 | " " | " " | 0.01μF |
| | | | | | C1002,1035, 1089 | K50177473 | " " | " " | 0.047μF |
| | | | | | C1005 1009, 1011, 1014- 1016, 1021 1024, 1027,1033, 1034,1037, 1038,1039, 1041,1042, 1044,1045, 1047,1048, 1050,1051, 1053,1054, 1057,1058, 1062,1063, 1065,1066, 1070-1073, 1076 1088, 1090 | K13170103 | Ceramic | " " | 0.01μF |

| | | | | | |
|--|-----------|--|--|-----------|-------------------------|
| C1093-1096, 1113-1118, 1121-1123, 1125-1130, 1132-1136, 1156, 1182 | K13170103 | Ceramic 50WV 0.01 μ F | T1040,1041 1042,1043 | L0020506 | |
| | | | T1044,1055 | L0020633 | |
| | | | | | |
| C1013,1017, 1020,1029, 1031,1098, 1100,1102, 1104,1106, 1108,1110, 1112, 1137-1147, 1150,1159, 1177,1178, 1179 | K13170473 | " " 0.047 μ F | J1001,1002 | P0090134 | RECEPTACLE PI051-06M |
| | | | J1003,1004 | P0090137 | PI051-09M |
| | | | J1005 | P0090140 | PI051-12M |
| | | | | Q5000011 | Wrapping terminal C |
| | | | | | |
| | | | | | |
| | | | | | |
| | | | | | |
| | | | | | |
| | | | | | |
| C1149, | K14179003 | " " 0.1 μ F | Symbol No. | Part No. | Description |
| C1018,1162, 1163,1180 | K40129004 | Electrolytic 16WV (16 RE 10) 10 μ F | PB-2094B | C0020940 | PCB with Components |
| | | | | F0002094B | Printed Circuit Board |
| C1161 | K40129016 | " " " 22 μ F | | | |
| C1157,1158, 1181 | K40129008 | " " " 33 μ F | | | FET, IC & TRANSISTOR |
| | | | Q2001,2004, 2005,2008 | G4800730G | FET 3SK73GR |
| C1160 | K40170105 | " " 50WV 1 μ F | Q2002,2003, 2020 | G3090035 | " 2SK19TM-GR |
| | | | | | |
| C1183 | K40170475 | Electrolytic 50WV 4.7 μ F | Q2007 | G3090019 | " J310 |
| C1151,1152 | K70127226 | Tantalum 16WV 22 μ F | Q2021,2025 | G3107331P | TR 2SA733A-P |
| C1019 | K19149021 | UAT08X473K-L45AE 0.047 μ F | Q2015 | G3305350A | " 2SC535A |
| | | | Q2010,2011 | G3315830G | " 2SC1583G |
| | | INDUCTOR | Q2023,2024 | G3318150G | " 2SC1815GR |
| L1001 | L0020491 | LPF Coil | Q2009,2012, 2013, 2016-2019, 2022 | G3318150Y | " 2SC1815Y |
| L1016 | L0020625 | " | | | |
| L1015 | L1190005 | FL4H-1R0M 1 μ H | | | |
| L1010 | L1190007 | FL4H1R8M 1.8 μ H | | | |
| L1012 | L1190005 | FL4H2R2M 2.2 μ H | Q2006 | G3319590Y | " 2SC1959Y |
| L1017 | L1190011 | FL4H4R7M 4.7 μ H | Q2014 | G3090005 | " MPS-A13 |
| L1013,1014 | L1190023 | FL5H220K 22 μ H | Q2026 | G1090123 | IC 78L08 |
| L1002,1008, | L1190033 | FL5H820K 82 μ H | | | |
| L1018,1019 | L1190020 | FL5H151K 150 μ H | | | |
| L1004 1007 | L1190038 | FL5H271K 270 μ H | | | |
| | | | | | DIODE |
| | | | D2017-2020, 2023-2025 | G2090029 | Ge 1N60 |
| | | TRANSFORMER | D2028 | G2090093 | Ge 1N270 |
| T1001 | L0020178 | | D2001,2003, 2009-2014 | G2010070 | Ge (GB) 1S1007 |
| T1003,1006, 1011,1012, 1017,1018 | L0020783 | | D2004,2015, 2016,2027, 2029-2032 | G2015550 | Si 1S1555 |
| | | | D2022 | G2090001 | Si 10D1 |
| T1004,1013, 1014 | L0020781 | | D2005,2006, 2026 | G2090027 | Si 1SS53 |
| T1005,1015, 1016 | L0020782 | | D2002 | G2090040 | Varactor FC63 |
| T1007,1009, 1019,1020, 1023,1024 | L0020784 | | D2021 | G2022090 | " 1S2209 |
| | | | | | |
| T1008,1010, 1021,1022, 1025,1026 | L0020785 | | | | CRYSTAL |
| T1027,1028 | L0020788A | | X2001 | H0100433 | HC-18/U 19.7475MHz |
| T1029 | L0020789A | | | | CRYSTAL FILTER |
| T1032,1033 | L0020501 | | XF2001 | H1100470 | 8.9875MHz 8.9M20 |
| T1034,1035 | L0020502 | | XF2002 | H1102010 | 10.76MHz XF10GW |
| T1030,1031, 1036,1037 | L0020504 | | XF2003 | H1100860 | 8.9875MHz XF8.9HS |
| | | | XF2004 | H1100880 | " XF8.9HC |
| T1038,1039 | L0020505 | | (OPTION) | | |

REPAIR PARTS

| | | | | | | | | |
|---|-----------|-----------------|----------|---------------------|---|----------------------|-------------------|-------------------|
| XF2004 (OPTION) | H1102019 | 8.9875MHz | XF8.9HCN | R2013,2014, 2054 | J01245104 | Carbon film | 1/4W TJ | 100k Ω |
| | | RESISTOR | | R2088,2090 | J00245184 | " " | " VJ | 180k Ω |
| R2077,2105 | J00245220 | Carbon film | 1/4W VJ | 22 Ω | J00245474 | " " | " " | 470k Ω |
| R2012,2017, 2022,2027, 2033,2036, 2052,2060, 2065,2070, 2082,2084 | J00245101 | " " | " " | 100 Ω | J00245155 | " " | " " | 1.5M Ω |
| | | | | | J00245565 | " " | " " | 5.6M Ω |
| | | | | | | POTENTIOMETER | | |
| R2056 | J01245101 | " " | " TJ | 100 Ω | VR2001,2002, 2005 | J51723472 | SR19R | 4.7k Ω |
| R2049 | J00245151 | " " | " VJ | 150 Ω | VR2003,2006 | J51723103 | " | 10k Ω |
| R2042,2044 | J00245181 | " " | " " | 180 Ω | VR2004 | J51723473 | " | 47k Ω |
| R2055 | J01245221 | " " | " TJ | 220 Ω | | | | |
| R2011,2045, 2083 | J00245331 | " " | " VJ | 330 Ω | | | THERMISTOR | |
| R2058,2062, 2047,2087, 2124 | J00245471 | " " | " " | 470 Ω | TH2001,2003 | G9090003 | D33A | |
| | | | | | TH2002 | G9090009 | 32D27 | |
| | | | | | | | | |
| R2010,2026, 2116,2125 | J00245561 | " " | " " | 560 Ω | | | CAPACITOR | |
| R2015,2016, 2043,2046 | J00245681 | " " | " " | 680 Ω | C2058 | K00172030 | Ceramic | 50WV SL 3pF |
| R2040,2041 | J01245681 | " " | " TJ | 680 Ω | C2077 | K00173100 | " " | " " 10pF |
| R2009, 2030-2032, 2047,2053, 2059,2063, 2068,2089, 2093,2099, 2101,2107, 2118 | J00245102 | " " | " VJ | 1k Ω | C2112 | K00175150 | " " | " " 15pF |
| R2100 | J00245152 | " " | " " | 1.5k Ω | C2065,2080, 2122 | K00175330 | " " | " " 33pF |
| R2003,2004, 2057,2076, 2120,2122, 2123 | J00245222 | " " | " " | 2.2k Ω | C2072,2075 | K06175330 | " " | " UJ 33pF |
| | J01245222 | " " | " TJ | 2.2k Ω | C2071 | K06175390 | " " | " " 39pF |
| R2007 | J00245272 | " " | " VJ | 2.7k Ω | C2049 | K00175470 | " " | " SL 47pF |
| R2061,2104 | J00245332 | " " | " " | 3.3k Ω | C2015,2020, 2047,2081, 2097 | K00175101 | " " | " " 100pF |
| R2067 | J00245472 | " " | " " | 4.7k Ω | C2069 | K06175101 | " " | " UJ 100pF |
| R2109 | J00245512 | " " | " " | 5.1k Ω | C2001,2066, 2082,2098 | K00175221 | " " | " SL 220pF |
| R2018,2028, 2064,2069, 2071,2106 | J00245562 | " " | " " | 5.6k Ω | C2062 | K00175331 | " " | " " 330pF |
| R2094,2108 | J00245682 | " " | " " | 6.8k Ω | C2043 | K10176102 | " " | " " 0.001 μ F |
| R2001,2002, 2020,2025, 2037 2039, 2072,2075, 2078,2086, 2092,2097, 2098,2102, 2113,2115, 2121 | J00245103 | " " | " " | 10k Ω | C2017,2018, 2023 | K19149013 | " | 25WV 0.01 μ F |
| R2023,2114 | J00245123 | " " | " VJ | 12k Ω | C2004,2006, 2008,2009, 2012,2013, 2014,2016, 2019,2021, 2022,2024, 2026,2027, 2029-2034, 2036-2038, 2040-2042, 2044,2045, 2046,2048, 2052-2057, 2059-2061, 2064,2068, 2070,2073, 2074,2076, 2078,2092, 2096, 2099-2101, 2103, 2104,2105, 2108-2111, 2113,2116, 2170,2122, 2123 | K13170103 | " | 50WV 0.01 μ F |
| R2051,2066, 2080,2081, | J00245153 | " " | " " | 15k Ω | | | | |
| R2074,2085 | J00245223 | " " | " " | 22k Ω | | | | |
| R2103 | J01245223 | " " | " TJ | 22k Ω | | | | |
| R2029 | J00245333 | " " | " VJ | 33k Ω | | | | |
| R2008,2024, 2079 | J00245473 | " " | " " | 47k Ω | | | | |
| R2019 | J01245473 | " " | " TJ | 47k Ω | | | | |
| R2073 | J00245563 | " " | " VJ | 56k Ω | C2079 | K13170222 | " " | " 0.022 μ F |

| | | | | | | |
|---|-----------|---|--|-----------|---------------------|-----------------------|
| C2003,2010,2011,2035,2039,2106,2117-2119 | K13170473 | Ceramic 50WV 0.047 μ F | Q3002,3013,3017,3040 | G31073310 | TR | 2SA733A-Q |
| | | | Q3025-3036,3038 | G3303800Y | " | 2SC380TM-Y |
| C2028,2050,2051,2083,2086,2088,2093,2094,2095,2107,2123 | K19149021 | " 25WV 0.047 μ F (UAT08X473K-L45AE) | Q3006 | G3090032 | " | 2SC732TM-GR |
| | | | Q3003,3005,3007,3010,3011,3012,3014-3016,3018,3020,3021,3023,3024,3039 | G3318150Y | " | 2SC1815Y |
| C2063 | K40170105 | Electrolytic 50WV 1 μ F | | | | |
| C2025 | K40170335 | " 50WV 3.3 μ F | | | | |
| C2005,2084,2091 | K40120106 | " 16WV 10 μ F | Q3009 | G3319590Y | " | 2SC1959Y |
| C2121 | K40100336 | " 10WV 33 μ F | | | | |
| C2089 | K70127224 | Tantalum 16WV 0.22 μ F | | | | |
| | | | | | | DIODE |
| | | | D3014,3015,3048 | G2090029 | Ge | 1N60 |
| | | | D3001,3012,3042 | G2010070 | Ge (GB) | 1S1007 |
| | | INDUCTOR | | | | |
| L2009 | L0020145 | VXO 5.2 μ H | D3017 | G2090001 | Si | 10D1 |
| L2003,2008 | L1190023 | FL5H-220K 22 μ H | D3002-3006,3011,3013,3016,3018-3041,3043-3046 | G2015550 | Si | 1S1555 |
| L2014 | L1190029 | FL5H-470K 47 μ H | | | | |
| L2013 | L1190030 | FL5H-560K 56 μ H | | | | |
| L2001,2002,2005,2007,2010,2015 | L1190016 | FL5H-101K 100 μ H | D3007-3010 | G2090118 | Schottky barrier | 1SS97 |
| L2011,2016 | L1190020 | FL5H-151K 150 μ H | | | | |
| L2012 | L1190017 | FL5H-102K 1mH | | | | CRYSTAL |
| | | | X3001 | H0100421 | HC-18/U | 8.986MHz |
| | | TRANSFORMER | X3002 | H0100423 | " | 8.989MHz |
| T2001,2003,2004,2010,2012 | L0020141 | 4171 | X3003 | H0100422 | " | 8.9883MHz |
| | | | X3004 | H0101560 | " | 24.4875MHz |
| T2002,2008,2009,2011,2013,2014 | L0020140 | 4170 | X3005 | H0102266 | " | 17.9845MHz |
| | | | X3006 | H0102267 | " | 21.4845MHz |
| T2005 | L0020150 | 4074 | X3007 | H0101500 | " | 28.4875MHz |
| T2006 | L0020460 | | X3008 | H0101510 | " | 35.4875MHz |
| T2007 | L0020209 | | X3009 | H0101520 | " | 42.4875MHz |
| | | | X3010 | H0101530 | " | 42.9875MHz |
| | | | X3011 | H0101540 | " | 43.4875MHz |
| | | | X3012 | H0101550 | " | 43.9875MHz |
| | | RELAY | X3013 | H0102295 | " | 32.4875MHz |
| RL2001 | M1190002 | FBR211AD012-M | X3014 | H0102296 | " | 38.9875MHz |
| | | | X3015 | H0102293 | HC 14W | 3200kHz |
| | | RECEPTACLE | | | | CRYSTAL SOCKET |
| J2003 | P0090134 | PI051-06M | XS3001 | P3090029 | | 4P |
| J2001 | P0090139 | PI051-11M | XS3002 | P3090042 | | 3P |
| J2002 | P0090140 | PI051-12M | | | | RESISTOR |
| | | | R3082 | J31276010 | Wire wound 1/2W | 1 Ω |
| | | | R3080 | J00245229 | Carbon film 1/4W VJ | 2.2 Ω |
| | | | R3076 | J00245180 | " " " " | 18 Ω |
| | | | R3033 | J00245820 | " " " VJ | 82 Ω |
| | | | R3001,3020,3097,3101,3105,3109,3113,3117,3121,3125,3129,3133,3137,3141,3160,3163-3170,3179 | J00245101 | " " " " | 100 Ω |
| PCB UNIT | | | | | | |
| Symbol No. | Part No. | Description | | | | |
| PB-2095B | C0020950 | PCB with Components | | | | |
| | F0002095B | Printed Circuit Board | | | | |
| | | | | | | |
| | | IC, FET & TRANSISTOR | | | | |
| Q3001 | G1090123 | IC 78L08 | | | | |
| Q3022 | G1090284 | " μ PC2002V | | | | |
| Q3037 | G1090064 | " F4024 | | | | |
| Q3004 | G3090035 | FET 2SK19TM-GR | R3008,3010,3144 | J00245151 | " " " " | 150 Ω |
| Q3008 | G3800301Y | " 2SK30A-Y | | | | |
| Q3019 | G3104960Y | TR 2SA496Y | R3011,3012 | J00245221 | " " " " | 220 Ω |

REPAIR PARTS

| | | | | | |
|---|-----------|--------------------------|---|-----------|---|
| R3081,3149, 3159,3176 | J00245221 | Carbon film 1/4W VJ 220Ω | R3038,3041, 3042,3058, 3092,3095, 3145,3150 | J00245223 | Carbon film 1/4W VJ 22kΩ |
| R3161,3162, 3178 | J00245331 | " " " " 330Ω | R3018,3024, 3045,3052 | J00245333 | " " " " 33kΩ |
| R3100,3104, 3108,3112, 3116,3120, 3124,3128, 3132,3136, 3140 | J00245391 | " " " " 390Ω | R3015,3026, 3030 | J00245473 | " " " " 47kΩ |
| R3143 | J01245471 | " " " TJ 470Ω | R3073 | J00245563 | " " " " 56kΩ |
| R3013,3032, 3040,3062, 3153 | J00245471 | " " " " 470Ω | R3006,3025 | J00245104 | " " " " 100kΩ |
| R3005,3023, 3048,3050, 3055,3071, 3077,3091, 3094,3148, 3151,3169 | J00245102 | " " " " 1kΩ | R3070 | J00245184 | " " " " 180kΩ |
| R3142 | J01245122 | " " " TJ 1.2kΩ | VR3001 | J51727101 | POTENTIOMETER CR19R 100Ω |
| R3049,3051, 3147 | J00245222 | " " " VJ 2.2kΩ | VR3002 | J51723103 | SR19R 10kΩ |
| R3173 | J00245272 | " " " " 2.7kΩ | VR3003 | J51723471 | 470Ω |
| R3004,3014, 3022,3037, 3047,3054, 3075, 3084-3090, 3098,3102, 3106,3110, 3114,3118, 3122,3126, 3130,3134, 3138,3154 | J00245332 | " " " " 3.3kΩ | C3137 | K00172060 | CAPACITOR Ceramic 50WV SL 6pF |
| R3021,3039 | J00245392 | " " " " 3.9kΩ | C3068,3070, 3072,3074, 3076,3078, 3080 | K02175150 | " "NPO 15pF |
| R3007,3009, 3035,3036, 3057,3061, 3063,3078, 3156 | J00245472 | " " " " 4.7kΩ | C3160 | K02175180 | " " " 18pF |
| R3002,3003, 3068,3069, 3072,3152 | J00245682 | " " " " 6.8kΩ | C3014 | K02179008 | " " " 20pF |
| R3017 | J00245822 | " " " " 8.2kΩ | C3138 | K00175220 | " " SL 22pF |
| R3027,3029, 3043,3044, 3056,3059, 3064,3066, 3067,3083, 3093,3146, 3155,3157, 3158,3171, 3174,3175, 3079 | J00245103 | " " " " 10kΩ | C3133 | K02179011 | " " NPO 27pF |
| R3019,3031, 3046,3053 | J00245123 | " " " VJ 12kΩ | C3004-3006, 3109,3113 3117,3121 | K02175390 | " " " 39pF |
| R3016,3034, 3060,3074, 3096,3099, 3103,3107, 3111,3115, 3119,3123, 3127,3131, 3135,3139 | J00245153 | " " " " 15kΩ | C3105 | K02175560 | " " " 56pF |
| | | | C3010,3011, 3093,3101 | K02175101 | " " " 100pF |
| | | | C3129 | K02175510 | " " " 51pF |
| | | | C3125 | K02175820 | " " " 82pF |
| | | | C3089 | K02175121 | " " NPO 120pF |
| | | | C3009,3097 | K02175151 | " " " 150pF |
| | | | C3016 | K00175221 | " " " 220pF |
| | | | C3135 | K00175271 | " " " 270pF |
| | | | C3140,3156, 3157,3159 | K12171102 | " " " 0.001μF |
| | | | C3001-3003, 3007,3008, 3012,3013, 3015,3035, 3067,3069, 3071,3073, 3075,3077, 3079,3081, 3085-3088, 3090-3092, 3094-3096, 3098-3100, 3102-3104, 3016-3108, 3110-3112, 3114, 3116, 3118-3120, 3122,3123, 3124,3115, 3126-3128, 3130,3131, 3136,3149, 3150, 3152-3155, 3158,3161, 3162 | K13170103 | " " " 0.01μF |

REPAIR PARTS

| | | | | | | | | | |
|--------------------------------------|-----------|--------------------------|-------|----------|-------------|-----------|------------------|----------|-----------------------------|
| C4004 | K30279082 | Dipped Mica | 500WV | 240pF | C4305 | K02179013 | Ceramic | 50WV NPO | 33pF |
| C4008,4033 | K30279085 | " | " | 330pF | | | | | |
| C4013,4017 | K30279086 | " | " | 360pF | | | | | |
| C4002 | K30279089 | " | " | 510pF | VC4301 | K90000024 | | | VARIABLE CAPACITOR |
| C4007,4011 | K30279113 | " | " | 680pF | | | | | C521R112 |
| C4005 | K30279095 | " | " | 1200pF | | | | | |
| C4051-4061 | K21170002 | Feed thru | 50WV | 1000pF | TC4301 | K90000001 | | | TRIMMER CAPACITOR |
| | | | | | | | | | TSN-100D15, 15pF |
| | | | | | | | | | INDUCTOR |
| TC1001 | K91000019 | TRIMMER CAPACITOR | | | L4301 | L0020268 | | | |
| | | ECV1ZW-10x40, | | | | | | | |
| | | | | | | | | | PILOT LAMP |
| | | | | | PL4301,4302 | Q1000035 | | | BQ044-22836A |
| | | | | | | | | | FET & TRANSISTOR |
| L4001 | L0020615 | INDUCTOR | | | Q4302 | G3090035 | FET | | 2SK19TM-GR |
| L4002 | L0020616 | | | | Q4301,4303 | G3318150Y | TR | | 2SC1815Y |
| L4003 | L0020617 | | | | | | | | |
| L4004 | L0020618 | | | | | | | | DIODE |
| L4005 | L0020854 | | | | D4301 | G2022360 | Varactor | | 1S2236 |
| L4006 | L0020855 | | | | | | | | |
| L4007 | L0020621 | | | | | | | | |
| L4008 | L0020622 | | | | | | | | |
| L4009 | L0020623 | | | | | | | | RESISTOR |
| L4010 | L0020624 | | | | R4309,4311 | J00245101 | Carbon film | 1/4W VJ | 100Ω |
| | | | | | R4307 | J00245221 | " | " | 220Ω |
| | | | | | R4305,4308 | J00245222 | " | " | 2.2kΩ |
| | | TRANSFORMER | | | R4302 | J00245332 | " | " | 3.3kΩ |
| T4001 | L0020301A | | | | R4301 | J00245103 | " | " | 10kΩ |
| | | | | | R4303 | J00245183 | " | " | 18kΩ |
| | | RELAY | | | R4304 | J00245223 | " | " | 22kΩ |
| RL4001-4011 | M1190024 | FBR311D012 | | | R4306,4310 | J00245104 | " | " | 100kΩ |
| | | | | | | | | | |
| ***** CONNECTOR A BOARD ***** | | | | | | | | | |
| PB-2109 | F0002109 | Printed Circuit Board | | | | | | | CAPACITOR |
| | | | | | C4327 | K02179001 | Ceramic | 50WV NPO | 1pF |
| | | CONNECTOR | | | C4307 | K02173080 | " | " | 8pF |
| J4002 | P0090150 | PI021-06M | | | C4314 | K02179013 | " | " | 33pF |
| | | | | | C4308,4318 | K02175390 | " | " | 39pF |
| | | | | | C4311 | K02179023 | " | " | 180pF |
| PB-2110 | F0002110 | Printed Circuit Board | | | C4321,4323 | K00175471 | " | " | SL 470pF |
| | | CONNECTOR | | | C4309,4310, | K13170103 | " | " | 0.01μF |
| J4001 | P0090149 | PI021-05M | | | 4312,4315, | | | | |
| | | | | | 4319,4320, | | | | |
| | | | | | 4324,4326 | | | | |
| | | CAPACITOR | | | C4313 | K30176431 | Dipped Mica | " | 430pF |
| C4074-4079 | K13170473 | Ceramic | 50WV | 0.047μF | C4302,4322 | K30209001 | " | " | 1000pF |
| | | | | | C4325 | K70167334 | Tantalum | 10WV | 0.33μF |
| | Q5000011 | Wrapping terminal C | | | | | | | |
| | | | | | | | | | |
| | | | | | | | | | TRIMMER CAPACITOR |
| | | | | | TC4302 | K91000023 | | | ECV-1ZW 50x40, 50pF |
| | | | | | | | | | |
| VFO UNIT | | | | | | | | | INDUCTOR |
| Symbol No. | Part No. | Description | | | L4304,4305 | L1190007 | FL4H-1R8M, 1.8μH | | |
| | | VFO assembly (3540) | | | L4303,4306 | L1190001 | 250μH | | |
| | | VFO chassis | | | L4302 | L1190040 | S4 1mH | | |
| PB-2097A | F0002097A | VFO board | | | | | | | |
| | | | | | | | | | RECEPTACLE |
| ***** VFO CHASSIS ***** | | | | | J4301 | P0090133 | PI021-05M | | |
| | | | | | | | | | CAPACITOR |
| C4301 | K06173080 | Ceramic | 50WV | UJ 8pF | | | | | |
| C4303 | K06175120 | " | " | 12pF | | | | | |
| C4304 | K02175180 | " | " | NPO 18pF | | | | | |

| COUNTER UNIT 13540 | | | C4417,4419, 4421, 4426-4429 | K13170103 | Ceramic | 50WV NPO 0.01 μ F |
|---|-----------|---------------------------------|-----------------------------------|-----------|----------------------------------|-----------------------------------|
| Symbol No. | Part No. | Description | | | | |
| | C0020861A | COUNTER UNIT ASSEMBLY | | | | |
| | C9020861A | COUNTER MAIN UNIT | C4423 | K50177103 | Mylar | 0.01 μ F |
| | F0002086A | COUNTER MAIN BOARD | C4410,4418 | K40120106 | Electrolytic | 16WV 10 μ F |
| | | | C4416 | K40129001 | " | 16WV 330 μ F |
| | | | C4413 | K40109004 | " | 10WV 470 μ F |
| ***** COUNTER MAIN BOARD ***** | | | C4422 | K71137685 | Tantalum | 20WV 6.8 μ F (CC99E1D6R8M) |
| IC, FET & TRANSISTOR | | | | | | |
| Q4412 | G1090249 | IC MSM9520RS | | | | |
| Q4420 | G1090079 | " μ PA54H | | | | |
| Q4401 | G4800730 | FET 3SK73GR | | | | TRIMMER CAPACITOR |
| Q4406-4411, 4413-4419 | G3109520L | TR 2SA952L | TC4401 | K91000030 | ECV1ZW 40x53, 40pF | |
| Q4403 | G3316740 | " 2SC1674L | | | | INDUCTOR |
| Q4404 | G3318150G | " 2SC1815GR | L4401 | L2030068 | SN Coil | 2mH |
| | | | | | | RECEPTACLE |
| | | DIODE | J4401 | P0090051 | 5048-06A | |
| D4401-4413 | G20155550 | Si 1S1555 | J4402 | P0090054 | 5048-07A | |
| | | | J4403 | P0090037 | 5048-08A | |
| | | CRYSTAL | | | | |
| X4401 | H0102272 | HC-18/U 6.5536MHz | | | | PLUG |
| | | | P4403 | P1090186 | 3021-03A | |
| | | RESISTOR | | | | |
| R4412 | J00245100 | Carbon film 1/4W VJ 10 Ω | ***** DISPLAY BOARD ***** | | | |
| R4431,4434, 4437,4440, 4443,4446, 4449 | J00245330 | " " " " 33 Ω | | C002098A | PCB with components | |
| | | | | F0002098A | Printed Circuit Board | |
| | | | | | | DISPLAY LED |
| R4450 | J00245560 | " " " " 56 Ω | D4501-4506 | G2090069 | HP5082-7623 | |
| R4401 | J01245560 | " " " TJ 56 Ω | | | | PLUG |
| R4408,4418, 4420,4422, 4424,4426, 4428 | J00245101 | " " " VJ 100 Ω | P4501 | | 5047-06 | |
| | | | P4502 | | 5047-08 | |
| R4407,4410, 4411 | J00245221 | " " " " 220 Ω | | | | |
| R4417,4419, 4421,4423, 4425,4427, 4430,4433, 4436,4439, 4442,4445, 4448 | J01245102 | " " " TJ 1k Ω | *AVR UNIT* | | | |
| | | | Symbol No. | Part No. | Description | |
| | | | PB-2099A | C0020990 | PCB with Components | |
| | | | | F0002099A | Printed Circuit Board | |
| | | | | | | IC TRANSISTOR & FET |
| R4429,4432, 4435,4438, 4441,4444, 4447 | J00245152 | " " " VJ 1.5k Ω | Q4602 | G1090070 | IC μ PC14308 | |
| | | | Q4601 | G3408800 | TR 2SD880Y | |
| | | | Q4603 | G3090035 | FET 2SK19TM-GR | |
| | | | | | | DIODE |
| R4402,4415 | J00245562 | " " " " 5.6k Ω | D4601 | G2090001 | Si 10D1 | |
| R4413 | J00245103 | " " " " 10k Ω | D4602 | G2090015 | Zener RD-6.2EB | |
| R4409 | J00245473 | " " " " 47k Ω | | | | RESISTOR |
| R4404 | J01245473 | " " " TJ 47k Ω | | | | |
| R4414,4416 | J01245104 | " " " " 100k Ω | R4602 | J30356100 | Wire wound 3W 10 Ω | |
| | | | R4607 | J00245479 | Carbon film 1/4W VJ 4.7 Ω | |
| | | CAPACITOR | R4601 | J00245330 | Carbon film 1/4W 33 Ω | |
| C4424 | K02179008 | Ceramic 50WV NPO 20pF | R4603 | J00245332 | " " " 3.3k Ω | |
| C4425 | K02175820 | " " " " 82pF | R4604,4606 | J00245682 | " " " 6.8k Ω | |
| C4420 | K02175101 | " " " " 100pF | R4605 | J00245123 | " " " 12k Ω | |
| C4401,4404 | K13170102 | " " " " 0.001 μ F | | J00245153 | " " " 15k Ω | |
| C4402,4405, 4408,4409, 4411,4412, 4414,4415. | K13170103 | " " " " 0.01 μ F | | | | POTENTIOMETER |
| | | | VR4601 | J50710502 | V10K8-1-2 5k Ω B | |

REPAIR PARTS

| | | CAPACITOR | | | | | RESISTOR | | |
|-------------------------------------|-----------|-----------------------|----------|---------------|-----------------------|-----------|-----------------------|-------------|---------------|
| C4606-4610, 4614 | K13170473 | Ceramic | 50WV | 0.047 μ F | R4801,4811 | J00245102 | Carbon film | 1/4W VJ | 1k Ω |
| C4604 | K50177104 | Mylar | " | 0.1 μ F | R4807,4810, 4814 | J00245562 | " | " | 5.6k Ω |
| C4605 | K40109007 | Electrolytic | 10WV | 220 μ F | R4815 | J00245682 | " | " | 6.8k Ω |
| C4603 | K40129009 | " | 16WV | 220 μ F | R4802,4809, 4812,4813 | J00245103 | " | " | 10k Ω |
| C4602 | K40129001 | " | " | 330 μ F | R4804 | J00245433 | " | " | 43k Ω |
| C4601 | K40129011 | " | " | 1000 μ F | R4803,4806 | J00245473 | " | " | 47k Ω |
| C4611 | K40170105 | Electrolytic | 50WV | 1 μ F | R4805 | J00245563 | " | " | 56k Ω |
| C4613 | K40120106 | " | 16WV | 10 μ F | R4808 | J00245683 | " | " | 68k Ω |
| C4612 | K70127224 | Tantalum | 16WV | 0.22 μ F | | | | | |
| | | RELAY | | | | | CAPACITOR | | |
| RL4601 | M1190023 | FBR321D012 | | | C4801,4802, 4805,4806 | K13170103 | Ceramic | 50WV | 0.01 μ F |
| RL4602 | M1190006 | FBR221D012 | | | C4803,4804 | K70127106 | Tantalum | 16WV | 10 μ F |
| | | | | | C4808 | K30209001 | Dipped mica | 50WV | 1000pF |
| | Q5000011 | Wrapping terminal C | | | C4807,4809 | K30209003 | " | " | 1500pF |
| | | | | | | | INDUCTOR | | |
| INDICATOR UNIT | | | | | L4803,4804 | L1190080 | LB4B3R3J, | 3.3 μ H | |
| Symbol No. | Part No. | Description | | | L4801,4806 | L1190093 | LB4B8R2J, | 8.2 μ H | |
| PB-2100A | C0021000 | PCB with Components | | | L4802,4805 | L1190094 | LB4B100J, | 10 μ H | |
| | F0002100 | Printed Circuit Board | | | | | | | |
| | | | | | | | LAMP FUSE | | |
| | | IC | | | F4801 | Q1000010 | BQ041-22803A | | |
| Q4701 | G1090241 | TA7612AP | | | | | | | |
| | | | | | | | RECEPTACLE | | |
| | | DIODE | | | J4801,4803 | P0090120 | P1051-02M | | |
| D4701-4705 | G2090136 | LED | TLG205 | | J4802 | P0090121 | P1051-03M | | |
| D4706-4708 | G2090134 | " | TLY205 | | | | | | |
| D4709,4710 | G2090137 | " | TLR205 | | | Q5000011 | Wrapping terminal C | | |
| D4711 | G2090001 | Ge | 1N60 | | | | | | |
| | | | | | | | SW UNIT | | |
| | | RESISTOR | | | Symbol No. | Part No. | Description | | |
| R4702-4706 | J01245331 | Carbon film | 1/4W TJ | 330 Ω | PB-2102A | C0021020 | PCB with Components | | |
| | J01245391 | " | " | 390 Ω | | F0002102 | Printed Circuit Board | | |
| R4707-4709 | J01245471 | " | " | 470 Ω | | | | | |
| R4713 | J01245102 | " | " | 1k Ω | | | | | |
| R4710,4711 | J01245152 | " | " | 1.5k Ω | R4901-4903 | J00245561 | Carbon film | 1/4W VJ | 560 Ω |
| R4712 | J01245103 | " | " | 10k Ω | R4904 | J01245103 | " | " | 10k Ω |
| R4701 | J01245393 | " | " | 39k Ω | | | | | |
| | | | | | | | CAPACITOR | | |
| C4702 | K13170473 | Ceramic | 50WV | 0.047 μ F | C4901,4902 | K13170473 | Ceramic | 50WV | 0.047 μ F |
| C4701 | K40129009 | Electrolytic | 16WV | 220 μ F | C4903 | K70147105 | Tantalum | 16WV | 1 μ F |
| C4703 | K13170102 | Ceramic | 50WV | 0.001 μ F | | | | | |
| | | | | | | | SWITCH | | |
| | | | | | S4901 | N4090030 | SUT71A | | |
| | | | | | | | VR A UNIT | | |
| HPF (FAN MOTOR CONTROL) UNIT | | | | | Symbol No. | Part No. | Description | | |
| Symbol No. | Part No. | Description | | | PB-2103A | C0021030 | PCB with Components | | |
| PB-2101A | C0021010 | PCB with Components | | | | F0002103 | Printed Circuit Board | | |
| | F0002101 | Printed Circuit Board | | | | | | | |
| | | | | | | | POTENTIOMETER | | |
| | | IC, TRANSISTOR | | | VR5001 (VOX GAIN) | J51734103 | CR19D | | 10k Ω |
| Q4801 | G1090246 | IC | AN6552 | | | | | | |
| Q4805 | G1090123 | " | 78L08 | | | | | | |
| Q4802,4804 | G3318150Y | TR | 2SC1815Y | | | | VR B UNIT | | |
| Q4803 | G3405920Q | " | 2SD592Q | | Symbol No. | Part No. | Description | | |
| | | | | | PB-2103A | C0021031 | PCB with Components | | |
| | | | | | | F0002103 | Printed Circuit Board | | |
| | | | | | | | POTENTIOMETER | | |
| D4802 | G2090001 | Si | 10D1 | | VR5101 (DELAY) | J51734224 | CR19D | | 220k Ω |
| D4801,4803, 4804 | G2015550 | Si | 1S1555 | | | | | | |

REPAIR PARTS

| RF UNIT | | | R1040-1046, 1054,1062, 1065,1068, 1100,1108 | J00245102 | Carbon film 1/4W VJ 1k Ω |
|---|-----------|---------------------------------------|---|-----------|---------------------------------|
| Symbol No. | Parts No. | Description | | | |
| PB-2201 | F0002201 | Printed Circuit Board | | | |
| | C0022010 | PCB with Components | | | |
| | | IC, FET & TRANSISTOR | R1047, 1101-1107 | J01245102 | " " " TJ 1k Ω |
| Q1006 | G1090062 | IC SN76514N | R1003,1004, 1084,1086 | J00245152 | " " " VJ 1.5k Ω |
| Q1008 | G2090135 | Diode Quad ND487C2-3R | R1014 | J00245332 | " " " " 3.3k Ω |
| Q1001,1002 | G4800730G | FET 3SK73GR | R1031,1032, 1093,1094 | J00245182 | " " " " 1.8k Ω |
| Q1013 | G3303800Y | TR 2SC380TM-Y | R1015,1130 | J00245562 | " " " " 5.6k Ω |
| Q1005,1007 | G3318150Y | " 2SC1815Y | R1001,1013, 1033,1096 | J00245472 | " " " " 4.7k Ω |
| Q1010,1011 | G3319230R | " 2SC1923R | R1076,1077, 1080,1083, 1085,1097, 1109,1115, 1128 | J00245103 | " " " " 10k Ω |
| Q1004 | G3319590Y | " 2SC1959Y | R1078,1079 | J01245103 | " " " TJ 10k Ω |
| Q1003,1009, 1012 | G3324070 | " 2SC2407 | R1027 | J00245153 | " " " VJ 15k Ω |
| | | DIODE | R1116 | J00245223 | " " " " 22k Ω |
| D1001-1010, 1039-1040, 1044-1048, 1057-1074 | G2090027 | Si 1S553 | R1110 | J00245333 | " " " " 33k Ω |
| D1020,1021, 1042 | G2015550 | Si 1S1555 | R1025,1063 | J00245563 | " " " " 56k Ω |
| D1049-1056 | G2090001 | Si 10D1 | R1026 | J00245394 | " " " " 390k Ω |
| D1011-1019, 1043 | G2090118 | Schottky Barrier 1SS97 | R1064 | J00245564 | " " " " 560k Ω |
| D1022-1030, 1041 | G2010070 | Ge(GB) 1S1007 | R1027 | J00245225 | " " " " 2.2M Ω |
| | | | | | CAPACITOR |
| | | | C1151 | K30176151 | Dipped mica 50WV 150pF |
| | | | C1150 | K30176331 | " " " 330pF |
| | | RESISTOR | C1178 | K30176391 | " " " 390pF |
| R1057,1072, 1075,1120 | J00245479 | Carbon film 1/4W VJ 4.7 Ω | C1148 | K30176431 | " " " 430pF |
| R1060,1112 | J00245100 | " " " " 10 Ω | C1124,1125 | K30176471 | " " " 470pF |
| R1050,1051, 1125 | J00245180 | " " " " 18 Ω | C1146 | K30176681 | " " " 680pF |
| R1066 | J00245470 | " " " " 47 Ω | C1053,1099 | K02179003 | Ceramic " CH2pF |
| R1090 | J00245560 | " " " " 56 Ω | C1019,1208 | K02179004 | " " " CJ 3pF |
| R1089 | J00245680 | " " " " 68 Ω | C1066,1152, 1153 | K02172040 | " " " CH4pF |
| R1073 | J10276820 | " composition 1/2W GK 82 Ω | C1028,1063 | K02173080 | " " " 8pF |
| R1029,1067, 1087,1088, 1092,1098, 1099,1114, 1129 | J00245101 | " film 1/4W VJ 100 Ω | C1018,1064 | K02173090 | " " " 9pF |
| R1058,1121 | J10276151 | " composition 1/2W GK 150 Ω | C1030,1065, 1069,1071 | K02173100 | " " " 10pF |
| R1016-1023 | J01245221 | " film 1/4W TJ 220 Ω | C1026,1062, 1072 | K02175120 | " " " 12pF |
| R1059,1074, 1113,1122, 1126 | J00245221 | " " " VJ 220 Ω | C1021,1029 | K02175150 | " " " 15pF |
| R1002,1048, 1049,1052, 1053,1069, 1123,1124 | J00245271 | " " " " 270 Ω | C1025,1027, 1068,1070 | K02175180 | " " " 18pF |
| R1111,1117 | J00245331 | " " " " 330 Ω | | K02179008 | " " " 20pF |
| R1095 | J00245471 | " " " " 470 Ω | C1015-1017, 1020,1025 | K02179009 | " " " 22pF |
| R1055,1070, 1071,1119 | J00245561 | " " " " 560 Ω | C1022,1059 | K02179010 | " " " 24pF |
| R1091 | J00245681 | " " " " 680 Ω | C1024,1061, 1067 | K02179011 | " " " 27pF |
| R1034-1039, 1056,1118 | J00245821 | " " " " 820 Ω | C1013 | K02179013 | " " " 33pF |
| R1024,1028, 1030 | J00245102 | " " " " 1k Ω | C1003,1205 | K02175390 | " " " 39pF |
| | | | C1002,1206 | K02175470 | " " " 47pF |
| | | | C1149 | K02179016 | " " " 51pF |
| | | | C1014,1023, 1180,1181 | K02175560 | " " " 56pF |
| | | | C1060 | K02179017 | " " " 62pF |
| | | | C1001,1107, 1108 | K02175820 | " " " 82pF |
| | | | C1049,1093 | K00175101 | " " SL 100pF |
| | | | C1004,1204 | K02175121 | " " CH 120pF |
| | | | C1006-1008 | K13170103 | " " 0.01 μ F |

| | | | | | | | | |
|--|-----------|---|-----------|---------------|--|-----------|---------------------|-----|
| C1010,1012, 1031-1038, 1047,1048, 1051,1054, 1055,1058, 1073-1081, 1083-1085, 1087-1089, 1091,1094, 1095,1098, 1100,1101, 1106, 1121-1123, 1126-1131, 1135, 1137-1140, 1169-1171, 1174-1177, 1179,1182, 1183,1185, 1187-1194 | K13170103 | Ceramic | 50WV | 0.01 μ F | L1006,1007 | L1190017 | FL5H 102K | 1mH |
| | | | | | | | | |
| | | | | | | | TRANSFORMER | |
| | | | | | T1001 | L0020178 | | |
| | | | | | T1002,1003, 1018,1019 | L0020892 | | |
| | | | | | T1004,1005 | L0020894 | | |
| | | | | | T1006,1007, 1022,1023 | L0020782 | | |
| | | | | | T1008,1009, 1024,1025 | L0020891 | | |
| | | | | | T1010,1011, 1026,1027 | L0020784 | | |
| | | | | | T1012,1013 | L0020893 | | |
| | | | | | T1014,1015, 1030,1031 | L0020890 | | |
| | | | | | T1016,1017, 1028,1029, 1032,1033 | L0020785 | | |
| | | | | | T1020,1021 | L0020781 | | |
| C1005,1050, 1052,1057, 1086,1102, 1103,1104, 1109, 1111-1120, 1154-1168, 1186 | K13170473 | " | " | 0.047 μ F | T1034,1035 | L0020788A | | |
| | | | | | T1036 | L0020789A | | |
| | | | | | T1037,1038, 1043,1044 | L0020504 | | |
| | | | | | T1039,1040 | L0020501 | | |
| | | | | | T1041,1042 | L0020502 | | |
| | | | | | T1045,1046, 1049,1050 | L0020505 | | |
| C1142 | K13179007 | " | " | 0.1 μ F | T1047,1048 | L0020506 | | |
| C1144,1145, 1147 | K50177102 | Mylar | 50WV | 0.001 μ F | T1051,1052 | L0020633 | | |
| C1011 | K50177103 | " | " | 0.01 μ F | | | | |
| C1056,1141 | K50177473 | " | " | 0.047 μ F | | | RECEPTACLE | |
| C1082,1092, 1110 | K19149021 | Semiconductor ceramic (UAT08X473K-L45AE) | 25WV | 0.047 μ F | J1001,1002 | P0090134 | PI051-06M | |
| C1143,1173 | K70127226 | Tantalum | 16WV | 22 μ F | J1003,1004 | P0090137 | PI051-09M | |
| C1097 | K40179012 | Electrolytic (50RE475) | 50WV | 4.7 μ F | J1005 | P0090140 | PI051-12M | |
| C1105,1134, 1136 | K40129004 | " | (16RE106) | | | | | |
| | | | 16WV | 10 μ F | | Q5000011 | Wrapping terminal C | |
| C1009 | K40129016 | " | (16RE226) | | | | | |
| | | | 16WV | 22 μ F | | | | |
| C1039-1046, 1172,1184, 1195-1203 | K40129008 | " | (16RE336) | | | | | |
| | | | 16WV | 33 μ F | | | | |
| C1096 | K40109002 | " | (10RE476) | | | | | |
| | | | 10WV | 47 μ F | | | | |
| | | INDUCTOR | | | | | | |
| L1001,1025 | L0020898 | | | | | | | |
| L1002,1009 | L0020491 | | | | | | | |
| L1016 | L0020625 | T25-6 | | | | | | |
| L1013,1015 | L1190005 | FL4H 1R0M | | 1 μ H | | | | |
| L1010 | L1190007 | FL4H 1R8M | | 1.8 μ H | | | | |
| L1011 | L1190008 | FL4H 2R2M | | 2.2 μ H | | | | |
| L1022,1024 1026, | L1190011 | FL4H 4R7K | | 4.7 μ H | | | | |
| L1021 | L1190014 | FL4H 100K | | 10 μ H | | | | |
| L1012,1014, 1017,1020, 1023 | L1190023 | FL5H 220K | | 22 μ H | | | | |
| L1005,1008 | L1190033 | FL5H 820K | | 82 μ H | | | | |
| L1018,1019 | L1190016 | FL5H 101K | | 100 μ H | | | | |
| L1003,1004 | L1190017 | FL5H 102K | | 1mH | | | | |

POWER SUPPLY FP-707

| MAIN CHASSIS | | | | *T9013284 | 3 wire, 2 prong EU plug |
|----------------|-----------|--|--------------|-----------|--|
| Symbol No. | Part No. | Description | | | |
| | | TRANSISTOR | | | AC POWER SOCKET |
| Q1,2,3 | G34071700 | 2SD717-O | | | *(200V-234V only) |
| | | | | P0090094 | PA125 |
| | | DIODE | | | |
| D1 | G2090121 | Si (Bridge) S25VB10 | | | |
| | | RESISTOR | | | |
| R1 | J30379002 | Cement 5W 10 Ω (SQ5L 10 Ω) | | | |
| R2,3,4 | J30379001 | Cement 5W 0.05 Ω (SQ5L R05) | | | |
| | | | | | AVR UNIT |
| | | | Symbol No. | Part No. | Description |
| | | | PB2156 | F0002156 | Printed Circuit Board |
| | | | | C0021560 | PCB with components |
| | | CAPACITOR | | | |
| C1,2 | K12329001 | Ceramic 1.4KVDC 0.01 μ F (ECK-DAL103PE) | | | FET, TRANSISTOR |
| C6 | K13170473 | " 50WV 0.047 μ F (DB207YF473Z5L5) | Q101 | G3090036 | FET 2SK19TM-BL |
| C7 | K40120108 | Electrolytic 16WV 1000 μ F (16RL1000) | Q103 | G3109500Y | TR 2SA950-Y |
| C3,4,5 | K43140005 | " 25WV 33000 μ F (25LE33000) | Q102 | G3110120Y | " 2SA1012-Y |
| | | | | | DIODE |
| | | | D101,102,105 | G2090001 | Si 10D1 |
| | | | D104 | G2015550 | " 1S1555 |
| | | | D103 | G2090047 | Zener WZ061 |
| | | POWER TRANSFORMER | | | |
| PT1 | L3030081 | | | | |
| | | | | | RESISTOR |
| | | | R106 | J10276270 | Carbon composition 1/2W GK 27 Ω |
| | | SPEAKER | | | |
| SP1 | M4090048 | SE128D-1 4 Ω 3W | R101 | J10245560 | " film 1/4W VJ 56 Ω |
| | | | R102 | J10245821 | " " " " 820 Ω |
| | | RELAY | R105 | J10245222 | " " " " 2.2k Ω |
| RL1 | M1090016 | FRL263D012/01CS-OE | R103,104 | J10245332 | " " " " 3.3k Ω |
| | | | | | |
| | | SWITCH | | | POTENTIOMETER |
| S1 | N2090024 | 8H2011 | VR101 | J50735472 | CR29R4.7KB 4.7K Ω B |
| | S6000026 | Switch lever (gray) | | | |
| | | | | | CAPACITOR |
| | Q5000008 | OUTPUT TERMINAL | C104 | K50177223 | Mylar 50WV 0.022 μ F |
| | Q5000009 | T203 (red) | C103 | K50177473 | " " " 0.047 μ F |
| | | T203 (black) | C101 | K40149010 | Electrolytic 25WV 330 μ F (25RE330) |
| | | | | | |
| | | FUSE HOLDER | C102,105 | K40129011 | " 16WV 1000 μ F (16RE1000) |
| FH1 | P2000012 | SN2059 | | | |
| | | | | | |
| | | FUSE | | | |
| F1 (100V-117V) | Q0000012 | 6A | | | |
| F1 (200V-234V) | Q0000004 | 3A | | | |
| | | | | | |
| | | PILOT LAMP (LED) | | | |
| PL1 | G2090141 | DB20 (Red) | | | |
| | | | | | |
| | | TERMINAL BOARD | | | |
| | Q6000013 | 1L5P(S) (2-0-3) | | | |
| | Q6000014 | 1L5P(S) (3-0-2) | | | |
| | | | | | |
| | DC/SP | CONNECTION CORD | | | |
| | T9203030 | | | | |
| | P1090042 | POWER PLUG QMS-P4FK | | | |
| | P0090034 | SPEAKER PLUG P2240 | | | |
| | | | | | |
| | | AC POWER CORD | | | |
| | T9000180 | 2 wire, 2 prong plug | | | |
| | T9000482 | 3 wire, 3 prong plug (UL) | | | |
| | *T9013283 | 3 wire, 3 prong Australian plug | | | |

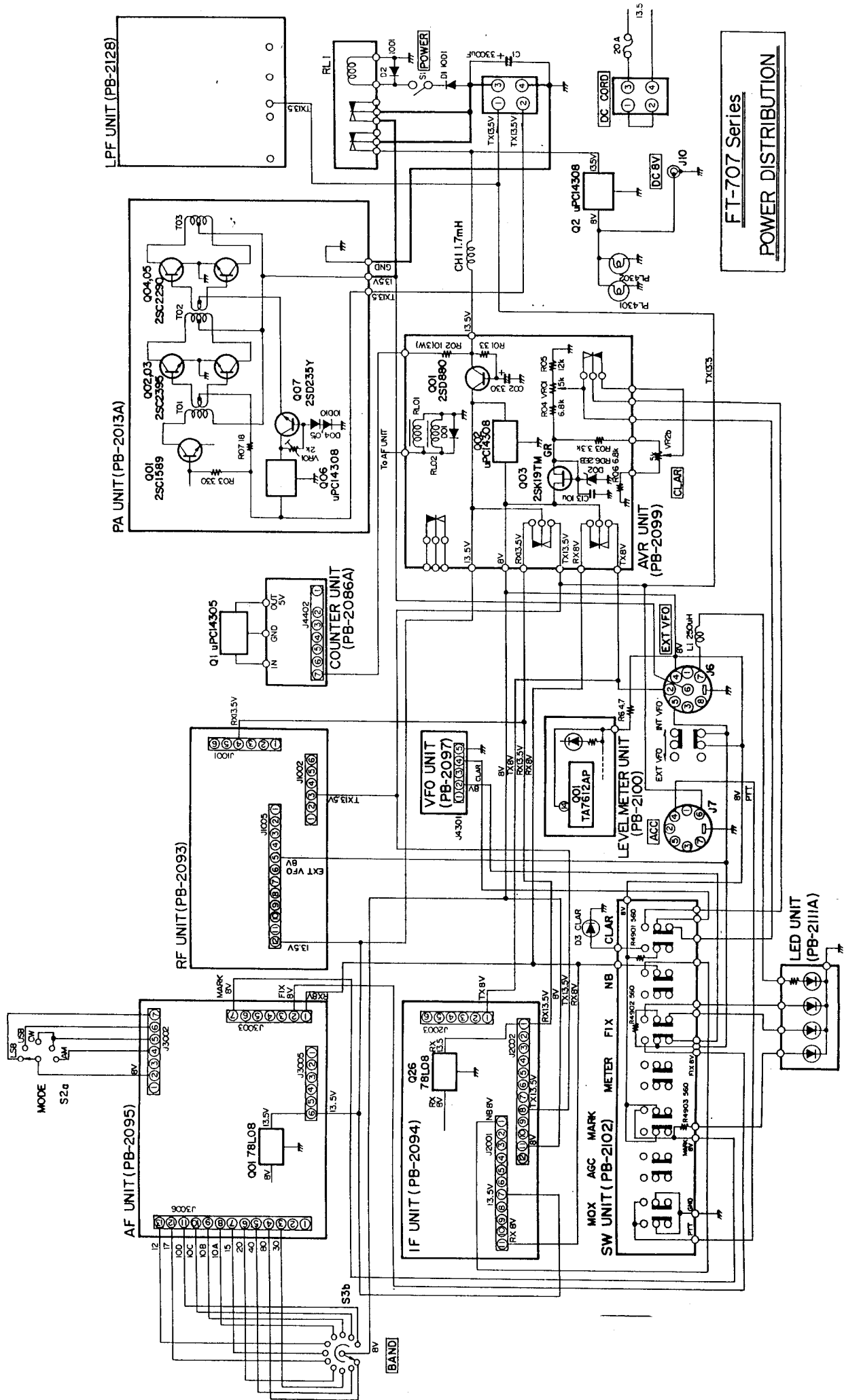

FT-707 Series
POWER DISTRIBUTION

LPF UNIT (PB-2128)

PA UNIT (PB-2013A)

COUNTER UNIT (PB-2086A)

RF UNIT (PB-2093)

IF UNIT (PB-2094)

AF UNIT (PB-2095)

MOX UNIT (PB-2102)

SW UNIT (PB-2102)

METER (FIX NB)

VFO UNIT (PB-2097)

LEVEL METER UNIT (PB-2100)

AVR UNIT (PB-2099)

LED UNIT (PB-2111A)

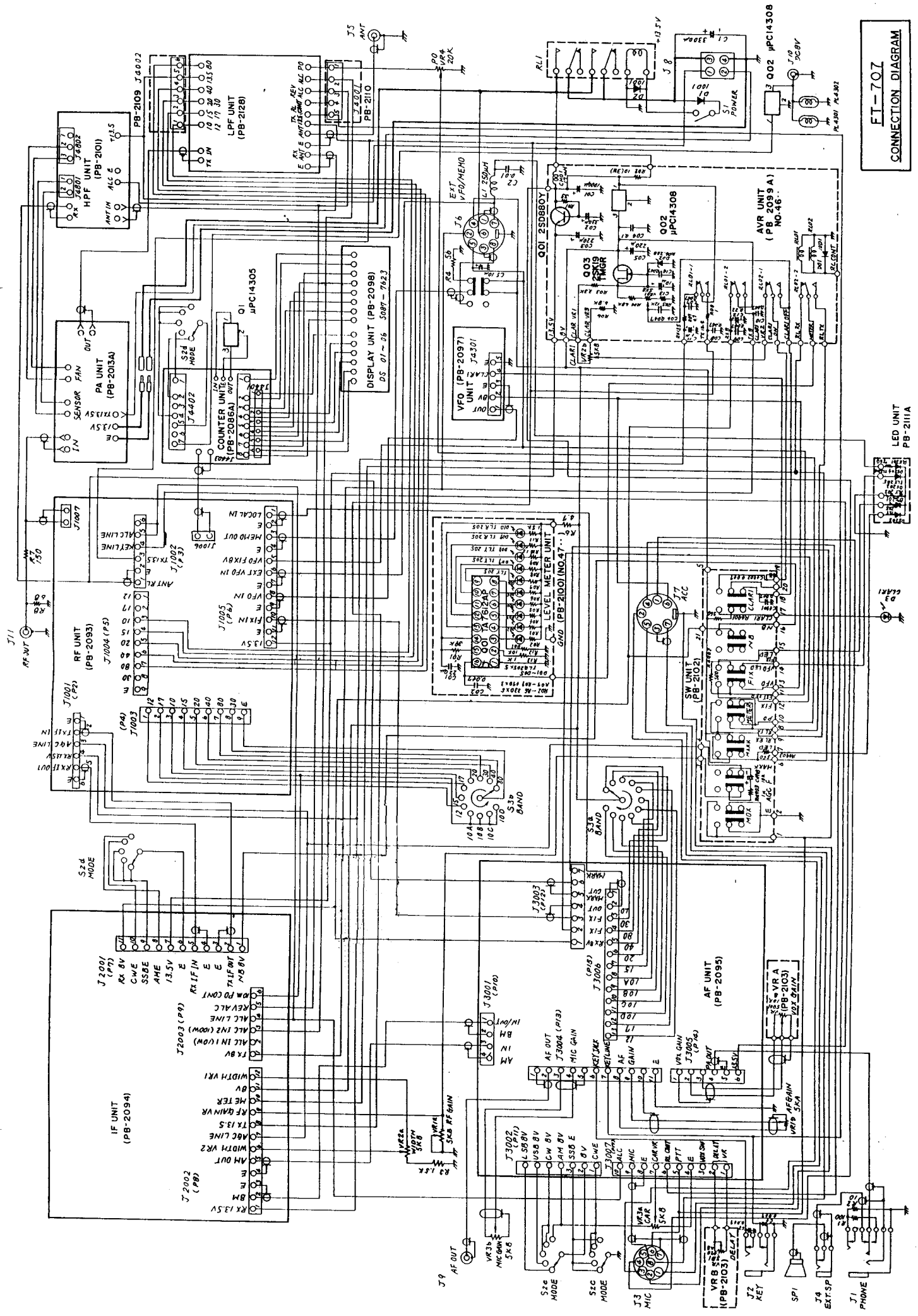

FT-70Z
CONNECTION DIAGRAM

WIRING DIAGRAM

