

YAESU

FT-415

***2-m Hand-Held
Paging Transceiver***



Table of Contents

<i>Specifications</i>	3	Transmitting	20
<i>Accessories & Options List</i>	4	Repeater Splits	21
<i>Controls & Connectors</i>		Setting Standard Repeater Offset	22
Top Panel	5	Automatic Repeater Shift	22
Side & Front Panels	6	Simple Memory Storage	23
Key Functions	9 & 10	Recalling Memories	24
<i>Accessories</i>		Call Channel Memory	24
Batteries & Chargers	11	Memory Tuning	25
NC-42 1-hour Quick Charger	11	Hiding and Erasing Memories	25
E-DC-5 Car Cig. Lighter Plug/Adapter	12	Scanning	26
FBA-12 Dry-Cell Battery Case	12	Memory Skip Scanning	27
Battery Removal & Replacement	13	Programmable Subband Limits	27
MH-12A2B & MH-18A2B Speaker/Mics	14	Priority Channel Monitoring	28
MH-19A2B Earpiece/Microphone	14	CTCSS Operation (with FTS-17A)	29
YH-2 VOX Headset with Boom Mic.	14	DTMF Paging & Code Squelch	33
Antenna Considerations	14	DTMF Autodial Memories	39
<i>Operation</i>		<i>In Case Of Problems</i>	41
Preliminary Steps	15	Memory Backup	42
Squelch Setup	16	<i>Extending Battery Life</i>	43
Frequency Selection Modes	17	<i>FTS-17A Installation</i>	47
Frequency & Step Selection	19		

FT-415 2m Hand-Held FM Paging Transceiver

The FT-415 is a deluxe compact FM hand-held for the 2-meter amateur band providing all of the latest capabilities of dual-microprocessor control. Transmitter power output is user-selectable in four levels, up to five watts (when used with a 12-volt battery pack or DC supply). The FT-415 offers a whole new range of battery preserving features, a 10-memory, 15-digit DTMF autodialler, CTCSS scanner and a wealth of selective calling/paging features designed to revolutionize FM communication.

The sculpted die-cast alloy rear case/heatsink and thick high-impact polycarbonate plastic front panel and battery cases provide professional-grade ruggedness ideal for demanding applications. Rubber gasket seals around all external controls and connectors keep out dust and rain or spray, assuring years of reliable operation even in harsh environments. The LCD (display) and translucent keypad have selectable lighting modes, and the display

shows six frequency digits and most programmable functions, plus relative signal strength and power output on a bargraph meter. A DC supply jack is provided on the top panel for powering the transceiver from an external 5.5- to 16-volt DC source, and will also charge a Ni-Cd battery pack connected to the transceiver. A 36-mm diameter loudspeaker provides low-distortion receiver audio, and VOX circuitry is included for hands-free transmit/receive control with the optional YH-2 headset.

Two independent vfos and forty-one freely tunable memories are completely programmable from the 16-key keypad, for scanning, independent tx/rx frequencies or programmable offsets, programmable sub-band limits for band scanning, selectable scan skip for busy channels, scan resume on carrier drop or after 5-second pause, priority monitoring and 1-touch instant-recall CALL channel. Channel steps are selectable from 5, 10, 12.5, 15, 20 or 25 kHz; and

always available. Automatic Repeater Shift (ARS) can be enabled to set standard repeater shifts automatically when tuned to a standard repeater subband. A 1750-Hz burst tone generator is provided in European versions (in place of squelch override in other versions). The FTS-17A CTCSS (Continuous Tone-Controlled Squelch System) is built in with the US version (optional for other versions). It provides 38 standard subaudible tones which can be stored in each memory independently. Also with the FTS-17A, a CTCSS Bell feature can be set to sound a paging alert tone when tone squelch opens, and you can scan a channel to identify CTCSS tones being used by other stations.

In addition to the 4-level power output selection and built-in battery charger, unique battery charge life extending features include Yaesu's ABS (Automatic Battery Saver), which monitors operating history and optimizes the save duration accordingly; selectable-period APO (Automatic Power Off) to turn off the radio after a period of inactivity; selectable always-on or 5-second display and keypad illumination;

and even the capability to disable the **BUSY LED** to save power.

The keypad serves as a DTMF encoder during transmission, and up to 10 DTMF memories can store 15 digits each for quick playback of commonly-used numbers. The revolutionary DTMF (Dual-Tone, Multi-Frequency) -based selective calling and private paging capabilities let you select any of 999 3-digit ID codes for your transceiver, and then have it stay quiet until your code is received (from any standard DTMF-equipped transceiver). Upon receiving the DTMF ID code, you can have a synthesized paging beeper sound (1, 3 or 5 times), and also have the squelch open, or not, as desired. Additionally, in the page mode, when your ID code and a 3-digit ID code of the calling station are received, your display shows his code, so you know who is calling. Six 3-digit code memories store your ID plus those of 5 other frequently-called stations or groups you wish to monitor, and an extra code memory always stores the last 3-digit DTMF code heard.

Please read this manual carefully to familiarize yourself with the FT-415 features.

Specifications

General

Frequency range (MHz):
144 ~ 148 (vers. A1, B2);
144 ~ 146 (vers. B1);
130 ~ 174 Rx, 140 ~ 150 Tx (vers. A2, only available where regulations permit)

Channel steps: 5, 10, 12.5, 15, 20 & 25 kHz

Std. repeater shift: ± 600 kHz (programmable)

Emission type: G3E

Supply voltage: 5.5 to 16 V DC

Current consumption:
6.5 mA Auto Power Off
8 mA Stby (Saver on);
190 mA Receive @ 7.2V,
w/200 mW AF out;
170 mA Receive @ 12V,
w/500 mW AF out;
1500 mA Transmit (5W);

Antenna (BNC jack): YHA-17 rubber helical

Case size (WHD): 55 × 146 × 33mm w/FNB-27

Weight (approx): 430 grams with FNB-27

Receiver

Circuit type: Double-conversion superhet

IFs: 17.7 MHz & 455 kHz

12-dB SINAD Sensitivity: $< 0.158 \mu\text{V}$

Adjacent channel selectivity:
> 60 dB

Intermodulation: > 65 dB

AF output (@ 12 V, for 5% THD): 0.5 W @8 Ω

Transmitter

Power output (@ 12 V): approximately 5, 3, 1.5 and 0.5 watts

Frequency stability: better than ± 10 ppm

Modulation system: variable reactance

Maximum deviation: ± 5 kHz

FM Noise (@ 1 kHz): better than -40 dB

Spurious emissions: > 60dB below carrier

AF distortion (@ 1 kHz):
< 5%, w/3.5 kHz dev.

Microphone type: 2-k Ω condenser

Burst tone: 1750 Hz (except vers. A)

Specifications may be subject to change without notice or obligation.

Accessories & Options List

Rechargeable Ni-Cd Battery Packs

FNB-25 7.2 V, 600 mAh

FNB-26 7.2 V, 1000 mAh

FNB-27 12 V, 600 mAh

FNB-28 7.2 V, 700 mAh

Compact 15-Hour Chargers

NC-18B 117 VAC, for FNB-27

NC-18C 220/234 VAC, for FNB-27

NC-28B 117 VAC, for FNB-25/-28

NC-28C 220/234 VAC, for FNB-25/-28

NC-34B 117 VAC, for FNB-26

NC-34C 220/234 VAC for FNB-26

NC-42 1-Hour Desktop Quick Charger for all
above FNB packs

FBA-12 Battery Case for 6 AA-size Dry-Cells

CLIP-3 Belt Clip

BC-1 Bottom Cover (for use without Battery)

CSC-50 Soft Case for FT-415 w/FBA-12/FNB-25

CSC-51 Soft Case for FT-415 with FNB-28

CSC-52 Soft Case for FT-415 w/FNB-26/-27

E-DC-5 Cig. Lighter DC Cable/Noise Filter

MMB-49 Mobile Hanger Bracket

MH-12A2B Hand Speaker/Microphone

MH-18A2B Miniature Hand Speaker/Mic

MH-19A2B Earpiece/In-Line Miniature Mic

YH-2 VOX Headset

YHA-17 Rubber flex antenna

FTS-17A CTCSS Subaudible Tone Squelch Unit

Availability of accessories may vary: some accessories are supplied as standard per local requirements, others may be unavailable in some regions. Check with your Yaesu dealer for changes to the above list.

Controls & Connectors



Top Panel

(1) Antenna Jack

This BNC jack accepts the supplied YHA-17 rubber flex antenna, or another antenna designed to provide 50-ohm impedance on the 2-meter band.

(2) EXT DC Jack (under rubber cover)

This 4-mm coaxial jack accepts an external source of 5.5 to 16 volts DC (center contact

positive) to operate the transceiver, and to charge a Ni-Cd battery pack if installed on the bottom of the transceiver.

Note: the protective rubber cover over the jacks must be pulled up (by the tab at the right end) to access the jacks. Press it back over the jacks when they are not in use, to protect the inside of the transceiver from dust and water.



(3) EAR Jack (under rubber cover)

This 2-conductor, 3.5-mm mini phone jack provides audio output for an optional earphone or speaker/mic (impedance is 8Ω). The internal loudspeaker is disabled when this jack is used.

(4) MIC Jack (under rubber cover)

This 2-conductor, 2.5-mm phone jack accepts microphone input from an optional microphone or speaker/mic (impedance is $2\text{-k}\Omega$). The internal microphone is disabled when this jack is used.

(5) DIAL Rotary Selector

Use this 20-position switch to tune, or select memories and other settings such as tuning steps and paging codes, according to the function selected by the keys. This knob duplicates most functions of the  and  keys for convenience.

(6) VOL/OFF Control

This control adjusts the volume of the receiver. Turn it fully counterclockwise (into the click stop) to turn the transceiver off.

(7) SQL Control

This knob sets the threshold level at which received signals (or noise) open the squelch. It should normally be set just to the point where noise is silenced (and the **BUSY/TX** lamp is off) when the channel is clear. If you disable the lamp to minimize current consumption, set this control by ear.

Side & Front Panels

(1) Monitor (Burst), PTT & Lamp Switches

The three buttons under the rubber cover are activated by pressing the ridges at the top

(Monitor/Burst) or bottom (Lamp) of the cover, or the center of the cover (PTT – Push-to-Talk).

The rubber cover over the switches is intended to be permanent, and allows the switches to be operated underneath without removal.

In the US version, the (upper) Monitor/Burst switch opens the squelch momentarily without disturbing the squelch settings. In the



European version, this switch activates the 1750-Hz burst tone generator to transmit the tone (the PTT switch does not need to be pressed to transmit the tone).

Press and hold the (center) PTT switch while speaking across the front of the transceiver to transmit (the microphone element is near the lower right corner of the panel). The **BUSY/TX** indicator glows red while transmitting, and pressing the front panel keys transmits a DTMF tone pair or sequence.

Press the (lower) Lamp switch to illuminate the display and keypad when operating in the dark. Pressing only this switch activates the lamp for 5 seconds. Press **[FM]** first if you want the lamp to stay on (until you press the switch again).

(2) Battery Release

Slide this mechanical button upward to install a battery pack,

and to release the battery for removal.

(3) BUSY/TX Indicator Lamp

This LED indicator glows red when transmitting, and, unless you disable it, green when the noise squelch is open (the channel busy) during reception.

(4) Liquid Crystal Display

The display shows current operating conditions as indicated below.

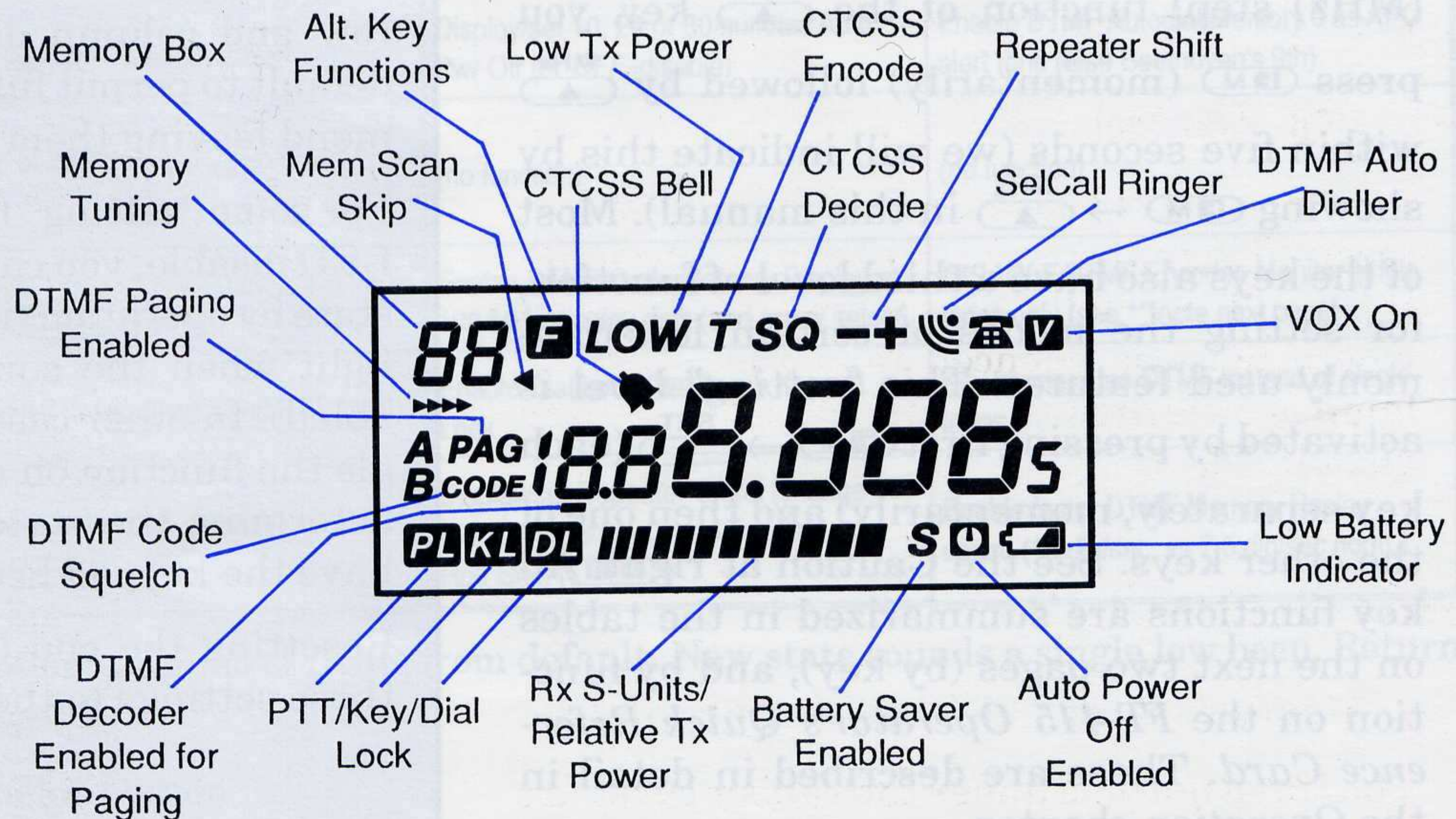

(5) 17 Rubber Keys

These keys generate DTMF tone pairs during transmission (except **DTMF(CALL)**), and select operating features of the transceiver during reception. One or two beeps sound whenever a key is pressed (unless the keypad beeper is disabled). The labels on the key-faces indicate their primary functions, while labels on the panel indicate alternate functions, which are activated by pressing **(FM)** first, and then the other key within five seconds. For example, to use the alternate (MHz) step) function of the **(▲)** key, you press **(FM)** (momentarily) followed by **(▲)** within five seconds (we will indicate this by showing **(FM)** → **(▲)** in this manual). Most of the keys also have a third level of function, for setting the modes of certain less-commonly-used features. This “setting” level is activated by pressing first **(FM)** → **(0)** (each key separately, momentarily) and then one of the other keys. See the Caution at right. All key functions are summarized in the tables on the next two pages (by key), and by function on the *FT-415 Operator’s Quick Reference Card*. These are described in detail in the *Operation* chapter.

Caution!

Many of the “setting” functions of the FT-415 provide no indication of their current state on the display. However, if the keypad beeper is enabled, changing the state of any of these functions will cause either a single, low-pitched beep to sound when the function is enabled/activated, or a high/low-pitched beep sequence to sound when the function is deactivated. The default state of most of these functions is disabled/deactivated. The two exceptions to this rule are the DTMF row and column disable functions, which default to permit full DTMF (and we recommend leaving them as is).

For some “setting” functions, such as **BUSY LED disable**, you can determine the current state by operation (if the **BUSY LED** doesn’t light when the squelch is open, it is disabled). In other cases, you may need to toggle the function on and off (or off and on) to determine the state. First make sure you have the keypad beeper enabled!

Resetting the cpu (page 42) returns all of these settings to their default states.

Key Functions

Key/Button	Normal Function	Alt Function (after EM) "E" displayed for 5 sec	Setting Function (after EM → SET 0) "SE" displayed until PTT pressed	Alt Setting Function (after EM → SET 0 → EM) "SE" displayed until PTT pressed
DTMF CALL	Jump to CALL Channel	Toggle DTMF Autodial Memory Mode ("AM")	(no function)	(no function)
TONE 1	Enter digit 1	Toggles CTCSS Encode/Decode Mode: T/(T SQ)**/off, or cancels CTCSS Tone Freq. Display, if active.	Display & toggle DTMF code transmit delay: 450 or 750 ms	Toggle 2-sec DTMF tx hang time
T SET 2	Enter digit 2	Toggle Display/setting of CTCSS tone freq. and "b" if key/button beeper enabled (DIAL and EM to change)	Display/set 1, 3 or 5 paging rings (or OFF)	Enable CTCSS tone scanning
LOW 3	Enter digit 3	Toggle High/Low Transmit Power	Display/set 10, 20 or 30 minutes Auto Pwr Off (or OFF=disable)	Enable DTMF Autodial Memory 0 as APO alert tone (else Beethoven's 9th)
MHz ▲ / ▼ MHz	Tune up/down a step or memory	Tune vfo or tunable memory up/down 1 MHz	(no function)	(no function)
SAVE 4	Enter digit 4	Display/set Power Saver interval: 1-6 keys set interval, 0 key disables	Enable DTMF Code Memory Display at 100-MHz display digit (and arrow select)	DISABLE DTMF Encoder. Monitor single tones only (see ***note next page)
LOCK 5	Enter digit 5	Lock/Unlock Keypad("KL") and PTT ("PL")	Enable Dial Lock ("DL") with Keypad Lock	Key beeper: use DTMF instead of single tones
RPT 6	Enter digit 6	Toggles Repeater Shift direction: -/+/off (simplex)	Display/set Repeater Offset (change with DIAL /arrows), and Toggle Auto Rptr Shift (EM)	Enable faster DTMF Memory Replay speed (10 dig/sec, vs 7.5 dig/sec norm.)

* Alt Setting Function descriptions assume starting from default. New state sounds a single low beep. Return to default sounds high/low beeps.

** requires FTS-17A Tone Squelch Option

Key Functions (continued)

Key/Button	Normal Function	Alt Function (after FM) “ F ” displayed for 5 sec	Setting Function (after FM → SET 0) “ SE ” displayed until PTT pressed	Alt Setting Function (after FM → SET 0 → FM) “ SE ” displayed until PTT pressed
STEP 7	Enter digit 7	Display/set tuning steps (set by DIAL) & scan pause mode (FM). PTT to return to normal	Disable/enable BUSY LED	Enable keypad entry of valid 1-kHz digits for 12.5, 20 & 25-kHz steps - to select splinter channels
VOX 8	Enter digit 8	Toggle VOX/sensitivity Hi/Low/Off (“ V ”, for YH-2 headset)	Enable “Pocket Bell” paging	DISABLE DTMF Column tones***
REV 9	Enter digit 9	Toggle Reverse Splits (in split operation only)	(no function)	DISABLE DTMF Row tones***
CODE PAGE	Activate DTMF Paging/ Code Sql/CTCSS Bell (“ PAG - CODE - ▶ ”)	Display/set DTMF Code Memories	(no function)	(no function)
SKIP MR	From vfo: recall last-used memory. From memory: enable memory tuning (“>>>>”)	From memory mode only: toggle scan skip of current memory	(no function)	(no function)
SET 0	Enter digit 0	Enable “Setting” key mode (only “ SE ” displayed)	Ringer tone test	(no function)
PRI VFO	From vfo: select vfo “ A ”/“ B ” From memory: select last-used vfo	Activate Priority Monitoring	(no function)	(no function)
FM	Enable Alt Funcs	Cancel Alternate key functions	Enable Alt Setting Key Functions	Cancel Alt Setting

*** **Warning!** These functions disable DTMF operation! Row and Column disable functions sound high/low beeps when activated (DTMF disabled). Reset to single low beep to use DTMF.

Accessories

Batteries & Chargers

The FT-415 requires the FNB-27 12-volt rechargeable Ni-Cd battery pack for the full 5-watt transmitter power output. However, where slightly lower maximum power output is practical, the FBA-12 dry-cell battery case (1.5 watts) and the 7.2-volt FNB-25, FNB-26 and FNB-28 Ni-Cd packs (2 watts) offer smaller size, lighter weight or extended battery charge life. Also, the 7.2-volt Ni-Cd packs may be recharged while attached to the transceiver, using the **EXT DC** jack on the top. Any Ni-Cd pack should be fully charged before it is used with the transceiver for the first time.

Three types of chargers are available: 15-hour compact chargers, the NC-42 1-hour Desktop Quick Charger and the 15-hour internal charging circuit powered by the E-DC-5 Cigarette Lighter Plug Adapter and an external DC voltage source.

Different 15-hour compact chargers are required for different packs:

Ni-Cd Pack	Voltage	Capacity (mAh)	Compact Charger
FNB-25/-28	7.2	600/700	NC-28A
FNB-26	7.2	1000	NC-34A
FNB-27	12	600	NC-18A

Make certain that you use the correct compact charger for each pack. Each compact charger is available with a "B" suffix for operation from 117-VAC, or with a "C" suffix for operation from 220 ~ 234-VAC.

NC-42 1-hour Quick Charger

The NC-42 is a universal AC mains battery charger with quick and trickle charging modes for all of the FNB series Ni-Cd packs listed above. It comes wired for the mains voltage in the area sold. The quick mode is automatically selected initially, to bring the battery pack up to full charge as fast as safely possible using a Δ -V sensor. A red LED lights during quick charging, and when the pack approaches full charge, the charger reverts to the trickle mode (green LED), to prevent self-discharge. The quick mode recharges a completely discharged battery in about 1 hour, depending on temperature.

E-DC-5 Car Cigarette Lighter Plug/Adapter

The E-DC-5 connects the **EXT DC** Jack on top of the transceiver to a car lighter, to provide operating and battery charging voltage from the automobile electrical system or another DC source (see box this page). Be careful to avoid overcharging. *Use only with 12-volt negative-ground electrical systems.*

FBA-12 Dry-Cell Battery Case

The FBA-12 dry-cell battery case may be used with six "AA"-size (UM-3) batteries. Maxi-

mum power output is about 1.5 watts. Use alkaline cells for best performance.

Caution! *The FBA-12 must not be used with rechargeable cells.* It lacks the necessary thermal and over-current protection circuits provided in the FNB series Ni-Cd Packs.

One or more of the above battery packs/cases may be supplied with the transceiver. If you need a battery, contact your Yaesu dealer. We do not recommend the use of any other type of battery with the FT-415, and using another type may affect your warranty.

Operating & Charging with an External DC Supply

The E-DC-5 or another cable with a 3.5-mm coaxial plug that matches the **EXT DC** Jack can be used to operate the transceiver from a source capable of providing 1.5 amperes at 5.5 to 16 VDC.

To charge a battery through this jack, the supply voltage must be at least 2 volts higher than the nominal battery voltage (9.2 volts for the FNB-25, -26 and -28, or 14 volts for the FNB-27). Charging time depends on the battery capacity and state of charge, and is typically 18 hours for the FNB-25 and -27, 21 hours for the FNB-28, and 30 hours for the FNB-26, when fully discharged. Be careful to avoid overcharging a battery pack when using an external DC supply: when a battery is fully charged, disconnect it and install a BC-1 bottom cover on the transceiver to protect it.

Battery Removal & Replacement

- ❑ Make sure that the VOL control is set into the OFF click-stop, and remove the protective soft or hard case, if used.
- ❑ Grasp the transceiver with your left hand, so your palm is over the speaker and your thumb is on the Battery Release Button.
- ❑ Move the button in the direction indicated by the arrowhead, while using your right hand to slide the battery case toward the side with the button. The battery case should slide smoothly out of its track.

To open the FBA-12 battery case, place your thumbs on the tracks on top of the case and gently pry the tracks apart. Always replace all six batteries, paying attention to the polarity indicated inside the case.

- ✗ *Do not attempt to open any of the rechargeable Ni-Cd packs, and do not install rechargeable cells in the FBA-12, as they could explode if accidentally short-circuited.*

To replace the battery case or Ni-Cd pack, repeat the second and third steps above, simply sliding the battery case in the other direction after aligning the shorter side of the battery

case with the track below the Battery Release Button.



MH-12A2B & MH-18A2B Speaker/Microphones

A Speaker/Mic can increase operating convenience and extend communications range. Each is equipped with a dual plug connector which mates with the **EAR** and **MIC** jacks on the top panel of the transceiver, disabling the internal speaker and microphone. The cable allows the transceiver to be left clipped to your belt, or to be held above obstructions for better performance. Also, using a speaker/mic for mobile operation allows the transceiver to be left in the MMB-49 Mobile Hanger.

Hold the Speaker/Mic close to your ear during reception; or connect an earphone to the plug on the Speaker/Mic, attenuating the audio from its loudspeaker. To transmit just hold the Speaker/Mic close to your mouth and close the PTT switch on the microphone.

MH-19A2B Earpiece/Microphone

The MH-19A2B works like the speaker/mics described above, but consists of an earpiece and in-line microphone/PTT switch element. The earphone is inconspicuous and ideal for monitoring in noisy or crowded areas, while the microphone has a clip for attaching to a shirt or

jacket collar. Press the PTT switch on the microphone to transmit.

YH-2 VOX Headset with Boom Microphone

The YH-2 connects to the **EAR** and **MIC** jacks in the same manner as the speaker/mics. It consists of a headband-supported earphone and attached boom microphone, allowing hands-free operation when VOX operation is activated in the transceiver.

Antenna Considerations

While the supplied YHA-17 rubber flex antenna is convenient for short-range operation, the standard BNC jack allows use of a higher gain antenna to extend range in base or mobile operation. Any antenna used with the FT-415 should have an impedance close to 50 ohms on the 2-meter band. If a feedline is used, it should be good quality 50-Ω coax. Obtaining a proper fit with some BNC plugs may require removing the rubber gasket around the antenna jack on the transceiver.

Operation

This chapter describes the various transceiver functions tutorially. After studying these descriptions, keep the *FT-415 Operator's Quick Reference Card* handy in case you need to refresh your memory.

Preliminary Steps

Before operating the FT-415 the first time:

- Charge the battery pack completely (if using Ni-Cd batteries) as described on page 11. If using an FBA-12 dry-cell battery case, install the batteries as described on page 13.
- Connect the supplied antenna to the antenna jack on the top of the transceiver. *Never operate the transceiver without an antenna connected.*
- If you have a Speaker/Mic, we suggest you not connect it until you are familiar with basic operation.
- Before proceeding, please read the *Controls & Connectors* chapter, if you have not already, to familiarize yourself with the functions of the controls. Note especially the

display on page 8, and the key information on pages 9 through 11.

When the front panel keys are pressed during reception, one or two beeps will sound to indicate key contact. Don't hold the  key down unless you are storing a memory, and don't press two keys at the same time. While transmitting, the keys generate DTMF tones according to their numeric label or the blue **A**, **B**, **C**, **D**, *****, **#** label (near the non-numeric keys).

You need not be too concerned about the following descriptions of timers - they are much easier to learn (by doing, which we will get to shortly) than to describe.

Low Battery Indicator

When battery voltage drops below about 6.5 volts,  is displayed at the lower right, indicating the battery pack should be recharged or batteries replaced. If you continue operating, the icon will blink and the transmitter will be disabled.

Key Beeper

You can toggle the key beeper on and off by pressing **[FM]** → **[T SET 2]** → **[FM]** → **[T SET 2]**. If you lock the keypad (page 18) with the beeper enabled, each key will sound a different musical note for as long as it is held.

A five-second timer starts when you press **[FM]**, and automatically restarts when you turn the selector knob or press an arrow key. Pressing other keys may shut off the timer as the resulting change in operation occurs, or start a different timer for selecting a parameter. When the “setting” mode (after **[FM]** → **[SET 0]**) is activated the display is blanked, except for “SE” appearing in the memory box. Pressing any key at this point will alter the operation of the transceiver according to the descriptions of the setting mode features. You must either press the PTT switch (no transmission will occur), or turn the set off and back on, to exit the setting mode and return the display to normal.

A beeper provides useful audible feedback whenever a key is pressed, at a level determined by the volume control. Each key has a different

beep pitch, and many functions have unique beep combinations. For example, you will hear a low-pitched beep followed by a high-pitched beep when you press **[MHz ▲]**, or a high-pitched beep followed by a low-pitched beep when you press **[MHz ▼]**. In some of the “setting” mode procedures *these beeps are the only indicator you have* of which condition is selected by a keypress. You can disable the beeper as described in the box above, but we recommend keeping it enabled while getting to know the controls, and whenever using the “setting” mode procedures.

With that said, if you have trouble getting the transceiver to work as described, see *In Case of Problems*, on page 41.

Squelch Setup

- Set the **SQL** control fully counterclockwise, rotate the **VOL** control out of the click-stop and adjust for a comfortable volume on the noise or received signal.
- The **BUSY/TX** indicator will glow green to indicate that the squelch is open, unless you have disabled it (page 44). If a signal is present, turn the **DIAL** on the top panel to a channel with only noise.

- Adjust the **SQL** just to the point where the noise is silenced and the LED is extinguished. (If the **SQL** is set further clockwise, sensitivity to weak signals is reduced.)

Now, whenever a signal reaches the receiver strong enough to open the squelch, the **BUSY/TX** indicator will glow green.

Note that while receiving, one or more bargraph segments may appear along the bottom of the display, indicating received signal strength. This is not affected by the squelch, so even squelched signals can give some indication. If several bargraph segments appear while the squelch is closed, try reducing the **SQL** setting (if you want to hear weak signals).

The squelch override switch on non-European versions (the upper ridge on the rubber cover on the left side) opens the squelch so you can check for signals beneath the squelch level, and adjust volume independently.

Frequency Selection Modes

VFO Mode

This mode is for tuning or scanning the band when looking for a channel on which to operate, when you don't have a specific frequency in

mind. In this mode, the selector knob and arrow keys each tune the band in the selected step size, or in 1-MHz steps, and the scanning function tunes in the selected step size. The FT-415 has two independent vfos, A and B, which you toggle between by pressing PRI VFO when receiving on either vfo. The display shows which vfo is currently selected at the far left.

Memory Mode

This mode is mainly for operating on specific channels known in advance (and stored in the memories). For example, after storing the frequencies of your local repeaters into memory channels, you can confine operation to those channels by selecting the memory mode. In this mode, the **DIAL** knob, arrow keys and scanning function select sequentially from stored memories. The FT-415 has 41 memories, each of which can store repeater shift direction, CTCSS settings (if the FTS-17A option is installed), and separate receive and transmit frequencies.

Each memory has a *Memory Tune* mode, in which you can tune just like the vfo mode, and store the resulting retuned memory into the same or another memory. This and other special memory mode functions are described later, but you will want to keep these terms in mind.

You can tell at a glance which frequency selection mode is active by looking in the shaded memory box at the upper left corner of the display. If the box is empty (and a small “A” or “B” appears below the box), you are in the vfo mode. If you see a small number or an “L”, “U” or “C” in the box, you are in the memory mode.

The SKIP / MR key activates the memory mode from the vfo mode, and PRI / VFO activates the vfo mode from the memory mode. While in the memory mode, your previous vfo mode selections are preserved. Also, when you switch between vfo and memory modes, the last-selected memory or vfo is always the one recalled.

Keypad, PTT & Dial Locking

The PTT switch, keys and **DIAL** knob can each be “locked” (disabled), to prevent inadvertent transmissions or adjustments. You will find **PL**, **KL** and possibly **DL** displayed at the bottom left corner when any of these are locked. Whether any locks are active or not, you can always press FM → LOCK / 5 to gain control of the locks for 3 seconds, during which you can press LOCK / 5 again repeatedly to step through the locking combinations, and off (no indicator).

If you want to also lock the **DIAL** knob, you need to enable this function by pressing FM → SET / 0 → LOCK / 5 (once, if you hear one low-pitched beep). After this, **KL** **DL** appear together whenever you lock the keypad, indicating that the **DIAL** knob is locked too.

Remember, to disable all locks regardless of state, press FM → LOCK / 5 and then LOCK / 5 again as many times as necessary to clear the lock indicators.

You will want to enable the locks if you hand the radio to someone who might disturb your settings. Pressing the keys while locked causes different musical notes to sound for as long as the key is held, but only the unlocking sequence affects operation.

Frequency & Step Selection

You can select a new operating frequency from a vfo, or by tuning a memory. For now, we suggest using the vfo mode. If you see a memory number in the memory box, press $\overset{\text{PRI}}{\text{VFO}}$ to switch to vfo mode. You can enter a new frequency directly by the numeric keys, or by tuning with the DIAL knob or $\overset{\text{MHz}}{\blacktriangle}$ and $\overset{\text{MHz}}{\blacktriangledown}$. See the box on the previous page if the keys or knob don't work.

Direct Numeric Keypad Entry

To enter a new frequency directly, just press the 1's-of-MHz digit, and the 100's- and 10's-of-kHz. When you press the first key, the displayed frequency will clear, and only the new digit will appear. When you press the last key, the display will revert to normal, showing the new operating frequency to 6 digits (if it was valid), or the original frequency (if it was not: 2 beeps sound).

Example: To operate on 146.94 MHz:

Press $\overset{\text{RPT}}{6}$ → $\overset{\text{REV}}{9}$ → $\overset{\text{SAVE}}{4}$

If your set covers the 146- to 147-MHz range, you should now see "146.940" displayed as your operating frequency. Otherwise, you should have heard 2 beeps, and the display should be as before (try an in-band frequency).

If your version is using 12.5- or 25-kHz steps, *nothing happened* when you pressed $\overset{\text{SAVE}}{4}$, since this frequency cannot be accessed with these steps. Just press any other number (except $\overset{\text{REV}}{9}$) to get the nearest resulting 12.5-kHz channel. Notice that you can enter 12.5-kHz splinter channels this way, but subsequent tuning will still be in the selected step size, if it is larger (see below).

Don't worry if you get stuck, you can always press the PTT to cancel your entry and return to the previous display.

Tuning

You can turn the DIAL or press the arrow keys to tune in the selected step size. If you

Tuning Splinter Channels

If you use 12.5-, 20-, or 25-kHz tuning steps and want to have keypad access to 5-kHz channels, you can enable a 4th key during keypad entry: press [M] → $\overset{\text{SET}}{0}$ → [M] → $\overset{\text{STEP}}{7}$ and then the PTT switch. Note that even if you enable this, the splinter channeling is cancelled when you retune.

press and hold an arrow key for continuous tuning, you will need to release it and then press it again momentarily (to stop, and pre-

Transmitter Power Selection

Press **[FM]** → **[LOW 3]** to select either high, or one of three low power settings: “L1”, “L2” or “L3” (displayed for 3 seconds). Also during selection, the bargraph meter indicates the relative power level. Note that the lowest level draws the least current, and so provides the longest battery charge life.

To change the low power level, press **[FM]** → **[LOW 3]** and **[LOW 3]** again if “Hi” is displayed. Then turn the **DIAL** or use the arrow keys to choose a low level. Press the PTT or wait 3 seconds for the display to return to normal.

	@7.2 volts (approx)		@12 volts (approx)	
	watts	mA	watts	mA
L1	0.5	400-800	0.5	600
L2	1.5	500-1000	1.5	850
L3	2	500-1000	3	1100
Hi	2	1000	5	1500

vent scanning). One-MHz steps are also available: just press **[FM]** before pressing either of the arrow keys (and hold the arrow key for repeated stepping), or press **[FM]** and turn the **DIAL**.

Default channel (tuning) steps are 5 kHz in A versions, and 25 kHz in B versions. To select another step size, press **[FM]** → **[STEP 7]**, turn the **DIAL** for the desired steps, and then press **[STEP 7]** again to return to normal operation.

Transmitting

Press **[FM]** → **[LOW 3]**, once or twice so that “LOW” appears at the top of the display to select low power output (see box).

To transmit, wait until the channel is clear (**BUSY/TX** LED off), then squeeze the PTT switch on the side of the transceiver while speaking into the microphone (near the bottom right of the front panel). During transmission the **BUSY/TX** indicator glows red, and the bargraph shows relative transmitter power output. Release the PTT switch to receive.

If you need more power to maintain communications, you can select another power setting as described in the box. However, we recommend using the lowest power level necessary to

maintain communication to both maximize battery life and minimize possible interference to other stations.

If using a European version, press the upper ridge of the rubber pad on the left side (just above the PTT switch) to transmit a 1750-Hz Burst Tone to access repeaters that require it.

Repeater Splits

The FT-415 offers three methods to set up split transmit/receive operation for repeaters: manual, automatic and independently-stored tx/rx frequencies. Both manual and automatic methods shift the transmit frequency above or below the receive frequency by a programmable offset, preset at the factory to 600 kHz. Note that only one offset at a time can be used with the manual and automatic methods. Use the independent transmit frequency method when you want to store other offsets, such as frequencies of repeaters with non-standard splits. This is described later under *Storing Independent Transmit Frequencies*.

To activate the standard shift manually, just press $\text{[FM]} \rightarrow \overset{\text{RPT}}{\text{6}}$ for minus shift, and press $\overset{\text{RPT}}{\text{6}}$ again for plus shift, and again to return to simplex. A small “-” or “+” sign appears near the

top center of the display to indicate the current shift direction, when activated.

Example: To operate through a 146.34/146.94 MHz repeater (or substitute another pair if this is not used in your area):

- Tune the display to 146.94 MHz (to receive on the output frequency).
- Press $\text{[FM]} \rightarrow \overset{\text{RPT}}{\text{6}}$ once. A “-” should appear at the top of the display (if not, press $\overset{\text{RPT}}{\text{6}}$ again until it does).
- When the channel is clear, press the PTT switch and send your callsign. The display shifts to 146.34 MHz while you transmit.

Of course this example only works if the offset is set to 600 kHz, as supplied from the factory. You can change it as described next.

With repeater split activated, you can temporarily reverse transmit and receive frequencies by pressing $\text{[FM]} \rightarrow \overset{\text{REV}}{\text{9}}$. Use this to display the transmit frequency without transmitting, and to check the strength of signals on a repeater uplink frequency (to see if you can work them direct). The repeater shift sign blinks while reverse split is selected. Press $\text{[FM]} \rightarrow \overset{\text{REV}}{\text{9}}$ again to return to the normal shift direction.

Setting Standard Repeater Offset

As just mentioned, repeater offset is preset to 600 kHz. If you need to change the offset, first read the following steps, and then try them:

- Press **[FM]** → **[SET 0]** → **[RPT 6]** to display the current offset in MHz, to three decimal places.
- Select the desired offset with the **DIAL** knob or arrow keys. Resolution is 50 kHz.
- Press the **PTT** to return to normal display.

You probably want to keep the repeater offset programmed to the most commonly used split in your area. If you're not sure what that is, leave it set to 600 kHz.

Automatic Repeater Shift

The ARS (Automatic Repeater Shift) feature in the FT-415 activates repeater offset automatically whenever you tune to the standard re-

peater subband. With this feature enabled, a small “-” or “+” at upper center of the display indicates that repeater shift is active (without your having to activate repeater shift manually), and closing the PTT switch changes to the (shifted) transmit frequency. The subband range over which ARS operates is determined by the version of your set, as shown below.

The ARS function is disabled at the factory. To enable it:

- Press **[FM]** → **[SET 0]** → **[RPT 6]** to display the ARS status (along with the repeater shift offset) in place of the primary frequency. An “A” appears to the left of the shift offset number when ARS is enabled.
- Now you can press **[FM]** (alone) to toggle ARS on and off.
- Press the **PTT** switch to return the display to the operating frequency.

Automatic Repeater Shift - Repeater Subbands

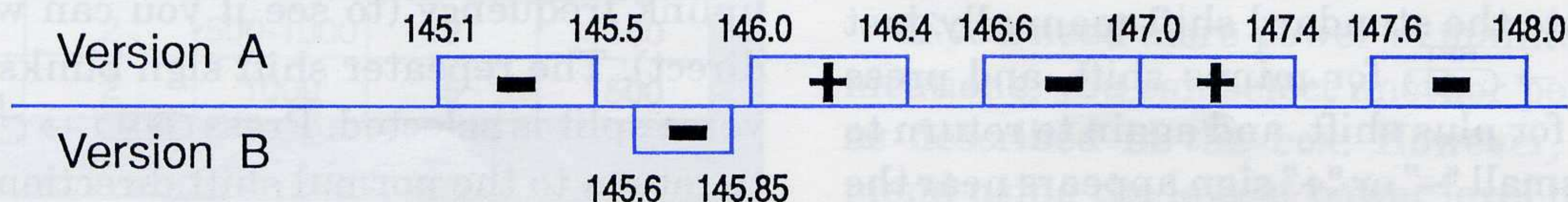

As already mentioned, you can use the manual shift method ($\text{EM} \rightarrow \overset{\text{RPT}}{\text{6}}$) at any time to select a new shift state, whether ARS is activated or not. However, if you change frequency with ARS activated, manual repeater shift selections are cancelled.

Simple Memory Storage

The FT-415 offers 41 programmable memory channels, labelled 1 through 38, L, U and C. Each can store separate receive and transmit frequencies or repeater shift, and CTCSS tone data (if the FTS-17A option is installed). Memory C (the CALL channel memory) can be recalled instantly by the DTMF CALL button at the upper left, and memories L and U can be used to store programmable subband limits, described later, in addition to general purpose operation.

To store a frequency in memory:

- Select the desired frequency (and repeater split manually, if desired) in the vfo mode as already described.
- Press and hold EM for $\frac{1}{2}$ -second (until a second beep sounds). A memory number or letter appears blinking in the memory box for the selected band.

- Within five seconds of pressing EM turn the DIAL or press $\overset{\text{MHz}}{\blacktriangle}$ or $\overset{\text{MHz}}{\blacktriangledown}$ to select the desired memory for storage. If you select one that was already being used, it will be overwritten with new data in the next step.
- Press EM once more momentarily to store the displayed data into the selected memory. The memory label will stop blinking for a second, and then disappear as operation continues in the vfo mode.

If you timed out, nothing new will have been stored in the memory. Simply start again.

Example: Store the 146.34/146.94 repeater data in memory 5.

- First perform the steps in the example on page 19 to set up the desired frequency and offset on the vfo.
- Press and hold EM for $\frac{1}{2}$ -second to display the memory label (blinking) in the memory box, then do the next step within 5 seconds.
- Turn the selector knob or press the arrow keys, if necessary, so that “5” (the memory number to store) blinks in the memory box.
- Press EM again, momentarily. That’s it. The vfo data has been stored in memory 5, and you are left operating on the vfo.

To confirm that this worked, turn the **DIAL** to change the vfo frequency (to anything new), then press **SKIP** **MR** to change from vfo to memory mode. The numeral 5 should appear in the memory box, and 146.94 (the receive frequency) should appear on the display. As mentioned before, you can press **FM** → **REV** **9** to confirm the transmit frequency of 146.34 MHz.

You can use any memory (except C, the CALL channel) with the same result. Memory C requires a slightly different procedure. Notice that pressing **SKIP** **MR** from the vfo mode always recalls the *last stored or used* memory.

Recalling Memories

In confirming the results of the last example, we used **SKIP** **MR** to change from the vfo mode to the memories after they were stored. The memory label appears in the memory box at the upper left corner of the frequency display whenever operating on a memory.

When more than one memory has been stored, you can select a memory for operation with either the selector knob or the **MHz** **▲** and **MHz** **▼** keys. If you use the arrow keys, press and release the key for each memory: if you hold the key down for 1/2-second, memory scanning will

start. In any case, only prestored memories are displayed: empty memories are skipped. To exit the memories and return to the last-used vfo, press **PRI** **VFO**.

Call Channel Memory

Although invisible to the memory recall methods just described, the CALL channel memory can be instantly recalled by the **DTMF** **CALL** button: "C" appears in the memory box. The factory default for the CALL channel memory is the bottom edge of the band. You can reprogram it with any frequency and repeater state, or even a separate transmit frequency.

To store the current vfo frequency/repeater state in the CALL channel memory, hold **FM** for 1/2-second to display something in the memory box, then press **DTMF** **CALL**. To store a separate transmit frequency in the CALL channel, after storing the receive frequency, tune the vfo to the transmit frequency and repeat the above, but this time *holding* the PTT switch *while* you press **DTMF** **CALL**.

Storing Independent Transmit Frequencies

All memories can store an independent transmit frequency, for operation on repeaters with non-standard shift. To do this:

- Store the receive frequency using the method already described under *Simple Memory Storage* (it doesn't matter if a repeater offset is active).
- Tune to the desired transmit frequency.
- Press and hold **[M]** for 1/2-second to display a label in the memory box again.
- Press and *hold* the PTT switch while pressing **[M]** once more momentarily (this does not key the transmitter).

Whenever you recall a separate transmit frequency memory, “- +” appear together near the top center of the display. Again, you can press **[M]** → **[9]**^{REV} to display the transmit frequency, and the shift symbols will blink. You can also press **[M]** → **[6]**^{RPT} to cancel repeater shift (temporarily, until you change channels).

After storing a memory with a separate transmit frequency, if you rewrite the receive frequency in the same memory, the separate transmit frequency is deleted.

Memory Tuning

While receiving on a recalled memory, you can retune it and change other memorized settings (like repeater shift) by first pressing **[SKIP MR]**. A line of four tiny arrowheads (“>>>>”) appears under the memory label in the memory box, and you can tune in the same ways as described before (including 1-MHz steps). You can store the new frequency and settings in the current, or another memory. Just press and hold **[M]** for 1/2-second, select the new memory (if desired), and press **[M]** again momentarily. Operation remains on the (new) memory as the old memory reverts to its original state.

After retuning a memory, if you don't want to save your changes, just press **[SKIP MR]** to return to the original memory data.

Hiding and Erasing Memories

As already mentioned, storing data into a memory overwrites previously stored data. However, if you regularly move from one area to another, you may want to use different memories in different places or at different times. With the FT-415, you can choose to make available different sets of memories without having to rewrite them from scratch. This is done by

masking certain memories so that they are hidden from operation, and unmasking them only when desired.

To mask a memory,

- Recall the memory to be masked.
- Press and hold **[M]** for 1/2-second (until the memory label blinks).
- Press **[SKIP MR]**. This causes the display to change to the next lower (stored) memory, and the previously selected memory to be no longer selectable manually, or by scanning (described later).

To unmask a hidden memory for operation,

- Recall any memory.
- Press and hold **[M]** for 1/2-second (until the memory label blinks).
- With the selector knob or arrow keys, select the memory number to be restored.
- Press **[SKIP MR]** (not **[M]**!).

When you have hidden some memories, be careful not to overwrite them accidentally. If you do, you will not be able to recover the previous contents.

Scanning

Before starting the scanner, make sure the **SQL** control is set to squelch off the noise on a clear channel. You start and stop scanning with the **[MHz ▲]** or **[MHz ▼]** key. Just press and hold either key for more than 1/2-second to start the scanner. If the transceiver is in the vfo or memory tune mode, band scanning will result. Otherwise, in normal memory mode, only the memories will be scanned.

The scanner pauses when a signal opens the squelch, and the decimal point on the display blinks. When band scanning, a double beep will sound each time the scanner reaches the band edge, unless you have disabled the beeper (**[M]** → **[T SET 2]** → **[M]** → **[T SET 2]**). Scanning resumes according to how you set the scan resume mode, described in the box on the next page.

You can stop the scanner manually by pressing the PTT switch, **[MHz ▲]** or **[MHz ▼]** key, which will leave operation on the current frequency. Scanning is also halted by **[SKIP MR]**, **[PRI VFO]** or **DTMF [CALL]**, but operation shifts to the respective new frequency, in these cases.

Memory Skip Scanning

When you have some very active channels stored in memories you may wish to skip them when scanning, but still have them available for manual selection. You can mark a memory to be skipped by pressing \boxed{M} → $\boxed{\text{SKIP MR}}$ while receiving on the memory. A “◀” just outside of the lower right corner of the memory box indicates that this memory will be skipped during scanning (although you can still recall it manually).

To undo the scan-skip state of a memory, just repeat the steps you took to disable it: select the memory manually, and press \boxed{M} → $\boxed{\text{SKIP MR}}$.

Programmable Subband Limits

Besides band and memory scanning, the FT-415 can be set to tune or scan only the frequencies between two frequency limits of your choice (with the selected channel steps). These limits are stored in the special memories labelled *L* (lower) and *U* (upper):

- Store the lower edge of the desired scanning range in memory *L*, and the upper edge in memory *U*.
- With either memory *U* or *L* recalled, press $\boxed{\text{SKIP MR}}$ to enable memory tuning, as described

previously (“>>>” must be visible below the memory box). The frequencies stored in memories *L* and *U* now limit your tuning and scanning range to the resulting subband. If either ARS or manual repeater shift is activated, repeater offset is applied automatically when you transmit (even if the resulting transmit frequency is outside the subband limits).

Scan Resume Mode Selection

You have a choice of two scan-resume modes: either *Pause* mode, in which the scanner pauses for as long as the carrier keeps the squelch open; or the *5-second* mode, in which the scanner pauses for five seconds and then resumes scanning whether the signal is still present or not. The 5-second mode is the factory default.

To display the scan-resume mode, press \boxed{M} → $\boxed{\text{STEP 7}}$. A small “*p*” or “*5*” in the memory box indicates the current mode. Press \boxed{M} again to toggle the mode, and $\boxed{\text{STEP 7}}$ again to return to normal display.

Note: The frequency resolution of subband limits is 100 kHz, although the channel resolution of memories L and U is the selected channel step size. Therefore the actual subband limits are the frequencies stored in these memories *rounded down* to the nearest 100 kHz. Since the memories themselves are not limited to a specific frequency, you can still use them for other purposes on any frequency within the 100-kHz range above the intended subband limit.

Example: To limit reception to 145.0 ~ 145.9 MHz

- Tune a vfo to *any channel between 145.000 and 145.095 MHz.*
- Hold [M] for $\frac{1}{2}$ -second, tune the selector knob so that L appears in the memory box, and then press [M] again momentarily. The displayed frequency is now stored to provide a lower subband limit of 145.000 MHz.
- Retune the vfo to any channel between 145.900 and 145.995 MHz.
- Repeat the second step, selecting U in the memory box. This stores the effective upper subband limit of 145.900 MHz.
- Press $\text{[MR]}^{\text{SKIP}}$ to change to memory operation, and $\text{[MR]}^{\text{SKIP}}$ again to activate the 145.000 ~

145.900 subband limits for tuning and scanning. Note that when scanning the subband, as with band scanning, a double beep sounds each time the scanner reaches the subband edge, unless you have disabled the beeper ($\text{[M]} \rightarrow \text{[2]}^{\text{T SET}} \rightarrow \text{[M]} \rightarrow \text{[2]}^{\text{T SET}}$).

To release subband limits press $\text{[MR]}^{\text{SKIP}}$ to return to memory operation, $\text{[VFO]}^{\text{PRI}}$ to return to a vfo, or DTMF [CALL] to switch to the CALL channel.

Once the L and U memories are stored you can reactivate the subband just by recalling either memory and pressing $\text{[MR]}^{\text{SKIP}}$ again. However, you cannot activate the subband if either of these memories is marked for skip-scanning, or masked (hidden).

Priority Channel Monitoring

The priority function automatically checks for activity on a memory every five seconds while operating on a vfo or other memories. When the receiver detects a signal on the priority memory, operation automatically shifts to that memory while the signal is present (plus a few seconds). If you transmit while paused on the priority memory, priority monitoring ceases and operation stays on the priority memory.

To set up priority monitoring:

- Preset the squelch, and store the frequency to be monitored in a memory (this must be memory 1 if you will be operating on other memories during priority monitoring).
- Press $\overline{\text{VFO}}^{\text{PRI}}$ to operate in the vfo mode, or else select the memory you want to operate on, and then press $\overline{\text{M}} \rightarrow \overline{\text{VFO}}^{\text{PRI}}$.

A “P” appears in the memory box, and about every five seconds the displayed frequency shifts to the priority memory briefly while the receiver checks for a signal.

As long as no signal appears on the priority memory to open the squelch, you can tune, transmit and receive on the vfo, or select other memories (memory labels are displayed only while changing). If a station you wish to talk with appears on the priority memory, press the PTT switch momentarily while receiving their signal, to stop priority checking. Otherwise, when a signal appears on the priority memory, priority checking will pause and the decimal on the display will blink. Priority monitoring will resume according to how you set the scan-resume mode — either after a 5-second pause, or after the carrier drops. To cancel priority monitoring manually, press $\overline{\text{VFO}}^{\text{PRI}}$.

Note that you can use any memory (besides memory 1) as a priority channel in the above procedure when you are going to be operating in vfo mode. You cannot, however, switch vfos, or between memory and vfo operation, without first cancelling priority monitoring (pressing $\overline{\text{MR}}^{\text{SKIP}}$ or $\overline{\text{VFO}}^{\text{PRI}}$ cancels priority monitoring).

CTCSS Operation (with FTS-17A)

The FT-415 can be used to access repeaters that require a CTCSS (continuous, subaudible) tone, and to silently monitor for calls on busy channels, when the optional FTS-17A CTCSS Unit is installed. The encode (“T”) function superimposes a subaudible tone (at a frequency too low to be heard) on the transmitted carrier. The decode (“T SQ” — tone squelch) function monitors receiver audio through a narrow filter at the same subaudible frequency, keeping the squelch closed until you receive a matching tone. Installation instructions are on page 47.

To check or set the current CTCSS tone frequency, press $\overline{\text{M}} \rightarrow \overline{\text{2}}^{\text{T SET}}$ to see the tone frequency displayed in Hz. To change the selected tone frequency, turn the DIAL selector or press $\overline{\blacktriangle}^{\text{MHz}}$ or $\overline{\blacktriangledown}^{\text{MHz}}$ until the display shows the tone frequency you require (the display will step

through the standard EIA tones, listed in the table below). Press $\overline{\text{T SET 2}}$ again alone to return to the operating frequency display when the desired tone frequency is displayed.

To activate CTCSS functions press $\overline{\text{FM}} \rightarrow \overline{\text{TONE 1}}$ when the operating frequency is displayed. With one press, "T" (encode) appears at the top of the display and the tone generator is activated for transmission. Press $\overline{\text{FM}} \rightarrow \overline{\text{TONE 1}}$ again (or just $\overline{\text{TONE 1}}$ if the alternate key functions are still active) and both "T" and "SQ" (decode) will be displayed together as the tone squelch system is activated for both transmit and receive (only incoming signals "encoded" with the matching tone frequency open the squelch).

FTS-17A Tone Frequencies (Hz)			
67.0	100.0	141.3	203.5
71.9	103.5	146.2	210.7
74.4	107.2	151.4	218.1
77.0	110.9	156.7	225.7
79.7	114.8	162.2	233.6
82.5	118.8	167.9	241.8
85.4	123.0	173.8	250.3
88.5	127.3	179.9	
91.5	131.8	186.2	
94.8	136.5	192.8	

Pressing $\overline{\text{FM}} \rightarrow \overline{\text{TONE 1}}$ once more turns off tone squelch features.

You can store CTCSS tones (and encode/decode states) in each memory in the same manner (and at the same time) as storing operating frequencies. To change the tone or state stored in a memory, just recall it, reset the tone frequency or function, and store the memory again (press and hold $\overline{\text{FM}}$ for 1/2-second, release it, and press it again momentarily). If you activate CTCSS on one of the subband limit memories, it will be active when *that* memory is used to start subband operation.

CTCSS Tone Scanning

If you hear signals which you suspect (or know) are using CTCSS, but you don't know what tone frequency is being used, you can activate CTCSS scanning to determine the frequency of the tone(s). To enable CTCSS scanning, press $\overline{\text{FM}} \rightarrow \overline{\text{SET 0}} \rightarrow \overline{\text{FM}} \rightarrow \overline{\text{T SET 2}}$ and listen for the resulting beep(s). If you hear one low-pitched beep, CTCSS scanning is enabled. If you a high-low beep sequence, press $\overline{\text{T SET 2}}$ again while **F** is still at the top of the display (or else press $\overline{\text{FM}} \rightarrow \overline{\text{T SET 2}}$ if it is not). In either case, press the PTT when done.

Once CTCSS scanning is enabled, you can activate it on the current channel frequency:

- Activate CTCSS Tone Squelch (FM) \rightarrow $\overset{\text{TONE}}{\text{1}}$ and then $\overset{\text{TONE}}{\text{1}}$ again, if necessary, until “TSQ” is displayed).
- Press FM \rightarrow $\overset{\text{T SET}}{\text{2}}$ to display CTCSS tone frequency.
- Press and hold $\overset{\text{MHz}}{\blacktriangle}$ or $\overset{\text{MHz}}{\blacktriangledown}$ for $\frac{1}{2}$ second to begin scanning.

The scanning speed is very rapid when no signal is present, and slows down to several tones/second when a signal appears, as the signal is checked for a CTCSS tone. When the scanner matches the tone, as shown on the display, scanning will pause as the decimal on the display blinks. Press the PTT to stop CTCSS scanning at this point, and the displayed tone will remain selected. Otherwise, when the received carrier drops, CTCSS scanning will resume until another signal is received, or until you press the PTT to terminate CTCSS scanning (no transmission will occur).

Press $\overset{\text{T SET}}{\text{2}}$ to return to the frequency display. Now when you transmit or store a memory, the scanned tone will be used.

“CTCSS Bell” Paging

CTCSS Bell operation is an extension of the CTCSS encode/decode function described above: incoming subaudible tones open the squelch. However, it adds two features to make this type of semi-private operation more convenient:

- The CTCSS Bell mode displays “” near the center of the display. When you receive a matching CTCSS tone this bell blinks to indicate you received a call. So by looking at the display you can tell if a call came in while you were busy with something else. You cannot tell, however, who called. That requires the DTMF Paging mode, described later.
- If you are waiting for a call, it is sometimes convenient to have the transceiver “ring” to get your attention. By activating the ringing function, you can have the transceiver ring like a telephone (in a variety of ways – see the box on the next page).

Note: The *CTCSS Bell* function described here and the “*Pocket Bell*” mode of DTMF Paging, described in the section after this, are entirely different functions.

To activate the CTCSS Bell:

- Tune to the desired frequency.

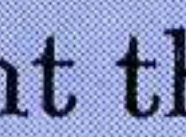
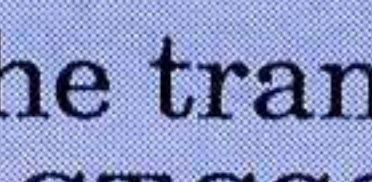
- Select a CTCSS tone frequency ([FM] → [T SET 2]) as described starting on page 29, if you have not already.
- When you expect to receive calls from stations using tone squelch (decoding, or CTCSS Bell), activate tone squelch encode/decode (“**TSQ**”) operation as described above, so you will not miss calls when you turn off the CTCSS Bell later to reply.
- Press [CODE PAGE] three times to select the CTCSS Bell mode. This cycles through the following paging mode/displays:
 - DTMF paging (“**PAG**” displayed at the left, and “” near the upper right if the ringer is enabled),
 - DTMF tone-coded squelch (“**CODE**” displayed at the left),
 - CTCSS Bell paging (“” displayed if the FTS-17A is installed, and “” near the upper right if the ringer is enabled), and
 - No paging (none of the above symbols).

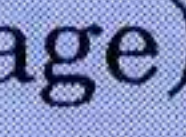
Now all incoming calls without a matching CTCSS tone will be ignored by your receiver. Any call received with the matching CTCSS tone will cause the “” to blink and the transceiver to ring (if the ringer is enabled) as the squelch opens

Ringer Alerting Tone

If you want the transceiver to ring when a selective call (CTCSS Bell, or DTMF Page) is received, check for “” displayed near the upper right when either of these features is active. If present, the ringer is enabled.

If enabled, you can check the current ring sound by pressing [FM] → [SET 0] → [SET 0] . Press the PTT to return to normal display.

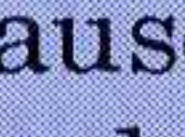
To change the on/off state of the ringer or number of rings, press [FM] → [SET 0] → [T SET 2] , and if you like, press [T SET 2] again repeatedly to select display of **OFF**, **1**, **3** or **5** rings (you will see “” displayed if not **OFF**). Then press the PTT switch to return to normal display.

When the ringer is enabled with CTCSS Bell or DTMF Paging, the first incoming call will cause the ringer to sound, and after you reply, the ringer will sound again each time the squelch opens. To prevent this, you can disable either the ringer (set to **OFF**) or switch to normal CTCSS tone squelch (**TSQ**) operation by pressing [CODE PAGE] .

while the caller transmits. The “♥” continues to blink until you manually reset it (by pressing the PTT switch to transmit, retuning, or pressing $\overline{\text{SKIP MR}}$ or $\overline{\text{PRI VFO}}$ to change channels). Note that other stations do not need to be using the CTCSS Bell function to call you: they can use normal CTCSS encode-only (or encode/decode) functions of their transceiver.

When you reply to a CTCSS Bell call, you will probably want to turn off the CTCSS Bell function, since otherwise the transceiver will ring every time your squelch opens (unless, of course, you have disabled the ringer). Just press $\overline{\text{CODE PAGE}}$ once to turn it off. If you have set up normal tone squelch operation beforehand, you will be able to continue your QSO.

You cannot store the CTCSS Bell mode selection in a memory; although you can store different CTCSS tones and encode/decode states.

DTMF Paging & Code Squelch

The FT-415 includes a DTMF tone encoder/decoder and a dedicated microprocessor providing paging and selective calling features under DTMF control. This allows you to place a call to a specific station or group, and to receive calls directed only to you or groups of your choice.

The paging and code squelch systems use 3-digit numeric codes (000 ~ 999), transmitted as DTMF (Dual-Tone, Multi-Frequency) tone pairs. There are eight Code Memories numbered 0 ~ 7 (entirely independent of the 41 channel memories and the vfos) which store 3-digit DTMF paging codes.

In typical applications, the receiving station remains silent until it receives three DTMF digits which match those stored in one of its code memories. Then the squelch opens so the caller is heard, and in the paging mode, the ringer can be set so the transceiver also rings like a telephone (see the box on the previous page). When you close the PTT to transmit, the same three prestored DTMF code digits are transmitted automatically. In the paging mode, three more DTMF digits are sent, representing the 3-digit identification code of the transmitting station.

Like the CTCSS Bell system described above, the DTMF paging and code squelch systems are selected by pressing $\overline{\text{CODE PAGE}}$. Either “PAG” or “CODE” appears on the display when DTMF paging or code squelch is activated, respectively. Details of the code squelch and paging modes are provided next.

DTMF Code Squelch

The code squelch mode is very simple: both you and the other station communicate using the same 3-digit DTMF sequence, sent automatically by the FT-415 at the start of every transmission. Your receiver normally remains silent to all signals that are not prefixed by your selected 3-digit code. When you receive the matching tone sequence, your squelch opens and stays open until a few seconds after the end of their transmission.

In the code squelch mode, you must first store and then manually select the one Code Memory holding the 3-digit DTMF code required to open your squelch (as described on the following pages). Also, in the code squelch mode, Code Memories 1 ~ 6 always function the same — the distinctions and special settings described below for the paging mode do not apply.

In either code squelch or paging modes, any DTMF-equipped station can call you. They can use a DTMF keypad to send the three digits if you are in code squelch mode, or seven digits (actually, three digits--“star”--three digits, eg. 123*456) if you are in paging mode.

DTMF Paging

In the DTMF paging mode, you can receive signals that are prefixed with any of up to six different 3-digit codes, according to the method you choose when programming the Code Memories. When you receive a paging call, the selected Code Memory changes automatically, and the display responds in one of two ways, depending on which of the following two methods you used to store the paging code:

Individual Codes

These are personal ID codes to identify each station uniquely. You store one of these for your ID, in Code Memory 1. You can store up to five other Individual Codes of stations you call often, in Code Memories 2 ~ 6. When someone else transmits your Individual Code your transceiver automatically selects Code Memory 0, and the calling station's Individual Code is installed in that Code Memory so you can see who called (see the box on the page after next for code display options).

Group Codes

This type of code identifies a group of stations. You would generally share a Group Code

with other club members or friends. When you receive a call with a Group Code the Code Memory number (2 ~ 6) in which you stored that 3-digit Group Code is selected and displayed automatically, so you can see which group has been called (if you have stored more than one).

Note that for a Group Code, the display does not show the ID and code of the caller, but those of the group instead. Code Memories 2 ~ 6 can be used to store either Individual Codes (for calling purposes only) or Group Codes (for both calling and receiving), as you desire.

With either type of page, the *PAG* indicator starts blinking when a page is received, and the ringer sounds, if enabled. The blinking indicator lets you know if someone called while your attention was elsewhere.

Remember, with code squelch operation (but not with paging), you can only receive a call on the currently-selected Code Memory, and the display does not change when a call is received. So for code squelch, as mentioned before, the Individual/Group distinction does not apply (although you must still store the 3-digit Code Memories).

DTMF Code Monitoring

Whenever a 3-digit DTMF code is received while either code squelch or DTMF paging is active, the code is automatically written into Code Memory 7. By selecting this Code Memory as described below, you can determine what DTMF code was last heard, whether or not it opened your squelch.

Storing Code Memories

The first thing to do before using the paging or code squelch systems is to store your Individual Code in Code Memory 1.

Press **EM** → **CODE PAGE** to enable the Code setting mode. The frequency display is replaced by a small



Code Memory number at the left, and the corresponding 3-digit Code ("000", if not used before) at the right.

Turn the **DIAL** to select Code Memory 1 (this digit can be set to 0 ~ 7, with 0 and 7 being "read-only", and 2 ~ 6 programmable with group or other individual's IDs). Code Memory 1 is for your personal DTMF paging ID Code.

- Referring to the numeric keys, enter the three digits (each 0 ~ 9) of the DTMF Code to store.

Your ID Code is now stored in Code Memory 1. You can use the same procedure to store the Memory Codes of other individuals or groups in Code Memories 2 ~ 6, but with an additional feature: generally you store another station's ID Code so you can page them, but do not want to have *your* transceiver ringing every time someone else calls *them*. On the other hand, you store group codes with the intention of receiving any pages to the group (so you want your squelch to open and the transceiver to ring, if paging).

During the Code Memory storage procedure described above, when storing Code Memories 2 ~ 6, you have an opportunity to decide whether your transceiver should respond to incoming paging calls on a particular Memory Code. After pressing $\text{[FM]} \rightarrow \text{[PAGE]}^{\text{CODE}}$ to activate Code setting you can press the [FM] key to toggle DTMF squelch paging capability on and off. When on, that is, when the decoder is enabled to receive paging calls with this Code Memory, a tiny underbar appears beneath the Code Memory digit.

If you are setting a Group Code, you want to have the underbar on, and if setting another

Code Display Options

Normally, DTMF Codes are only displayed after you press $\text{[FM]} \rightarrow \text{[PAGE]}^{\text{CODE}}$, or after you receive a call, and you can only select Code Memories when they are displayed. However, if you are using these features a lot, you may prefer to enable the alternate Code Memory display feature, which displays the Code Memory number in place of the 100's- and 10's-of-MHz frequency digits whenever Code Squelch or DTMF Paging is enabled (the rest of the frequency digits remain as before). Also, when this display feature is enabled and one of these modes are active, the [▲]^{MHz} and [▼]^{MHz} keys select Code Memories, instead of tuning (DIAL operation remains unchanged).

To toggle this Code Memory display mode on and off, press $\text{[FM]} \rightarrow \text{[0]}^{\text{SET}} \rightarrow \text{[4]}^{\text{SAVE}}$ and the PTT to return to normal operation.

station's Individual Code, you want it off. As already mentioned, this distinction does not apply to code-squelch-only (non-paging) operation — the underbar will have no effect.

Note that the underbar is displayed permanently on Code Memory 1, since this is your own ID (that you will always want to receive when paging is activated). Also, the underbar never appears on Code Memories 0 or 7, since these slots are reserved for display of incoming codes.

Once you have stored your own ID Code in Code Memory 1, you can activate the paging or code squelch functions from the normal frequency display by pressing $\overline{\text{CODE PAGE}}$. As mentioned earlier in the CTCSS Bell procedure, repeatedly pressing this key cycles through DTMF paging (“PAG” displayed), code squelch (“CODE” displayed), CTCSS Bell paging (“♥” displayed), and no paging (none of the above symbols).

Replying to a DTMF Page, and Resetting

Now you are ready to receive DTMF Paging calls directed to you. Any DTMF-equipped station can call you by sending your 3-digit code, followed by their 3-digit ID Code. If you monitor with the code squelch activated (“CODE” displayed), your squelch will open when you receive your ID Code. If you are monitoring with the DTMF Paging feature activated (“PAG” displayed), the transceiver reacts according to how you stored your Code Memories, as described above. The transceiver rings unless you have

Pocket Bell Paging

You can use the DTMF paging mode to duplicate the function of a “Pocket Bell Voice Pager”, that is, receipt of your DTMF code (stored in Code Memory 1) can cause the ringer to sound (if enabled) and the *PAG* indicator to blink, but *not* open the squelch. This can be convenient if you are in a situation where a voice call would be inappropriate. To enable the DTMF Pocket Bell function (that is, to disable the squelch opening on receipt of a DTMF page), press $\overline{\text{EM}} \rightarrow \overline{\text{SET 0}} \rightarrow \overline{\text{VOX 8}}$ (you should hear a single low-pitched beep) and the PTT switch to return the display to normal. Press the same key sequence to re-enable the squelch (a high- and low-pitched beep sequence).

turned off the ringer, as described in the box on page 32. Also see the box above on *Pocket Bell Paging*.

If you press your PTT switch after receiving a call, the Code (either Individual or Group) is transmitted automatically, and if paging is enabled, your ID Code is sent too.

To respond to an individual call, where your display shows Code Memory 0, pressing your PTT switch causes your transceiver to transmit your ID Code, a DTMF “star” (*) and the other station’s ID Code automatically (that is, the one displayed in Code Memory 0), and resets the pager to receive another call.

You may want to switch from paging to code squelch mode once contact is established. Just press **CODE** **PAGE** once, so that “CODE” appears. Either you or the other station will also have to select Code Memory 1, so that you will both be using the same DTMF code (either, but not both, must reselect their Code Memory). This can be done easily if the *Code Memory Display Option*, described in the box on page 36, is activated: just press **MHz** **▲**.

With Code Squelch activated in this manner, you will hear three DTMF code digits transmitted when you press your PTT switch. These are the digits stored in the Code Memory currently selected (and displayed in place of the 100’s-of-MHz digit if the Code Memory Display option is enabled), and they will open the squelch of the other station. Therefore, at the start of each transmission, you must wait a second or two after pressing the PTT switch for the DTMF code to be sent (you will hear it in your speaker).

DTMF Code Delay

When calling other stations with DTMF paging or code squelch, particularly through repeaters, you may find some are unable to receive your calls. This can be caused by their receiver squelch not opening fast enough (after receiving your carrier) to allow all of the DTMF digits to be received and decoded. To correct this problem, you can set a longer delay between the time your transmitter is activated and the time that the first DTMF digit is transmitted.

Press **FM** → **SET** **0** → **1** and then **1** again, if desired, to select either 450 or 750 ms delay. Press the PTT to return the display to normal.

When you finish your conversation, if you need to reactivate DTMF Code Paging, press **CODE** **PAGE** three times until “PAG” is again displayed.

DTMF Autodial Memories

The FT-415 provides ten memories, numbered 0 through 9, for storage of DTMF tone sequences of up to 15 digits each, to be used for remote DTMF control sequences or telephone numbers for autopatching systems.

A special mode must be activated to use the DTMF memory features. This mode is toggled on and off by pressing **FM** → DTMF **CALL**. A “**A**” is displayed above the rightmost frequency digit when this mode is active.

To store a DTMF memory:

- Press **FM** → DTMF **CALL**, if necessary, to display the “**A**”.
- Press and hold **FM** for ½-second (until the second beep sounds).
- Within 5 seconds of the last step, press a numbered key corresponding to the DTMF memory number you want to store. The display will change to that shown at the right.
- Again press and hold **FM** for ½-second (“**A**” begins to blink), and then key in the numbers of the DTMF sequence you want to store. As you do so, the serial

digit number in the center of the display will increment automatically as the entered code is displayed at the right.

Note: when entering new DTMF codes, the serial digit number on the display will be that of the next digit to be stored - not the serial number of the digit displayed at the right!

If you make a mistake press the PTT switch to cancel your entries, and repeat this step (all digits must be re-entered).

- If you are storing fewer than 15 digits, press DTMF **CALL** briefly to terminate entry (if you are storing 15 digits, entry will terminate automatically after the last digit). To replay the stored codes in the loudspeaker and on the display, press the numbered key corresponding to the memory number stored. You can also press **MHz** **▲** and **MHz** **▼** to display each digit manually (with the actual digit number

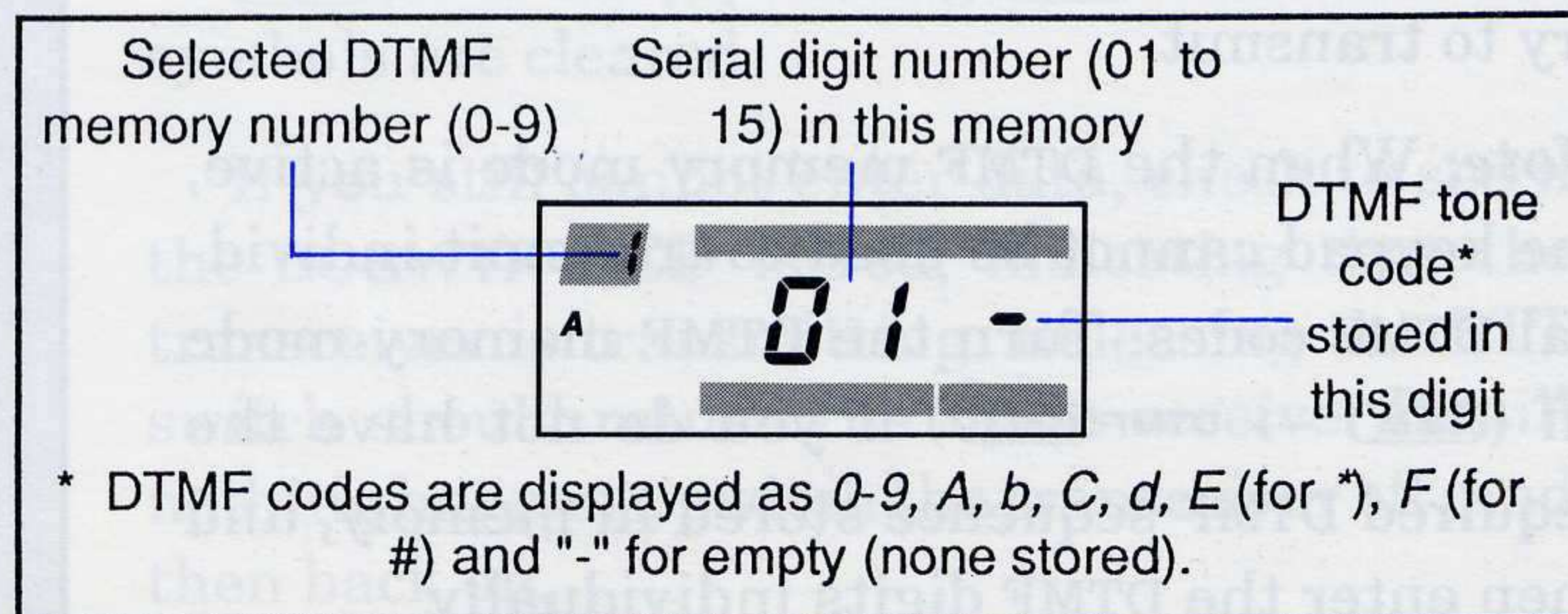

in the center of the display, and its DTMF code at the right).

- ❑ Turn the **DIAL** knob to select another DTMF memory to store, if desired, and repeat the last two steps.
- ❑ Press DTMF **(CALL)** to return to the frequency display.

To check the contents of any or all DTMF memories while “**A**” is displayed, just hold **(FM)** for 1/2-second and press any numbered key (to change the display to DTMF memories), then turn the **DIAL** knob to select the DTMF memory number in the memory box at the upper left, and use the arrow keys to display each digit.

To recall a stored DTMF memory on the air, first make sure the DTMF memory mode is activated (“**A**” is displayed). Then close the PTT switch and press the number of the DTMF memory to transmit.

Note: When the DTMF memory mode is active, the keypad cannot be used to transmit individual DTMF codes. Turn the DTMF memory mode off (**(FM)** → DTMF **(CALL)**) if you do not have the required DTMF sequence stored in memory, and then enter the DTMF digits individually.

7 Auxillary DTMF Features

The Alternate Setting functions of 7 keys provide a few useful choices regarding the DTMF keypad. Press **(FM)** → **(SET 0)** → **(FM)** and then the key indicated below to toggle the corresponding feature. Then press the PTT to return the display to normal.

DTMF transmitter hang time (**(TONE 1)**): enable to keep the transmitter keyed for 2 seconds when entering single DTMF digits.

Use DTMF Memory 0 for APO Alert (**(LOW 3)**): enable this if you prefer to store your own tone sequence for the Auto Power Off alert (instead of Beethoven’s 9th).

Use DTMF tones instead of single-tones for keypad beeper (**(LOCK 5)**).

Use fast DTMF Memory Playback (**(RPT 6)**): selects 10- instead of 7.5-digits/sec default.

Disable DTMF Keypad (**(SAVE 4)**), or DTMF rows (**(REV 9)**) or columns (**(VOX 8)**): we recommend you not change these.

In Case Of Problems

Don't worry if you find FT-415 operation somewhat complicated at first. There are many more features than the display can indicate, and most keys have more functions than are indicated by their labels. So it is not difficult to get lost, at least until you have had the chance to learn the various functions of the display and keys. This section provides some tips to help you navigate the various display and key modes.

If the display shows nothing at all, check the power switch (**VOL** control), and if necessary, remove the battery pack and check that the contacts are clean. If all appears to be physically in order, recharge or replace the batteries.

The state of the display tells a lot (but not all) about the current state of operation. The display can take on a great many different states, but most of them are temporary and will time out after a few seconds, returning to the operating frequency. Exceptions are the displays for the "setting" mode, DTMF Code Memories and CTCSS tone frequency (if the FTS-17A is installed, page 30).

Fortunately, the display includes many symbols and function indicators to let you know what is going on as long as power is applied, so it is well worthwhile to study the display diagram on page 7 carefully. For example, if the frequency display changes unexpectedly when you transmit (or if "**Err**" appears), check for a small "+" or "-" near the top center of the display, indicating repeater shift is enabled.

Attempting an illegal command (such as activating the tone squelch when the FTS-17A is not installed), will usually do nothing, and no beep will sound. However, nothing happens when you press a key for even legal commands if the keys are locked: check for "**KL**" (key lock) or "**PL**" (PTT lock) at the bottom left corner of the display. If you see one of these, press **(FM)** → **(5)**^{LOCK}, and keep pressing **(5)**^{LOCK} until the lock symbols are cleared.

If you still cannot enter data, check to see if the **BUSY/TX** LED is red, indicating that the transceiver is transmitting. Releasing the PTT switch should return the set to receive. If still nothing happens, switch the transceiver off, and then back on.

If the 100's-of-MHz digit is weird (that is, not 1) or behaves strangely when you try to tune, check for either "PAG" or "CODE" at the left side of the display, indicating that DTMF paging or code squelch is active with the code memory display option. If so, press ^{CODE}PAGE, several times if necessary, to clear these symbols and return the frequency display to normal.

If the display is almost completely blank, except for "SE" in the memory box, you have entered the "setting" mode. Press the PTT switch to clear thing to normal.

As a last resort, if you are unable to gain sensible control of the transceiver, reset the CPU as described in the next section.

To avoid confusion resulting from inadvertent button presses, set the keypad lock on as described on page 18 if you leave the transceiver unattended while it is on. Remember to set the lock back off when you wish to enter data.

Resetting the CPU

The FT-415 can be reset from the keypad to clear all settings, memories, channel step and repeater shifts to their factory defaults. Just press and hold both SKIP^{MR} and PRI^{VFO} together while turning the transceiver on.

Memory Backup

Normally, a lithium cell inside the transceiver retains all settings and memories while power is off or disconnected. If this battery ever needs replacing, the transceiver will be found to have lost its memories, although it will still operate properly.

The photo below shows the battery location on the inside of the front panel. It should be replaced only by an Yaesu-authorized technician to ensure that it is installed properly.

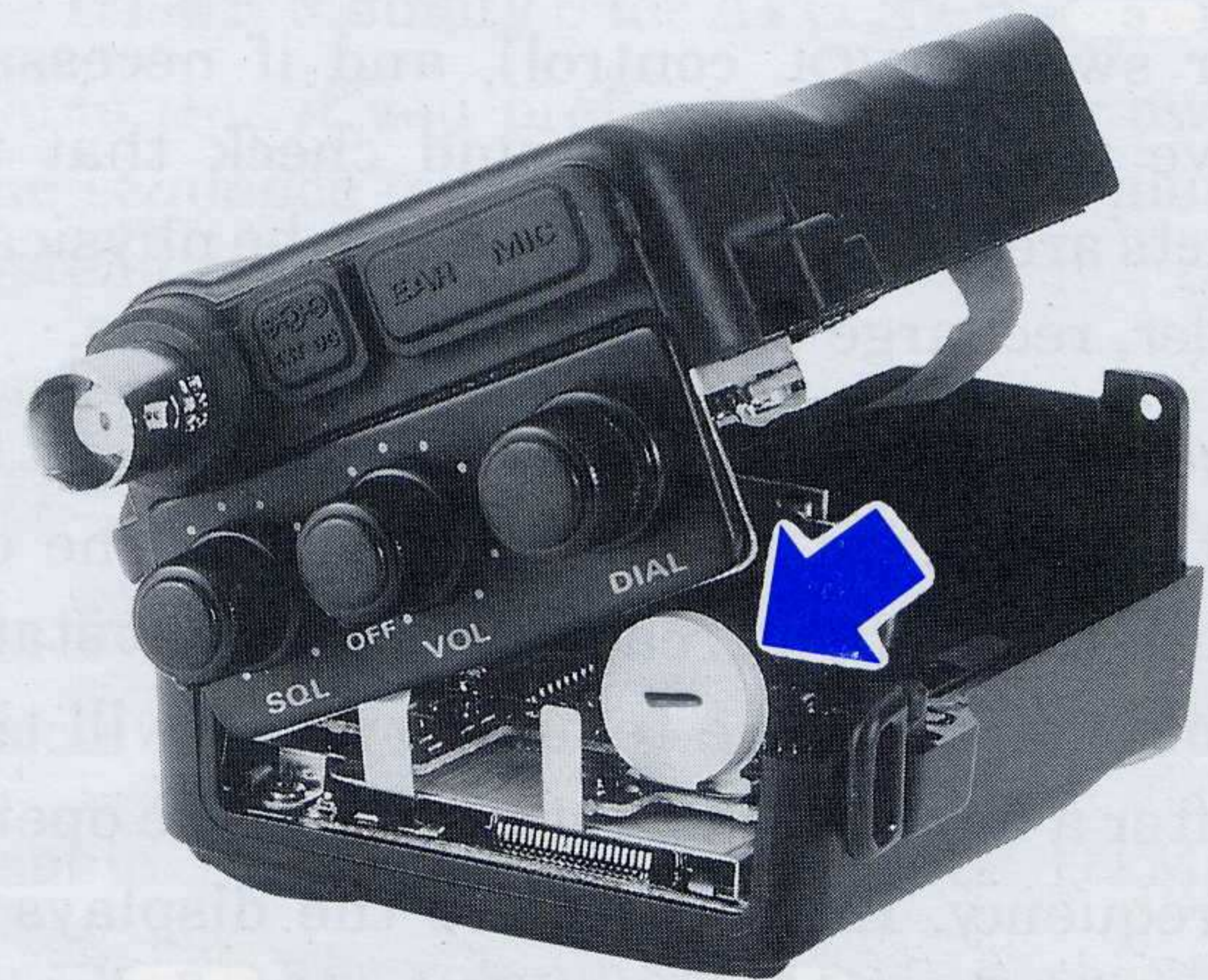

CR1220-VJ2H

Extending Battery Life

How long the batteries last between charges or replacement depends largely on your operating habits, and how you care for the battery pack (if using a Ni-Cd pack). The FT-415 offers a variety of ways to conserve battery power, and thus to extend the life of each charge. Knowing how to use these features can be critical in emergencies.

APO (Automatic Power-Off)

Obviously, turning the set off when not in use saves battery life, and can also prevent damage that might result to the batteries if they are over-discharged. The FT-415 provides the APO system to turn itself off after 10, 20 or 30 minutes of key inactivity. As shipped from the factory, APO is disabled, but you can easily activate it by pressing **[FM]** → **[SET]** → **[0]** → **[LOW]** → **[3]** and then **[LOW]** → **[3]** again repeatedly to choose the time-out time (in minutes). Then press the PTT to return the display to normal. When APO is activated, “**⏻**” appears near the bottom right corner of the display, and a timer starts every time you press a key. If you don’t press any keys for the selected time-out period, and *as long as you are not*

scanning or priority monitoring, the “**⏻**” begins to blink, and if you have the key beeper activated (page 16), it will play a few bars of Beethoven’s “Ode to Joy” (to let you know that it’s about to turn off). If you don’t press a key in the next 30 seconds, the transceiver turns (almost) off — actually, everything is turned off except for the display, which shows “**OFF**”. After that, you must switch the transceiver off and back on for use. If you need to monitor for a long period, or if using an external DC supply, you can deactivate the APO feature by pressing the same keys as above, so the display shows “**OFF**”.

Automatic Battery Saving

Monitoring with squelch closed requires about one third the power of listening to un-squelched noise, so you will naturally want to keep the squelch closed as much as possible. The FT-415 uses a new high-speed version of the Battery Saver system originated by Yaesu, reducing current drain by another factor of five during squelched monitoring. The Battery Saver turns off the receiver three seconds after the squelch closes, and then turns it on for 30

milliseconds periodically to check for incoming signals. When the Battery Saver is enabled, a small "S" appears near the bottom right corner of the display, which blinks when the saver is functioning. In the FT-415, you can select from five sleep durations, from 30ms to 1sec, or you can select the enhanced Power Saver function called ABS (Automatic Battery Saving), which senses how often the squelch opens and dynamically selects a monitor/sleep ratio according to recent operating history.

The ABS mode is enabled as supplied from the factory. You can check or change the sleep duration or disable the Power Saver by pressing **[M]** → **[SAVE 4]**, and then pressing one of the numeric keys 1 through 6 to change the current (displayed) sleep duration. Possible selections and their corresponding keys are shown below. We suggest keeping the Power Saver enabled

Key	Sleep time (ms)	On:Off	Key	Sleep time (ms)	On:Off
TONE [1]	30	1:1	LOCK [5]	1000	1:33
T SET [2]	100	1:3.3	RPT [6]	ABS	variable
LOW [3]	300	1:10	SET [0]	none	always on
SAVE [4]	600	1:20			

when operating with a battery, but when you use the FT-415 for packet, you should disable it.

BUSY LED & Beeper Disable

The BUSY function of the **BUSY/TX** LED is intended to help you set the squelch control, and to indicate when the channel is busy, so you don't transmit on top of other signals. However, it draws about 5 milliamperes when lit, and thus can contribute significantly to battery drain when monitoring an active channel. If you need to preserve power in such circumstances, you can disable the **BUSY** function of the LED:

- Press **[M]** → **[SET 0]** → **[STEP 7]**. A single, low-pitched beep indicates the **BUSY** LED is now disabled, while a high-low beep combination indicates the **BUSY** LED is enabled.
- Press **[STEP 7]** again if you want to return the **BUSY** LED function to what it was before.
- Press the PTT (to return to normal display).

You can toggle the state of the **BUSY** LED at any time by pressing the same keys again.

Similarly, the keypad beeper draws several milliamperes when enabled, so you may want to disable it (press **[M]** → **[T SET 2]** → **[M]** → **[T SET 2]**) if you need to conserve power while using the

keys a lot. However, keep in mind that the non-displayed “setting” functions require the beeper to be enabled in order to get the audible feedback that indicates their states, so you may want to re-enable the beeper (with the same key sequence) before changing these functions.

Selective Calling

Obviously, if the operating frequency is quiet the squelch will not open often and power drain will be minimized, particularly if the Power Saver is active. Unfortunately, it is not always possible or practical to confine your activity to quiet frequencies. The DTMF selective calling (code squelch, and DTMF paging) features in the FT-415 can be used to essentially make a quiet channel out of an otherwise busy one. When either of these features is active, the squelch will only open (and the **BUSY/TX** LED light, if enabled) when a signal is prefixed by a 3-digit DTMF code that matches one you have stored in the DTMF Code Memories (see page 35). This can extend battery life considerably.

In cases where you may need to monitor many stations, or some that are not equipped with DTMF encoders but do have CTCSS, the FTS-17A Tone Squelch option can also be used to make a quiet channel on a crowded frequency.

VOX, Speaker/Mics & Earphones

When actually receiving a signal, using the lowest possible volume setting minimizes current drain. You can hold the transceiver up to your ear and reduce the volume to the minimum, but it may be more convenient to use an earphone (or the MH-19A2B Earpiece/Mic) and keep the transceiver clipped to your belt, particularly in noisy environments. If you want to have both hands free, use the YH-2 Headset and activate VOX (Voice-actuated transmit/receive switching) operation by pressing **[M]** → **[8]**^{VOX}, and then **[8]**^{VOX} again, if necessary, so that the display shows either “*Hi*” (if operating in a quiet environment) or “*Lo*” (if in a noisy environment). The Hi/Low display indicates VOX amplifier gain (sensitivity). The display returns to normal a few seconds after you select the VOX state, and a small “**V**” appears in the top right corner of the display when VOX is enabled. Press the same keys again (so that “*OFF*” is displayed) to turn the VOX off when not using the YH-2.

Transmitter Power

If power conservation is important, you should use the lowest transmitter power possible to maintain adequate communications. As

described on the box on page 20, the FT-415 offers a choice of four levels of power output: one “*Hi*”, and three low — “*L1*”, “*L2*” and “*L3*”.

Notice that the current drain of the *L1* setting is about 40% of the *Hi* setting, so it is good to develop the habit of always using the lowest setting possible, switching to high power only when low power fails to get through. If you live in a location where high power is almost always needed, consider using a higher gain antenna instead of opting for high power (the effect on transmissions is the same). Make sure any external antenna is designed for 50 ohms impedance at the operating frequency.



Battery Care

As the battery discharges, the voltage drop when transmitting increases. When battery voltage drops to around 6.5V, “” appears at the bottom right, indicating the batteries should be replaced or recharged. As battery voltage drops further, the indicator begins to blink, and transmission (and operation of the controls) will fail.

If using rechargeable batteries, switch the transceiver off as soon as the indicator begins to blink. Leaving it on could over-discharge the cells and destroy the pack. On the other hand, recharging Ni-Cd batteries often with little use

between charges can degrade the charge capacity and useful life of the cells. To avoid these problems, use the battery pack just until the low battery indicator comes on, and then immediately give the pack a full recharge. Since it is hard to know exactly when the charge will run out, you may want to carry an extra, fully-charged pack with you to avoid having operation interrupted.

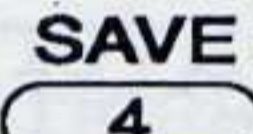
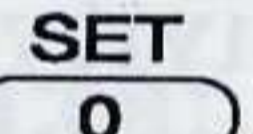
Connections for Packet Radio

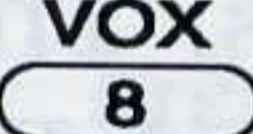
To use the FT-415 for packet, the power saver and VOX must be disabled: press  →  →  to disable power saving, and if “” is displayed, press  →  until it disappears. Connect the **EAR** and **MIC** jacks to your TNC as shown below. **MIC** jack impedance is 600 ohms, and maximum input is 300 mVrms. **EAR** jack impedance is 8 ohms, and maximum output is 2 Vrms (w/12-V supply).

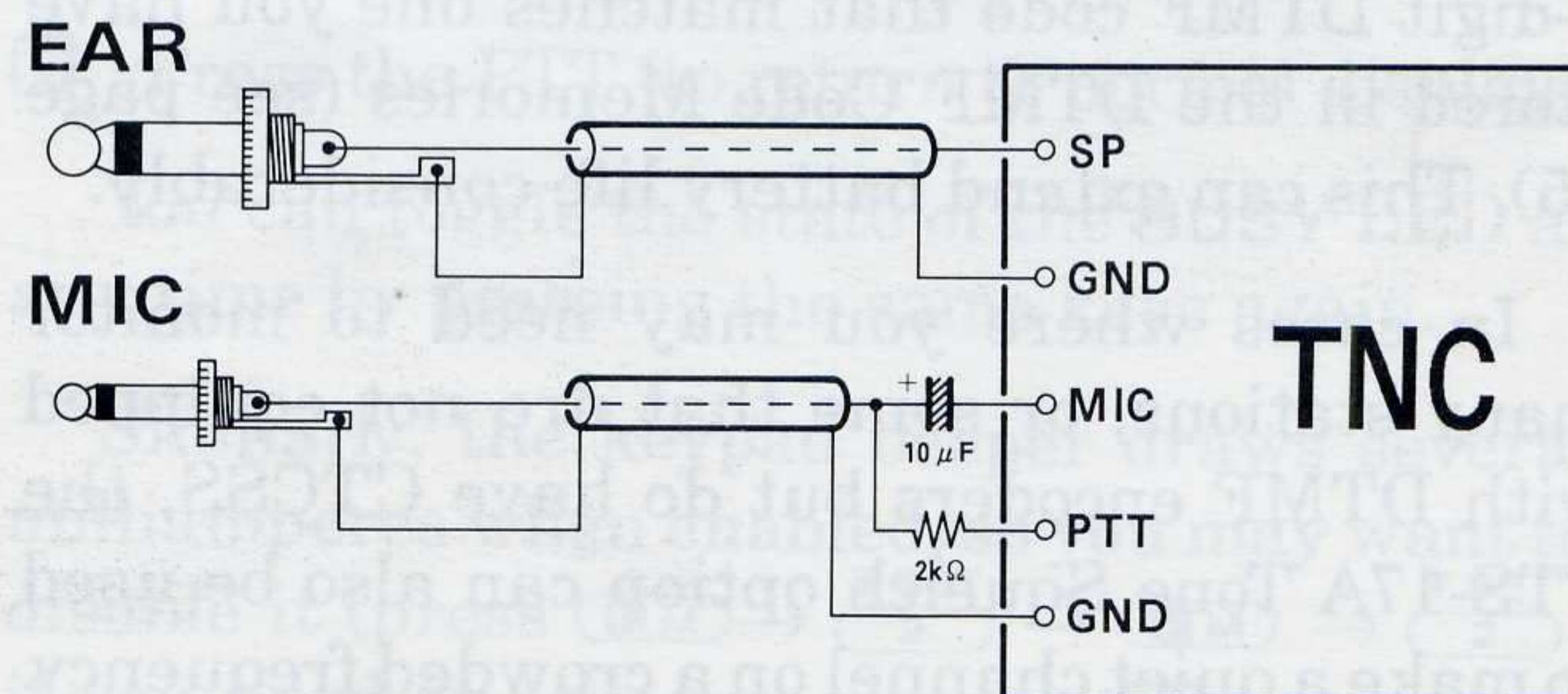

FTS-17A Tone Squelch Unit Installation

The FTS-17A is a subaudible CTCSS (Continuous Tone-Controlled Squelch System) Encoder/Decoder, which offers programmable selection of 38 tones for transmission, and matching filter/detectors for reception. Transmit-only ("T", or encode) and transmit/receive ("T SQ", or encode/decode) modes are selectable from keys on the transceiver. Installation is described here, while Tone Squelch operation is described beginning on page 29.

- ❑ Make sure the transceiver is off. Remove the hard or soft case, if used, and the battery pack as described on page 13.

- ❑ Remove the four screws affixing the battery mounting plate on the bottom of the transceiver and carefully lift and then rotate the plate 180°.
- ❑ Locate the empty 10-pin connector inside the bottom of the transceiver, and press the FTS-17A onto it as shown below, solder side out.
- ❑ Replace the battery mounting plate and its four screws, and the battery pack.

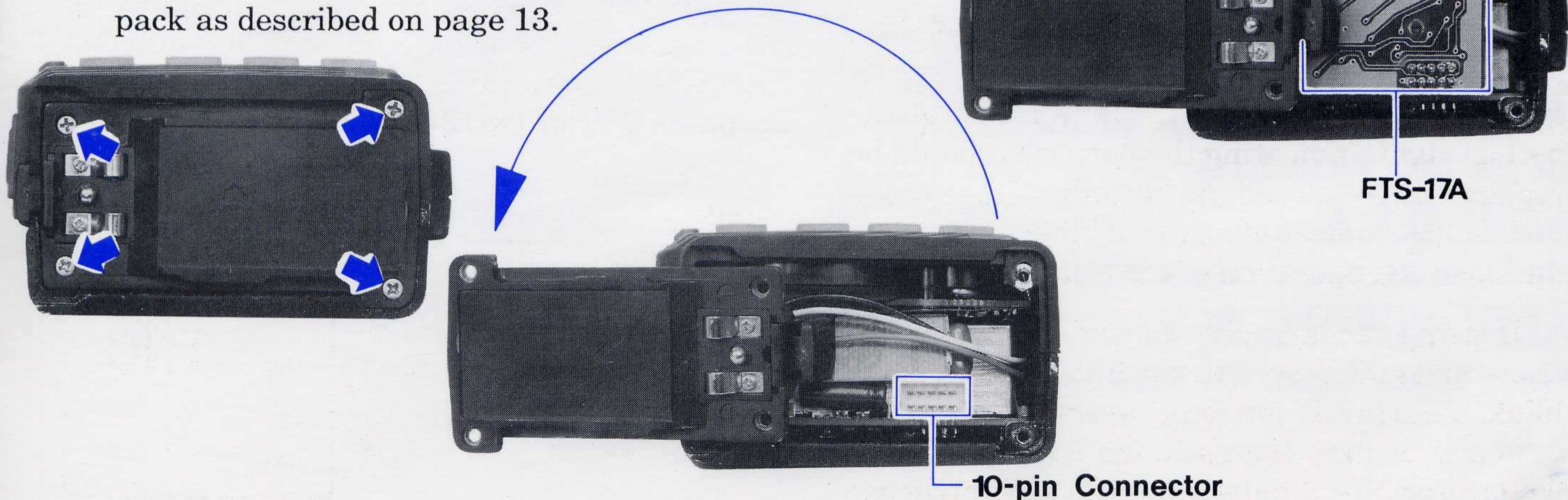



YAESU MUSEN CO., LTD.

C.P.O. BOX 1500, TOKYO, JAPAN

YAESU U.S.A.

17210 Edwards Rd., Cerritos, California 90701, U.S.A.

YAESU EUROPE B.V.

Snipweg 3. 1118AA Schiphol, The Netherlands