

# **INSTRUCTION MANUAL**

## **FT-2F**

**YAESU MUSEN CO., LTD.**

TOKYO JAPAN

TABLE OF CONTENTS

GENERAL DESCRIPTION ..... Page 1

SPECIFICATIONS ..... Page 1

INSTALLATION ..... Page 2

- POWER REQUIREMENTS
- MOUNTING
- CONTROLS AND SWITCHES
- OPERATION

CIRCUIT DESCRIPTION ..... Page 7

- BLOCK DIAGRAM
- SEMICONDUCTOR COMPLEMENT
- THEORY OF OPERATION
- CRYSTAL CALCULATIONS

SERVICE INSTRUCTIONS ..... Page 12

COMPONENT LOCATION ..... Page 15

- ALIGNMENT INSTRUCTIONS
- RESISTANCE/VOLTAGE CHART

\*\*\*\*\*  
FT-2F VHF FM TRANSCEIVER  
\*\*\*\*\*

GENERAL DESCRIPTION

The model FT-2F VHF Transceiver is a precision built, compact, high performance FM transceiver designed to operate in the 2 meter FM amateur radio service. The FT-2F is completely transistorized and operates from a 12 volt DC system, however, it can be used with a 115 or 230 volt AC power supply together with its AC/DC adaptor. The FT-2F operates in the 144 to 148 MHz band on 12 crystal controlled channels, with selectable RF power output of 0.8 or 10 watts. The entire transceiver package is 6 5/8" wide, 2 1/2" high, 10" deep and weighs approximately 4 lbs. Heavy-gauge aluminium construction provides an extremely rugged package light in weight and virtually immune to the effect of vibration and shock.

SPECIFICATIONS

General

Frequency Range	:	144 - 148 MHz
Number of Channels	:	12 channels, 3 supplied
Modulation	:	Push-To-Talk
Power Drain	:	Receive 0.25 A Transmit 2.8 A (High) 0.8 A (Low)
Power Source	:	13.5 volts $\pm$ 15% (negative ground)
Dimensions	:	6 5/8" W x 2 1/2" H x 10" D
Weight	:	4 Lbs.
Standard Accessories Supplied	:	Dynamic microphone Dynamic speaker Connector plug DC cord fuse Mobile mount

### Transmitter

RF Output Power : 10 watts high, 0.8 watt low  
(selectable)  
Output Impedance : 50 ohms unbalanced  
Frequency Deviation : 15 KHz MAX  
Frequency Stability :  $\pm 0.001\%$  or less  
Spurious Radiation : -60 db  
Tone Burst : Nominal 2800 Hz

### Receiver

Circuit : Crystal controlled  
Double super heterodyne  
IF Frequency : 10.7 MHz & 455 KHz  
Sensitivity : 1 uV for 20 db quieting  
Selectivity :  $\pm 15$  KHz -6 db  
 $\pm 25$  KHz -50 db  
Audio Output : 2.5 watts

### INSTALLATION

The FT-2F FM Transceiver is a high quality VHF communication device which, with proper installation, will provide many years of dependable service. To prevent damage to the equipment during installation and use, care should be taken to observe the following precautions:

- ° Do not attempt to connect the power cord to a power source with the power switch ON.
- ° Do not connect the microphone with the power switch ON.
- ° Do not connect the antenna with the power switch ON.
- ° Do not connect the power cord to the primary power source until polarity and voltage are determined.

- ° Do not use a mis-matched antenna. Maximum efficiency will be obtained with an antenna system having a VSWR of less than 1.5:1.0. The antenna should be tuned to achieve a low VSWR.
- ° Do not key the transmitter unless an antenna or a dummy load is connected to the antenna coax connector.

### POWER REQUIREMENTS

The FT-2F is designed to operate nominally from a 12 volts DC power source. The transceiver requires 2.8 Amps on transmit and 0.25 Amp on receive. The fuse located in the power cord should be rated at 3 Amps. In fixed stations, the FP-2 AC power supply is used to provide 12 volts DC.

For mobile operation, the DC power is supplied by the vehicle battery and charging system.

The transceiver will operate over a voltage range of 10.5 to 14 volts DC. It is necessary to carefully adjust the charging system so that the upper limit of 14 volts is never exceeded.

UNDER NO CIRCUMSTANCES, SHOULD THE TRANSCEIVER BE OPERATED FROM A POWER SOURCE WHICH EXCEEDS 14 VOLTS. DAMAGE TO THE TRANSISTORS MAY OCCUR IF EXCESSIVE VOLTAGE IS APPLIED.

For vehicle installation, it is recommended that the power cord supplied should be used and run directly to the storage battery for both positive (red cable) and negative (black cable) terminals.

### MOUNTING

The FT-2F is supplied with a mounting bracket and DC power cord including a fuse holder.

The bracket should be fastened to the mounting surface with sheet metal screws. When the transceiver is mounted under the dashboard of a vehicle, keep the air path free from the vehicle's heater duct. Mount the transceiver away from the vehicle's heater system to prevent destruction of components.

Once the unit is in place in the bracket, tighten the knurled screws on the sides to secure the transceiver in the desired position. Connect the microphone, power cable and antenna cable to the transceiver.



In some applications, wattmeter indicating may be more convenient. The FT-2B transceiver may be operated in all modes without change in performance.

### CONTROLS AND SWITCHES

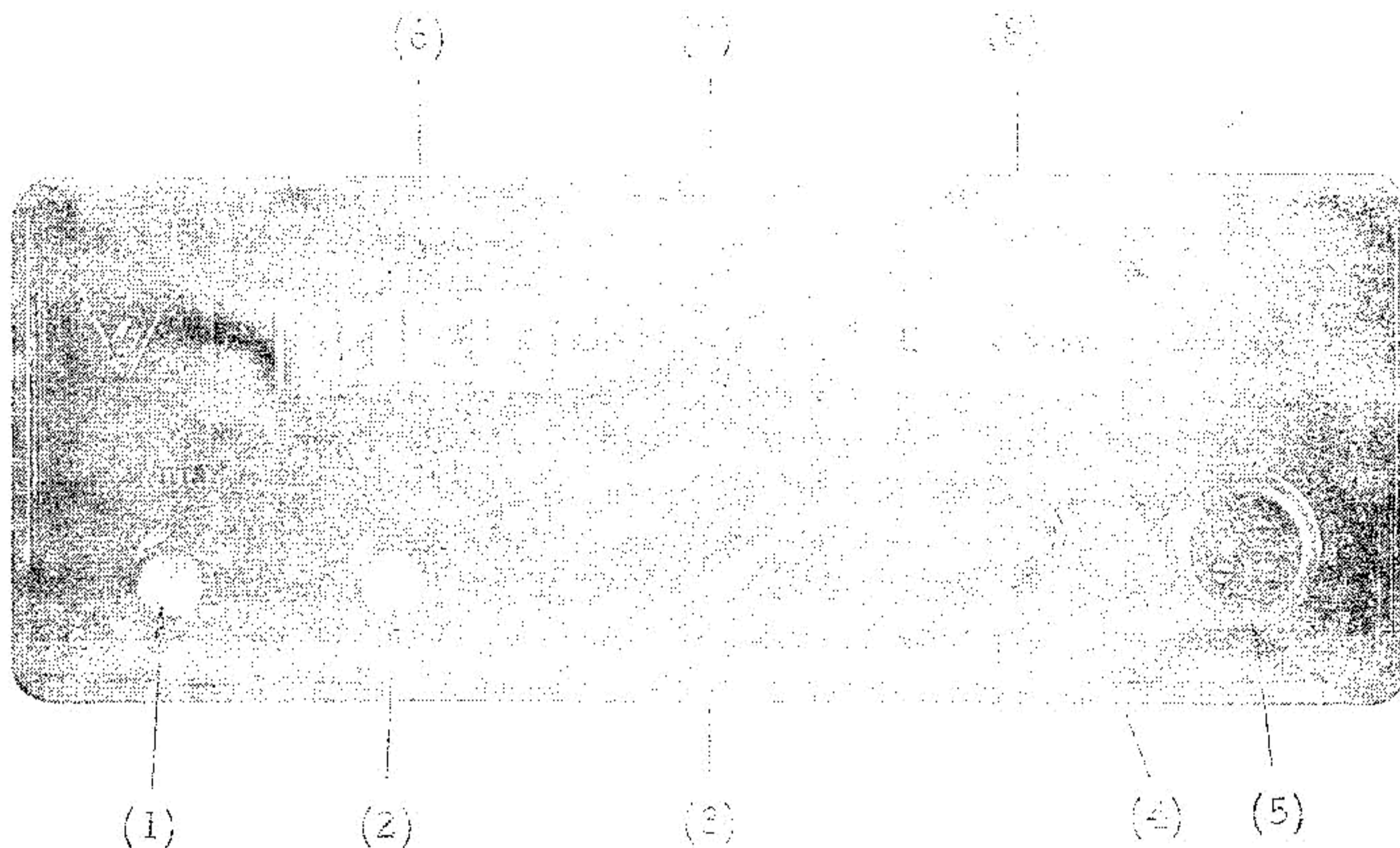

- (1) SQUELCH CONTROL - Squelch level field adjustment controls.
- (2) VOLUME CONTROL - Transceiver power ON and OFF and receiver audio amplifier gain.
- (3) CHANNEL SWITCH - Selects transceiver crystal controlled operating frequency.
- (4) HI/LOW SWITCH - In the HI position the transceiver output power is 10 watts and the meter indicates relative transmitter power output. In the LOW position, the transmitter power output is 0.5 watts and the meter indicates battery voltage.
- (5) MICROPHONE JACK - Four pin connector for microphone input and push to talk operation.
- (6) METER - A meter is provided to check transceiver performance. During operation in the receive mode, with the HI/LOW switch in the HI position, the meter indicates incoming signal strength.



In some applications, vertical mounting may be more convenient. The FT-2F transceiver may be mounted in any position without change in performance.

### CONTROLS AND SWITCHES

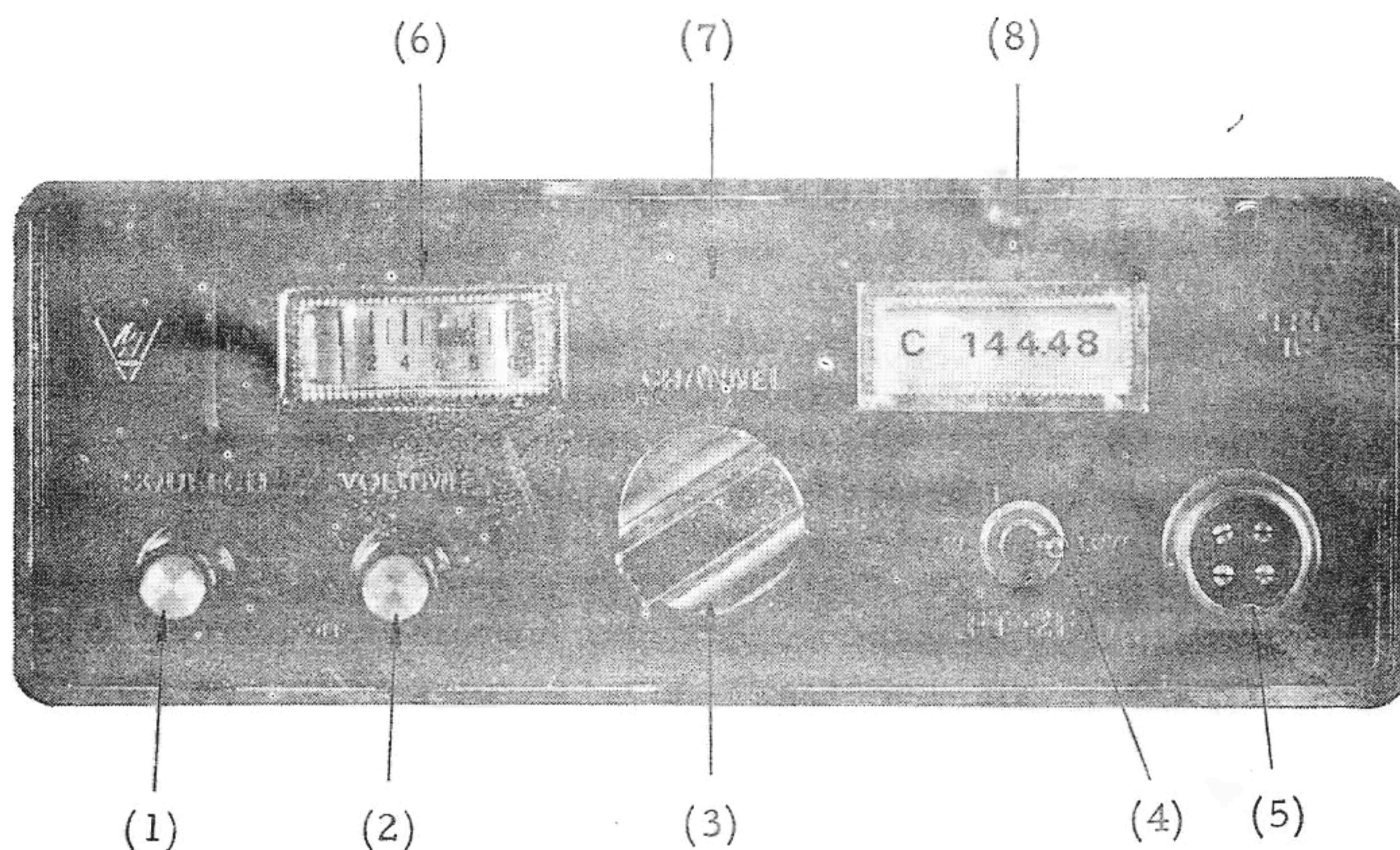

- (1) SQUELCH CONTROL - SQUELCH threshold adjustment controls.
- (2) VOLUME CONTROL - Transceiver power ON and OFF and receiver audio amplifier gain.
- (3) CHANNEL SWITCH - Selects transceiver crystal controlled operating frequency.
- (4) HI/LOW SWITCH - In the HI position the transceiver output power is 10 watts and the meter indicates relative transmitter power output. In the LOW position, the transmitter power output is 0.8 watts and the meter indicates battery voltage.
- (5) MICROPHONE JACK - Four pin connector for microphone input and push to talk operation.
- (6) METER - A meter is provided to check transceiver performance. During operation in the receive mode, with the HI/LOW switch in the HI position, the meter indicates incoming signal strength.



## AOS Switch

AOS (Automatic-Over-Signal) switch is located on the rear of chassis. In the ON position, a tone signal of approximately 2800 Hz is transmitted for a very short time at the end of the transmission. With the switch in the OFF position, this signal is disabled.

## Antenna

The FT-2F is designed for use with a 50 ohm resonant antenna. The antenna is the most critical part of the transceiver installation. Communication range is dependent on how well the antenna system is installed and adjusted. A commercial 1/4 wave antenna is readily available from most local sources.

The length of coax cable between the transceiver and the antenna is not critical but the VSWR of the antenna (including cable) is important. If the VSWR is greater than 1.5:1.0, the antenna must be adjusted for a low VSWR to obtain maximum performance of the transceiver.

## CIRCUIT DESCRIPTION

### BLOCK DIAGRAM

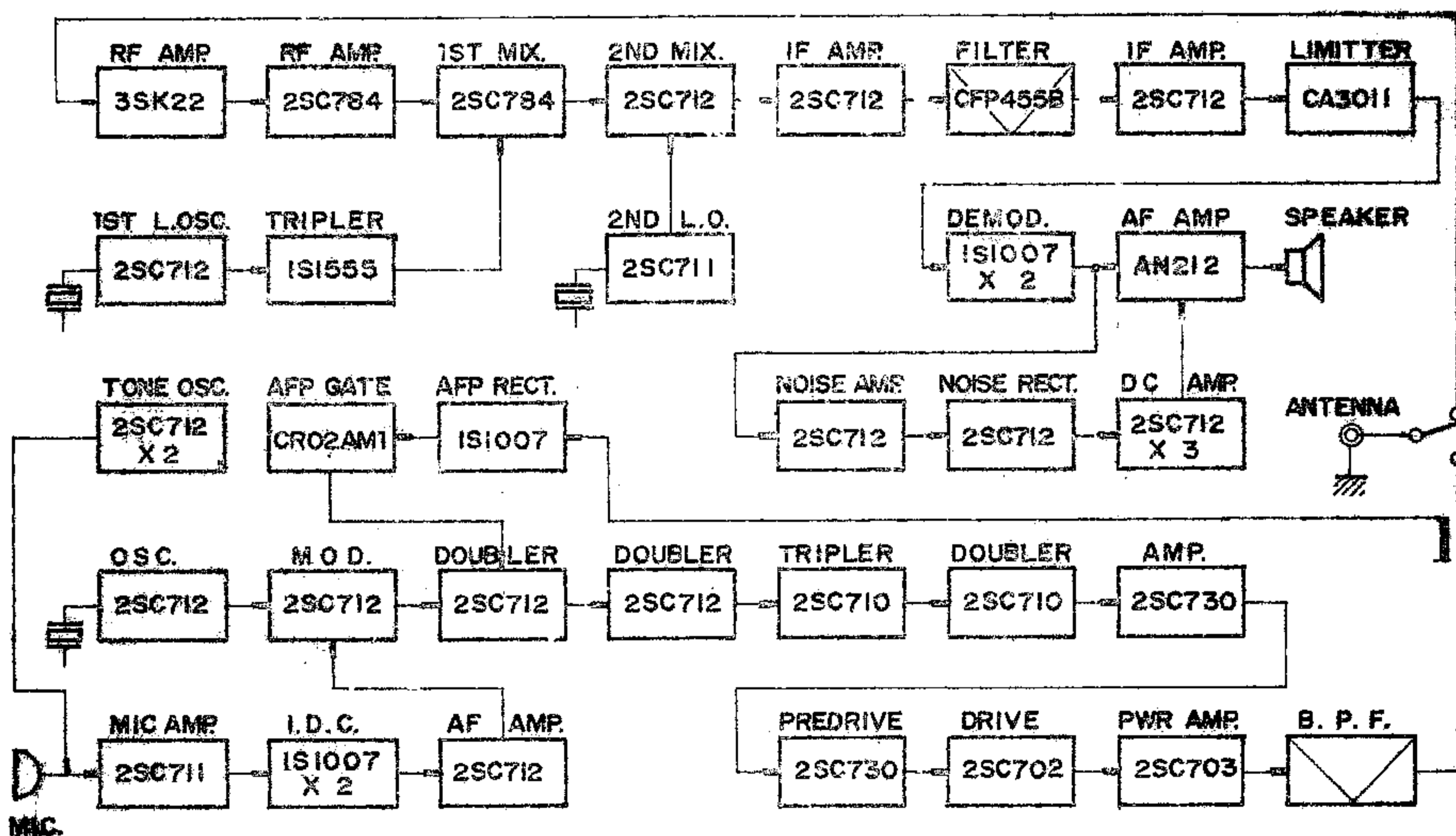



## SEMICONDUCTOR COMPLEMENT

### Transmitter

Q201	Crystal oscillator	2SC712D
Q202	Modulator	2SC712D
Q203	Doubler	2SC712D
Q204	Doubler	2SC712D
Q205	Tripler	2SC710D
Q206	Doubler	2SC710D
Q207	RF amplifier	2SC730
Q209	Mic amplifier	2SC711G
Q210	Mic amplifier	2SC712D
Q116	Tone burst generator	2SC712D
Q117	Tone burst generator	2SC712D
Q301	Predriver	2SC730
Q302	Driver	2SC702
Q303	Power amplifier	2SC703

### Receiver

Q101	1st RF amplifier	3SK22G
Q102	2nd RF amplifier	2SC784R
Q103	1st Mixer	2SC784R
Q104	1st Local oscillator	2SC712D
Q105	2nd Mixer	2SC712D
Q106	2nd Local oscillator	2SC711G
Q107	2nd IF amplifier	2SC712D
Q108	2nd IF amplifier	2SC712D
Q109	Limiter amplifier	CA3011
Q110	Audio amplifier	AN212
Q111	Noise amplifier	2SC712D
Q112	Noise rectifier	2SC712D
Q113	SQUELCH amplifier	2SC712D
Q114	SQUELCH amplifier	2SC712D
Q115	SQUELCH control	2SC712D

## THEORY OF OPERATION

### Transmitter

The transmitter is phase modulated and crystal controlled on 12 channels within the frequency range of 144-148 MHz.

The audio signal from the microphone is coupled to an audio amplifier stage Q209, 2SC711G. The audio output from the audio amplifier is coupled to the IDC (Instantaneous Deviation Control) circuit where both positive and negative peaks are clipped by diodes D203, and D204 (1S1007) when they exceed a predetermined clipping level. The IDC control VR-202 adjusts the audio level applied to the modulator and is used to set the maximum transmitter deviation to  $\pm 15$  KHz.

As oscillator stage Q201, 2SC712D oscillates at the fundamental crystal frequency which is multiplied 24 times in the succeeding stages to produce the desired transmitting frequency. A variable trimmer capacitor is connected in series with the crystals to adjust the transmitting frequency.

The oscillator output is coupled to the modulator stage Q202, 2SC712D.

The modulated output is then applied to the succeeding frequency multiplier stages to obtain the necessary frequency deviation at the transmitting frequency.

The frequency multipliers in the transmitter consist of three doublers Q203, 2SC712, Q204, 2SC712 and Q206, 2SC710, and a tripler Q205, 2SC710.

<u>Coils</u>	<u>Transistor</u>	<u>Frequency</u>	<u>Multipli- cation</u>
L201	Q202, 2SC712	6 MHz	x 1
L202, L203	Q203, 2SC712	12 MHz	x 2
L204, L205	Q204, 2SC712	24 MHz	x 2
L206, L207	Q205, 2SC710	72 MHz	x 3
L208, L209	Q206, 2SC710	144 MHz	x 2

The RF signal is amplified by the buffer stage amplifier Q207, 2SC730 and is then coupled into three class C amplifier stages which consists of predriver Q301, 2SC730, driver Q302, 2SC702, and final amplifier Q303, 2SC703. 10 watts of RF power is delivered into a 50 ohm load through the pi network and passband filter.

AFP (Automatic Final Protection) circuit is provided to protect the final transistor against over load conditions, which may occur if the transmitter is keyed without an antenna or with a high VSWR antenna system. When output current increase, diode D2 (1S1007) detects this current and supplies a control voltage to the D202 (CR02AM-2) which conducts. Thus the collector circuit of Q203, 2SC712D is grounded and RF energy is shunted to protect the following stages.

For low power operation, the power output is reduced to 0.8 watt by dropping the supply voltage to the final amplifier stages.

AOS (Automatic Over Signal) circuit provides an audio tone burst of approximately 2800 Hz at the end of each transmission to call attention to the end of a QSO.

A switch is provided on the rear panel to disable the tone burst signal, if desired.

### Receiver

The receiver is a double conversion super heterodyne which is designed for reception of FM signals on any of 12 fixed crystal controlled channels within the range of the 144-148 MHz band.

The signal received at the antenna is coupled to a first RF amplifier Q101, 3SK22 through T-R change over relay. Q101 is a MOS FET transistor which provides high rejection to cross modulation and intermodulation effects caused by strong input signals.

The output from the first RF amplifier is then coupled to a second RF amplifier Q102, 2SC784 and amplifies to the level which provides an optimum signal-to-noise ratio in the signal at the first mixer Q103, 2SC784.

The first mixer converts the RF signal into a 10.7 MHz intermediate frequency.

The output of the heterodyne oscillator Q104, 2SC712 is coupled to a tripler D103, 1S1555 and multiplied. The frequency relationship is as follows:

$$\text{Xtal Frequency MHz} = \frac{\text{Signal Frequency} + 10.7}{3} \text{ MHz}$$



The local oscillator injection signal is 10.7 MHz higher than the signal received.

The first IF (10.7 MHz) signal is fed to a second mixer Q105, 2SC712, with a resultant output signal at 455 KHz. A second heterodyne oscillator Q106, 2SC711 is crystal controlled and oscillates at 11.155 MHz to produce the 455 KHz second IF signal.

The 455 KHz second IF signal is fed to amplifier Q107, 2SC712. The signal amplified by Q107 is then fed to amplifier Q108, 2SC712 through a ceramic-mechanical filter CF-101. This filter determines the bandwidth and selectivity of the receiver.

The signal is then applied to limiter amplifier Q109, CA3011 integrated circuit. The limiter is designed so that input signal variations in amplitude produce no change in the amplitude of the output signal. The output from the limiter is applied to the discriminator where the FM signal is converted to the audio signal which is then fed to the audio amplifier Q110, AN212 integrated circuit. The amplifier delivers 2.5 watts maximum output to the speaker.

The receiver SQUELCH circuit consists of a noise amplifier, Q111, a rectifier, Q112, DC amplifiers Q113 and Q114, and a DC controller, Q115, 2SC712Ds. The noise produced at the output of the discriminator is amplified by Q111, and rectified DC voltage controls Q115 to conduct when noise is present. In the absence of an incoming RF carrier, this DC control cuts off the audio amplifier Q110, AN212 and thus speaker noise is eliminated. The SQUELCH threshold is adjusted by rotating the potentiometer on the front panel.

#### CRYSTAL CALCULATIONS

$$\text{Transmitter : Xtal Frequency MHz} = \frac{\text{Signal Frequency}}{24} \text{ MHz}$$

$$\text{Receiver : Xtal Frequency MHz} = \frac{\text{Signal Frequency} + 10.7}{3} \text{ MHz}$$

### Accessory Socket Connection

Pin 1	Ground
Pin 2	NC
Pin 3	Discriminator output
Pin 4	Ground
Pin 5	Ground
Pin 6	DC + 12V
Pin 7	DC + 12V
Pin 8	DC + 12V through power switch
Pin 9	PTT switch

For remote PTT operation, connect a switch between Pin 1 and Pin 9.

### SERVICE INSTRUCTIONS

The FT-2F transceiver has been aligned and calibrated at the factory with proper test instruments, and should not require realignment. Service or replacement of major components may necessitate subsequent realignment. Do not attempt alignment unless the operation of the transceiver is fully understood.

#### Test Equipment Required

A signal generator, vacuum tube volt meter, and a RF wattmeter.

#### Voltage and Resistance Measurements

Charts are provided listing voltage and resistance values from transistor pins to ground. Measurements are to be made with a VTVM.

## TRANSMITTER ALIGNMENT

Test points are provided in the chart below to facilitate alignment. Extreme care is required to avoid tuning of coils to the improper harmonic. When adjusting coils always tune to the peak that provides maximum output at the desired transmitting frequency.

TP 1	TP 2	TP 3	TP 4
0.6V DC	2V DC	2.5V DC	1.2V DC

Connect the RF wattmeter to the antenna terminal. Connect VTVM between TP 1 and ground and tune L201 for maximum reading. Connect VTVM to TP 2 and adjust L202 and L203 for maximum. L204 and L205 for TP 3. L206 and L207 for TP 4.

Adjust L208 and L209 for maximum RF output at desired frequency. Adjust TC213, TC201, TC303, TC305 and TC306 for maximum output at the desired frequency.

A frequency counter should be used to determine the transmitting frequency. If a counter is not available adjust the trimmer capacitor connected in series with the transmitting crystal for the best audio quality on another receiver operating at the same frequency.

## AUTOMATIC FINAL PROTECTION CIRCUIT ADJUSTMENTS

Disconnect grey shielded wire at X1 and measure the DC voltage between the center conductor and ground. Adjust VR3 for minimum VTVM reading.

Reconnect the grey shielded wire to X1. Disconnect the antenna and adjust VR201 until the power output meter indicates zero reading.

## RECEIVER ALIGNMENT

Connect VTVM to TP 1 and peak L109 for maximum VTVM reading, then detune L109 by rotating the tuning slug clockwise three turns.



Set the signal generator to the receiver frequency and connect to the antenna terminal. Adjust L101 through L108 and L110 through L113 for maximum reading on the S-meter.

Connect the VTVM to TP 3 and ground. Adjust L113 for zero reading. Connect the VTVM between the junction point of C159 and R146. Adjust L112 for maximum VTVM reading.

This completes the transceiver alignment.



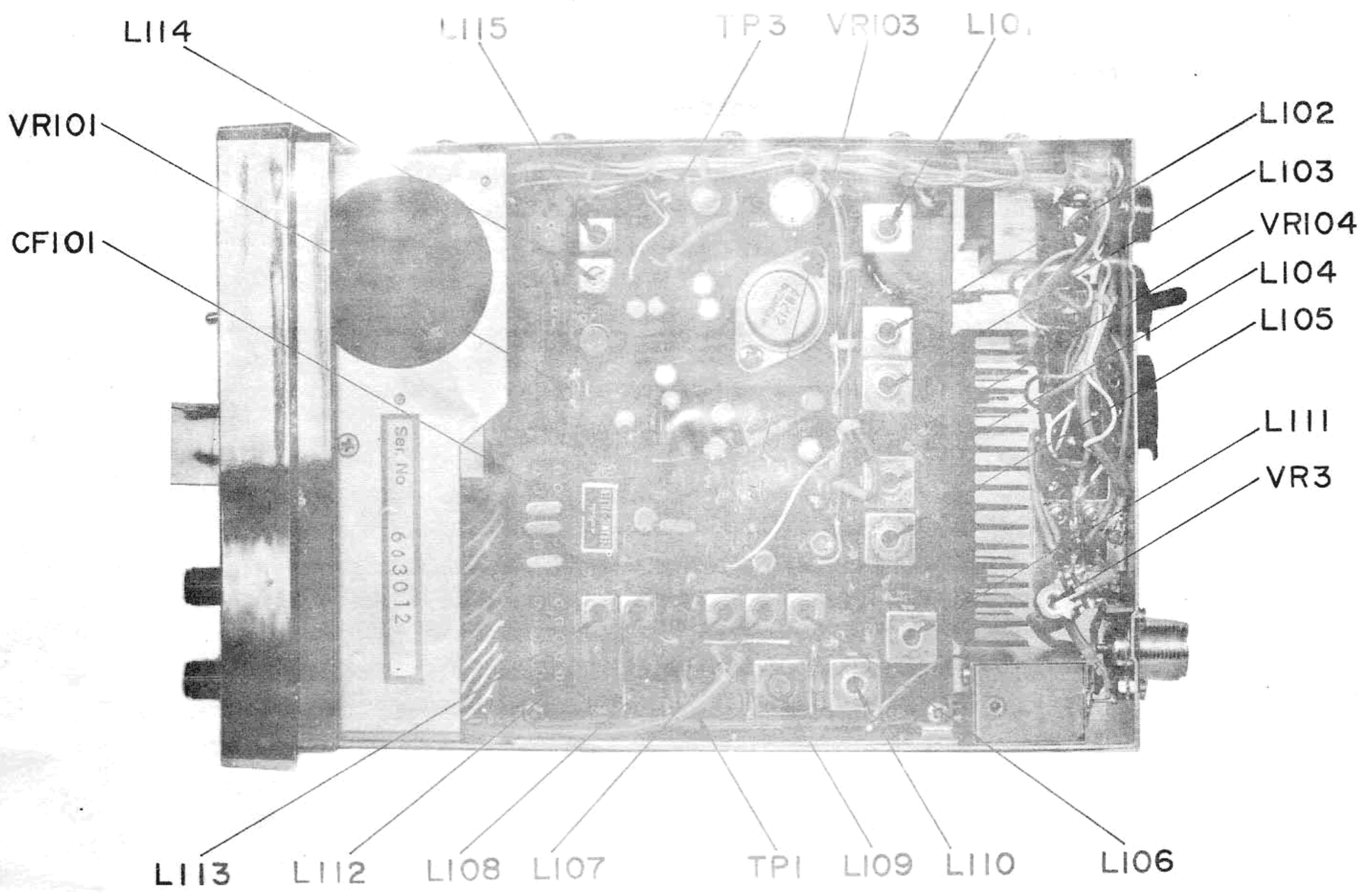

BOTTOM VIEW

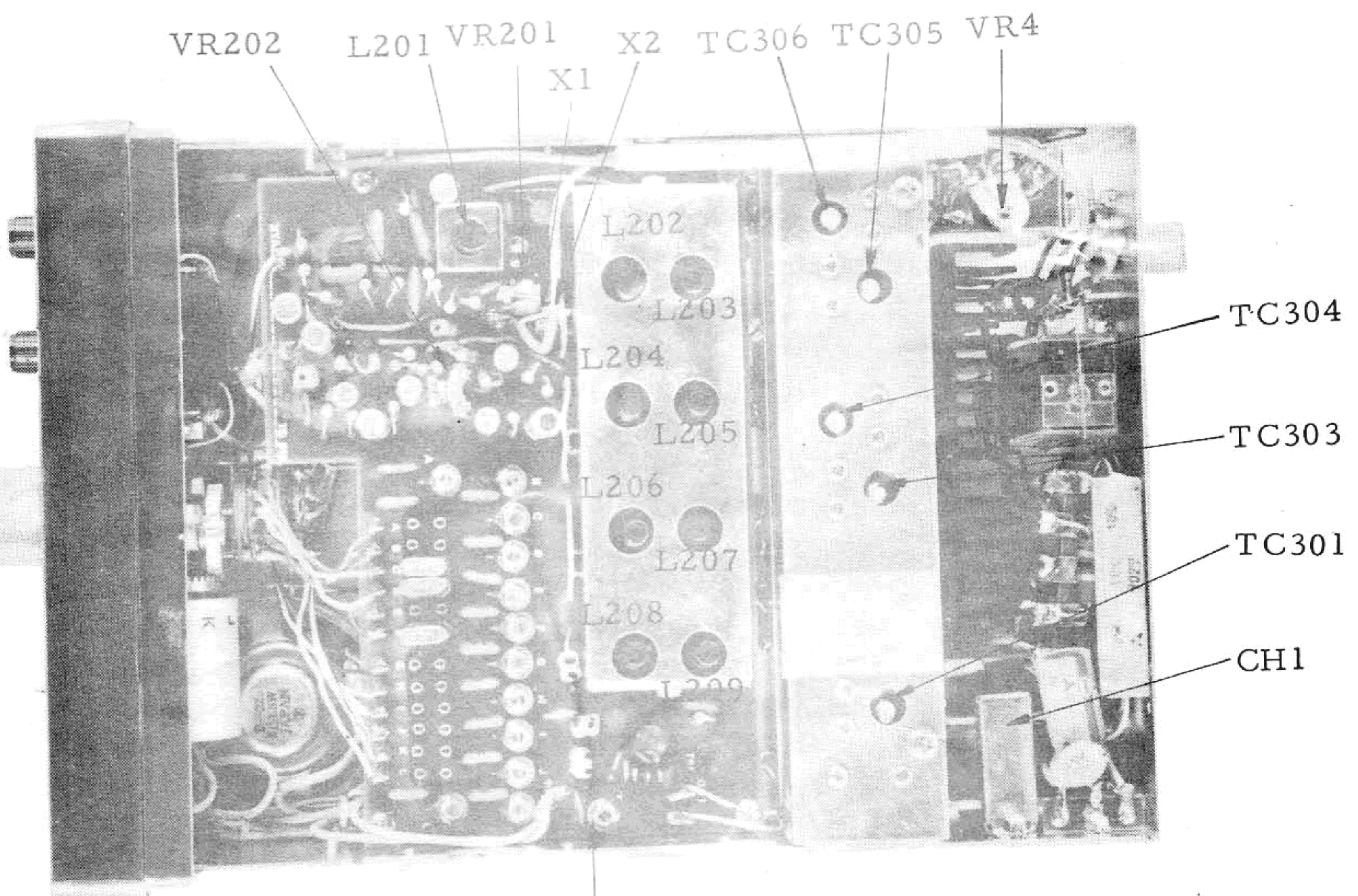

TOP VIEW



VOLTAGE CHART

No.	Emitter OR Source	Base OR Gate 1	Collector OR Drain	No.	Fmitter	Base	Collector
Q101	0.65	0	7.7	Q201	1.5	2.0	8.1
Q102	0.47	1.15	8.7	Q202	0.35	0.98	11.4
Q103	0.47	1.15	8.2	Q203	0.7	1.0	11.9
Q104	1.4	1.15	8.3	Q204	1.9	1.32	10.3
Q105	0.43	1.0	9.0	Q205	2.5	0.25	9.6
Q106	0.87	1.2	3.9	Q206	1.29	0.68	12.6
Q107	1.0	1.6	7.5	Q207	0	0.17	12.6
Q108	1.07	1.7	6.7	Q209	0.56	0.18	3.18
Q111	2.5	3.05	8.8	Q210	0.71	1.36	8.0
Q112	1.0	1.0	8.7				
Q113	0.09	0.75	0.2	Q301	0	0.27	12.6
Q114	0.09	0.08	5.5	Q302	0	0	12.6
Q115	0	0.7	0	Q303	0	0	12.6
Q116	6.0	6.3	8.5				
Q117	6.0	6.3	8.5				

No.	1	2	3	4	5	6	7	8	9	10	11	12	13	14
Q109	2.0	2.04	2.0	2.03	7.7	/	/	0	/	1.3	/	/	/	/
Q110	6.2	13.5	12.4	6.5	7.5	9.6	0.92	0	2.1	6.2	6.2	0	0	0

\* Voltage values are in volts D.C.



RESISTANCE CHART

No.	Emitter or Source	Base or Gate 1	Collector or Drain	No.	Emitter	Base	Collector
Q101	90	100K	220	Q201	1K	1.5K	2.5K
Q102	1K	4K	1.2K	Q202	480	1.1K	400
Q103	1K	4K	2.5K	Q203	480	1.1K	550
Q104	470	3.9K	480	Q204	180	950	300
Q105	1K	3K	650	Q205	180	900	300
Q106	470	3.3K	3K	Q206	56	800	100
Q107	1K	3.9K	1.8K	Q207	0	100	90
Q108	220	4.5K	800	Q209	330	1.2K	5.1K
Q111	450	7.6K	240	Q210	1K	1.7K	3.5K
Q112	4.7K	50K	240				
Q113	22	100K	2.2K	Q301	0	8	100
Q114	22	5.4K	2.2K	Q302	0	8	100
Q115	0	5.4K	7K	Q303	0	8	100
Q116	170K	27K	2.7K				
Q117	170K	27K	2.7K				

No.	1	2	3	4	5	6	7	8	9	10	11	12	13	14
Q109	6.5K	2K	1.2K	1K	1K	/	/	0	/	400	/	/	/	/
Q110	1.4K	260	600	1.9K	1.7K	1.8K	120K	0	3.3K	5K	3.7K	0	0	0

\* Resistance values are in ohms.  
 \* VOLUME control fully counter clockwise.  
 \* SQUELCH control fully counter clockwise.



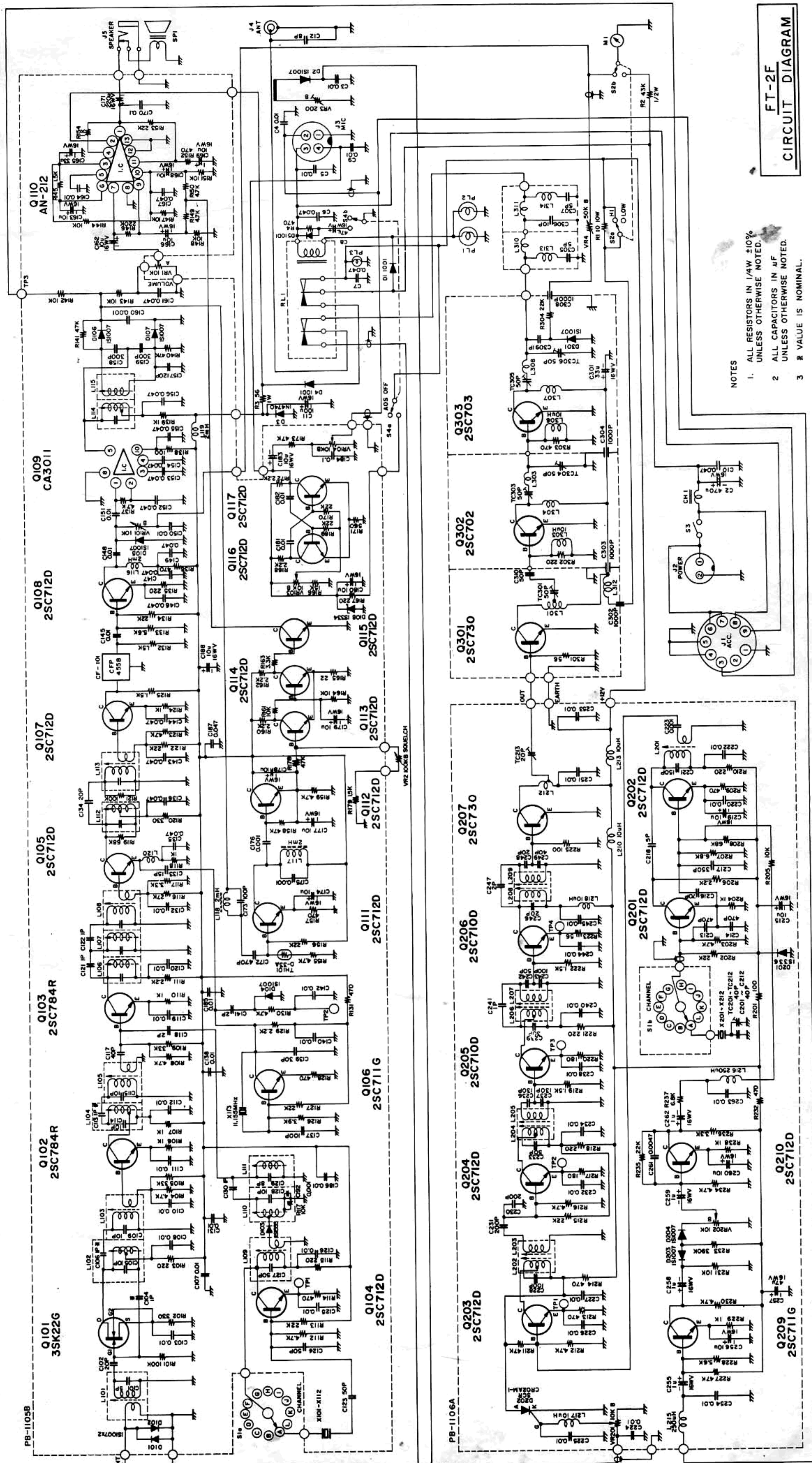

**FT-2F**  
**CIRCUIT DIAGRAM**

- NOTES
1. ALL RESISTORS IN 1/4W ±10% UNLESS OTHERWISE NOTED.
  2. ALL CAPACITORS IN µF UNLESS OTHERWISE NOTED.
  3. \* VALUE IS NOMINAL.



