

PUBLICATION NUMBER 1
ISSUE: 14.2.90

9008

AM/FM MODULATION METER

RACAL-DANA

RACAL-DANA INSTRUMENTS INC.

4 Goodyear Street, P.O. Box C-19541, Irvine, Ca 92713, USA.
Telephone: (714) 859-8999. TWX 910-595-1136. TLX 678-341

RACAL-DANA INSTRUMENTS LTD.

Hardley Industrial Estate, Hythe, Southampton, England SO4 6ZH
Telephone: Southampton (0703) 843265 Telex: 47600 Cables: Technico, Hythe, Southampton

RACAL-DANA INSTRUMENTS S.A.

18 Avenue Dutartre, 78150 Le Chesnay, France.
Telephone: (3) 955 88 88. TLX: 697 215

RACAL-DANA INSTRUMENTS GmbH.

Frankenforsterstrasse 21, 5060 Bergisch Gladbach 1, Federal Republic of Germany.
Telephone: 02204 60081. Telex: 8878428

RACAL-DANA INSTRUMENTS ITALIA (srl)

Via Mecenate 84/A, 20138 Milano M1, Italy.
Telephone: (02) 5062767/5052686/503444. TLX: 315697

RACAL

PUBLICATION DATE: DECEMBER 1975



ISSUE B

Modulation Meter 9008

(FROM SERIAL NUMBER 1751 ONWARDS)

'POZIDRIV' SCREWDRIVERS

Metric thread cross-head screws fitted to Racal equipment are of the 'Pozidriv' type. Phillips type and 'Pozidriv' type screwdrivers are not interchangeable, and the use of the wrong screwdriver will cause damage. POZIDRIV is a registered trade mark of G.K.N. Screws and Fasteners Limited. The 'Pozidriv' screwdrivers are manufactured by Stanley Tools Limited.

HANDBOOK AMENDMENTS

Amendments to this handbook (if any), which are on coloured paper for ease of identification, will be found at the rear of the book. The action called for by the amendments should be carried out by hand as soon as possible.

CONTENTS

		<u>Page No.</u>
SECTION 1	FRONTISPIECE TECHNICAL SPECIFICATION SUPPLEMENTARY DATA	Tech. Spec. (1) to (4) Tech. Spec. (5) and (6)
SECTION 2		
CHAPTER 1	GENERAL DESCRIPTION	
	INTRODUCTION	1-1
	FACILITIES AND DISPLAY	1-1
	INPUTS AND OUTPUTS	1-1
	POWER SUPPLY	1-2
	AC Supply	1-2
	Battery Option	1-2
	Battery Charging	1-2
	Reversed Polarity Protection	1-2
	PROGRAMMABILITY	1-2
	OPTIONS AND ACCESSORIES	1-3
	TEST EQUIPMENT	1-3
CHAPTER 2	OPERATING INSTRUCTIONS	
	AUTOMATIC OPERATION	2-1
	MAINS AND BATTERY POWER SELECTION	2-2
	DESCRIPTION OF CONTROLS AND INDICATORS	2-2
	Front Panel Items	2-2
	Rear Panel Items	2-4
	BATTERY CHECK SWITCH	2-5
CHAPTER 3	PRINCIPLES OF OPERATION	
	SUMMARY OF PRINCIPLES	3-1
	Introduction	3-1
	Sampling Mixer	3-1
	Measurement	3-1
	Oscillator Tuning	3-3
	FUNCTIONAL DETAILS	3-3
	Signal Input	3-3
	Sampling Mixer	3-3
	Oscillator Control Loop	3-4
	Out of Lock Indication	3-5
	Measuring Circuits	3-5

CHAPTER 3 (continued)

Page

Battery Check	3-6
SWITCHING SYSTEM	3-6
Introduction	3-6
Remote Control	3-6
Local Selection Switches	3-6

CHAPTER 4 TECHNICAL DESCRIPTION

INTRODUCTION	4-1
LOGIC CIRCUIT SYMBOLS	4-1
SAMPLING MIXER ASSEMBLY 19-0803	4-1
Pulse Generator	4-1
Sampling Mixer	4-2
AGC AMPLIFIER	4-2
Function	4-2
AGC Circuit Description	4-2
Signal Level Detection	4-3
Out of Range Level Detection	4-3
FREQUENCY-LOCKED LOOP AND OSCILLATOR CONTROL	4-4
Lock Input	4-4
Phase Shift Circuit	4-5
Selector Gate	4-5
Mixing Gate	4-5
Current Pumps and Integrator	4-6
Current Divider and Oscillator Tuning	4-6
Fast Lock Circuit	4-7
Out of Lock Signal	4-7
External Lock Indication	4-8
Mute Output	4-8
Threshold Detector	4-8
Oscillator and Divider	4-9
MEASURING CIRCUIT PCB 19-0804	4-9
Measuring Input	4-10
AM Detector	4-10
FM Limiter and Discriminator	4-10
+7V Stabilization	4-11
AM/FM Mode Switching	4-11
AF Filters	4-12
Attenuators (Meter Ranges)	4-12
Peak (+) Trough (-) and Level Outputs	4-13
Peak/Mean/Trough Switching	4-14
Local/Remote Selection	4-14

CHAPTER 4 (continued)

Page

Battery Check	4-15
POWER SUPPLY	4-15
AC (Mains) Operation	4-15
Power Supply (Stabilizer) PCB 19-0806	4-16
+10V Stabilization	4-16
Current Limiting	4-16
-10V Stabilization	4-16
Power Supply Low Voltage Inhibit	4-17
Battery Trickle Charging	4-17
Battery Full Rate Charging	4-18
Battery Powered Operation	4-18
Reversed Polarity Protection	4-18

CHAPTER 5

MAINTENANCE

POWER SUPPLY	
Supply Voltage Selection	5-1
Fuse Check	5-2
DC Fuses	5-2
Power Lead	5-2
REMOVAL OF COVERS	5-2
INITIAL FUNCTIONAL CHECK	5-3
BATTERY CHECK	5-4
REMOTE PROGRAM FACILITIES	5-4
Remote/Local Changeover	5-4
LIST OF TEST EQUIPMENT REQUIRED	5-5
POWER SUPPLY CHECKS	
AC (Mains) Input Circuit Resistance	5-6
Initial Power Supply Check Using DC Supply	5-6
AC (Mains) Charging and Operation	5-7
LOCK PCB CHECKS	5-9
Lock Circuit Alignment	5-9
Local Oscillator Alignment	5-10
Level Indicator Adjustment	5-10
Sampling Mixer Frequency Response	5-12
MEASURING PCB TESTS	5-13
Calibration	5-13
AF Output Levels	5-13
Automatic Level Control and AF Filter Check	5-15
Range Attenuator Check	5-16
AF Harmonic Distortion	5-17
AF Frequency Response	5-19
REMOTE CONTROL CHECK	5-20

CHAPTER 5 (continued)

	<u>Page</u>
BATTERY PACK FITTING INSTRUCTIONS	5-21
REMOVAL OF FRONT PANEL	5-23
REMOVAL OF REAR PANEL	5-23

LIST OF TABLES

<u>Table No.</u>		<u>Page</u>
1	Rear Panel 15-way Connector PL4	Tech. Spec. (5)
2	Peak, Trough and Mean Remote Selection Logic	Tech. Spec. (5)
3	Logic Levels (Except Pin 11)	Tech. Spec. (5)
4	Meter Range Program	Tech. Spec. (6)
5	Mains and Battery Power Selection	2-2
6	Mains Voltage Selection	5-1
7	List of Test Equipment Required	5-5
8	Sampling Mixer Response	5-12
9	AF Filter Check	5-16
10	Total Harmonic Distortion (AM)	5-18
11	Total Harmonic Distortion (FM)	5-18
12	AF Frequency Response	5-19

IN TEXT ILLUSTRATIONS

<u>Fig. No.</u>		<u>Page</u>
3.1	9008: Simplified Block Diagram	3-2
4.1	Level Detector Lock Indication	4-4
4.2	Simplified Circuit: Current Divider	4-6
4.3	AM Detector Equivalent Circuit	4-10
5.1	9008 Chassis Layout: Topside	5-25
5.2	9008 Chassis Layout: Underside	5-27

SECTION 3 PARTS LISTS COMPONENTS LAYOUTS AND CIRCUIT DIAGRAMS

Circuit and Layout: Sampler PCB	Fig. 1
Parts List 1: Sampler PCB 19-0803	
Parts List 2: Measuring Circuit PCB 19-0804	
Component Layout: Measuring Circuit PCB	Fig. 2
Circuit: Measuring Circuit PCB	Fig. 3
Parts List 3: Lock Circuit PCB 19-0805	
Component Layout: Lock Circuit PCB	Fig. 4
Circuit: Lock Circuit PCB (Part 1, AGC)	Fig. 5
Circuit: Lock Circuit PCB (Part 2)	Fig. 6
Parts List 4: Power Supply PCB 19-0806	
Component Layout: Power Supply PCB	Fig. 7
Circuit: Power Supply PCB	Fig. 8
Parts List 5: Main Chassis, Front and Rear Panels	
Overall Block Diagram: 9008	Fig. 9
Parts List 6: Battery Unit Chassis Assembly	
Circuit: Battery Pack (Option)	Fig. 10

SECTION 1

TECHNICAL SPECIFICATION

TECHNICAL SPECIFICATION

NOTE: Users of instruments with serial numbers 1701 to 1750 should note the supplementary information which is inserted in a few places in the text.

INPUT CHARACTERISTICS

Carrier frequency range:	1.5 MHz to 2 GHz.
Input level:	<u>Low input:</u> 5 to 100 mV r.m.s. up to 500 MHz. 10 to 150 mV r.m.s. from 500 MHz to 1 GHz. 20 to 150 mV r.m.s. from 1 GHz to 2 GHz. <u>High input:</u> 50 mV to 1V r.m.s. up to 500 MHz. 150 mV to 1V r.m.s. from 500 MHz to 2 GHz.
Level setting:	Fully automatic.
Input impedance:	50Ω nominal.

FM MEASUREMENT

Deviation ranges:	1.5, 3, 5, 10, 15, 30, 50 and 100 kHz peak deviation f.s.d. Measurements of positive, negative and mean deviation can be made.
Modulation frequency range:	50 Hz to 30 kHz.
Accuracy:	± 2% of f.s.d. ± 1% of reading at 1 kHz.
Frequency response:	(1) ±0.2 dB with respect to 1 kHz from 300 Hz to 3 kHz. (2) ±0.5 dB with respect to 1 kHz from 50 Hz to 30 kHz.
Residual f.m. noise	-52 dB with respect to 10 kHz peak deviation measured on the AF output, with the 3 kHz filter in, at carrier frequencies up to 250 MHz then increasing at 6 dB per octave above this frequency.

AM rejection: Additional deviation error is less than 250 Hz with an a.m. depth of up to 80% and a modulating frequency in the range 300 Hz to 3 kHz.

AM MEASUREMENT

Modulation depth ranges: 5, 10, 15, 30, 50 and 100% f.s.d. modulation depth. Measurements of peak, trough or mean amplitude relative to carrier may be measured.

Modulation frequency: 50 Hz to 30 kHz.

Accuracy: $\pm 2\%$ of f.s.d. $\pm 1\%$ of reading at 1 kHz.

Frequency response: (1) ± 0.2 dB with respect to 1 kHz from 300 Hz to 3 kHz.
(2) ± 0.5 dB with respect to 1 kHz from 50 Hz to 30 kHz.

Residual a.m.: Less than 1% for inputs greater than 10 mV r.m.s.

IF OUTPUT

Frequency: 430 kHz nominal.

Level: 100 mV r.m.s. e.m.f. ± 2 dB.

Output impedance: 600 Ω nominal.

AF OUTPUT

Response: (1) Normal: ± 0.5 dB over the frequency range 50 Hz to 30 kHz,

(2) Filter in: 300 Hz to 3 kHz at 3 dB points.

Level: 1V r.m.s. e.m.f. ± 2 dB (meter f.s.d. 10 scale).
200mV r.m.s. in Serial Numbers 1751-2000.

Output impedance: 600 Ω nominal.

Harmonic distortion: FM: Less than 0.5% for f.m. deviations up to 100 kHz.
AM: Less than 1%, typically 0.5% for a.m. depths up to 80%.

DC OUTPUT

Level: 1V e.m.f. ± 0.5 dB at meter f.s.d. (10 scale).
Output impedance: 10 k Ω nominal.

REMOTE CONTROL

Functions selectable: AM or FM
Meter range
Filter In/Out
Peak, Trough and Mean (AM)
Positive, negative or mean peak deviation (FM).

Control signals: Parallel input
(1) Logic '0', 0V to +0.5V or open circuit.
(2) Logic '1', +3V to +7V. (+3V to +30V in
1701 - 1750)

Input impedance: 3.3 k Ω minimum.

Other inputs: Positive and negative d.c. power supply inputs
(12V to 20V).

Outputs: (1) d.c. output 1V e.m.f. ± 0.5 dB at meter
f.s.d.
(2) Lock signal.

POWER REQUIREMENTS

AC mains operation: Voltage 94V to 130V
188V to 260V
Frequency 45 to 440 Hz
Consumption approximately 15VA.

External d.c. supply: 12V to 20V positive and negative (which must be
fitted with 500 mA fuses at source).

Optional battery pack: Rechargeable nickel-cadmium cells.

ENVIRONMENTAL & SAFETY SPECIFICATIONS

Operating temperature:	0°C to +55°C (0°C to +40°C with battery pack).
Storage temperature:	-40°C to +70°C (-40°C to +50°C with battery pack).
Mechanical:	In accordance with IEC 68 and British Joint Services Specification REMC/20FR/CAT III.
Safety:	Designed to meet IEC 348 (BS 4743).

MECHANICAL

Physical:	<u>Height</u>	<u>Width</u>	<u>Depth</u>
	96.5 mm	240 mm	268 mm

Weight: approximately 3.2 kg (5.2 kg with battery pack).

OPTIONS AND ACCESSORIES

Battery pack kit BU1: (Part No 11-1148)	Rechargeable Nickel-Cadmium cells give a minimum 6 hours continuous operation. The charger in the 9008 enables cells to be trickle charged during normal mains operation. A discharged battery can be fully charged in approximately 14 hours by setting the power switch to OFF/CHARGE.
Carrying case: (Part No: 15-0450 standard unit or 15-0435 for battery powered unit)	A robust carrying case is offered as an option, which will enable the instrument to be carried by a shoulder strap.
Coupling unit:	An RF Coupling Unit (Part No. 11-0167) enables measurements to be made on high power transmitter signals without direct connection.
Antenna:	A telescopic antenna is available for use in suitable conditions.
Reverse Power Protection Fuse:	Part No. 11-1565. Provides protection for the 9008 in the event of accidental application of damaging levels of RF signal from the equipment under test.

SUPPLEMENTARY DATA

REAR PANEL 15-WAY CONNECTOR

The rear panel connector (PL4) provides connection facilities for a remote control system and for the optional battery pack.

TABLE 1

Rear Panel 15-Way Connector PL4

(See Notes on following page)

Pin	Facility	Program Control Logic	
		'0'	'1'
1	AM/FM Select	FM	AM
2	Filter Select	Filter OUT	Filter IN
3	Peak (+) Select) See Table 2 below	Not Selected	Selected
4	Trough (-) Select)		
5	6 dB Select)		
6	10 dB Select) Range selection	Not Selected	Selected
7	20 dB Select) (see NOTE 6)	Not Selected	Selected
8	DC (analogue) output (NOTE 1)		
9	'In Lock' indication (NOTE 2)		
10	Battery Check input (NOTE 3)		
11	See NOTE 4		
12	+ve Battery in/charge (NOTE 5)		
13	Common earth (0V)		
14	-ve Battery in/charge		
15	Mute for 'Battery Check' (NOTE 5)		

TABLE 2

Peak, Trough and Mean Remote Selection Logic

PL4 Pin 3 (PEAK)	PL4 Pin 4 (TROUGH)	Function
0	0	No function
1	0	PEAK
0	1	TROUGH
1	1	MEAN

TABLE 3

Logic Levels

(except Pin 11)

'0'	'1'
Open Circuit or less than +0.5V	Between* +3V and +7V

* For serial numbers 1701 to 1750 logic '1' maximum is +30V

NOTES ON TABLE 1

1. DC (Analogue) Output (pin 8). This output is identical to that at the BNC DC output socket on the rear panel.
2. In Lock Indication. This output is a steady logic level. Logic '1' signal for "in lock", a '0' signal for "out of lock". The output is TTL but can drive only a single load.
3. Pin 10 Battery Check Input. This pin feeds the battery voltage to the front panel meter when the appropriate monitor switch on the battery pack is pressed.
4. (a) Serial Numbers 1751 onwards: pin 11 is not used.
(b) Serial Numbers 1701 to 1750: a voltage of not less than +10V applied to pin 11 will select remote program control. Refer to Chapter 5 para. 5.10.
5. Pin 15. This line isolates the meter from modulation information whilst in use on battery check.
6. Meter Range Selection. The eight measurement ranges are obtained by programming pins 5, 6 and 7 in accordance with Table 4.

TABLE 4
Meter Range Program

Program	Meter Scale	Program	Meter Scale
0 dB	= 1.5	20 dB	= 15
6 dB	= 3	20+6 dB	= 30
10 dB	= 5	20+10 dB	= 50
10+6 dB	= 10	20+10+6 dB	= 100

SECTION 2

DESCRIPTION

OPERATION & MAINTENANCE

CHAPTER 1

GENERAL DESCRIPTION

INTRODUCTION

1.1 The Racal Modulation Meter 9008 provides a simple and unambiguous method of measuring the modulation depth of a.m. signals and the peak deviation of f.m. signals. A feature of the instrument is the entirely automatic tuning and level setting, which operates over the entire range of 1.5 MHz to 2 GHz, and is available by either local control or remote programming.

FACILITIES AND DISPLAY

1.2 Measurements of peak deviation in eight ranges and modulation depth in six ranges are clearly displayed on a meter. A divide-by-two Meter Range switch enables readings always to be taken in the upper half of the meter scale where measurement is more accurate. A switched AF Filter is provided for use in conditions of high signal noise. An Out of Lock indicator flashes if the input signal is outside the specified amplitude or frequency limits.

1.3 AM or FM operation is selected by a three-position Function switch which includes a position for level indication. When LEVEL is selected, the panel meter indicates the approximate input signal amplitude. This is particularly useful if the lock lamp flashes due to incorrect signal amplitude, as it enables the user to determine immediately whether the signal is above or below the level required and to take the necessary corrective action. The facility is also useful when tuning a transmitter under test.

1.4 Another three-position switch permits measurement of peak and trough amplitudes on AM and positive and negative deviation on FM. In the third position the mean of the modulation depth or the mean of the peak frequency deviation can be measured. A description of controls and indicators commences at page 2-2.

INPUTS AND OUTPUTS

1.5 Two signal input sockets are provided on the front panel, each terminated in 50Ω . The 'low' input is for signal levels between 5 mV and 150 mV r.m.s. The 'high' input is for signals between 50 mV and 1V r.m.s. The sensitivities at different portions of the frequency spectrum are given on page 2-1.

1.6 On the rear panel, the i.f., the demodulated a.f. and a d.c. (analogue) output equivalent to the meter reading, are available at BNC sockets. These can be monitored by oscilloscope or other measuring equipment. The a.f. output is notable for a very low level of harmonic distortion, less than 1% for deviations up to 100 kHz and a.m. depths up to 80%, thus permitting realistic measurement of modulation distortion by means of a suitable Wave Analyser.

- 1.7 Other rear panel connectors are the a.c. mains plug and a multiway socket for remote program and external battery connections.

POWER SUPPLY

AC Supply

- 1.8 The instrument operates from nominal 110V or 220V a.c. supplies, 45 to 440 Hz. Mains voltage selection is by means of two rear panel switches which provide four possible voltage selections.

Battery Option

- 1.9 An optional battery pack containing rechargeable nickel-cadmium cells can be attached to the underside cover of the instrument and connected via the multiway rear panel connector. A rear panel switch selects battery or mains operation, as required. The battery pack has a battery check facility.

Battery Charging

- 1.10 With the battery pack fitted, and the instrument connected to the mains supply, the internal power circuit will function as a battery charger which provides a trickle charge when operating as a mains powered instrument and a full charge facility when the POWER switch is set to OFF/CHARGE. Refer to Table 5 on page 2-2 for a summary of the mains and battery power switching. A fully charged battery will give 6 hours operation. To fully charge a discharged battery requires 14 hours. Avoid overcharging, as it will progressively reduce battery charge capacity.

Reversed Polarity Protection

- 1.11 If the batteries are inadvertently connected with reversed polarity, the 500 mA fuses in the battery pack will rupture. A customer fitting an external d.c. supply must fit a 500 mA fuse in each +10V and -10V line to ensure reversed polarity protection.

PROGRAMMABILITY

- 1.12 Local or remote control can be selected by the front panel LOCAL/REMOTE switch*. The 15-way socket fitted to the rear panel gives access to the logic circuits controlling the selection of the following functions.

- Local/Remote Control
- AM or FM Mode
- AF Filter in/out
- Meter Range
- Peak, Trough and Mean (AM)
- Positive, Negative or Mean peak deviation (FM)

* The LOCAL/REMOTE switch is not fitted to serial numbers 1701 to 1750.

Details of logic levels will be found in the supplement to the Technical Specification.

OPTIONS AND ACCESSORIES

Options

- 1.13 (a) Battery Pack Refer to paragraphs 1.9 and 1.10.
- (b) Carrying Case robust case with shoulder strap.

Accessories Available to Order

- 1.14 (a) RF Coupling Unit The Coupling Unit (Part No. 11-01167) enables measurement to be made on high powered transmitters without direct connection and with adjustable coupling.
- (b) Telescopic Antenna This wideband antenna can be plugged into the appropriate input socket. It is suitable for use only where there is no risk of receiving false or interfering signals which could lead to misleading readings.

TEST EQUIPMENT

1.15 The list of recommended test equipment on page 5-5 is adequate for service-ability tests on the instrument. The user must, however, bear in mind any limitations of the test equipment available to him and should not attempt calibration tests unless the signal source has a specification better than the 9008 in terms of modulation accuracy and low distortion. A calibration service and advice on test equipment are available from Racal Instruments Ltd.

CHAPTER 2

OPERATING INSTRUCTIONS

- NOTES
1. The instrument should have been prepared for use as described in Chapter 5. If the optional battery power supply is fitted, reference should be made to Table 5 on page 2-2 for correct operation of power supply switches.
 2. A description of controls and indicators commences at page 2-2.

AUTOMATIC OPERATION

- 2.1
- (1) Set the controls as follows:-
 - (i) POWER switch to ON.
 - (ii) FUNCTION switch to AM or FM, according to the signal to be checked.
 - (iii) AF FILTER to OUT.
 - (iv) PEAK/MEAN/TROUGH switch, as required.
 - (v) The two-position Meter Range switch to the 3-100 position.
 - (vi) The horizontal METER RANGE switch to the 100/50 position.
 - (2) Connect the signal to be checked to the appropriate INPUT socket. If the amplitude is not known use the 1V r.m.s. socket initially.
 - (3) The IN LOCK lamp should show a steady illumination, if it continues to flash the cause is likely to be one of the following:-
 - (a) Signal frequency outside the specified operating range (1.5 MHz to 2 GHz).
 - (b) Modulation in excess of the specified ranges (AM or FM).
 - (c) Signal level too high or too low. (Use the LEVEL position of the Function switch to check the input level. See para. 5.6). Check that the appropriate Input socket is connected. The input characteristics over the frequency range are as follows:-

Low Input Socket

5 to 100 mV r.m.s. up to 500 MHz
10 to 150 mV r.m.s. from 500 MHz to 1 GHz
20 to 150 mV r.m.s. from 1 GHz to 2 GHz

High Input Socket

50 mV to 1V r.m.s. up to 500 MHz
150 mV to 1V r.m.s. from 500 MHz to 2 GHz

- (4) A meter reading may be taken as soon as the IN LOCK lamp gives a steady illumination. Set the METER RANGE switches to give the most convenient indication on the meter scale. Under noisy signal conditions the AF FILTER may be switched to IN.

- (5) Read the measurement from the appropriate scale on the meter, according to the settings of the METER RANGE switches.

TABLE 5
Mains and Battery Power Selection

		Mains Plug and Battery Connection State and Operational Condition			
POWER ON/OFF Switch Position	BATTERY-MAINS Switch Position	Mains 'In' Battery 'In'	Mains 'out' Battery 'In'	Mains 'In' Battery 'out'	Mains 'out' Battery 'out'
ON	MAINS	Operates from mains: battery trickle charged.	No operation	Operates from mains.	No operation.
OFF-CHARGE	MAINS	No operation. Batteries on full charge.	No operation	No operation	No operation
ON	BATTERY	Operates from batteries.	Operates from batteries.	No operation.	No operation.
OFF-CHARGE	BATTERY	No operation. Batteries on full charge.	No operation	No operation	No operation

DESCRIPTION OF CONTROLS AND INDICATORS

Front Panel Items

2.2

POWER ON/OFF CHARGE switch

The switch function depends on the setting of the rear panel BATTERY/MAINS switch, as follows:-

'AC Only' Instrument

With MAINS selected the POWER switch provides on/off switching of the rectified a.c. supply in the internal power unit.

AC and Battery Instrument

Table 5 on page 2-2 summarizes the relationship between the POWER switch, the BATTERY/MAINS switch and the alternative mains or battery power sources.

AM/LEVEL/FM
switch

This switch connects the measurement circuits to the appropriate AM or FM signal path. The LEVEL position gives an approximate logarithmic meter reading of the input signal level.

METER RANGE
(horizontal switch)

Selects the appropriate peak deviation or modulation depth range to provide suitable meter deflections. The range markings are colour coded to match the corresponding scales on the meter.

METER RANGE
(two-position switch)

This switch, in conjunction with the other Meter Range switch, effectively doubles the length of the meter scale. It allows all readings, except those of the lowest range, to be displayed in the upper half of the scale.

AF FILTER
switch

When switched to the IN position it restricts the AF bandwidth to 300 Hz to 3 kHz at the 3 dB points.

LOCAL/REMOTE switch
(From serial number 1751)

This switch selects local control, or remote programming via the rear panel connector.

PEAK/MEAN/TROUGH
switch

This switch selects the Peak detector or the Trough detector, thus enabling measurements to be made on either peak or trough of an a.m. signal, or positive or negative peak deviations of an f.m. signal. In the MEAN position the peak and trough measurements are averaged to the formula:-

$$\frac{\text{Peak Reading} + \text{Trough Reading}}{2}$$

IN LOCK Indicator lamp

With POWER switch to ON this lamp will flash until the instrument has locked to the input signal, when it will display a steady illumination.

MAINS ON Indicator lamp

This lamp illuminates in both positions of the POWER switch whilst a.c. power is connected.

Input sockets (BNC)

Input (high): 1V max, 50 Ω impedance

Input (low): 150 mV max, 50 Ω impedance

NOTE: The absolute maximum input level is 3V r.m.s. on both inputs.

The symbol  on the front panel advises the user to consult the handbook for precise input level details.

Rear Panel Items

2.3 Rear Panel Connections

IF Output (BNC)

430 kHz nominal output.
100 mV r.m.s. e.m.f. nominal.
Output impedance 600 Ω .

AF Output (BNC)

Output level 1V r.m.s. e.m.f. (nominal) at f.s.d. (10 scale). Output impedance 600 Ω . (200mV r.m.s. in Serial Number 1751-2000).

DC Output (BNC)

Provides analogue output proportional to meter reading.
Output level 1V e.m.f. (nominal) at f.s.d. (10 scale).
Output impedance 10k Ω nominal.

Multiway Connector

Provides for remote program connections and an input point for an external battery supply. Connection details are in Table 1 on page Tech. Spec. (5).

2.4 Rear Panel Controls

Mains (AC) Input Plug

A fixed 3-pin plug. A three core supply cable is supplied with the instrument for the mains connection.

Voltage Selector Switches

Two slide switches permit four possible voltage selections as follows:-

94 to 110V	188 to 220V
110 to 130V	220 to 260V

Refer to para. 5.1.

BATTERY/MAINS Switch

This switch will be operated in the MAINS position except when 'Battery' operation is required. Table 5 on page 2-2 summarizes the operational combinations of the POWER and BATTERY/MAINS switches together with the alternative power connections, assuming that batteries are fitted.

BATTERY CHECK SWITCH

2.5

The optional battery pack is fitted with a non-locking toggle switch by which the battery voltage can be monitored using the battery check markings on the meter scale. A reading to the right of the line marked thus
→|← is satisfactory.

NOTE: In serial numbers 1701-1750 the meter scale has a green portion which denotes a satisfactory battery check.

CHAPTER 3

PRINCIPLES OF OPERATION

NOTE: In reading this chapter reference should be made to the explanatory block diagram Fig. 3.1 located on the following page. The overall block diagram Fig. 9 (at the back of the book) gives greater detail, relating circuit functions to the separate p.c.b. Assemblies, as well as showing interconnections.

SUMMARY OF PRINCIPLES

Introduction

3.1 The Modulation Meter 9008 dispenses with the tedious tuning and level setting procedures of conventional modulation meters by exploiting the principle of the sampling mixer combined with a frequency - locked loop controlling a local oscillator.

Sampling Mixer

3.2 The external input signal and a pulse generator signal derived from a local oscillator, are applied to separate inputs of the sampling mixer. The oscillator automatically tunes to a point at which a nominal 430kHz difference frequency (the i.f.) is obtained at the sampling mixer output.

3.3 The output from the sampling mixer (the i.f.) is fed to the Lock Assembly and there offered two distinct paths:-

- (a) Via an automatic gain control (a.g.c.) stage to the a.m. and f.m. detectors of the measurement circuit on another p.c.b.
- (b) Via a low-pass filter and limiter stage to the oscillator control loop.

Measurement

3.4 The a.g.c. stage in the measurement path ensures that a constant mean i.f. signal level is applied to the a.m. detector. By virtue of this constant input level a reading of percentage modulation depth can be obtained by measuring the absolute value of the detected audio signal and applying this measurement to the meter. A 'peak-mean-trough' switch permits measurement of both positive and negative-peaks of the modulating waveform, or the mean value of the modulated signal.

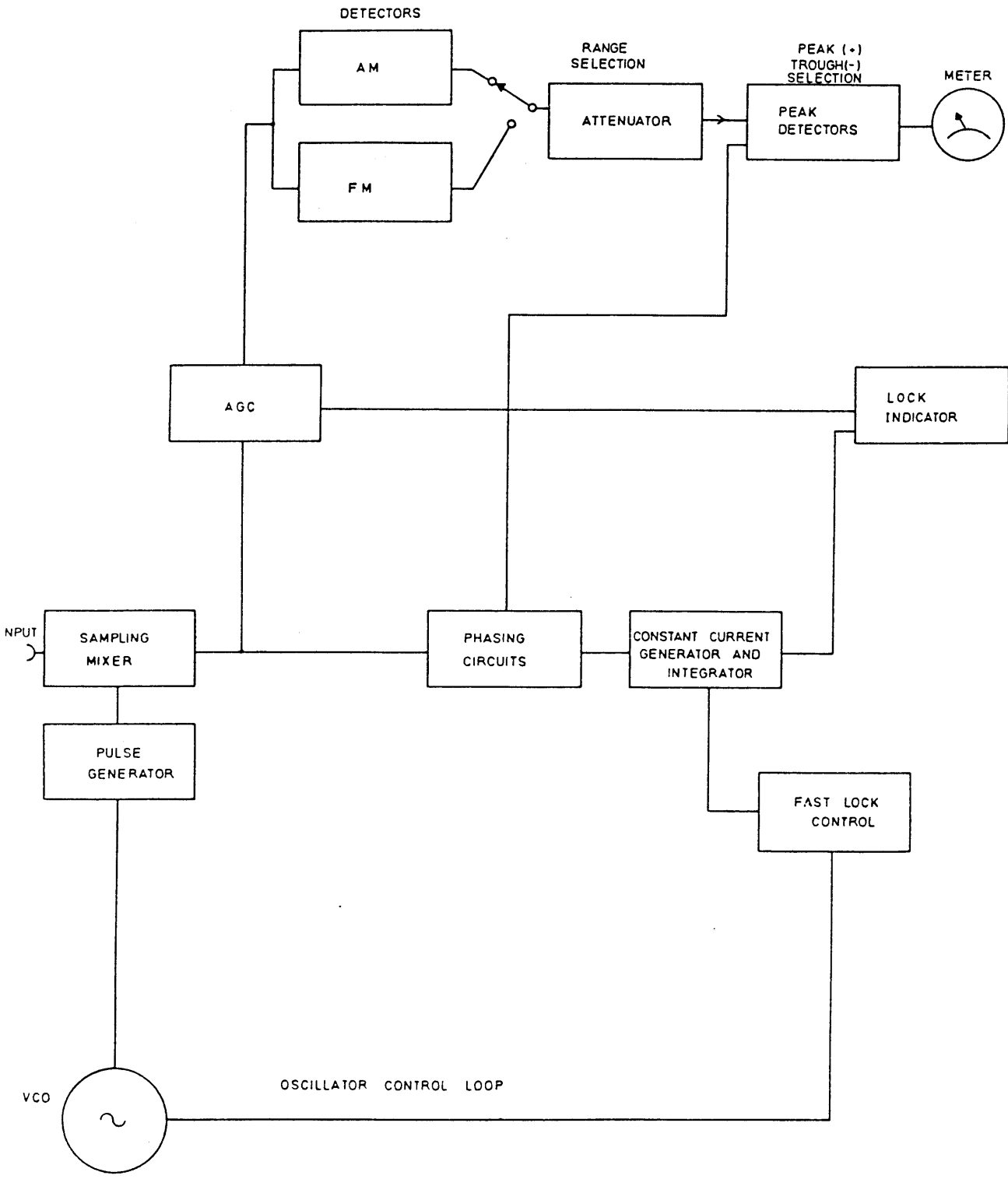

Simplified Block Diagram: 9008

Fig.3-1

3.5 For FM measurements the signal (i.f.) is applied to a pulse discriminator which has an output level proportional to frequency. The amplitude of this output waveform has a mean level which corresponds to the i.f. Variations from this level represent positive and negative peak deviations. These variations are 'peak and trough' detected and displayed as a meter reading.

Oscillator Tuning

3.6 The oscillator is tuned by voltage variable capacitance (varactor) control. The d.c. tuning voltage is obtained from the i.f. by means of a phase delay circuit controlling current pumps and an integrator. The system is preset so that the tuning null (lock) occurs when the i.f. from the sampling mixer is nominally 430 kHz, and circuit arrangements allow the oscillator to lock at a point either 430 kHz above or 430 kHz below the input signal, thus avoiding gaps in the frequency coverage. The rate of oscillator tuning is automatically increased when it is far off tune.

FUNCTIONAL DETAILS

3.7 The principles of the instrument will be now discussed in slightly greater detail, reference should be made to the more detailed block diagram Fig. 9 (at the back of the book).

Signal Input

3.8 Alternative front panel input sockets are provided. The 'high level' input feeds via a 20 dB attenuator whereas the 'low level' input signal is applied direct to the input of the sampling mixer.

Sampling Mixer

3.9 The divided output from the voltage controlled local oscillator drives a pulse generator, thus producing a train of narrow pulses (f_s) which are applied to an input of the sampling mixer. The external signal (f_i) which is applied to the other input of the mixer, is sampled by this pulse train. If a harmonic of the sampling frequency ' f_s ' is identical in frequency to the external signal, the output frequency from the sampling mixer (the i.f.) will be zero. When the two frequencies are not identical a 'difference' frequency output will be obtained.

3.10 The frequency relationship can be expressed by the formula:-

$$i.f. = (N.f_s - f_i)$$

where $N.f_s$ is that harmonic of f_s closest to the external signal f_i .

Oscillator Control Loop

- 3.11 The oscillator and control loop is mounted in the Lock Assembly (19-0805). The difference frequency (i.f.) from the Sampling Mixer is fed into the oscillator control loop via a low-pass filter and amplitude limiter, then via a $\div 2$ stage (A) to a phase delay and frequency discriminator circuit to the sweep drive stages.
- 3.12 Depending on the magnitude of the difference frequency (i.f.) the phase delay circuit with its associated selector gate, will determine the direction and speed of oscillator search by controlling the action of the current pumps. The operating principle of the loop control is based on the 'area' of the input signal, and the $\div 2$ stage (A) ensures that a 1 : 1 mark/space ratio is applied to the phase delay circuit even though the mark/space ratio of the input signal may not be precisely 1 : 1.
- 3.13 The preset phase delay circuit provides 90° phase delay at the required i.f., at the same time the undelayed signal is fed via the selector gate and the two signals are combined in a mixing gate. Provided the i.f. is correct, the mark/space ratio of the mixing gate output will be such as to produce a state of balance in the current pumps giving a steady d.c. voltage at the integrator which holds the oscillator in lock.
- 3.14 If the i.f. is not correct the phase delay will not be 90° . This produces a change in the mark/space ratio from the mixing gate which, via the current pumps, causes an error voltage to occur at the integrator. This integrated error voltage will tune the oscillator in the appropriate direction until a state of lock is achieved.
- 3.15 The oscillator can lock at a frequency above or below the input signal. This information is conveyed from the selector gate via the loop phasing control line to the peak (+) and trough (-) detectors in the Measurement p.c.b. to ensure that, when on f.m., the '+' and '-' deviation readings are in accordance with the setting of the front panel switch, the appropriate detector being enabled depending on whether the oscillator has locked above or below the input frequency.
- 3.16 The integrator output, as well as tuning the oscillator, is also applied via a high impedance voltage follower to the threshold detector, which via the $\div 2$ (B) stage, switches the phase of the selector gate to reverse the oscillator tuning direction whenever the tuning is near either end of its range. The threshold detector also applies a signal to the current divider to assist reversal of tuning direction.
- 3.17 If the oscillator is a long way out of lock the voltage follower feeds current into the integrator to speed up the tuning search. This current feed diminishes as the in-lock point is approached.

Out-of-Lock Indication

3.18 The gate marked OR on the Block Diagram (Fig. 9) controls a multivibrator which flashes the front panel IN LOCK lamp when either of the following conditions exist:-

(a) A signal from the integrator stage shows that tuning is in progress.

or

(b) A signal from the level detector shows that the input signal is too high or too low for reliable measurement.

A steady illumination must be obtained before a measurement is taken.

Measuring Circuits

3.19 Referring to the block diagram, Fig. 9, the i.f. from the sampling mixer is fed to the Lock Assembly on pin 1 and via a coaxial link on the p.c.b. to the a.g.c. circuit. From the a.g.c. circuit the level-controlled signal is fed out via pin 6 of the Lock Assembly, and applied simultaneously to the a.m. detector and f.m. limiter/discriminator in the Measuring Circuit Assembly 19-0805. The required function, a.m. or f.m., is selected by a control signal to the a.m./f.m. selector stage.

3.20 For accurate a.m. measurement the mean carrier level of the i.f. must be constant; this is ensured by feedback from the a.m. detector to the a.g.c. stage, and an a.g.c. reference level fed to the a.m. detector.

3.21 Following the a.m./f.m. selector the signal is fed through an audio filter to eliminate any trace of the i.f. and then through the range selection provided by three FET controlled attenuators. The modulation signal is then applied to two peak detectors for modulation depth or deviation measurement, and to the rear panel AF OUTPUT socket SK5. The input to one of the peak detectors is fed through a unity gain inverting amplifier to obtain the 'trough' reading.

3.22 The required peak detector is switched in by the PEAK/MEAN/TROUGH control circuit, and the output fed to a summing amplifier which feeds the meter drive stage and also supplies a d.c. signal to the rear panel socket SK6. For MEAN measurement both peak detectors are enabled simultaneously.

3.23 For signal level indication an output from the a.g.c. amplifier on the Lock p.c.b. is fed via SK1/24 to the summing amplifier through an FET switch controlled by a logic signal from switch S1. The same logic control signal inhibits the AM/FM selection FETs and allows the meter to give an indication of input signal level.

3.24 When the instrument is out of lock the meter is prevented from giving a reading by a mute signal from the In Lock multivibrator on the Lock p.c.b. This mute signal is fed in via SK1/26 to the muting FET in the AF Filter circuit.

Battery Check

3.25 When the 'battery check' switch on the battery pack is operated, a mute is applied via the rear panel connector PL4/15 to inhibit the measurement signals from the summing amplifier. At the same time the combined battery voltage is applied via PL4/10 to the meter drive circuit for a battery check reading.

SWITCHING SYSTEM

Introduction

3.26 Local and Remote control of functions is available. Referring to the block diagram, Fig. 9, the local function selection is carried out by applying +10V to switches S1 to S5, via SKT1 pin 11, when the LOCAL/REMOTE switch* (S10) is in the LOCAL position.

Remote Control

3.27 When the front panel LOCAL/REMOTE switch is set to REMOTE it causes the removal of the +10V from the 'local' operating switches S1 to S5, thus rendering them non-operative. Remote program operation is then available via the 15-way rear connector. Refer to Table 1 on page Tech. Spec. (5) for program logic. When LOCAL is selected the remote control input transistors are disabled, thereby rendering the remote program control non-operative.

3.28 In models not fitted with the LOCAL/REMOTE switch remote operation is selected by applying +10V to pin 11 of the rear connector. For further details refer to para. 5.10.

Local Selection Switches

3.29 Switches S1A/S1B are 2-pole switches giving 3-position selection. Consider switches S1A/S1B in Fig. 9. In AM mode both switches make the upper contact. When LEVEL is selected S1A moves to the lower contact but S1B does not move. When FM is selected S1B moves to the lower contact but S1A does not move. Switch S2 operates in similar manner for the TROUGH/MEAN/PEAK selection. A truth table for the switch contacts is given in Fig. 9.

*NOTE: On units with serial numbers 1701 to 1750 the selection of 'Remote' is enabled by a control voltage on the multiway connector (para. 5.10).

CHAPTER 4

TECHNICAL DESCRIPTION

INTRODUCTION

4.1 This chapter describes the significant features of the circuit design. The reader should have a clear understanding of the functional principles described in Chapter 3 and a basic knowledge of solid-state circuit theory and logic. The circuit descriptions will be dealt with under four main headings:-

- (a) The Sampling Mixer p.c.b.
- (b) The Lock p.c.b., which contains the frequency-locked loop, the local oscillator and the a.g.c. circuit.
- (c) The Measurement p.c.b. and Meter.
- (d) The power supply and battery charging system.

LOGIC CIRCUIT SYMBOLS

4.2 Extensive use is made of integrated circuits (IC's) and these are identified by a number and suffix letter. In the circuit description a particular IC pin will be identified by a reference such as 'IC2b/4' which indicates pin 4 on that particular gate or amplifier. The logic symbols used in the circuits are those found in most manufacturers IC data sheets to which reference should be made if detailed information is required.

SAMPLING MIXER ASSEMBLY 19-0803 (Fig. 1)

Introduction

4.3 Referring to the circuit diagram, Fig. 1 at the back of the book, the circuit may be considered, functionally, in three parts; the oscillator input and pulse generator on the left, the sampling mixer and signal input in the centre, and the i.f. output on the right.

Pulse Generator

4.4 The divided oscillator signal from the Lock Assembly is fed via pins 1 and 2 to the pulse shaper Q1, then via amplifiers Q2 and Q3 to the pulse generator. The step recovery diode D2 produces a very fast pulse across the printed wiring coil Lp, from the negative edge of Q3 collector output. The pulse across Lp is transferred via C8 to the transmission line transformer T1, which produces symmetrical anti-phase sampling pulses at A1 and B1.

Sampling Mixer

- 4.5 The external input signal is connected to the front panel socket SK2 (low level) or SK3 (high level) and fed via C11 and the 50Ω transmission line to the sampling bridge. The diodes D3, D4, D5 and D6 form a four-diode sampling bridge which, at the instant of sampling, transfers the instantaneous amplitude of the input signal at the junction of D3/D4 to the i.f. buffer amplifier Q4, Q5.
- 4.6 If the sampling and signal frequencies are harmonically related the voltage applied to Q4 will be at zero frequency (d.c.), but if a frequency difference exists the output signal will vary sinusoidally at this difference frequency (the i.f.). For a detailed discussion of sampling mixer principles reference should be made to a standard text book on the subject.*
- 4.7 The sampling mixer output is fed via a unity gain, high input impedance amplifier Q4 and Q5, to the i.f. output amplifier Q6/Q7, thence to the Lock Assembly, (Fig. 5).

AGC AMPLIFIER (Fig. 5)

Function

- 4.8 Although the a.g.c. amplifier is mounted on the Lock p.c.b. it provides the following facilities as part of the measurement process:-
- (a) Automatic level control of the i.f. signal before it is fed to the a.m. and f.m. detectors.
 - (b) Signal level information to the meter.
 - (c) Signal level 'out of range' information to operate the out of lock warning system.

AGC Circuit Description

4.9 Referring to the circuit diagram, Fig. 5, the i.f. signal from the Sampling Mixer is fed to pin 12 on the Lock p.c.b., and then via a coaxial link to pin 2, where it enters the a.g.c. amplifier via a low-pass filter between C50 and R91. The a.g.c. amplifier consists, basically, of Q41 and Q43 with control via 1C7. The overall gain is determined by the feedback via Q41, and the conducting state of Q41 is controlled by an error signal from 1C7/6.

* Digital and Sampled Data Control Systems by Tou (McGraw-Hill)

4.10 An a.g.c. reference voltage, provided by zener diode D23, is applied to IC7/3 and also via pin 4 of the p.c.b. to the a.m. detector in the Measurement p.c.b. The a.m. detector provides a signal ('a.g.c. feedback') on pin 9, which represents the average carrier amplitude at the a.m. detector. The unwanted a.c. component is filtered by C58. This a.g.c. feedback is compared with the a.g.c. reference and the error signal integrated in IC7 by C58. The integrated error signal is applied to the base of Q41, thereby varying the conductivity of Q41 so as to maintain an i.f. signal of constant amplitude at the a.m. detector, and hence at the collector of Q43. From Q43 the i.f. is fed via feedback amplifier Q44/Q45 and Q46 to the Measurement p.c.b. and to the rear panel i.f. output socket.

Signal Level Detection

4.11 The gain of the a.g.c. amplifier is inversely proportional to the direct current flowing in Q41. This current also flows in Q40, the emitter of which serves as a monitoring point for the level detection circuit.

4.12 The current from Q40 emitter is fed to the wiper of R117, where part of it flows to the virtual earth on pin 2 of amplifier IC8 whose gain is determined by the feedback components in the loop R116, R119, R120 and Q47. The output voltage from IC8/6 is fed via R114 and the 'level gate' (Fig. 3) to the 9008 meter for indication of the approximate input signal level.

4.13 To allow the meter to give a practical indication of input levels over the whole range (5 mV to 150 mV) the output voltage range of IC8 is 'compressed' by the action of Q47, which conducts at high signal levels, thus bypassing part of the loop resistance which reduces the amplifier gain and gives a non-linear characteristic to the meter response.

Out of Range Level Detection

4.14 Transistors Q49 and Q50 with feedback resistor R127 form a Schmitt Trigger which drives the control transistor for the IN LOCK multivibrator (Q33/IC6 in Fig. 6). It is arranged that the Schmitt output at the collector of Q50 will be a '1' if the signal level is in range, and a '0' if the level is out of range. The circuit operates by the action of Q48, as shown in Fig. 4.1

4.15 Assume that the output at IC8/6 is very low, (i.e. -10V) then Q48 will be non-conducting and the collector level high (point 'A' on Fig. 4.1). If the input voltage is increased Q48 will start conducting and the collector voltage will fall. At the point where the minimum specified input level is reached (Fig. 4.1 point B) the Schmitt will trigger and Q50 will go to '1', giving the in lock condition.

4.16 A further increase in input level will saturate Q48 (Fig. 4.1 point C). If the input level continues to increase, the collector of Q48 will be forced to follow the rising input level, until at point D on Fig. 4.1 the Schmitt will trigger back to the out of lock condition.

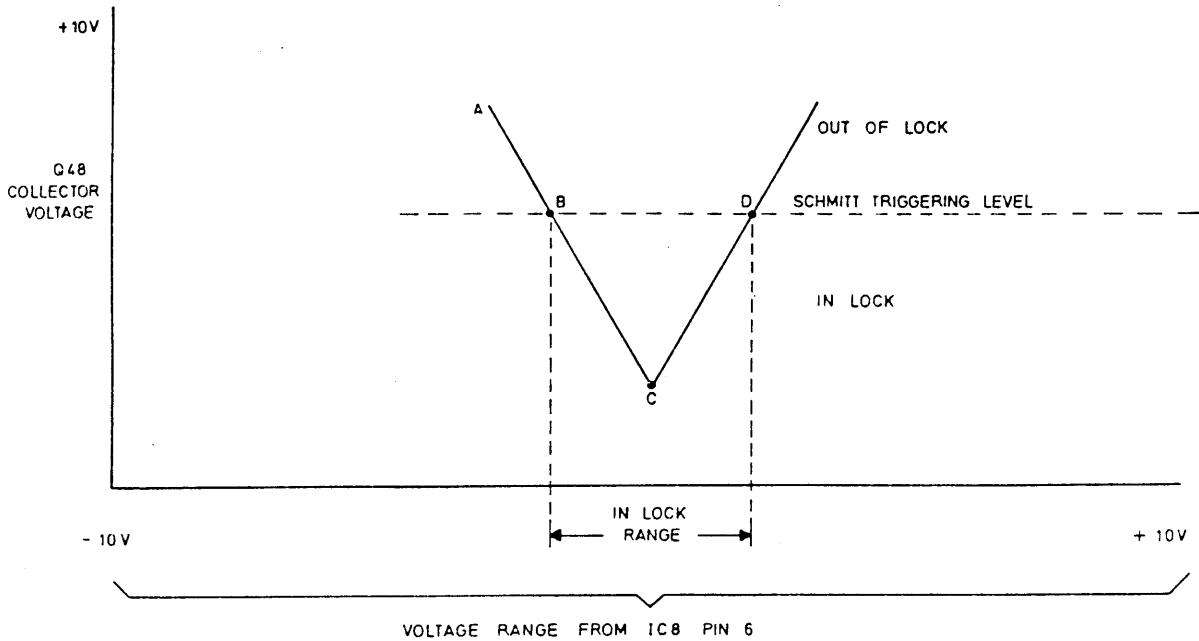

Level Detector Lock Indication

Fig.4.1

FREQUENCY-LOCKED LOOP AND OSCILLATOR CONTROL

Introduction

4.17 The circuitry for the frequency-locked loop and the local oscillator is mounted on the Lock p.c.b. Essential diagrams for reference are the circuit (Fig. 6) and the block diagram (Fig. 9) at the back of the book.

Lock Input

4.18 The i.f. signal from the sampling mixer enters the Lock p.c.b. at pin 12 and diverges into two paths, the a.g.c. and level detection path (described in paras. 4.8 to 4.10) and the oscillator lock path.

4.19 Referring to the circuit (Fig.6) the i.f. signal to the frequency-locked loop is fed via R1 into a low-pass filter which removes unwanted sampling mixer frequencies. The filtered signal is fed via C7 through Q1 and Q4, which are shunt feedback amplifiers with constant current supplies via Q2 and Q3 respectively. The limiter diodes D1/D2 and D3/D4 ensure that high level signals do not saturate the amplifiers.

4.20 Amplifier Q5 drives a $\div 2$ package whose output has a 1 : 1 mark/space ratio. The \overline{Q} output of IC1a is fed to a phase shift circuit via Q6/Q7, at the same time the Q and \overline{Q} outputs are both fed to the selector gate IC2a, IC2c and IC2d. The collector supply to the circuit between Q5 and Q9 is a -5V rail stabilized by Q10, which holds this rail at a level 5V above the -10V supply. Thus, any error in the -10V supply will affect this -5V rail.

Phase Shift Circuit

4.21 The phase shift circuit is formed by Q6/Q7 with R17, C15, C17 and L3. The circuit is adjustable by C17 to provide an exact 90° phase delay at the required i.f. Below the required i.f. the phase delay will be less than 90° , whereas above the i.f. the phase delay will be greater than 90° . The phase delayed signal is fed via amplifiers Q8 and Q9 to the mixing gate IC2b.

Selector Gate

4.22 The Q and \overline{Q} outputs from the divider IC1a are fed to the selector gate via IC2a/1 and IC2d/13. The Q and \overline{Q} signals from IC1b are also applied to this gate and these determine which of the IC1a signals (Q or \overline{Q}) is fed to the mixing gate, thus deciding the direction of oscillator search. The Q signal from IC1b is fed to the measurement p.c.b. via pin 23 to inform the peak detectors of the loop phasing to ensure correct deviation selection on f.m.

Mixing Gate

4.23 The phase shifted signal in Q9, and the 'direct' signal via the selector gate, are fed to the NAND mixing gate IC2b. The output from IC2b/6 drives a current generator Q11 via R28, and this in turn drives a summing junction which is the common line joining Q14 collector, Q11 collector, R36, R37, C25 and R58.

4.24 The output from the mixing gate (IC2b/6) is a pulse waveform whose mark/space ratio varies with the frequency of the i.f. from the sampling mixer. At the required i.f. the 90° phase shift ensures that the mark/space ratio at IC2b is 3 : 1. Variation of the i.f. will vary the mark/space ratio and hence will vary the average current flowing in Q11 collector.

Current Pumps and Integrator.

4.25 The integrating capacitor is C25 which also smooths the pulsed output from Q11.

A constant current is fed via Q14 into C25 and a current flows out via Q11 at a rate determined by the mark/space ratio of the mixing gate output (para.4.24). When the correct i.f. is obtained, these two currents are in balance and the local oscillator is held in lock due to the steady voltage on C25.

4.26 Temperature compensation for the constant current generator Q14 is provided by Q12, and compensation for Q11 is provided by Q13. This maintains the correct current balance for the required i.f. over the temperature range. The adjustment of R34 is described in para. 5.17.

Current Divider and Oscillator Tuning

4.27 The voltage due to the 'error' current flowing into or out of C25 is applied to a current divider circuit to reduce the sensitivity of the oscillator tuning. The current divider is basically IC3, the dual FET package Q15a/Q15b and associated resistors. The tuning voltage to the oscillator is applied across capacitor C27. The link LK1 allows the loop to be broken for tuning by external d.c. voltage (-5V to +5V) for fault location purposes. See page 5-9. The action of the current divider is illustrated by the simplified circuit Fig. 4.2 which may be compared with the circuit in Fig. 6.

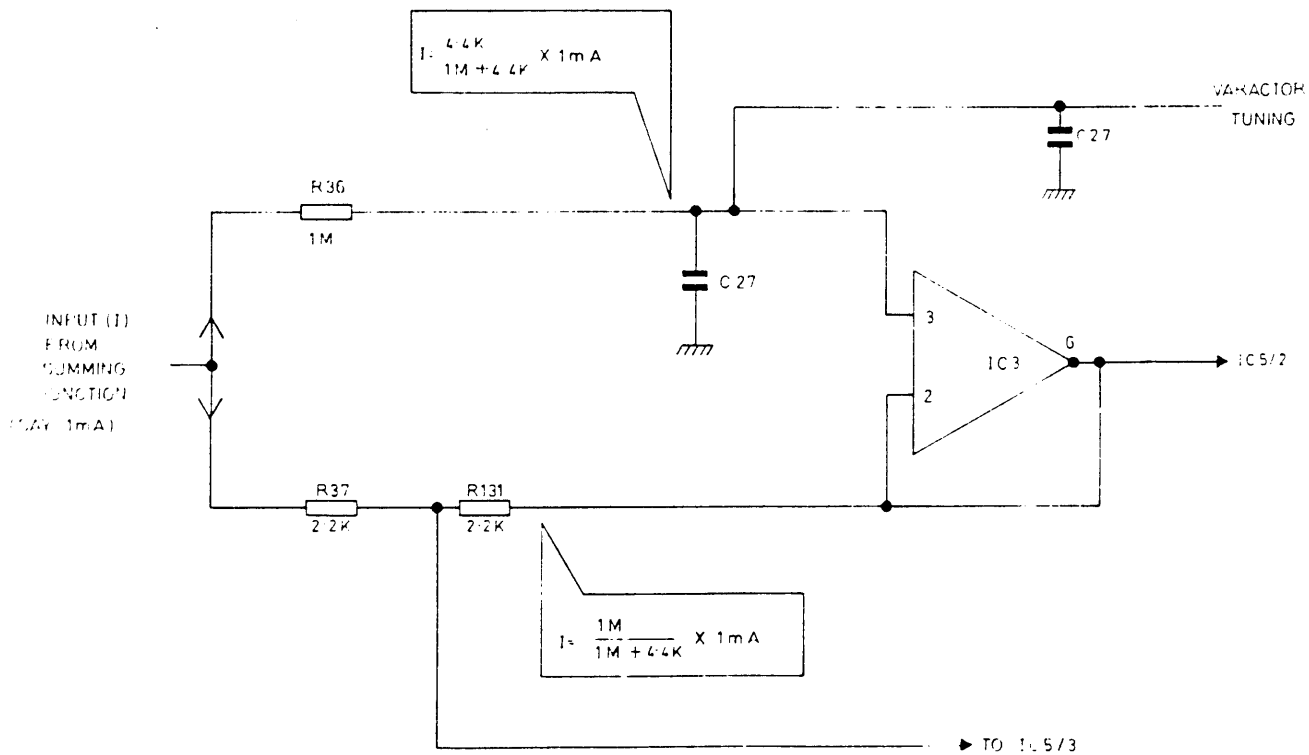

Simplified Circuits: Current Divider

Fig 4.2

4.28 Operational amplifier IC3 is connected in a voltage-follower configuration such that pins 2 and 3 are always at the same potential. Transistors Q15a/Q15b simply provide a high impedance buffer between IC3 and the summing junction and do not affect the theoretical argument.

4.29 Referring to Fig. 4.2, assuming an input 'error' current from the summing junction of 1 mA, this current will divide by Kirchoff's law between the 1 M Ω and 4.4 k Ω

branches, such that only $\frac{4.4}{1004.4}$ mA will flow into C27 and C26 the remaining current

$\left(\frac{1000}{1004.4} \text{ mA}\right)$ flowing through R37 and R131 to IC3/6. Thus the greater part of the input current will not directly affect the oscillator tuning, but is detected by the fast lock circuits as a measure of the frequency error in the i.f.

Fast Lock Circuit

4.30 IC5 compares the oscillator tuning (varactor) voltage with the error signal derived from the integrator C25. If the difference is large IC5 will cause Q29 or Q30 to feed additional current into or out of C27, to speed up the oscillator tuning, as follows.

4.31 The varactor line voltage is duplicated on IC3/6 by its voltage-follower action, and is applied to IC5 together with a reduced version of the error signal from the junction of R37 and R131. These are compared, amplified by IC5 and applied to the low impedance drivers Q29/Q30, which rapidly pull the varactor line (and consequently C27) to within 0.7V of the required voltage. When the correct i.f. is obtained (i.e. locked) IC3/6 and IC5/6 will be at the same voltage, and Q29 and Q30 will both be turned off and therefore have no further influence on the oscillator tuning.

4.32 In models up to serial number 2000 additional components R88, C26 and Q16 were fitted in order to control the loop lock-up time, as described in Issue 1 of the manual.

Out of Lock Signal

4.33 Provided the oscillator tuning has locked, and the input signal level is satisfactory, the in-lock multivibrator IC6 will be non-active and the front panel IN LOCK indicator will give a steady illumination. If either of these conditions is incorrect the multivibrator will turn on, causing the IN LOCK indicator to flash as described below. The circuit details which follow refer to serial numbers commencing at 2001.

4.34 The oscillator out of lock condition is monitored by Q32 in response to the collector currents in Q30 and Q31. (The current in Q31 is identical to that in Q29 collector). If the current in Q30 or Q31 collector is sufficient to produce a turn-on voltage at the base of Q32, then Q32 will conduct. This turns on Q34, which via R86, causes Q33 to turn off, and the IN LOCK lamp LP2 to flash, via the multivibrator IC6.

4.35 Multivibrator IC6 will also operate if a signal from the level detector (Fig. 4) indicates that the input level is too low or too high (logic '0'). This signal is received at point X on Fig. 6, which is the common 'out of lock' line, and fed to the base of Q34 which turns on, causing the junction R86/R87 to go sufficiently negative to turn off Q33. Capacitor C42 'damps' the action of Q34, thus avoiding a jittery type of lock indication when the oscillator is close to the limit of lock.

Mute Output

4.36 When the instrument goes 'out of lock' a '0' mute level is fed out on pin 14 to PL1/26 on the measuring circuit (Fig. 3 Q58) to inhibit the output of the active filters.

4.37 Commencing at serial number 2001 the circuit around Q34 is re-designed to speed up the mute action. When the out of lock condition sends Q32 collector low it turns on Q34. As Q34 collector rises it feeds current via R78 to the base of Q32, thus turning Q32 (and hence Q34) hard on. C40 speeds up the regenerative action.

External Lock Indication

4.38 The lock monitor level at the collector of Q32 controls Q34 as described in the previous paragraph, and Q34 drives Q35 to produce a d.c. in or out of lock signal at pin 13, for external use. When the instrument goes 'out of lock' Q34 emitter goes to approximately -9V, and Q35 turns on, although its base cannot go more negative than 0V due to D20. Thus the out of lock t.t.l. level at Q35 collector is a true 0V.

4.39 When the instrument is in lock Q34 and Q35 are turned off, but the maximum positive level at Q35 collector is held at approximately +5V by zener diode D21.

Threshold Detector

4.40 The threshold detector is the circuit around Q23 to Q27 and its function is to detect when the oscillator tuning voltage is near the top or bottom of its range and to initiate the following action:-

- (a) To reverse the direction of oscillator tuning by changing the polarity of the signal in the selector gate (via Q23 and IC1b).
- (b) To apply a current step, via D15 or D16, to the summing junction to ensure a prompt reversal of tuning polarity.

4.41 The threshold detector is driven by the voltage at IC3/6 which is a voltage-follower version of the oscillator (varactor) tuning signal. From IC3/6 the signal is fed via R71 and D18 to the emitter of Q27 when the varactor level is high, and via D17 to the emitter of Q24 when the varactor level is low.

4.42 Assume that the varactor tuning level has reached its maximum positive level; and that Q27 is turned on, which turns on Q26. A regenerative action develops which turns Q27 hard on, and via R70 turns on Q23. The resulting edge at Q23 collector clocks the bistable IC1b, which changes the input selection (\bar{Q} or Q) at the selector gate IC2a/IC2d. This changes the loop phase by 180° and causes the appropriate harmonic of the oscillator to lock up on the opposite (image) side of the input signal frequency. A signal is also sent from IC1b/9 to select the appropriate '+' or '-' deviation detector in the measuring circuit.

4.43 If the varactor tuning level falls to the lower limit, Q24 is turned on via D17 and a regenerative action develops with Q25, similar to the action in the previous paragraph. Q23 is turned on via R57 and IC1b is clocked to reverse the polarity of the selector gate signal.

4.44 Current pulses are fed to the summing junction via D15, D16 and R58 whenever the oscillator varactor tuning reaches an upper or lower limit. This forces the summing junction, and hence the varactor line, to return to the normal operating range.

Oscillator and Divider

4.45 The oscillator is a field effect transistor Q18, with tuning by voltage variable capacitance (varactor) diodes D12 and D13, operating in a Colpitts type circuit. The oscillator output is fed from a tap on transformer T1 to the base of an over-driven amplifier Q20, which feeds a square-wave output to the $\div 2$ package IC4a. From IC4a/12 the divided oscillator signal is fed to the sampling mixer (Fig. 1). The +10V and -10V supplies are filtered and stabilized by Q19, Q21, Q22 and associated components to ensure a minimum of noise or hum voltage on the oscillator output.

MEASURING CIRCUITS PCB: 19-0804 (Fig. 3)

Introduction

4.46 The measuring circuits are shown in Fig. 3, but reference should also be made to the a.g.c. amplifier which is mounted on the Lock p.c.b. (Fig. 5) and described in paras. 4.8 to 4.16. The block diagram, Fig. 9, shows the main functional blocks of the system.

Measurement Input

4.47 The i.f. is fed from the a.g.c. amplifier (in the Lock p.c.b.) to pin 1 of the Measuring p.c.b. From pin 1 the i.f. is fed in parallel to the a.m. detector via C12 and to the f.m. limiter and discriminator via C1.

AM Detector

4.48 The a.m. detector is the feedback amplifier Q24/Q25/Q26 together with diodes D8 and D9 and resistor R65, connected in a conventional half-wave rectifier circuit, as shown in Fig. 4.3. The 3.9V reference from the a.g.c. stage is applied, via PL1/9, to the base of Q25, thus the detected a.m. component will be added to this 3.9V reference.

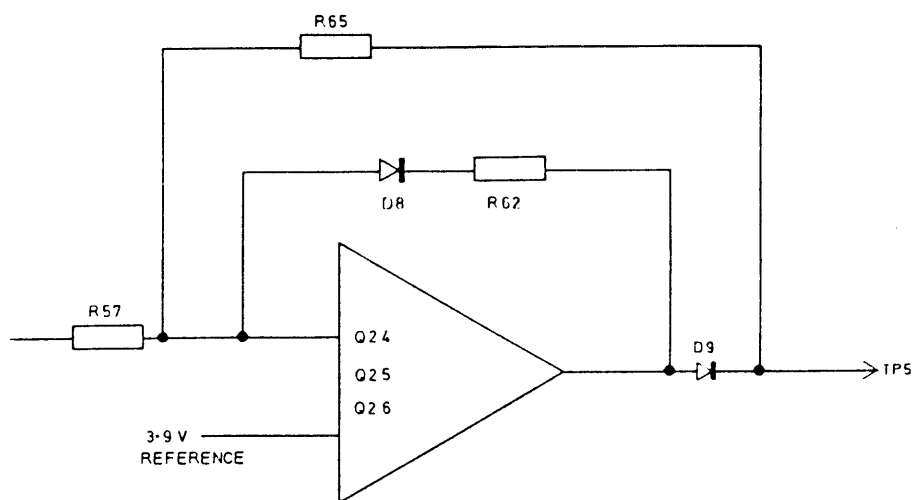

AM Detector:Equivalent Circuit

Fig.4.3

4.49 Under stable operating conditions the half-wave rectified output has a level of 3.9V (reference) plus a mean level of approximately 0.5V for the superimposed positive half cycles. This 4.4V signal is applied via R64 to the a.g.c. control line (PL1/1) and fed to the a.g.c. circuit in the Lock p.c.b. where the combined attenuation of R64 with R92/R93 reduces the level to 3.9V.

4.50 The detected signal is fed from the emitter of Q27 to the AM Calibration potentiometer R66 and to the FET Q63 in the AM/FM selector circuit. (The AM/FM selection is described in para. 4.57).

FM Limiter and Discriminator

4.51 Transistors Q13/Q14 with Q16 are arranged as a limiting amplifier which saturates when driven by the constant i.f. signal, thus providing a square wave output at Q16 collector.

4.52 The d.c. supply is +10V and potential divider R35/R36 ensures that the base of Q13 is biased to +5V, therefore with no external signal applied the base of Q14 will acquire a mean level of +5V. When a signal is applied the output at Q16 collector will be a square wave with 1 : 1 mark/space ratio, a mean level of +5V and peak to peak amplitude of approximately 9V.

4.53 The significant components of the FM Discriminator are Q18, R44, C7, D3 and Q19. Transistor Q18 is a saturating amplifier driven by the square wave output from Q16 and thus switches on and off at the frequency of the i.f. signal. When Q18 is conducting it draws a charging current through D3 into C7.

4.54 When Q18 turns off the junction R44/C7 attempts to rise to +7V (see para. 4.56). This voltage is effectively added to the stored voltage in C7 and thus forward biases the base-emitter junction of Q19 which allows the stored charge in C7 to be transferred to the collector circuit of Q19. The output from Q19 therefore consists of a succession of current pulses at the switching frequency of Q18. This pulse type output is filtered by C9 in the amplifier Q20/Q21, the mean output voltage being determined by R48.

4.55 Since the quantity of energy stored in C7 in a given time period is proportional to the switching frequency of Q18, it follows that the mean voltage at the output of the amplifier Q20/Q21 will be proportional to the frequency of the i.f. and hence will vary according to the frequency deviation. From Q21 the output is fed via a calibrating potentiometer R54 to the FET Q57 in the AM/FM selection circuit, (see para. 4.58).

+7V Stabilization

4.56 A stable +7V supply is essential to ensure a constant amount of charge in C7, for FM detection. Transistors Q22 and Q23 form the stabilizer circuit which functions on conventional lines; the diodes D5, D6 and D7 provide temperature compensation which ensures stable performance in the f.m. discriminator.

AM/FM Mode Switching

NOTE: Refer to the overall block diagram, Fig. 9 for switch connections.

4.57 Referring to the circuit, Fig. 3, the a.m. signal path is from Q27 via R66 through FET's Q63/Q62 to the common a.f. amplifier Q28/Q29. When the AM/LEVEL/FM switch is set to AM, a '1' is applied via PL1/3 on the Measuring p.c.b. to the base of Q55. The resulting '0' at Q55 collector turns Q56 off and Q59 on, which inhibits the f.m. path and also turns off Q61. When Q61 goes 'off' it removes the forward bias from diode D23, which then no longer acts as a low impedance clamp on the a.m. path, thus allowing the signal to pass via Q62 to Q28. When FM is selected, on the other hand, the '0' at Q55 base turns on Q61, thus causing Q63, Q62 and D23 to act as a 'T' attenuator, the two FET's, being turned off, offer a high series impedance and D23 a very low shunt impedance, which inhibits the a.m. signal.

4.58 The f.m. signal is switched via Q57 and Q60 by the action of Q59 in a manner similar to that described in the previous paragraph. The f.m. signal is fed through Q57 and Q60 so long as Q59 is held off by the '0' at Q55 base (FM selected). When AM is selected, however, Q59 is turned on, which forward biases D22, giving a low impedance to earth which inhibits the f.m. signal.

AF Filters

4.59 From the a.f. amplifier Q28/Q29 the selected a.m. or f.m. signal is fed through a chain of two active filters and one passive filter to eliminate the unwanted i.f. and restrict the bandwidth to a nominal 50 Hz to 30 kHz (or to 300 Hz to 3 kHz with AF FILTER switch at IN).

4.60 The output from Q29 emitter is applied via C15 to the first active filter formed by Q30 and Q31 with components R71, R76, C18 and C19. The amplifier Q30/Q31 has unity overall gain and feeds into the second active filter via C20.

4.61 The second active filter circuit is centred on Q33/Q35 and is essentially of the same design as Q30/Q31 but with additional capacitors, selected by the front panel AF FILTER control. The capacitors are switched via the FET's Q32 and Q34 and change the upper passband frequency from 30 kHz to 3kHz.

4.62 When the AF FILTER switch is set to IN, (see Fig. 9) +10V is applied via PL1/5 and R3 to the base of Q2, which turns off Q3 and allows the FET's Q32 and Q34 to turn on. When Q32 conducts it connects capacitors C21/C23 in parallel with the filter feedback capacitor C24, and similarly Q34 connects C25/C26 in parallel with the filter shunt capacitance C22. The combined effect is to limit the upper frequency of the passband to 3 kHz. When the AF FILTER switch is at OUT, the FET's Q32 and Q34 are turned off.

4.63 The third a.f. filter is between Q58 and Q38. The output of the second filter at Q33 emitter is fed to the drain of Q58, which is conducting except when a mute signal ('0') is connected to its gate via D24 from the 'out of lock' circuit on the Lock p.c.b.

4.64 From Q58 source the signal is fed via R88, R87, C28, C29 and R91 to Q38. When the AF FILTER switch is at IN the FET Q36 is turned on and Q37 is turned off. This bypasses R87 to give compensating gain and introduces C28 to raise the lower frequency of the passband from the 50 Hz cut-off up to about 300 Hz.

Attenuators (Meter Ranges)

4.65 The 6 dB, 10 dB and 20 dB attenuators are similar in design, the required attenuator being inserted or removed by a switched FET connected in parallel with a part of each resistor chain. The switched FET's Q39, Q41 and Q43 are switched by logic levels from the front panel METER RANGE switches via transistors Q6, Q10 and Q8.

4.66 The 6dB attenuator, for example, consists of resistors R95, R94 and R96. The FET Q39 is turned off when the 6 dB attenuator is required, by setting the METER RANGE toggle switch to the 3-100 position (see Fig. 9). This applies a '1' via PL1/14, which turns on Q6 and applies a '0' to D14 which turns off Q39, thus removing the bypass from the resistors R94 and R95.

4.67 In a similar manner the 10 dB attenuator is switched by Q41 via control transistor Q10, and the 20 dB attenuator by FET Q43 via control transistor Q8. When on remote control the transistors Q7, Q9 and Q11 are enabled to allow remote control signals to operate the control transistors.

Peak (+) Trough (-) and Level Outputs

4.68 From the attenuators the a.f. signal is fed through the three-transistor amplifier Q44, Q45 and Q46, thence via C37 and potential divider R114/R115 to an a.f. output on the rear panel. Also from Q46 collector the a.f. signal is fed via C35 to peak detector Q49 for modulation 'peak' information, and via C36, R113 and inverting amplifier IC4 to peak detector Q50 for 'trough' information.

4.69 The bases of Q49 and Q50 are connected to a biasing network which includes the diode-connected transistors Q47 and Q48 with resistors R116, R118 and potentiometers R120 and R171 network compensates for the unequal V_{be} figures of the two peak detectors by adjusting the bias on Q50 base. The procedure is described in Chapter 5 (para. 5.26).

4.70 Each peak detector provides a positive output which is fed via the respective FET switches Q51 (peak) and Q52 (trough) to pin 3 of the unity gain voltage-follower operational amplifier IC1. From IC1 the selected output is fed via potentiometer R134 to the meter and via potential divider R135/R136 to the rear panel DC output. When the 'mean' modulation level is required Q51 and Q52 are both turned on, which feeds both peak detector outputs simultaneously to IC1. The switching control of Q51 and Q52 is described in para. 4.74.

4.71 When measuring f.m. deviation the peak (+) and trough (-) detector outputs are selected via the FET switches Q51 and Q52 as for a.m., except that the particular FET selected is determined by a signal from the loop phasing control (PL1/22) according to whether the local oscillator (harmonic) has locked above or below the input signal frequency.

4.72 For example, if the i.f. produced in the sampling mixer is such that:-

$$IF = F_{in} - F \text{ (local oscillator)}$$

then the deviation on the i.f. will be in agreement with the deviation on the input signal (F_{in}). Conversely, if the i.f. is produced in the sampling mixer such that:-

$$IF = F \text{ (local oscillator)} - F_{in}$$

then the deviation in the i.f. will be opposite in direction to the deviation on the input

signal. It is the purpose of the loop phasing signal to ensure automatically that the deviation direction ('+' or '-') selected by the user always relates to the deviation on the input signal.

4.73 When LEVEL is selected at the front panel switch S1 (Fig. 9) +10V is applied via PL1/27 to D20 which turns on Q53, and to D21 to turn on Q59 and Q61. This allows the 'level' signal from the Lock p.c.b. to pass to the meter via Q53, IC1 and R134, while Q59 and Q61 cause signals from both the f.m. discriminator and the a.m. detector to be muted.

Peak/Mean/Trough Switching

4.74 As described in para. 4.70, the peak detector outputs are selected by the FET switches Q51 and Q52, and these are controlled via transistors Q67 and Q68. The conducting states of Q67, Q68 and the FET switches for the different modes are as follows:-

<u>Mode</u>	<u>Q67</u>	<u>Q68</u>	<u>Q51</u>	<u>Q52</u>
Peak (AM)	off	on	on	off
Trough (AM)	on	off	off	on
Mean	off	off	on	on
+ (FM)	}	As for AM (Peak and Trough) except that the loop phasing control will reverse the selection according to whether the oscillator has locked above or below the input signal frequency (see para. 4.72).		
- (FM)				

NOTE: The term 'mean modulation' in this instrument is defined as:-

$$\frac{\text{Peak Reading} + \text{Trough Reading}}{2}$$

4.75 The control logic (+10V) is provided by the PEAK/MEAN/TROUGH switch S2 (Fig. 9) and applied to the logic network IC2 and IC3 via PL1/18 and Q4, and via PL1/20 and Q66. The loop phasing control is applied via PL1/22 to IC2d/12. When AM is selected, however, IC2d/13 is to be held at '0' by the collector of Q55, thus inhibiting the gate. In FM mode the inhibit is removed. A stabilized -5V supply to IC2/IC3 is provided via D25 and R157.

Local/Remote Selection

4.76 Referring to the Measuring circuit, Fig. 3, reference has been made in the circuit description to the various local control transistors. The same control paths are used on 'Remote' via a series transistor (Q1, Q5, Q7, Q9, Q11, Q54 or Q65) in each line. Each series transistor is enabled by an earth to the base, via

PL1/23, when the LOCAL/REMOTE switch S10* (Fig. 9) is set to REMOTE.

4.77 The 'local control switches S1 to S5 (Fig. 9) receive a +10V supply for switching logic via transistor Q12 in the Measuring p.c.b. On LOCAL the switch S10 maintains this supply by an earth to Q12 base (via PL1/10). When REMOTE is selected this earth line is open-circuited and Q12 turns off, thus disabling the local controls.

Battery Check

4.78 When the Check switch on the battery pack is operated an earth (Mute) is applied to PL1/30 on the Measuring p.c.b., which inhibits the meter drive voltage from IC1. At the same time the battery voltage is applied via PL1/28 and R170 to the meter, with R168 in parallel.

POWER SUPPLY

Introduction

4.79 The power supply circuit is shown in Fig. 8 at the back of the book. It comprises the power supply p.c.b. 19-0806, together with the panel and chassis mounted items such as switches, fuses, voltage selector, transformer, rectifier etc.

NOTE: A truth table giving the functions of the Supply Voltage selection switches is given in Chapter 5 (Table 6).

AC (Mains) Operation

surge fuse FS1 to the voltage selector switches S6 and S7 and mains transformer T1.

4.81 The mains transformer T1 has dual primary windings with tapings which can be connected, by rear panel switches S6 and S7, to provide four alternative voltage ranges. Instructions for setting the voltage selector are given in para. 5.2.

4.82 The secondary voltage from T1 is rectified by the chassis mounted bridge rectifier D10 and the d.c. output is smoothed by C7 and C8. The LED POWER ON indicator LPI is illuminated when the a.c. supply is connected, irrespective of the position of the POWER switch. Instructions for setting R19 are given in Chapter 5.

* NOTE: In serial numbers 1701 to 1750 the Local/Remote switch is not fitted and remote control is obtained by plugging in the rear connector PL4, with appropriate logic connections. (See pages Tech. Spec (5) and Tech. Spec (6).

Power Supply (Stabilizer) PCB 19-0806 (Fig. 8)

- 4.83 With the rear BATTERY/MAINS switch, S8, set to MAINS, the positive d.c. supply from D10 enters the p.c.b. at pin 11, and is fed via a current sensing resistor R8 to the chassis mounted series regulator Q14. The regulated current is then fed via POWER switch S9c (ON position) to the instrument, or (via the OFF/CHARGE position) to the battery via D2.
- 4.84 +10V Stabilization. Stabilization of the positive rail is conventional. The output level is sampled at R19 and compared in IC1 with a zener reference level provided by R17/D4. If for example the positive rail tended to rise above +10V, it would cause a negative shift at IC1/6, which would tend to turn off Q7, thus reducing the base current in Q14 and correcting the voltage error.
- 4.85 Current Limiting. Two forms of current limiting are provided by the circuit associated with Q4 and Q6, one for normal operation and the other for battery charging.
- 4.86 Referring to the circuit diagram Fig. 8, consider first normal operation. With the POWER switch S9c at ON, no voltage is applied to pin 7 and therefore Q6 is turned off. The base of Q4 is connected via R10 to the junction of R8 and Q14 emitter, and, if the current through R8 reaches approximately 0.6 A, Q4 will begin to conduct and feed current into IC1 pin 2. This will tend to reduce the collector current in Q7 and thus limit the current through Q14.
- 4.87 Now consider the CHARGE conditions, first with no battery connected. With switch S9c in the OFF/CHARGE position, the voltage on pin 20 is fed via pin 7 to R22, which causes Q8 to turn on. This draws current from IC1/2 through R21, which via the regulating system, causes the voltage at pin 20 to rise to approximately +16V for charging purposes. The voltage at pin 7 also causes Q6 to draw current through R10, and the resulting small voltage drop means that less voltage is required across R8 in order to turn on Q4, thus the current limit is reduced. When a battery is connected, and with switch S9c in the CHARGE position, pin 7 assumes a voltage 0.7V higher than the battery voltage (due to diode D2). Therefore, depending on the battery voltage, Q6 will draw more or less current through R10 and will limit the charging current in inverse proportion to the battery voltage. Thus with a fully charged battery the current limit will be a minimum and with discharged battery the current limit will be a maximum.
- 4.88 -10V Stabilization. The negative rail derives its stabilizing reference from the +10V rail, therefore the +10V regulator must be checked, before suspecting a fault in the -10V supply.
- 4.89 Resistors R24 and R38 are of equal value and connected as a potential divider between the +10V and -10V rails. The midpoint of the divider is connected to pin 2 of IC2 and compared with the 0V reference at pin 3 of IC2. Provided the voltage of the negative rail is equal to that of the +10V rail, both inputs to IC2 will be at 0V.

Any voltage difference will, however, generate an output at IC2/6 which via Q13 will control the base current of the regulator Q15, such as to correct the error.

4.90 Current limiting on the negative rail operates in a similar way to that described in para. 4.87. The negative charging path is from rectifier D10, via switch S8b (MAINS position) Q15, switch S9d (OFF/CHARGE position) pin 4, D6 and pin 3 to the negative battery.

Power Supply Low Voltage Inhibit

4.91 An automatic power cut-off operates if supply voltages are too low. If a very low mains supply is connected, the regulating transistor Q14 could saturate, possibly causing false readings. Alternatively, if the instrument is being operated from batteries it is desirable not to discharge the batteries completely, but to disconnect them if they are approaching the discharged condition. If either of these power conditions occurs the series regulator Q14 will automatically be turned off, thus cutting off the power to the remainder of the instrument. This protection is carried out by Q1, Q2 and associated circuit.

4.92 The system operates by turning on Q2 when the d.c. voltage on either the positive or negative rail is too low. This applies current to IC1/2 which via Q7 turns off the regulator Q14. The circuit operates as follows:-

4.93 The emitter of Q1 is held by D3 at 5.6V below the input supply rail and the base samples the d.c. supply voltage at the junction of R2 and R3. Under normal conditions the base voltage is lower than the emitter and Q1 does not conduct. With Q1 off, Q2 is held off and IC1 is unaffected.

4.94 If the voltage on the positive rail falls below about +9V, Q1 will turn on, causing Q2 to turn on, thus feeding current to IC1/2, thereby causing IC1 and Q7 to turn off Q14.

4.95 In the negative supply section, Q9 controls Q2 in the manner described in the previous paragraph. The sampling point is at the junction of R26 and R27 and the emitter level is fixed by D7. In fault diagnosis it should be noted that if the +10V supply is turned off it will automatically cut off the -10V rail because the negative regulation is derived from the +10V rail. If the fault has occurred only in the -10V supply, then the +10V supply will be normal.

Battery Trickle Charging

4.96 With the BATTERY/MAINS switch S8 at MAINS and POWER switch S9 at ON the rectifier D10 supplies the instrument via contacts S8a and S8b, and thence trickle charging through R1 and D1 to the positive battery via pin 6. The trickle charge to the negative battery is fed via R25, D5 and pin 3. The trickle charging current continues so long as mains power is connected to the instrument and the BATTERY/MAINS switch is at MAINS.

Battery Full Rate Charging

4.97 With the BATTERY/MAINS switch S8 at either MAINS or BATTERY position, full-rate charging of the batteries will be obtained provided the POWER switch S9 is set to OFF/CHARGE, and a.c. power is connected. In this mode the batteries are charged under constant current conditions, as explained in paras. 4.87 to 4.90.

Battery-Powered Operation

4.98 For battery operation switch S8a must be in the BATTERY position and S9a in the ON position.

Reversed Polarity Protection

4.99 Diodes D8 and D9, together with the battery fuses, provide reversed polarity protection. If a battery is connected with reversed polarity D8 and D9 offer a virtual short circuit to earth and will blow the 500 mA fuses in the battery pack. It is, therefore, essential that any external d.c. supply is fitted with a 500 mA fuse in each input line.

CHAPTER 5
MAINTENANCE

POWER SUPPLY

Supply Voltage Selection

- 5.1 Mains voltage selection is by two rear panel slide switches S6 and S7. Refer to Table 6 and set the slide switches S6 and S7 to the positions for the required voltage range.

TABLE 6
Mains Voltage Selection

Switch Settings		Instrument Voltage Range For Local AC Supply
S6	S7	
Y	X	94 to 110V
Y	W	110 to 130V
Z	X	188 to 220V
Z	W	220 to 260V

Fuse Check

- 5.2 Check that the power fuse on the rear panel has the correct rating for the supply voltage, as follows:-

188 to 260V supply	80 mA)	antisurge fuse
94 to 130V supply	160 mA)	must be used

There are no internal fuses.

DC Fuses

- 5.3 The optional battery pack has a 500 mA fuse in each line (+10V and -10V).

IMPORTANT NOTE:

If a d.c. supply is provided by the customer it is essential that it be fitted with 500 mA fuses (normal quick action type) in the respective +10V and -10V lines, to ensure reversed polarity protection.

Power Lead

- 5.4 Fit a suitable plug to the power lead supplied, in accordance with the standard colour code:-

Brown Line
Blue Neutral
Green/Yellow Earth (Ground)

REMOVAL OF COVERS

WARNING: DANGEROUS AC VOLTAGES ARE EXPOSED WHEN COVERS ARE REMOVED WITH AC SUPPLY CONNECTED

- 5.5
- (1) Switch the instrument POWER switch to OFF/CHARGE and switch off the a.c. supply at the bench outlet. Unplug the power lead from the rear panel of the instrument.
 - (2) If the bottom cover is to be detached, remove the four screws from this cover.
 - (3) Remove the rubber plugs, (located near to the rear end) from both side panels of the instrument and slacken, by about two turns, the screws revealed.

- (4) Grip the rear panel assembly and ease it back from the main case to the maximum extent available (about 5 mm).
- (5) The rear edge of either cover can now be lifted and the cover withdrawn outwards and rearwards.
- (6) To replace the covers reverse the above procedure.

INITIAL FUNCTIONAL CHECK

NOTE: For a battery powered instrument refer to para. 5.7 for the power supply check.

- 5.6
- (1) With the instrument disconnected from the a.c. supply set the meter mechanical zero adjustment.
 - (2) Set the rear BATTERY/MAINS switch to MAINS, connect the power supply and check that the MAINS ON indicator illuminates.
 - (3) Set the POWER switch to ON.
 - (4) Set the FUNCTION switch to AM.
 - (5) Verify that the IN LOCK lamp is flashing.
 - (6) Apply a suitable a.m. signal, within the operating frequency range, to the appropriate input socket.
 - (7) Check that the IN LOCK lamp changes to a steady illumination. If it fails to do so check that:-
 - (a) The input frequency is within the operating range.
 - (b) Input signal amplitude is within the specification range for the input socket in use. Set the Function switch to the LEVEL position to determine whether the amplitude is too high or low, as follows:-
 - (i) Upper limit corresponds to approximately 8 on the meter 10 scale.
 - (ii) Lower limit corresponds to approximately 2 on the meter 10 scale.
 - (c) Modulation is within the specified range.
 - (8) Verify that the meter reading is correct for the signal applied.
 - (9) Select FM on the FUNCTION switch.
 - (10) Repeat (7) and (8) with an f.m. signal input.

BATTERY CHECK

- 5.7
- (1) If the optional battery pack is fitted, disconnect the a.c. supply and set the BATTERY/MAINS switch to BATTERY. Instructions for fitting the optional battery pack assembly are given on page 5-21.
 - (2) Operate the Check switch on the battery pack and verify that the meter reading is to the right of the battery check symbol on the scale. (Within the green band on models with serial numbers 1701 - 1750).
 - (3) If the batteries have not been in recent use it is recommended that the battery check be repeated after about 5 minutes operation, to ensure that the voltage is being maintained.
 - (4) To re-charge, connect up the a.c. supply and set the POWER switch to OFF/CHARGE. The full charging period is approximately 14 hours. In the interests of long battery life overcharging should be avoided.

REMOTE PROGRAM FACILITIES

- 5.8 Remote program connections are made via the 15-way rear connector PL4. The pin functions are listed in Table 1 and logic data in Tables 2 and 3 on page Tech. Spec. (5). Notes on the various facilities are given after the tables.

Remote/Local Changeover

5.9 Models With Serial Numbers 1751 Onwards

A LOCAL/REMOTE changeover switch is provided on the front panel.

5.10 Models With Serial Numbers 1701 to 1750

To select 'remote' operation a voltage of not less than +10V must be applied to pin 11 of the rear connector PL4; a suitable voltage is provided at pin 12. To revert to full 'local' control a logic '0' (or open circuit) must be applied to all relevant control lines on PL4. The simplest procedure is to remove the 15-way free connector, unless the instrument is receiving d.c. power via this connector.

TABLE 7
LIST OF TEST EQUIPMENT REQUIRED

Item	Description	Requirements	Preferred Type
1	Digital Multimeter	Range 0 to 20V Accuracy better than 0.5%	Racal 9077
2	UHF Signal Generator	Range, 800 MHz to 2 GHz Output, 200 mV r.m.s.	Hewlett Packard HP.8614
3	HF Signal Generator	Range, 300 kHz to 30 MHz Output, 1V r.m.s. max (into 50Ω)	HP.606A or Marconi TF144H/4
4	VHF Signal Generator (AM/FM)	Range, 10 MHz to 500 MHz Output, 1V r.m.s. Low noise specification FM 100 kHz deviation	HP.8640
5	Oscilloscope (including x 10 probe)	Bandwidth d.c. to 15 MHz Sensitivity 10 mV/cm. Dual Trace	Racal 9386
6	Millivoltmeter (True RMS)	Range 50 mV to 2V r.m.s. Input impedance > 100kΩ Freq. range 50 Hz to 1 MHz Accuracy ± 1%	HP.3400A
7	Harmonic Distortion Factor Meter	Range 30 Hz -30 kHz (fundamental) Distortion Level < -55 dB	HP.333A
8	Regulated Power Supply	Range, -30V/0/+30V Rating: 0 to 1A	Farnell L30BT (Twin)
9	Pulse Generator*	Pulse repetition freq: 1 kHz Variable mark/space ratio. Pulse amplitude up to 5V	Lyons Instruments PG22
10	Miscellaneous:-		
	Resistor	56Ω ± 5% 1W	
	Termination	600Ω on BNC plug	
	'T' Piece	BNC (2 female, 1 male)	
	Coaxial leads	BNC to BNC: 1 at 0.5 metre length 2 at 1 metre length	
	Connector, 15 way	For remote control check. Racal Part No. 23-3118	

* The pulse generator is required only for checking the PEAK/MEAN/TROUGH switching

POWER SUPPLY CHECKS

NOTE: It is important that the power supply checks are carried out in the order given, with the initial check being made using a regulated d.c. supply.

AC (Mains) Input Circuit Resistance

- 5.11 (1) DO NOT plug in the mains supply, but check that the mains fuse is fitted.
- (2) Remove the locking plate from the rear panel voltage selector switches S6 and S7.
- (3) Using the multimeter, measure the resistance between the 'Line' and 'Neutral' pins of the rear panel mains connector with switches S6 and S7 in the following positions:-

<u>S6</u>	<u>S7</u>	<u>Resistance Reading</u>
Y	X	$84\Omega \pm 13\Omega$
Y	W	$95\Omega \pm 14\Omega$
Z	X	$275\Omega \pm 41\Omega$
Z	W	$320\Omega \pm 48\Omega$

- (4) Set switches S6 and S7 to the required positions for the local a.c. supply (see page 5-1, Table 6).

Initial Power Supply Check Using DC Supply

NOTE: This check must be carried out if there is any possibility of a fault in the power regulation system.

5.12 Equipment Required

Page 5-5, Table 7

Regulated DC Power Supply
Digital Multimeter
15-way connector (Racal Part No. 23-3118)
56 Ω 1W resistor

Item 8
Item 1

5.13 Procedure

- (1) DO NOT plug in the a.c. supply.
- (2) Set the rear panel BATTERY/MAINS switch to BATTERY and the front panel Power switch to OFF/CHARGE.

- (3) Remove the covers (para. 5.5).
- (4) Connect the external regulated d.c. power supply to the rear panel 15-way connector as follows:-

Pin 12 +13V.
Pin 13 0V (common)
Pin 14 -13V

Set the current trip, or limit, on the external power supply to 1A.

- (5) Set the POWER switch to ON.
- (6) Connect the multimeter to pin 21 of the power supply p.c.b. (19-0806) and verify a reading of -10V ($\pm .05V$). If necessary adjust R19 on the p.c.b. to achieve the required reading.
- (7) Transfer the multimeter to pin 20 and verify a reading of +10V ($\pm 0.4V$).
- (8) Note the current drain at the external power supply, which should be 300 mA \pm 50 mA in each line.
- (9) Increase the external supply voltages to +20V and -20V and re-check the voltages:-

Pin 20 +10V \pm 0.5V
Pin 21 -10V \pm 0.1V
- (10) Connect a 56 Ω 1W resistor between pin 20 and 0V. Verify a current reading of not less than 400 mA on the external supply and check that the external supply voltages are maintaining 20V.
- (11) Repeat test (10) on the negative supply at pin 21 and 0V.
- (12) Set the POWER switch to OFF/CHARGE. Disconnect the power supply and test equipment.

AC (Mains) Charging and Operation

5.14 Equipment Required

Page 5-5, Table 7

Digital multimeter
56Ω 1W Resistor

Item 1

NOTE: If there is any suspicion of a fault in the instrument's power supply circuits, the d.c. supply check (para. 5.13 must be satisfactorily completed before connecting the a.c. mains supply.

5.15 Procedure

- (1) Before connecting the a.c. supply remove the top cover.
- (2) Check that the rear panel voltage selection switches are correctly set (see page 5-1 Table 6).
- (3) Set the front panel POWER switch to OFF/CHARGE and the rear panel BATTERY/MAINS switch to MAINS.
- (4) Connect the a.c. mains supply and check that the MAINS ON lamp illuminates.
- (5) Using the digital multimeter measure the d.c. voltages (relative to chassis) at the following points on the Power Supply Regulator p.c.b. (19-0806):-

Pin 11	+21V ± 2V
Pin 10	-21V ± 2V
Pin 20	+17V ± 1V
Pin 21	-17V ± 1V

NOTE: The voltage on pins 10 and 11 will differ from 21V in proportion to any difference between the a.c. supply voltage and the mid point of the selected operating range. The voltages on Pin 20 and 21 are the charging voltages (off load).

- (6) To check the charging set the multimeter to read 1A d.c. and connect between pin 20 (positive) and 0V. Verify a reading of between 550 mA and 700 mA.
- (7) Transfer the meter connections to read the current between pin 21 (negative) and 0V. Verify a reading of between 550 mA and 700 mA.
- (8) Connect the multimeter and 56Ω resistor in series between pin 20 and 0V. Check that the current is between 155mA and 206mA and that the voltage at pin 20 is between +9.6V and +10.4V.

NOTE: If difficulty is experienced in setting R34, or it is obvious that the loop will not lock, then it will probably be necessary to check each section of the loop. This is facilitated by removing link LK1 (Fig. 6) in the oscillator varactor line, and applying an external voltage (in the range -5V to +5V) to pin 22, which allows the oscillator to be held at any desired frequency within its range. An external signal may now be applied to the input socket and traced through the various circuits of the frequency locking loop, checking for correct operation, as described in Chapter 4, paras. 4.17 to 4.45.

Local Oscillator Alignment and Loop Checks

NOTE All measurements and adjustments are made on the Lock p.c.b.

- 5.18 (1) Carry out the procedure of 5.17 then change the signal generator frequency to 1.480 MHz, $\pm .005$ MHz.
- (2) Screw the adjuster of inductor T1 out (anticlockwise) until the loop just locks and maintains lock for at least 20 seconds. This can be verified by connecting the oscilloscope to TP4 and observing the waveform. There will be signs of instability (frequency jumping) if the loop is not locking correctly. If the IN LOCK indicator is flashing it does not necessarily mean that the loop is out of lock. There could be a fault in the a.g.c. level measuring circuit (para. 5.20) or even the lamp flashing circuits. The stability of the i.f. in the loop (as checked at TP4 in para. 5.17) is the best guide at this stage in deciding whether the i.f. loop is locked.
- (3) With the multimeter check the d.c. voltage at TP5 which should be -5V ± 0.4 V relative to the 0V (common line).
- (4) Set the oscilloscope to 2V/cm (centre zero) and display simultaneously the d.c. voltages on TP5 and TP6. Check that the two traces coincide.
- (5) Watch the oscilloscope while increasing the signal generator frequency to approximately 1.7 MHz. Verify that the two traces on the oscilloscope rise together with no more than 1V difference between them, until, when the signal generator frequency is no longer changing, the two traces again come into alignment within 0.2V of each other. This checks the operation of the fast locking circuits, IC3, IC5, Q29 and Q30.
- (6) Increase the signal generator frequency to 2.3 MHz (approximately) while verifying that the oscilloscope traces behave the same as in (5).
- (7) Slowly increase the signal generator frequency and check that the voltage at TP5 reaches +5.3V, ± 0.5 V, before jumping to between -2V and -4V. This checks the extent of the oscillator frequency range.
- (8) Slowly decrease the signal generator frequency and check that the voltage at TP5 reaches -5.5V, ± 0.5 V, before jumping to not greater than +2V.

Level Indicator Adjustment

5.19 Equipment Required

Page 5-5, Table 7

HF Signal Generator	Item 3
Oscilloscope	Item 5
Digital Multimeter	Item 1
Millivoltmeter	Item 6
Short coaxial lead (0.5m max.)	
600 Ω BNC load.	

5.20 Procedure

NOTE: Tests (1) to (4) check the operation of the a.g.c. levelling circuits (Q40 to Q45 in Fig. 5) and the a.m. detector (Q23 to Q26 in Fig. 3).

- (1) Set the signal generator to deliver 100 mV r.m.s. at 2 MHz into the low-level (100 mV) input of the 9008. Set the PEAK/MEAN/TROUGH switch to PEAK (+).
- (2) Connect the oscilloscope to the IF output on the 9008 rear panel using the short coaxial lead.
- (3) Check that there is no visible distortion of the 430 kHz i.f. waveform.
- (4) Remove the coaxial lead from the oscilloscope, fit a BNC 'T' piece and 600 Ω load, and connect to the input of the millivoltmeter. Record the i.f. voltage, which should be 50 mV \pm 8 mV.

Tests (5) to (8) check the operation of the a.g.c. level circuits (Q40, Q47 to Q50 in Fig. 5) also IC8 and the meter circuit ICI in Fig. 3.

- (5) Increase the input level to 150 mV and adjust R117 on the LOCK p.c.b. until the IN LOCK lamp just commences to flash.
- (6) Reduce the input level to below 1 mV r.m.s. and check the IN LOCK lamp starts to flash. Slowly increase the input level, noting the level at which the lamp just stops flashing. This should be below 4 mV r.m.s.
- (7) Increase the input level to 5mV r.m.s. and check that the IN LOCK lamp remains continuously lit.
- (8) Set the FUNCTION switch to LEVEL. Connect the digital multimeter to monitor the rear panel DC output socket. Verify a reading of 0.25V \pm .05V.
- (9) Disconnect the test equipment.

Sampling Mixer Frequency Response

5.21 Equipment Required

Page 5-5, Table 7

UHF Signal Generator
VHF Signal Generator

Item 2
Item 4

5.22 Procedure

- (1) Connect the appropriate signal generator to the low-level (100 mV) input socket of the 9008.
- (2) Apply the frequencies listed in Table 8 and reduce the input levels to the points at which the IN LOCK lamp just starts to flash (Table 8 middle column).

TABLE 8

Sampling Mixer Response

Input Frequency	Input Level at which IN LOCK Lamp Commences to flash	
	Low Level Socket	High Level Socket
<u>MHz</u>		
50	Less than 4 mV	Less than 27 mV \pm 12 mV
100	Less than 4 mV	Less than 27 mV \pm 12 mV
500	Less than 4 mV	Less than 27 mV \pm 12 mV
800	Less than 8 mV	Less than 120 mV
<u>GHz</u>		
1.0	Less than 8 mV	Less than 120 mV
1.5	Less than 16 mV	Less than 120 mV
2.0	Less than 16 mV	Less than 120 mV

- (3) Transfer the signal generator output to the high-level (1V) input socket of the 9008.
- (4) Repeat operation (2) but refer to the readings in the right-hand column of Table 8.
- (5) Disconnect the test equipment.

MEASURING PCB TESTS

Calibration

5.23 The following tests provide functional checks. For accurate calibration the user is recommended to take advantage of the service available at Racal Dana Instruments Limited.

5.24 Customers are advised not to adjust preset controls on the Measuring p.c.b. unless they are using a calibrated low distortion modulation source which has an accuracy better than 1.5% on modulation depth and peak deviation, and less than 0.3% distortion.

AF Output Levels

5.25 Equipment Required

Page 5-5, Table 7

AM/FM HF Signal Generator (Refer to Para. 5.24)

Oscilloscope

Item 5

Digital Multimeter

Item 1

Millivoltmeter

Item 6

BNC 'T' Piece with 600 Ω load.

5.26 Procedure

- (1) With the power switch set to OFF/CHARGE set the meter mechanical zero.
- (2) Set the 9008 controls:-
 - AF FILTER to IN
 - PEAK/MEAN/TROUGH to PEAK
 - AM/LEVEL/FM to AM
 - LOCAL/REMOTE to LOCAL (if fitted)
 - METER RANGE switches to 1.5/50 and 50
 - POWER switch to ON
- (3) Set the signal generator controls:-
 - Frequency 11.8 MHz, with the output set to deliver 100 mV r.m.s. into the low-level input socket of the 9008.
 - AM mode.
 - Modulation frequency 1 kHz.
 - Modulation depth 50%.
- (4) Connect the signal generator to the low-level (100 mV) input socket of the 9008 and check that the IN LOCK lamp shows steady illumination.
- (5) Using a short coaxial lead connect the rear panel AF output socket to the oscilloscope, and check for a nominal 1 kHz sinewave with no obvious distortion.

- (6) Before making any of the adjustments in the following tests refer to para. 5.24. Disconnect the oscilloscope. Set the digital multimeter to the 10V range and connect to the rear panel DC output socket, using the coaxial lead. Verify a reading of $1V \pm .005V$. If necessary adjust R66 on the Measuring p.c.b. (Fig. 3) to achieve this.
- (7) If necessary, adjust R134 on the Measuring p.c.b. for a reading of 50 (f.s.d.) on the front panel meter.
- (8) Set the PEAK/MEAN/TROUGH switch to TROUGH and if necessary, adjust R120 for the same DC output reading as in (6).
- (9) Change the modulation depth to 5% and set the PEAK/MEAN/TROUGH switch to MEAN.
- (10) Adjust R171 on the Measuring p.c.b. for a reading of $0.1V \pm .001V$ on the digital multimeter at the rear panel DC output socket.
- (11) Return the modulation depth to 50% setting and set the PEAK/MEAN/TROUGH switch to PEAK.
- (12) With the digital multimeter verify a reading of $1V \pm .005V$ at the DC output socket. If necessary adjust R66 for this reading.
- (13) Set the PEAK/MEAN/TROUGH switch to TROUGH and verify $1V \pm .005V$ at the DC output sockets. If necessary adjust R120 for this reading.
- (14) Repeat steps (9) to (13) until the correct figures are obtained in all three positions of the PEAK/MEAN/TROUGH switch.
- (15) Set the PEAK/MEAN/TROUGH switch to MEAN and check for $1V \pm .01V$ at the DC output socket.
- (16) Set the PEAK/MEAN/TROUGH switch to PEAK and the AM/LEVEL/FM switch to FM. Change the signal generator to FM, 50 kHz peak deviation.
- (17) Verify that the DC output reading is the same as in (6). If necessary adjust R54 on the Measuring p.c.b. to achieve this.

- (18) Connect a short coaxial lead between the rear panel AF output socket and the input to the millivoltmeter. Record the millivoltmeter reading which should be $1V \pm 200mV$.
- (19) Using a 'T' piece, load the millivoltmeter input with 600Ω and verify a millivoltmeter reading which is half that recorded in (18) $\pm 25mV$. Disconnect the millivoltmeter and 600Ω load. Maintain signal generator input, but with AM mode selected, for the next test.

Automatic Level Control and AF Filter Check

5.27 Equipment Required

Page 5-5 Table 7

AM/FM HF Signal Generator (Refer to para. 5.24).
 Millivoltmeter.
 BNC 'T' Piece with 600Ω load.

Item 6

5.28 Procedure

- (1) Set the 9008 controls as in para. 5.26 (2).
- (2) Set the signal generator as in para. 5.26 (3) and connect to the low level (100mV) input socket of the 9008. Check that the 9008 meter reads 50 (f.s.d).
- (3) Transfer the input signal to the high level (1V) socket and check that the meter reading does not change by more than 1% of f.s.d.
- (4) Reconnect the input signal to the low-level (100mV) socket.
- (5) Switch the AF FILTER switch to OUT and check that the meter reading does not change by more than 1% of f.s.d.
- (6) Reset the AF FILTER switch to IN. Set the METER RANGE switches to the '1.5-50' position.
- (7) Using coaxial lead connect the millivoltmeter to the AF output socket of the 9008. Fit the 'T' piece and 600Ω load at the millivoltmeter end.
- (8) Refer to Table 9. Apply modulation frequencies and verify satisfactory millivoltmeter readings, using the 1kHz reading as a reference.

TABLE 9
AF Filter Check

Modulation Frequencies	Millivoltmeter Readings
1kHz 48Hz 300Hz 3kHz 10kHz 30kHz	dB reference. Less than (Ref. -15dB). (Ref. -3dB) ± 0.7 dB. (Ref. -3dB) ± 0.7 dB. Less than (Ref. -20dB). Less than (Ref. -34dB).

Range Attenuator Check

5.29 The following tests check the Range attenuator steps by reference to the f.s.d. reading, thus avoiding the requirement for an accurately calibrated modulation source, but it must be appreciated that this procedure is subject to a build-up of tolerances.

5.30 Equipment Required

Page 5-5, Table 7

AM/FM Signal Generator

Item 4

5.31 Procedure

- (1) Set the 9008 controls:-
 AF FILTER to IN.
 PEAK/MEAN/TROUGH to PEAK.
 AM/LEVEL/FM to FM.
 METER RANGE switches to 3-100 and 3.

- (2) Set the signal generator controls:-
 11.8 MHz at 100mV r.m.s. into the low level input socket of the 9008.

FM Mode
 Modulation frequency: 1kHz
 Peak deviation: 3kHz

- (3) On the signal generator adjust the peak deviation to obtain an exact full scale reading of 3 kHz on the meter scale of the 9008.
- (4) Set the METER RANGE lever switch to position '10 kHz' and verify that the meter reading falls to 3 kHz on the 0-10 kHz scale.
- (5) Increase the signal generator peak deviation to obtain a precise full scale reading on the 0-10 kHz scale.
- (6) Set the METER RANGE lever switch to position '30 kHz' and verify that the meter reading falls to '10' kHz on the 0-30 kHz scale.
- (7) Increase peak deviation to obtain a full scale reading on the 0-30 kHz scale. Set the METER RANGE lever switch to position '100 kHz' and verify that the reading falls to 30 kHz on the 0-100 kHz scale.
- (8) Adjust the signal generator peak deviation to give a 50 kHz reading on the 100 kHz range of the 9008.
- (9) Set the Meter Range toggle switch to the '1.5-50' position and verify that the meter reads 50 kHz on the 0-50 kHz scale.

AF Harmonic Distortion

5.32 For this test the user must be certain that the signal generator modulation performance is not inferior to the specification of the 9008, as stated in para. 5.24.

5.33 Equipment Required

AM/FM Low Distortion Signal Generator (see para. 5.24)
Total Harmonic Distortion Meter (Table 7, item 7).

5.34 Procedure

- (1) Set the 9008 controls:-
AM/LEVEL/FM switch to AM.
METER RANGE switches to 3-100 and 100.
AF FILTER switch to OUT.
PEAK/MEAN/TROUGH switch to TROUGH.
- (2) Set the signal generator controls:-
11.8 MHz at 50 mV r.m.s. into the low-level input socket of the 9008.

AM mode.

Modulation frequency: 1 kHz.

Modulation Depth: to be set to 80% reading on the 9008 (see operation (3)).

- (3) Connect the signal generator output to the low level (100 mV) input socket of the 9008 under test, and adjust the signal generator modulation depth control to give a reading of 80% on the 9008 meter.
- (4) Connect the Total Harmonic Distortion meter to the rear panel AF OUTPUT socket. Refer to Table 10, set the modulation frequencies on the signal generator and verify that the total harmonic distortion reading is lower than -46 dB.

TABLE 10

Total Harmonic Distortion (AM)

Modulation Freq. (AM)	Total Harmonic Distortion
48 Hz 1 kHz 10 kHz 30 kHz	Lower than -46 dB

- (5) Set the AM/LEVEL/FM switch to FM.
- (6) Set the signal generator to FM, with 100 kHz peak deviation, and connect to the high level (1V) input socket. Refer to Table 11 below, and check the total harmonic distortion limits for the modulation frequencies listed.

TABLE 11

Total Harmonic Distortion (FM)

Modulation Freq. (FM)	Total Harmonic Distortion
48 Hz	- 50 dB
1 kHz	- 50 dB
3 kHz	- 50 dB
10 kHz	- 47 dB
30 kHz	- 47 dB

- (7) Disconnect the Distortion Meter but retain the signal generator for the next check.

AF Frequency Response

5.35 Equipment Required

AM/FM Calibrated Signal Source with flat frequency response (refer to para. 5.24).
Digital Voltmeter (DVM) (Table 7, item 1).

5.36 Procedure

- (1) Set the 9008 controls:-
AM/LEVEL/FM to FM
PEAK/MEAN/TROUGH to PEAK.
AF FILTER to OUT.
METER RANGE switches to 3-100 and 100.
- (2) Set the signal generator controls to FM mode, 100 kHz peak deviation, 11.8 MHz at 100 mV r.m.s. into the low level socket of the 9008.
- (3) Connect the d.v.m. to the rear panel DC output socket. Refer to Table 12 and apply the listed modulation frequencies. Check the variations in d.v.m. readings, using the reading at 1 kHz as a reference.

TABLE 12

AF Frequency Response

Modulation Frequency.	DVM Reading
1 kHz	Reference (approximately 1V)
43 Hz	Reference \pm .03V
300 Hz	Reference \pm .01V
3 kHz	Reference \pm .01V
10 kHz	Reference \pm .03V
30 kHz	Reference \pm .05V

- (4) Set the 9008 AM/LEVEL/FM switch to AM.
- (5) Set the signal generator to AM with 80% modulation depth.

(6) Repeat the operations of Table 12.

(7) Disconnect the test equipment.

REMOTE CONTROL CHECK

5.37 Equipment Required

Page 5-5, Table 7

AM/FM Signal Generator

Item 3

Digital Multimeter

Item 1

Connector (socket, free, 15-way, Racal Part No. 23-3118)

5.38 Procedure

(1) Prepare a 15-way connector with the following facilities and connect to the rear panel connector PL4:-

Pin 1	+5V	Pin 8	Flying lead
Pin 2	+5V	Pin 9	Flying lead
Pin 3	+5V	Pin 10	Flying lead
Pin 4	+5V	Pin 11	*See NOTE
Pin 5	+5V	Pin 12	No connection
Pin 6	+5V	Pin 13	0V (common)
Pin 7	+5V	Pin 14	No connection
		Pin 15	Flying lead

(2) Set the LOCAL/REMOTE switch to REMOTE (if fitted).

(3) Set the signal generator to:-
11.8 MHz at 100 mV r.m.s. into the low-level input socket of the 9008.
AM mode.
Modulation frequency: 10 kHz.
Modulation depth: 95%.

(4) Verify that the 9008 meter reads 0.86 (± 0.15) on the 10 scale.

*NOTE: Pin 11 requires no external connection, except in models which are not fitted with LOCAL/REMOTE switch. In these models a voltage of not less than +10V must be connected to pin 11 to obtain remote control. Pin 12 provides a suitable voltage for this purpose.

- (5) Verify that the 'local' switches are disabled by operating the following controls and checking that the meter reading does not change:-
 PEAK/MEAN/TROUGH.
 AM and FM (not LEVEL).
 AF FILTER IN and OUT.
 METER RANGE switches from 1.5 to 100.
- (6) Change the modulation frequency to 1 kHz and check that the meter now reads 9.5 (± 0.3).
- (7) Connect the flying lead on pin 15 to 0V and check that the meter reading falls to zero (this checks the 'Battery Check' muting system).
- (8) Connect the flying lead of pin 10 to +5V and verify that the meter reads 3.3 (± 0.3) on the 10 scale. This checks the battery voltage check system..
- (9) Disconnect the flying lead connections of pin 15 and pin 10.
- (10) Connect the flying lead of pin 8 to a digital voltmeter and verify a reading of 0.95V (± 0.01 V). This checks the measurement d.c. output.
- (11) Check that the IN LOCK lamp is showing a steady illumination, then connect the flying lead of pin 9 to the digital voltmeter and verify a reading of +4.7V. (± 0.3 V). This checks the 'in-lock' signal output.
- (12) Disconnect the signal generator from the 9008 input and check that the voltage on flying lead pin 9 falls to 0V (± 0.3 V). The 9008 IN LOCK lamp should be flashing.
- (13) Disconnect the test equipment and rear panel 15-way connector.

BATTERY PACK FITTING INSTRUCTIONS

Items Supplied

- 5.39 (1) Optional Battery Pack Kit (Part No. 11-1148).
- (2) 27 k Ω resistor. (20-2273)

Fitting Procedure

- 5.40 (1) Fit the battery pack externally to the bottom cover of the instrument as follows. If fitting to instruments with serial numbers 1701 to 1750 inclusive, the modification to R170 (see para.5.41) must be carried out first.

- (2) Switch off and disconnect the a.c. power supply.
- (3) Place the instrument on the bench with bottom cover uppermost.
- (4) Remove the caps from the four plastic feet on the bottom cover of the instrument, then, using a Pozidriv screwdriver, unscrew and discard the four feet.
- (5) Remove the cover from the battery pack by removing 4 screws, and the nut and decorative washer from the toggle switch. Take care not to short-circuit the batteries, which may be charged.
- (6) Remove the four M4 nuts securing the pillars to the battery pack chassis, and discard these nuts.
- (7) Place the battery pack chassis on the bottom cover of the instrument with batteries uppermost and the switch facing to the front of the unit.
- (8) Align the holes in the battery pack chassis with the four holes in the instrument cover and screw the pillars (with M4 plain and crinkle washers) through the chassis holes into the bottom cover, thus securing the battery pack to the cover.
- (9) Fit the battery pack cover by passing the hole in the front of the cover over the toggle switch and then fit the M3 screws, with crinkle washers, into the four pillars and make secure.
- (10) Refit the decorative washer and nut on to the toggle switch and lightly tighten.
- (11) Plug the battery pack lead into the 15-way rear panel connector of the 9008.
- (12) Set the rear panel BATTERY/MAINS switch to BATTERY and check the instrument on battery power. Charge the batteries if necessary.
- (13) Carry out the front panel meter calibration procedure, as instructed in paragraph 5.26(1) to (7). Note that R66 should not require adjustment.

RESISTOR CHANGE FOR SERIAL NUMBERS 1701 to 1750

5.41 9008 units with serial numbers 1701 to 1750, which have not previously been fitted with a battery pack option, may require a change in the value of R170 on the Measuring Circuit p.c.b. 19-0804. The value of this resistor should be 27 k Ω . Inspect, and, if necessary, remove the existing resistor and fit the 27 k Ω resistor supplied with the kit.

REMOVAL OF FRONT PANEL

- 5.42 (1) Remove the covers (para. 5.5).
- (2) Remove the carrying handle as follows:-
- (a) Insert a suitable tool such as a flat bladed screwdriver into the slot in the boss of each carrying handle and prise off the cap, thus exposing the retaining screw
 - (b) Extract the screws which hold the carrying handle to the main frame and remove the handle.
- (3) With the handle removed slide back the short length of coloured metal strip into the space normally occupied by the handle boss. This will allow access to the screws which secure the front panel to the main frame. Remove these screws.
- (4) Remove the screws securing Sampler Board (19-0803) to centre screen.
- (5) The front panel assembly can now be carefully withdrawn as far as the wiring permits.
- (6) For further removal, disconnect the interconnecting wiring.

REMOVAL OF REAR PANEL

- 5.43 (1) Completely remove the two screws which are referred to in cover removal (para. 5.5).
- (2) Remove the covers and withdraw the rear panel as far as the wiring permits.
- (3) Unsolder the connections for complete removal of the panel.

MEASURING CIRCUIT PCB 19-0804
(FIG. 2 AND FIG. 3)

SAMPLER PCB 19-0803 (FIG. 1)

METER

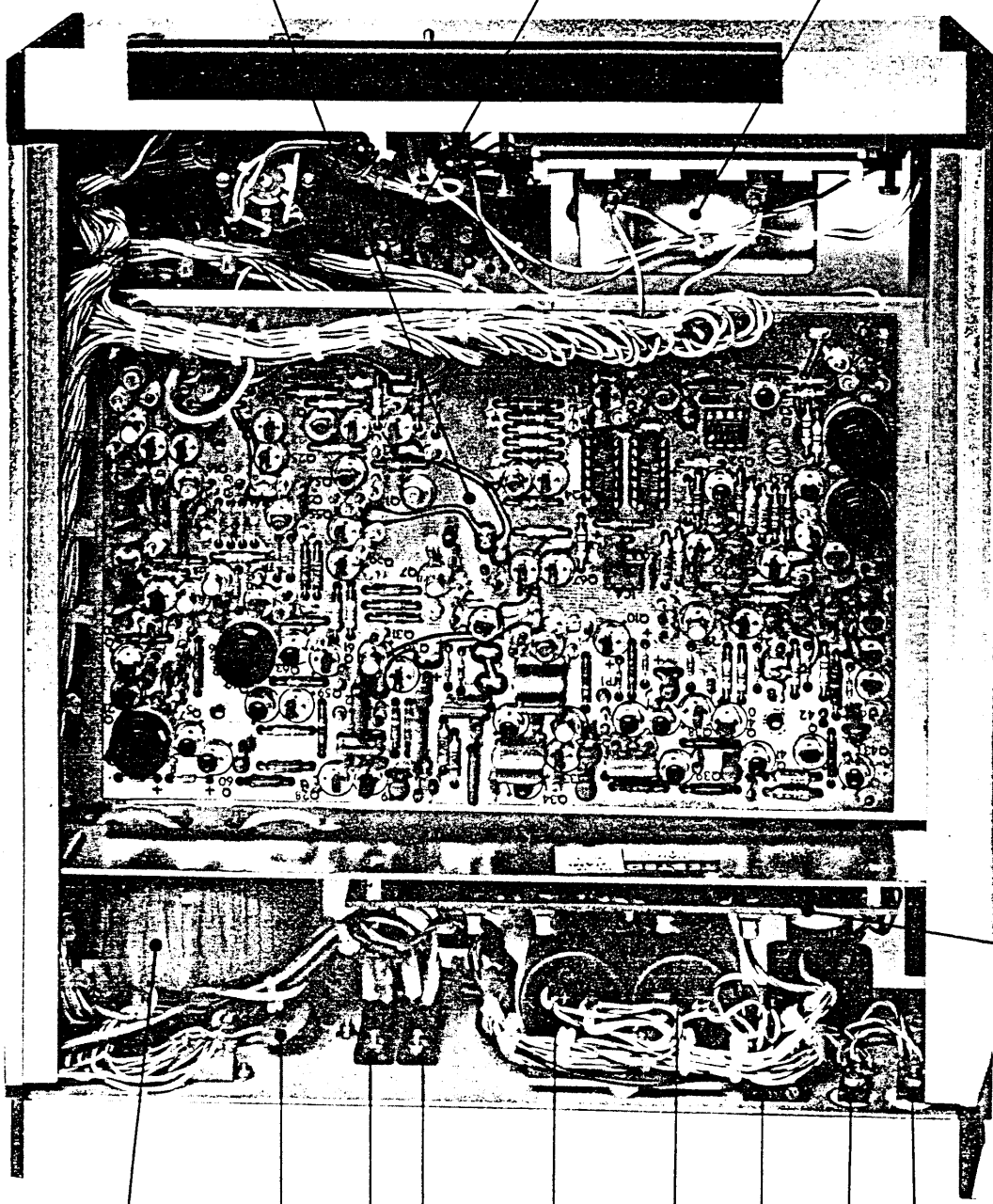

POWER SUPPLY
PCB 19-0806
(FIG. 7 & FIG. 8)

C1 S7 S6 C8 C7 D10 Q15 Q14
(FIG. 9)

FIG. 8

MAINS
TRANSFORMER
T1

WOH 6175
A

9008 Chassis Layout
Topside

Fig. 5.1

SAMPLER PCB 19-0803
(FIG. 1)

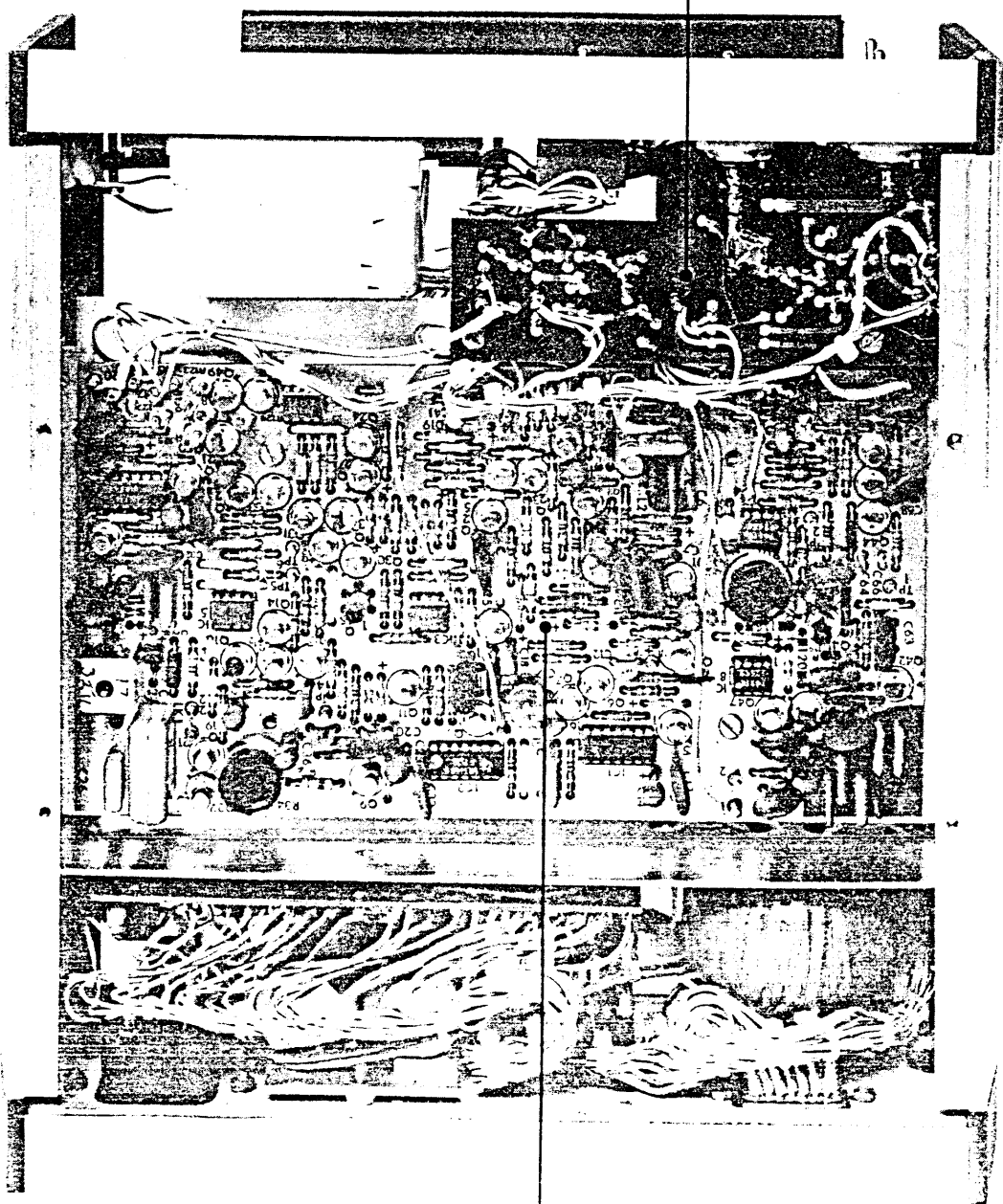

LOCK PCB 19-0805
(FIGS, 4, 5 AND 6)

WOH 6175
A

9008 Chassis Layout
Underside

Fig. 5. 2

SECTION 3

PARTS LISTS

CIRCUIT DIAGRAMS

AND

COMPONENT LAYOUTS

ORDERING OF SPARE PARTS

To be assured of satisfactory service when ordering replacement parts, the customer is requested to include the following information :

- (a) Instrument type and serial number.
- (b) The type reference of the Assembly in which the particular item is located (for example, '19-0834').
- (c) The Racal-Dana Part number and circuit reference of each item being ordered.

It should be noted that a minimum charge of £10 sterling is applicable to all UK orders.

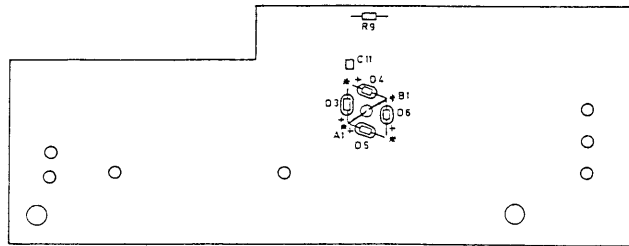

VIEW ON TRACKSIDE

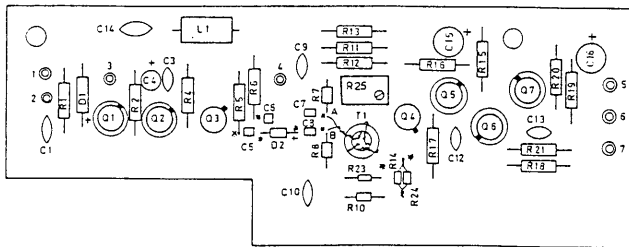

VIEW ON COMPONENT SIDE

1-9 TO 3 MHz INPUT
FROM OSC. DIVIDER
ON 19-0805
(PINS 20/19)

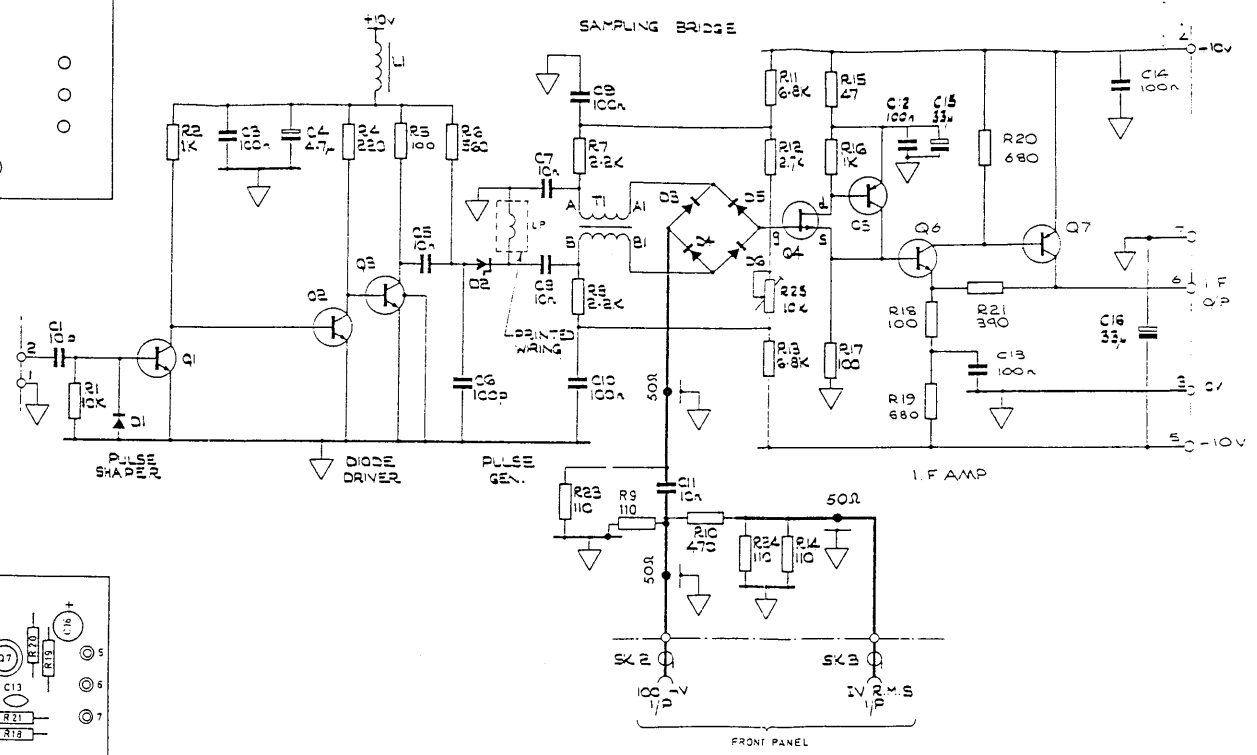

WOH 6175 19-0803
1 2 3 4 6 7 8

Circuit And Layout
Sampler Assembly 19-0803 Fig. 1

PARTS LIST FOR FIG. 1

SAMPLER ASSEMBLY 19-0803

Part No.	Description	Rated	Tol. %	Value	Component Reference
<u>Resistors</u>					
		<u>W</u>		<u>Ω</u>	
20-1363	Carbon Film	1/10	5	110	R9, 14, 23, 24
20-1364	Carbon Film	1/10	5	470	R10
20-1528	Carbon Film	1/10	5	2.2k	R7, 8
20-2101	Carbon Film	$\frac{1}{4}$	5	100	R5, 17, 18
20-2102	Carbon Film	$\frac{1}{4}$	5	1k	R2, 16
20-2103	Carbon Film	$\frac{1}{4}$	5	10k	R1
20-2681	Carbon Film	$\frac{1}{4}$	5	680	R19
20-2391	Carbon Film	$\frac{1}{4}$	5	390	R21
20-2470	Carbon Film	$\frac{1}{4}$	5	47	R15
20-2561	Carbon Film	$\frac{1}{4}$	5	560	R6
20-2272	Carbon Film	$\frac{1}{4}$	5	2.7k	R12
20-2681	Carbon Film	$\frac{1}{4}$	5	680	R20
20-2682	Carbon Film	$\frac{1}{4}$	5	6.8k	R11, 13
20-3221	Metal Oxide	$\frac{1}{2}$	5	220	R4
20-7046	Variable			10k	R25
<u>Capacitors</u>					
		<u>V</u>		<u>F</u>	
21-0693	Electrolytic	25		33μ	C15, 16
21-1006	Tantalum	35	20	4.7μ	C4
21-1508	Ceramic	500	10	10p	C1
21-1616	Ceramic	12	+80-20	100n	C3, 9, 10, 12, 13, 14
21-1711	Ceramic	100	20	100p	C6
21-1719	Ceramic	100	10	10n	C5, 7, 8, 11
<u>Diodes</u>					
22-1029	Silicon, general purpose (1N4149)				D1
22-1033	Hot Carrier, (HP5082-2811)				D3, 4, 5, 6
22-1074	Step Recovery, (5082.0151)				D2
<u>Transistors</u>					
22-6017	Silicon, npn (2N2369)				Q1, 2, 6
22-6186	Silicon, npn (BFY90)				Q3
22-6110	Silicon, pnp (BFX48)				Q5, 7
22-6101	FET, N-channel (W300A)				Q4
<u>Inductors</u>					
17-3209	Transformer (Racal)				T1
17-3166	Choke (Racal)				L1

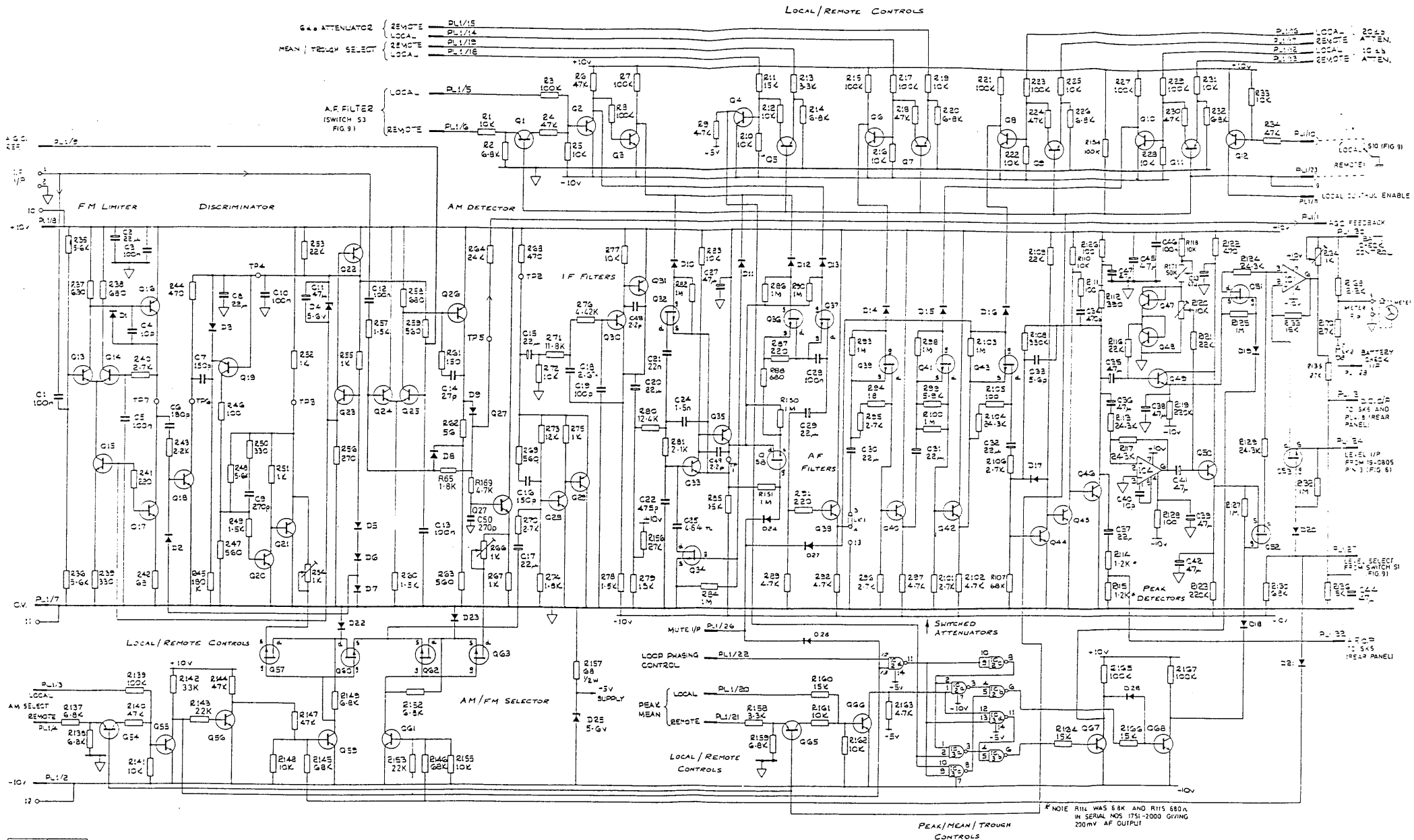

Circuit: Measuring Circuit Assembly 19-0804 Fig 3

PARTS LIST FOR FIG. 3

MEASURING CIRCUIT ASSEMBLY 19-0804

Part No.	Description	Rat.	Tol. %	Value	Component Reference	Part No.	Description	Rat.	Tol. %	Value	Component Reference
	<u>Resistors</u>	<u>W</u>		<u>Ω</u>			<u>Resistors</u>			<u>Ω</u>	
20-2101	Carbon Film	$\frac{1}{4}$	5	100	R46, 105, 111, 126, 128	20-3680	Metal Oxide	$\frac{1}{2}$	5	68	R157
20-2102	Carbon Film	$\frac{1}{4}$	5	1k	R51, 52, 55, 67, 75	20-4008	Metal Oxide	$\frac{1}{4}$	2	1.8k	R65
20-2103	Carbon Film	$\frac{1}{4}$	5	10k	R1, 5, 10, 12, 16, 19, 22, 25, 28, 31, 33, 72, 77, 83, 110, 118, 141, 148, 155, 161, 162	20-4010	Metal Oxide	$\frac{1}{4}$	2	1.5k	R57
20-2104	Carbon Film	$\frac{1}{4}$	5	100k	R3, 7, 8, 15, 17, 21, 23, 27, 29, 139, 154, 165, 167	20-4017	Metal Oxide	$\frac{1}{4}$	2	2.7k	R70
20-2105	Carbon Film	$\frac{1}{4}$	5	1M	R82, 84, 86, 90, 93, 98, 100, 103, 125, 127, 132, 150, 151	20-4024	Metal Oxide	$\frac{1}{4}$	2	1.2k *	R114, 115
20-2151	Carbon Film	$\frac{1}{4}$	5	150	R61	20-4067	Metal Oxide	$\frac{1}{4}$	2	12k	R73
20-2152	Carbon Film	$\frac{1}{4}$	5	1.5k	R49, 60, 78, 85	20-4077	Metal Oxide	$\frac{1}{4}$	2	5.6k	R35, 36, 48
20-2153	Carbon Film	$\frac{1}{4}$	5	15k	R11, 79, 133, 136, 160, 164, 166	20-4101	Metal Oxide	$\frac{1}{4}$	2	24k	R64
20-2180	Carbon Film	$\frac{1}{4}$	5	18	R94	20-4449	Metal Oxide	$\frac{1}{2}$	2	330k	R108
20-2182	Carbon Film	$\frac{1}{4}$	5	1.8k	R74	20-4868	Metal Film	50ppm	0.25	2.7k	R95, 96, 101, 106
20-2184	Carbon Film	$\frac{1}{4}$	5	180k	R45	20-4875	Metal Film	50ppm	0.25	5.9k	R99
20-2221	Carbon Film	$\frac{1}{4}$	5	220	R41, 87, 91	20-4876	Metal Film	50ppm	0.25	24.3k	R104, 113, 117, 121, 129
20-2222	Carbon Film	$\frac{1}{4}$	5	2.2k	R43, 168	20-4924	Metal Film	50ppm	0.25	2.1k	R81
20-2223	Carbon Film	$\frac{1}{4}$	5	22k	R53, 109, 116, 121, 143, 153	20-4926	Metal Film	50ppm	0.25	11.8k	R71
20-2224	Carbon Film	$\frac{1}{4}$	5	220k	R119, 123	20-4925	Metal Film	50ppm	0.25	4.42k	R76
20-2271	Carbon Film	$\frac{1}{4}$	5	270	R56	20-7070	Variable	$\frac{1}{4}$	20	1k	R54, 66, 134
20-2272	Carbon Film	$\frac{1}{4}$	5	2.7k	R40	20-7046	Variable	$\frac{1}{4}$	20	10k	R120
20-2273	Carbon Film	$\frac{1}{4}$	5	27k	R135, 156, 170	20-4927	Metal Film	50ppm	0.25	12.4k	R80
20-2331	Carbon Film	$\frac{1}{4}$	5	330	R39, 50	20-7047	Variable			50k	R171
20-2332	Carbon Film	$\frac{1}{4}$	5	3.3k	R13, 158		<u>Capacitors</u>	<u>V</u>		<u>F</u>	
20-2391	Carbon Film	$\frac{1}{4}$	5	390	R112	21-1038	Tantalum	6.3	20	47μ	C11, 35, 36, 41, 44
20-2471	Carbon Film	$\frac{1}{4}$	5	470	R44, 68, 122	21-1039	Tantalum	16	20	22μ	C2, 8, 15, 17, 20, 29, 30, 31, 32, 37
20-2472	Carbon Film	$\frac{1}{4}$	5	4.7k	R9, 89, 92, 97, 102, 163, 169	21-1045	Tantalum	16	20	47μ	C27, 38, 39, 42, 43, 45, 47
20-2473	Carbon Film	$\frac{1}{4}$	5	47k	R4, 6, 18, 24, 30, 34, 140, 144, 147	21-1508	Ceramic	500	10	10p	C4, 40
20-2333	Carbon Film	$\frac{1}{4}$	5	33k	R142	21-1513	Ceramic	500	10	27p	C14
20-2560	Carbon Film	$\frac{1}{4}$	5	56	R62	21-1523	Ceramic	500	10	180p	C6
20-2561	Carbon Film	$\frac{1}{4}$	5	560	R47, 59, 63, 69	21-1525	Ceramic	500	10	270p	C9, 50
20-2680	Carbon Film	$\frac{1}{4}$	5	68	R42	21-1528	Ceramic	500	10	470p	C34
20-2681	Carbon Film	$\frac{1}{4}$	5	680	R37, 38, 58, 88	21-1616	Ceramic	12	-80-20	100n	C1, 3, 5, 10, 12, 13, 46
20-2682	Carbon Film	$\frac{1}{4}$	5	6.8k	R2, 14, 20, 26, 32, 137, 138, 149, 152, 159	21-1672	Ceramic	63	±0.25p	2.2p	C48, 49
20-2683	Carbon Film	$\frac{1}{4}$	5	68k	R107, 130, 145, 146	21-1677	Ceramic	63	±0.25p	5.6p	C33
						21-2800	Silver Mica	350	1	100p	C19
						21-2816	Mica	350	1	150p	C7, 16
						21-2865	Silver Mica	350	1	475p	C22
						21-2917	Silver Mica	350	1	1.5n	C24
						21-2941	Silver Mica	350	1	2.67n	C18,
						21-2964	Silver Mica	350	1	4.64n	C25
						21-4558	Polyester	100	5	100n	C28
						21-5536	Polycarbonate	100	2	22n	C21

* In serial numbers 1751-2000 R114 is 6.8k and R115 68Ω (200mV AF output).

MEASURING CIRCUIT ASSEMBLY 19-0804 (Cont'd)

Description	Rat.	Tol. %	Value	Component Reference	Part No.	Description	Rat.	Tol. %	Value	Component Reference
<u>Diodes</u>					<u>Transistors</u>					
1 7				D26, 28	22-6010	Silicon, pnp (2N4126)				Q19, 21, 29
1 9				D2, 3, 5, 6, 7, 8, 9, 10, 11, 12, 13, 14, 15, 16, 17, 18, 19, 20, 21, 22, 23, 24, 27	22-6017	Silicon, npn (2N2369)				Q15, 17, 23
					22-6041	Silicon, npn (BC.109)				Q4, 13, 14, 18, 20, 24, 25, 27, 28, 30, 33, 38, 40, 42, 44, 45, 46, 47, 48, 49, 50, 66
1 3				D1	22-6110	Silicon, pnp (BFX.48)				Q1, 5, 7, 9, 11, 12, 16, 22, 26, 31, 35, 54, 65
1009		5	5.6	D4, 25	22-6068	Silicon, npn (BC107)				Q2, 3, 6, 8, 10, 55, 56, 59, 61, 67, 68
<u>Integrated Circuits</u>					22-6101	FET, N-channel (W300A)				Q53
4 4				1C2, 3	22-6124	FET, N-channel (E109)				Q32, 34, 36, 37, 39, 41, 43, 51, 52, 57, 58, 60, 62, 63
4 1				1C1	<u>Miscellaneous</u>					
4121				1C4	17-1009	Straight header, 32-way Free connector for PL1				PL1

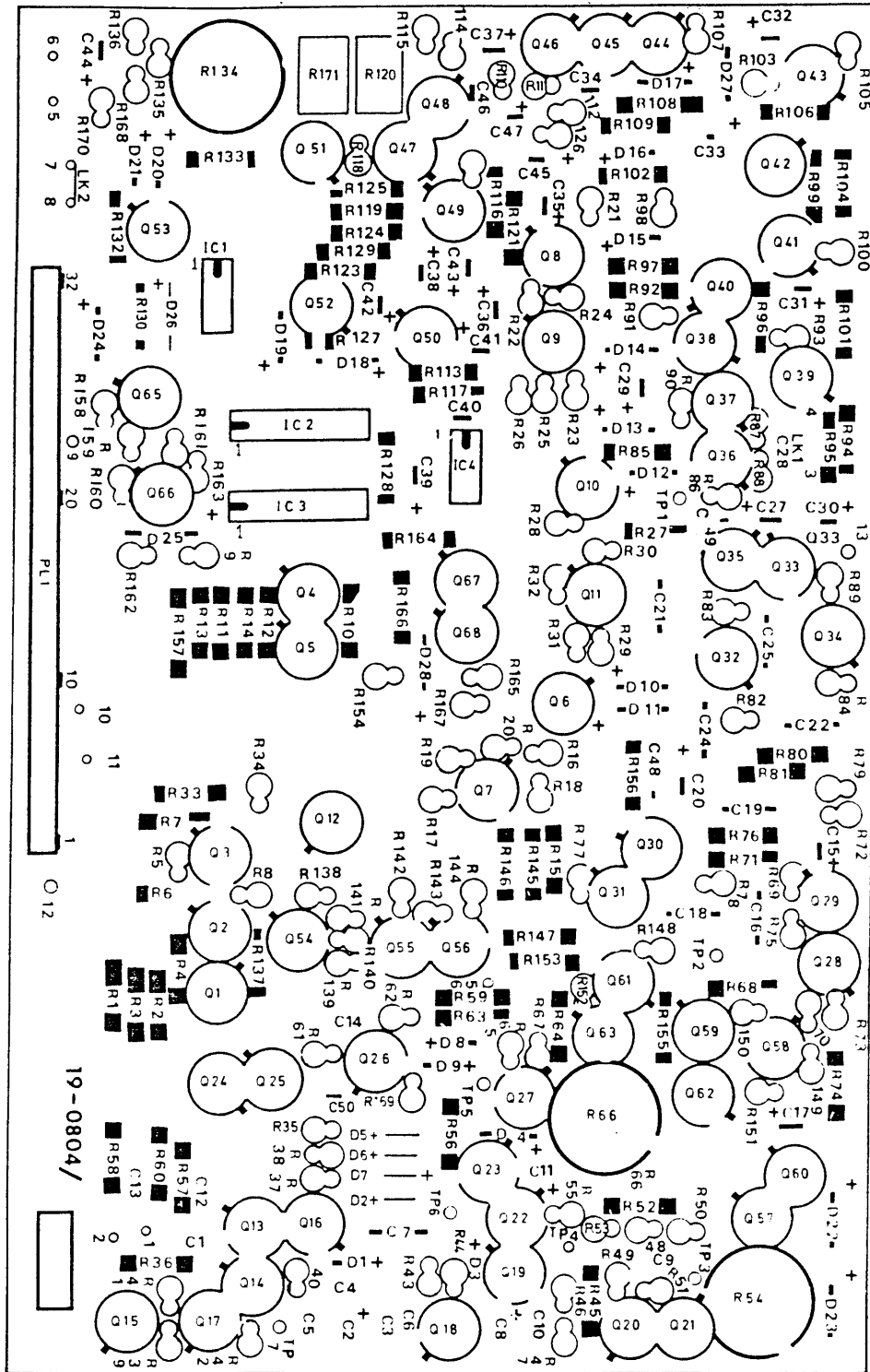

Component Layout : Measuring
Circuit PCB 19-0804

Fig. 2

WOH	6175	14-0804/4
3	4	5
6	7	8

THIS PAGE INTENTIONALLY
LEFT BLANK

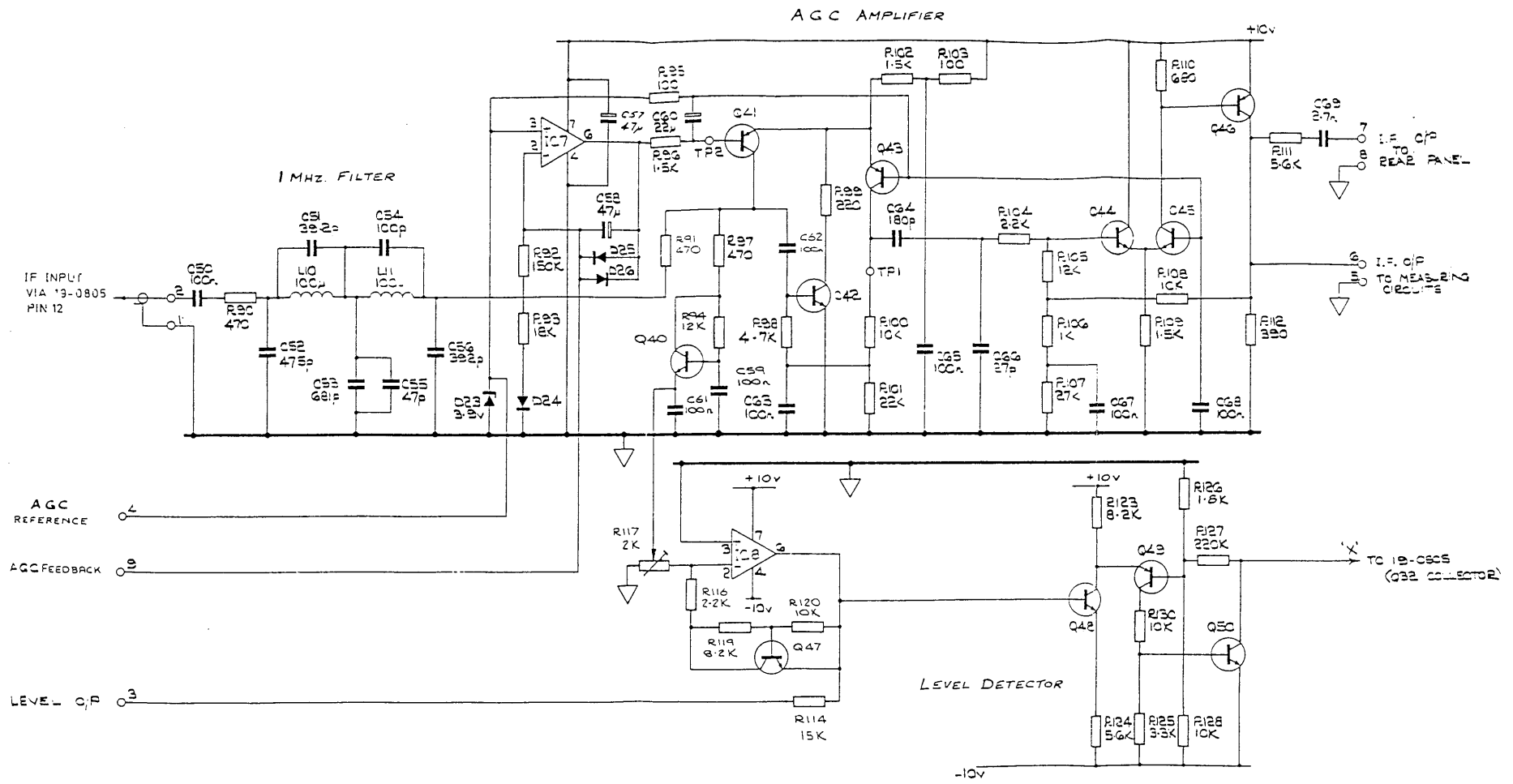

Circuit : Lock PCB
 Assembly 19-0805 (Part 1) Fig. 5

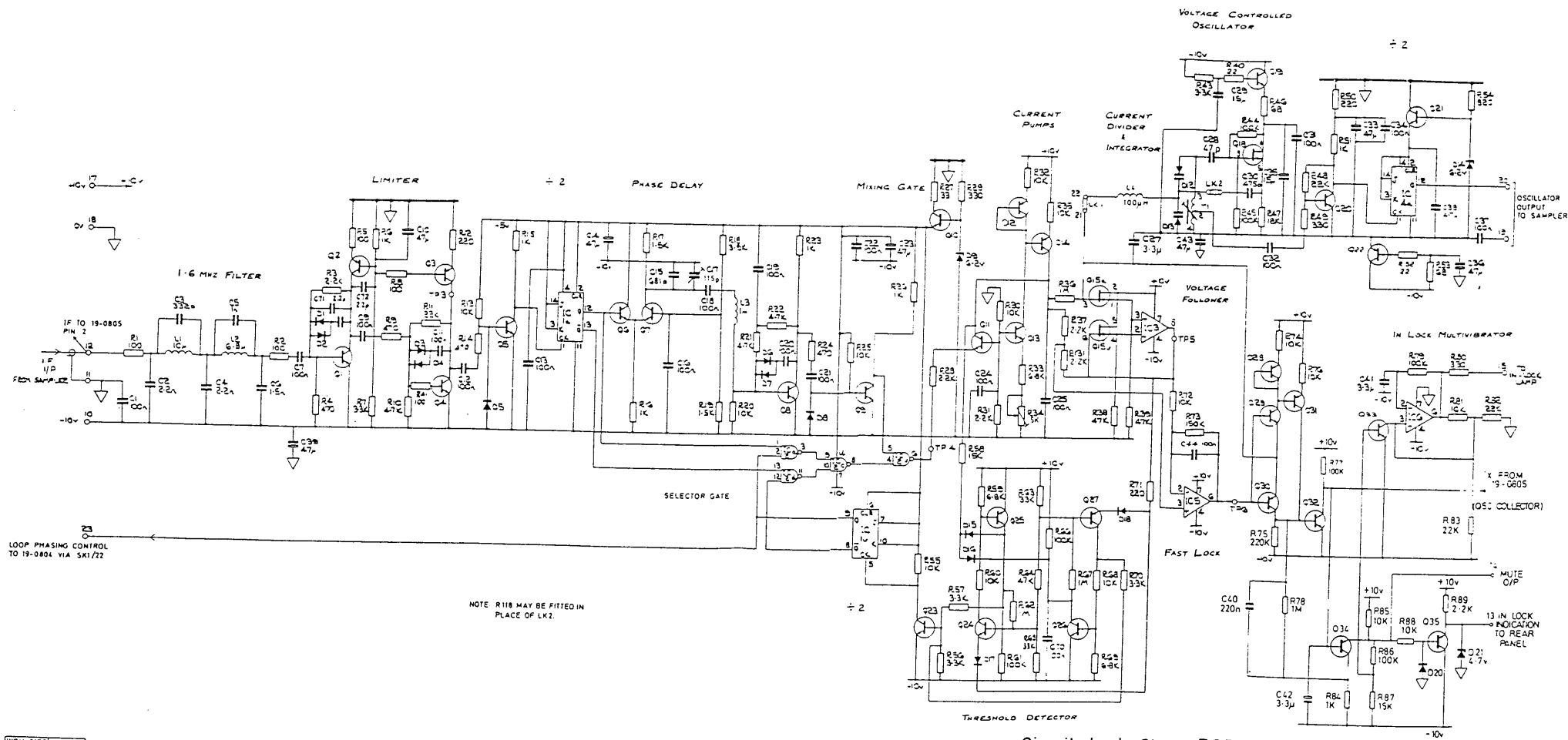

WDM 6175 19-0805
21316167WQH

Circuit: Lock Circuit PCB Assembly
19-0805 (Part 2)

Fig 6

PARTS LIST FOR FIGS. 5 & 6

LOCK ASSEMBLY 19-0805

Description	Rat.	Tol. %	Value	Component Reference	Part No.	Description	Rat.	Tol. %	Value	Component Reference	
<u>Resistors</u>					<u>Capacitors</u>						
			<u>W</u>	<u>Ω</u>				<u>V</u>	<u>F</u>		
2101	Carbon Film	1/4	5	100	R1, 2, 5, 8, 41, 95, 103	21-1000	Tantalum	35	20	3.3μ	C41, 42
2102	Carbon Film	1/4	5	1k	R6, 15, 16, 23, 26, 51, 84, 106	21-1003	Tantalum	20	20	15μ	C29, 35,
2103	Carbon Film	1/4	5	10k	R13, 20, 25, 30, 32, 35, 55, 60, 68, 72, 74, 76, 81, 85, 88, 120, 128, 130	21-1006	Tantalum	35	20	4.7μ	C38,
2104	Carbon Film	1/4	5	100k	R44, 45, 61, 66, 77, 79, 86	21-1039	Tantalum	16	20	22μ	C60
2105	Carbon Film	1/4	5	1M	R36, 62, 67, 78	21-0596	Electrolytic	16	20	47μ	C10, 14, 23, 33, 36, 39, 43, 57, 58
2123	Carbon Film	1/4	5	12k	R94	21-1516	Ceramic	500	10	47p	C55
2152	Carbon Film	1/4	5	1.5k	R17, 19, 96, 102, 109	21-1534	Ceramic	500	10	1.5n	C6
2153	Carbon Film	1/4	5	15k	R58, 87, 114	21-1537	Ceramic	500	20	2.7n	C69
2154	Carbon Film	1/4	5	150k	R73	21-1551	Ceramic	30	+80-20	100n	C25
2182	Carbon Film	1/4	5	1.8k	R126	21-1616	Ceramic	12	+80-20	100n	C1, 7, 8, 9, 11, 12, 13, 16, 18, 19, 20, 21, 22, 24, 31, 32, 34, 37, 44, 50, 59, 61, 62, 63, 65, 67, 68
2183	Carbon Film	1/4	5	18k	R47, 93	21-1643	Ceramic	500	10	2.2n	C2, 4
2220	Carbon Film	1/4	5	22	R40, 52	21-1685	Ceramic	63	2	27p	C66
2221	Carbon Film	1/4	5	220	R12, 50, 71, 99	21-1695	Ceramic	63	2	180p	C64
2222	Carbon Film	1/4	5	2.2k	R3, 28, 31, 37, 89, 116, 131	21-2757	Silver Mica	350	1	39.2p	C51
2223	Carbon Film	1/4	5	22k	R11, 48, 82, 83, 101	21-2800	Silver Mica	350	1	100p	C54
2224	Carbon Film	1/4	5	220k	R75, 127	21-2850	Silver Mica	350	1	332p	C3
2273	Carbon Film	1/4	5	27k	R107	21-2857	Silver Mica	350	1	392p	C56
2331	Carbon Film	1/4	5	330	R29, 49, 80	21-2865	Silver Mica	350	1	475p	C30, 52
2332	Carbon Film	1/4	5	3.3k	R7, 43, 56, 57, 70, 125	21-2880	Silver Mica	350	1	681p	C15, 53
2333	Carbon Film	1/4	5	33k	R63, 65	21-2896	Silver Mica	350	1	1n	C5
2391	Carbon Film	1/4	5	390	R112, 118	21-2641	Silver Mica	350	2	47p	C28
2392	Carbon Film	1/4	5	3.9k	R18	21-4559	Polyester	100	10	3.3μ	C27
2471	Carbon Film	1/4	5	470	R4, 9, 14, 24, 97	21-6033	Trimmer, polycarbonate			115p	C17
2472	Carbon Film	1/4	5	4.7k	R10, 21, 22, 98	21-1589	Ceramic	12	+80-20	220n	C40
2473	Carbon Film	1/4	5	47k	R38, 39, 64,	21-1708	Ceramic	50	20	100n	C70
2562	Carbon Film	1/4	5	5.6k	R111, 124	21-1672	Ceramic	63	0.25p	2.2p	C71, 72
2680	Carbon Film	1/4	5	68	R46, 53	<u>Diodes</u>					
2681	Carbon Film	1/4	5	680	R110	22-1029	Silicon, general purpose (1N4149)				D1, 2, 3, 4, 5, 6, 7, 8, 15, 16, 17, 19, 20, 24, 25, 26
2682	Carbon Film	1/4	5	6.8k	R33, 59, 69	22-1062	Varactor, hyper abrupt (DK65248)				D12, 13
2821	Carbon Film	1/4	5	820	R54	22-1805	Voltage reg.	3.9	5		D23
2822	Carbon Film	1/4	5	8.2k	R119, 123	22-1807	Voltage reg.	4.7	5		D21
3330	Metal Oxide	1/2	5	33	R27	22-1810	Voltage reg.	6.2	5		D9, 14
4007	Metal Oxide	1/2	2	2.2k	R104	<u>Transistors</u>					
4018	Metal Oxide	1/4	2	10k	R100, 108	22-6010	Silicon pnp (2N4126)				Q41, 43
4052	Metal Oxide	1/4	1	150k	R92	22-6017	Silicon npn (2N2369)				Q1, 4, 5, 6, 7, 8, 9, 10, 11, 13, 19, 20, 21, 23, 24, 26, 29, 33, 38, 40, 42, 44, 45, 47
4067	Metal Oxide	1/4	2	12k	R105	22-6041	Silicon npn (BC109)				Q2, 3, 12, 14, 25, 27, 28, 30, 31, 34, 35, 45, 49
4084	Metal Oxide	1/2	2	470	R90, 91	22-6110	Silicon pnp (BFX48)				Q32, 50
7044	Variable, linear			5k	R34	22-6101	N channel FET (W300A)				Q18
7045	Variable, linear			2k	R117	22-6125	Dual N channel FET (E412)				Q15
<u>Integrated Circuits</u>						22-6113	Silicon pnp (ZTX550)				Q22
4044	Quad 2 inp NAND gate (7400)				IC2	22-6068	Silicon npn (BC107)				
4047	Dual master/slave J-K bistable				IC1, 4	22-6101	N channel FET (W300A)				
4111	Op. Amp. high performance (741C)				IC3, 5, 6, 7, 8	22-6125	Dual N channel FET (E412)				
<u>Inductors</u>											
3211	Coil Assembly				T1	22-6113	Silicon pnp (ZTX550)				
7013	Choke			6.8μH	L2						
7014	Choke			10μH	L1						
7017	Choke			100μH	L4						
7081	Choke			100μH	L10, 11						
7086	Choke			1mH	L3						

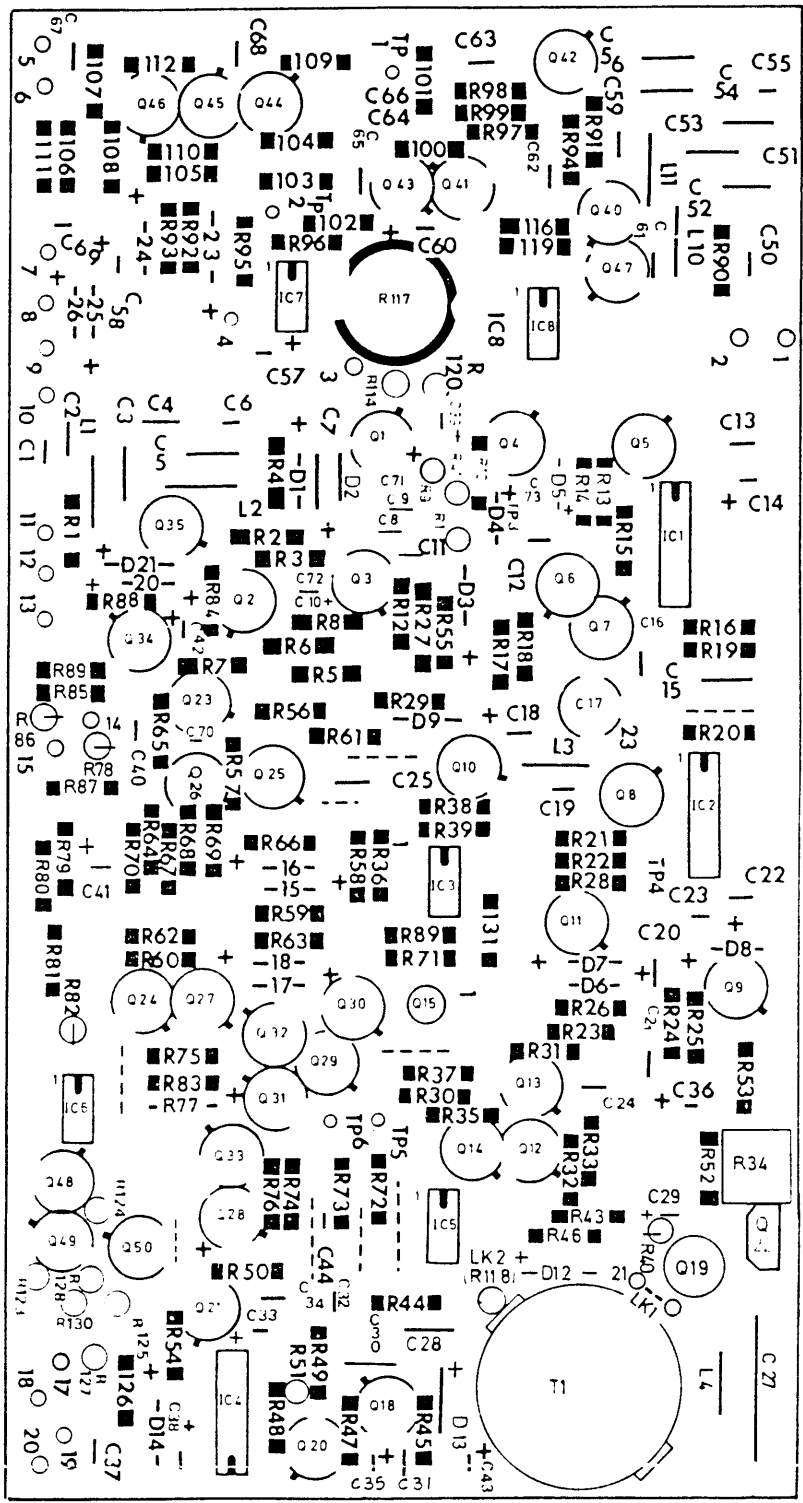

Component Layout :
Lock PCB 19-0805

Fig. 4

W04 194 19 0405
2 3 4 5 6 9 10

THIS PAGE INTENTIONALLY
LEFT BLANK

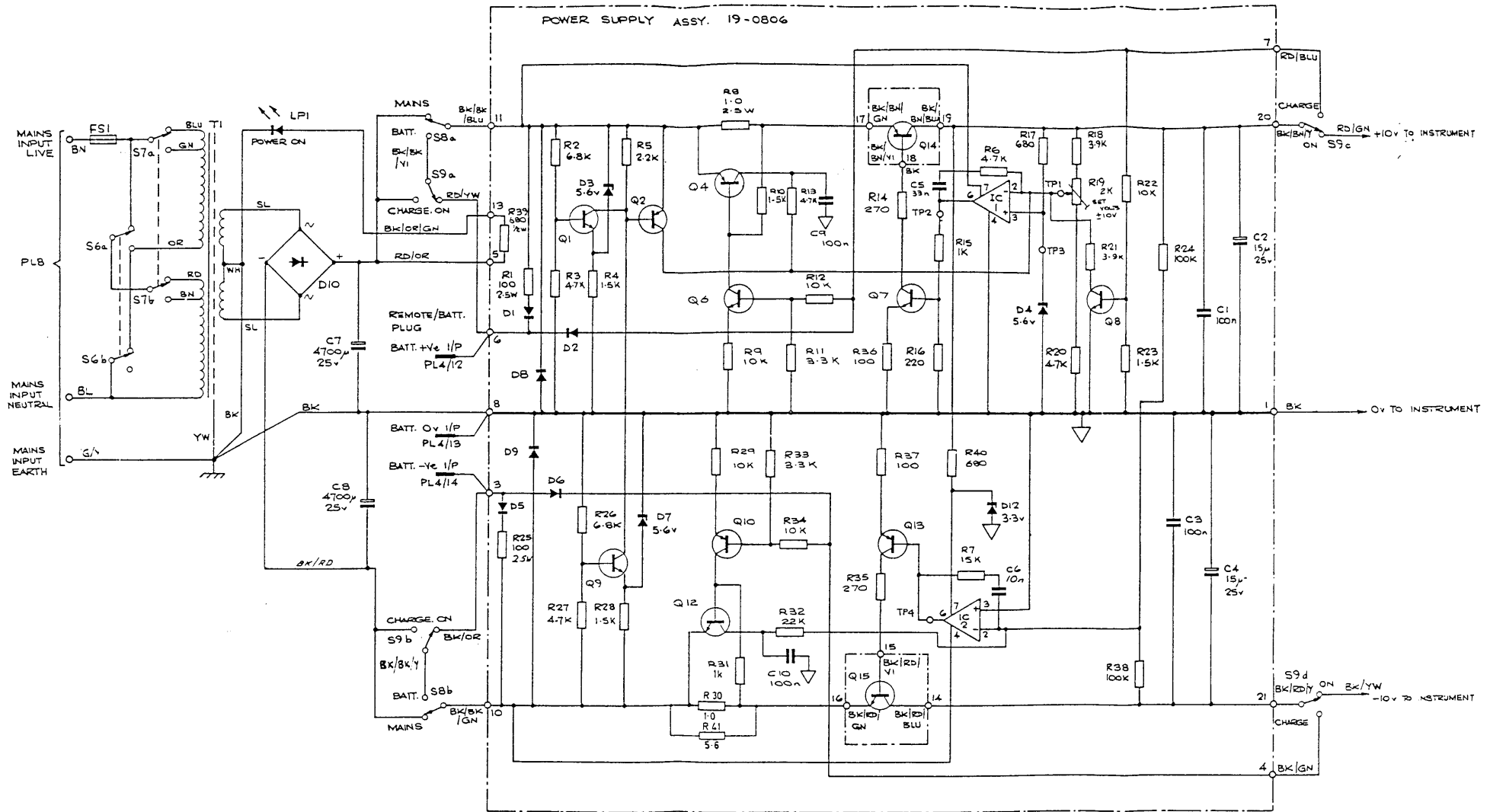

WOM 5175 900877
11-178

Circuit: Power Supply

Fig. 8

PARTS LIST FOR FIG. 8

POWER SUPPLY PCB 19-0806

Part No.	Description	Rat. %	Tol. %	Value	Components Reference
<u>Resistors</u>					
		<u>W</u>		<u>Ω</u>	
20-2101	Carbon Film	1/4	5	100	R36, 37
20-2102	Carbon Film	1/4	5	1k	R15, R31
20-2103	Carbon Film	1/4	5	10k	R9, 12, 22, 29, 34
20-2152	Carbon Film	1/4	5	1.5k	R4, 10, 23, 28
20-2153	Carbon Film	1/4	5	15k	R7
20-2221	Carbon Film	1/4	5	220	R16
20-2223	Carbon Film	1/4	5	22k	R32
20-2222	Carbon Film	1/4	5	2.2k	R5
20-2271	Carbon Film	1/4	5	270	R14, 35
20-2332	Carbon Film	1/4	5	3.3k	R11, 33
20-2392	Carbon Film	1/4	5	3.9k	R18, 21
20-2472	Carbon Film	1/4	5	4.7k	R3, 6, 13, 20, 27
20-2681	Carbon Film	1/4	5	680	R17, 40
20-2682	Carbon Film	1/4	5	6.8k	R2, 26
20-3681	Metal Oxide	1/2	5	680	R39
20-4048	Metal Oxide	1/4	2	100k	R24, 38
20-5026	Wire Wound	2 1/2	10	1.0	R8, 30
20-5060	Wire Wound	2 1/2	5	100	R1, 25
20-5080	Variable, linear	1/4	5	2k	R19
20-2009	Carbon film	1/4	5	5.6	R41
<u>Capacitors</u>					
		<u>V</u>		<u>F</u>	
21-1047	Tantalum	25	20	15μ	C2, 4
21-1545	Ceramic	25	+80-25	10n	C6
21-1547	Ceramic	25	+50-20	33n	C5
21-1551	Ceramic	30	+80-20	100n	C1, 2, 3, 9, 10
<u>Diodes</u>					
22-1602	Silicon (1N4002)				D1, 2, 5, 6, 8, 9
22-1803	Voltage Regulator	3.3V	5		D12
22-1809	Voltage Regulator	5.6V	5		D3, 4, 7
<u>Integrated Circuits</u>					
22-4111	Op. Amp. (741C)				IC1, 2
<u>Transistors</u>					
22-6017	Silicon npn (2N2369)				Q1, 6, 8
22-6038	Silicon pnp (BCY71)				Q2
22-6044	Silicon npn (BFY51)				Q7, 12
22-6110	Silicon pnp (BFX48)				Q10
22-6113	Silicon pnp High Current				Q13
22-6046	Silicon pnp BFX29				Q4
22-6009	Silicon npn ZTX107				Q9

MISCELLANEOUS POWER SUPPLY ITEMS

Part No.	Description	Rat. %	Tol. %	Value	Components Reference
NOTE: The following items are mounted in various parts of the instrument as indicated by headings.					
<u>Rear Screen (11-1053)</u>					
17-4074	Transformer, mains				T1
<u>Rear Panel Assembly (11-1054)</u>					
<u>Capacitors</u>					
21-0540	Electrolytic	25V		4700 μF	C7, 8
<u>Semi-conductors</u>					
22-1650	Rectifier	200V	2A		D10
22-6139	Transistor, power, pnp	25W			C14
22-6081	Transistor, power, npn	25W			Q15
<u>Miscellaneous</u>					
23-3194	Plug, mains				PL3
23-4091	Switches, slide, voltage selection				S6, 7
23-4042	Switch, Battery-mains				S8
23-0029	Fuselink (188V-260V) antisurge	80 mA			FS1
	or				FS1
23-0019	Fuselink (94V-130V) antisurge	160 mA			
23-0044	Fuseholder for FS1				
23-3227	Mains lead assembly				
<u>Front Mounting Panel Assembly (11-1055)</u>					
23-4085	Switch, toggle, Power				S9
26-5003	Indicator, LED, MAINS ON, red				L1

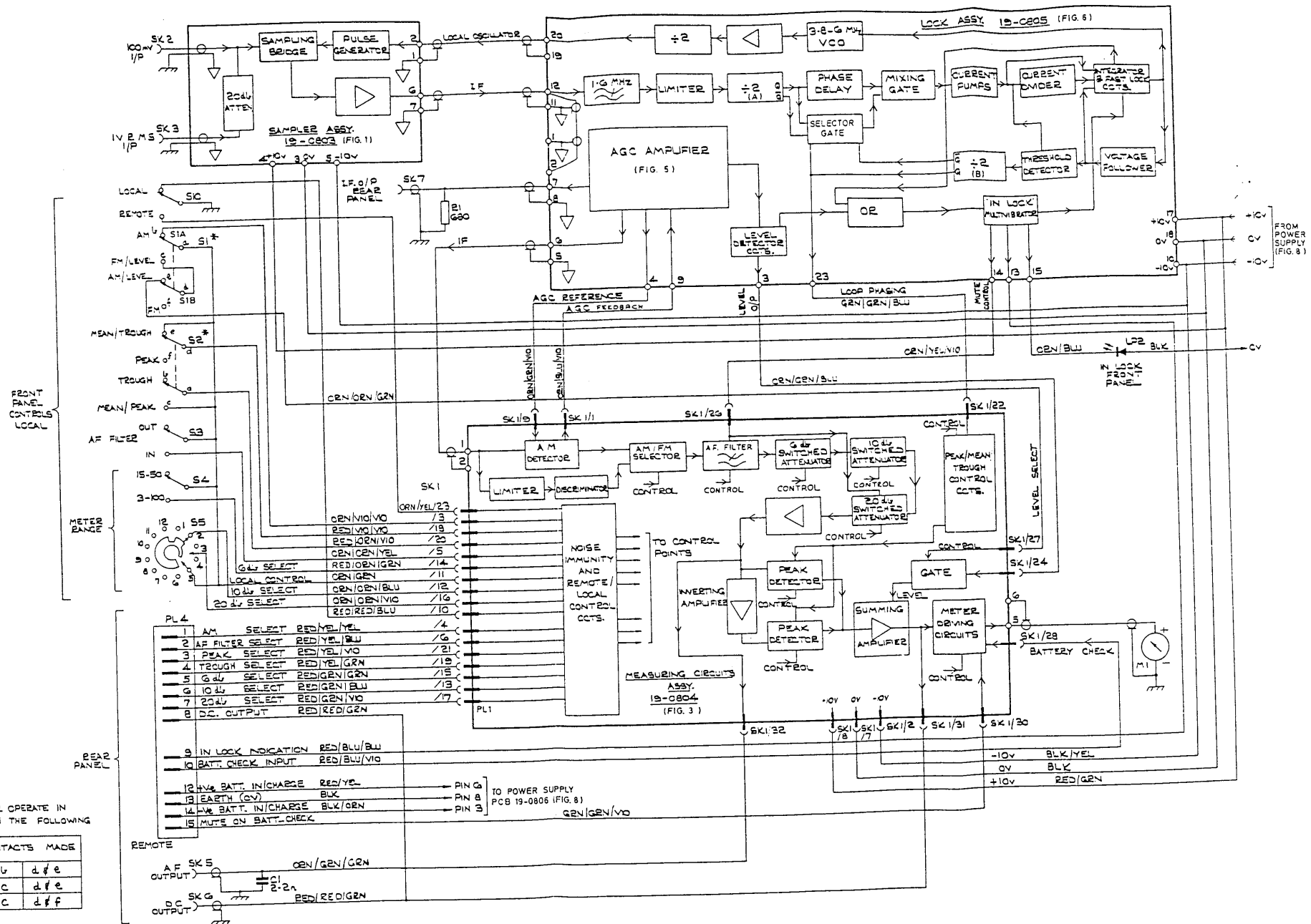

SWITCHES *
 SWITCHES S1/S2 OPERATE IN ACCORDANCE WITH THE FOLLOWING TABLE.

SWITCH POSITION	CONTACTS MADE
1	a # b d # e
2	a # c d # e
3	a # c d # f

Overall Block Diagram 9008

Fig. 9

PARTS LIST FOR FIG. 9

NOTE: The following components list contains miscellaneous items not located on a p.c.b. and not part of the power supply. For the p.c.b. assemblies refer to Parts List 1, 2 and 3. For the power supply refer to Parts List 4.

<u>Part No.</u>	<u>Description</u>	<u>Circuit Ref.</u>
<u>Chassis Assembly (11-1052)</u>		
20-2681	Resistor, carbon film, $\frac{1}{4}$ W 5% 680 Ω	R1
21-1643	Capacitor, ceramic 500V 10% 2.2n	C1
23-5534	Connector, 32-way	SK1
 <u>Rear Panel Assembly (11-1054)</u>		
23-3118	Socket, 15-way, Cinch 43/81/046 (mates with 23-3119)	
23-3119	Plug, 15-way	PL4
23-3120	Shell for 23-3113	
23-3005	Sockets, BNC, bulkhead	SK5, SK6, SK7
23-3019	Plug, free, for 23-3005	
 <u>Front Panel Mounting Assembly (11-1055)</u>		
23-4064	Switches, toggle, on-on-on	S1, S2
23-4065	Switches, toggle, on-on	S3, S4, S10
17-0094	Switch, rotary	S5
23-3204	Sockets, BNC, bulkhead	SK2, SK3
23-3019	Plug, free, for 23-3204	
17-1007	Meter	M1

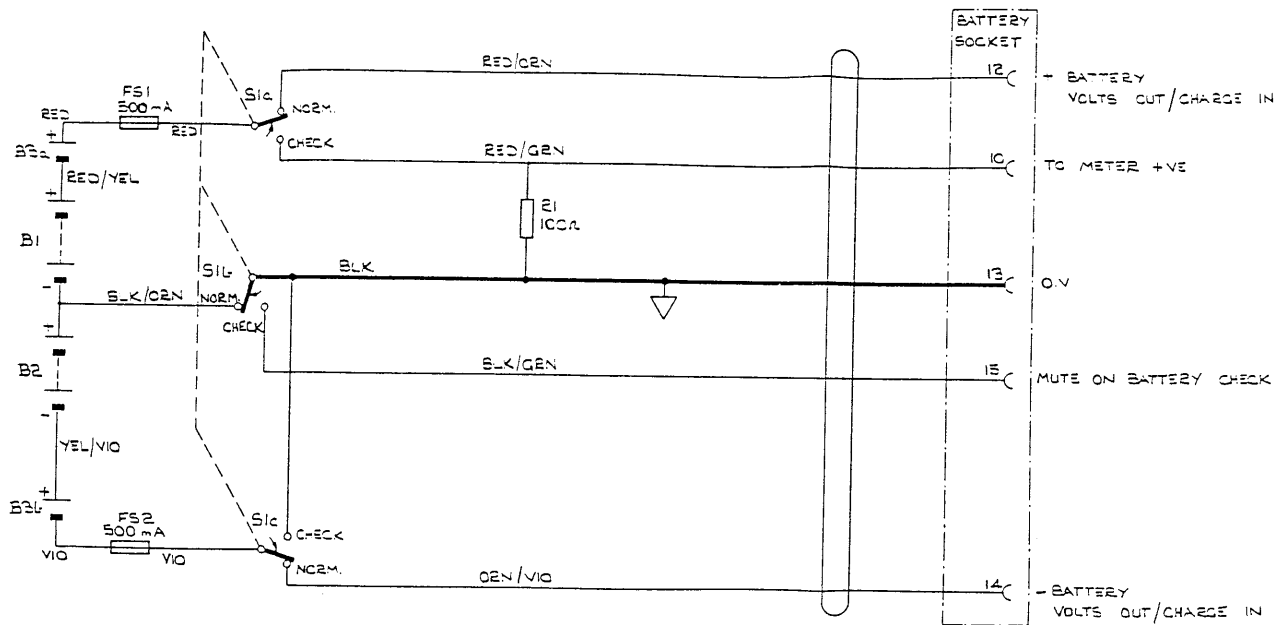

PARTS LIST FOR FIG. 10

BATTERY UNIT CHASSIS ASSEMBLY

(11-1148)

<u>Part No.</u>	<u>Description</u>	<u>Circuit Ref.</u>
20-5062	Resistor, wirewound, 9W 100Ω	R1
23-0004	Fuselink, 500 mA, quick action	FS1, FS2
23-0014	Fuseholder	
23-4083	Switch, 3PDT	S1
23-2511	Battery pack, 3 cells connected	
23-2507	Battery pack, 2 cells not connected, each cell 1.25V 2AH	
23-3118	Socket 15-way	
23-3120	Shell for 23-3118	