

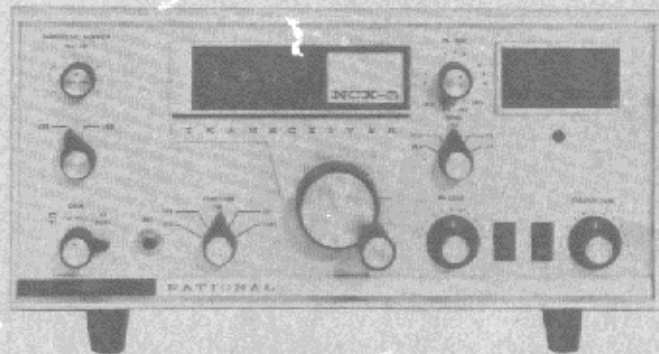

NATIONAL RADIO COMPANY
37 WASHINGTON STREET • MELROSE, MASSACHUSETTS

NCX-5 TRANSCEIVER



INDEX

	Page
SECTION 1 GENERAL DESCRIPTION	2
SECTION 2 INSTALLATION	3
2.1 Power Supplies	
2.2 Mobile Mounting	
2.3 Microphone Connections	
2.4 Mobile Speaker Installation	
2.5 Auxiliary Relay Control Terminals	
SECTION 3 OPERATION	5
3.1 Tuning Procedures	
3.2 Detailed Use of the Individual Controls	
SECTION 4 THEORY OF OPERATION	11
4.1 General	
4.2 The Transmitter	
4.3 The Receiver	
4.4 The VOX Circuits	
4.5 The Function Switches	
4.6 Relay Functions	
SECTION 5 ALIGNMENT	15
5.1 Equipment Required	
5.2 Initial Control Settings	
5.3 IF Alignment Procedure	
5.4 Balanced Modulator Adjustment	
5.5 Carrier Oscillator Setting	
5.6 Transmitter Bandpass Tuning	
5.7 Receiver Bandpass Tuning	
5.8 VFO Frequency Alignment	
5.9 VFO Linearity Adjustment	
5.10 VFO Sideband Switching Adjustment	
5.11 Temperature Compensating Adjustment	
5.12 Transmit Mixer and Driver Alignment	
5.13 Final Amplifier Preliminary Adjustment (10 Meter)	
5.14 Neutralizing Capacitor	
5.15 Final Amplifier Preliminary Adjustment (80—15 Meter)	
5.16 Final Amplifier Tuning Checks	
5.17 Local Oscillator Crystal Adjustment	
5.18 Parasitic Check	
5.19 Carrier Suppression, Sideband Suppression, Modulation, and ALC Checks	
5.20 Transmit—Receive Frequency Check	
5.21 LSB—USB Switching Check	
5.22 Switching Tests	
5.23 Transceive Vernier	
5.24 Anti-VOX Check	
5.25 VFO Jack	
SECTION 6 PARTS LIST	24
SECTION 7 VOLTAGE AND RESISTANCE MEASUREMENTS	26

SECTION 1

GENERAL DESCRIPTION

The NCX-5 is a five band high-performance transceiver for the 80, 40, 20, 15, and 10 meter amateur bands, intended for use in fixed home installations, as well as for portable and mobile application. The NCX-5 provides choice of SSB, CW, or AM operation with unusually accurate dial calibration and high frequency stability, together with operating features in all three modes normally available only with separate receiver-transmitter combinations.

A NATIONAL 8-pole crystal lattice filter with a 6 to 60 db. shape factor of 1.7:1 and a bandwidth of 2.8 Kc @ 6 db. provides sideband suppression and receiver selectivity previously found only in commercial communications equipment.

DIGITAL READOUT from a counter type display provides easy adjustment and resetability.

The SOLID STATE VFO eliminates the drastic initial warm-up drift so characteristic of tube type VFO's. The stability of this VFO, together with crystal controlled high frequency oscillators, results in a remarkably stable double conversion receiver and transmitter combination.

A TRANSCEIVE VERNIER control in the NCX-5 allows independent adjustment of the receiver frequency from that of the transmitter section over a range of ± 5 Kc from the displayed (transmitter) frequency.

SIDEBAND SELECTION is possible at the flick of a switch; (USB-LSB) without retuning the VFO. The operator may instantly select the opposite side-

band to reduce QRM or to make accurate SSB suppression checks with the calibrated S-meter.

ALC (automatic level control) is incorporated in the NCX-5. Effective talk power is increased and microphone gain and speech loudness are made non-critical by this system. The 10 db. range of the ALC circuit in the NCX-5 prevents "flat topping" and splatter.

An ALC INPUT JACK is provided on the NCX-5 for use with the NCL-2000 2 Kw linear amplifier for control of the NCX-5 by the ALC voltage from the NCL-2000.

Choice of VOX-PTT-MANUAL operation is performed from the front panel when operating AM or SSB.

BREAK-IN GRID BLOCK KEYING for CW operation accomplishes automatic transmit-receive switching at the tap of a key.

Two detectors are incorporated in the NCX-5: a product detector for SSB, CW, or "exalted carrier AM," and an excellent diode detector for AM operation.

A VFO INPUT JACK connects to the VX-501 optional VFO console. The VX-501, when used with the NCX-5, provides completely independent control of transmit and receive frequencies, as well as transceive control by either the VX-501 or the NCX-5. Besides its VFO function, the VX-501 provides for crystal control of the NCX-5 transmit, receive or transceive frequencies.

SECTION 2 INSTALLATION

2.1 POWER SUPPLIES:

The NCX-5 transceiver may be used with either the matching NCX-A 115/230 volt A.C. or the National 12 volt D.C. power supplies. We strongly recommend use of the National Power Supplies designed for the NCX-5 because of their extremely "stiff" voltage regulation and superior filtering.

NCX-A power supplies with serial numbers beginning with 73 or higher are designed for operation with the NCX-5 transceiver. NCX-A power supplies with serial numbers beginning with 44, 49, 57, 63, 69, or 72 *must be modified before use with the NCX-5 transceiver*. This modification may be easily made by connecting a 660 ohm 10 watt resistor in parallel with the two 330 ohm 10 watt resistors R-5 and R-6 in the NCX-A power supply. A partial schematic of the revised supply is shown on Figure #1.

2.2 MOBILE MOUNTING:

A mounting bracket is supplied as standard equipment with the NCX-5 transceiver. For mobile operation, this bracket should be mounted under the automobile dashboard with two #10, #12, or 1/4 x 20 screws. For maximum stability, these screws should be located as far apart as possible in the mobile mounting bracket. A pair of large threaded knobs hold the transceiver directly to the bracket. These knobs permit rapid installation or removal of the transceiver from the mount. Mobile operation usually results in considerable vibration and shock. For maximum frequency stability of the NCX-5 transceiver, it is important that all mounting screws used to hold the cabinet to the chassis and panel assembly be in place and firmly tightened. In mobile use, the rubber feet may be removed from the bottom of the NCX-5.

2.3 MICROPHONE CONNECTIONS:

The microphone input of the NCX-5 is equipped with a three circuit jack providing a ground on the main shank of the three circuit plug. The audio output of a high-impedance ceramic or dynamic microphone (a crystal microphone may be used, but is not recommended for mobile operation) should be connected to the ring of the three circuit jack. If the microphone is equipped with a push-to-talk button, the push-to-talk button should be so wired that the

tip of the microphone plug is connected to the grounded shank of the plug when the push-to-talk button is pressed. The microphone push-to-talk button is connected to the -40 volt bias.

— CAUTION —

Accidental interchange of the wiring on the microphone plug will result in application of -40 volts to the microphone cartridge, which may damage the microphone.

The microphone input jack of the NCX-5 is equipped with a grounding contact so that no modulation of the transceiver is possible when the microphone plug is removed. Microphone connections are illustrated in figure No. 1. We recommend the use of a good quality, wide-range microphone, since all necessary restriction of audio bandwidth is accomplished in the NCX-5 crystal lattice filter. The PTT circuit of the microphone should be modified to permit VOX operation without depressing the PTT button. This may be done by bending one of the shorting contacts inside the microphone so that it does not short the microphone cartridge terminals when the button is released.

2.4 MOBILE SPEAKER INSTALLATION:

When the NCX-5 is installed in an automobile for use with the D.C. supply, it will usually be most convenient to use the speaker of the regular automobile broadcast radio. Two leads should be brought out of the 12 terminal Jones plug at the rear of the NCX-5 (pins 5 and 7) and connected to the speaker through a DPDT switch mounted under the dash to allow choice of speaker operation with either the NCX-5 or the standard broadcast radio.

2.5 AUXILIARY RELAY CONTROL TERMINALS:

A pair of SPST relay terminals rated at 3 amperes current capacity is provided at the rear of the NCX-5 to allow control of accessory equipment such as the NCL-2000 amplifier. Terminals are open during receive, closed during transmit.

INSTALLATION

FIGURE 1

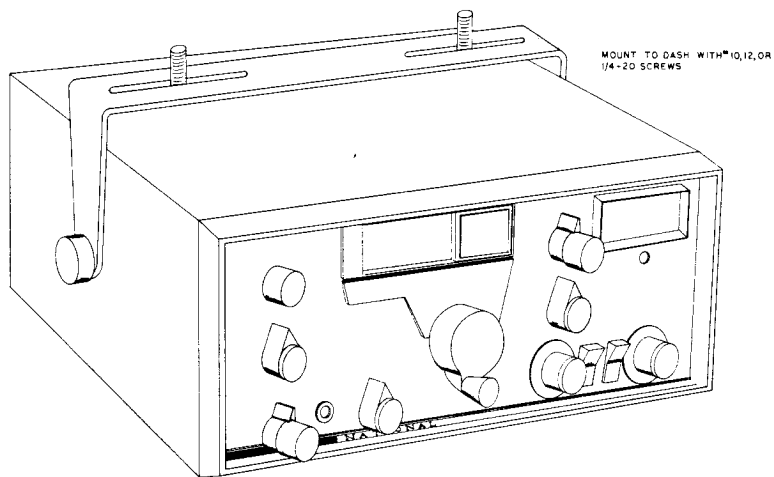

- 1 POWER SWITCH
- 2 POWER SWITCH
- 3 -80VOLT BIAS@6MA
- 4 12.6VOLT HEATER@5A
- 5 SPEAKER GROUND
- 6 COMMON GROUND
- 7 SPEAKER
- 9 +280VOLT@200MA
- 11 +700VOLT@300MA

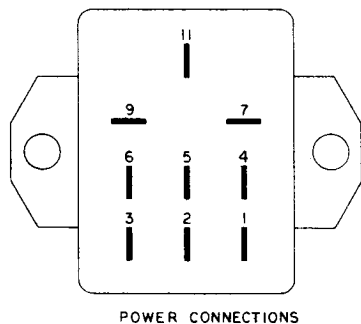

POWER CONNECTIONS

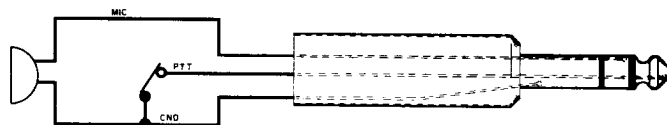

MICROPHONE CONNECTIONS

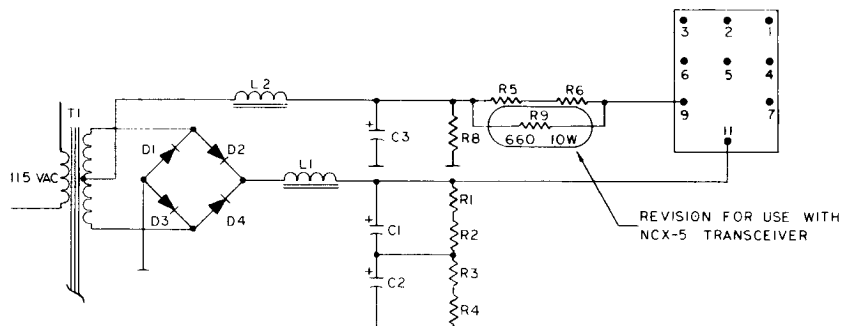

SECTION 3 OPERATION

3.1 TUNING PROCEDURES:

3.1.1 PRELIMINARY ADJUSTMENT

— CAUTION —

BEFORE ATTEMPTING TO OPERATE THE NCX-5 TRANSCEIVER, THE FOLLOWING PRELIMINARY CONNECTIONS SHOULD BE MADE: A SUITABLE ANTENNA OR DUMMY LOAD PRESENTING 40 TO 60 OHMS RESISTIVE LOAD IMPEDANCE SHOULD BE CONNECTED TO THE ANTENNA TERMINALS, A PROPER POWER CABLE SHOULD BE CONNECTED FROM THE POWER SUPPLY TO THE NCX-5 TRANSCEIVER, AND A MICROPHONE OR KEY SHOULD BE CONNECTED TO THE APPROPRIATE INPUT JACKS. THE *FUNCTION SWITCH* SHOULD REMAIN IN THE *OFF* POSITION WHILE THESE CONNECTIONS ARE BEING MADE.

1. Set front panel controls as follows:

TRANSCEIVE VERNIER in OFF position (pushed in)

RF GAIN fully cw (clockwise)

AUDIO GAIN at 9 o'clock

BAND and MAIN TUNING to desired band and frequency

PA TUNE, PA LOAD, and EXCITER TUNE fully ccw

VOX-PTT switch in either position

MOX-OFF switch: OFF

SIDEBAND switch on desired sideband (usually LSB on the 80 and 40 meter bands, and USB on 20, 15, and 10 meter bands).

2. VOX GAIN, VOX DELAY CARRIER INSERTION, and MIC GAIN inside top cover should be set fully ccw.
3. BIAS adjust on rear panel should be set at 12 o'clock.

3.1.2 RECEIVER TUNE-UP (SSB)

1. Turn *FUNCTION* switch from *OFF* to *SSB*. After several seconds warm-up, the NCX-5 transmit-receive relay should close with an audible click. The NCX-5 is now in a receive condition on the selected band and frequency.
2. Adjust *PA TUNE* and *EXCITER TUNE* for maximum S-meter reading or background noise. This adjustment automatically sets up approximate transmit tuning since these controls are common for both transmitter and receiver.
3. Adjust *AUDIO GAIN* for comfortable listening level.

3.1.3 TRANSMITTER TUNE-UP (SSB)

— CAUTION —

DO NOT PROLONG TUNE-UP PROCEDURES MORE THAN 30 SECONDS AT A TIME IN ORDER TO PREVENT UNNECESSARY OVERHEATING OF COMPONENTS DURING OUT-OF-RESONANCE CONDITIONS. AFTER EXPERIENCE IS GAINED, TUNE-UP MAY BE ACCOMPLISHED IN A MATTER OF A FEW SECONDS.

1. Turn *FUNCTION* switch to *TUNE* and adjust *EXCITER TUNE* for maximum meter reading.
2. Adjust *PA TUNE* for minimum meter reading (dip) indicating proper tuning of the Pi network. Slowly rotate the *PA LOAD* control cw and dip meter reading with *P.A. TUNE* control until meter reads 300 MA.

3. Return FUNCTION switch to SSB. Push the MOX-OFF switch to the MOX position.

NOTE:

IF THIS IS THE FIRST TIME THAT THE NCX-5 HAS BEEN PLACED IN OPERATION, THE REAR PANEL BIAS CONTROL SHOULD BE ADJUSTED. THE NCX-5 IS IN TRANSMIT WITH THE MOX-OFF SWITCH IN THE MOX POSITION. THE REAR PANEL BIAS CONTROL SHOULD BE ADJUSTED UNTIL THE METER READS BETWEEN 50 AND 60 MA.

Return the NCX-5 to the receive condition (MOX switch OFF).

3.1.4 MOX OPERATION

1. The NCX-5 transceiver will now operate in both the transmit and receive modes using the MOX-OFF switch for transmit-receive control.

3.1.5 VOX OPERATION

1. Place the MOX-OFF switch in the OFF position.
2. Place front panel VOX-PTT switch to VOX.
3. Turn receiver AUDIO GAIN control (on the front panel) and VOX DELAY control (inside the top cover) completely ccw.
4. Rotate the VOX GAIN control (inside the top cover) until the relay just trips reliably while speaking into the microphone. Adjust VOX DELAY until VOX relay holds in for the desired time after speaking. These adjustments interact to a small degree, and it may be necessary to repeat all adjustments once or twice to optimize results.

Mobile VOX operation is quite easy and practical, but VOX GAIN and MIC GAIN should be adjusted for maximum close-talking to prevent car and wind noises from tripping the relay.

3.1.6 PTT OPERATION

1. Place the MOX-OFF switch in the OFF position.
2. Place the VOX-PTT switch to PTT.
3. Connect a suitable push-to-talk switch as shown in figure No. 1. The NCX-5 will operate in both the transmit and receive modes

by control from the external push-to-talk switch. The VOX DELAY control remains connected in the PTT mode and may be adjusted for fast or slow return to receive when the push-to-talk button is released.

3.1.7 CW OPERATION

1. It is assumed that the NCX-5 has been set up for SSB operation and that it is now desired to operate CW.
2. Insert key plug in rear panel jack.
3. Turn FUNCTION switch to TUNE and adjust transmitter as for SSB operation.
4. Turn FUNCTION switch to CW, depress key, and rotate the CARRIER INSERTION control (inside top cover) clockwise until meter reads 300 ma. Do not continue to rotate the CARRIER INSERTION control beyond this point.
5. The NCX-5 is now tuned for CW operation and is ready for full break-in operation. When the key is depressed to start sending, the VOX relay will hold in until the operator stops sending, and then will automatically switch to receive. By adjusting the VOX DELAY control (inside the top cover), the operator may set the "hold-in" relay time to his liking.

3.1.8 AM OPERATION

1. It is assumed that the NCX-5 has been set up for SSB operation and that it is desired to operate AM.
2. Either MOX, VOX, or PTT operation should be selected.
3. Turn FUNCTION switch to TUNE, and adjust transmitter as for SSB operation.
4. Turn FUNCTION switch to AM, press MOX-OFF switch to MOX, and rotate the CARRIER INSERTION control (inside top cover) clockwise until meter reads 150 ma.
5. Advance MIC GAIN until meter just flickers on voice peaks.
6. The NCX-5 is now adjusted for AM operation, and the AM detector is automatically in use.

3.2 DETAILED USE OF THE INDIVIDUAL CONTROLS:

The operating instructions in Section 3.1 of this manual enable rapid setup of the NCX-5 for SSB, AM, or CW transmission. Careful study of the following paragraphs will help you get the best performance from your NCX-5 transceiver.

3.2.1 MAIN TUNING CONTROL AND DIGITAL DIAL READOUT

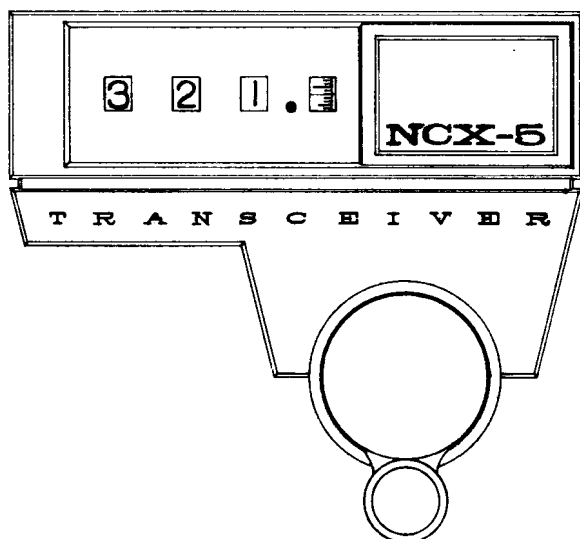

The NCX-5 transceiver incorporates a digital-type direct frequency readout to allow frequency adjustment to 1 Kc without interpolation between divisions. The VFO is accurate to 1 Kc, and it is read by adding the frequency in kilocycles shown on the counter dial to the frequency in megacycles shown on the BANDswitch. With the BANDswitch in the 14.0 Mc position, the frequency as shown in the illustration above is 14.321 Mc. If the BANDswitch were in the 3.5 Mc position, for example, the above frequency would be 3.5 Mc plus 321 Kc, or 3.821 Mc.

To provide even greater resettability, the NCX-5 readout incorporates a fourth window, as shown above, calibrated in ten one-hundred-cycle divisions. The illustration above actually indicates that 321 Kc plus 200 cycles (321.2 Kc) should be added to the BANDswitch frequency.

3.2.2 DIAL SET

The dial of the NCX-5 may be adjusted to exact frequency, such as a 100 Kc marker from the optional plug-in XCU-27 calibrator, by tuning to the marker frequency in the receiver and then by pulling *out* the main tuning knob of the NCX-5 and turning the knob until the dial reading corresponds to the known marker frequency.

3.2.3 THE FUNCTION SWITCH

Note the various interlocking features of the FUNCTION switch. In the SSB or AM positions of the FUNCTION switch, either VOX, MOX, or PTT operation may be used (see paragraphs 3.2.8 and 3.2.9). The rear panel key jack is disconnected in the SSB or AM positions, thus allowing a key to be left plugged into the NCX-5 at all times. Accidental closing of the key will not trip the unit to transmit if the FUNCTION switch is in either the SSB or AM position.

In the SSB position, the product detector is in use and the CARRIER INSERTION control is disconnected from the balanced modulator circuits. The CARRIER INSERTION control has no effect in the SSB position of the FUNCTION switch and may be preset for either CW or AM operation.

In the AM position, the diode detector is selected. Bias is applied to the carrier oscillator during AM receiving periods, thus silencing the beat frequency oscillator of the receiver. The CARRIER INSERTION control is connected and should be adjusted according to paragraph 3.2.5.

If the front panel FUNCTION switch is in the CW position, the rear panel key jack is connected for automatic break-in operation. At the same time, the plate of the microphone preamplifier is grounded to prevent accidental modulation of the transmitted signal by a microphone connected to the NCX-5. During CW operation, the VOX-PTT switch can be in either the VOX or PTT positions without any effect on the operation of the transceiver. The slight audio "beep" which may be heard from the loudspeaker at the beginning of each keying cycle is the result of the extremely fast attack time of the break-in CW circuit which eliminates "clipping" the first dot. The CARRIER INSERTION control is connected and should be adjusted according to paragraph 3.2.5.

Finally, in the TUNE position of the FUNCTION switch, the keying circuit is internally grounded, placing the NCX-5 in transmit condition. At the same time, full carrier is inserted, and adjustment of the CARRIER INSERTION control has no effect. It is important to note that if the FUNCTION switch is placed in the TUNE position, and an antenna is connected to the NCX-5, full power transmission of a CW note will occur and can cause unwanted interference. Tune-up procedure should therefore be limited to as short a time as possible.

3.2.4 THE PA TUNE AND PA LOAD CONTROLS

Adjustment of the PA TUNE and PA LOAD controls is interdependent. For normal tune-up, the FUNCTION switch is placed in the TUNE position. The EXCITER TUNE control is set for maximum meter indication. The PA TUNE control is then set for minimum indication, indicating resonance of the Pi network. For a normal 40 to 60 ohm resistive antenna, the PA LOAD control should be rotated clockwise to increase the meter reading. As this is done, there will be some interaction with the PA TUNE control, and it will be necessary to slightly adjust PA TUNE for minimum meter indication. As the PA LOAD control is advanced, the minimum meter reading will increase. Proper loading for 200 watts peak input occurs at 300 ma (marked in red on the meter scale). This loading current *should not be exceeded*, since the Pi network design is such that additional

power input from a 700 volt supply will *not* result in additional power output. Above 300 ma the efficiency of the NCX-5 final amplifier will be impaired, and no further output will be obtained.

Proper operation of any linear final amplifier depends on proper idling current adjustment and on sufficient drive for adequate peak plate current during an off-resonance condition. The adjustment of the bias setting of the NCX-5 final amplifier is discussed in paragraph 3.1.3. Assuming this setting has been made for an idling current between 50 and 60 ma, it should be possible to obtain a *momentary* maximum off-resonance plate current in excess of 350 ma when the PA TUNE control is rotated away from the point of minimum current. If 700 volts is being properly supplied to the plate circuit of the final amplifier, and the EXCITER TUNE control is properly adjusted, this off-resonance current should exceed 350 ma. If this current cannot be achieved, the cause should be found. Typical causes may include any of the following: improper Bias setting, improper EXCITER TUNE adjustment, low plate supply voltage to the final amplifier under full load conditions, low driver B+, defective final amplifier tubes or driver tube, or improper alignment of the exciter stages resulting in low driving signal.

As mentioned above, low plate supply voltage to the final amplifier will frequently result in difficulty in obtaining a suitable off-resonance current. The NCX-A power supply is rated to deliver 700 volts to the final amplifier with a 115 volt A.C. input. The D.C. power supply is rated to deliver 700 volts to the plate circuit of the final amplifier with a 14.0 volt input to the power supply. If the A.C. line voltage or the mobile battery supply voltage is low, the power supply output will be reduced. Under these conditions, an off-resonance plate current of *less* than 350 ma will probably occur. This will not impair the operation of the NCX-5 transceiver, provided that the PA LOAD control is not adjusted for excessive loading conditions. In no event should the LOAD control be advanced so that the plate current at the resonant dip exceeds 85% of the off-resonant plate current, which is noted by momentarily detuning the PA TUNE control.

In many instances an antenna load that is outside the 40 to 60 ohm range of the Pi network will be used with the NCX-5. Antennas presenting this type of impedance should, if at all possible, be adjusted to present a proper load at the NCX-5 antenna terminals. This can be done through the use of matching networks and, in many instances, by simply tailoring the length of the antenna transmission line to modify its terminal impedance.

Generally speaking, if the NCX-5 exhibits a resonant plate current in the dip in excess of 300 ma with the PA LOAD control rotated to its full counter-

clockwise position, the antenna load impedance is below 40 ohms. If, on the other hand, the resonant dip is still less than 300 ma with the PA LOAD control rotated to its full clockwise position, the antenna load impedance is above 60 ohms. It is possible to modify the Pi network output capacitors of the NCX-5 to take care of some misloading in these directions. With the PA housing removed, a group of four mica capacitors will be seen just below the BANDswitch and connected between the BANDswitch and chassis. These capacitors, C-37 (3.5 Mc), C-38 (7 Mc), C-39 (14 Mc), and C-182 (21 Mc) are, respectively, 1000, 470, 220, and 220 pF. They appear in parallel with the front panel PA LOAD control as shown on the schematic diagram and may be altered to extend the range of the Pi network. If the load impedance is too low, the capacitance should be increased. A good quality silver mica capacitor may be used for this purpose. It is advisable to use as large a case size on these capacitors as can be obtained.

There is of course some interaction of tuning between the PA LOAD control and the PA TUNE control. If load matching as described in the preceding paragraph is attempted, it is possible that the tuning of the PA TUNE control will be shifted to a point where this control will no longer cover the entire amateur band. In this event, it will be necessary to use external matching techniques. It is also possible that the antenna line will introduce an inductive or capacitive component to the NCX-5 antenna terminals. In this event, there may be also a shift of the PA TUNE control so that it will not tune over the entire amateur band. Again it will be necessary to alter the antenna impedance by means of an external matching network or correction of the antenna difficulties. SSB operation should not be attempted unless the NCX-5 is properly matched and loaded because severe distortion can result with any improperly matched SSB transmitter or receiver.

3.2.5 CARRIER INSERTION CONTROL

During tune-up (with the FUNCTION switch in the TUNE position), the CARRIER INSERTION control is inoperative. Full carrier is automatically inserted. In the AM and CW position, the CARRIER INSERTION control may be preset and will vary the carrier level from zero to full output as indicated by the meter. In the SSB position, the CARRIER INSERTION is again inoperative, and the carrier suppression is over 50 db at all times.

3.2.6 CALIBRATOR CONTROLS

When the accessory XCU-27 100 Kc calibrator is plugged into the octal socket on the rear apron, 100 Kc crystal markers are available for precise calibration of the NCX-5. The calibrator is activated by means of a pull-push switch on the AUDIO GAIN control. The dial may then be set by following the instructions in paragraph 3.2.2.

3.2.7 S-METER ADJUSTMENT

Proper S-meter adjustment of the NCX-5 is obtained by disconnecting the antenna and detuning the EXCITER TUNE control while the NCX-5 is set for SSB reception. With the RF GAIN fully clockwise (maximum gain), the S-meter adjustment (in front right corner of chassis) is rotated until the meter indicates between 0 and 1 "S" units.

3.2.8 VOX-PTT SWITCH AND VOX CIRCUIT ADJUSTMENTS

The VOX-PTT switch may be set to either mode, depending on preference and availability of a push-to-talk button on the microphone. Proper microphone jack connections are illustrated in figure No. 1.

Assuming that VOX operation is selected, the operator will find that the VOX GAIN and VOX DELAY control settings of the NCX-5 are remarkably free from interaction. The extreme VOX sensitivity available in the NCX-5 permits full anti-vox insertion at all times. As a result, no anti-vox control adjustment is required. With the VOX DELAY control fully ccw, VOX GAIN control is advanced slowly until the microphone just trips the NCX-5 to transmit with normal speech level. Mobile operation requires close talk to the microphone, since the high level of road, wind, and motor noises will otherwise tend to accidentally trip the VOX circuit. The VOX DELAY control is then adjusted for the desired release time.

It should be further noted that PTT and CW break-in operation are obtained through use of the VOX circuit. However, the VOX GAIN control will have no effect on this operation and may be left in any position. The VOX DELAY control is effective on both PTT and CW break-in operation and should be adjusted to the operator's liking for delay at the end of the transmission.

3.2.9 THE MOX-OFF SWITCH

The MOX-OFF switch in the MOX (manual operation) position places the NCX-5 in the transmit mode, regardless of the position of the VOX-PTT switch or the FUNCTION switch. This position is useful for manual operation when the microphone is not equipped with a PTT switch. When the MOX-OFF switch is returned to the OFF position, VOX or PTT operation may be selected by the VOX-PTT switch.

3.2.10 TRANSCEIVE VERNIER CONTROL

The TRANSCEIVE VERNIER control allows ± 5 Kc separation of the receive frequency from the transmit frequency of the NCX-5. It is actuated by pulling the control *out* and rotating the knob to increase or decrease receiver frequency. The transmit frequency of the NCX-5 remains unchanged at all

times—*only the receiver frequency* is affected by the TRANSCEIVE VERNIER. The NCX-5 TRANSCEIVE VERNIER will be found to be extremely useful in AM or CW QSO's, as well as in SSB net operation. It allows the operator to tune to the desired AM or CW station with the VERNIER control pushed OFF, thus placing the transmit section of the NCX-5 on frequency. Then the TRANSCEIVE VERNIER can be pulled ON to offset receiver frequency enough to allow tuning of the station to the proper part of the filter passband for best copy without "walking" of the transmit signal.

To escape QRM during a QSO on SSB, the TRANSCEIVE VERNIER can be used to find a clear channel. Once a clear channel is found, the NCX-5 receiver is placed back on frequency simply by pushing the control IN, and arrangements may be made to QSY. The casual listener may also listen to two adjacent QSO's by merely turning the TRANSCEIVE VERNIER control on and off and thereby instantly place the NCX-5 receiver on either frequency.

3.2.11 MIC GAIN CONTROL

For SSB operation, set up the NCX-5 by proper tuning of the final amplifier and exciter stages, and advance the MIC GAIN control until the meter reads between 100 and 125 ma on speech content from the microphone. The single sideband audio information so developed has a rapidly varying energy content and the meter will rapidly fluctuate between the 40 to 50 ma idling current and the 100 to 125 ma meter reading. Actual peak current is about 300 ma. This fluctuation will be affected by the nature of the speech content and the individual voice. Generally speaking, the indication will be higher for long drawn out vowel sounds than it is for crisp consonant sounds.

Inclusion of an effective ALC circuit in the NCX-5 has diminished the importance of the microphone gain control. A MIC GAIN control has been provided because of the wide variety of microphones and large variation in output levels even of microphones of the same type. As the MIC GAIN control is rotated from the full ccw position, the current on voice peaks will increase to approximately 125 ma. As MIC GAIN is further increased, little additional change will be noted on the meter. The MIC GAIN control should be set *slightly* above the point where average current reaches the 125 ma level on the meter. Should the control be advanced well above this point, the ALC can no longer handle the drive level, and severe distortion may be generated.

For AM operation with the CARRIER INSERTION control set as described in paragraphs 3.1.8 and 3.2.5, there will be a steady meter reading of 150 ma. If the MIC GAIN control is advanced during speech, AM modulation of the final amplifier will occur. When the MIC GAIN control setting

reaches a point where the meter just indicates a slight flicker of speech peaks, modulation is 100%. Operation with the MIC GAIN control above this point should be avoided, since excessive drive will cause clipping of the modulation envelope, and this will result in unwanted spurious transmission outside of the passband of the NCX-5.

3.2.12 THE TEN-METER SEGMENT SWITCH

If it is desired to operate on one of the 10-meter segments other than 28.5-29.0, selection of the appropriate 500 Kc segment is made by the 10-meter switch concentric with the PA TUNE control. The crystal for the segment from 28.5 to 29.0 is supplied with the NCX-5. If one of the other segments of the band is desired, the appropriate crystal must be plugged in. Sockets are near the existing crystal on the sub-chassis in the front right-hand corner of the NCX-5. The corresponding frequencies and crystals are: 28.0-28.5 Mc segment—crystal frequency 24.5 Mc; 29.0-29.5 Mc segment—crystal frequency 25.5 Mc; and 29.5-30.0 Mc segment—crystal frequency is 26 Mc. These frequencies are also shown on the frequency chart under "Theory of Operation." Ten-meter segment crystals are available from the Service Department of the National Radio Company.

3.2.13 CARRIER INSERTION CONTROL AND CARRIER BALANCE

The carrier balance control R-155 of the NCX-5 is internal and has been factory adjusted for proper carrier suppression. Readjustment should not be required for normal SSB operation. If desired, it may be set in the following manner.

Set the FUNCTION switch to SSB. Place the NCX-5 in a transmit condition either by means of the push-to-talk button or by the MOX-OFF switch. In either event, the MIC GAIN control should be in

full ccw position so that no audio modulation will occur. The carrier balance control is then adjusted for minimum meter indication. This meter reading should be between 50 and 60 ma if the BIAS control is properly adjusted. When the carrier balance control is properly set, it may be left in this position for all subsequent operation. A more precise indication of carrier balance control setting may be obtained either by using an oscilloscope connected to the antenna line or by listening to the carrier on a separate receiver. With proper carrier balance and tuning of the transceiver circuits, voltage on the antenna line should not exceed 0.5 volts peak-to-peak as indicated on the oscilloscope.

For AM operation, it is necessary to adjust the CARRIER INSERTION control cw from zero until the meter indicates a final amplifier current of 150 ma. This corresponds to approximately 100 watts input to the final amplifier, thus assuring operation of the tubes within their plate dissipation rating.

For CW operation, it is necessary to adjust the CARRIER INSERTION control cw from its zero setting until a meter indication of 300 ma is obtained. This assures an input to the final amplifier of 200 watts during key down transmit conditions of CW operation. Normal keying wave forms approximate a 50% duty cycle; that is, there is full input for about 1/2 of the time and no power for the remaining time. Thus the time-averaged input to the final amplifier is still approximately 100 watts, assuring conservative operation of the final amplifier.

In the SSB position the CARRIER INSERTION control is inoperative and full carrier suppression is obtained at all times. When the FUNCTION switch is turned to AM or CW, the CARRIER INSERTION control becomes operative and carrier is automatically inserted according to the preset position of the CARRIER INSERTION control.

**BLOCK DIAGRAM
FIGURE 2**

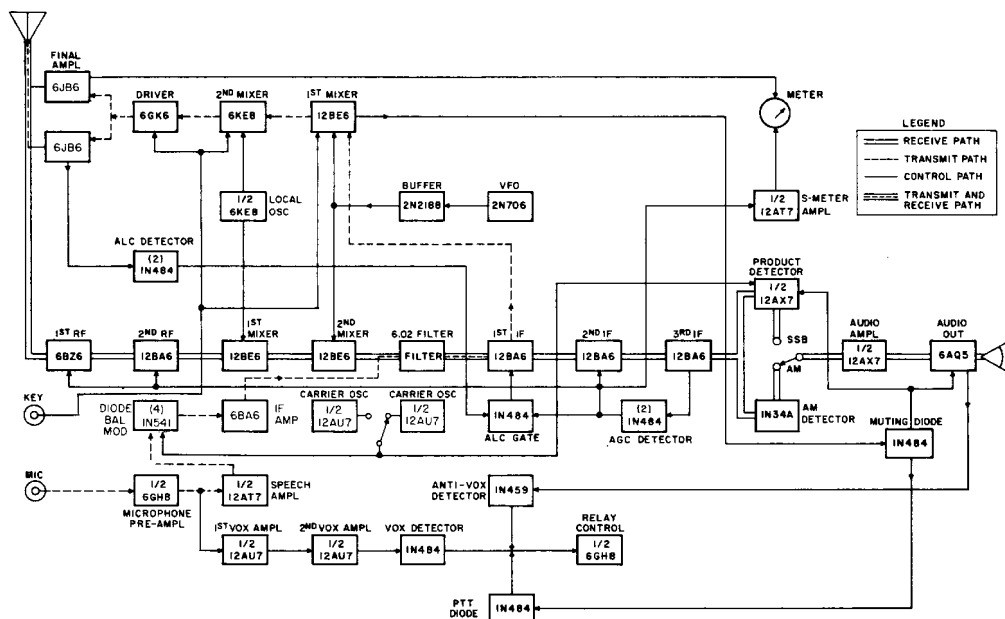

SECTION 4

THEORY OF OPERATION

4.1 GENERAL:

The NCX-5 transceiver, designed to cover the 80 through 10 meter amateur bands, combines a double conversion superheterodyne receiver and single sideband transmitter, both employing a common crystal lattice filter. The final Pi network, mixer and driver tuning circuits of the transmitter also serve as RF circuits for the receiver. The carrier oscillator and VFO are common to the receiver and transmitter circuits while the receiver first IF stage is used as a low level amplifier in the transmitter-exciter function. The use of common filter and RF input components results in an extremely sensitive and image-free, selective receiver and in a high quality, low distortion SSB transmitter.

The operation of the NCX-5 is best understood by reference to the block diagram, figure 2, and the frequency chart, figure 3.

4.2 THE TRANSMITTER:

The transmit signal path of the NCX-5 is indicated on the block diagram by a dashed line starting at the mike jack and carrier oscillator. The microphone input circuit is designed for high-impedance dynamic or crystal microphones and provides for a push-to-talk microphone circuit. The microphone is connected directly to the grid of the pentode section of a 6GH8 (V8A) tube which operates as a preamplifier. The signal is then fed through the microphone gain control to one triode section of the 12AT7 (V6A) speech amplifier. The plate circuit of this speech amplifier is coupled to the diode balanced modulator.

A 12AU7 (V7) tube is used for the two carrier oscillators. Each crystal is permanently connected to its triode section, and sideband switching is accomplished by applying a negative bias to the section to be turned off. The carrier signal appears across a common resistive plate load and is fed to the diode balanced modulator. The ring balanced modulator has both a resistive balance and a capacitive phase balance. The balanced primary winding of the output transformer is coupled to a single ended winding which feeds the input of the 6BA6 (V-10) transmit IF stage. The transmit IF stage feeds a double tuned circuit. The secondary winding serves as an input source for the eight pole crystal lattice filter.

The crystal lattice filter is resistance terminated and coupled directly to the grid of the 12BA6 (V15) first IF stage. The single-tuned plate circuit is coupled to the grid of the 12BE6 (V3) first transmit mixer.

The VFO uses a 2N706 (Q1) NPN transistor oscillator and a 2N2188 (Q2) PNP transistor buffer. All biasing resistors and tank circuit capacitors are chosen for low noise and temperature characteristics. Power for the VFO circuits is double-regulated by a zener diode regulator fed from the regulated +150 volt bus. The result is a VFO circuit with a total drift from "turn on" of less than 100 cycles in any ten-minute period, including variations of external supply voltage and ambient temperature. The main tuning capacitor is completely linear with an accuracy of 1 Kc at any point within the 500 Kc tuning range. Output from the VFO is taken from the collector of the 2N2188 (Q2) and fed to the oscillator grid of the 12BE6 (V3) first transmit mixer.

The output from the first transmit mixer (V3) is always in the 3.5 to 4.0 Mc band. This signal is fed through a bandpass double-tuned circuit to the grid of the pentode section of the 6KE8 (V4B) second transmit mixer. The triode section of the 6KE8 is used as a crystal oscillator which feeds both the second transmit mixer and the first receive mixer.

The plate circuit of the second transmit mixer is single-tuned and feeds the grid of the 6GK6 (V5) driver. The single-tuned plate circuit of the driver feeds the grid of the final amplifier. The coils in the plate circuits of the transmit mixer and driver are band switched for the 80, 40, 20, 15, and 10 meter amateur bands. The tuning gang is tracked so that exciter tuning can be accomplished with only one control. The gains of the transmit mixer and driver are such that a driving signal in excess of 100 volts can be obtained at the grid of the final amplifier, thus assuring linear operation of the exciter to well above the level necessary for proper drive.

The final amplifier employs a pair of 6JB6 (V1 and V2) tubes operating in parallel. A bias control on the rear apron sets proper idling current. The plates of the 6JB6 final amplifier are coupled to a high-efficiency Pi network. The band switch selects proper inductance, tuning and load capacitance to match a 40 to 60 ohm resistive load over the entire 80, 40, 20, 15, and 10 meter amateur bands. The Pi network is designed for continuous operation at

a power level of 200 watts input. A small adjustable capacitor coupled from the plate of the 6JB6 final amplifier to the partially by-passed return of the final grid circuit coils (driver plate coils) provides neutralization. When the final amplifier is properly neutralized, maximum output on a matched antenna will occur at the point of plate current dip as indicated on the meter.

An effective ALC (automatic level control) circuit is included. If the final amplifier grids are overdriven on voice peaks, the grids will actually see a driving signal positive with respect to the cathodes, and grid current will result. This current will cause a negative voltage change on the bias circuit. The resulting audio signal on the bias circuit is capacitively coupled to a voltage-doubling rectifier. This rectifier will provide a negative D.C. output which is coupled to the grid return of the 12BA6 (V15) first IF amplifier. When overdrive occurs, the gain of the first IF amplifier is reduced, resulting in less driving signal at the final amplifier. Charging takes place rapidly from the low-impedance bias source through the rectifying diodes, but the negative ALC voltage cannot discharge through the reverse biased diodes, resulting in a fast attack—slow release action. A gating diode prevents cross connection of the ALC and AGC circuits at the common IF grid return point. The ALC circuit will provide automatic level control for input signal variations of more than 10 db., and makes the setting of the MIC GAIN control quite noncritical. In addition, sudden changes in voice level or disturbing background noises are all instantly controlled without overdrive and distortion of the NCX-5 transmitter.

4.3 THE RECEIVER:

The receiver circuits are indicated by the double solid lines in the block diagram. The receiver RF circuits are common to the transmitter RF circuits. The high-impedance point of the transmitter Pi network is capacitively coupled to the grid of a 6BZ6 (V11) RF amplifier. The tuned circuits at the plate of the transmit driver and plate of the transmit mixer are the input and output circuits of the 12BA6 (V12) second RF amplifier. They provide for receiver RF selectivity and common receiver-transmitter tuning. The output from the second RF amplifier is coupled to the signal grid of the first receive mixer 12BE6 (V13). The oscillator grid is fed from the 6KE8 (V4A) crystal oscillator. The plate of this mixer is coupled to the signal grid of the 12BE6 (V14) second receive mixer. VFO signal is coupled to the oscillator grid of this mixer. The plate circuit of the second receive mixer is connected directly across the secondary of the transmit IF transformer which serves as the input coil to the crystal lattice filter.

The output of the crystal lattice filter, as in the transmitter, couples to the input of a three stage single-tuned IF amplifier operating at approximately 6.02 MC. The detectors and AGC circuits are fed

through separate voltage dividers. The product detector employs one triode of the 12AX7 tube (V18A) with the signal from one IF voltage divider fed to the grid. A BFO signal is coupled from the crystal controlled 12AU7 (V7) carrier oscillator to the cathode of the product detector, and the resulting audio signal is obtained across a resistive load in the plate circuit. For AM operation, a separate diode detector is connected.

The output from the detectors is coupled to the audio gain control, and then to the grid of the remaining triode section of the 12AX7 (V18) tube functioning as a grid-leak biased, first audio amplifier. The plate circuit is coupled to the grid of the 6AQ5 (V19) audio output stage. The audio output stage feeds the output transformer having a 3.2 ohm secondary. This output signal is also available at the phone jack. The low-impedance nature of the phone jack feed permits use of either high- or low-impedance phones.

A secondary feed is obtained from the plate circuit of the last IF amplifier and is fed to a voltage-doubling AGC rectifier. The low-impedance driving source provides a rapid charge of the AGC bus. When the signal disappears, the negative AGC bus cannot discharge through the diodes, which provides a long release time, thus giving the AGC a very effective, fast-attack, slow-release action. The AGC is fed to the grid of the remaining half of the 12AT7 (V6B) S-meter amplifier. AGC is connected to the grid returns of the RF stage, second IF stage, and through the gating diode to the first IF stage for control.

4.4 THE VOX CIRCUITS:

Before considering the switching operations, we must first discuss the VOX circuits.

The signal which trips the relay from receive to transmit is derived from two sources. The first source is the VOX signal which is picked up after the microphone preamplifier and separately amplified in a two stage amplifier consisting of V9A and V9B (12AU7). The other signal is derived from the plate of the audio output tube and is called the ANTI-VOX signal.

Both signals are rectified, the VOX signal so as to make a negative voltage, the ANTI-VOX signal making a positive voltage. The two D.C. voltages are applied in series to the grid of the relay control tube. The circuit constants in the VOX and ANTI-VOX detectors are arranged so that the D.C. voltage derived from the ANTI-VOX detector is always larger than the voltage generated in the VOX channel from loudspeaker information.

Additional information entering the microphone is amplified through the VOX amplifier and will develop enough negative voltage at the grid of the relay tube to let the relay fall off and place the circuit into transmit position.

The VOX and ANTI-VOX detector time constants are so arranged that the circuits will drive the relay tube grid negative in a very short time. At the end of transmission, the relay control signal cannot discharge backwards through the diodes. The discharge time is controlled by R7, the DELAY control which can be set from a fraction of a second to several seconds. This circuit is also used in the CW position and will be discussed later.

4.5 THE FUNCTION SWITCHES:

The following paragraphs describe the operation of the various switching circuits with the FUNCTION switch in all possible positions.

4.5.1 FUNCTION SWITCH OFF

In this position the FUNCTION switch interrupts the primary power, either directly in case of the NCX-A power supply or through a remote relay in the NCX-D 12 volt D.C. supply. The position of all other switches becomes irrelevant.

4.5.2 FUNCTION SWITCH SSB

In this position the following circuits are set up: The VOX-PTT switch, the product detector, and the microphone amplifier are connected into the circuitry. The key jack is disconnected to prevent accidental keying. The CARRIER INSERTION control is disconnected and a negative bias is applied to the 6BA6 (V-10) transmit IF stage, to reduce gain.

Now three different types of operation are possible:

4.5.2.1 VOX OPERATION

VOX switch in VOX position and the MOX-OFF switch in OFF position. In this combination the VOX and MOX switches ground the keying diode. Voice information from the microphone will override the ANTI-VOX, as described before, tripping the relay. The relay will transfer B+ to the final and other transmitting tubes. Negative bias is removed from various transmitting tubes and applied to receiving tubes and the first audio amplifier for quiet switch over. At the end of transmission and after the preset DELAY, the relay will pull in again, placing the set in receiving condition.

4.5.2.2 PUSH-TO-TALK OPERATION

VOX-PTT switch on PTT, MOX-OFF switch on OFF position. The output of the VOX amplifier is now shorted to ground, and the push-to-talk contact is connected across the transmit bias line. When the push-to-talk contact is pushed, the bias line (135) is grounded, which removes the disabling bias from transmitting tubes. The bias is also removed from the

first transmit mixer. The screen of this mixer tube V3 (12BE6) will now draw current, causing a reduction of screen voltage. A voltage divider connected from this screen to the -80 bias line will develop a negative signal which is tied through the VOX-PTT and the MOX switch to the keying and PTT diode. The keying and PTT diode feeds the grid of the relay tube. The relay tube will be biased off, the relay falls out, and the set is in transmitting position.

The negative signal developed at the first transmit mixer screen is also fed to the product detector and audio output amplifier for quiet switching.

On release of the push-to-talk button, the negative bias reappears on the transmit tubes. The grid of the relay control tube returns to normal, the relay pulls in, and receiving conditions are restored.

4.5.2.3 MOX OPERATION

With the MOX switch in the MOX position, the transmitter bias line (135) is grounded directly. Switching occurs as with PUSH-TO-TALK operation. Returning the MOX switch to OFF will turn the transmitter off and put the set into receive condition.

4.5.3 FUNCTION SWITCH IN AM POSITION

The AM position of the FUNCTION switch transfers the input of the audio amplifier to the output of the AM detector. Also, disabling bias is applied to the carrier oscillator in use during receiving conditions to silence the BFO signal. In this position, the CARRIER INSERTION control is connected and bias is removed from the 6BA6 (V-10) transmit IF stage, providing full carrier insertion from 60 to 300 ma.

VOX, PTT, MOX operation functions now operate in the same manner as described under SSB (4.5.2).

4.5.4 FUNCTION SWITCH IN CW POSITION

In this position the FUNCTION switch will disconnect the VOX-PTT switch, ground the plate of the microphone preamplifier to prevent any speech information from coming through, connect the input of the audio amplifier to the output of the product detector, and connect the KEY jack to the transmitter bias line. The CARRIER INSERTION control is still connected as described in the AM position.

When the key is depressed the first time, the transmitter bias line (135) is grounded, placing the transmitter tubes and the first transmit mixer into operation. As described above under SSB operation, PUSH-TO-TALK (paragraph 4.5.2.2), the screen divider of the first transmit mixer will now actuate the relay tube through the keying diode. The relay will fall out, placing the NCX-5 into the transmitting position. From here on in, further keying is done by grid-block method, since the DELAY on the relay control tube will hold the transmit relay in for a

predetermined time. Effective break-in keying is therefore realized. The VOX-PTT circuits are disabled so that the microphone can be left in its jack. The MOX switch, however, will still actuate the transmitter.

4.5.5 FUNCTION SWITCH IN TUNE POSITION

In this position the FUNCTION switch will ground the transmitter bias line, placing the transmitter into operation, as described under "SSB-PTT Operation" (paragraph 4.5.2.2) and ground one of the balanced modulator deflection plates, providing a strong signal through the system. The MOX, VOX, PTT, and key circuits are disabled and have no influence on the tuning procedure. In this position, the center arm of the CARRIER INSERTION control is switched to the top of the control, providing an unbalanced condition. The bias on V-10 is still at zero. This provides for more than adequate drive for the tune-up condition.

4.6 RELAY FUNCTIONS:

In the foregoing discussion, the exact nature of the relay switching was not described. The six-pole double-throw relay is actuated by the plate current of the 6GH8 relay tube V8B. The NCX-5 is placed in a transmit condition when the relay is de-energized.

The first set of contacts, 5, 6, and 7, transfers +220 volts between transmit and receiving functions.

Contacts 8, 9, and 10 transfer the bias on the varactor diode in the VFO. This varactor is actuated by a bias depending on the setting and switching of the TRANSCEIVE VERNIER control during receiving periods and by a fixed bias during transmitting periods.

Contacts 11 and 12 are closed during transmit and are brought out on the rear apron of the NCX-5 for operation of the NCL-2000 linear amplifier.

Contacts 14, 15, and 16 operate as follows: The relay arm, contact 15, grounds the AGC line of the receiver at contact 14 to prevent excessive AGC build-up during transmit periods and to assure a prompt recovery of the receiver when required. Contact 15 grounds the screens of the final amplifier at contact 16, during receiving periods.

Contacts 17, 18, and 19 also are grounding contacts: the arm, contact 18 connects the meter at contact 17 to read the final cathode current during transmit periods; contact 19, grounded during receiving periods, is connected to the accessory socket for operation of the external VX-501 console.

Contacts 20, 21, and 22 ground the bias line either for receive or transmit, placing the appropriate tubes into operation as desired.

Final Output Transmit Driver Second Transmit Mixer Receiver RF Amplifier Receiver Mixer Input		3.5-4	7-7.5	14-14.5	21-21.5	28-28.5	28.5-29	29-29.5	29.5-30
Crystal Osc.		None	11	18	25	24.5	25	25.5	26
First Transmit Mixer Output First Receive Mixer Output		3.5-4	4-3.5	4-3.5	4-3.5	3.5-4	3.5-4	3.5-4	3.5-4
VFO	USB	9.5236 10.0236	10.02 9.52	10.02 9.52	10.02 9.52	9.5236 10.0236	9.5236 10.0236	9.5236 10.0236	9.5236 10.0236
	LSB	9.52 10.02	10.0236 9.5236	10.0236 9.5236	10.0236 9.5236	9.52 10.02	9.52 10.02	9.52 10.02	9.52 10.02
Carrier Osc. Second Receive Mixer Output Receiver IF	USB	6.0236	6.02	6.02	6.02	6.0236	6.0236	6.0236	6.0236
	LSB	6.02	6.0236	6.0236	6.0236	6.02	6.02	6.02	6.02

FREQUENCY CHART

FIGURE 3

SECTION 5

NCX-5 TEST AND ALIGNMENT

NOTE:

TEST AND ALIGNMENT OF THE NCX-5 SHOULD ONLY BE PERFORMED BY COMPETENT, QUALIFIED PERSONNEL.

5.1 EQUIPMENT REQUIRED:

1. Signal generator providing output at the following frequencies: 6.0218 Mc, 3.5 Mc, 4 Mc, 7 Mc, 7.3 Mc, 14.0 Mc, 14.4 Mc, 21.0 Mc, 21.5 Mc, 28.0 Mc, 28.5 Mc, 29 Mc, 29.5 Mc.
2. Vacuum tube voltmeter (VTVM).
3. Standard output meter.
4. Sweep generator capable of sweeping at approximately 60 cycles per second over a frequency range from approximately 3 to 4.5 Mc.
5. High-frequency oscilloscope covering the range from DC to 30 Mc with a maximum sensitivity of 50 mv per centimeter or better and a low capacity input probe (Tektronix type 545 with type L preamplifier or equivalent).
6. External receiver capable of receiving at 9.72 Mc.
7. 50 ohm dummy load with calibrated output meter covering the frequency range from 3.5 to 30 Mc. (A high frequency vacuum tube voltmeter with a 100 volt full scale range may be substituted for the calibrated output power meter.)
8. Power supply capable of supplying +700 volts at 300 ma, +280 volts at 200 ma and -80 volts at 6 ma.
9. 1000 cycle audio generator with an output level of 10 mv.
10. High quality microphone equipped with push-to-talk button.
11. Transmitting key.
12. Suitable alignment tools for adjustment of coils and capacitors.
13. XCU-27 crystal calibrator.

5.2 INITIAL CONTROL SETTINGS:

FRONT PANEL

RF and AF GAIN	Full cw
FUNCTION Switch	OFF
PA TUNE	Full cw
PA LOAD and EXCITER TUNE	Full ccw
BANDSWITCH	3.5 Mc
TRANSCIVE VERNIER	OFF
SIDEBAND Switch	USB
10-METER Switch	28.5 Mc
MOX-OFF Switch	OFF
VOX-PTT Switch	PTT

REAR PANEL

BIAS	Mid-range
------------	-----------

INSIDE TOP COVER

MIC GAIN	Full ccw
CARRIER INSERTION	Full ccw
VOX GAIN	Full ccw
VOX DELAY	Full ccw

Power Connections:

Connect the power supply with the 700 volt output turned off. The heater wire connecting the two 6GJ5 sockets should be removed.

5.3 IF ALIGNMENT PROCEDURE:

Turn the FUNCTION switch to CW. In a few seconds the relay should close, indicating that the NCX-5 is in a receive condition.

Connect the audio output meter to the speaker leads. This may be conveniently done by plugging the audio output meter into the phone jack. Connect the signal generator through a 1000 pF capacitor to the grid (Pin 7) of the 12BE6 (V-14) second receive mixer. Set the signal generator for output at 6.0218 Mc. A 1 to 2Kc beat note should be heard. Align the slugs of the first, second, and third IF transformers (T-4, T-5, and T-6), as well as the bottom slug of the transmit IF transformer (T-1) for maximum output, being careful to avoid overload of the receiving channel. The signal generator output should be reduced throughout this alignment procedure so that an output of 100 mw is never exceeded.

5.4 BALANCED MODULATOR ADJUSTMENT:

Connect the high-frequency oscilloscope to the grid (Pin 1) of the first IF amplifier 12BA6 (V-15). Place the MOX-OFF switch in MOX position. The relay in the NCX-5 should open, placing the unit in a transmit condition. Adjust the top and bottom slugs of transmit IF output transformer (T-1) and the slug in the Balanced Modulator transformer (T-6) for maximum indication on the scope. This should occur near mid-range on the control.

5.5 CARRIER OSCILLATOR SETTING:

Place the FUNCTION switch in the TUNE position with connections set as for balanced modulator adjustment, adjust (C-6) corresponding to the 6.0234 Mc crystal until the signal level is 0.2 volts peak-to-peak as indicated on the oscilloscope.

Set the SIDEBAND switch to LSB. Adjust (C-5) corresponding to the 6.020 Mc crystal until the signal level is 0.2 volts peak-to-peak as indicated on the oscilloscope.

Return the FUNCTION switch to SSB, return the SIDEBAND switch to USB, remove the oscilloscope connection and return MOX-OFF switch to OFF.

5.6 TRANSMITTER BANDPASS TUNING:

Connect the sweep generator to the signal grid (Pin 7) of the first transmit mixer 12BE6 (V-3). Connect the oscilloscope to the junction of C-134, R-76, and the cable feeding the grid of the second transmit mixer. Press the MOX-OFF switch to MOX. The CARRIER INSERTION control may be adjusted for minimum carrier to avoid unwanted oscilloscope indications. Adjust the top and bottom slugs of the transmit bandpass coil (T-2) for maximum display amplitude and proper response. The 3.5 and 4.0 Mc outputs of the signal generator may be used as marker frequencies. When properly aligned, the oscilloscope display should be as indicated.

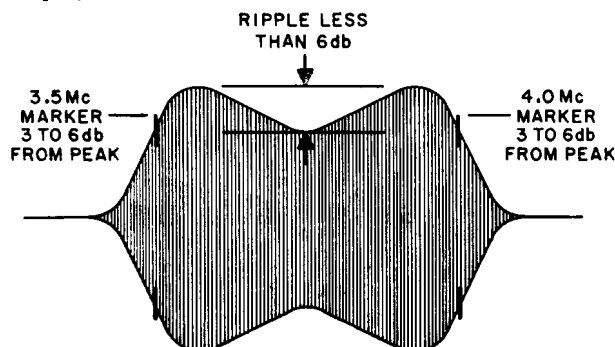

Return MOX-OFF switch to OFF and disconnect oscilloscope and sweep generator leads.

5.7 RECEIVER BANDPASS TUNING:

Connect the sweep generator to the signal grid (Pin 7) of the first receive mixer 12BE6 (V-13). Connect the oscilloscope to the signal grid (Pin 7) of the second receive mixer 12BE6 (V-14). Adjust the top and bottom slugs of the receiver bandpass coil (T-3) for maximum display amplitude and proper response similar to that obtained for the transmit bandpass coil. Disconnect the oscilloscope and sweep generator connections.

5.8 VFO FREQUENCY ALIGNMENT:

Connect the high frequency signal generator to the signal grid (Pin 7) of the first transmit mixer 12BE6 (V-13). Preset the sideband switching trimmer (C-16) and the temperature compensating trimmer (C-18) to mid-range. Set the signal generator frequency to 4 Mc. Adjust the VFO coil (L-27) for zero beat. Set the generator input to 3.5 Mc and tune the main tuning dial toward 3.5 Mc. A beat note should be obtained in the region of 3.5 Mc on the dial. If this beat note occurs at a dial setting above 3.5 Mc, the VFO trimmer (C-17) should be turned to reduce the capacity. If the beat note occurs below 3.5 Mc on the dial, increase the trimmer capacity. Return the signal generator and main tuning dial to 4 Mc. Reset the VFO coil slug for zero beat and again observe the location of the beat note near 3.5 Mc with the signal generator set to 3.5 Mc. This procedure should be repeated until the 3.5 Mc beat note and the 4.0 Mc beat note occur within 500 cycles of the dial markings.

5.9 VFO LINEARITY ADJUSTMENT:

A special linearity adjustment (consisting of two segmented plates and a stator) is incorporated in the rear section of the NCX-5 VFO capacitor. After adjustment of the VFO frequency at 4.0 and 3.5 Mc, it may be necessary to set the VFO linearity.

Insert the crystal calibrator into the crystal calibrator socket. With the crystal calibrator turned on and set for 100 Kc markers, it should be possible to obtain a zero beat at the 3.5 and 4.0 Mc points which have previously been set. The main tuning should now be adjusted to 3.9, 3.8, 3.7, and 3.6 Mc. At each of these points zero beat should occur within ± 500 cycles of the exact dial frequency. If necessary, one (or both) of the segmented adjusting plates should be bent as required to achieve proper calibration. If the indicated frequency is too low at the zero beat point, one or both of the plates should be moved toward the stator. If the indicated dial reading at zero beat is too high, the plate should be moved away from the stator. It is important that this linearity correction be made on a gradual basis. The entire correction at any one point should not be made with a single segment of the correction plate. When properly aligned, the corrector segments will lie in a smooth curve.

5.10 VFO SIDEBAND SWITCHING ADJUSTMENT:

Set the main tuning to zero beat at 3.8 Mc, rotate the sideband selector switch to LSB. The frequency obtained should still be zero beat. If it is not, set the sideband trimmer (C-16) for zero beat. As the sideband selector switch is rotated from LSB to USB, there should be no change of frequency. There is a small interaction of this adjustment with the VFO alignment. The VFO alignment should be readjusted if any error is introduced.

5.11 TEMPERATURE COMPENSATING ADJUSTMENT:

During alignment of the NCX-5, its VFO should be checked. If drift is excessive, the temperature compensating capacitor should be adjusted to provide greater or less compensation. Drift towards a lower dial reading on 80 meters indicates excessive temperature compensation and the compensating trimmer (C-18) should be turned to reduce capacity. A drift toward a higher dial reading indicates insufficient compensation and the trimmer should be turned for greater capacity. Adjustment of the compensating trimmer will change the VFO frequency. Complete realignment of the VFO can be avoided by the following procedures: Set the NCX-5 to zero beat at the 3.8 Mc dial setting. Adjust the compensating trimmer as required and immediately adjust the VFO trimmer (C-17) to return the NCX-5 to zero beat. If this procedure is carefully followed, the dial calibration should not be seriously affected. If a major correction has been made, the dial calibration should be checked and the alignment of the preceding sections should be repeated if necessary. Disconnect the signal generator leads from the NCX-5.

5.12 TRANSMIT MIXER AND DRIVER ALIGNMENT:

Connect the high-frequency oscilloscope to the junction of C-46, R-42, and the grids of the 6GJ5 final amplifier. Set the BAND switch to 3.5 Mc and the FUNCTION switch to TUNE. The relay should again drop out, indicating that the unit has been placed in a transmit condition. Set the main tuning dial to 3.750 Mc and the EXCITER control to 5. Adjust the 80 meter mixer coil (L-10) and the 80 meter driver coil (L-5) slugs for maximum indication on the oscilloscope. When the slugs are properly adjusted, the peak-to-peak output voltage on the oscilloscope should exceed 130 volts.

Set the BAND switch to 7.0 Mc and the EXCITER TUNE control to 6. Repeat the above procedure at 7.300 Mc while adjusting the 40 meter mixer coil (L-9) and the 40 meter driver coil (L-4). An output of more than 130 volts peak-to-peak must be indicated on the oscilloscope.

At this point a ripple will appear on the oscilloscope pattern. Adjust the harmonic trap (L-29) to minimize this ripple. After this adjustment is made, there will be some interaction with the tuning of the 40 meter mixer coil (L-9) which must be readjusted for maximum amplitude. Repeat these adjustments until minimum ripple and maximum amplitude are obtained simultaneously. The setting of the harmonic trap may be checked by removing the 11 Mc crystal in the high-frequency oscillator circuit. When the crystal is removed, there should be a large drop in the amplitude of the oscilloscope display. If there is no such drop, the harmonic trap has been mistuned and the slug should be withdrawn from the coil and the above alignment procedure repeated on the proper trap frequency.

Set the BAND switch to 14.0 Mc and the EXCITER TUNE control to 3. Repeat the above procedure at 14.250 Mc while adjusting the 20 meter mixer coil (L-8) and the 20 meter driver coil (L-3).

Set the BAND switch to 21.0 Mc and the EXCITER TUNE control to 7. Repeat the above procedure at 21.250 Mc while adjusting the 15 meter mixer coil (L-7) and the 15 meter driver coil (L-2).

Set the BAND switch to 28.5 Mc and the EXCITER TUNE control to 7. Repeat the above procedure at 28.750 Mc while adjusting the 10 meter mixer coil (L-6) and the 10 meter driver coil (L-1).

5.13 FINAL AMPLIFIER PRELIMINARY ADJUSTMENT (10 METER):

The NCX-5 construction does not provide for any alignment of the final amplifier. It is necessary at this time to check the final amplifier for proper operation at the high and low ends of all bands. In addition, it is necessary to make a slight final adjustment on the driver plate coils and on the neutralizing capacitor. These checks should be made in the following sequence: Connect the heater wire between the 6JB6 sockets. Place the FUNCTION switch in the CW position and allow approximately 30 seconds for warm-up of the final amplifier tubes.

— CAUTION —

UP UNTIL THIS TIME, THERE HAS BEEN NO POWER APPLIED TO THE FINAL AMPLIFIER. ALL CIRCUITS WHICH HAVE BEEN OPERATING AND WHICH HAVE BEEN TESTED ARE LOW LEVEL CIRCUITS USING VOLTAGES AND POWER NORMALLY ENCOUNTERED IN DAY-TO-DAY RECEIVER WORK. FROM HERE ON, VOLTAGES AND CURRENTS MAY BE ENCOUNTERED WHICH ARE DANGEROUS TO PERSONNEL AND TO THE TEST EQUIPMENT AND THE UNIT UNDER TEST. IT IS ESSENTIAL TO BE SURE THAT NO PIECE OF TEST EQUIPMENT BE MISCONNECTED INTENTIONALLY OR ACCIDENTALLY TO THE NCX-5. IT IS FURTHER

IMPORTANT THAT PERSONNEL BE CAUTIONED AGAINST CARELESS HANDLING WHICH MAY RESULT IN CONTACT WITH DANGEROUS VOLTAGES. IT IS FURTHER IMPORTANT THAT THE NCX-5 NOT BE PLACED INTO A TRANSMITTING CONDITION WITHOUT PROPER TUNING, SINCE DAMAGE MAY RAPIDLY RESULT TO THE NCX-5. IN A NUMBER OF THE FOLLOWING TESTS THE TRANSMITTER WILL BE OPERATED AT FULL POWER OUTPUT. IF MISINDICATIONS ARE OBTAINED, OR IF THE TEST IS NOT COMPLETED WITHIN A PERIOD OF 15 SECONDS, OR IF THE UNIT IS NOT TUNED UP WITHIN A PERIOD OF 15 SECONDS, IT IS IMPORTANT THAT THE UNIT BE RETURNED TO A RECEIVING CONDITION. OTHERWISE, SERIOUS AND PERMANENT DAMAGE CAN BE DONE TO THE FINAL AMPLIFIER TUBES AND COMPONENTS IN THE FINAL OUTPUT CIRCUIT.

Disconnect all test equipment from the NCX-5. Attach the 50 ohm dummy load with calibrated output meter to the NCX-5 antenna terminals. With a D.C. voltmeter, set the bias at the grid of the final amplifier for maximum negative voltage. With the BAND switch still on the 28.5 Mc band, set the main tuning dial to 28.75 Mc. Now turn the FUNCTION switch to TUNE and rapidly peak the EXCITER TUNE for maximum meter reading on the combination S-meter and cathode current meter. Adjust the 10 meter driver plate coil (L-1) for maximum meter reading while slowly rocking the EXCITER TUNE control. This will correct for the presence of the oscilloscope probe in the previous setting. Now rotate the PA TUNE control and observe whether a dip occurs in the plate current reading.

Note the power output recorded by the power output meter. This power output should exceed 100 watts at all frequencies providing the PA LOAD control is adjusted so that the final amplifier draws 300 ma. With the PA TUNE control set for a plate current dip, the PA LOAD control is slowly rotated in a clockwise direction. As the PA LOAD control is advanced, it will be necessary to slightly retune the PA TUNE control to stay in the dip. Continue this process until the minimum reading in the dip corresponds to 300 ma on the meter.

5.14 NEUTRALIZING CAPACITOR:

With the FUNCTION switch in the TUNE position, rotate the PA TUNE control to either side of the resonant point and observe the plate current meter. It is necessary that the off resonance current exceed 350 ma. Having noted the off resonance plate current, retune the PA TUNE control to the plate current dip at 300 ma and observe the power output. It should exceed 100 watts. Carefully rotate the PA

TUNE control to either side of the dip and observe whether the power output rises or falls. With a proper setting of the neutralizing capacitor, the power output should fall to either side of the dip. If the power output actually rises as the tuning control is tuned away from the dip, it will be necessary to adjust the neutralizing capacitor. This can be quickly done on a trial and error basis by rotating the neutralizing capacitor and observing whether maximum power output occurs at the plate current dip. As proper neutralization is achieved, maximum power output will occur at minimum plate current. Return the FUNCTION switch to CW.

5.15 FINAL AMPLIFIER PRELIMINARY ADJUSTMENT (80-15 METERS):

Set the BAND switch to 21 Mc and the main tuning dial to 21.250 Mc. Turn the FUNCTION switch to TUNE and rapidly peak the EXCITER TUNE for maximum meter reading. Adjust the 15 meter driver plate coil (L-2) for maximum meter reading while slowly rocking the EXCITER TUNE control. This will correct for the presence of the oscilloscope probe in previous tests. Now rotate the PA TUNE control and observe whether a dip appears in the reading. Advance the PA LOAD in a clockwise direction and slightly retune the PA TUNE control to stay in dip. Continue this process until the minimum meter reading in the dip corresponds to 300 ma. The power output should exceed 100 watts and proper neutralization should be observed.

Repeat this procedure at the following BAND switch and tuning settings, in each case adjusting the proper driver coil for maximum meter indication while rocking the EXCITER TUNE control.

MAIN		
BANDSWITCH	TUNING DIAL	DRIVER COIL
14 Mc	14.250 Mc	L-3
7 Mc	7.250 Mc	L-4
3.5 Mc	3.750 Mc	L-5

5.16 FINAL AMPLIFIER TUNING CHECKS:

The proper crystal should be inserted into the NCX-5 high frequency oscillator for operation at BAND switch settings of 28, 29, and 29.5 Mc. If these crystals are not available, final amplifier tuning checks in these BAND switch settings cannot be made.

Set the BAND switch to 28.0 Mc. Set the main tuning dial to 28.250 Mc. Turn the FUNCTION switch to TUNE and peak the EXCITER TUNE for maximum meter reading. Rotate the PA TUNE control and observe whether a dip appears in the reading. Advance the PA LOAD control in a clockwise direction and retune the PA TUNE control to maintain the output circuit in the dip. Continue this procedure until the minimum reading in the dip corresponds to 300 ma on the meter. Power output at this setting should exceed 100 watts and proper neutralization should be observed.

Repeat this check with BAND switch and main tuning capacitor set for the following frequencies. If necessary, mixer and driver coils may be slightly re-adjusted to maintain proper tracking across the band providing sufficient drive and proper final amplifier operation is achieved.

BANDSWITCH	MAIN TUNING DIAL
29 Mc	29.25 Mc
29.5 Mc	29.75 Mc
21.0 Mc	21.00 Mc
21.0 Mc	21.50 Mc
14.0 Mc	14.00 Mc
14.0 Mc	14.50 Mc
7.0 Mc	7.00 Mc
7.0 Mc	7.30 Mc
3.5 Mc	3.50 Mc
3.5 Mc	4.00 Mc

5.17 LOCAL OSCILLATOR CRYSTAL ADJUSTMENT:

Set the BAND switch to 7.0 Mc. Turn the crystal calibrator ON. Tune to any crystal calibrator signal. The dial should read an exact 100 Kc point. Two beat notes may be noted. Adjust the 11 Mc crystal trimmer (C-9) and the main tuning dial to set both beat notes to zero.

Repeat this procedure on the 14.0 Mc band and set the 18 Mc crystal trimmer (C-10).

Repeat this procedure on the 21.0 Mc band and set the 25 Mc crystal trimmer (C-11).

The accessory crystal trimmers may also be set by this procedure according to the following chart:

BAND-SWITCH	10 METER SEGMENT SWITCH	CRYSTAL FRE-QUENCY	CRYSTAL TRIM-MER
28.0 Mc	28.0 Mc	24.5 Mc	C-14
28.0 Mc	29.0 Mc	25.5 Mc	C-13
28.0 Mc	29.5 Mc	26 Mc	C-12

5.18 PARASITIC CHECK:

Set the FUNCTION switch to SSB. Press the MOX-OFF switch to MOX. Adjust CARRIER BALANCE control for minimum current. Tune PA TUNE, PA LOAD, and EXCITER controls through their ranges. Look for unwanted spurious peaks on the meter. There should be none. Repeat this test on all bands.

5.19 CARRIER SUPPRESSION, SIDEBAND SUPPRESSION, MODULATION, AND ALC CHECKS:

Connect the audio generator to the microphone jack and supply 10 mv of audio signal to the NCX-5. Rotate the FUNCTION switch to the TUNE position. Connect the high-frequency oscilloscope to the antenna line which is connected to the dummy load. Tune the final amplifier for maximum output at 300

ma input as described in the previous sections. A level well in excess of 100 volts peak-to-peak should be noted on the oscilloscope. Turn the FUNCTION switch to the SSB position. Set the carrier balance control for minimum indication on the oscilloscope which should correspond to minimum indication on the meter. Adjust the BIAS control for 60 ma on the meter. The level remaining on the oscilloscope should not exceed 0.5 volt peak-to-peak, thus insuring carrier suppression better than 50 db. If necessary, carefully adjust the balanced modulator phase trimmer (C-7) for minimum indication while rocking the carrier balance control through minimum until the required 0.5 volt level is obtained.

Now rotate the MIC GAIN control slowly in a clockwise direction. A signal should again appear on the oscilloscope. The MIC GAIN should be advanced until the cathode current meter reads 250 ma. Output at the scope should be 120-180 volts. The wave form at this point should appear as indicated in figure 6A. It is necessary to note the level of ripple on the wave form to total wave form level. The ripple should not exceed 1/50 of the total wave form. This indicates that the unwanted sideband suppression with a 1000 cycle tone is in excess of 34 db.—the limit of this measuring technique.

It is important to note the difference between carrier balance and unwanted sideband suppression in the previous measurement. If the carrier balance control is rotated slightly, the wave form of figure 6A will be altered to the wave form of figure 6B. If this wave form is present while attempting to make the sideband suppression measurement, the carrier balance control should be slightly adjusted to compensate and return the picture to that to figure 6A.

Place the FUNCTION switch in the AM position. Now further advance the MIC GAIN until the meter just reaches 300 ma as set by our previous tune-up procedure. Note the oscilloscope level. Slowly advance the CARRIER INSERTION control cw from the minimum setting. As this occurs, the wave form will begin to develop large cusps and peaks which will tend to exceed the noted oscilloscope level. Slowly reduce the MIC GAIN to keep the peaks at the predetermined level by carefully adjusting both the MIC GAIN and the CARRIER INSERTION control. It should be possible to obtain a picture as illustrated in figure 6C. It is important that the peaks of this figure be at exactly the level determined with the balanced carrier at 300 ma of cathode current. This is equivalent to a two-tone test and is useful in indicating distortion in the transmitter channel and performance of the modulating circuits. The wave form which is observed should have a clean sharp cusp and should have a sine wave envelope. There should be no flattening of the peaks and no broadening of the cusps. Typical in correct wave forms are indicated in figure 6D & 6E.

Advance the MIC GAIN control to maximum and readjust the CARRIER INSERTION control for sharp cusps. The final amplifier should now be overdriven and ALC voltage should result. The oscilloscope wave form should remain as shown in figure 6C. Check the ALC output at the junction of D-9, R-34, R-35, and C-48. There should be approximately -5 volts at this point. Check the ALC voltage at the junction of D-8, D-9, and C-50. The voltage at this point should be 1/2 of the previous reading. This checks the action of the internal ALC circuit.

The rear ALC jack may now be checked by applying -10 to -15 volts at the ALC input jack. The oscilloscope display amplitude should decrease, indicating external control.

Press the MOX-OFF switch to OFF and set the VOX-PTT switch to PTT.

If all of the tests are met satisfactorily, we can assume that the transmitter is working properly, although it is of some value to check the dynamic operation of the transmitter on the microphone. To do this, return the MIC GAIN to zero and place the FUNCTION switch in the SSB position. Now remove the audio generator from the microphone jack and replace it with the test microphone. Press the push-to-talk button and speak normally into the microphone. Slowly advance the MIC GAIN control until the peaks of the resulting signal reach the amplitude used for the previous two-tone type of test. At this point, the meter will be fluctuating rapidly with the speech content. The meter should generally average around 125 ma of current and the output wave form should appear as illustrated in figure 6F.

5.20 TRANSMIT-RECEIVE FREQUENCY CHECK:

Set the BAND switch to 3.5 Mc and the dial to 3.700 Mc. Tune the final amplifier using the TUNE function. Return the FUNCTION switch to CW and press the MOX-OFF switch to MOX. Return the MIC GAIN control to the full ccw position. Now rotate the CARRIER INSERTION control until 300 ma is indicated on the meter and output appears on the oscilloscope. Press the MOX-OFF switch OFF. Tune an accessory receiver to 9.72 Mc and couple lightly to the NCX-5 VFO. A beat note should be noted. Press the MOX-OFF switch to MOX. The

beat note indicated by the accessory receiver should not change more than 50 cycles. Press the MOX-OFF switch OFF.

5.21 LSB-USB SWITCHING CHECK:

Proper sideband switching may be easily checked with the D.C. voltmeter according to the chart below.

5.22 SWITCHING TESTS:

The transmitter portion of the NCX-5 is presently connected to a dummy load with an oscilloscope. Tune the NCX-5 to resonance for maximum power output. Balance the carrier. With these conditions established, now check the entire switching sequence in the following manner:

1. Place the FUNCTION switch in SSB, the PTT-VOX switch in the PTT position, and MOX-OFF switch OFF. Press the push-to-talk button and speak into the microphone. A standard single sideband output should appear on the oscilloscope. Release the push-to-talk button. The NCX-5 should revert to receive.
2. Press the MOX-OFF switch to MOX and speak into the microphone. SSB output should result. Return the MOX-OFF switch OFF and the NCX-5 should revert to receive.
3. Place the VOX-PTT switch in the VOX position. While speaking into the microphone, slowly advance the VOX GAIN control until the relay trips the unit into transmit. Stop speaking and the transceiver should return to receive.
4. While speaking into the microphone to cause the NCX-5 to transmit, adjust the DELAY control full ccw, stop speaking, and the NCX-5 should go back to receive in approximately 1/10 of a second.
5. Turn the DELAY control full cw and speak into the microphone. The NCX-5 should switch to transmit; stop speaking and the NCX-5 should return to receive in one second. In each case, a standard single-sideband signal should be observed on the

TEST POINT	LSB					USB					
	BAND	3.5	7.0	14.0	21.0	28.0	3.5	7.0	14.0	21.0	28.0
1		+150	-35	-35	-35	+150	-35	+150	+150	+150	-35
2		-80	0*	0*	0*	-80	0*	-80	-80	-80	0*
3		0*	-80	-80	-80	0*	-80	0*	0*	0*	-80

*SHOULD BE -40 WITH AM RECEIVE CONDITION ONLY

Test Point Location:

1. J7, Pin 3 (Calibrator Socket)
2. Junction of R-65 and C-153
3. Junction of R-61 and C-64

- oscilloscope while speaking into the microphone.
6. Set the FUNCTION switch to AM and repeat the above tests for PTT, VOX, and MOX operation.
 7. While speaking into the microphone, increase the CARRIER INSERTION control from minimum and observe the introduction of carrier into the sideband signal on the oscilloscope.
 8. Place the FUNCTION switch in the CW position. Advance the VOX GAIN control full cw (maximum sensitivity). Speaking into the microphone in this condition should not result in transmit-receive switching.
 9. Set the VOX-PTT switch to PTT and press the PTT button. The NCX-5 should not switch into transmit.
 10. Press the MOX-OFF switch to MOX. The NCX-5 should switch to transmit. Return the MOX-OFF switch to OFF.
 11. Insert a key into the key jack. A tap of the key should place the NCX-5 into a transmit condition. Upon release of the key, the unit should revert to receive in 1/10 of a second to one second, depending on the setting of the VOX DELAY control.
 12. Hold the key closed, speak into the microphone and advance the MIC GAIN control. There should be no evidence of modulation on the oscilloscope.
 13. Set the transmitting key for a long series of dots. Adjust the CARRIER INSERTION control for transmitter output just below full power. Observe the series of keying pulses on the high-frequency oscilloscope. A proper keying pulse should appear as in figure 6G. Figure 6H and 6I indicate improper keying sequences.
 14. Set the FUNCTION switch to TUNE. Observe that full power output is attained on the oscilloscope. Adjust the CARRIER INSERTION control. There should be no change in the output signal.
 15. Speak into the microphone and advance the MIC GAIN control. There should be no evidence of modulation on the oscilloscope.
 16. Return the FUNCTION switch to SSB.

5.23 TRANSCEIVE VERNIER:

Set the NCX-5 to 3.700 Mc. Tune the accessory receiver to 9.72 Mc and lightly couple to the NCX-5 VFO. Observe that the beat note may be varied more than ± 5 Kc with the TRANSCEIVE VERNIER. Press the MOX-OFF switch to MOX. Observe that the beat note cannot be varied with the TRANSCEIVE VERNIER and that it corresponds to the beat note previously heard with the MOX-OFF switch OFF and the TRANSCEIVE VERNIER at mid-range. Turn the TRANSCEIVE VERNIER OFF and observe that the beat note does not change. Return the NCX-5 to receive.

Disconnect all test equipment.

— CAUTION —

IN THE FOLLOWING SERIES OF TESTS, THERE IS NO LOAD ON THE TRANSMITTER OUTPUT. IF THE UNIT SHOULD GO INTO TRANSMIT UNDER THIS CONDITION, SERIOUS DAMAGE CAN BE DONE TO THE FINAL OUTPUT STAGE. ALSO DURING THIS SERIES OF TESTS, A SIGNAL GENERATOR WILL BE CONNECTED TO THE ANTENNA TERMINALS. SERIOUS DAMAGE CAN BE DONE TO THIS SIGNAL GENERATOR IF THE UNIT IS ACCIDENTALLY PLACED INTO TRANSMIT.

5.24 ANTI-VOX CHECK:

Connect the signal generator to the antenna terminals through a suitable dummy load to match the 50 ohm input impedance. Set the signal generator for 4.0 Mc, the BAND switch to 3.5 Mc, and the main tuning dial to 4.0 Mc until a beat note is obtained at a frequency of approximately 1000 cycles. Connect the power output meter to the audio output terminals by use of the phone jack. Set the AUDIO GAIN control for approximately $\frac{1}{2}$ watt. Measure the D.C. voltage at the junction of D3, R103, R107, and C157. A voltage of more than +10 volts should be indicated at this test point.

5.25 VFO JACK:

Connect 100 ohms from the VFO jack to ground. The beat note should disappear, indicating that the VFO is not functioning. Feed an external signal into the VFO jack between 9.52 and 10.02 Mc. It should be possible to retune the beat note with the external signal. Remove the external signal and the 100 ohm resistor. The original beat note should reappear.

TOP VIEW

FIGURE 4

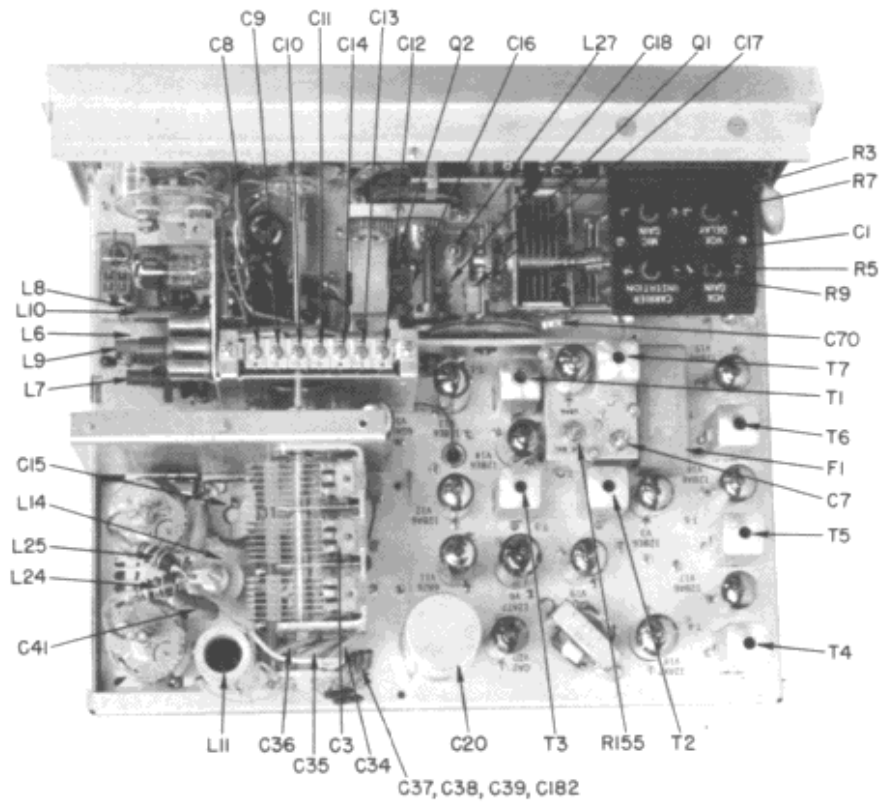

BOTTOM VIEW

FIGURE 5

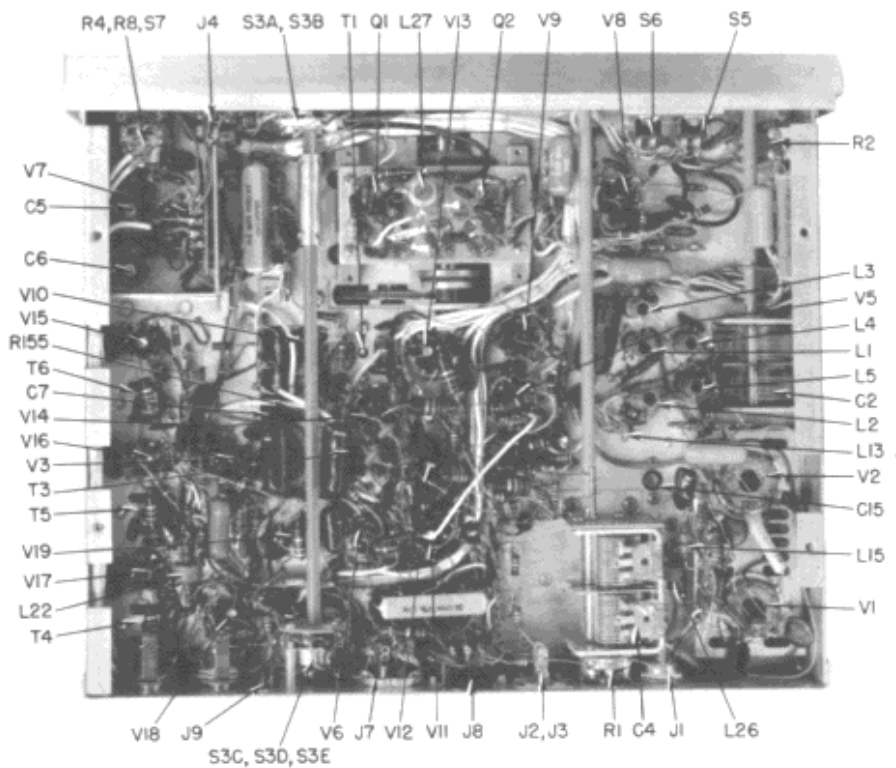

NCX-5 WAVE FORMS

FIGURE 6

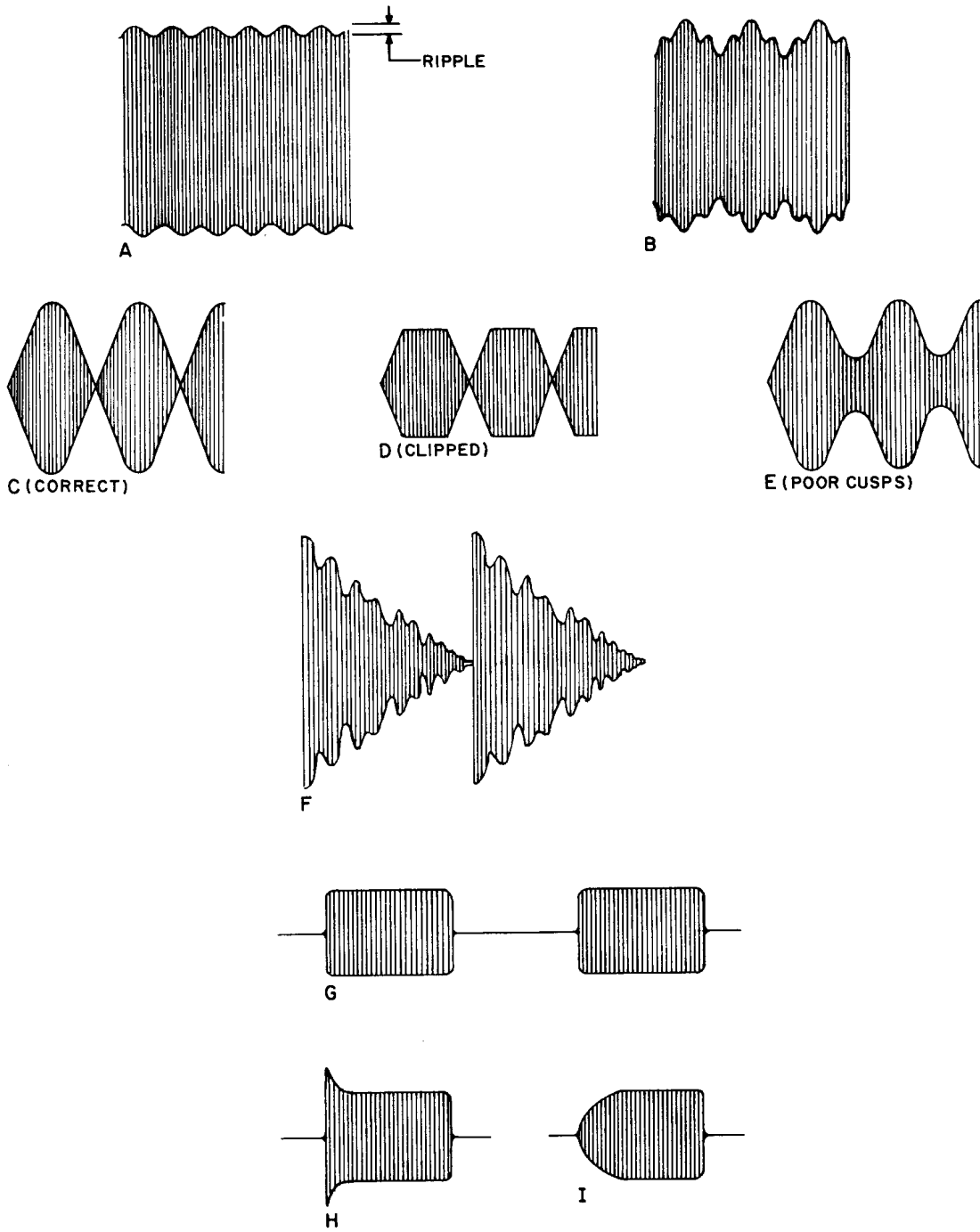

SECTION 6 PARTS LIST

SOCKETS AND JACKS

J1	Antenna	A51479
J2, J3	Ext. VFO In, Ext. ALC In	A51084
J4	MIC	A50793-2
J5	Key	A50793-1
J6	Phones	A50793-3
J7	Octal	B27674-1
J8	Jones Male	A50791
	Jones Female	A50828
J9	Relay Terminal Strip	A51563
	Relay Socket	A50954
	Novar	A50802
	9 Pin	B27668-1
	7 Pin	B27669-3
	Transistor	A50981
	Xtal	A50799
	Panel Lamp, Counter	A51607
	Panel Lamp	B50829-2

POTENTIOMETERS AND CONTROLS

R1	BIAS	B50541-1
R2	S-METER	B50541-3
R3	MIC GAIN	B50541-9
R4, R8	RF GAIN – AUDIO GAIN – CAL SWITCH	B51550
R5	VOX GAIN	B50541-2
R6	TRANSCEIVE VERNIER and SWITCH	B50986-2
R7	VOX DELAY	B50541-4
R9	CARRIER INSERTION	B50541-1
R155	CARRIER BALANCE	A51847

RESISTORS

R38	1.5 K 2% ½ W	RS 20BF-152G
R39	3.2 ohm 3% 2W WW	B517436-10
R52, R109	10.0 K Film	A51559-3
R108, R114	2.2 K Film	A51559-2
R110	470 ohm Film	A51559-1
R111	33.0 K Film	A51559-4
R113	470 K Film	A51559-5

TRIMMERS

C5, C6, C7	PISTON 1–8	A51766
C17, C18	CERAMICON 5 25 NPO	B51852-0
C7	Mica, Balance	A50137
C8, C9, C10, C11, C12, C13, C14	Mica Assembly	B50993-6

TRIMMERS (Cont)

C15	Air, Neutralization	B50364
C16	Ceramicon 1.5 – 7 NPO	B51852-2

CAPACITORS

C1	Gang: VFO - (Main) Tuning	C51507
C2	Gang: EXCITER TUNE	C50790-2
C3	Gang: PA TUNE	C50789-2
C4	Gang: PA LOAD	C50788
C20	Electrolytic	C19458-6
C34	Ceramic 82 pF 5% NPO spec. rating	A50849-4
C35	Ceramic 51 pF 5% NPO spec. rating	A50849-2
C36, C40	Ceramic 75 pF spec. rating	A50849-3
C41, C47	Ceramic 500 pF spec. rating	A50849-5
C70	Ceramic 5pF N220	CC 20 RH 050 K
C165	Ceramic 10 pF N750	CC 20 UJ 100 K
C166	Ceramic 47 pF N750	CC 20 UJ 470 K
C181	Ceramic 120 pF OTC Special	A50113-2

TRANSFORMERS

T1	TRANSMIT IF	B50764
T2, T3	Bandpass 3.5 to 4.0 Mc	B51513
T4, T5, T6	IF 6.02 Mc	B50766
T7	BALANCED MODULATOR TRANSFORMER	B51821
T8	AUDIO	B19435-3

COILS AND CHOKES

L1	10 Meter Driver	B51517
L2	15 Meter Driver	B51515
L3	20 Meter Driver	B50759
L4	40 Meter Driver	B50757
L5	80 Meter Driver	B50755
L6	10 Meter Mixer	B51516
L7	15 Meter Mixer	B51514
L8	20 Meter Mixer	B50760
L9 and L29	40 Meter Mixer	B51581
L10	80 Meter Mixer	B50756
L11	Final Tank	B51518
L12	Choke, Special	B51554
L13, L16, L17, L19, L20, L21, L23	Choke, 220 µh	A50206-1
L14	p. a. Choke	R154 NCL
L15	Choke, Final Grid 100 µh	NCL R33
L18	Choke 10 µh	C50527-8

COILS AND CHOKES (Cont)

L22	Choke 4.7 μ h	C50523-5
L24, L25	Choke, Parasitic	B51545
L26	Choke, Antenna	C50523-3
L27	Coil VFO	B51520
L28	Choke VFO 3.3 μ h	R1550-19

SWITCHES

S1-A	Bandswitch, SB Interlock, VFO	A51524
S1-BC	Bandswitch, SB Interlock, Carrier Osc.	A51522
S1-DE	Bandswitch, Mixer Output	A51521
S1-FG	Bandswitch, Driver Output	A51525
S1-HI	PA Bandswitch	A51523
S1	Detent	B51558
S1	Shaft	A50854
S2	Sideband Selector	B51526
S3-AB	Function Switch, Front	B51817
S3-CDE	Function Switch, Rear	B51541
S4	10 Meter Switch	B51549
S5	Rocker MOX-OFF	B51548-2
S6	Rocker VOX-PTT	B51548-1
S7	Part of Gain Control	B51550
S8	Part of Transceive Vernier	B50986-2

KNOBBS

Function, Sideband Selector, Bandswitch	NPS-7K2LA
PA Load, Exciter Tune, Transceive Vernier	NPS-7F2LA
PA Tune	NPS-7N1LC
Main Tuning	NPS-17D2LA
Audio Gain	NPS-7N3LC
Lever, RF Gain, 10 Meter Switch	A51399

SHAFTS, COUPLINGS, DRIVE TRAIN

Shaft, Function Switch	A51551
Shaft, PA Tune	A51561-1
Shaft, Exciter Tune	A50818-2
Shaft, PA Load	A50818-3

SHAFTS, COUPLINGS, DRIVE TRAIN (Cont)

Coup-Link	B25000
Bushing, Panel	A50840-0
Palnut 3/8-32	B19322-8
Coupling, Function Switch	J654-2
Coupling, Bandswitch	A12611
Drive Train, VFO, With Counter, Without Gang	A51681

COVERS

Cover, PA	C50815
Cover, VFO Top	B51560
Cover, VFO Bottom	B51587
Cover, Second Mixer	C51505

MISCELLANEOUS PARTS

Front Panel	E51502-5
Bushing, Hanger	A50817
Nuts for Above	A50117-7
Lockwasher for Above	5/8 KCE
Hanger Bracket	B50836
Hanger Screws	B50835
Cabinet	E51580-2
Foot, Rubber, Extension	A50850
Foot, Rubber	A50851
Cabinet Cover	D51579-3

MISCELLANEOUS ELECTRICAL

M	Meter	C50833
F-1	Filter, Xtal	A51557
D-2	Diode, Varactor	A51307-9
X1	Xtal, 6.0200 Mc	A51822-1
X2	Xtal 6.0234 Mc	A51822-2
X3	Xtal 11.000 Mc	A51555-1
X4	Xtal 18.000 Mc	A51555-2
X5	Xtal 25.000 Mc	<u>A51555-4</u>
X6	Xtal 26.000 Mc	<u>A51555-6</u>
X7	Xtal 25.500 Mc	A51555-5
X8	Xtal 24.5 Mc	A51555-3
Rel	Relay 6PDT 8000 ohms	A50798

SECTION 7

VOLTAGE AND RESISTANCE MEASUREMENTS

THE FOLLOWING DC VOLTAGE MEASUREMENTS ARE TAKEN WITH A VTVM WITH AN INPUT RESISTANCE GREATER THAN 10 MEGOHMS. RECEIVE VOLTAGES ARE TAKEN AT MAXIMUM RF GAIN WITH NO SIGNAL INPUT. TRANSMIT VOLTAGES ARE TAKEN WITH CARRIER BALANCE TUNED FOR MINIMUM INDICATION AND FUNCTION SWITCH IN THE SSB POSITION.

Tube	Type	Function	Pin	Resistance	Voltage	
					Receive	Transmit
V-1	6JB6	FINAL AMPLIFIER	1	10 k	0	+250
			2	20 k	-45 to -65 V ADJUSTABLE WITH BIAS CONTROL	
			3	3.2 Ω	0	.3 V
			4	—	12.6*	12.6
			5	—	6.3*	6.3*
			6	20 k	-45 to -65 V ADJUSTABLE WITH BIAS CONTROL	
			7	10 k	0	+250
			8	0	0	0
			9	0	0	0
V-2	6JB6	FINAL AMPLIFIER	1	10 k	10 k	270
			2	20 k	-45 to -65 V ADJUSTABLE WITH BIAS CONTROL	
			3	3.2 Ω	0	0
			4	—	6.3*	6.3*
			5	—	0	0
			6	20 k	-45 to -65 V ADJUSTABLE WITH BIAS CONTROL	
			7	10 k	0	270
			8	0	0	0
			9	0	0	0
V-3	12BE6	FIRST TRANSMIT MIXER	1	100 k	-40	0
			2	0	0	0
			3	0	0	0
			4	—	12.6*	12.6*
			5	—	240	270
			6	30 k	240	30
			7	100 k	-40	0
V-4	6KE8	LOCAL OSCILLATOR AND SECOND TRANSMIT MIXER	1	10 k	150	150
			2	200 k	-40	0
			3	100 k	270	170
			4	0	0	0
			5	—	6.3*	6.3*
			6	15 k	270	260
			7	0	0	0
			8	0	0	0
			9	47 k	-1	-1
V-5	6GK6	DRIVER	1	150 Ω	0	8
			2	200 k	-40	0
			3	0	0	0
			4	—	6.3*	6.3*
			5	—	12.6*	12.6*
			6	INF.	0	0
			7	10 k	300	300
			8	10 k	250	270
			9	0	0	0
V-6	12AT7	SPEECH AMPLIFIER AND S-METER AMPLIFIER	1	20 k	0	85
			2	30 Ω	0	0
			3	1 k	0	1
			4	0	0	0
			5	0	0	0
			6	35 k	250	0
			7	56 k	.2	6
			8	0	3	0
			9	—	6.3*	6.3*

*AC OR DC DEPENDING ON SUPPLY

VOLTAGE AND RESISTANCE MEASUREMENTS (Cont)

Tube	Type	Function	Pin	Resistance	Voltage	
					Receive	Transmit
V-7	12AU7	CARRIER OSCILLATOR	1	20 k	100	100
			2	300 k	0 LSB, -60 USB	0 USB, -60 LSB
			3	0	0	0
			4	—	12.6*	12.6*
			5	0	0	0
			6	20 k	100	100
			7	300 k	0 USB, -60 LSB	0 USB, -60 LSB
			8	0	0	0
			9	—	6.3*	6.3*
V-8	6GH8	MICROPHONE PREAMPLIFIER AND RELAY CONTROL	1	20 k	150	300
			2	1 meg	-1	-1
			3	600 k	35	35
			4	—	6.3*	6.3*
			5	—	12.6*	12.6*
			6	100 k	100	-.9
			7	0	0	0
			8	0	0	0
			9	1.5 meg	0	-40
V-9	12AU7	VOX AMPLIFIER	1	100 k	70	80
			2	800 k	0	0
			3	1.5 k	3	3
			4	0	0	0
			5	—	12.6*	12.6*
			6	100 k	35	40
			7	10 meg	-.7	-.7
			8	0	0	0
			9	—	6.3*	6.3*
V-10	6BA6	TRANSMIT IF	1	2.5 k	0	4
			2	150 k	0	200
			3	0	0	0
			4	—	6.3*	6.3*
			5	20 k	0	210
			6	15 k	0	65
			7	330 Ω	0	3
V-11	6BZ6	1st RF STAGE	1	1 meg	0	0
			2	220 Ω	+1	0
			3	—	6.3*	6.3*
			4	—	12.6*	12.6*
			5	10 k	300	300
			6	80 k	150	0
			7	0	0	0
V-12	12BE6	2nd RF STAGE	1	470 k	0	0
			2	0	0	0
			3	0	0	0
			4	—	12.6*	12.6*
			5	15 k	270	250
			6	82 k	130	0
			7	270 Ω	2.7	0
V-13	12BE6	1st RECEIVER MIXER	1	150 k	-.5	-40
			2	0	0	0
			3	0	0	0
			4	—	12.6*	12.6*
			5	10 k	250	250
			6	56 k	200	0
			7	10 Ω	0	0

*AC OR DC DEPENDING ON SUPPLY

VOLTAGE AND RESISTANCE MEASUREMENTS (Cont)

Tube	Type	Function	Pin	Resistance	Voltage	
					Receive	Transmit
V-14	12BE6	2nd RECEIVER MIXER	1	120 k	0	-40
			2	0	0	0
			3	0	0	0
			4	—	12.6*	12.6*
			5	10 k	250	250
			6	56 k	25	0
			7	120 k	0	-40
V-15	12BA6	1st IF STAGE	1	40 k	0	0
			2	0	0	0
			3	0	0	0
			4	—	12.6*	12.6*
			5	10 k	240	260
			6	40 k	150	150
			7	120 Ω	2	2
V-16	12BA6	2nd IF STAGE	1	180 k	.2	0
			2	0	0	0
			3	0	0	0
			4	—	12.6*	12.6*
			5	30 k	240	260
			6	15 k	65	65
			7	120 Ω	1	1
V-17	12BA6	3rd IF STAGE	1	150 k	0	0
			2	0	0	0
			3	0	0	0
			4	—	12.6*	12.6*
			5	100 k	240	0
			6	150 k	110	0
			7	150 Ω	2	0
V-18	12AX7	PRODUCT DETECTOR AND 1st AUDIO AMPLIFIER	1	100 k	200	260
			2	40 k	0	-45
			3	5 k	2.8	0
			4	—	12.6*	12.6*
			5	0	0	0
			6	300 k	100	250
			7	10 meg	-.6	-23
V-19	6AQ5	AUDIO AMPLIFIER	1	800 k	0	0
			2	470 Ω	15	0
			3	0	0	0
			4	—	6.3*	6.3*
			5	10 k	300	300
			6	10 k	250	250
			7	800 k	0	0
V-20	0A2	VR TUBE	1	8 k	150	150
			2	0	0	0
			3	INF.	0	0
			4	0	0	0
			5	8 k	150	150
			6	INF.	0	0
			7	0	0	0

*AC OR DC DEPENDING ON SUPPLY

NCX-A POWER SUPPLY

The NCX-A Power Supply is a conservatively rated supply capable of providing all necessary power to operate the National NCX-3 and NCX-5 transceivers. Included with the supply is a 4" x 6" oval speaker which is mounted behind the front panel. The supply is equipped with a power plug and 3' cable so that it may be connected directly to the transceiver, with no other power or speaker connections required.

CAUTION

THIS NCX-A POWER SUPPLY IS WIRED FOR USE WITH THE NCX-5 TRANSCEIVER WITHOUT MODIFICATION. IF THIS SUPPLY IS USED WITH THE NCX-3 TRANSCEIVER, IT WILL BE NECESSARY TO REMOVE RESISTOR R-9 (660 OHMS, 10 WATTS).

Referring to the schematic diagram, 117 or 234 VAC is supplied from the line cord through the power supply protection fuse. A pair of switching leads is connected through Pins 1 and 2 of the cable and plug. A bridge rectifier using diodes D1, D2, D3 and D4, swinging choke L1 and the filter capacitors C1 and C2 provide 700 volts dc to the final amplifier tubes in the transceiver. This high-voltage supply is capable of supplying 700 volts at 50 to approximately 300 ma. at better than 2% regulation from minimum to maximum load. In order to provide maximum efficiency in the NCX-A supply, the low-voltage dc is taken from the

center tap of the high-voltage winding. The low-voltage dc from the center tap is filtered by choke L2 and capacitor C3. It is dropped and further filtered by resistor R5, R6 and R9 and a filter capacitor inside the transceiver. This provides 280 volts at 200 ma. at terminal 9 of plug P1. Resistor R8 is a 30,000 ohm bleeder resistor to prevent shock hazard.

The output of the bias winding of T1 is rectified by diodes D5 and D6. This rectified output is filtered by the combination of resistor R7 and capacitor C4 and provides -80 volts at approximately 10 ma. for bias purposes to terminal 3 of the power plug P1.

NCX-A SUPPLY RATINGS

INPUT:

117 or 234 VAC \pm 10%, 50-60 cycles/second
 150 Watts receive
 365 Watts CW transmit

OUTPUT:

High Voltage 700 VDC at 50 to 300 ma.
 Low Voltage 280 VDC at 200 ma.
 Bias Voltage -80 VDC at 10 ma.

DIMENSIONS

8 1/2" wide x 6 5/16" high x 12" deep

WEIGHT

24 1/2 pounds

ALL READILY AVAILABLE RESISTORS AND CAPACITORS ARE OMITTED FROM THE FOLLOWING PARTS LIST, BUT ARE COMPLETELY IDENTIFIED ON THE SCHEMATIC.

PARTS LIST

NCX-A POWER SUPPLY

DESCRIPTION	PART NUMBER
Plug, Jones, Female	A50828
Strain Relief Bushing	A50892-1
Capacitor, Electrolytic, 40 μ fd	C19458-7
450 VDCW	
Capacitor, Electrolytic, 40 μ fd	C19411-3
150 VDCW Tubular	
Capacitor, Electrolytic, 80 μ fd	C19411-4
450 VDCW Tubular	
Fuse Holder	A50862
Transformer, Power	C51325
Choke, Swinging	B51781
Choke, Filter	B50864

Switch, Transfer	B27662
Rectifier, Silicon 1600 PIV	A50876
Similar to IN2359	
Rectifier, Silicon, 500 PIV	A50874
Similar to IN 534	
Resistor, 7,500 ohms, 5 w \pm 10%	B17436-13
Resistor, 30,000 ohms, 5 w \pm 10%	B17436-14
Resistor, 330 ohms, 10 w \pm 10%	B17436-1
Resistor, 660 ohms, 10 w \pm 10%	B17436-22
Line Cord	B22132-6
Cable, 8 — Conductor	B50877
Front Panel, Complete	D50875-2
Speaker, 6" oval	C50882-3
Cabinet, Complete	D50870-8
Foot, Extension	A50850
Foot, Rubber	A50851

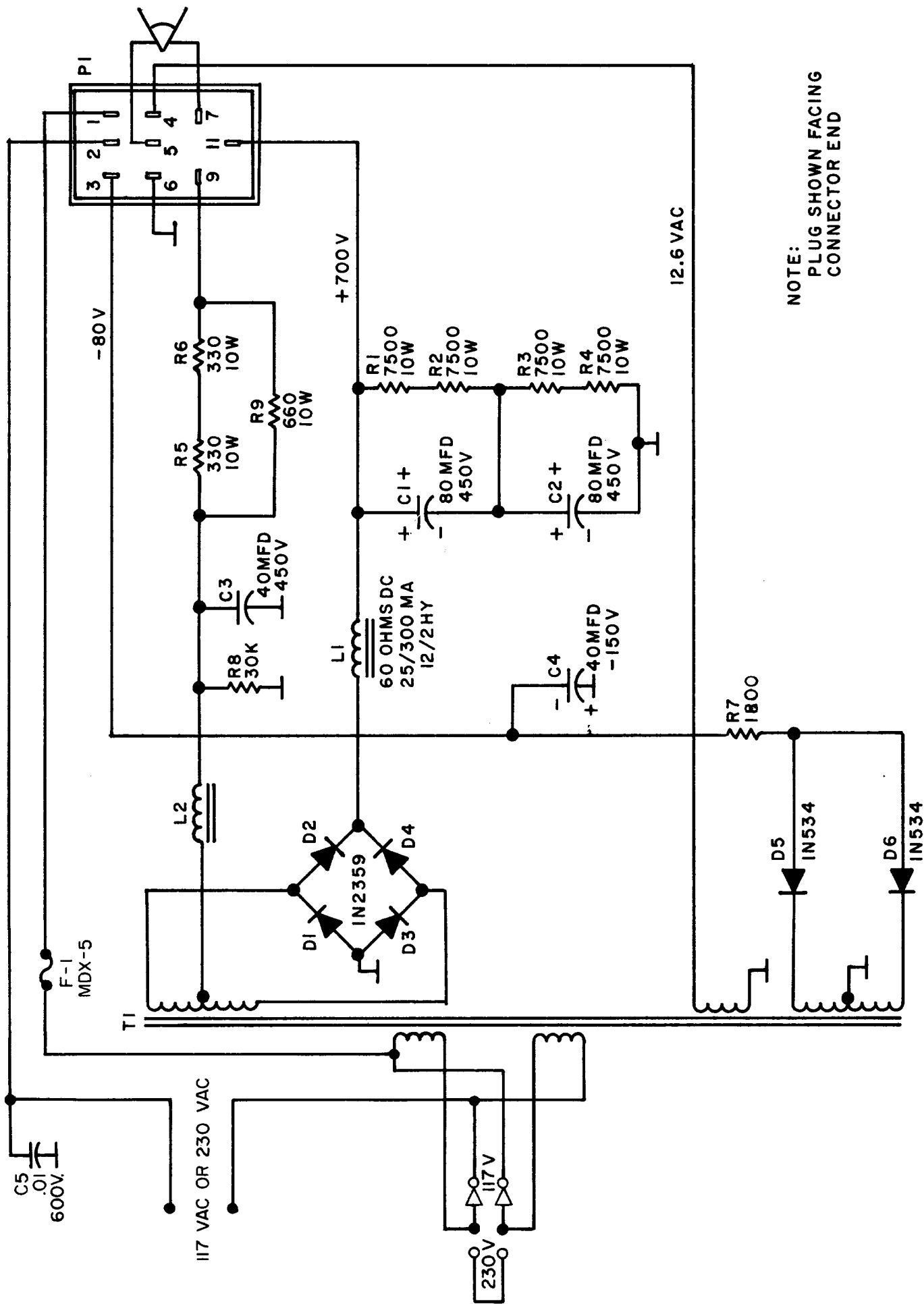

NOTE:
PLUG SHOWN FACING
CONNECTOR END

NCX-A Power Supply Schematic

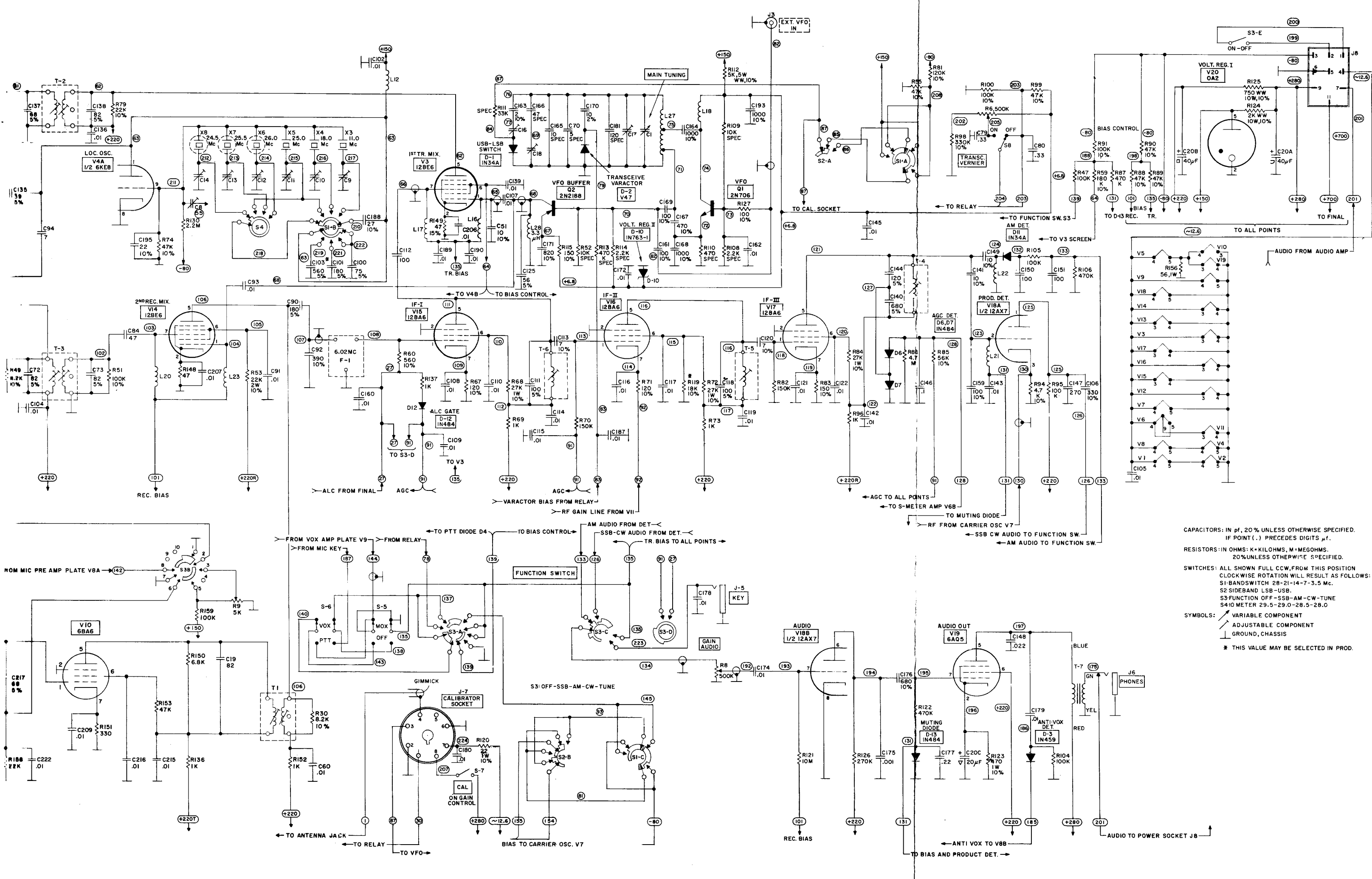

CAPACITORS: IN pF, 20% UNLESS OTHERWISE SPECIFIED.
 IF POINT (.) PRECEDES DIGITS μ F.

RESISTORS: IN OHMS; K=KILOHMS, M=MEGHOHMS.
 20% UNLESS OTHERWISE SPECIFIED.

SWITCHES: ALL SHOWN FULL CCW FROM THIS POSITION
 CLOCKWISE ROTATION WILL RESULT AS FOLLOWS:
 S1-BANDSWITCH 28-21-14-7-3.5 Mc.
 S2-SIDEBAND LSB-USB.
 S3-FUNCTION OFF-SSB-AM-CW-TUNE
 S4-10 METER 29.5-29.0-28.5-28.0

SYMBOLS:
 VARIABLE COMPONENT
 ADJUSTABLE COMPONENT
 GROUND, CHASSIS

* THIS VALUE MAY BE SELECTED IN PROD.

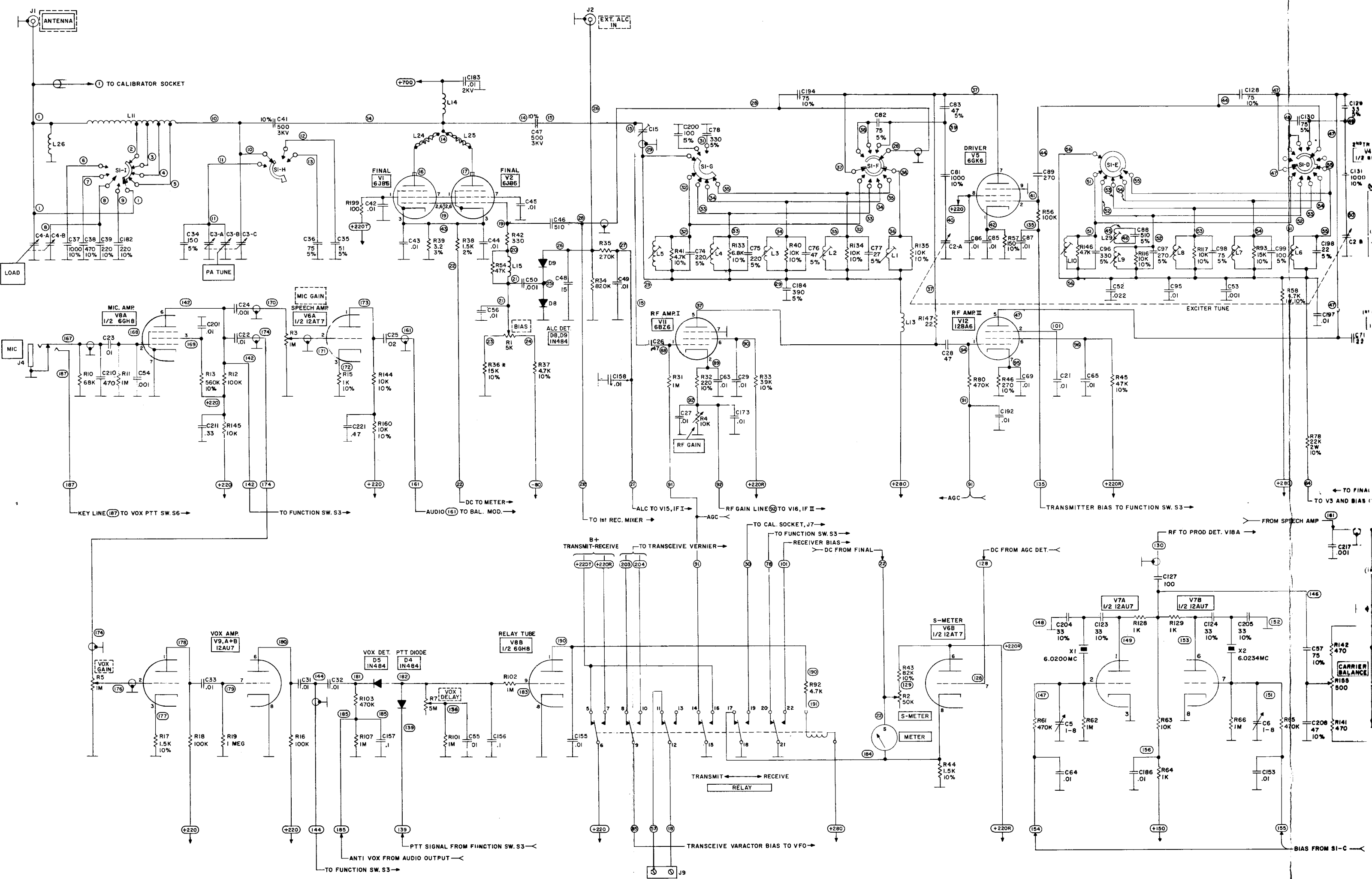

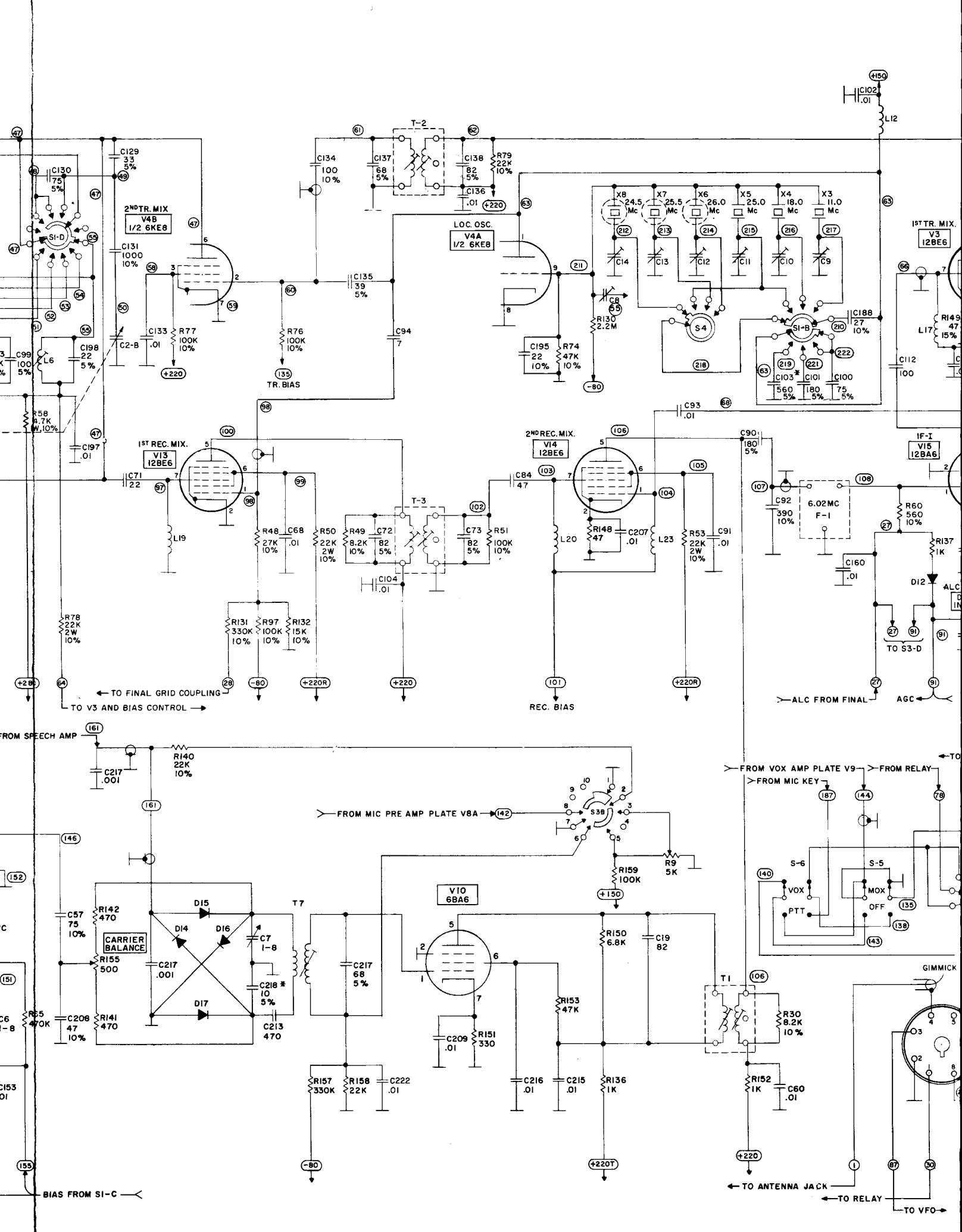

ADDENDA TO THE NCX-5 MK II

MANUAL AND SCHEMATIC

A. The following changes affect the schematic only. These changes have been incorporated in all NCX-5 MK II transceivers, but not recorded on the schematic.

1. Trimmer C8, was shown incorrectly between pin 9 of V4A and ground. It should be shown between pin 7 (plate) of V4A and ground as seen in figure #1.
2. Resistor R74, $47K \pm 10\%$ 1/2 watt between pin 9 of V4A and ground should be shown as a $4.7K \pm 10\%$ 1/2 watt resistor.

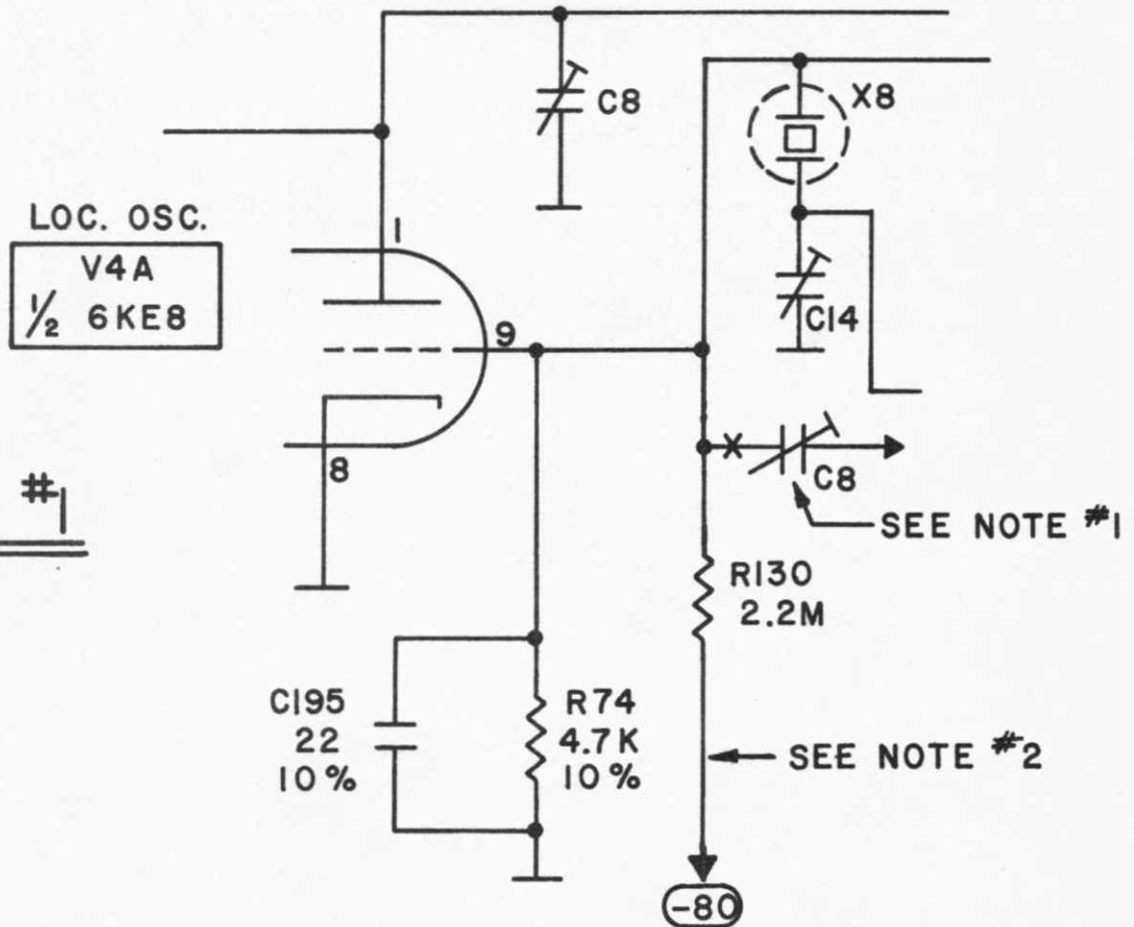
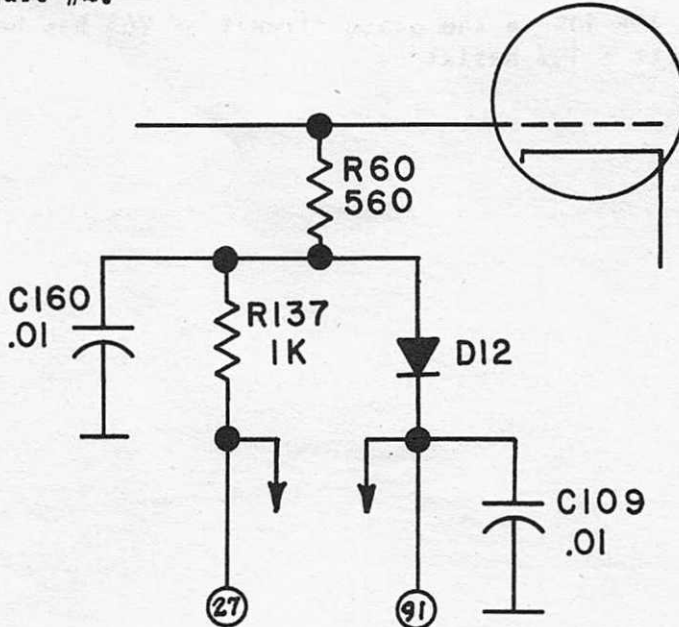

FIGURE #1

3. The VFO and BUFFER transistors have been changed in all NCX-5 MK II transceivers. The new VFO transistor is an RCA 40245 and the BUFFER transistor has been changed to a 2N2672 (Amperex). Changes should be noted in Section 4 and figure #2 of the NCX-5 Instruction Manual.

4. The type numbers of diodes D14, D15, D16, and D17 are not called out on the schematic. They are all type 1N541 diodes. These diodes are in matched pairs and should be ordered as matched pairs. The order number for each pair is 1N542.
5. Capacitor C222, 0.01 uF (located in the grid circuit of tube V10), was printed incorrectly and should be changed to read C212, 0.01 uF.
6. A 0.01 uF ceramic capacitor should be shown between pin 8 of the calibrator socket and chassis ground. A $100 \Omega \pm 10\%$ 1/2 watt resistor should be shown between pin 8 of the calibrator socket and the calibrator switch (S-7).
7. Capacitor C221, 0.47 uF should be shown as a 0.33 uF, 400 V capacitor.
8. Resistor R133, $6.8K \pm 10\%$ 1/2 watt across L-4 should be shown as R133, $4.7K \pm 10\%$ 1/2 watt.
9. Resistor R132, $15K \pm 10\%$ 1/2 watt, should be shown as a $10K \pm 10\%$ 1/2 watt resistor.
10. A $150 \Omega \pm 10\%$, 1/2 watt resistor should be shown between ground and the ground end of the RF gain control (R-4).

11. The value of Capacitor C48 in the ALC DETECTOR circuit is shown incorrectly. Its value should be $0.15 \mu f$.
12. Resistor R137, 1K, in the grid circuit of V15 is shown incorrectly in the schematic. The schematic should be changed to agree with figure #2.



13. Resistor R150, 6.8K in the plate circuit of V10 has been omitted and should be removed from the schematic.
14. The Carrier Balance circuit has been changed. The schematic should be changed to agree with figure #3.

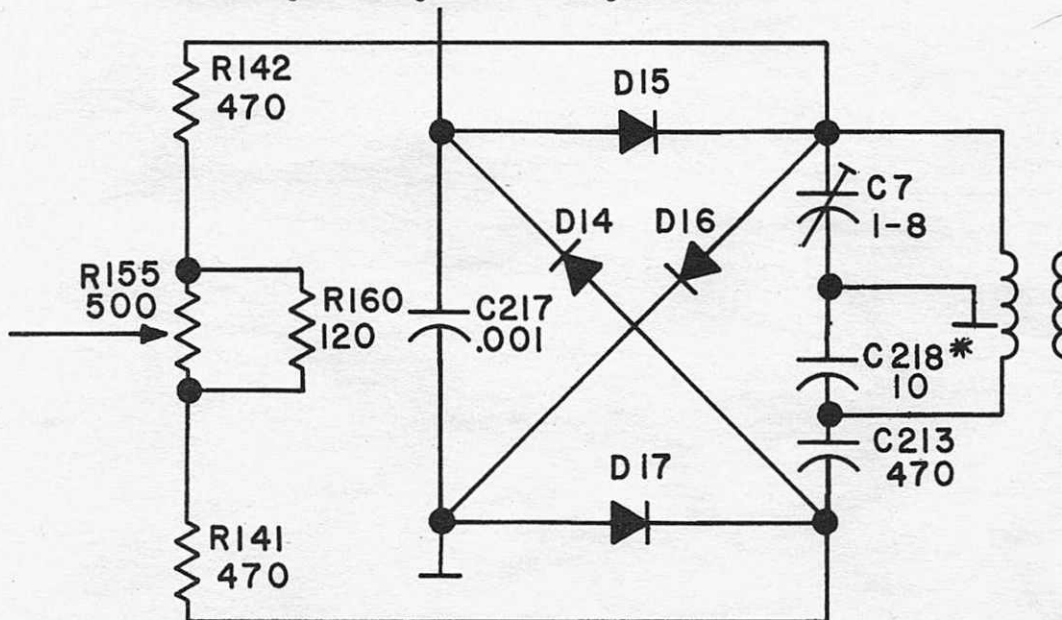

FIGURE 3

15. Resistor R158, 22K in the grid circuit of V10 has been changed to a 220K resistor.
16. Capacitor C159, 100pf \pm 10% in the grid circuit of V18A, has been changed to a 470pf \pm 10% Capacitor.
17. Resistor R160, 10K 10% in the plate circuit of V6A has been changed to a 47K 1/2 watt \pm 10% Resistor.