

# NCX-3 TRANSCEIVER

## *Instruction Manual*

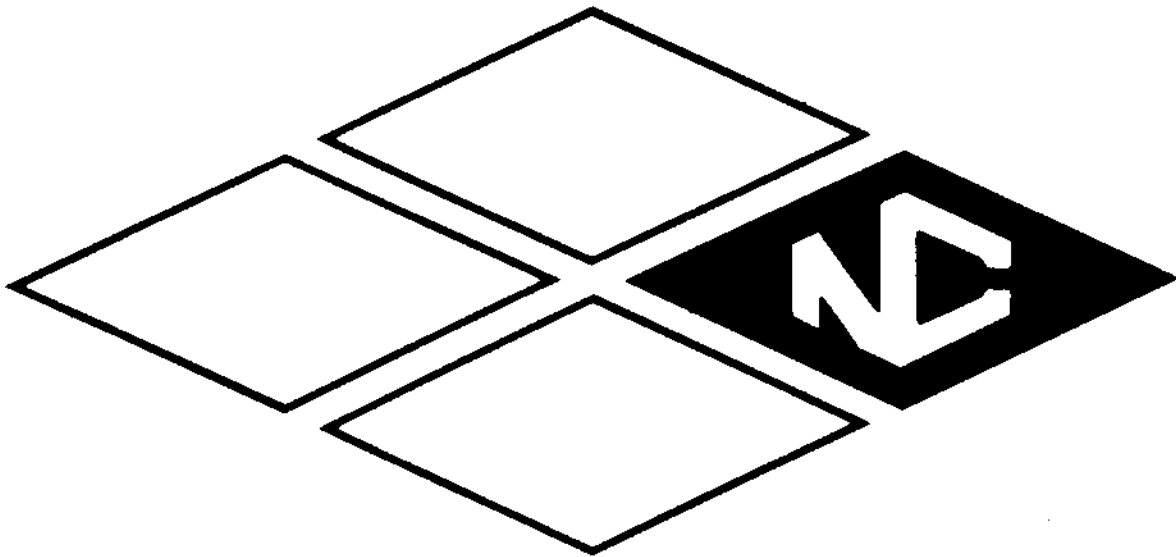

NATIONAL RADIO COMPANY

# INSTALLATION

The NCX-3 transceiver may be used with either the matching NCX-A 115 volt ac or the NCX-D 12 volt dc power supplies. We strongly recommend use of the National Power Supplies designed for the NCX-3 because of their extremely "stiff" voltage regulation and superior filtering. Tests of other commercial supplies advertised for use with the NCX-3 indicate deficiencies in both of these areas which result in unsatisfactory transceiver performance. A mobile mounting bracket is supplied as standard equipment with the NCX-3 transceiver. For mobile operation, this bracket should be mounted to the under surface of the automobile dashboard using two #10, #12 or 1/4 x 20 screws. For maximum mounting stability, these screws should be located as far apart as possible in the mobile mounting bracket. A pair of large threaded knobs is provided for mounting the transceiver directly to the mobile bracket. Use of these knobs will enable rapid installation or removal of the transceiver from the mobile mount. Mobile operation usually results in considerable vibration and shock. For maximum frequency stability of the NCX-3 transceiver, it is important that all mounting screws used to hold the cabinet to the chassis and panel assembly be in place and firmly tightened including the two screws in the upper rear cover of the enclosure which are required for an electrical bond. In mobile use, the rubber feet may be removed from the bottom of the NCX-3, if desired. Unusual mechanical oscillatory vibrations may result with some combinations of automobiles and mounting locations. In such cases braces should be run from the rear of the NCX-3 to the firewall to assure a rigid mount. The NCX-3 mobile bracket has been center punched every 15° to provide for rigid mounting at any desired operating angle. If this rigid mounting feature is desired, it is necessary to drill through the mounting bracket with a 5/32 inch drill. A pair of locking pins is supplied with the NCX-3 which can now be slipped through the drilled holes of the mounting bracket into the mating holes of the transceiver mounting pad. When the threaded knobs are attached, the pins will be captivated holding the transceiver rigidly in position.

## MICROPHONE CONNECTIONS:

The microphone input of the NCX-3 is equipped with a three circuit jack providing a ground on the main shank of the three circuit plug. The audio output of a high impedance microphone (preferably dynamic) should be connected to the ring of the three circuit jack. If the microphone is equipped with a PUSH-TO-TALK button, the PUSH-TO-TALK button should be so wired that the tip of the microphone plug is connected to the grounded shank of the plug when the PUSH-TO-TALK

button is pressed. The microphone PUSH-TO-TALK button is connected to the 10 volt bias. CAUTION: Accidental interchange of the wiring on the microphone plug will result in application of 10 volts to the microphone cartridge which may damage the microphone. The microphone input jack of the NCX-3 is equipped with a grounding contact so that no modulation of the transceiver is possible when the microphone plug is removed. Microphone connections are illustrated in figure #1. We strongly recommend the use of a good quality wide range dynamic microphone, since all necessary restriction of audio bandwidth is accomplished in the NCX-3 crystal lattice filter. The PTT circuitry of the microphone should be modified to permit vox operation without depressing the PTT button.

## MOBILE SPEAKER INSTALLATION:

When the NCX-3 is installed in an automobile for use with the NCX-D supply, it will usually be most convenient to use the speaker of the regular automobile broadcast radio. Two leads should be brought out of the 12 terminal Jones plug at the rear of the NCX-3 (pins 5 and 7) and connected to the speaker through a DPDT switch mounted under the dash to allow choice of speaker operation with either the NCX-3 or the standard broadcast radio. Do *not* use the automobile chassis as the speaker ground return, since unwanted ground loops may cause excessive whine in the speaker.

## AUXILIARY RELAY CONTROL TERMINALS:

A set of SPDT relay terminals rated at 1 ampere current capacity is provided at the rear of the NCX-3 to allow control of accessory equipment during the transmit-receive cycle. Terminals 1 and 2 are open during receive, closed during transmit.

Figure 1 shows one application of the NCX-3 auxiliary relay terminals: the control of an external DPDT (or pair of SPDT) coaxial relay (s) to allow the NCX-3 to be used with a separate high power linear amplifier. Note that as shown in the receive position, the NCX-3 is connected directly to the antenna through the two sets of external relay contacts. When voltage is supplied to the external relay(s) through the NCX-3 control terminals during transmit, the NCX-3 output is fed to the amplifier input and the amplifier output is fed to the antenna. The insertion of an SPDT switch in the external relay voltage line allows instant selection of either straight-through operation with the NCX-3 or high power operation with the linear. This switch must be thrown to the "straight-through" position when the NCX-3 is turned off to prevent operation of the external relay.

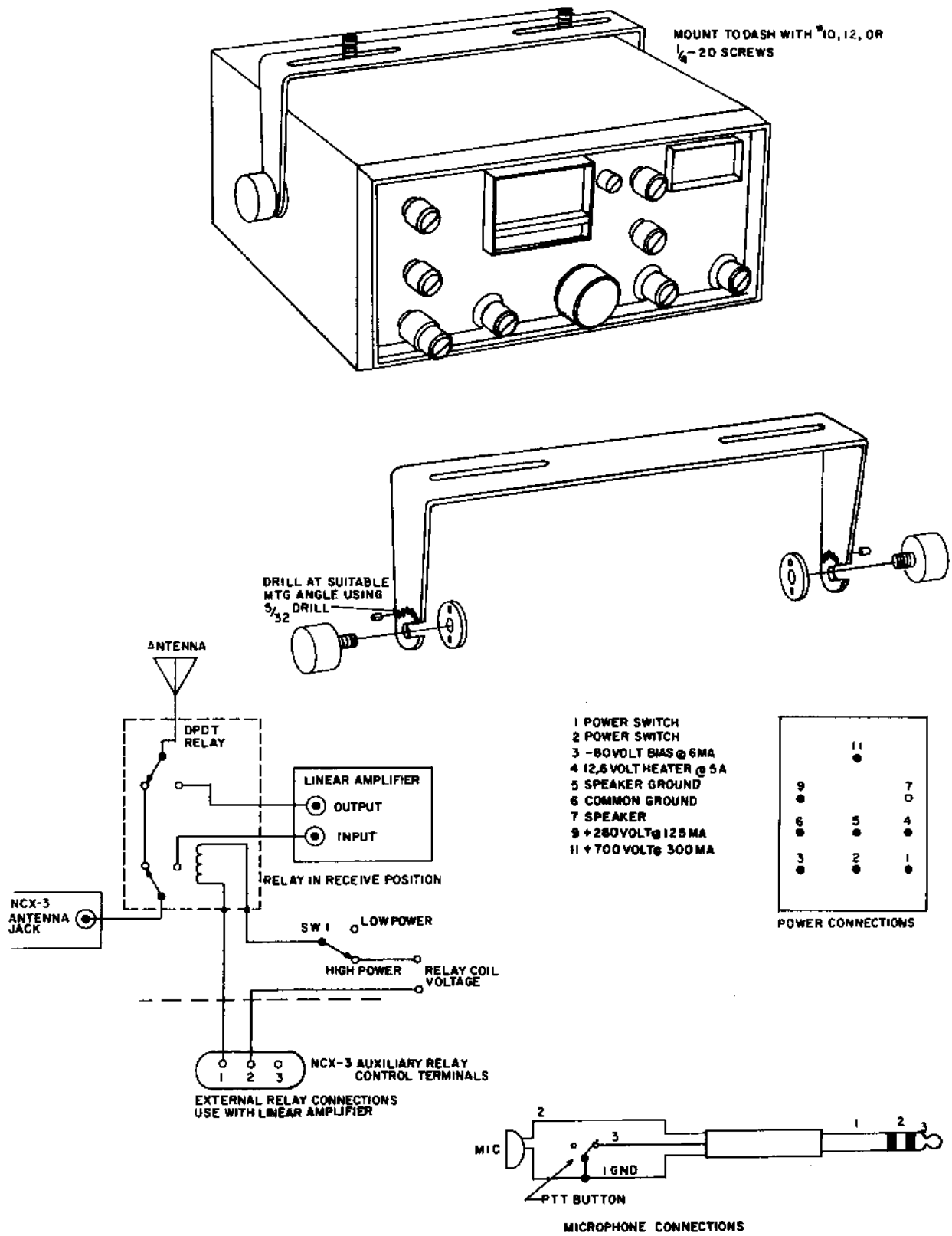

Figure 1. NCX-3 Installation

## OPERATION

The NCX-3 transceiver combines a single conversion superheterodyne receiver and a filter type single side-band transmitter designed for use on the 80, 40 and 20 meter amateur bands. A suitable power supply with excellent regulation and filtering such as the NCX-A or NCX-D power supplies, must be provided for operation of the NCX-3 transceiver. Figure 1 illustrates the necessary power connections and power requirements. When the NCX-3 is used with the NCX-A power supply, the cable of the power supply is wired for direct connection to the NCX-3 and no additional power connections must be made. A speaker is incorporated as an integral part of the NCX-A power supply. When the NCX-D power supply is used, connections to the power supply from the primary 12.6 volt source and between the power supply and transceiver should be made in accordance with the wiring instructions included with the NCX-D power supply. During mobile operation, make certain that the VR tube remains lit at all times and does not extinguish during voice peaks or under full TUNE input. Such VR tube extinction will cause severe frequency shift with modulation. Extinction of the VR tube usually results from improper loading or low +280 volt output from the DC supply. It is important to use a DC supply which will provide rated power to the transceiver and to provide adequate primary voltage to the DC supply.

### CAUTION

BEFORE ATTEMPTING TO OPERATE THE NCX-3 TRANSCEIVER, THE FOLLOWING PRELIMINARY CONNECTIONS SHOULD BE MADE: A SUITABLE ANTENNA, PRESENTING 40 TO 60 OHMS RESISTIVE LOAD IMPEDANCE SHOULD BE CONNECTED TO THE ANTENNA TERMINALS, A PROPER POWER CABLE SHOULD BE CONNECTED FROM THE POWER SUPPLY TO THE NCX-3 TRANSCEIVER, AND A MICROPHONE OR KEY SHOULD BE CONNECTED TO THE APPROPRIATE INPUT JACKS. THE FUNCTION SWITCH SHOULD REMAIN IN THE OFF POSITION WHILE THESE CONNECTIONS ARE BEING MADE.

### SSB OPERATION

1. Set front panel controls as follows:  
 MIC GAIN fully ccw  
 CARRIER BALANCE at 12 o'clock  
 RF GAIN fully cw  
 AUDIO GAIN at 9 o'clock  
 BAND and MAIN TUNING on proper band and frequency  
 PA TUNE, PA LOAD and EXCITER TUNE fully ccw

2. Set rear panel controls as follows:  
 VOX SENSITIVITY and VOX DELAY fully ccw  
 BIAS control at 12 o'clock  
 VOX-PTT switch on PTT if microphone has PTT switch, otherwise on VOX

### RECEIVER TUNE-UP (SSB)

1. Turn FUNCTION switch to SSB. After several seconds' warm-up, the NCX-3 transmit-receive relay should close with an audible click. The NCX-3 is now in a receive condition on the selected band and frequency.
2. Adjust PA TUNE and EXCITER TUNE for maximum S-meter reading or background noise. This adjustment automatically sets up approximate transmit tuning since these controls are common for both transmitter and receiver.
3. Adjust AUDIO GAIN for comfortable listening level.

### TRANSMITTER TUNE-UP (SSB)

1. Turn FUNCTION switch to TUNE and adjust EXCITER TUNE for maximum meter reading.
2. Adjust PA TUNE for minimum meter reading (dip) indicating proper tuning of the final Pi network.
3. Return FUNCTION switch to SSB. If the microphone is equipped with a push-to-talk button and the rear VOX-PTT switch is set for PTT operation, depress the microphone button and rotate the CARRIER BALANCE control for minimum meter reading.

### NOTE

IF THIS IS THE FIRST TIME THE NCX-3 TRANSCEIVER HAS BEEN PLACED IN OPERATION, THE REAR PANEL BIAS CONTROL SHOULD BE ADJUSTED. HOLD THE PUSH-TO-TALK BUTTON DEPRESSED AND ROTATE THE CARRIER BALANCE CONTROL FOR MINIMUM METER READING ACCORDING TO THE INSTRUCTIONS OF STEP 3. NOTE THE METER READING AT THIS SETTING. IT SHOULD BE BETWEEN 50 AND 60 MA. IF IT IS NOT, ADJUST THE REAR PANEL BIAS CONTROL UNTIL THIS CONDITION IS ACHIEVED.

4. If microphone is not equipped with a push-to-talk button, set the rear panel VOX-PTT switch in the VOX position. Leave the MIC GAIN control fully ccw. Rotate the rear panel VOX SENSITIVITY con-

trol, until the transmit-receive relay trips with speech information to the microphone. Hold the relay in a transmit condition with a steady tone or sound into the microphone. While holding the relay in this manner, the front panel CARRIER BALANCE control and the BIAS adjustment can be made as described in step 3.

5. Return the FUNCTION switch to TUNE and adjust EXCITER TUNE and PA TUNE as described in step 1. Slowly rotate the PA LOAD control cw and "dip" meter reading with PA TUNE control until meter reads 300 ma. Return FUNCTION switch to SSB. The transmitter is now properly tuned and loaded.

### NOTE

DO NOT PROLONG TUNE-UP PROCEDURES MORE THAN 30 SECONDS AT A TIME IN ORDER TO PREVENT UNNECESSARY OVERHEATING OF COMPONENTS DURING OUT-OF-RESONANCE CONDITIONS. AFTER EXPERIENCE IS GAINED, TUNE-UP MAY BE ACCOMPLISHED IN A MATTER OF A FEW SECONDS.

### MICROPHONE GAIN ADJUSTMENT

1. For push-to-talk operation, throw rear panel VOX-PTT switch to PTT. Depress microphone button and advance MIC GAIN control while talking until average meter reading is between 100 and 150 ma., with only occasional higher peaks. It is important to remember that the NCX-3 meter reads 500 ma. full scale, and is well damped. Peak current is actually in the 300 ma. area (depending on individual voice characteristics) and the NCX-3 is running a full 200 watts peak input. This adjustment, as in any SSB transceiver, is best performed with the aid of an oscilloscope, but the above techniques will serve until a more optimum adjustment can be made with the help of an oscilloscope or an on-the-air check by another amateur with good receiving equipment.

2. For VOX operation, turn rear panel VOX-PTT switch to VOX. Turn receiver MIC GAIN control completely ccw, and rotate rear panel VOX SENSITIVITY control until the relay just trips easily while speaking into the microphone at normal level and distance.

SUFFICIENT VOX GAIN IS AVAILABLE IN THE NCX-3 TO ALLOW FULL ANTI-VOX INSERTION AT ALL TIMES and so no ANTI-VOX Control Potentiometer is necessary. Adjust VOX DELAY until VOX relay holds for the desired time after speaking.

THE ABOVE ADJUSTMENTS ALL INTERLOCK TO A SMALL DEGREE, AND IT MAY BE NECESSARY TO REPEAT ALL ADJUSTMENTS ONCE OR TWICE TO OPTIMIZE RESULTS.

3. Adjust MIC GAIN control as in step 1.

VOX OPERATION, WHILE MOBILE, IS QUITE EASY AND PRACTICAL, BUT VOX SENSITIVITY AND MIC GAIN SHOULD BE ADJUSTED FOR CLOSE-TALKING TO PREVENT CAR AND WIND NOISES FROM TRIPPING THE RELAY.

4. Your NCX-3 is now tuned and ready to operate. EXCITER TUNE and PA TUNE should be re-adjusted when substantial frequency changes are made.

### CW OPERATION

1. It is assumed that the NCX-3 has been set up for SSB operation and it is now desired to operate CW.

2. Insert key plug in rear panel jack.

3. Set MAIN TUNING to desired CW frequency.

4. Turn FUNCTION switch to TUNE and adjust transmitter as for SSB operation.

5. Turn FUNCTION switch to CW, depress key and adjust CARRIER BALANCE control until meter reads 300 ma.

6. The NCX-3 is now tuned for CW operation, and is ready for full break-in operation. When the key is depressed to start sending, the VOX relay in the NCX-3 automatically switches from receive to transmit. The VOX relay will hold in until the operator stops sending, and then will automatically switch to receive. By adjusting the rear panel VOX DELAY control, the operator may set the "hold-in" relay time to his liking. An external keying monitor may be helpful in monitoring sending.

### AM OPERATION

1. It is assumed the NCX-3 has been set up for SSB operation and it is now desired to operate AM.

2. Either VOX or PTT operation should be selected.

3. Turn FUNCTION switch to TUNE and adjust transmitter to 300 ma. under tune conditions.

4. Turn FUNCTION switch to AM, turn MIC GAIN fully ccw, and trip transmit relay as described in step 1 or 2 under Microphone Gain Adjustment.

5. Adjust CARRIER BALANCE until meter reads 150 ma.

6. Advance MIC GAIN until meter just flickers on voice peaks.

7. The NCX-3 is now adjusted for AM operation, and the AM detector is automatically in use. Because of the high skirt selectivity of the NCX-3 filter, AM signals will probably sound more natural when tuned slightly to one side of the "peak."

## THEORY OF OPERATION

The NCX-3 transceiver, designed to cover the 80, 40 and 20 meter amateur bands, combines a single conversion superheterodyne receiver and single side-band transmitter, both employing a common crystal lattice filter. The final Pi network and driver tuning circuits of the transmitter serve as common RF circuits for the receiver. The carrier oscillator and VFO are common to the receiver and transmitter circuits while

the receiver first IF stage is used as a low level amplifier in the transmitter-exciter function. The use of common filter and RF input components, in particular, results in an extremely sensitive and image-free selective receiver as well as a high quality, low distortion SSB transmitter.

The operation of the NCX-3 is best understood by reference to the block diagram, figure 2.

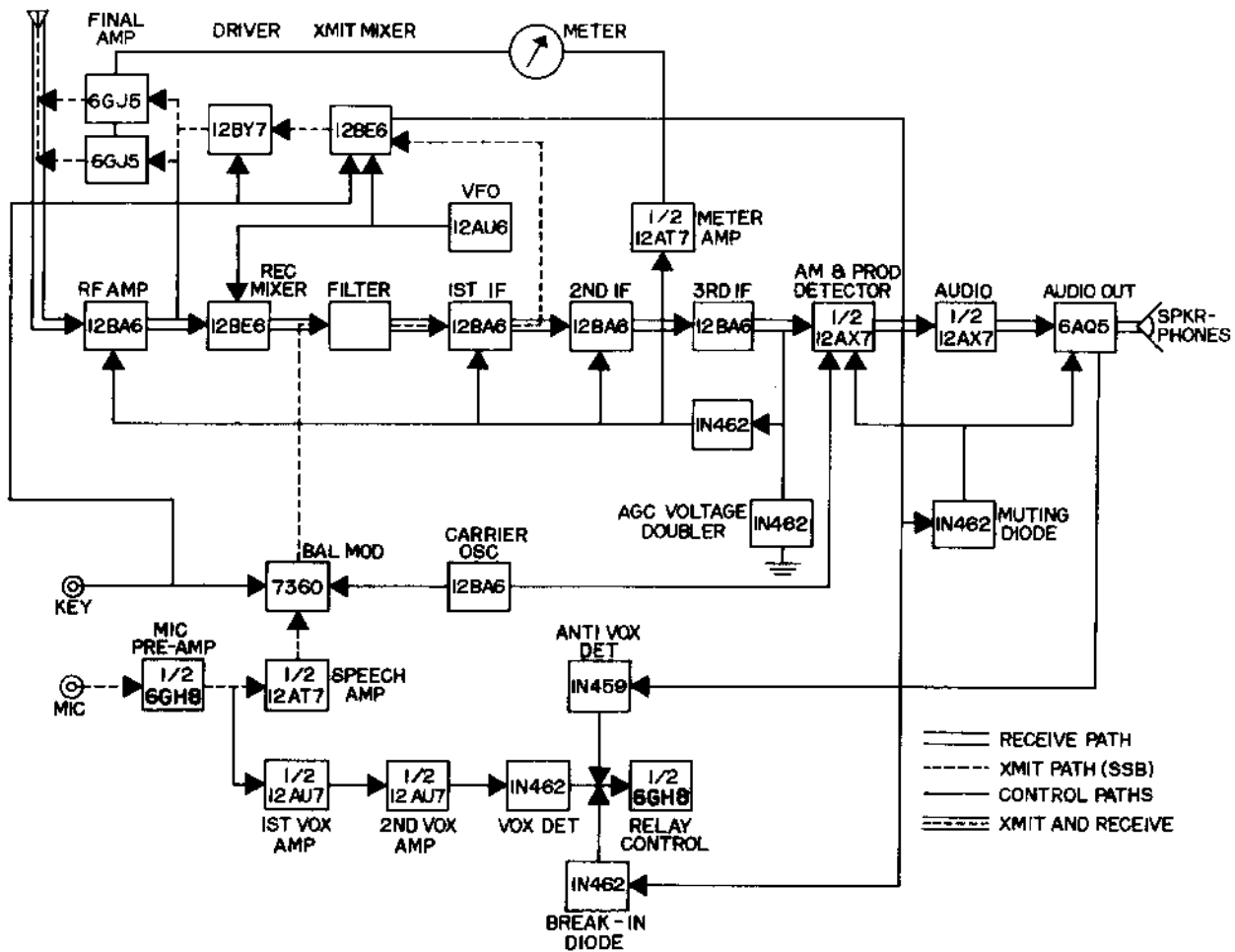

**Figure 2. NCX-3 Block Diagram**

## THE TRANSMITTER

The transmit signal path of the NCX-3 is indicated on the block diagram by a dashed line. The microphone input circuit is designed for high impedance dynamic or crystal microphones and provides for connection to a push-to-talk microphone circuit. The microphone input is connected directly to the grid of the pentode section of a 6AN8 tube which operates as a microphone pre-amplifier. The output at the plate of the microphone pre-amplifier is coupled to the microphone gain control which feeds the grid of a triode section of the 12AT7 tube which is used as a speech amplifier. The plate circuit of this speech amplifier is coupled to one of the deflection electrodes of the 7360 balanced modulator.

A 12BA6 tube is used as a crystal controlled Pierce oscillator operating at 5.2003 mc. for carrier generation. The oscillator circuit uses the screen and cathode of the 12BA6 tube. The oscillator section is electron coupled to the suppressor and plate circuits which feed the balanced modulator load. The carrier signal is obtained across a resistive plate load and fed through a voltage divider to the grid of the 7360 balanced modulator. A balancing network is connected to the front panel carrier balance control and the deflection electrodes of the 7360 balanced modulator tube. In addition, the plate of the balanced modulator provides phase balancing through C107 for maximum carrier suppression. The balanced primary winding is coupled to a single-ended secondary which serves as both the input source and load for a four-pole crystal lattice filter.

The output of the crystal lattice filter is fed to the grid of a 12BA6 first IF stage with a single tuned plate circuit tuned to approximately 5.2 mc. The output of this plate circuit is coupled to the grid of the 12BE6 transmit mixer.

The VFO uses a 12AU6 tube operating as a grounded plate Colpitts oscillator. The tank circuits of this oscillator use extremely stable capacitors to provide for minimum warm-up drift and maximum frequency stability. As in the carrier oscillator, the actual oscillator circuit operates between the screen and cathode of the 12AU6 tube so that electron coupling may be used for isolation of the loads. Output from the VFO is obtained across a resistive plate load and is coupled to the oscillator grid of the 12BE6 transmit mixer.

The plate circuit of the transmit mixer contains a single tuned coil which feeds the grid of the 12BY7 transmit driver. The plate circuit of the transmit driver also contains a single tuned tank circuit which feeds the grid of the final amplifier. The coils in the plate circuits of the transmit mixer and transmit driver are band switched to provide for coverage of the 80, 40 and 20 meter amateur bands. The tuning gang is tracked so that exciter tuning can be accomplished with only one control. The gains of the transmit mixer and driver are such that a driving signal in excess of

100 volts can be obtained at the grid of the final amplifier, thus assuring linear operation of the exciter to well above the level necessary for proper drive to the final.

The final amplifier employs a pair of 6GJ5 tubes operating in parallel. A bias adjustment is provided in the grid circuit for adjustment of idling current. The plates of the 6GJ5 final amplifier are coupled to a high-efficiency Pi network. The Pi network incorporates band switching for selection of proper inductance and load capacitance to enable tuning of a 40 to 60 ohm resistive load over the entire 80, 40 and 20 meter amateur bands. The Pi network is designed for continuous operation at a power level of 200 watts input. Neutralization is provided by means of a small adjustable capacitor coupled from the plate of the 6GJ5 final amplifier to the partially bypassed return of the final grid circuit coils (driver plate coils). When the NCX-3 final amplifier is properly neutralized, maximum output on a matched antenna will occur at the point of plate current dip as indicated on the cathode current meter.

## THE RECEIVER

The NCX-3 receiver circuits are indicated by the double solid lines in the block diagram, figure 2. The receiver RF circuits are common to the transmitter circuits. The high impedance point of the final Pi network, at the plates of the 6GJ5 tubes, is capacitively coupled to the grid of a 12BA6 RF stage while the plate coils of the 12BY7 transmit driver stage are connected directly in parallel with the plate of the 12BA6 RF amplifier thus providing for receiver RF selectivity and common receiver-transmitter tuning of the antenna and RF circuits. The output from the plate of the RF amplifier is coupled to the signal grid of the 12BE6 receive mixer. Output from the VFO is coupled to the oscillator grid of the 12BE6 receive mixer. The plate circuit of the receive mixer is connected directly across the secondary of the balanced modulator transformer which serves as the input coil to the crystal lattice filter.

The output of the crystal lattice filter is identical to the circuit used for transmission and couples to the grid of a 12BA6 first IF amplifier. The plate circuit of this amplifier employs a single tuned circuit operating at approximately 5.2 mc. which feeds the grid of the second IF amplifier, as well as the transmit mixer previously mentioned. The plate of the second IF amplifier again employs a single tuned circuit to feed the grid of the third IF amplifier, and the plate circuit of the third IF amplifier employs a single tuned circuit which feeds the detector and AGC circuits through separate voltage dividers. The product detector employs one triode of the 12AX7 tube with the signal from one IF voltage divider fed to the grid. A BFO signal is coupled from the crystal controlled carrier oscillator to the cathode of the product detector,

and the resulting audio signal is obtained across a resistive load in the plate circuit. In AM operation, the cathode of the product detector is grounded, thus providing a highly efficient grid leak AM detector.

The output from the plate circuit of the product detector is coupled to the audio gain control, thence to the grid of the remaining triode section of the 12AX7 tube functioning as a grid-leak biased, first audio amplifier. The plate circuit is coupled to the grid of the 6AQ5 audio output stage. The plate circuit of the audio output stage feeds the output transformer having a secondary designed to match a 3.2 ohm speaker load. This output signal is also available at the phone jack. The low-impedance nature of the phone jack feed permits use of either high- or low-impedance phones with satisfactory operation.

A second feed is obtained from the plate circuit of the last IF amplifier and is fed to a voltage-doubling AGC rectifier. The low-impedance driving source provides a rapid charge of the AGC bus. When the signal disappears, the negative AGC voltage on the AGC bus cannot discharge through the diodes and must discharge through R55 which provides a long release time, thus making the AGC circuit a very effective, fast-attack, slow-release circuit. This AGC information is fed to the grid of the remaining half of the 12AT7 tube, functioning as an S-meter amplifier, and is also coupled to the grids of the RF stage, and the first and second IF stages for AGC control.

## THE SWITCHING CIRCUITS

A front panel function switch provides for OFF-SSB-AM-CW-TUNE functions. A rear panel mode switch provides for VOX or PTT operation. When the front panel function switch is in the OFF position, the primary power circuit is open. When the NCX-3 is used with the NCXA power supply, this switch controls the 117 volt AC power to the power supply. When the NCXD power supply is used, this switch controls power to a primary power switching relay in the power supply unit.

Transmit-receive circuit transfer of the NCX-3 is provided by the use of switched bias voltages to assure maximum trouble-free operation. In addition, only one relay is used. While receiving, the relay is closed; while transmitting, the relay is open. Specific relay contacts function identically for all modes of operation and will be discussed first:

1. External Relay Terminals:
  - a. Terminals 1 and 2 open on receive, closed on transmit.
  - b. Terminals 2 and 3 closed on receive, open on transmit.
2. Receiver Bias:
  - a. Grounded on receive.
  - b. Open with -40 volts with the bus on transmit.

3. AGC:
  - a. Open with AGC information present on receive.
  - b. Grounded on transmit.
4. Transmit B:
  - a. Grounded on receive.
  - b. Closed with 220 volts on transmit.
5. Receive B:
  - a. Closed with 220 volts present on receive.
  - b. Open on transmit.
6. S-Meter Circuit:
  - a. Open for S-meter operation on receive.
  - b. Grounded on transmit.

There is one remaining switching function important to the various modes of operation of the NCX-3. In order to consider this switching operation, we must first discuss the VOX circuits. A signal coupled from the plate of the 6AN8 pentode speech amplifier to the VOX sensitivity control is, in turn, coupled to the grid of the first VOX amplifier. The signal at the plate of the first VOX amplifier couples to the grid of the second VOX amplifier. The VOX signal at the second VOX amplifier plates couples to the VOX detector. A signal simultaneously derived from the plate of the 6AQ5 audio output tube is fed to the ANTI-VOX sensitivity control which in turn feeds the ANTI-VOX detector. A DC voltage, proportional to the audio information passing through the receiver channel, is developed by the ANTI-VOX detector and is used to back-bias the VOX detector. With proper control setting, the amount of information obtained from the loud speaker through the microphone and VOX channel is always less than obtained directly from the audio output stage through the ANTI-VOX detector. Thus, speaker information coupling into the NCX-3 microphone will not trip the VOX circuit. Any additional information, such as the voice of the operator, will cause the VOX information to exceed the ANTI-VOX information and the VOX detector will begin to conduct. The resulting negative voltage at the VOX detector output is developed across an RC network in which the resistor is varied by means of the DELAY control. The low-impedance driving source of the VOX circuit allows rapid charging of the circuit. The discharge time can be varied from a fraction of a second to several seconds. This negative voltage is applied to the grid of the relay control tube and causes the relay to open when VOX information is obtained through the microphone channel thus placing the NCX-3 in a transmit condition.

If the front panel function switch is placed in the SSB or AM positions and the rear panel function switch is placed in the VOX position, speech information will trip the relay. Transmit bias is grounded through an additional relay terminal not mentioned above, thus making the transmitter operative by removing the bias and connecting the necessary B+ information. Simultaneously, the receiver is silenced by



bias which appears on various receiving stages. When VOX information disappears from the microphone channel, depending upon the setting of the delay control, the bias on the grid of the relay tube will disappear and the relay will close, returning the NCX-3 to a receiving condition.

For push-to-talk operation (PTT), the rear mode switch is placed in the PTT position. This accomplishes two different connections. First, the output of the VOX amplifier is short-circuited, thus preventing tripping of the relay by any voice information from the microphone channel. Secondly, the transmit bias bus is disconnected from the relay and can be shorted to ground through the push-to-talk button. This alone will not change the NCX-3 from a receive to transmit condition. The screen of the transmit mixer which is fed through a 22,000 ohm resistor is at approximately 220 volts during receiving conditions. When the transmit bias bus is shorted by the push-to-talk button, the transmit mixer starts to conduct, dropping screen voltage to approximately 80 volts. A voltage divider is arranged from this screen to the bias supply in such a manner that the voltage is approximately 5 volts positive on receive and 40 volts negative on transmit, due to the current drawn by the screen of the transmit mixer. This negative voltage is fed to the grid of the relay tube through the keying diode causing the relay to open, placing the NCX-3 in a transmit condition, thus completing the switching of the NCX-3 in the PTT mode.

It should be noted here that bias derived from the screen of the transmit mixer is also supplied to the audio output and product detector stages by use of the muting diode, thus silencing the receiver before the relay has a chance to function, thereby providing for completely silent receive-transmit switching. On the reverse transition from transmit to receive, a time constant is included on the receive bias bus which is fed to the first audio amplifier thus assuring that bias will remain on the first audio amplifier until after the relay has closed, again providing a silent transmit-receive transition.

With the front panel function switch placed in the AM position, the control operation is identical to that on the SSB position. The VOX functions of the mode switch may be used in the same manner as used for single sideband operations. For AM operation, the transmit bias bus is connected through the function switch and relay to the grid of the carrier oscillator, causing the oscillator to stop functioning each time the NCX-3 is in a receive condition, thus providing proper

AM reception without BFO. At the same time, the cathode of the product detector is grounded to convert it to a grid-leak AM detector. When transmit bias is removed, the bias on the carrier oscillator disappears and normal carrier generation is obtained.

With the front panel function switch in the CW position, the plate circuit of the speech amplifier is grounded. This eliminates the possibility of the microphone producing unwanted modulation during CW operation and also prevents tripping of the VOX circuit by information entering a live microphone channel. The key is connected to the transmit bias bus on the CW position. However, to prevent accidental tripping of the transceiver, it is not connected on the AM and SSB positions. The function of the keying circuit is identical to that of the push-to-talk circuit with the exception that after the relay has tripped, as discussed on the push-to-talk function above, the delay time constant of the VOX circuit will hold the relay in a transmit condition. The key is directly connected to the transmit bias bus and each time it is opened, the transmitter will cease functioning due to the presence of bias on the transmit mixer, driver and balanced modulator. The relay will trip at the instant the key is touched. The relay will then remain open resulting in grid block keying. When keying stops, the delay time constant will allow the relay to close returning the NCX-3 to a receive condition.

Finally, with the function switch in the TUNE position the transmit bias is grounded, again placing the NCX-3 in transmit and tripping the relay. In this case, the function switch also grounds one of the deflection electrodes of the 7360 balanced modulator, providing complete carrier unbalance for purposes of tuning the transmitter.

Metering is accomplished by using an accurate D'Arsonval meter designed to read voltage across a very small value cathode resistor in the cathode return of the two 6GJ5 final amplifiers. During transmit, the S-meter side of the metering circuit is grounded, providing a direct return of the cathode current metering circuit. During receive, there is no current flowing in the 6GJ5 amplifier tubes due to the removal of screen voltage from the 6GJ5 final amplifier by the relay terminals. The S-meter amplifier cathode is ungrounded and the S-meter circuit return path is completed through the cathode resistance of the final amplifier. Thus a single meter functions as a cathode current meter when the NCX-3 is placed in a transmit condition, and as an S-meter when in a receive condition.

## DETAILED USE OF THE INDIVIDUAL CONTROLS

The operating instructions in the first pages of this manual enable rapid set-up of the NCX-3 for SSB, AM or CW transmission. A more thorough knowledge of the operation of the individual controls will allow the operator greater flexibility and will encourage better operating practices. Operation of the AUDIO GAIN control, the BAND switch and the MAIN TUNING control are conventional and straightforward and will not be discussed in the following section.

### THE FUNCTION SWITCH

It is important to note the various interlocking features of the FUNCTION switch. In the SSB or AM positions of the FUNCTION switch, either VOX or PTT operation may be used. The rear panel VOX-PTT switch selects either of these two modes of operation. The rear panel key jack is disconnected from the internal circuit of the NCX-3 in these two positions, thus allowing a key to be plugged into the NCX-3 under all modes of operation. Accidental closing of the key will not trip the unit to transmit if the FUNCTION switch is in either the SSB or AM position. In the AM position, the FUNCTION switch grounds the cathode of the product detector to convert it to an efficient triode detector and applies transmit bias to the carrier oscillator during receiving periods thus silencing the beat frequency oscillator of the receiver.

If the front panel FUNCTION switch is placed in the CW position, the rear panel key jack is connected for automatic break-in operation. At the same time, the plate of the microphone pre-amplifier is grounded to prevent accidental modulation of the transmitted signal by a microphone connected to the NCX-3. During CW operation, the rear panel MODE switch can be in either the VOX or PTT positions without any effect on the operation of the transceiver. The slight audio "beep" which may be heard from the loud-speaker at the beginning of each keying cycle is the result of the extremely fast attack time of the break-in CW circuit which eliminates "clipping" of the first dot.

Finally, in the TUNE position of the FUNCTION switch, the keying circuit is internally grounded, placing the NCX-3 in a transmit condition. At the same time one of the deflection electrodes of the 7360 balanced modulator tube is grounded, providing for more than normal drive to the final amplifier for tune up. It is important to note that if the FUNCTION switch is placed in the TUNE position and an antenna is connected to the NCX-3, full power transmission of a CW note will occur and can cause unwanted interference on the frequency and band in use. Tune-up procedure should therefore be limited to as short a time as possible.

### THE PA TUNE AND PA LOAD CONTROLS

Adjustment of the PA TUNE and PA LOAD controls is inter-dependent. For normal use, the NCX-3 is placed in a TUNE position. The EXCITER TUNE control is set for maximum meter indication. The PA TUNE control is then set for minimum indication, indicating resonance of the Pi network. For a normal 40 to 60 ohm resistive antenna, the PA LOAD control should then be rotated from a maximum ccw position to increase the meter reading. As this is done, there will be some inter-action with the PA TUNE control and it will be necessary to slightly retune for minimum meter indication. As the PA LOAD is advanced, the minimum meter reading will increase. Proper loading for 200 watts peak input occurs at 300 ma. (marked in red on the meter scale). This loading current should not be exceeded since the Pi network design is such that additional power input from a 700 volt supply will not result in additional power output. Above 300 ma. the efficiency of the NCX-3 final amplifier will be impaired and no further output will be obtained.

Proper operation of any linear final amplifier depends on proper idling current adjustment and on sufficient drive for adequate peak plate current during an off-resonance condition. The adjustment of the bias setting of the NCX-3 final amplifier is discussed under a separate bias adjustment paragraph. Assuming this setting has been made for an idling current between 50 and 60 ma., it should be possible to obtain a maximum off-resonance plate current in excess of 350 ma. with the NCX-3 final amplifier. As the PA TUNE control is rotated through the minimum current point (dip), the meter should indicate a definite rise to either side of the resonant point. If 700 volts is being properly supplied to the plate circuit of the final amplifier and the EXCITER TUNE control is properly adjusted, this off-resonance current should exceed 350 ma. If this current cannot be achieved, the cause should be investigated. Typical reasons may include any of the following: improper BIAS setting, improper EXCITER TUNE adjustment, low plate supply voltage to the final amplifier under full load conditions, low driver B+, defective final amplifier tubes, or improper operation of the exciter stages resulting in low driving signal.

As mentioned above, low plate supply voltage to the final amplifier will frequently result in difficulty in obtaining a suitable off-resonance current. The NCX-A power supply is rated to deliver 700 volts to the final amplifier with a 115 VAC input. The NCX-D power supply is rated to deliver 700 volts to the plate circuit of the final amplifier with a 12.0 volt input to the power supply. If the AC line voltage or the mobile

battery supply voltage are low, the power supply output will be reduced. Under these conditions, an off-resonance plate current of less than 350 ma. will probably occur. This will not impair the operation of the NCX-3 transceiver, provided the PA LOAD control is not adjusted for excessive loading conditions. In no event should the LOAD control be advanced so that the plate current at the resonant dip exceeds 85% of the off-resonant plate current, which is noted by detuning the PA TUNE control.

In many instances an antenna load will be presented to the NCX-3 which is outside the 40 to 60 ohm range of the Pi network of the NCX-3. Antennas presenting this type of impedance should, if at all possible, be adjusted to present a proper load at the NCX-3 antenna terminals. This can be done through the use of matching networks and in many instances through the simple expedient of tailoring the length of the antenna transmission line to modify its terminal impedance. Generally speaking, if the NCX-3 exhibits a resonant plate current in the dip in excess of 300 ma. with the PA LOAD control rotated to its full counter clockwise position, the antenna load impedance is below 40 ohms and cannot be suitably matched to the NCX-3. If, on the other hand, the resonant dip is still less than 300 ma. with the PA LOAD control rotated to its full clockwise position, the antenna load impedance is above 60 ohms. It is possible to modify the Pi network output capacitors of the NCX-3 to take care of some misloading in these directions. With the PA housing removed, a group of three mica capacitors will be seen just below the BAND switch and connected between the BAND switch and chassis. These capacitors C-4, C-3 and C-2 are respectively 220, 470 and 1200  $\mu\mu\text{f}$ . They appear in parallel with the front panel PA LOAD control as shown on the schematic diagram and may be altered to extend the range of the Pi network. If the load impedance is too low, the capacitance should be increased in size and if the antenna load is too high, the capacitance should be decreased in size. A good quality silver mica capacitor may be used for this purpose. It is advisable to use as large a case size on these capacitors as can be obtained.

There is, of course, some inter-action of tuning between the PA LOAD control and the PA TUNE control. If load matching, as described in the preceding paragraph, is attempted, it is possible that the tuning of the PA TUNE control will be shifted to a point where the control will no longer tune the entire amateur band. In this event, it will be necessary to achieve antenna match through the use of external matching techniques. It is also possible that the antenna line will present an inductive or capacitive component to the NCX-3 antenna terminals. In this event, there may also be a shift of the PA TUNE control so that it will not tune the entire amateur band. Again it will be necessary to alter the antenna impedance by means of an external matching network or correction of the antenna difficulties. SSB operation should not be at-

tempted unless the NCX-3 is properly matched and loaded since severe distortion can result with any improperly adjusted SSB transmitter or transceiver

### CARRIER BALANCE CONTROL

During tune-up conditions discussed under PA TUNE and PA LOAD control settings above, one deflection electrode of the 7360 balanced modulator is grounded providing for complete carrier unbalance. Having accomplished proper transmitter tune-up, it is necessary to use the CARRIER BALANCE control to properly set up the NCX-3 transceiver for operation on SSB, AM or CW operation. For SSB operation, the NCX-3 is placed in a transmit condition, either through use of the push-to-talk button or the VOX circuit. In either event, the MIC GAIN control should be in its full ccw position so that no audio modulation will occur. It is necessary to rotate the EXCITER TUNE control for maximum meter indication. The CARRIER BALANCE control is then adjusted for minimum cathode current meter indication. This meter reading should lie between 50 and 60 ma. if the BIAS control is properly adjusted. When the CARRIER BALANCE control is properly set, it may be left in this position for all subsequent single-side-band work. A more precise indication of CARRIER BALANCE control setting may be obtained through the use of an external oscilloscope connected to the antenna line or by listening to the carrier on a separate receiver. With proper carrier balance and tuning of the transceiver circuits, the indication on the antenna line should not exceed 0.5 volts peak-to-peak on the oscilloscope display.

For AM operation, it is necessary to adjust the CARRIER BALANCE control either cw or ccw from the balance point until the final amplifier cathode current meter indicates a final amplifier current of 150 ma. This corresponds to approximately 100 watts input to the final amplifier, thus assuring operation of the final amplifier tubes within their plate dissipation rating.

Finally, for CW operation, it is necessary to adjust the CARRIER BALANCE control either cw or ccw from its zero setting until a cathode current indication of 300 ma. is obtained. This assures an input to the final amplifier of 200 watts during key down transmit conditions of CW operation. Normal keying wave forms have approximately a 50% duty cycle; that is, there is full output for approximately  $\frac{1}{2}$  of the time and no power input for the remaining 50% of the time. Thus the Time-Averaged input to the final amplifier is still approximately 100 watts, assuring conservative operation of the final amplifier.

### MIC GAIN CONTROL

Assuming the NCX-3 has been set up for proper tuning of the final amplifier and exciter stages and the CARRIER BALANCE control has been properly set

for carrier balance, the MIC GAIN control should be advanced until the cathode current meter reads between 100 and 150 ma. average on speech content from the microphone. Occasional higher peaks, particularly on long-vowel syllables may be noted. The single sideband audio information so developed has a rapidly varying energy content and the cathode current meter will rapidly fluctuate between the 40 to 50 ma. idling current and the 100-150 ma. average meter reading. Actual peak current is approximately 300 ma. This fluctuation will be affected by the nature of the speech content, the individual voice, and the damping of the meter movement. Generally speaking, the meter indication will be higher for long drawn out vowel sounds than it is for crisp consonant sounds. Here again a more accurate setting of the MIC GAIN control can be made with an oscilloscope connected to the antenna line. To make this adjustment, the NCX-3 FUNCTION switch should be placed in the TUNE position and the oscilloscope adjusted to display the peak-to-peak power output level. This level should be noted or marked on the oscilloscope face. The FUNCTION switch is then returned to the SSB position and the MIC GAIN control is advanced until the peaks of the SSB wave form illustrated in figure 5-J of the Test and Alignment instructions just reach the previously-marked oscilloscope level. It will be noted that any additional advance of the MIC GAIN control will cause clipping of the peaks of the SSB wave form. There will be a corresponding increase in the average power output under this condition of mis-adjustment, but this clipping action will result in the generation of unwanted spurious signal information (or "splatter") outside of the NCX-3 passband and should be avoided.

For AM operation with the CARRIER BALANCE control set as recommended above, there will be a steady meter reading of 150 ma. As the MIC GAIN control is advanced during speech, AM modulation of the final amplifier will occur. When the MIC GAIN control setting reaches a point where the cathode current meter just indicates a slight flicker of speech peaks, modulation is 100%. Operation of the MIC GAIN control above this setting should not be used since excessive drive will cause clipping of the modulated envelope and will result in unwanted spurious information outside of the passband of the NCX-3.

### CALIBRATOR CONTROLS

When the accessory XCU-27 100 KC calibrator is plugged into the octal socket on the rear apron, 100 KC crystal markers are available for precise calibration of the NCX-3. The calibrator is activated by means of a push-pull switch (on series 48 and higher transceivers) on the microphone gain control. *PULL* to turn calibrator on.

### AUDIO AND RF GAIN CONTROLS

Little need be said about the operation of the AUDIO GAIN and RF GAIN controls. The AUDIO GAIN control is adjusted for comfortable listening level in the loud speaker or ear phones. The RF GAIN control may be set to individual operator preference with the exception that the S-meter reading will be a function of the RF GAIN control setting.

Normal operation of the NCX-3 S-meter is obtained with the RF GAIN control set in its full cw position.

### S-METER ADJUSTMENT

Proper S-meter adjustment of the NCX-3 is obtained by disconnecting the antenna with the NCX-3 set for SSB reception and the RF gain fully cw. The S-meter adjustment is rotated until the meter indicates between 0 and 1 "S" unit on the S-meter. When the antenna is reconnected, the S-meter will indicate the signal strength of incoming signal or background noise on the antenna circuit.

### VOX-PTT SWITCH AND VOX CIRCUIT ADJUSTMENTS

The VOX-PTT switch is located on the rear panel. It may be set to either mode of operation depending on individual operator preference or whether or not the microphone is equipped with a push-to-talk button. Proper microphone jack connections are illustrated in figure 1.

Assuming that VOX operation is selected, the operator will find that the VOX SENSITIVITY and VOX DELAY control settings of the NCX-3 are remarkably free from interaction. The extreme VOX sensitivity available in the NCX-3 permits full anti-vox insertion at all times. As a result no control potentiometer is required. The VOX SENSITIVITY control is advanced slowly until the microphone just trips with normal speaking level. Mobile operation at this level should be set for close talk to the microphone since the high level of road, wind and motor noises will otherwise tend to accidentally trip the VOX circuit. The VOX DELAY control is then adjusted for the desired release time. Release time in the order of 1/10 of a second will be obtained in the full cw position of the VOX DELAY control and in the order of a second or more in the full cw position of the VOX DELAY control.

It should be further noted that PTT and CW break-in operation is obtained through use of the VOX circuit. However, the VOX SENSITIVITY control will have no effect on this operation and may be left in any position. The VOX DELAY control is effective on both PTT and CW break-in operation and should be adjusted to the operator's individual preference for delay at the end of the keying sequence or upon release of the PTT button.

## TEST AND ALIGNMENT

### NOTE

TEST AND ALIGNMENT OF THE NCX-3 SHOULD ONLY BE PERFORMED BY COMPETENT, QUALIFIED PERSONNEL.

### EQUIPMENT REQUIRED

1. Signal generator providing output at the following frequencies: 5.202 mc., 3.5 mc., 4 mc., 7 mc., 7.3 mc., 13.9 mc., 14.4 mc.
2. Vacuum tube voltmeter (VTVM)
3. Standard audio output meter.
4. Sweep generator capable of sweeping at approximately 1 cycle per second over a frequency range from approximately 5 to 5.5 mc.
5. Long persistence oscilloscope equipped with low capacity detector probe and having a frequency range from DC to low audio frequencies.
6. High frequency oscilloscope covering the range from DC to 30 mc. with a maximum sensitivity of 50 mv. per centimeter or better and having a low capacity input probe. (Tektronix type 541 with type L pre-amplifier or equivalent.)
7. 50 ohm dummy load with calibrated output power meter covering the frequency range from 3.5 to 14.4 mc. (A high frequency vacuum tube volt meter with a 100 volt full scale range may be substituted for the calibrated output power meter.)
8. Power supply capable of supplying +700 volts at 300 ma., +280 volts at 125 ma., and -80 volts at 6 ma. with provisions for switching off the 700 volt output.
9. Grid dip meter operating at 4.7 and 14.4 mc.
10. 1000 cycle audio generator with an output level of 10 mv.
11. High quality microphone equipped with push-to-talk button.
12. Transmitting key.
13. Suitable alignment tools for adjustment of coils and capacitors.

### INITIAL CONTROL SETTINGS

#### FRONT PANEL

MIC GAIN ..... Full ccw  
 CARRIER BALANCE ..... Full ccw or cw  
 RF and AUDIO GAIN ..... Full cw  
 FUNCTION switch ..... OFF  
 PA TUNE ..... Full cw  
 PA LOAD and EXCITER TUNE ..... Full ccw  
 BAND switch ..... 80 meters

#### REAR PANEL

VOX-PTT Switch ..... PTT  
 VOX SENSITIVITY ..... Full ccw  
 VOX DELAY ..... Mid-range  
 BIAS ..... Mid-range

### POWER CONNECTIONS

Connect the power supply with the 700 volt output

turned OFF. The heater wire connecting the two 6GJ5 sockets should be removed. The crystal filter crystals should be removed.

### IF ALIGNMENT PROCEDURE

With the grid dip meter set to 5.1 mc., bring the probe into proximity of the crystal filter coil L19. Adjust the slugs of the crystal filter coil to resonance as indicated on the grid dip meter. (Take care not to couple too tightly to L19 in order to avoid frequency pulling of the grid dip meter.) Now install the crystal filter crystals. Then turn the FUNCTION SWITCH to SSB. In a few seconds, the relay should close indicating that the NCX-3 is in a receive condition. Suitable resistance and voltage checks should be made to insure proper operation.

Connect the audio output meter to the speaker leads by plugging the audio output meter into the phone jack. Connect the signal generator through a 1000  $\mu$ mf capacitor to the grid (Pin 7) of the 6BE6 receive mixer. Set the signal generator for output at 5.202 mc. A 1 to 2 kc beat note should be heard. Align the slugs of the filter output can (T2) and the 1st, 2nd and 3rd IF transformers (T3, T4 and T5) as well as the bottom slug of the balanced modulator transformer (T1) for maximum output. The signal generator output should be reduced throughout this alignment procedure so that an output of 100 milliwatts is never exceeded.

### BALANCED MODULATOR ADJUSTMENT

Connect the high frequency oscilloscope to the junction of C59, C60, X1, and X3 at the filter input. Insert a microphone into the front panel microphone jack. Depress the push-to-talk button. The relay in the NCX-3 should open, placing the unit in a transmit condition. Adjust the top slug of the balanced modulator transformer for maximum indication on the scope. Carefully adjust the front panel CARRIER BALANCE control for minimum indication on the scope. This should occur near mid range of the control. Carefully adjust the balanced modulator plate trimmer C107 for minimum indication while rocking the front panel CARRIER BALANCE control through the null. After adjustment, the scope peak-to-peak display should indicate less than 10 mv. peak-to-peak when the CARRIER BALANCE control is set for minimum and more than 1.5 volts peak-to-peak when the control is set full cw and ccw. Adjust knob on shaft so that null occurs at 12:00 index.

### CRYSTAL FILTER ALIGNMENT

Connect the high frequency oscilloscope to the grid (Pin 1) of the 12BA6 second IF amplifier. Continue to hold down the push-to-talk button, keeping the unit in a transmit condition. Adjust the top and bottom slugs of the balanced modulator transformer (T1) and

the slug of the filter output can (T-2) for maximum indication on the oscilloscope. Extreme care should be used to insure that these adjustments are precisely made since care in these adjustments will result in less difficulty in the following sweep generator checks.

Release the push-to-talk button; the relay of the NCX-3 should close indicating a return to receiving condition. The display on the oscilloscope should disappear as the relay clicks. Remove the high-frequency oscilloscope connection and the signal generator connection. Set the function switch to AM. Attach the output of the 5 mc. sweep generator to the grid (Pin 7) of the 6BE6 receive mixer. Connect the low frequency oscilloscope probe to the junction of C78, C87, D1, and D2. With the sweep generator output set for approximately 500  $\mu$ v., the oscilloscope display should indicate a filter curve with a shape similar to that indicated in figure 5-A. The slug of the filter output coil (T2) should be slowly withdrawn from the coil to elevate the right-hand side of the display. If the display indicates excessive peak-to-valley excursions, or "ripple", the top slug of the balanced modulator transformer (T1) should be carefully adjusted to minimize this ripple as indicated in figures 5-B and 5-C. The bottom slug of the balanced modulator transformer (T1) may be slightly adjusted to correct tilt in the filter curve. With proper alignment, the resulting curve should look like figure 5-D.

A check should now be made for IF regeneration by observing the filter curve. Increase the sweep generator input by 20 db and reduce the RF gain to obtain the same amplitude of oscilloscope display. There should be no major change in the shape of the curve which results.

### CARRIER OSCILLATOR SETTING

Note the DC level of the top of the filter curve now being displayed on the oscilloscope. Return the RF gain control to maximum gain and stop the sweep generator. Manually adjust the sweep generator frequency until the oscilloscope spot comes down the display curve to the level noted, being careful that this level is obtained on the low frequency side of the filter curve. The frequency of the sweep generator is now accurately set to a point 20 db down the carrier slope. Place the FUNCTION switch in the SSB position. At this point the spot on the oscilloscope display should become a vertical line indicating the presence of a beat note. Slowly adjust the carrier oscillator trimmer for zero beat as indicated by a slow visible vertical oscillation of the spot.

This completes the alignment of the receiver IF, the crystal filter and the carrier oscillator. The sweep generator and oscilloscope connections may now be removed.

### VFO FREQUENCY ALIGNMENT

Connect the high frequency signal generator to the antenna terminals of the NCX-3. Set the signal generator frequency for 4 mc. Set the main tuning dial

for 4 mc. Adjust the 80 meter coil (L16) for zero beat. Now set the signal generator input for 3.5 mc. and tune the main tuning dial toward 3.5 mc. A beat note should be obtained in the region of 3.5 mc. on the dial. If this beat note occurs at a dial setting above 3.5 mc., the 80 meter trimmer (C40) should be turned in a direction to increase capacity. If the beat note occurs below 3.5 mc. on the dial, decrease the trimmer capacity. Return the signal generator and main dial to 4 mc. Repeat the 80 meter coil slug for zero beat and again observe the location of the beat note near 3.5 mc. with the input generator set to 3.5 mc. Repeat this procedure until the 3.5 mc. beat note occurs at the 3.5 mc. dial marking with the 4 mc. setting exactly at zero beat.

With the input signal generator set at 4 mc., tune for zero beat with the main tuning dial. Switch the signal generator input to 14.4 mc. and switch the BAND switch to 20 meters. A beat note should be observed indicating correct alignment of the 20 meter band. The difference in beat note between 80 and 20 meters as the BAND switch is changed should not exceed 2 kc. Repeat this test at 3.5 and 13.9 mc. Again the difference in the beat note should not exceed 2 kc. There is no alignment adjustment for correction of error in this band-switching process. If this beat note does exceed 2 kc., it will be necessary to trouble-shoot the band-switching circuits of the VFO.

Set the signal generator to 7.3 mc. and the main tuning dial to 7.3 mc. and the BAND switch to 40 meters. Adjust the 40 meter coil (L15) for zero beat, set the signal generator to 7 mc. and tune the main tuning dial and observe the location of zero beat. Repeat the process used on the 80 meter band, adjusting the 40 meter trimmer (C38) for alignment of the 7.3 and 7.0 mc. points. Remove the signal generator.

### TRANSMIT MIXER AND DRIVER ALIGNMENT

Connect the high frequency oscilloscope to the junction of C23, R3, R4 and R7 in the grid circuit of the 6G15 final amplifier. Set the BAND switch to 80 meters and the FUNCTION switch to tune. The relay should again drop out indicating that the unit has been placed in a transmit condition. Set the main tuning dial to 3.5 mc. and the EXCITER TUNE control to 1. Adjust the 80 meter mixer coil (L11) and the 80 meter driver coil (L7) slugs for maximum indication on the oscilloscope. When the slugs are properly adjusted, the peak-to-peak output voltage on the oscilloscope should exceed 100 volts. Set the main tuning dial to 4.0 mc. and rotate the EXCITER TUNE control clockwise until a maximum is reached on the oscilloscope presentation. At this setting, the scope should indicate in excess of 100 volts peak-to-peak. A compromise may be made with the settings of the mixer and driver slugs to achieve proper tuning at both ends of the band while remaining within the range of the EXCITER TUNE control, and still satisfying the requirement that more than 100 volts peak-to-peak be available at both extremes.

Set the BAND switch to 40 meters and repeat the above procedure at 7.0 and 7.3 mc. while adjusting the 40 meter mixer coil (L12) and the 40 meter driver coil (L8). Again both points must be within the normal range of the EXCITER TUNE control and an output of more than 100 volts peak-to-peak must be indicated on the oscilloscope at both frequencies.

Set the BAND switch to 20 meters and repeat the above procedure at 13.9 and 14.4 mc. while adjusting the 20 meter mixer coil (L13) and the 20 meter driver coil (L9). In this instance, the EXCITER TUNE control should be set to 4 for the low frequency adjustment at 13.9 mc.

This completes the adjustment of the mixer and driver stages with the exception that a slight misalignment now exists in the driver coil due to the presence of the oscilloscope probe during the previous adjustments and measurements. This error will be corrected during testing of the final amplifier stages to be described later.

### ADJUSTMENT OF THE NEUTRALIZING CAPACITOR

With the high-frequency oscilloscope still connected to the grids of the final amplifier and the BAND switch remaining at the 20 meter band, the frequency of the main tuning dial should be set to approximately 14.2 mc. Set the EXCITER TUNE control for maximum indication on the oscilloscope. Now set the FUNCTION switch to the OFF position. This should remove all power from the NCX-3. Set the grid dip meter to 14.2 mc. and bring it into proximity of the final tank coil, and then increase the sensitivity of the high-frequency oscilloscope. A signal should appear on the grid of the 6GJ5 tubes and should be visible on the oscilloscope. Adjust the neutralizing capacitor C17 for a minimum indication on the oscilloscope. This will result in an approximate neutralizing capacitor adjustment. A final adjustment will be made in the final amplifier checks immediately following.

### FINAL AMPLIFIER TUNING CHECKS

The NCX-3 construction does not provide for any alignment of the final amplifier. However, it is necessary at this time to check the final amplifier for proper operation at the high and low ends of all bands. In addition, it is necessary to make a slight final adjustment on the driver plate coils and on the neutralizing capacitor. These checks should be made in the following sequence:

1. Connect the heater wire between the two 6GJ5 sockets.
2. Place the FUNCTION switch in the CW position and allow approximately 30 seconds for warm-up of the final amplifier tubes.

### CAUTION

UP TO THIS POINT, THERE HAS BEEN NO POWER APPLIED TO THE FINAL AMPLIFIER. ALL CIRCUITS WHICH HAVE BEEN OPERATING

AND WHICH HAVE BEEN TESTED ARE LOW LEVEL, COMPARATIVELY LOW VOLTAGE CIRCUITS. FROM HERE ON VOLTAGES AND CURRENTS ARE PRESENT WHICH ARE DANGEROUS TO PERSONNEL, TO THE TEST EQUIPMENT, AND THE UNIT UNDER TEST. IT IS ESSENTIAL TO BE SURE THAT NO PIECE OF TEST EQUIPMENT IS MIS-CONNECTED TO THE NCX-3. IT IS FURTHER IMPORTANT THAT PERSONNEL BE CAUTIONED AGAINST CARELESS HANDLING WHICH MAY RESULT IN PERSONAL CONTACT WITH DANGEROUS VOLTAGES, AND THAT THE NCX-3 NOT BE PLACED INTO A TRANSMITTING CONDITION WITHOUT PROPER TUNING SINCE DAMAGE TO THE NCX-3 MAY RAPIDLY RESULT. IN A NUMBER OF THE FOLLOWING TESTS, THE TRANSMITTER WILL BE OPERATED AT FULL POWER OUTPUT. IT IS IMPORTANT THAT THE UNIT BE RETURNED TO A RECEIVING CONDITION IF MIS-INDICATIONS ARE OBTAINED, OR IF THE TEST IS NOT COMPLETED WITHIN A PERIOD OF 15 SECONDS, OR IF THE UNIT IS NOT TUNED UP WITHIN A PERIOD OF 15 SECONDS. OTHERWISE, SERIOUS AND PERMANENT DAMAGE MAY OCCUR IN THE FINAL OUTPUT CIRCUIT.

Disconnect all test equipment from the NCX-3. Attach the 50 ohm dummy load with calibrated output meter to the NCX-3 antenna terminals. With a DC voltmeter, set the bias at the grid of the final amplifier to -45 v. Apply 700 volts from the power supply to the plate circuit of the final amplifier. With the BAND switch still on the 20 meter band, set the main tuning dial to 14.4 mc. Now turn the FUNCTION switch to TUNE and rapidly peak the EXCITER TUNE for maximum meter reading on the combination S-meter and cathode current meter. Adjust the 20 meter driver plate coil (L9) for maximum meter reading while slowly rocking the EXCITER TUNE control. This will correct for the presence of the oscilloscope probe in the previous setting. Now rotate the PA TUNE control and observe whether a dip occurs in the plate current reading.

It is now necessary to check the final setting of the neutralizing capacitor. Note the current reading of the dip. If it is less than 300 ma., rotate the PA LOAD control in a cw direction while retuning the PA TUNE control to maintain tuning to the plate current dip. Continue this process until an input current of 300 ma. is obtained. Rotate the PA TUNE control to either side of the resonant point and observe the plate current meter. It is necessary that the off-resonance current exceed 350 ma. Having noted the off-resonance plate current, return the PA TUNE control to the plate current dip at 300 ma. and observe the power output, which should exceed 120 watts. Carefully rotate the PA TUNE control to either side of the dip and observe whether the power output rises or falls. With proper setting of the neutralizing capacitor, the power output should decrease on either side of the dip. If the power output actually rises as

the tuning control is tuned away from the dip, it will be necessary to slightly readjust the neutralizing capacitor. This can be quickly done on a trial and error basis by introducing a slight rotation into the neutralizing capacitor and observing whether maximum power output occurs at the plate current dip. As proper neutralization is achieved, maximum power output will occur at minimum plate current. The neutralizing capacitor should be left at this setting for all subsequent tests.

A tuning check at full power should be made at 14.4, 13.9, 7.3, 7.0, 4.0 and 3.5 mc. At each frequency the PA TUNE control is set for a plate current dip and the PA LOAD control is slowly rotated in a clockwise direction. As the PA LOAD control is advanced, it will be necessary to slightly retune the PA TUNE control to stay in the dip. Continue this process until the minimum reading in the dip corresponds to 300 ma. on the meter. The power output should exceed 120 watts at all frequencies when the NCX-3 is loaded to 300 ma. in the plate current dip.

If a proper dip can be obtained at the extremes of each band and within the range of the PA LOAD control, we can assume that the final amplifier is tuning properly. Returning the FUNCTION switch to the CW position should close the relay, indicating a return to a receiving condition. We have now established that we have a properly functioning final amplifier for CW power. We have made no checks on the dynamic operation of the transmitter. These checks will be made using a 1000 cycle audio tone.

### **MODULATION, CARRIER SUPPRESSION, SIDEBAND SUPPRESSION AND OVERLOAD CHECKS**

Connect the audio generator to the microphone jack and supply 10 mv. of audio signal to the NCX-3. Rotate the FUNCTION switch to the SSB setting, connect the high frequency oscilloscope to the antenna line which is connected to the dummy load. Close the PTT circuit to place the NCX-3 in a transmit condition. Rotate the CARRIER BALANCE control full cw or full ccw. Tune the final amplifier for maximum output at 300 ma. input, as described in the previous sections. A level well in excess of 100 volts peak-to-peak should be noted on the oscilloscope. Now, slowly rotate the CARRIER BALANCE control toward midpoint. The oscilloscope level and the cathode current meter reading should fall. Set the CARRIER BALANCE control for minimum indication on the oscilloscope which should correspond with a minimum indication on the cathode current meter. Adjust the BIAS control for 50 to 60 ma. on the meter. The level remaining on the oscilloscope should not exceed 0.5 volt peak-to-peak thus assuring a carrier balance in excess of 50 db.

To check for proper sideband suppression, rotate the MIC GAIN control slowly in a clockwise direction. A signal should again appear on the oscilloscope. The MIC GAIN should be advanced until the signal

reaches 150 volts peak-to-peak. The cathode current meter should, at this point, indicate a current in the region of 250 ma. The wave form at this point should appear as indicated in figure 5-E. It is necessary to note the level of ripple on the wave form relative to the total wave form level. The ripple should not exceed 1/50 of the total wave form.

It is important to note the difference between carrier balance and unwanted sideband suppression in the previous measurement. If the CARRIER BALANCE control is rotated ever so slightly, the wave form of figure 5-E will be altered to the wave form of figure 5-F. If this wave form is present while attempting to make the sideband suppression measurement, the CARRIER BALANCE control should be slightly adjusted in order to compensate and return the wave form to that of figure 5-E.

Now, further advance the MIC GAIN until the cathode current meter just reaches 300 ma. as set by our previous tune-up procedure. Note the oscilloscope level. Slowly advance the CARRIER BALANCE control either cw or ccw from the balance setting. As this occurs, the wave form will begin to develop large cusps and peaks which will tend to exceed the noted oscilloscope level. Slowly reduce the MIC GAIN. By carefully adjusting between the MIC GAIN and the CARRIER BALANCE control keep the peaks at the pre-determined level. It should be possible to obtain a picture as illustrated in figure 5-G. It is important that the peaks of this figure be exactly at the level determined with the balanced carrier at 300 ma. of the cathode current. This is equivalent to a two-tone test and is useful in indicating distortion in the transmitter channel and performance of the modulating circuits. The wave form which is observed should have a clean sharp cusp and should have a sine wave envelope. There should be no flattening of the peaks and no broadening of the cusps. Typical *incorrect* wave forms are indicated in figure 5-I.

If all tests are completed satisfactorily, we can assume that the transmitter is working properly, although it is of value to check the dynamic operation of the transmitter with speech information. To do this, return the MIC GAIN to zero and balance the carrier with the CARRIER BALANCE control. Now, remove the audio generator from the microphone jack and replace it with the test microphone. Press the push-to-talk button and speak normally into the microphone. Slowly advance the MIC GAIN control until the peaks of the resulting signal reach the amplitude used for the previous two-tone type of test. At this point, the cathode current meter will be fluctuating rapidly with the speech content. The current meter should generally average around 100 ma. of current and the output wave form should appear as illustrated in figure 5-J.

### **SWITCHING TESTS**

The transmitter portion of the NCX-3 is presently connected to a dummy load with an oscilloscope and is tuned to resonance for maximum power output.



With these conditions established, check the entire switching sequence in the following manner:

1. Place the FUNCTION switch in SSB and the PTT-VOX switch in the PTT position. Press the push-to-talk button and speak into the microphone. A standard SSB output should appear on the oscilloscope. The NCX-3 should make a noiseless transition from receive to transmit. Release the push-to-talk button. The NCX-3 should revert to receive.

2. Place the VOX-PTT switch in the VOX position. While speaking into the microphone, slowly advance the VOX SENSITIVITY control until the relay trips the unit into transmit. This transition should be noiseless except for the click of the relay. Stop speaking and the transmitter should return to receive.

3. Speak into the microphone to cause the NCX-3 to transmit and adjust the VOX DELAY control full ccw. Stop speaking and the NCX-3 should go back to receive in approximately 1/10 of a second.

4. Turn the VOX DELAY control full cw and speak into the microphone. The NCX-3 should switch to transmit; stop speaking and the NCX-3 should return to receive in two to three seconds. In each case, a standard SSB signal should be observed on the oscilloscope while speaking into the microphone.

5. Set the FUNCTION switch to AM and repeat the above tests for PTT and VOX operation.

6. While speaking into the microphone, adjust the CARRIER BALANCE control from the null point and observe on the oscilloscope the introduction of carrier into the side-band signal.

7. Place the FUNCTION switch in the CW position. Advance the VOX SENSITIVITY control full cw (maximum sensitivity). Speaking into the microphone in this condition should *not* result in transmit-receive switching.

8. Set the VOX-PTT switch to PTT and press the PTT button. The NCX-3 should *not* switch into transmit.

9. Insert a key into the key jack. A tap of the key should place the NCX-3 into a transmit condition. Upon release of the key, the unit should revert to receive in 1/10 of a second to 2 or 3 seconds depending on the setting of the VOX DELAY control.

10. Hold the key closed, speak into the microphone and advance the MIC GAIN control. There should be no evidence of modulation on the oscilloscope.

11. Set the transmitting key for a long series of dots. Adjust the CARRIER BALANCE control for transmitter output just below full power. Observe the series of keying pulses on the high-frequency oscilloscope. A proper keying pulse should appear as in figure 5-K. Figure 5-L and 5-M indicate improper keying sequences.

12. Set the FUNCTION switch to TUNE. Observe that full power output is attained on the oscilloscope. Adjusting the CARRIER BALANCE control should produce no change in the output signal.

13. Speak into the microphone and advance the MIC GAIN control. There should be no evidence of modulation on the oscilloscope.

## CAUTION

IN THE FOLLOWING SERIES OF TESTS, THERE IS NO LOAD ON THE TRANSMITTER OUTPUT. IF THE UNIT SHOULD GO INTO TRANSMIT UNDER THIS CONDITION, SERIOUS DAMAGE MAY OCCUR IN THE FINAL OUTPUT STAGE AND TO THE SIGNAL GENERATOR WHICH WILL BE CONNECTED TO THE ANTENNA TERMINALS.

## SENSITIVITY MEASUREMENTS

With the RF GAIN control in the full cw position, reduce the signal generator input to the region of 1  $\mu$ v. Tune the NCX-3 for a beat note of approximately 1000 cycles and peak the EXCITER TUNE and PA LOAD Controls. Switch the signal generator output on and off and observe the change in the audio output meter reading. Adjust the signal generator input until the audio output meter rises 10 db when the signal generator is turned on. The resulting signal generator output is the receiver sensitivity. Sensitivity figures should be less than 1  $\mu$  volt at all frequencies.

Rotate the RF and AUDIO GAIN controls full ccw, set the S-meter adjust control R25 for zero on the S-meter scale.

## S-METER ZERO ADJUST

Rotate the RF and AUDIO GAIN controls full ccw, set the S-meter adjust control R25 for zero on the S-meter scale.

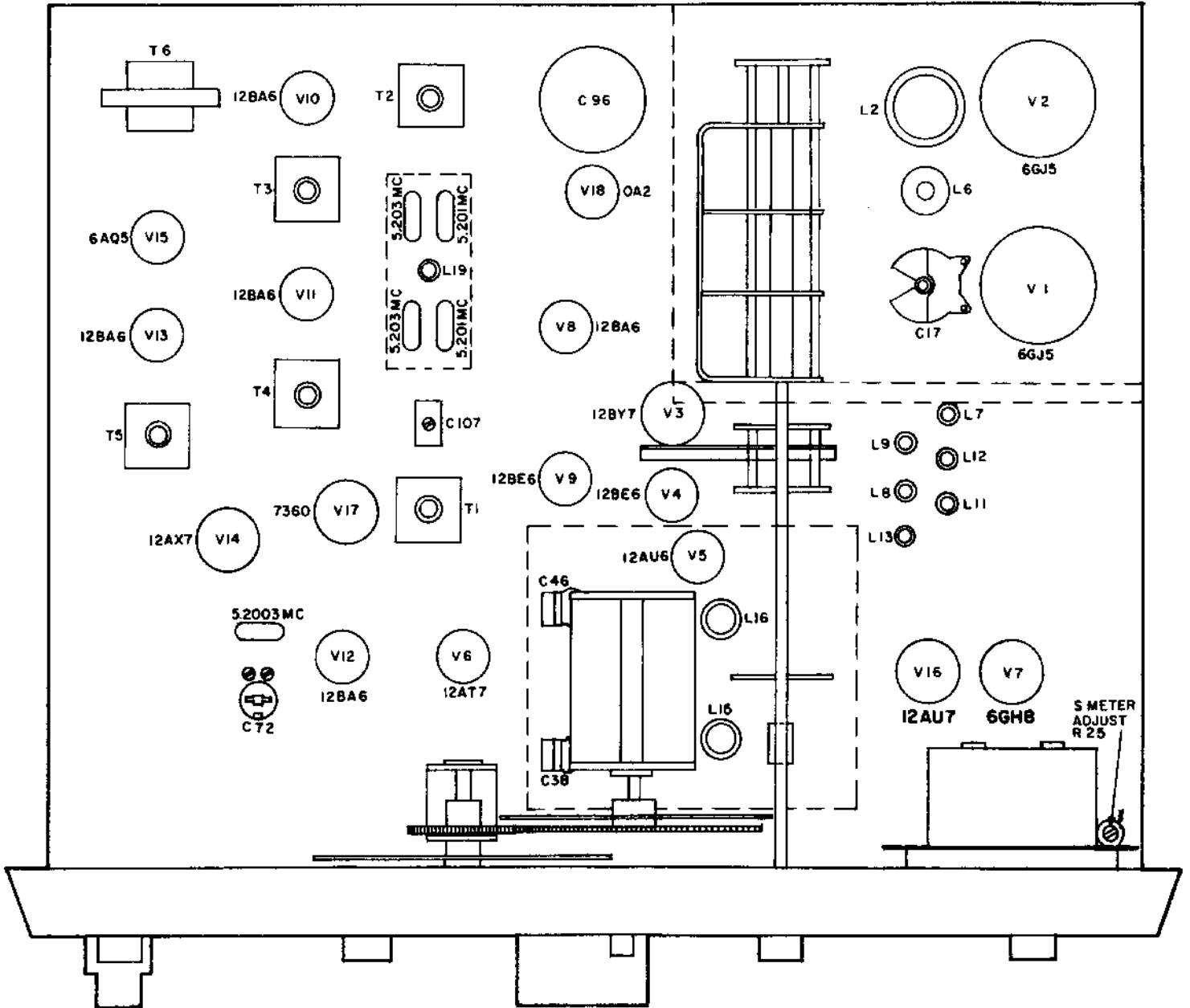

Figure 3. NCX-3 Chassis Layout, Top View

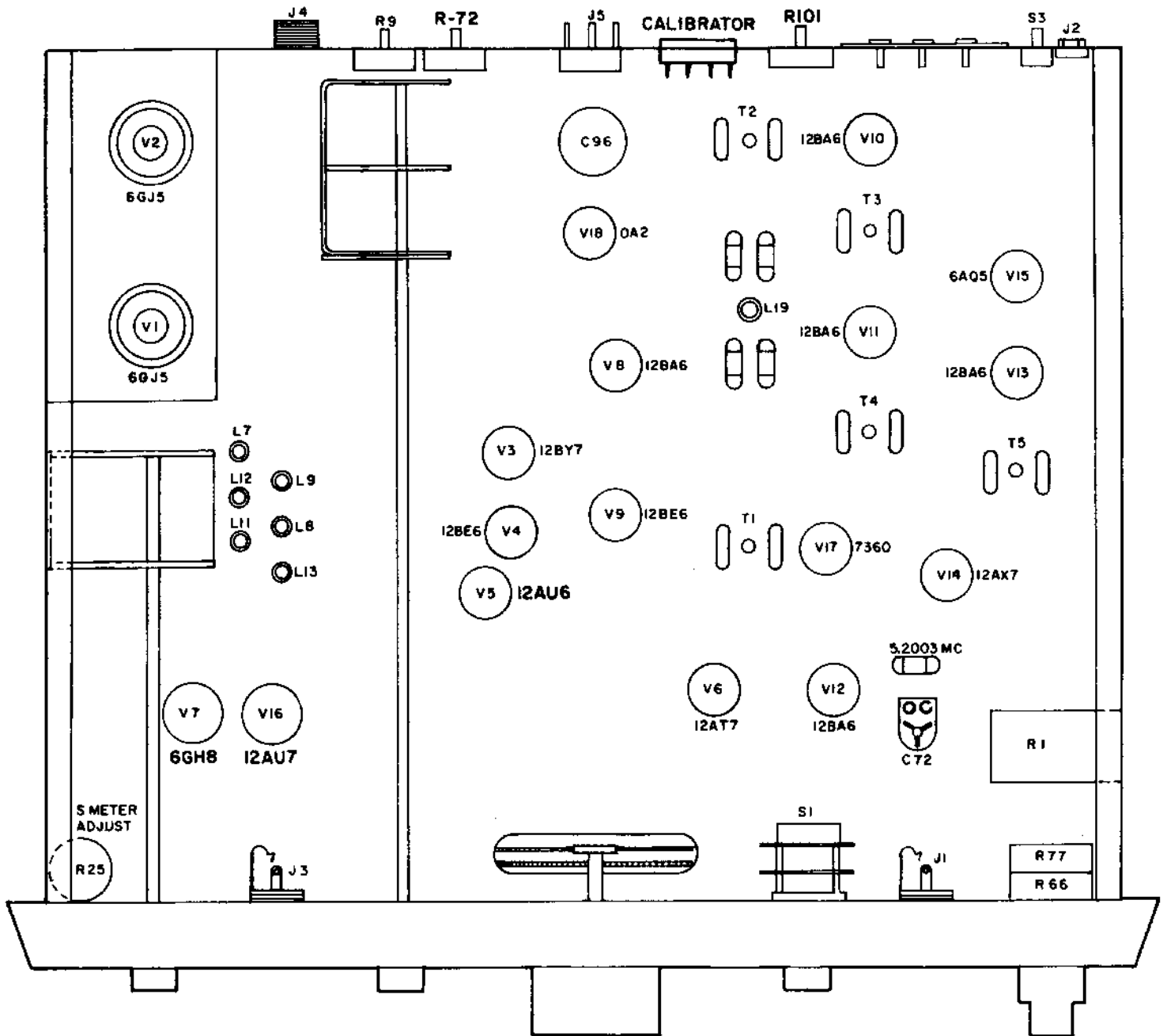

Figure 4. NCX-3 Chassis Layout, Bottom View

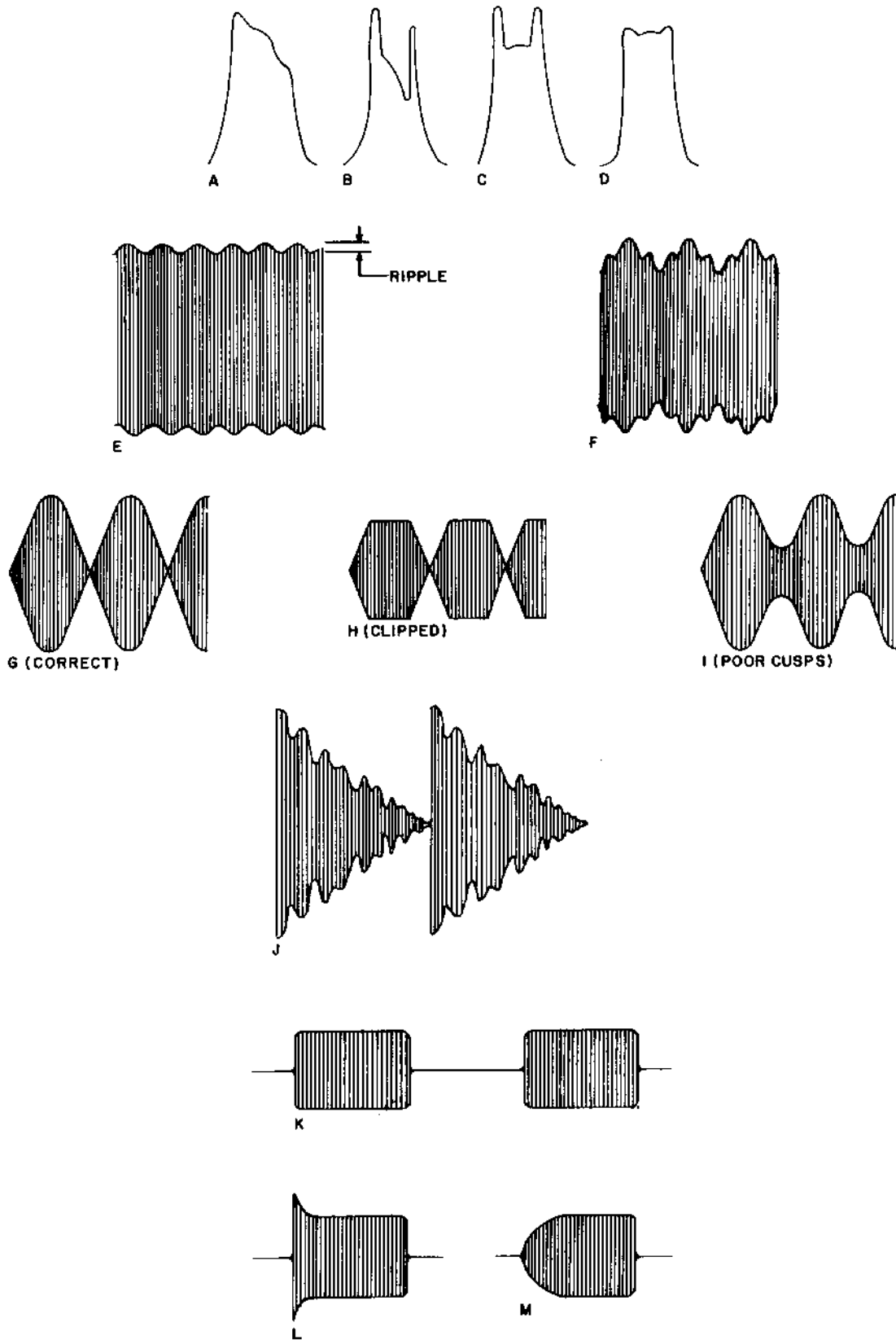

Figure 5. NCX-3 Wave Forms

## PARTS LIST

ALL READILY AVAILABLE RESISTORS AND CAPACITORS ARE OMITTED FROM THE FOLLOWING PARTS LIST, BUT ARE COMPLETELY IDENTIFIED ON THE SCHEMATIC.

DESCRIPTION	PART NUMBER	DESCRIPTION	PART NUMBER
Socket-Relay	A-50954	Capacitor—Ceramic 500 $\mu$ f $\pm 10\%$	A-50849-5
Socket-Octal	B-27674-1	Capacitor—Ceramic 0.01 $\mu$ f 1 KV $\pm 20\%$	A-50849-6
Socket, 9 Pin	B-27668-1	Capacitor—Ceramic 200 $\mu$ f Zero Coef $\pm 2\%$	A-50113-3
Transformer — Audio	B-19435-2	Capacitor—Ceramic 120 $\mu$ f Zero Coef $\pm 2\%$	A-50113-2
Trimmer Ceramcon (Carrier Osc.)	B-19783-2	Capacitor—Ceramic 15 $\mu$ f N750 $\pm 5\%$	CC 20-UJ-150-K
Plug, Power	A-50791	Capacitor—Ceramic 15 $\mu$ f N470 $\pm 5\%$	CC 20-TH-150-K
Trimmer — Mica (Balanced Modulator)	A-50137	Diode, 1N462	A-50832
Switch VOX-PTT	B-50457-14	Diode, 1N459	A-50893
Strip — relay terminal	A-12614-2	Window	A-50841
Capacitor, Electrolytic	C-19458-6	Window Pinch Assembly	A-50842
Potentiometer, MIC GAIN	B-50986	U-Frame Assembly	B-50819-2
Potentiometer, CARRIER BALANCE	B-50768-2	Shaft Dial	A-50820
Potentiometer, (Dual), RF-AF GAIN	B-50746	Dial	A-50821
Switch, Function	A-50792	Dial and Hub Assembly	
Potentiometer, S-Meter	B-50541-3	Drive Gear — Dial	A-50824
Potentiometer, VOX SENS	B-50541-2	Tube, 6GJ5	6GJ5
Potentiometer, BIAS	B-50541-1	Tube, 12BY7	12BY7
Potentiometer, VOX DELAY	B-50541-4	Tube, 12BE6	12BE6
Jack, key, 2 ckt.	A-50793-1	Tube, 12BA6	12BA6
Jack, Microphone, 3 ckt.	A-50793-2	Tube, 12AU6	12AU6
Jack, sht. phones, 2 ckt.	A-50793-3	Tube, 6AQ5	6AQ5
Connector, Antenna	B-27680	Tube, 12AX7-A	12AX7-A
Capacitor, Variable, EXCITER TUNE	C-50790	Tube, 12AU7	12AU7
Capacitor, Variable, PA LOAD	C-50788	Tube, 6AN8	6AN8
Capacitor, Variable, PA TUNE	C-50789	Tube, 7360	7360
Wafer, (PA BAND switch)	A-50786	Tube, OA2	OA2
Capacitor, Neutralizing	B-50864	Tube, 12AT7	12AT7
Capacitor, Variable (VFO)	C-50787	Lamp, Panel	NPL47
Gear Assembly	B-50796	Lamp Socket Assembly Panel	B-50829
Disk Drive	A-50794	Crystal—5203 Carrier Oscillator	A-50769
Trimmer — Ceramic (VFO)	B-19783-4	Crystal—5.201 Filter	A-50767-1
BAND switch (VFO Section)	B-50783	Crystal—5.203 Filter	A-50767-2
Shaft, (BAND switch)	A-50854	Plug, Jones, Female	A-50828
Coupling (BAND switch)	A-12611	Cover, VFO	C-50826
Relay, (Xmit-receive)	A-50798	Assembly Front Panel	E-50810-4
Socket, Xtal	A-50799	Meter—I ma.	C-50833
Coil, Mixer, 20 Meter	B-50760	Knob, Main Tune—#17 with Aluminum Cap.	NPS-D-17-2-L-A
Coil, Mixer, 40 Meter	B-50758	Knob—Dial Skirt—#7 with Aluminum Cap.	NPS-F-7-2-L-A
Coil, Mixer, 80 Meter	B-50756	Knob—#7 with Aluminum Cap and Dot	NPS-N-7-3-L-C
Coil, Driver, 20 Meter	B-50759	Knob Special	B-50901-1
Coil, Driver, 40 Meter	B-50757	Cover—P.A.	C-50815
Coil, Driver, 80 Meter	B-50755	Cover—Filter	B-50855
Coil — Xtal filter	B-50763	Knob—Aluminum Cap with Dot	NPS-D-7-2-L-C
Coil, VFO (80-20 M)	B-50751	Shaft, PA TUNE	A-50818-1
Coil, VFO (40 M)	B-50752	Shaft, EXCITER	A-50818-2
Transformer, Balanced Modulator	B-50764	Shaft, PA LOAD	A-50818-3
Transformer, Filter Output	B-50765	Coupling	B-25000
Transformer, IF	B-50766	Bushing, Panel	A-50840
Coil — PA Choke	B-50816	Assembly Cabinet	E-50812-8
Coil (Pi Network)	B-50753	Extension Foot	A-50850
Choke — Parasitic	B-50754	Foot—Rubber	A-50851
Cap Plate	SA 91-F-4	Bushing—Mobile Mounting Bkt	A-50817
Choke 220 $\mu$ h	A-50206	Nuts—Mobile Mounting Bracket	A-50117-8
Choke — Heater	C-50747-2	Mobile Mounting Bracket	B-50836
Choke — Antenna	C-50523-3	Bracket—Screws	A-50835
Resistor, 3.2 ohms 2 watt $\pm 3\%$	B-17436-10	Bracket—Pins	A-50860-1
Resistor, 2.5K 5 watt $\pm 10\%$	B-17436-11		
Resistor, 1000 ohms 10 watt $\pm 10\%$	B-17436-12		
Capacitor—Ceramic 10 $\mu$ f { Special } $\pm 20\%$	A-50849-1		
Capacitor—Ceramic 51 $\mu$ f { AC } $\pm 5\%$	A-50849-2		
Capacitor—Ceramic 75 $\mu$ f { Voltage } $\pm 5\%$	A-50849-3		
Capacitor—Ceramic 82 $\mu$ f { Ratings } $\pm 5\%$	A-50849-4		

THE FOLLOWING DC VOLTAGE MEASUREMENTS ARE TAKEN WITH A VTVM WITH AN INPUT RESISTANCE GREATER THAN 10 MEGOHMS. RECEIVE VOLTAGES ARE TAKEN AT MAXIMUM RF GAIN WITH NO SIGNAL INPUT. TRANSMIT VOLTAGES ARE TAKEN FULL POWER OUTPUT INTO A 50 OHM DUMMY LOAD.

Tube	Type	Function	Pin	Receive	Transmit
V-1 V-2	6GJ5 6GJ5	FINAL AMPLIFIER	1	0	+ 220 V
			2	- 45 to - 55 V ADJUSTABLE WITH BIAS CONTROL	
			3	0	+ .96 V
			4	V1 - 12.6 V2 - 6.3	AC OR DC DEPENDING ON SUPPLY
			5	V1 - 6.3 V2 - 0	
			6	- 45 to - 55 V ADJUSTABLE WITH BIAS CONTROL	
			7	0	+ 220
			8	0	0
			9	0	0
			CAP	+ 800	+ 700 DO NOT MEASURE ON TRANSMIT
V-3	12BY7	DRIVER	1	0	+ 3.5 V
			2	- 40	- 2 V
			3	0	0
			4	0	0
			5	12.6 AC OR DC DEPENDING ON SUPPLY	
			6	0	0
			7	+ 280	+ 280
			8	+ 220	+ 220
			9	0	0
V-4	12BE6	TRANSMIT MIXER	1	- 40	- 1.7
			2	0	0
			3	0	0
			4	12.6 AC OR DC DEPENDING ON SUPPLY	
			5	+ 280	+ 230
			6	+ 260	+ 70
			7	- 40	0
V-5	12AU6	VFO	1	- 1.4	- 1.4
			2	0	0
			3	0	0
			4	12.6 AC OR DC DEPENDING ON SUPPLY	
			5	+ 130	+ 130
			6	+ 140	+ 140
			7	+ .1	+ .1
V-6	12AT7	SPEECH AMPLIFIER AND "S" METER AMPLIFIER	1	+ 60	+ 60
			2	0	0
			3	+ 1V	+ 1V
			4	12.6 AC OR DC DEPENDING ON SUPPLY	
			5	12.6 AC OR DC DEPENDING ON SUPPLY	
			6	+ 220	- .8
			7	- .25	- .65
			8	+ 2.5	0
			9	0	0
V-7	6GH8 6AN8	MICROPHONE PRE-AMPLIFIER AND RELAY CONTROL	1	+ 90	+ 280
			2	- 1	- 32
			3	0	0
			4	0	0
			5	0	0
			6	0 ON CW OR TUNE FUNCTIONS + 95 ON SSB OR AM FUNCTIONS	
			7	+ 27	+ 16
			8	- .6	- .6
			9	0	0
V-8	12BA6	RF AMPLIFIER	1	- .2	- 110
			2	0	0
			3	0	0
			4	12.6 AC OR DC DEPENDING ON SUPPLY	
			5	+ 280	+ 280
			6	+ 100	- .9
			7	+ 2.5	+ .7
V-9	12BE6	RECEIVER MIXER	1	- .5	- 40
			2	0	0
			3	0	0
			4	12.6 AC OR DC DEPENDING ON SUPPLY	
			5	+ 220	+ 200
			6	+ 70	- .8
			7	0	0
V-10	12BA6	1ST IF AMPLIFIER	1	0	0
			2	0	0
			3	0	0
			4	12.6 AC OR DC DEPENDING ON SUPPLY	
			5	+ 210	+ 210
			6	+ 60	+ 60
			7	+ .6	+ .6

Tube	Type	Function	Pin	Receive	Transmit
V-11	12BA6	2ND IF AMPLIFIER	1	25	3.5
			2	0	0
			3	0	0
			4	12.6 AC OR DC DEPENDING ON SUPPLY	
			5	+ 210	+ 210
			6	+ 70	+ 70
			7	+ 2.2	+ 1
V-12	12BA6	CARRIER OSCILLATOR	1	- 21	22
			2	0	0
			3	0	0
			4	12.6 AC OR DC DEPENDING ON SUPPLY	
			5	+ 90	+ 100
			6	+ 122	+ 126
			7	0	0
V-13	12BA6	3RD IF AMPLIFIER	1	0	25
			2	0	0
			3	0	0
			4	12.6 AC OR DC DEPENDING ON SUPPLY	
			5	+ 210	- 8
			6	+ 75	- 8
			7	+ 1.5	0
V-14	12AX7	PRODUCT DETECTOR AM DETECTOR AUDIO AMPLIFIER	1	+ 90	+ 220
			2	- 4	- 22
			3	0	0
			4	0	0
			5	12.6 AC OR DC DEPENDING ON SUPPLY	
			6	+ 140	+ 220
			7	- 1.5	- 32
			8	+2.5 on SSB or CW Function 0 on AM Function	0
			9	*	*
V-15	6AQ5	AUDIO OUTPUT	1	*	*
			2	0	0
			3	0	0
			4	12.6 AC OR DC DEPENDING ON SUPPLY	
			5	+ 260	+ 270
			6	+ 220	+ 220
			7	+ .4	35
V-16	12AU7	1ST AND 2ND VOX AMPLIFIER	1	+ 60	+ 60
			2	0	0
			3	+ 2.2	+ 2.2
			4	0	0
			5	12.6 AC OR DC DEPENDING ON SUPPLY	
			6	+ 70	+ 70
			7	- 4	- 4
			8	0	0
			9	*	*
V-17	7360	BALANCED MODULATOR	1	0	+ 3
			2	0	+ 110 V
			3	- 40	0
			4	12.6 AC OR DC DEPENDING ON SUPPLY	
			5	0	0
			6	+ 200	+ 150
			7	+ 200	+ 150
			8	+20 to +30	0 ON TUNE FUNCTION +20 to +30
			9	+20 to +30	Depending On Carrier Balance +20 to +30
V-18	OA2	VOLTAGE REGULATOR	1	+ 150	+ 150
			2	0	0
			3	NO CONNECTION	
			4	*	*
			5	+ 150	+ 150
			6	NO CONNECTION	
			7	0	0

\* Pins so indicated make internal connections to the vacuum tube elements and will indicate voltages even though no external connection is made.

## ***NCX-3 SPECIFICATIONS***

Frequency Range: 3480 Kc to 4020 Kc, 6980 Kc to 7310 Kc, 13880 Kc to 14420 Kc. Types of Emission: SSB (LSB 80 and 40 meters, USB 20 meters), AM (SSB with carrier inserted), CW • R.F. Power Input: 200 watts SSB, 200 watts CW, 100 watts AM • R.F. Power Output: 120 watts SSB PEP, 120 watts CW, 30 watts AM • Output Impedance Matching Range: 40-60 ohms • SSB Generation: 5200 Kc crystal filter; bandwidth 2.5 Kc at 6 db • Frequency Stability: 400 cycles long-term after warm-up • Suppression: carrier —50 db; unwanted sideband —40 db • Operating Facilities: all modes — full AGC and S-Meter on receive; SSB — VOX or PTT transmit, product detector on receive; AM — VOX or PTT transmit, triode detector on receive; CW — grid block break-in transmit, product detector on receive • Audio Input: High impedance, low level • Controls: Front panel — Main Tuning, Band Selector, Audio Gain, R.F. Gain, Microphone Gain — Calibrator on-off, Mode (off, SSB, AM, CW, tune), Carrier Balance, Driver Tune, PA Tune, PA Load, Mic. input, Phone jack; Rear panel — Vox Sensitivity, Calibrator, Vox Delay, Bias Adjust, VOX/PTT Switch, Key, Ext. relay • Metering: PA cathode current on transmit; S-Meter on receive • Receiver Sensitivity: 1.0 uv for 10 db S/N ratio • Receiver Selectivity: 2.5 Kc at 6 db • Receiver Audio Output: Better than 2 Watts; 3.2 ohms • Size: 6-1/16" H, 13 5/8" W, 11 5/8" D • Shipping Weight: 25 pounds. Power Requirements: 700 V.D.C. @ 300 ma., 280 V.D.C. @ 125 ma., —80 V.D.C. @ 10 ma., 12.6 V. @ 5A. • Tube Complement: 18 tubes, 6 diodes, 26 Functions; parallel 6GJ5's in final amplifier. Mechanical: 1/8" solid extruded aluminum front panel; perforated steel enclosure; cadmium plated steel chassis; anodized brushed aluminum gimbaled mobile mounting bracket • Main Tuning Ratio: 45:1, employing planetary and split gear drive • Finish: Front panel — Hydro-etch off-white matte with brushed aluminum trim; Knobs — Mil-Spec, matte black; Enclosure — gray-blue wrinkle enamel.

*Tuned to Tomorrow*

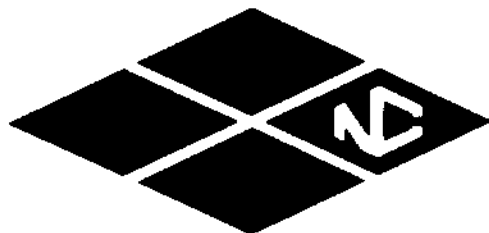

**NATIONAL RADIO CO.**  
37 WASHINGTON STREET, MELROSE, MASSACHUSETTS  
**NCX-3 TRANSCEIVER**



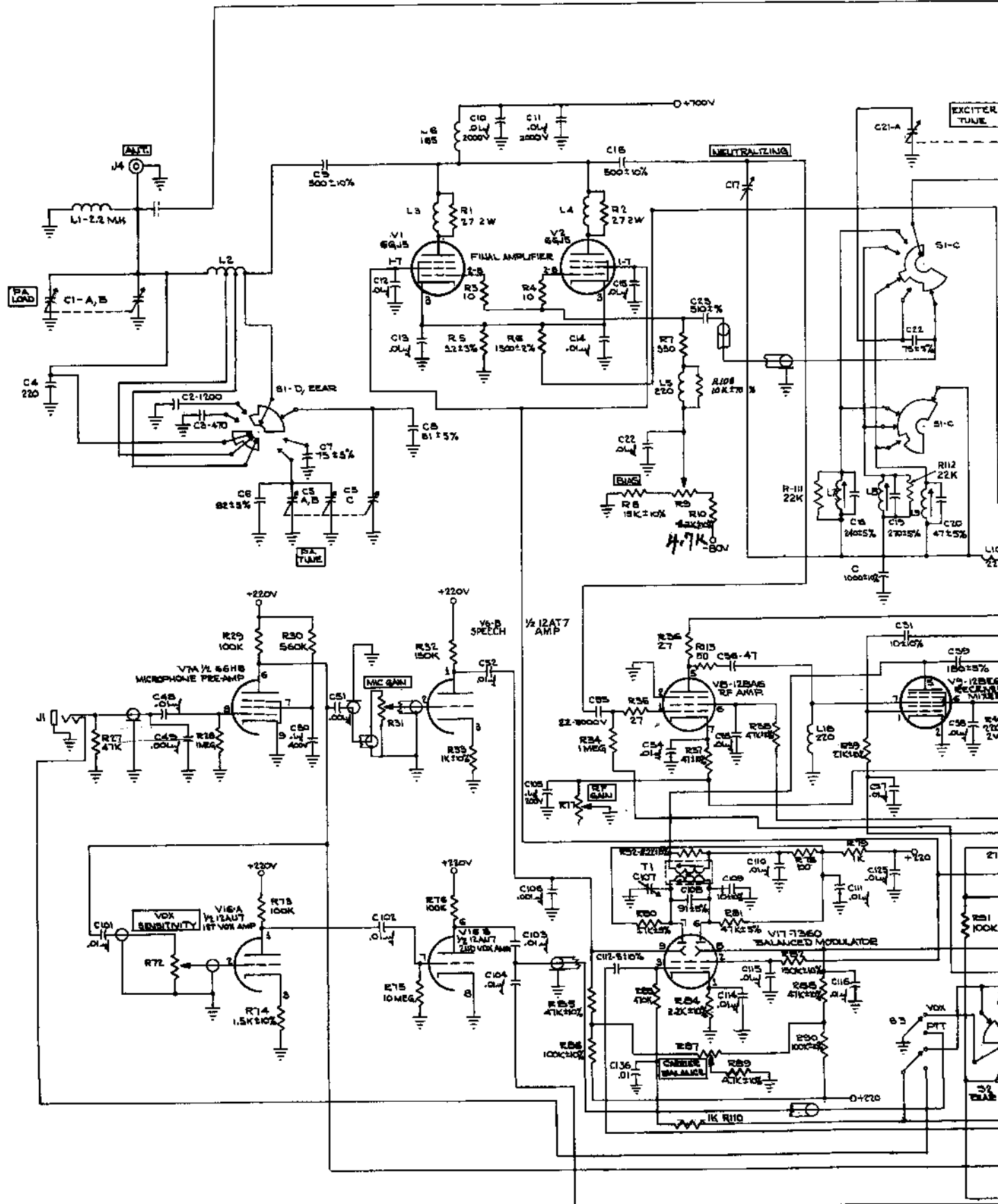

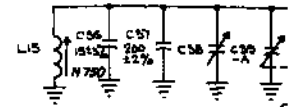

EXCITER TUNE

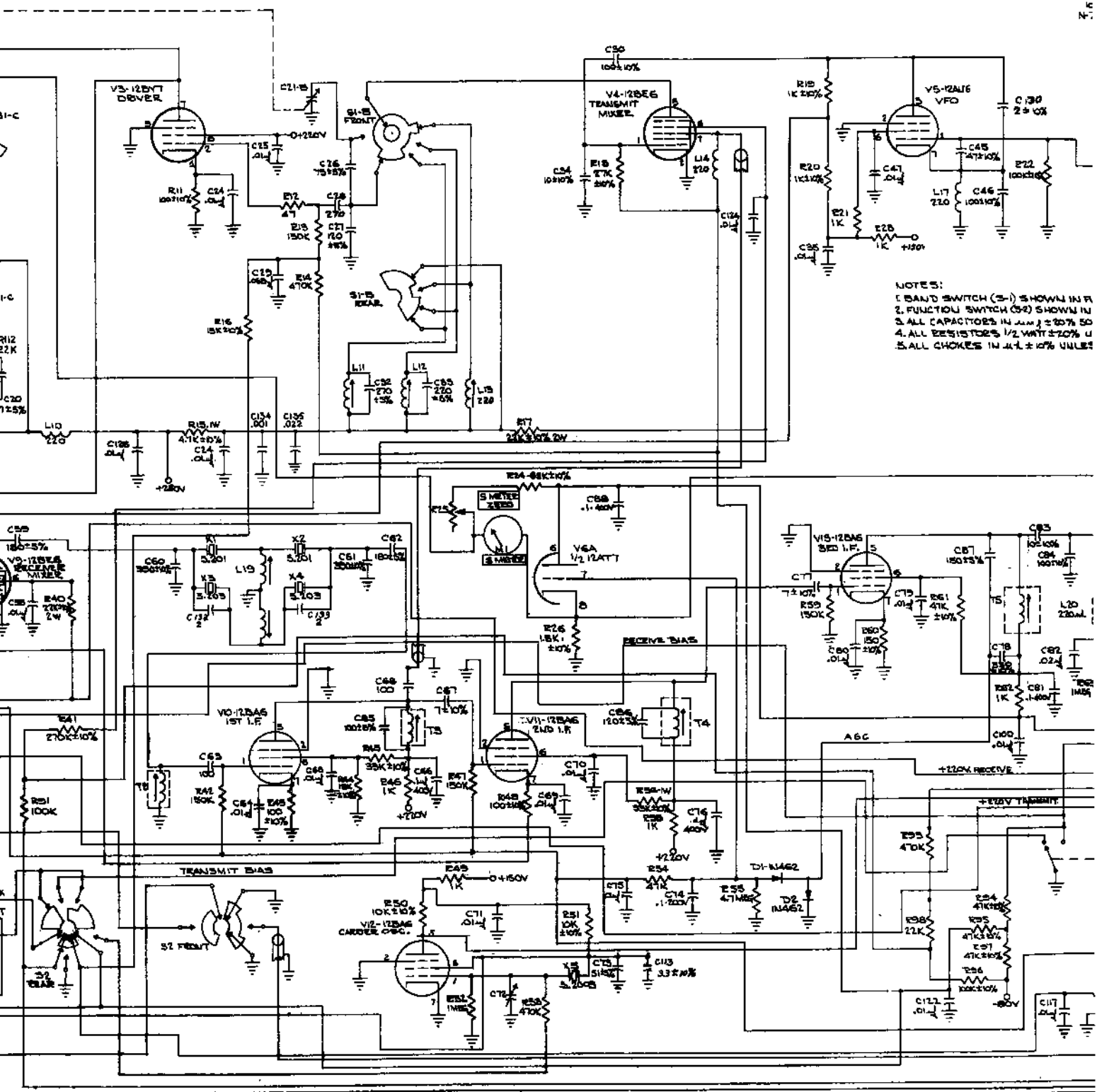

NOTES:  
 1. BAND SWITCH (S-1) SHOWN IN P  
 2. FUNCTION SWITCH (S-2) SHOWN IN  
 3. ALL CAPACITORS IN μM ± 20% 50  
 4. ALL RESISTORS 1/2 WATT ± 20% U  
 5. ALL CHOSES IN μH ± 10% UNLESS

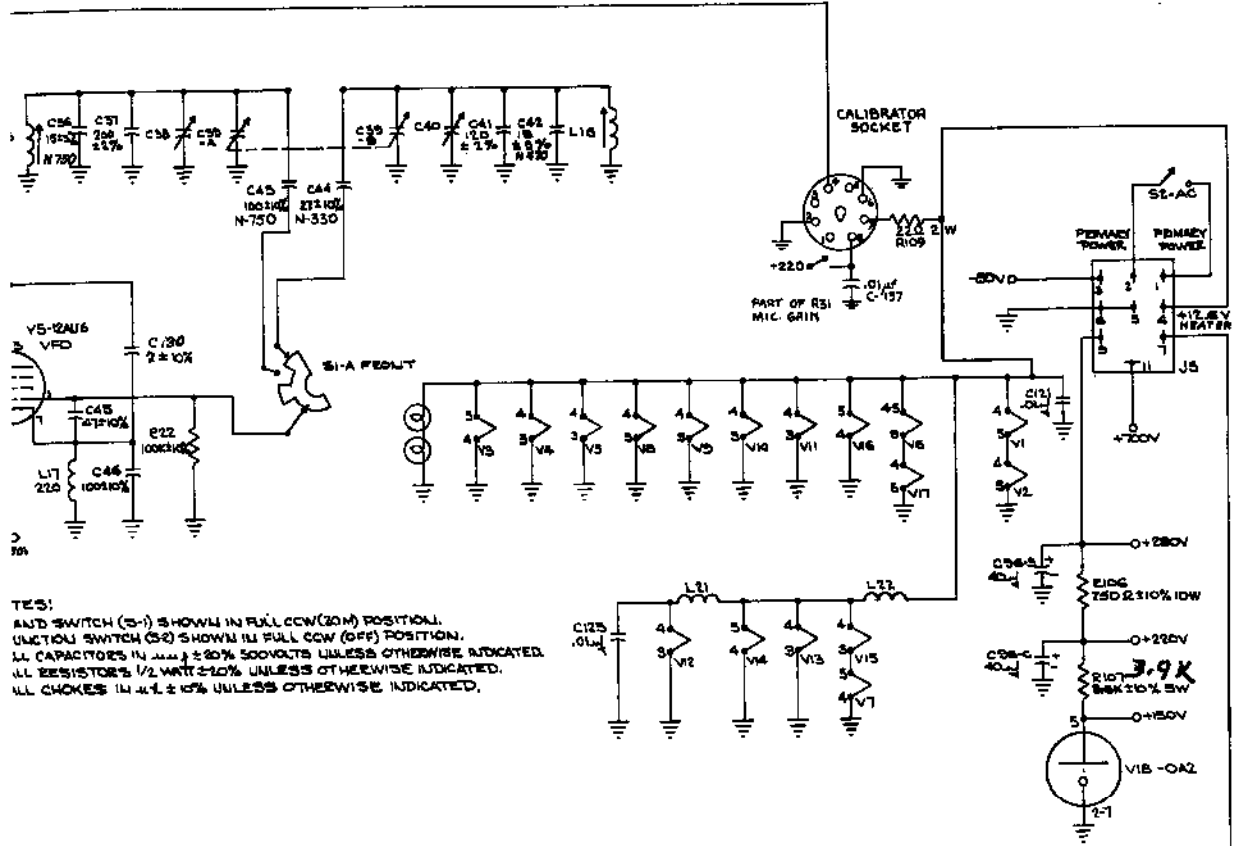

TESTS:  
 AND SWITCH (S-1) SHOWN IN FULL CCW (20M) POSITION.  
 FUNCTION SWITCH (S-2) SHOWN IN FULL CCW (OFF) POSITION.  
 ALL CAPACITORS IN  $\mu\text{F}$   $\pm 20\%$  500VOLTS UNLESS OTHERWISE INDICATED.  
 ALL RESISTORS 1/2 WATT  $\pm 10\%$  UNLESS OTHERWISE INDICATED.  
 ALL CHOKES IN  $\mu\text{H}$   $\pm 10\%$  UNLESS OTHERWISE INDICATED.

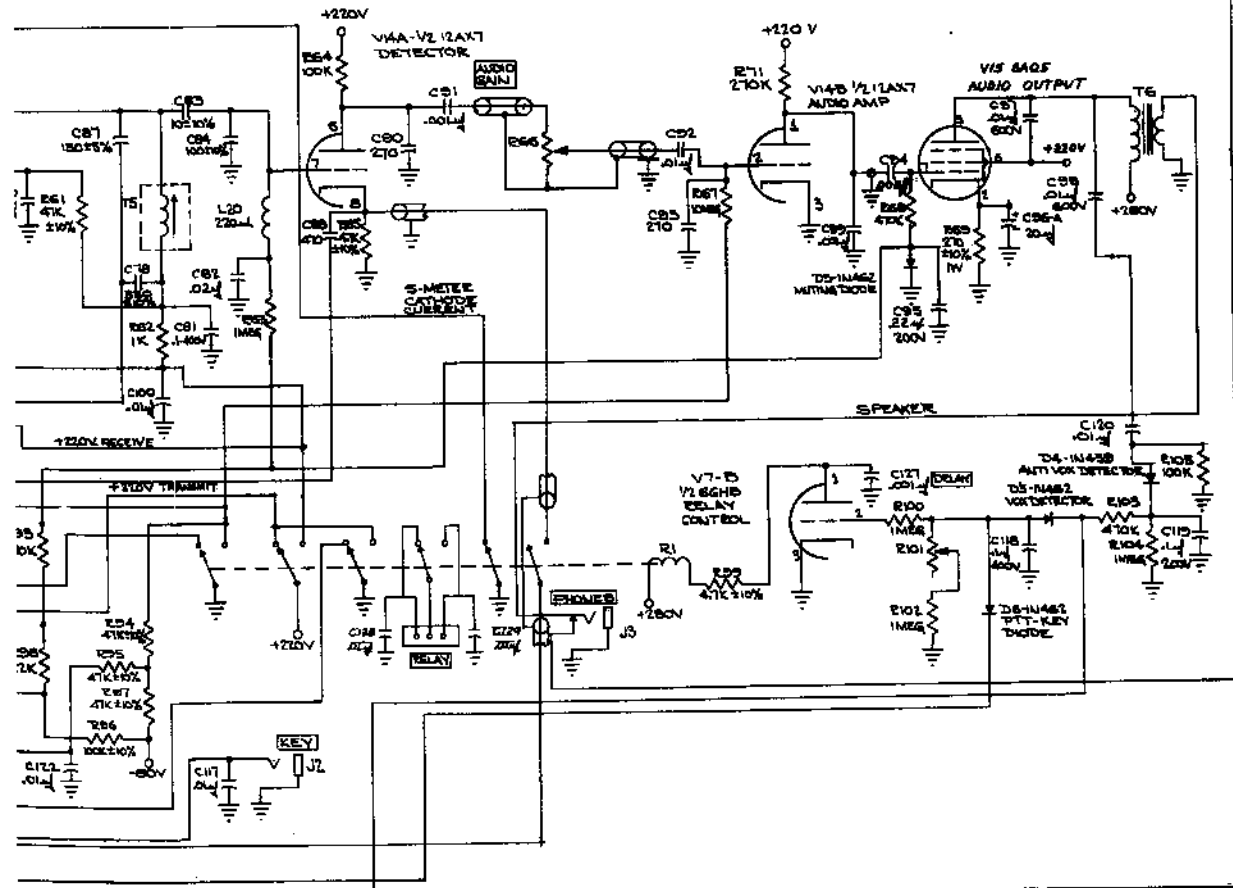

# ACCESSORY POWER SUPPLIES

## *Instruction Manual*

MODEL NCX-A  
MODEL NCX-D

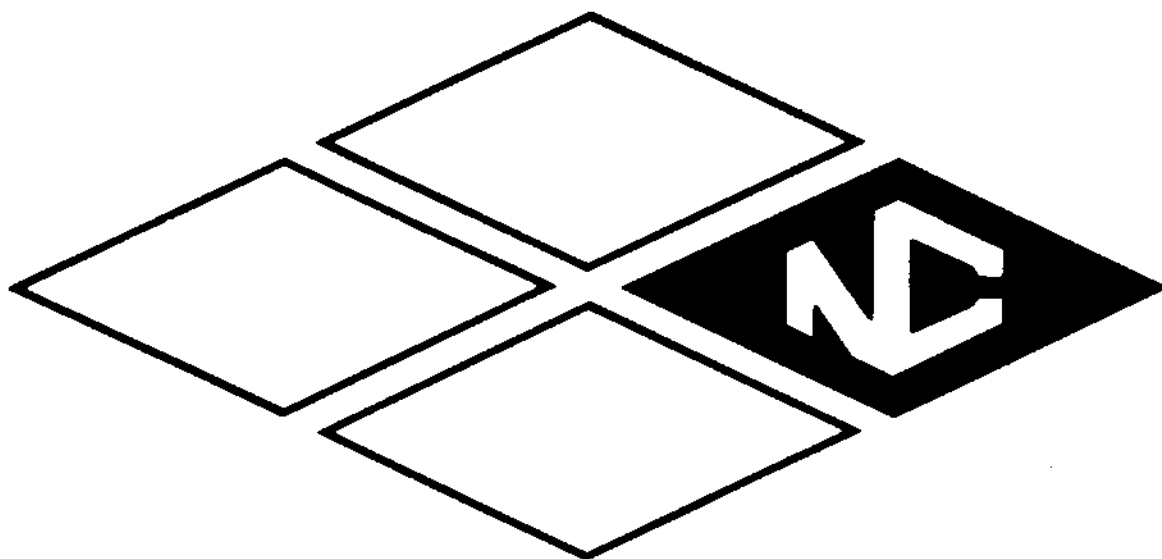

NATIONAL RADIO COMPANY

## NCX-A POWER SUPPLY

The NCX-A Power Supply is a conservatively rated supply capable of providing all necessary power to operate the National NCX-3 transceiver or other similar equipment. The supply is housed in a gray-blue perforated cabinet with a front panel matching the styling of the NCX-3. Included with the supply is a 4" x 6" oval speaker which is mounted behind the front panel. The supply is equipped with a power plug and 3' cable so that it may be connected directly to the NCX-3 transceiver, with no other power or speaker connections required.

Referring to the schematic diagram, 117 VAC is supplied from the line cord through the power supply protection fuse. A pair of switching leads is connected to the NCX-3 through Pins 1 and 2 of the cable and plug. A bridge rectifier using diodes D1, D2, D3 and D4, swinging choke L1 and the filter capacitors C1 and C2 provide 700 volts dc to the final amplifier tubes in the NCX-3. This high-voltage supply is capable of supplying 700 volts at 50 to approximately 300 ma. at better than 2% regulation from minimum to maximum load. In order to provide maximum efficiency in the NCX-A supply, the low-voltage dc is taken from the center tap of the high-voltage winding. The low-voltage dc from the center

tap is filtered by choke L2 and capacitor C3. It is dropped and further filtered by resistor R5 and R6 and a filter capacitor inside the NCX-3 transceiver. This provides 280 volts at 125 ma. at terminal 9 of plug P1. Resistor R8 is a 30,000 ohm bleeder resistor to prevent shock hazard.

The output of the bias winding of T1 is rectified by diodes D5 and D6. This rectified output is filtered by the combination of resistor R7 and capacitor C4 and provides 80 volts at approximately 10 ma. for bias purposes to terminal 3 of the power plug P1.

### NCX-A SUPPLY RATINGS

#### INPUT:

117 V AC  $\pm$  10%, 50-60 cycles/second  
1.4 Amperes, 140 Watts receive  
3.7 Amperes, 365 Watts CW transmit

#### OUTPUT:

High Voltage 700 VDC at 50 to 300 ma.  
Low Voltage 280 VDC at 125 ma.  
Bias Voltage 80 VDC at 10 ma.

#### DIMENSIONS

8 $\frac{1}{2}$ " wide x 6 $\frac{1}{8}$ " high x 12" deep on 1 $\frac{1}{2}$ " feet.

#### WEIGHT

24 $\frac{1}{2}$  pounds

## NCX-D POWER SUPPLY

The NCX-D Power Supply is a transistorized self-oscillating DC to DC converter employing automatic reverse polarity protection and automatic short-circuit protection. The NCX-D supplies 700 vdc, 280 vdc, and 80 vdc voltages from a 12 vdc positive or negative ground power source.

Referring to the schematic diagram, Q1 and Q2 are 2N1518 transistors operating in a self-oscillating circuit to supply 12 VAC power to the primary of the transformer. The power supply oscillator runs at a frequency of 200 cycles per second instead of the usual 100 cycles thus minimizing the annoying whine often associated with this type of power supply. Power is supplied to this transistor-oscillator circuit through contacts of the relay K1. The coil of the relay K1 is supplied with power when +12 v is applied through diode D1 in series with the relay coil. If the supply voltage is reverse connected to the NCX-D, diode D1 will not conduct. Thus, relay K1 cannot close and the power supply is protected against accidental reverse polarity.

The high voltage secondary supplies power to a voltage doubling circuit consisting of diodes D2, D3, D9 and D10 and filter capacitors C2 and C3. This circuit provides 700 vdc at 300 ma. to terminal 9 of the terminal board. Resistor R3 is a bleeder resistor across capacitors C2 and C3.

The low voltage winding of the transformer supplies power to a bridge rectifier consisting of diodes D4, D5, D6 and D7. The output of this bridge rectifier, filtered by the combination of L1 and C1 sup-

plies 280 vdc at 125 ma. to terminal 8 of the terminal board. Power supplied by the bias winding is rectified by diode D8 and filtered by capacitor C5 to supply 80 vdc at approximately 10 ma. to terminal 7 of the power supply terminal board. Terminal board connection 3 is a common lead which provides a ground return for each of the above-mentioned supply voltages.

### INSTALLATION INSTRUCTIONS

The NCX-D power supply is furnished with four 10/32 threaded mounting holes on each of two sides of the power supply. The supply is rated for full power output at a maximum ambient temperature of 140° F. (60° C.). The NCX-D may be mounted in many locations in the automobile, such as in the trunk, under the seat, against the firewall or under the dash. An extremely convenient location for the NCX-D is atop or alongside the steering column, secured by means of radiator clamps around the column and attached to the 10/32 mounting holes in the supply.

Consideration should be given to the distance of the NCX-D supply from the battery terminals. Table 1 lists various recommended wire sizes which may be used to supply 12 v power to the NCX-D supply. This table also gives the voltage drop-per-foot for both cables when the NCX-D supply is running at full power capacity. The power supply may be located some distance from the transmitter or transceiver since the remote switching leads do not carry full primary dc power to the supply.

Since each installation varies depending upon the automobile, the location of the supply, and the operator's preferences, it is not practical to supply a wired cable to connect the NCX-D supply to its transmitter or transceiver load. Figure 3 shows the connections necessary to supply power to the NCX-D supply, and from the NCX-D supply to the NCX-3 transceiver. A connection from terminal 6 of the supply to pin 4 of the power plug should only be used if the automobile battery has a negative ground. If your automotive system has a positive ground, a lead from pin 4 of the power plug should be run to pin 4 of the NCX-D supply. This is shown in the alternate dotted line connection for positive ground power sources, as well as the necessary jumper from the grounded input terminal to common ground on the barrier strip.

## NCX-D

### DIMENSIONS

7 $\frac{3}{4}$ " wide x 4 $\frac{1}{4}$ " high x 5 $\frac{3}{8}$ " deep

### WEIGHT

5 pounds

## NCX-D SUPPLY RATINGS

### INPUT:

12.0  $\pm$  volts  
at 5 amperes - receive  
at 28 amperes - CW transmit

### OUTPUT:

High Voltage - 700 vdc at 50 to 300 ma.  
Low Voltage - 280 vdc at 125 ma.  
Bias Voltage - -80 vdc at 10 ma.

## FUSES

A momentary short circuit of the 700 volt output will cause the NCX-D power supply to stop oscillating. No harm will be done to the unit. Normal operation will occur when the short circuit is removed. In addition, the 280 volt output and the -80 volt output circuits are fused by #43 panel lamps. Momentary short circuit of either of these outputs will result in failure of L1 or L2. These lamps may be replaced by removing the top cover of the NCX-D supply. The primary power input of the NCX-D supply is protected by a slow blow primary power fuse, type MDX-40. Do not replace with other than the recommended type.

TABLE 1

WIRE SIZE AWG	VOLTAGE DROP/FOOT (2 CABLES)
4	0.019 V
6	0.030 V
8	0.048 V
10	0.076 V
12	0.121 V

ALL READILY AVAILABLE RESISTORS AND CAPACITORS ARE OMITTED FROM THE FOLLOWING PARTS LIST, BUT ARE COMPLETELY IDENTIFIED ON THE SCHEMATIC.

## PARTS LIST

### NCX-A POWER SUPPLY

DESCRIPTION	PART NUMBER
Plug, Jones, Female	A50R28
Strain Relief Bushing	A50R92-1
Capacitor, Electrolytic, 40 $\mu$ f 450 VDCW	C19458-7
Capacitor, Electrolytic, 40 $\mu$ f 150 VDCW Tubular	C19411-3
Capacitor, Electrolytic, 80 $\mu$ f 450 VDCW Tubular	C19411-4
Fuse Holder	A50R62
Transformer, Power	C50R71
Choke, Swinging	B50R63
Choke, Filter	B50R64
Rectifier, Silicon, 1600 PIV Similar to IN2359	A50R76
Rectifier, Silicon, 500 PIV Similar to IN534	A50R74
Resistor, 7,500 ohms, 5 w $\pm$ 10%	R17436-13
Resistor, 30,000 ohms, 5 w $\pm$ 10%	R17436-14
Resistor, 330 ohms, 10 w $\pm$ 10%	R17436-1
Line Cord	B22132-6
Cable, 8 Conductor	B50R77
Front Panel, Complete	D50R75-2
Speaker, 6" oval	C50R82
Cabinet, Complete	D50R70-8
Foot, Extension	A50R50
Foot, Rubber	A50R51

### NCX-D POWER SUPPLY

DESCRIPTION	PART NUMBER
2N554 Transistor	
2N1518 Transistor	
Transformer, Transistor Power Rectifier, Silicon, 400 PIV Similar to IN1490	B50R12
Relay, 12 VDC	A50R16
Fuse, 40 Ampere	A50R17
Fuse Holder	A50R18
Resistor, 3 ohm, 10 watt	A51093
Resistor, 100 ohm, 5 watt	A51092
Terminal, 12 VDC Red	A50R21-1
Terminal, 12 VDC Black	A50R21-2
Terminal Strip, Barrier	A50R06
Capacitor, Electrolytic, 40 $\mu$ f 450 VDC Tubular	B50R15-1
Capacitor, Electrolytic, 20 $\mu$ f 350 VDC Tubular	B50R15-2
Capacitor, Electrolytic, 10 $\mu$ f 150 VDC Tubular	B50R15-3
Capacitor, Electrolytic, 50 $\mu$ f 25 VDC	B50R15-4
Heat Sink, Transistor	A50R22
Case, NCX-D	B50R23
Cover, NCX-D Supply	B50R24
Terminal Board, NCX-D Supply	B50R25

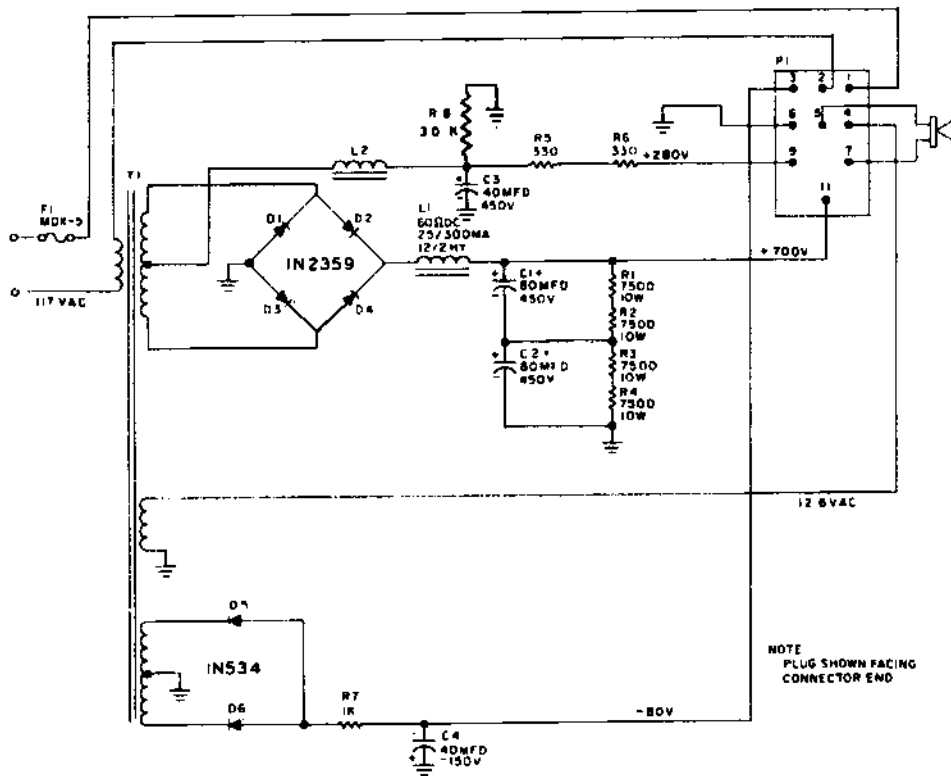

Figure 1. NCX-A Power Supply Schematic

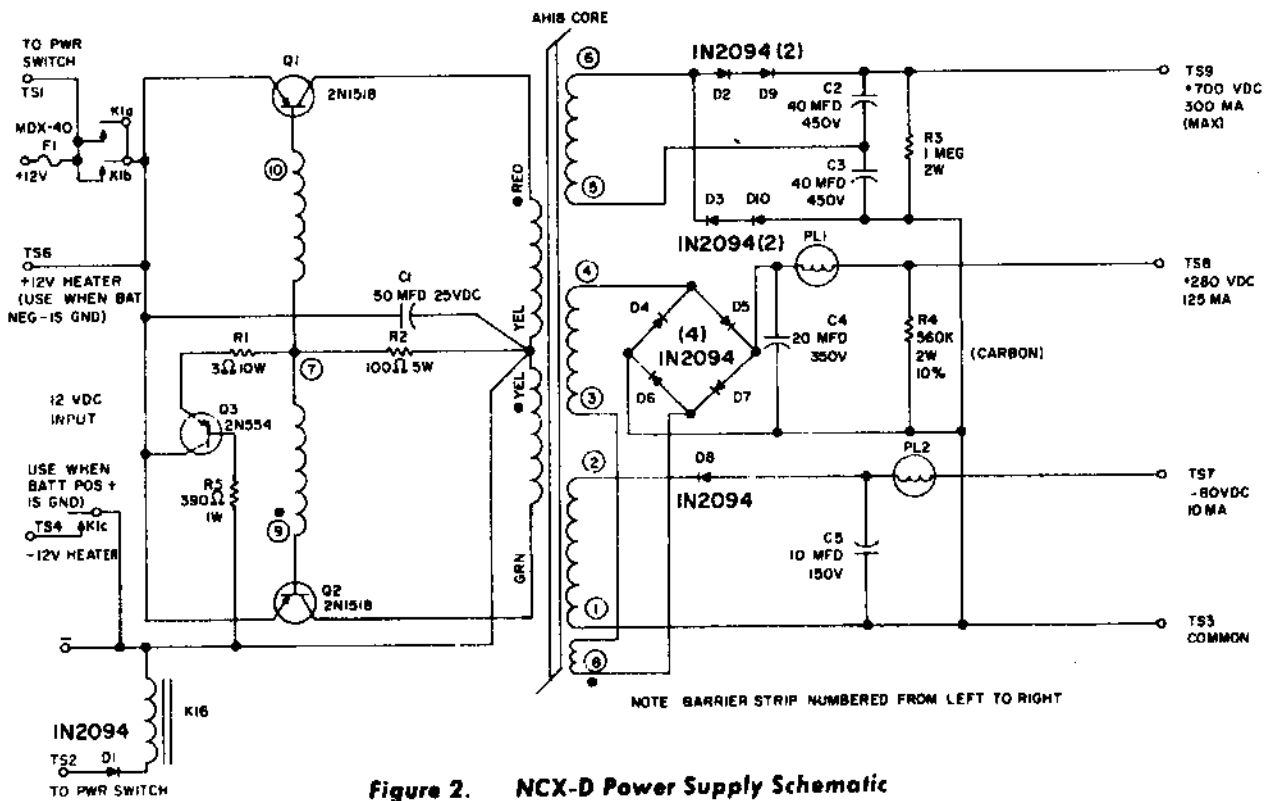

Figure 2. NCX-D Power Supply Schematic

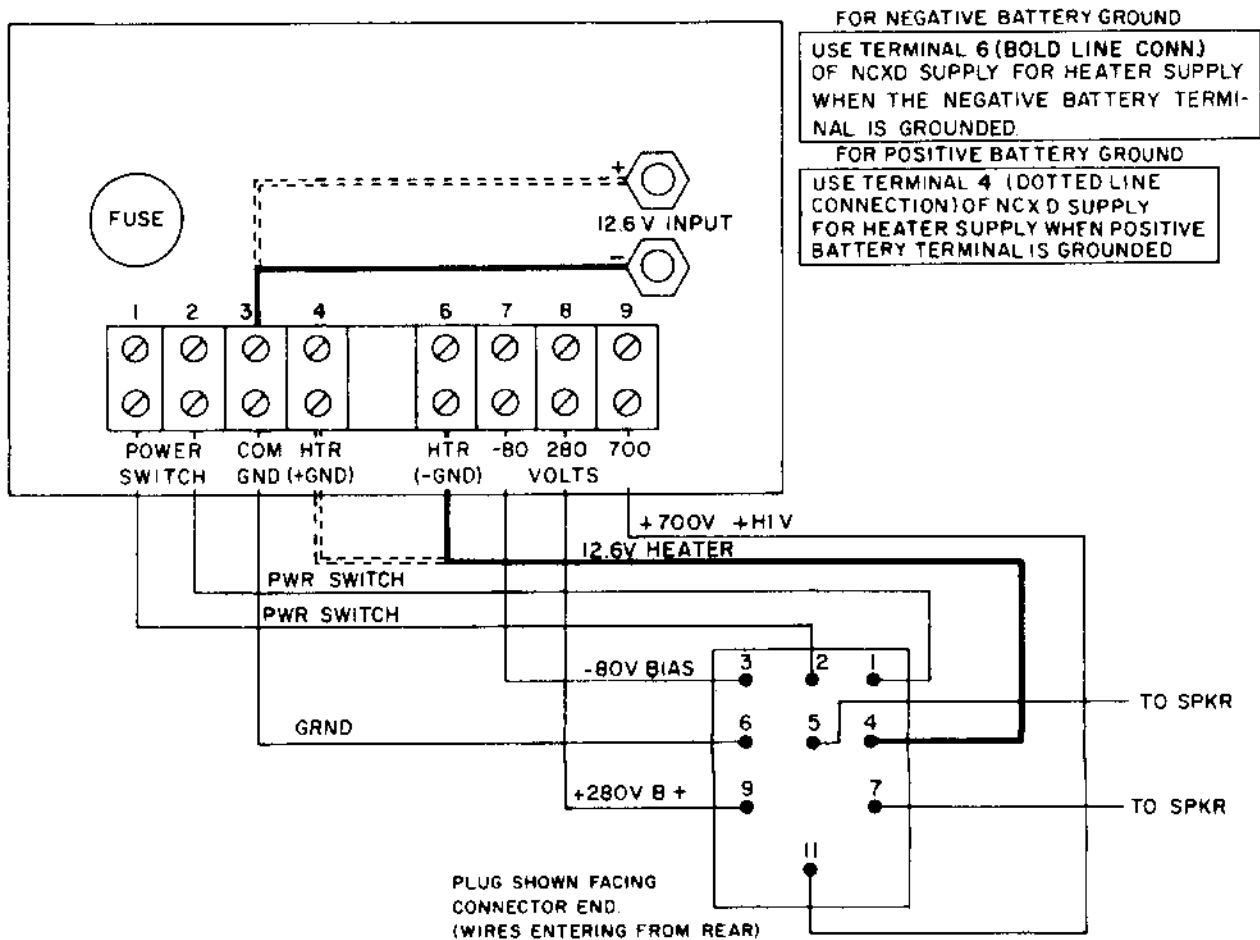

Figure 3. NCX-D Wiring Connections





## CUSTOMER SERVICE BULLETIN

January 2, 1964  
Sales Bulletin: #CIB 63-8

Enclosed you will find two resistors to be installed in your NCX-3 per the instructions provided. Total time to make the mod should be no longer than five minutes.

As you may be aware, the NCX-3 is susceptible to an "FM" effect on speech peaks, resulting from overmodulation, improper loading, insufficient low B+, etc. Since they may be closely controlled by the operator, most, if not all, of these problems are absent during fixed station operation. However, mobile operation by its nature is such that it is often difficult to keep from hitting the rig too hard or to be certain that the transceiver is tuned right on the button. Accordingly, one or a combination of the above can result in a signal that "FM's".

We strongly encourage you to make this change at your earliest convenience, as it results in quite a dramatic improvement in the operating characteristics of the NCX-3. The result of this modification is the complete elimination of any "FM" tendency, even under exaggerated mistuning or too-high microphone gain. In fact, tests we've run on many units at the factory indicate that it is impossible to make the NCX-3 "FM" with the mod installed, unless voltage is so low that the VR tube will not ignite (a condition which should never exist). There are a couple of desirable side effects as well--power output is increased, and overall linearity is improved. We must say that we've never had anything but compliments in either of these areas, but we make the point anyway. We suggest that you make the mod even if you don't operate mobile, if for no other reason than to bring your unit up to date with the latest NCX-3's being shipped.

### Modification Instructions

Remove your NCX-3 from its case and turn upside down with the front panel facing you. You will note that at the rear of the chassis just in front of the Jones power plug is the 40-40-20 MFD filter capacitor, C96, and the voltage regulator tube socket, V18-OA2. The resistor, R107 (2.5K wire wound), should be removed from the circuit. This resistor is connected from the 40MFD section of the capacitor, C96, (the section where there is a junction of two red leads and which is nearest the PA load capacitor) to Pin 5 of the VR tube OA2.

Now from Pin 5 on the VR tube socket solder the new 3.9K resistor. The other end of this resistor should be soldered to the terminal on the barrier strip nearest the VR tube socket where there is also a purple lead and one end of a 750 ohm resistor. (These parts should remain soldered to this terminal). Dress the leads so they are as short as possible.

The next resistor to be replaced is R10 (8.2K gray, red, red, silver). This resistor is connected between Pin 3 of the Jones power plug and one leg of the bias control, R9. This resistor should be removed from the circuit, and the spaghetti tubing removed from the resistor.

The 4.7K resistor supplied should be cut so that about 3/4" of lead remains on either

side. Place the spaghetti tubing on the leg of the resistor that will be soldered to the bias control. The new 4.7K resistor should be soldered to the same points as was the 8.2K resistor which was removed. The resistor should also be dressed in the same manner.

A double check should now be made for possible errors or short circuits. Replace the transceiver in the cabinet, and secure all the mounting screws. This will complete the modification of your NCX-3.

73,

  
Harvey Wiltmore, K1GKO  
Customer Service Manager

HW/tlw



## **CUSTOMER SERVICE BULLETIN**

May 31, 1966

NCX-3  
CSB 66-2

National Radio Customer Service Bulletins are provided free to all registered owners of our equipment. Information contained herein is gathered from our factory and field service organizations as well as from National owners.

We do not recommend the "automatic" incorporation of modifications except when the trouble description is identical to your problem, or when suggested for preventive maintenance.

### CHIRP ON CW

It has been brought to our attention that some NCX-3's exhibit chirp on CW. This is due to an RF voltage being fed back to the voltage regulator tube, V-18.

The above condition can be eliminated as follows:

Remove the red wire from Pin 1 of V-18 and reconnect to Pin 6. Add a 2.5mh 50ma RF choke between Pins 1 and 6. Add a .01 uf discap from Pin 6 to ground. Solder all connections.

### IMPROVED NEUTRALIZATION AT 3.5 Mc

a.) Place a solder lug under the holding screw of C-17, nearest the driver coils. Remove the ground end of C-138 from V-2 ground ring and reconnect to the new lug. Dress this capacitor flat against the chassis.

b.) Redress R-5 flat against the chassis so that it does not "look" into the plate circuit through the ventilation holes. It may be necessary to splice a wire to R-5 so that it lies flat.

c.) Move C-23 from top of terminal strip down into the rivet holes and place close against sub-chassis. Place coax grid drive lead in lower hole also, and tuck under cable harness.

(over)

NCX-3 (cont.)

d.) The correct setting of C-17 must be determined at 14.2 Mc. It should now be possible to get full output, or very close to it, at the dip at 3.5 Mc.

IMPROVED RECEIVER SENSITIVITY  
AND GRID DRIVE

Remove R-44 at the screen grid of V-10. Do not replace.

IMPROVED TRACKING OF 80 METER  
GRID DRIVE

Change C-18 from 240pf to 220pf 5%. Repeak 80 meter driver coil.

IMPROVED RECEIVING AUDIO QUALITY  
ON SSB

Change C-82 from .01 to .02uf.

INCREASED DRIVE AND RELIABILITY

We have found that changing the driver tube from 12BY7 to 6GK6 results in improved reliability and greater drive. The following changes are necessary in order to substitute the 6GK6:

- a.) Change R-11 to 100 ohms 1 watt.
- b.) Change R-13 to 100K ohms 1/2 watt.
- c.) Change V-4 to a 6BE6.
- d.) Remove the ground from Pin 3 of V-4.
- e.) Locate the brown wire going from Pin 4 of V-4 to Pin 5 of V-3. Remove from Pin 4 of V-4 and reconnect to Pin 3 of V-4. Connect a 12 ohm 10 watt resistor from Pin 4 of V-4 to Pin 5 of V-3.

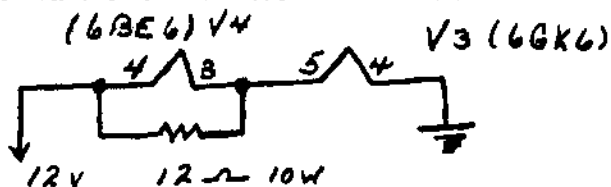

- f.) It will be necessary to repeak all driver and mixer coils.

(over)

NCX-3 (cont.)

### INCREASED PERFORMANCE

NCX-A supplies with serial numbers beginning with 44, 49, 57, 63, 69, or 72 may be modified for increased output.

The modification may be easily made by connecting a 660 ohm 10 watt resistor in parallel with the two 330 ohm 10 watt resistors R-5 and R-6 in the NCX-A supply. Designate the new resistor R-9.

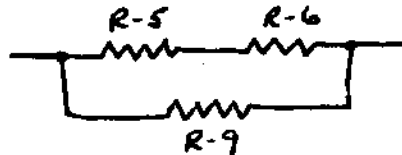

With this modification, the NCX-3 and the NCX-5 may be used with the same supply.

NCX-A supplies with serial numbers beginning 73 or higher have this resistor added at the Factory.

Service Department  
NATIONAL RADIO COMPANY

Technical Services Section

CWH:vfl

Distribution: All NCX-3 Owners  
List "L"  
List "F"

  
C. W. Huether KIUHY/K2QJM  
Service Manager

# NATIONAL RADIO COMPANY, INC.

A WHOLLY OWNED SUBSIDIARY OF NATIONAL CO., INC.



TEL. NORMANDY 5-4800  
CABLE ADDRESS "NATCO" BOSTON

37 WASHINGTON STREET  
MELROSE 76. MASS.

ESTABLISHED 1914

Dear O. M. :

We'd like to thank you for purchasing the NCX-3 transceiver, and at the same time provide you with a few hints and kinks which will help you to get even more enjoyment out of your new rig:

1. First of all, please mail your warranty card immediately, since as soon as it is received you will be placed on our NCX-3 customer service list to keep you immediately informed of forthcoming accessories, modifications or improvements, service notes etc.
2. Choice of microphone is important, since the NCX-3 is designed to provide the smoothest, cleanest audio possible. All necessary filtering and restriction of audio bandwidth is done in the NCX-3, and a so-called "restricted" or "communications quality" microphone will undo this design feature. Avoid ceramic or crystal microphones designed for Citizens Band use, since these mikes are usually designed to sell for a price -- and sound like it. Use the best microphone you can afford -- preferably a flat, wide range dynamic. We've found the Electro-Voice 664 and Shure 545 to be extremely good for fixed station use, although relatively expensive, and the Shure 10-4 dynamic and the new EV 600E are excellent for mobile application.
3. PA screen current is one of the best indicators of proper operation of the NCX-3, and since there is no separate screen meter in the NCX-3, an excellent substitute is the VR tube at the rear of the chassis. Should the final amplifier be operating improperly, excessive screen current will be drawn by the 6GJ5's which will cause sufficient voltage drop in the +280V bus to extinguish the VR tube (and simultaneously remove all oscillator regulation). The VR tube should stay lit with full carrier inserted during tune-up, and should not extinguish on SSB voice peaks. Typical reasons for VR tube trouble are insufficient loading, excessive microphone gain, low primary voltage to the power supply (low line voltage with the NCX-A, low battery voltage under idling or engine-off conditions with the NCX-D), or use of an improper power supply. It's always a good idea to glance at the VR tube after loading up on a new band to make certain everything is O. K. Caution: Do not attempt to transmit with the NCX-3 if the VR tube indicates a malfunction, since the result will be distortion, frequency shift, non-linearity etc. A quick check of the above trouble areas will show where the difficulty lies.

Again, thank you for buying National, and we will welcome your comments on your new NCX-3.

73,



Mike Ferber, W1GKX  
Equipment Sales Manager

MF:chc



*tuned to tomorrow*