



**INSTRUCTION MANUAL**

---

**T-2002**

---

# FEATURES

- **Built-in 800 Channels (5kHz steps):**  
You can both transmit and receive on the whole 2m band from 144 to 147.995MHz on each 5kHz step. The phase locked loop synthesizer, specially developed and designed is utilized in this set.
- **Digital Frequency Display with Large LEDs:**  
6 large LEDs for frequency display give the prompt and accurate readout of the frequency.
- **One Unit, One Function System:**  
Each unit has only one function so that the easier maintenance may be done. "A special RF power module" is used for the TX-POWER unit.
- **Improved Cross Modulation Characteristics:**  
The 4-stage helical resonator in the RF section, and the dual gate MOS FET in the mixer give satisfactory cross modulation characteristics.
- **A Built-in Protective Circuit:**  
"APC" protective circuit is incorporated into the set in order to protect final stage transistor from the breakdown.
- **Connector for the Phone Patch:**  
The set is provided with the accessory terminals for the phone patch.
- **Repeater Operation:**  
The transmission frequency can be shifted to  $\pm 600\text{kHz}$  and  $\pm 1\text{MHz}$ , providing an enjoyable QSO by using the repeater.
- **Two External Speaker Jacks:**  
The set is equipped with the one jack for using external speaker only, and the other jack for simultaneously using both the built-in speaker and the external speaker.

## PRECAUTIONS

Be sure to observe the following instructions in operation.

- Do not transmit without an antenna.
- Continuous transmission (for more than 30 minutes) should be avoided as much as possible.
- Use DC 13.8V as the power supply.
- Do not open the set. All the cores and trimmers have already been adjusted, so no further adjustment is required.
- In vehicle operation, avoid installing the set at the hot air exhaust outlet. When the set is too hot, wait for a second until cooling off a bit.

## ACCESSORIES

The equipment has the following accessories. Please check that you have all of them.

Warranty card . . . . .	1
Instruction manual . . . . .	1
Spare fuse (10A) . . . . .	1
DC power cord (with connector and fuse) . . .	1
Bracket . . . . .	1
Microphone . . . . .	1
EXT SP plug . . . . .	1
Stand . . . . .	1
Washer . . . . .	1
Tapping screw . . . . .	2
Solderless terminal . . . . .	1
24P plug . . . . .	1

# NAMES OF PARTS AND DESCRIPTION

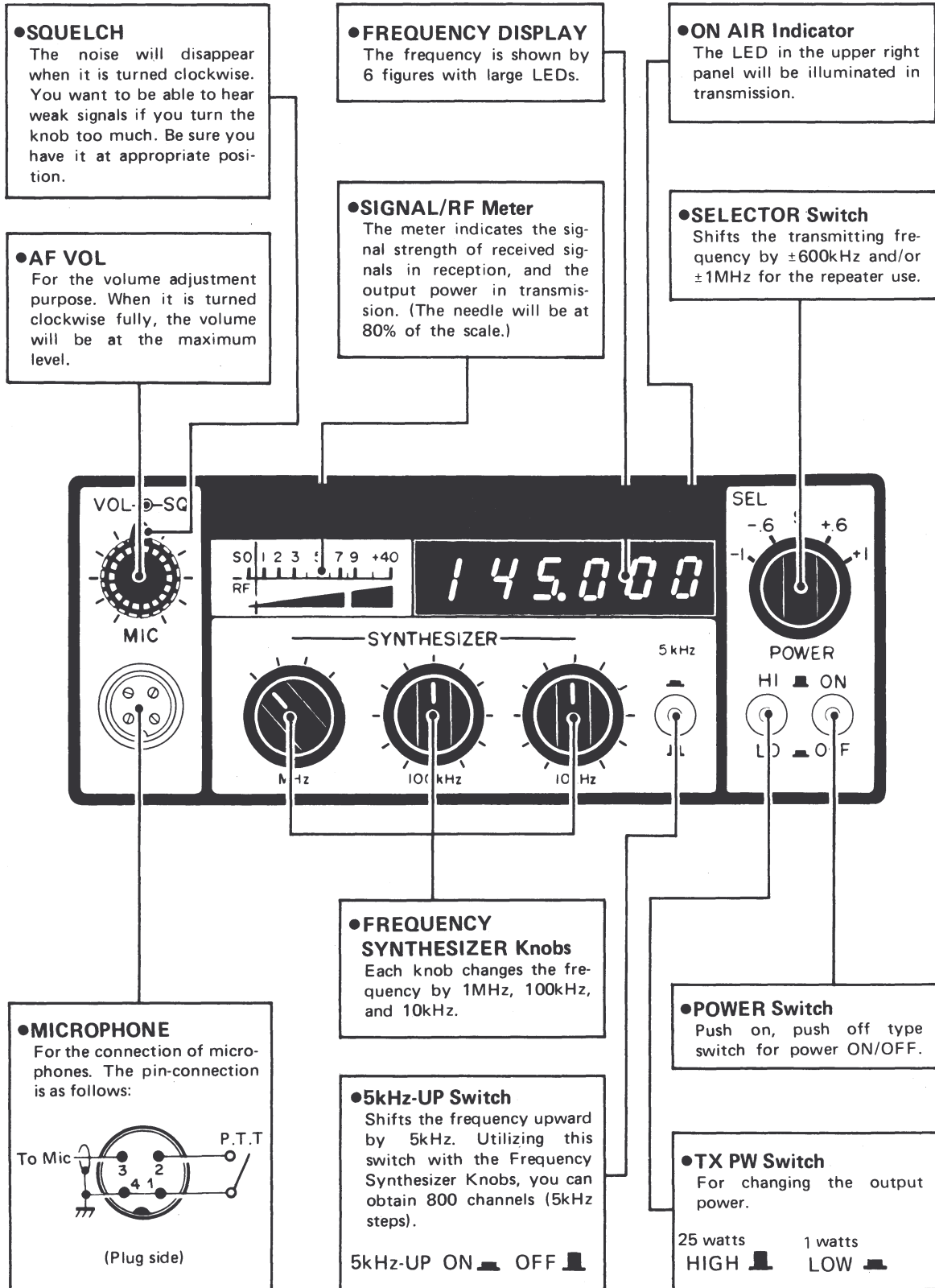

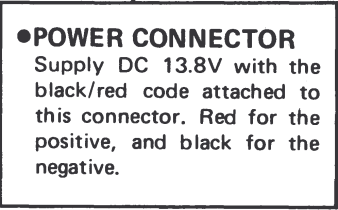
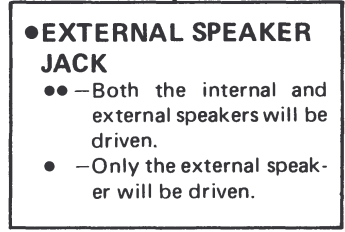
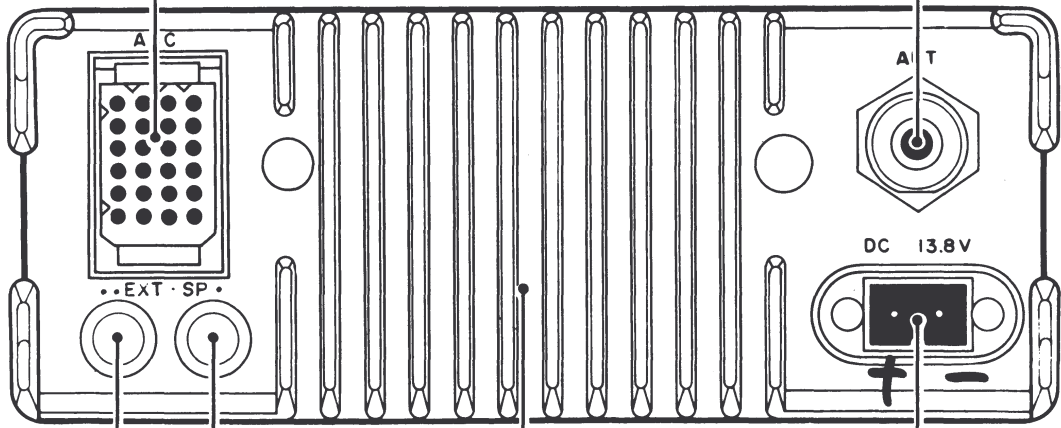
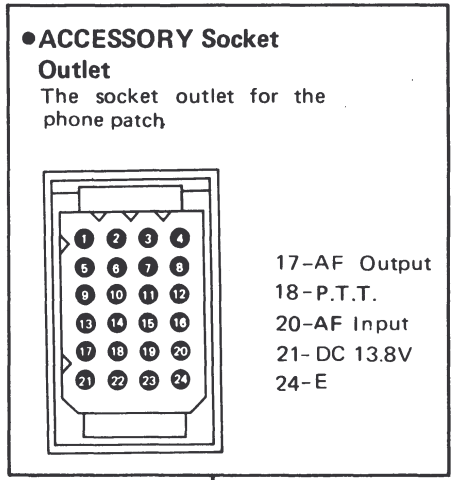

# INTERNAL VIEW LOCATION

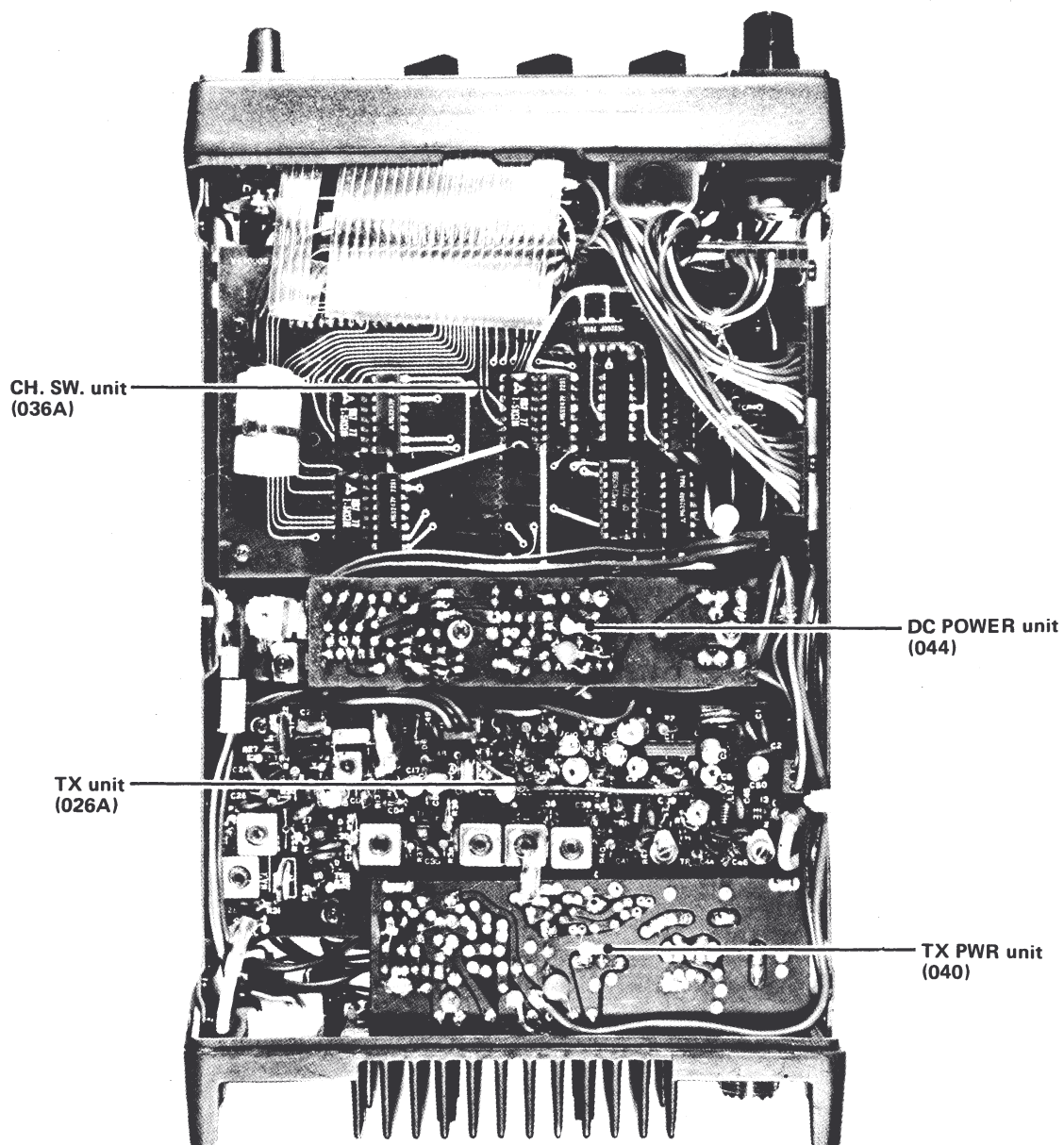

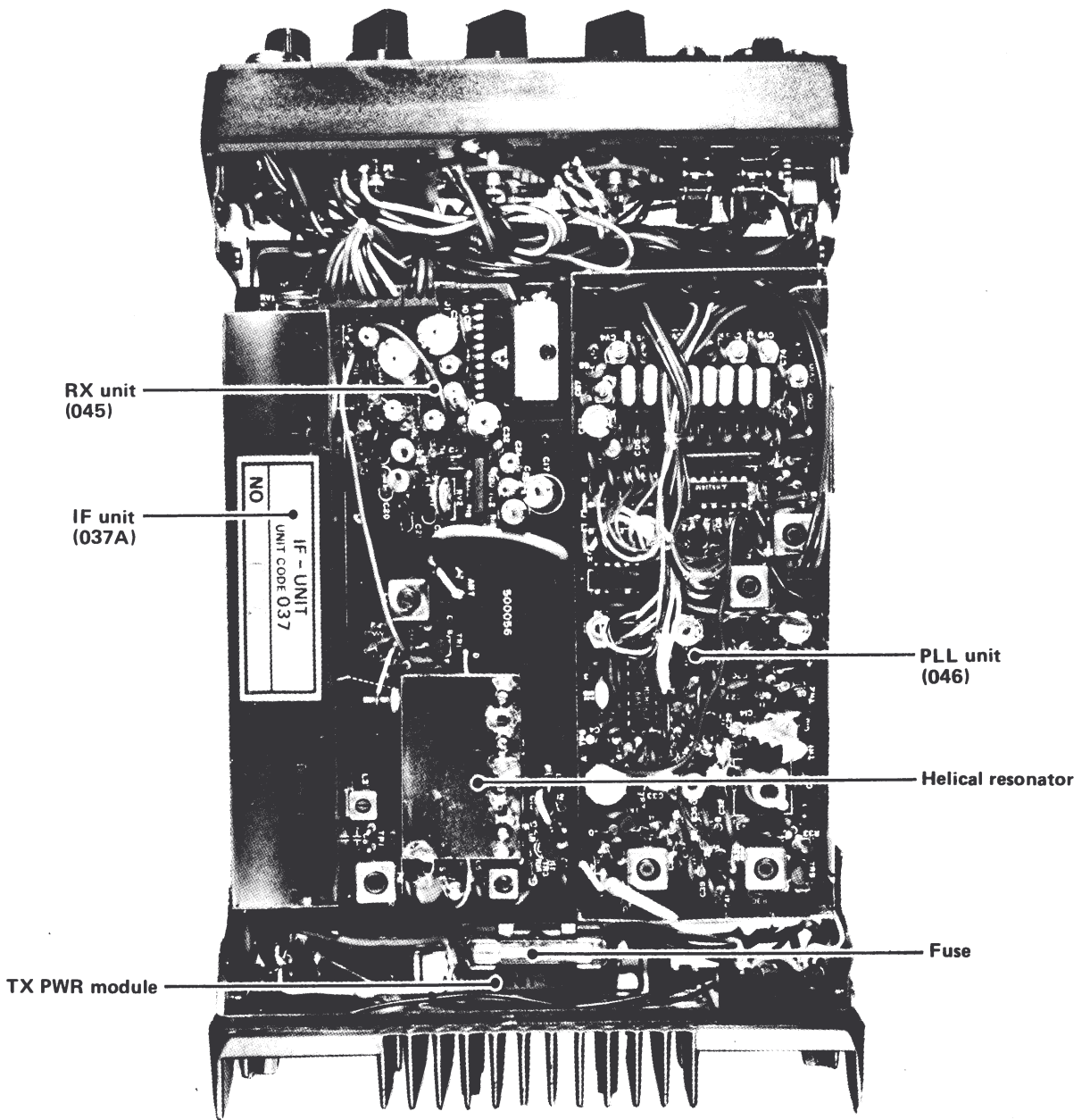

# OPERATION

## ■ Vehicle Operation

### 1) Mounting Position

The best possible positions for the mounting are shown in Fig. 1. Do not expose the set to direct sunlight.

Be careful not to keep the set too warm during summer.

### 2) Mounting

Be sure that your car is negative grounded. If your car is positive grounded, you must absolutely insulate the set from the body. So, consult your dealer in that case.

Fig. 2 shows how the set is to be mounted. Mount your set as shown in Fig. 2.

DC power can be obtained from the cigarette lighter. However, the direct wirings from the battery are recommended for noise elimination.

### 3) Antenna

As the output impedance of the set is 50 ohms, use 50-ohm coaxial cables.

The cables should be short as much as possible.

## ■ Fixed Operation

Avoid using the set in hot, humid, dusty places. An airy, dry place is ideal for its operation.

Do not expose the set to the direct sunlight. DC 13.8V (6A or more, regulated) is required as the power supply.

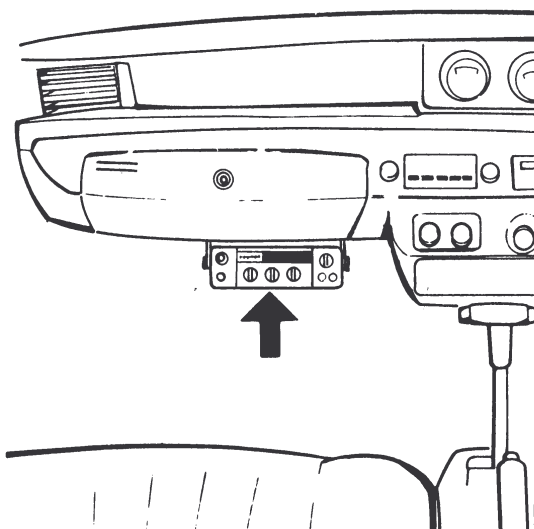

Fig. 1 An example showing mounting position

## ■ Reception

The controls on the front panel of the set must be preset as shown in the table below.

POWER switch	OFF
VOLUME knob	Turn counterclockwise fully.
SQUELCH knob	Turn counterclockwise fully.
SELECTOR switch	S

1) After all the receiving preparations are done, turn the power switch ON. Now, the set is ready for FM reception.

2) Turn the three SYNTH knobs to the desired receiving frequency until it is displayed. (See Fig. 1.)

3) As the VOLUME knob is slowly turned clockwise, you will hear noise or signals. Set the knob to the best position.

4) If there are no signals on the selected receiving frequency, plain noise can be heard. In such a case, turn the SQUELCH knob clockwise until the noise is erased. Do not turn the knob beyond the point where the noise is erased because it will also block weak signals.

## ■ Transmission

1) Adjust the set to your desired frequency, push the PTT switch on the microphone to make it ready for sending (transmission). At this instant, the ON AIR lamp lights.

2) If the RF meter reads 8 or over, you can start talking with the other party. In case of QSO with a local station, LOW output power is sufficient.

When the RF meter reads far less than 8, check the antenna system.

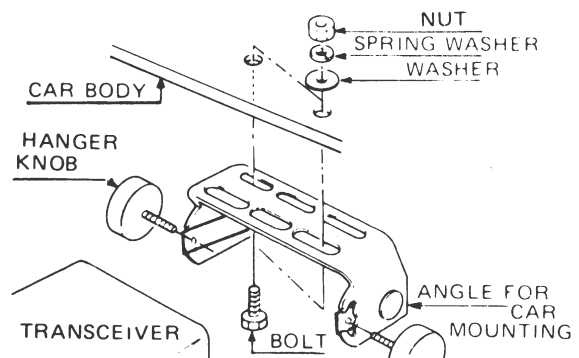

Fig. 2 Mounting method



# CIRCUIT OPERATION

The set consists of 7 units, each of which has its own function. With this, the maintenance can be done easily, and the quality of the set can be unified completely.

## ■ PLL Unit (046)

This unit oscillates the frequency of 127.1 to 131.1MHz (10kHz step), according to the digital signal from the CH-SW unit. The output of this oscillator will be provided to TX, RX units as Lo signals.

The 10kHz and 100kHz signals from the CH-SW unit are fed through a code converter (IC2, IC3), then to ICS1. The ICS1 oscillates 10.240MHz and divides it into 10kHz. Detects the phase difference between this divided 10kHz and the 10kHz-output of a programmable divider.

The output signal from the phase comparator (PD) of ICS1 is fed through the lag lead filter (R2, R3, C5, C6), and to CD1. Then it controls the frequency of the VCO oscillator (TR1).

The output signal of the VCO (127.1 to 131.1MHz) is to be converted to 1.28 to 2.27MHz by a mixer (TR4). It is, then, divided into 1/128 to 1/227 by the programmable divider of ICS1.

Local signal for the mixer (41.92 to 42.941 MHz) is obtained by a third-overtone oscillator (TR10). The 1MHz signal from the CH-SW unit changes over crystals by diode-switchings.

In order to stabilize the output frequency of the VCO, CD2 controls the free-running frequency.

TR7 switches the free-running frequency by 1MHz.

The output signal of the VCO is finally fed through buffer amplifiers (TR8, 9, 11), and is provided to TX, RX units.

## ■ TX Unit (026A)

Voice signals from a microphone is amplified by IC Amp (IC1) up to the limiting level of an IDC circuit (CD1, 2), and then is fed through an active filter (TR2, 3kHz cut off), it modulates a 16.9MHz crystal oscillator (TR3).

Then, the 16.9MHz FM signal is supplied to a balanced mixer (2 FET's, TR5, 6) with the output signal from the PLL unit (127.1 to 131.1MHz).

The output signal of the mixer (144 to 148MHz) is now fed through a band pass filter, and is amplified to approx. 300m watts by 2 stage amplifiers (TR8, 9).

## ■ TX PWR Unit (040)

The signal from the TX unit now drives a RF power module (A1). The output power is switched over by a power control transistor (TR4) to 1 or 10watts/1 or 25watts.

From the output of this module, the forward and reflected powers are detected with toroidal coils. The forward power is fed to RF output meter, and the reflected power switches the power control transistor (TR4) for the protection of the final transistor. Suprious is eliminated by a 3 stage low pass filter.

For an antenna switching over, a transistor (TR3) and diodes (CD1 to 6) are used instead of a relay.

CD9 and CD10 are protection diodes for RX front end.

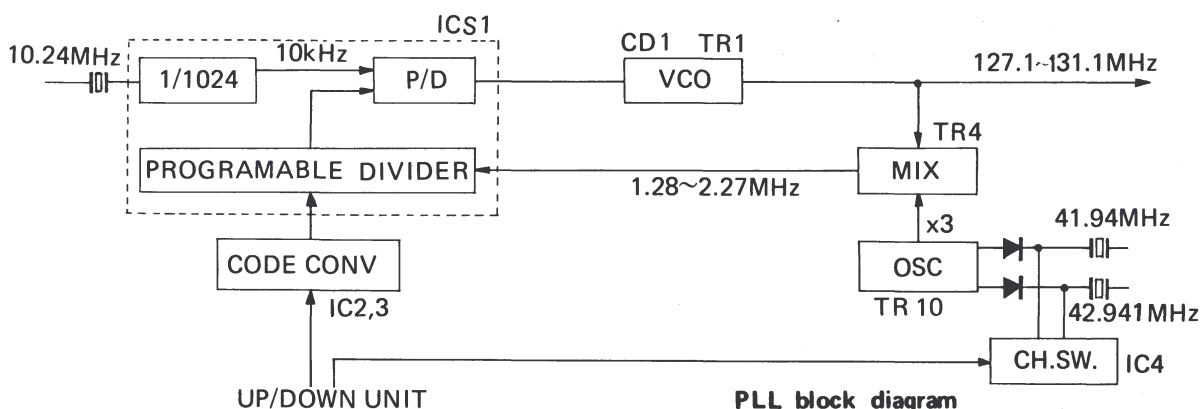



■ **POWER SUPPLY Unit (044)**

DC 13.8V line voltage is transferred and/or regulated here to supply appropriate voltages to each unit.

Regulated 9V voltage is obtained by TR1, CD1, 2, 3.

Regulated 5V with over current limiter is obtained by an IC voltage regulator (IC1). 9V voltage for TX, RX unit is controlled by TR1, 2, 3.

■ **RX Unit (045)**

This unit contains the following circuits; IF unit (A1), RF amplifier with a 4 stage helical resonator (TR1), dual gate MOS FET mixer (TR2), Lo amplifier (TR3), IC squelch amplifier (IC2) and AF amplifier (IC1).

In 16.9MHz IF unit (037A), 2 crystal filters (HCM type) are used to eliminate spurious. The 16.9MHz signal is to be converted into 455kHz with the output of the 2nd Lo (TR3). The 2nd IF consists of ceramic filters (FL2), IC IF amplifiers (IC1, 2) and a ceramic discriminator (DX1).

■ **CH-SW Unit (036)**

This unit sums up the signal from the frequency synthesizer knobs and the one from the SELECTOR switch, and displays the frequency, too.

IC1 and IC2 are for summing up the selector codes.

IC3, IC4, IC5 are for the frequency display.

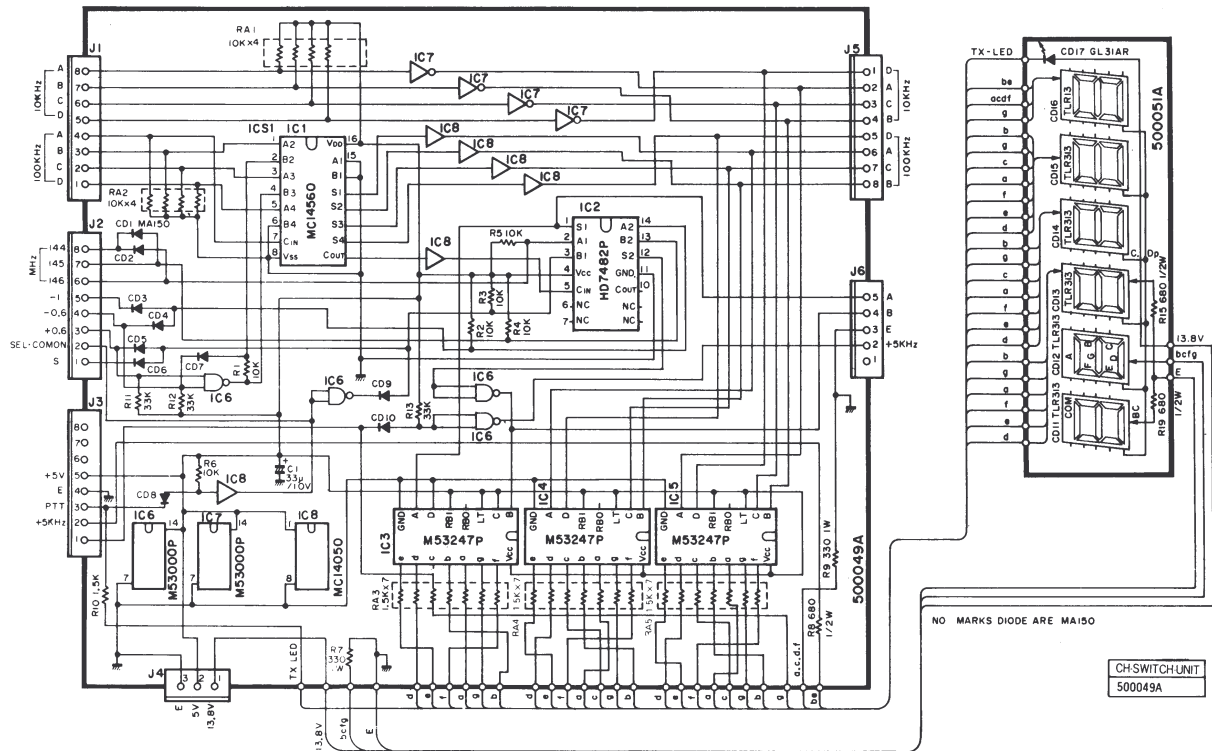

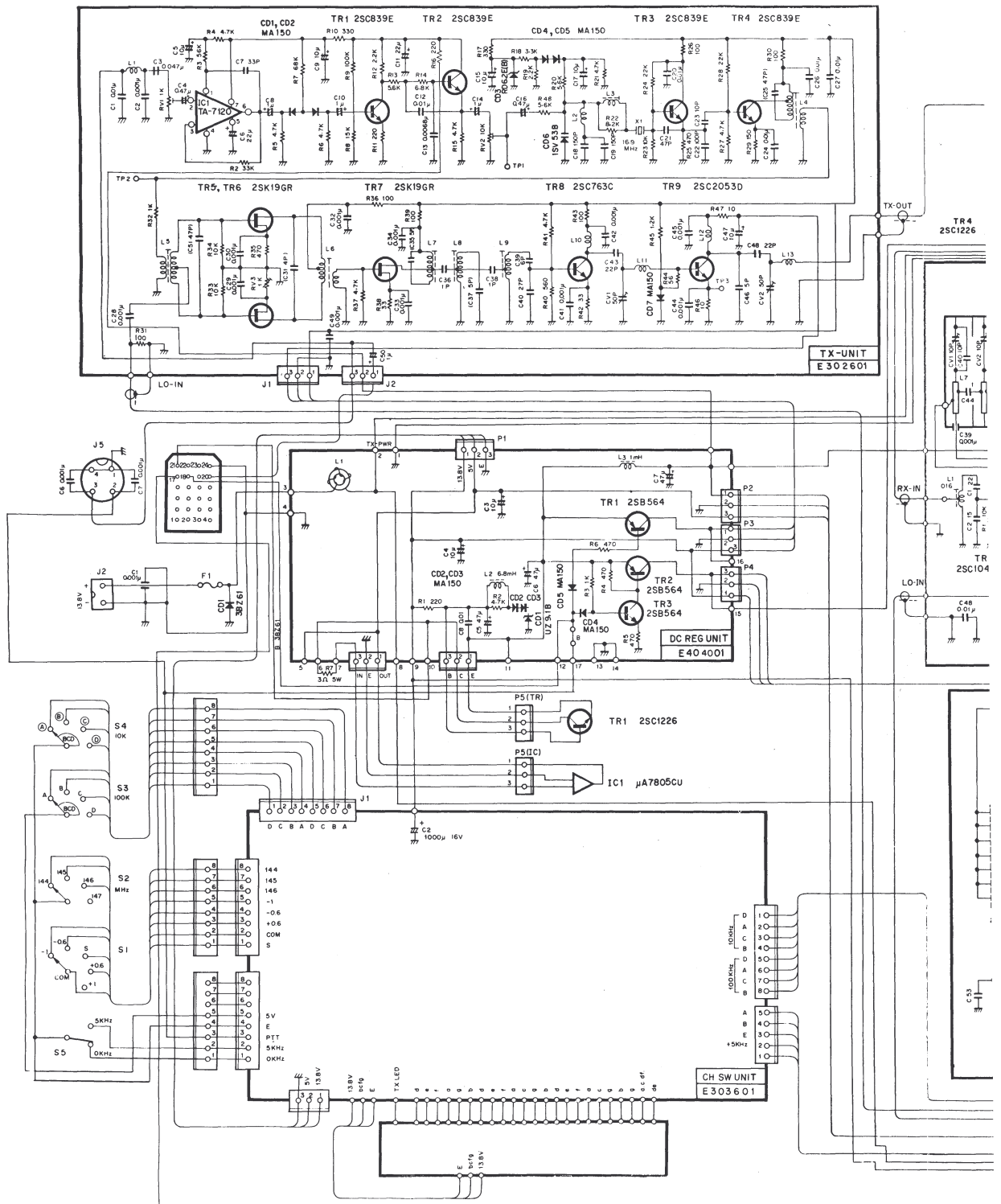

# SCHEMATIC DIAGRAM

THIS SCHEMATIC DIAGRAM IS SUBJECT TO CHANGE WITHOUT NOTICE.

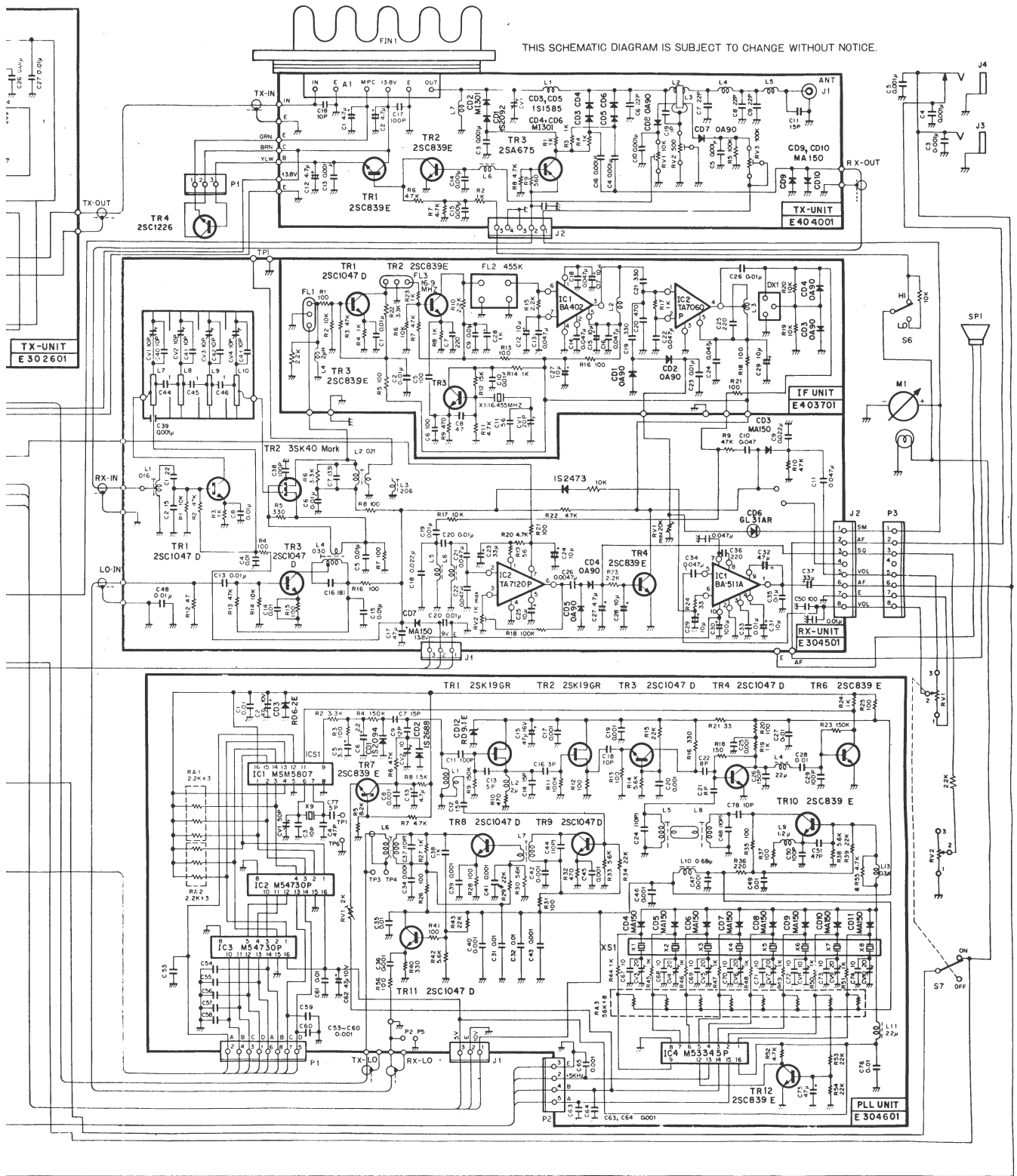

# BLOCK DIAGRAM

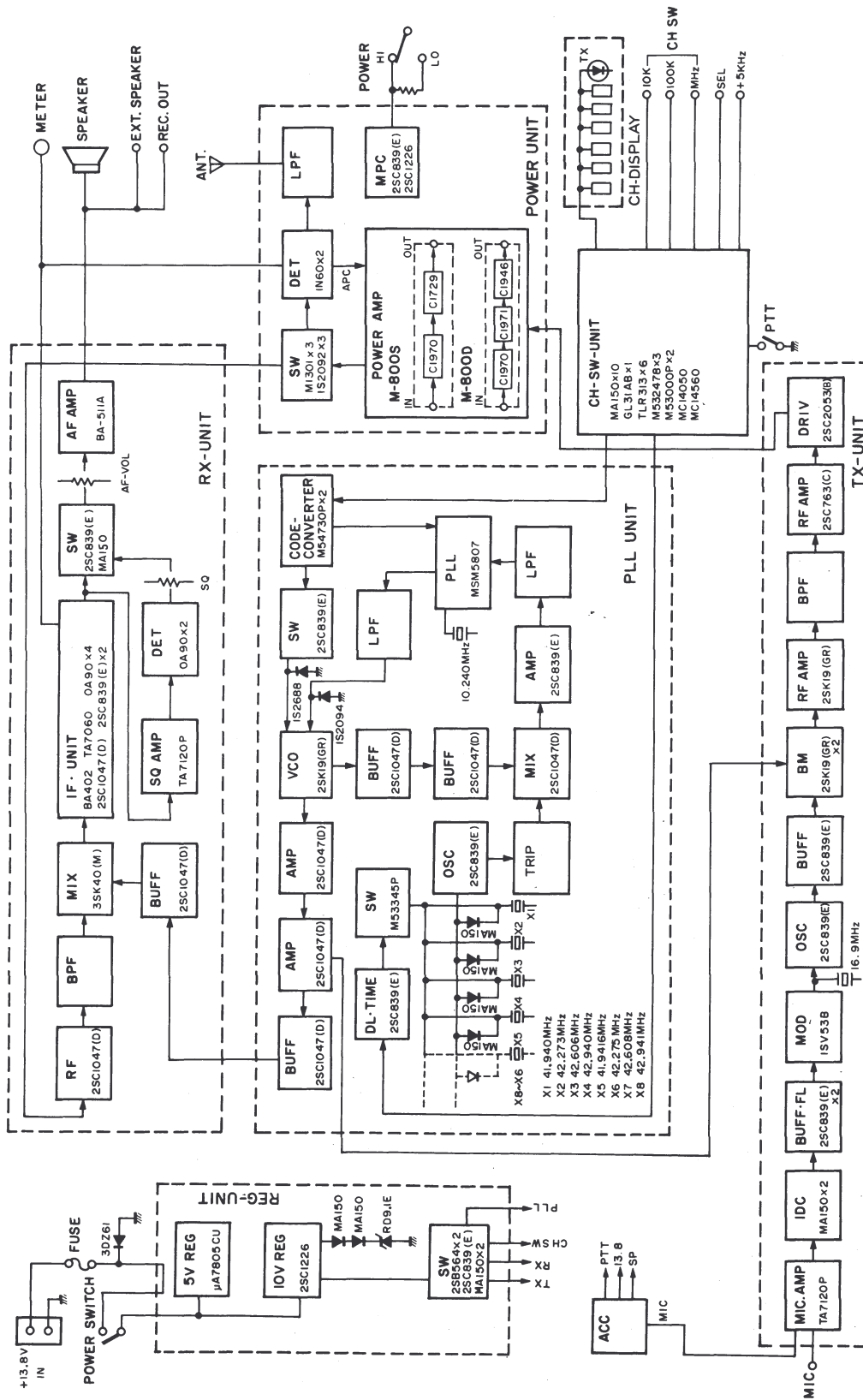

# SPECIFICATIONS

## ● General Specifications

Frequency Range:	144MHz to 147.995MHz
No of Channels:	800 channels (5kHz-steps)
Selection Method:	A rotary switch and a push switch
Emission:	F3
Antenna Impedance:	50 ohms, unbalanced
Power Source:	13.8V (D.C.) Negative grounded
Current Consumption:	
at transmit	MAX. Approx. 6A MIN. Approx. 1.5A
at receive	MAX. Approx. 1.5A MIN. Approx. 1.0A
Number of Semicon- ductors:	32TR's, 6FET's, 18IC's, 8LED's, 52 diodes.
Dimension:	W. 162mm, H. 70.5mm, D. 260mm
Weight:	3.0Kg

## ● Transmitting Section

Output Power:	25W type 1/25watts
Modulation:	Variable reactance fre- quency shift

## Max Frequency

Deviation:	±5kHz
Suprious Level:	-60dB or less
Microphone	600 ohms Dynamic, with P.T.T. switch
Microphone Sensitivity:	-45 dBm

## ● Receiving Section

Receiving System:	Double super heterodyne
I.F. Frequency:	16.9MHz (1st IF), 455kHz (2nd IF)
Sensitivity:	-2 dBμ or less (NQ 20dB)
Squelch Sensitivity:	-5dBμ
Image Ratio:	-60dB or less
Spurious Ratio:	-60dB or less
Selectivity:	±6kHz or more (at -6dB) ±12kHz or less (at -60dB)
A.F. Output Power:	1.2W (10% distortion, 8 ohms)
A.F. Output Impedance:	8 ohms