

ALDA 103  
Amateur Band Transceiver  
Maintenance Manual

80 meters 40 meters 20 meters  
USB LSB CW

**alda** communications inc.  
215 El Centro, Oceanside, California 92054 U.S.A.

## INDEX

	PAGE		PAGE
<b>Illustrations</b>		<b>Chapter 5 — Voltage Charts/Test Points</b>	
Alda 103 Transceiver .....	1	PC 101 .....	13
Interior View .....	2	PC 201 .....	13
<b>Chapter 1 — Specifications</b>		PC 301 .....	14
General Specifications .....	3	PC 501 .....	14
Receiver Specifications .....	3	PC 601 .....	14
Transmitter Specifications .....	3	Voltage Charts Notes .....	14
Optional Accessories .....	3	PC 101 Test Points .....	15
General Description .....	4	PC 201 Test Points .....	16
Special Features .....	4	PC 301 Test Points .....	17
<b>Chapter 2 — Block Diagrams and Brief Description</b>		<b>Chapter 6 — Parts Lists</b>	
Block Diagrams .....	5	PC 101 Parts List .....	18-20
Receive Condition .....	5	PC 201 Parts List .....	20-21
Transmit Condition .....	5	PC 301 Parts List .....	22-24
Brief Description .....	6	PC 401 Parts List .....	24-25
Receive Condition .....	6	PC 501 Parts List .....	25-26
Transmit Condition .....	6-7	PC 601 Parts List .....	26-27
PC 701 Noise Blanker .....	7	PC 701 Parts List .....	27-28
PC 801 Crystal Calibrator .....	7	Electrical & Chassis Parts List .....	28-29
PS 115 Power Supply .....	7	Chassis & Mechanical Parts List .....	29-30
PS 130 Power Supply .....	7	PC 801 Parts List .....	30
<b>Chapter 3 — Functional Description</b>		PS 115 Parts List .....	30
Receive Condition .....	8-9	<b>Chapter 7 — Diagrams</b>	
Transmit Condition .....	9-10	PC 101 .....	31
CW Transmit Condition .....	10	PC 201 .....	32
Control Circuits .....	10-11	PC 301 .....	33
Accessories .....	11	PC 401 Diagram and Chassis Wiring .....	34
<b>Chapter 4 — Alignment and Adjustment</b>		PC 601 .....	35
VFO .....	11	PC 701 .....	35
IF Alignment PC 101 .....	11	PC 801 .....	36
RF Alignment PC301 .....	11-12	PC 501 .....	36
Balanced Mixer Adjustment PC 301 .....	12	PS 115 Diagram and Description .....	37
ALC Adjustment .....	12	PS 130 Diagram and Instructions .....	38
Meter (TX MODE) Adjustment .....	12	PC 801 Installation Instructions .....	39
Carrier Balance Adjustment .....	12	S07 Accessory Socket Connections .....	40
Crystal (BFO/CARRIER) Adjustment .....	12		
CW Tone Oscillator Adjustment .....	12		
P.A. Idle Bias Adjustment .....	12		

WALTER  
 ROBERT E. STECHHOFFER  
 2380 37th St. # 15  
 Evans, Cal. 90620

Alda Communications Inc.  
 218 El Centro Avenue, Colton, CA 92316, U.S.A.

ALDA 103's quality engineering gives you all these convenient features:

OPTIONAL NOISE BLANKER —  
easily installed at any time by simply  
slipping in modular circuit card.

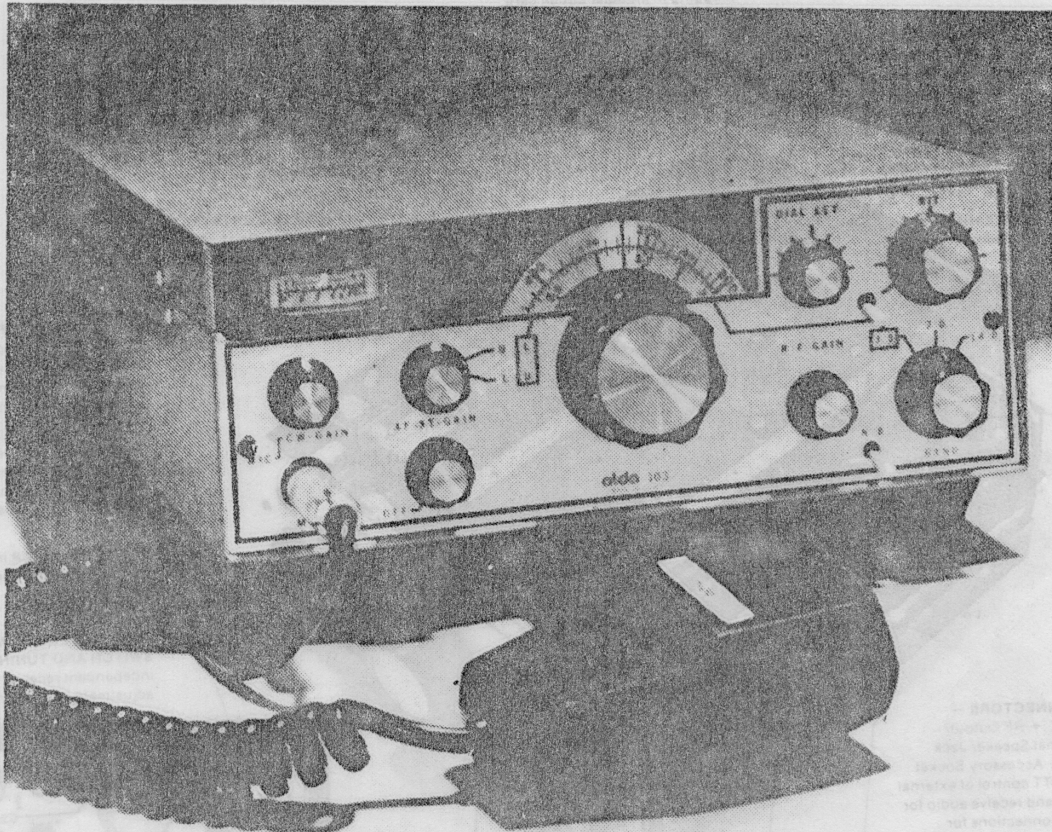

Alda 103 Amateur HF SSB/CW Transceiver

DUAL SPEED VFO DIAL KERNER —  
allows for both the narrow and wide  
bandwidths of the 103.

OPTIONAL CRYSTAL CALIBRATOR  
can be easily added. Three-position slide  
switch — CW, 10 kHz, 100 kHz — located  
under control panel.

SEMI BREAK-IN CW — TX may hold  
circuit stays energized between letters  
and automatically reverts to receive after  
pause between words.

UPPER LOWER OR SWITCH ONLY —  
this is designed to allow the CW  
operator to receive, key or transmit, or  
on CW mode switch is required.

AUTOMATIC INTERNAL ANTENNA  
SWITCHING — antenna control relay  
is located on back panel for automatic  
operation of external handwired  
antenna or remote-controlled  
antenna tuner.

ALL-ALUMINUM CHASSIS —  
lightweight and corrosion-resistant  
provides excellent shielding.

Alda 103 Interior View of Modular Control Section

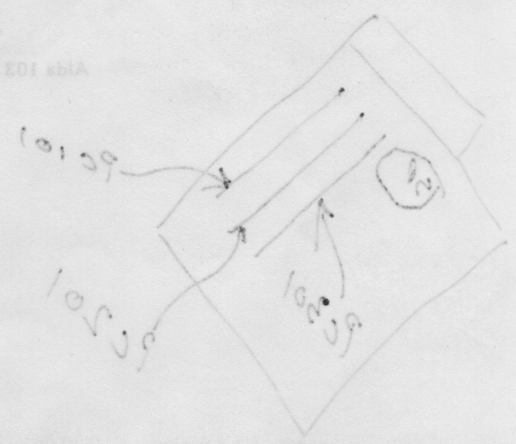

ALDA 103's quality engineering gives you all these convenient features:

**OPTIONAL NOISE BLANKER** — easily installed at any time by simply plugging in modular circuit card.

**BROADBAND POWER AMPLIFIER** — all-solid state Push-Pull Final Stage; requires no transmitter tuning whatsoever.

**EXTRA LARGE POWER AMPLIFIER HEATSINK** — 7-3/16" x 3-1/4" (182 mm x 82.5 mm) for efficient heat dissipation.

**TRANSMITTER MODULE HINGES** — DOWN for easy accessibility.

**BOTTOM-MOUNTED BUILT-IN SPEAKER** — 3" x 3" with rear panel jack for external speaker.

**BUILT-IN CW MONITOR** provides adjustable level on front-panel with full monitoring of CW tone.

**6-POLE CRYSTAL FILTER** with 2.5 kHz bandwidth at -6 dB to provide excellent audio characteristics for transmit as well as receive.

**HIGH STABILITY VFO** — less than 100 Hz drift from a "cold" start at room temperature. Heavy-gauge drawn aluminum cover for maximum protection in mobile applications.

**MODULAR PLUG-IN CIRCUIT BOARD ASSEMBLY** increases ruggedness required for mobile operation and assures easy serviceability.

**FRONT-PANEL METER** indicates level of received signal and transmitter relative output power.

**SEPARATE FRONT PANEL RIT ON/OFF SWITCH AND TUNING CONTROL** for independent receiver frequency adjustment  $\pm 500$  Hz nominal.

**REAR PANEL CONNECTORS** — DC Power Input • RF Output/Antenna • External Speaker Jack • CW Key Jack • Accessory Socket which is used for PTT control of external amplifier; transmit and receive audio for one patch, and connections for optional accessories such as remote control and digital display.

**SEMI BREAK-IN CW** — T/R relay hold circuit stays energized between letters and automatically reverts to receive after pause between words.

**ALL-ALUMINUM CHASSIS** — lightweight and corrosion-resistant in severe environmental conditions.

**AUTOMATIC INTERNAL ANTENNA SWITCHING** — antenna control wafer is located on bandswitch for automatic changeover of external bandswitched amplifier or remote-controlled antenna tuner.

**OPTIONAL CRYSTAL CALIBRATOR** can be easily added; three-position slide switch — OFF/10 kHz/100 kHz — located under center of front panel.

**DUAL SPEED VFO DIAL VERNIER** — extra smooth zero backlash ball action tuning with 6 to 1/30 to 1 dial drive.

**UPPER/LOWER SB SWITCH ONLY** — unit automatically switches to CW operation whenever key is pressed, so no CW mode switch is required.

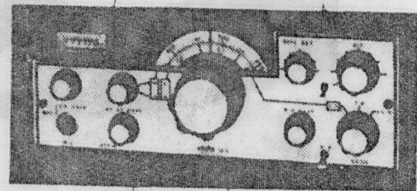

Alda 103 Interior View of Modular Construction

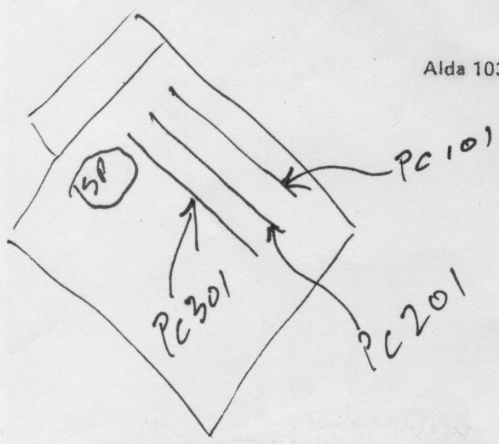

## CHAPTER 1 SPECIFICATIONS ALDA 103

### GENERAL

**Frequency Coverage:**  
3.5 Mhz to 4.0 Mhz.  
7.0 Mhz to 7.5 Mhz.  
14.0 Mhz to 14.5 Mhz.

**Frequency Control:**  
VFO covering the frequency range 5.0 Mhz to 5.5 Mhz.

**Frequency Stability:**  
Less than 100 Hz drift per hour from a cold start at room temperature.  
Less than 100 Hz drift per 10 degree temperature change.

#### Modes of Operation:

SSB, both Upper and Lower without accessories.  
CW. May be transmitted in either sideband without accessories.

Note that CW Tx output is automatically offset so that the listener need not retune the receiver when switching from SSB.

#### Supply Voltage and Power Requirements:

13.6 volts, negative ground only, 18 amps. (Accessory AC supply available.) Note: A supply voltage as high as 16 volts may be used without damage to the transceiver.

#### Size:

3 1/4" high, 9" wide, 12 1/2" front to back including knobs.

#### Weight:

8 1/4 lbs.

### RECEIVER

Straight through to 9 Mhz IF on 80 meters, 40 meter and 20 meter signals converted to 3.5 Mhz to 4 Mhz and then 9 Mhz.

#### Signal to Noise ratio:

Better than 10 db S+N/N for 0.5 uv signal.

#### Sensitivity:

More than 2.0 watts audio output for 0.5 uv input signal.

#### Audio Output:

More than 3 watts to internal or external 3 ohm speaker.

#### Audio Distortion:

Less than 5% at 3 watt output level.

#### AGC:

Less than 12 db variation in audio output level when the input signal is varied from 5 uv to .1 volt.

#### Intermodulation Intercept Point:\*

Better than +10 dbm.

#### Image Rejection:

80 meters. Better than -100 db.  
40 meters. Better than -100 db.  
20 meters. Better than -65 db.

#### IF Feedthrough:

80 meters. Better than -110 db.  
40 meters. Better than -80 db.  
20 meters. Better than -75 db.

#### Spurious Signals:

80 meters. Better than -80 db.  
40 meters. Better than -80 db. (Except for one 500 KHz higher than the dial indicated frequency at -65 db.)  
20 meters. Better than -70 db.

### TRANSMITTER

#### Power Input:

SSB. In excess of 200 watts PEP all bands.  
CW. Adjustable to in excess of 200 watts.

#### Unwanted Sideband Suppression:

Better than -65 db measured at 1000 Hz.

#### Harmonics Outputs:

Better than -40 db below 30 Mhz.  
Better than -60 db above 30 Mhz.

#### Spurious Outputs:

Better than -40 db below 30 Mhz.  
Better than -60 db above 30 Mhz.

#### Third Order Distortion:

Better than -26 db at the 100 watt level of output on 80 and 40 meters.  
Better than -26 db at the 85 watt level of output on 20 meters.

### OPTIONAL ACCESSORIES

ALDA PS115 Power Supply. 115/230 volts 50/60 Hz.  
(Portable—Average Duty—Unregulated)

ALDA PS130 Power Supply. 115 or 230 volts 50/60 Hz.  
(Base Station—Heavy Duty—Regulated)

ALDA PC701 Noise Blanker Module

ALDA PC 801 Crystal Calibrator Module

(Switchable 100/25 KHZ Output)

ALDA PC 701 Noise Blanker Module

\*The intercept point was measured with both received signals within the receiver IF passband.

NOTE: The above specifications are subject to change without notice.

### General Description

The ALDA 103 Amateur HF SSB/CW Transceiver is a medium power unit for mobile, portable or base station operation. The transceiver provides operation on three bands: 80, 40 and 20 meters.

The transceiver may be powered from any suitable +13.8 volt source, negative ground. The source must be capable of supplying up to 18 amperes on peaks and 10 amperes average. The power supply voltage may fluctuate between 11 and 17 volts without damage or mis-operation of the transceiver except that transmitter power output may fall below the specified minimum if the supply voltage drops below 13.8 volts.

When operating portable or from a vehicle or boat or aircraft using a 12 volt negative ground system, no additional power supply is necessary. When installed as a fixed station, an accessory power supply is required to convert the standard 115/230 volt, 50/60Hz to a nominal 13.8 volts DC. Two such power supply models are the Alda PS 115 for fixed or portable, average duty operation and the Alda PS 130 for fully regulated, heavy duty operation.

The transceiver is designed to operate directly into a resonant 50 ohm antenna system or into an antenna tuner. Control wires are brought out to a rear mounted socket so that an antenna tuner may be located near the antenna and remotely controlled from the transceiver. This feature is of particular value for maritime mobile operation where either a single vertical or long wire (Back Stay) type antenna must be utilized.

### Special Features

- All Solid State – 80, 40 and 20 meters.
- Totally Broadbanded – no tune-up whatsoever.
- Compact Size – only 3-1/4 in. x 9 in. x 12-1/2 in.
- Lightweight – 8-1/4 lbs. Perfect for Mobile or Portable.
- Power Input – 250 watts PEP or Average.
- Selectable Sideband – (CW operation on either sideband for QRM Evasion.)
- CW Keying – Semi-Break-in with adjustable sidetone level.
- Complete with mobile microphone, mobile mounting bracket and mobile power cord with fuse and fuse block.
- Internal Zener Regulation allows DC input voltage variation from 11 to 17 volts without mal-operation (except for lower transmit output power).
- Particularly rugged construction making the transceiver perfectly suited for mobile use and rough emergency use.
- Extended frequency coverage to 4.050, 7.5 and 14.5 MHz for additional utilization on MARS, CAP, etc.
- Well suited for base station operation. To operate CW, merely press the morse key. No mode switch to bother with.
- Receiver has exceptional immunity to front end overload.
- Plug-in Modular printed circuit boards for easy maintenance. Boards are made of solder plated epoxy fiberglass. No hydroscopic materials are used.
- Complete accessory support including plug-in mobile noise blanker, crystal calibrator-dual output 25/100 KHz, PS 115 fixed or portable, average duty power supply or PS 130 fully regulated heavy duty power supply.
- Additional new accessories to include Remote VFO, Digital Readout and ten channel crystal oscillator.
- Maritime use enhanced by built-in switching of optional remote controlled antenna tuner for vertical whip or long wire (Back Stay) type antenna.
- Receiver Nominal Current Drain of 400 MA. provides energy saving monitoring capability.
- Emergency use enhanced by mic gain controlling transmit output power in SSB and CW. Use only the required amount of power to maintain communication while conserving battery energy (or if you wish, operate QRP).
- Very superior VSWR protection circuitry allows safe operation into mis-matched antennas. (Typically nominal output 80 watts at 3:1 VSWR and no worries of power amplifier transistor burn-out.)
- Front Panel Meter provides S-meter indication during receive and relative output indication during transmit.
- Special Braille Dial available at no extra cost.
- Maximum allowable power input for novice and technician on 80 and 40 meters.

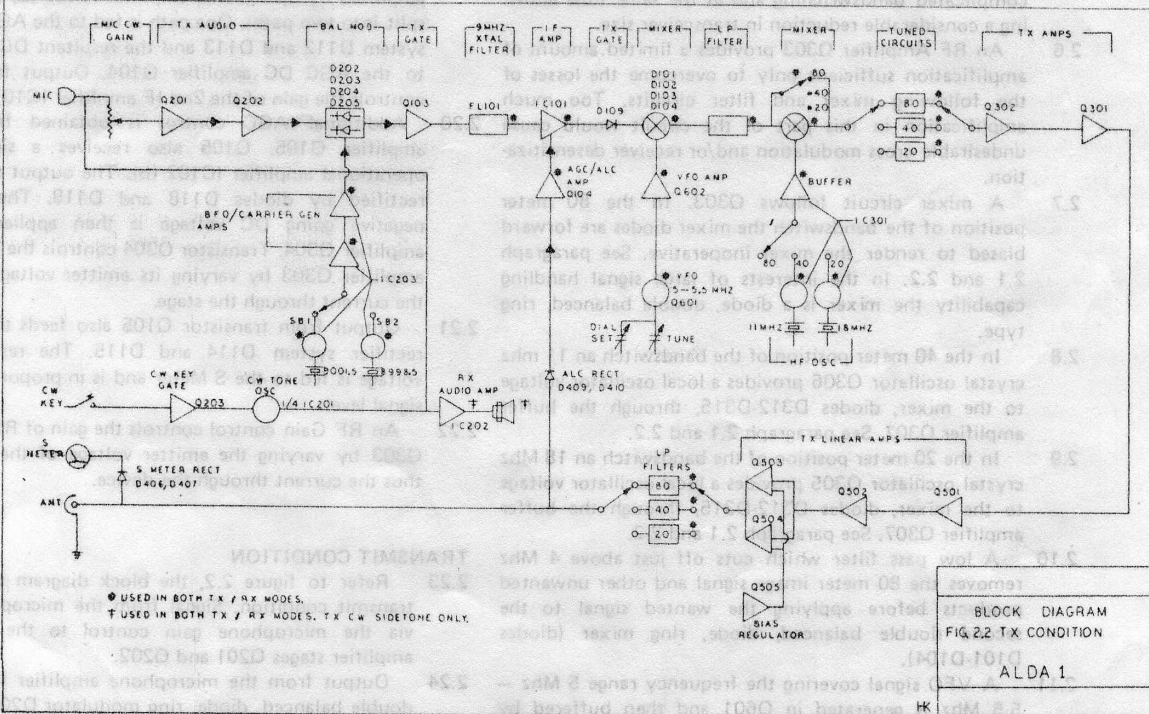
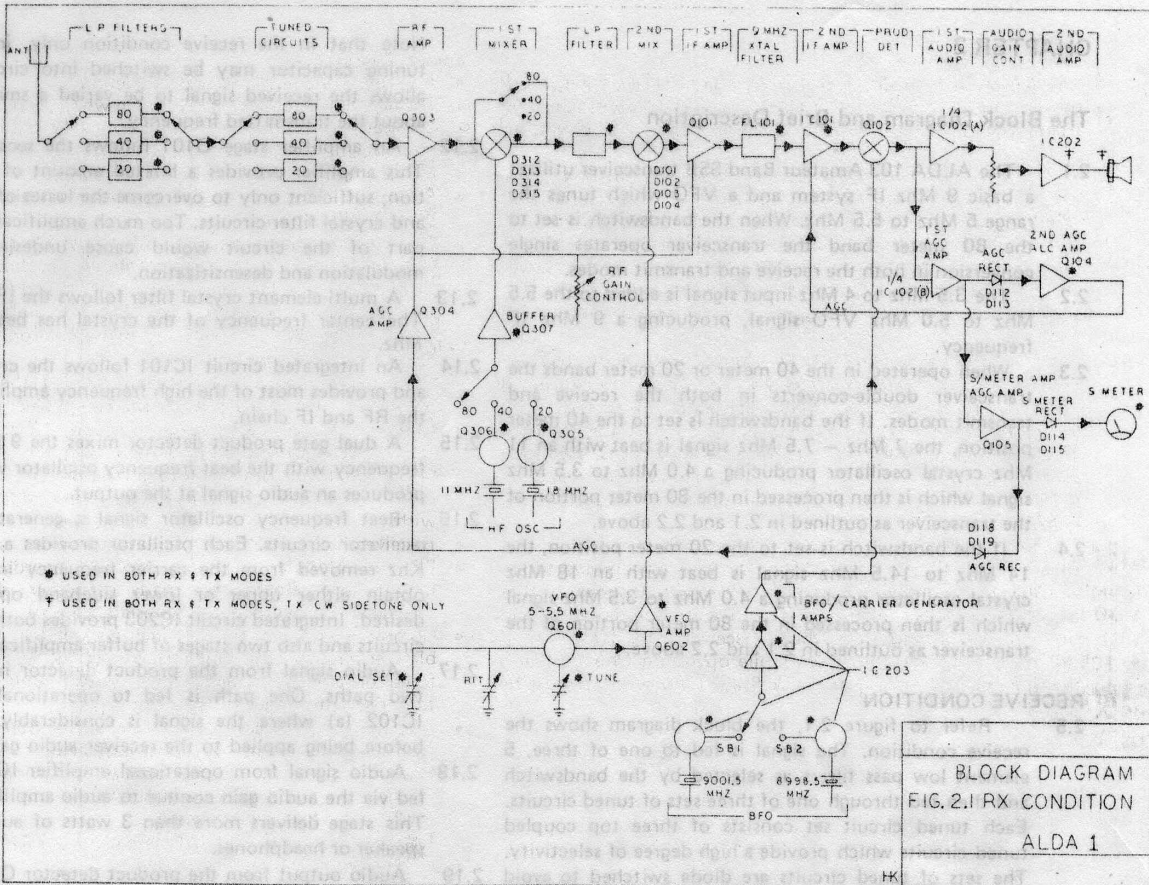

## CHAPTER 2

### The Block Diagram and Brief Description

- 2.1 The ALDA 103 Amateur Band SSB transceiver utilizes a basic 9 Mhz IF system and a VFO which tunes the range 5 Mhz to 5.5 Mhz. When the bandswitch is set to the 80 meter band the transceiver operates single conversion in both the receive and transmit modes.
- 2.2 The 3.5 Mhz to 4 Mhz input signal is added to the 5.5 Mhz to 5.0 Mhz VFO signal, producing a 9 Mhz IF frequency.
- 2.3 When operated in the 40 meter or 20 meter bands the transceiver double-converts in both the receive and transmit modes. If the bandswitch is set to the 40 meter position, the 7 Mhz - 7.5 Mhz signal is beat with an 11 Mhz crystal oscillator producing a 4.0 Mhz to 3.5 Mhz signal which is then processed in the 80 meter portion of the transceiver as outlined in 2.1 and 2.2 above.
- 2.4 If the bandswitch is set to the 20 meter position, the 14 Mhz to 14.5 Mhz signal is beat with an 18 Mhz crystal oscillator producing a 4.0 Mhz to 3.5 Mhz signal which is then processed in the 80 meter portion of the transceiver as outlined in 2.1 and 2.2 above.

#### RECEIVE CONDITION

- 2.5 Refer to figure 2.1, the block diagram shows the receive condition. The signal is fed to one of three, 5 element low pass filters as selected by the bandswitch and then fed through one of three sets of tuned circuits. Each tuned circuit set consists of three top coupled tuned circuits which provide a high degree of selectivity. The sets of tuned circuits are diode switched to avoid complicated bandswitching and at the same time allowing a considerable reduction in transceiver size.
- 2.6 An RF Amplifier Q303 provides a limited amount of amplification sufficient only to overcome the losses of the following mixer and filter circuits. Too much amplification in this part of the circuit would cause undesirable cross modulation and/or receiver desensitization.
- 2.7 A mixer circuit follows Q303. In the 80 meter position of the bandswitch the mixer diodes are forward biased to render the mixer inoperative. See paragraph 2.1 and 2.2. In the interests of large signal handling capability the mixer is a diode, double balanced, ring type.
- 2.8 In the 40 meter position of the bandswitch an 11 mhz crystal oscillator Q306 provides a local oscillator voltage to the mixer, diodes D312-D315, through the buffer amplifier Q307. See paragraph 2.1 and 2.2.
- 2.9 In the 20 meter position of the bandswitch an 18 Mhz crystal oscillator Q305 provides a local oscillator voltage to the mixer, diodes D312-D315, through the buffer amplifier Q307. See paragraph 2.1 and 2.2.
- 2.10 A low pass filter which cuts off just above 4 Mhz removes the 80 meter image signal and other unwanted products before applying the wanted signal to the second double balanced, diode, ring mixer (diodes D101-D104).
- 2.11 A VFO signal covering the frequency range 5 Mhz - 5.5 Mhz is generated in Q601 and then buffered by Q602 before being applied to the second mixer circuit.

Note that in the receive condition only, incremental tuning capacitor may be switched into circuit which allows the received signal to be varied a small amount about the transmitted frequency.

- 2.12 An amplifier stage Q101 follows the second mixer. This amplifier provides a limited amount of amplification, sufficient only to overcome the losses of the mixer and crystal filter circuits. Too much amplification in this part of the circuit would cause undesirable cross modulation and desensitization.
- 2.13 A multi-element crystal filter follows the IF amplifier. The center frequency of the crystal has been set at 9 Mhz.
- 2.14 An integrated circuit IC101 follows the crystal filter and provides most of the high frequency amplification in the RF and IF chain.
- 2.15 A dual gate product detector mixes the 9 Mhz signal frequency with the beat frequency oscillator voltage and produces an audio signal at the output.
- 2.16 Beat frequency oscillator signal is generated in two oscillator circuits. Each oscillator provides a signal 1.5 KHz removed from the carrier frequency in order to obtain either upper or lower sideband operation as desired. Integrated circuit IC203 provides both oscillator circuits and also two stages of buffer amplification.
- 2.17 Audio signal from the product detector is split into two paths. One path is fed to operational amplifier IC102 (a) where the signal is considerably amplified before being applied to the receiver audio gain control.
- 2.18 Audio signal from operational amplifier IC102 (a) is fed via the audio gain control to audio amplifier IC202. This stage delivers more than 3 watts of audio to the speaker or headphones.
- 2.19 Audio output from the product detector Q102 is also amplified by operational amplifier IC102 (b) and is then split into two paths. One path is fed to the AGC rectifier system D112 and D113 and the resultant DC signal fed to the AGC DC amplifier Q104. Output from Q104 controls the gain of the 2nd IF amplifier IC101.
- 2.20 Additional AGC control is obtained from AGC amplifier Q105. Q105 also receives a signal from operational amplifier IC102 (b). The output of Q105 is rectified by diodes D118 and D119. The resultant negative going DC voltage is then applied to FET amplifier Q304. Transistor Q304 controls the gain of RF amplifier Q303 by varying its emitter voltage and thus the current through the stage.
- 2.21 Output from transistor Q105 also feeds the S Meter rectifier system D114 and D115. The resultant DC voltage is fed to the S Meter and is in proportion to the signal level.
- 2.22 An RF Gain control controls the gain of RF amplifier Q303 by varying the emitter voltage of the stage and thus the current through the device.

#### TRANSMIT CONDITION

- 2.23 Refer to figure 2.2, the block diagram showing the transmit condition. Signal from the microphone is fed via the microphone gain control to the two audio amplifier stages Q201 and Q202.
- 2.24 Output from the microphone amplifier is fed to the double balanced, diode, ring modulator D202-D205 and mixed with carrier voltage to create a double sideband,



suppressed carrier signal.

- 2.25 Carrier is generated in the BFO/Carrier Generator stages in integrated circuit IC203. See paragraph 2.16.
- 2.26 Double sideband output from the balanced modulator is fed via a transistor gate, Q103, which is on only in the transmit condition, to the crystal filter FL101. The crystal filter removes either the upper or the lower sideband dependent upon which carrier generator crystal is in use as determined by the sideband selector switch on the front panel.
- 2.27 Single sideband output from the crystal filter is amplified by integrated circuit IC101 and is then fed via a diode gate D109, which is on only in the transmit condition, to the mixer diode ring, D101 - D104.
- 2.28 VFO voltage from Q601 and Q602 is mixed with the 9 Mhz IF SSB signal and an output in the 3.5 Mhz to 4 Mhz band is produced.
- 2.29 See paragraph 2.11 for operation of the VFO circuit.
- 2.30 Output from the mixer circuit, in addition to the wanted signal, contains many spurious products including a strong image signal. These products are filtered out or reduced by a low pass filter circuit before being applied to the next mixer stage D312 - D315.
- 2.31 The operation of the 2nd mixer stage has been covered in paragraphs 2.1 through 2.4. In the case of the transmit mode the path through the mixer is in the opposite direction from the receive mode.
- 2.32 For operation of the local oscillators, when operating in the 40 meter and 20 meter bands, see paragraphs 2.8 and 2.9.
- 2.33 Output from the 2nd mixer is fed to one of three sets of tuned circuits each covering the 80 meter, 40 meter and 20 meter bands respectively. The sets of tuned circuits are diode switched to eliminate complicated bandswitching circuitry and unwanted coupling. Each set of tuned circuits consists of three top coupled, parallel tuned circuits which give a high degree of selectivity, further reducing unwanted products generated in the mixer circuits.
- 2.34 Following the tuned circuits are two broadband low level, linear amplifier circuits, Q301 and Q302.
- 2.35 Output from amplifier Q301 is fed via a co-axial cable to the linear amplifier stage, Q501.
- 2.36 Amplifiers Q501 and Q502 both operate class A. Transistor Q502 drives push pull stages Q503 and Q504. Transistor amplifiers Q501 through Q504 are all located on the linear amplifier module, heat sink. The entire amplifier is broadbanded. Push pull operating of the two final amplifiers Q503 and Q504 considerably reduces the even order harmonics making the filtering task of the following low pass filters somewhat easier.
- 2.37 A regulator stage Q505 provides bias to the final amplifier stages. Not shown in the block diagram are two silver-lead diodes which sense the heat generated in the heatsink by the amplifiers and control the bias voltage generated in the regulator stage Q505. The bias is accordingly held fairly constant regardless of heatsink temperature and supply voltage.
- 2.38 Output from the linear amplifier stages is fed to one of three low pass filter circuits. Each filter cuts off just above the appropriate amateur band, thus providing a high degree of harmonic suppression.
- 2.39 CW transmission is accomplished by feeding a high quality 800 Hz tone into the microphone audio amplifier via the microphone gain control. The gain control also controls the CW output level. Not shown in the block diagram is a network of diodes which allows break-in keying. When the key is depressed an automatic delay is provided so that the transceiver will stay in the transmit mode between CW characters and words but will switch to receive between longer pauses.
- 2.40 The CW key controls the gate, Q203. Q203, in turn controls the operational amplifier, 800 Hz oscillator stage, IC201.
- 2.41 CW sidetone is automatically provided when the key is pressed. Tone signal from IC201 is fed to the receiver audio output amplifier IC201 and the level may be adjusted by the receiver audio gain control.
- 2.42 An Automatic level control system has been provided to prevent the transmitter from being driven into an overloaded condition. Output from the transmitter is sampled by rectifier system D409 and D410 and the resultant DC signal amplified by amplifier Q104. Q104, in turn, controls the gain of IF amplifier IC101.
- 2.43 Metering of the transmitter output is accomplished by rectifying a portion of the transmitter output with rectifier system D406 and D407. The resultant DC is fed directly to the meter.
- 2.44 An accessory printed circuit board PC701 noise blanker allows blanking of ignition and other pulse type interference. Noise signals are taken from the 3.5 Mhz - 4 Mhz input to PC101, amplified, rectified and further amplified before being applied to the noise gate Q106 on PC101. Note that the noise blanker uses a system which adjusts to the steady state signal level thus considerably reducing cross modulation, a problem with most noise blankers.
- 2.45 An accessory power supply provides approximately 14.5 volts DC to the transceiver. The supply is a simple full wave rectifier, capacitor/choke filtered system. The supply is not regulated, this not being necessary as the transceiver contains its own regulation.
- The Model PS115 power supply described above is intended for application as a portable, average duty, unregulated power supply.
- 2.46 On accessory printed circuit board PC801, Crystal Calibrator provides a switch selected 100kHz/25kHz output signal which is connected to the receiver input for calibrating the individual bands with the dial set capacitor. The RIT control should be turned off during the calibration.
- 2.47 Accessory Power Supply (Model PS130) consists of a 30 Amp Bridge Rectifier, an operational amplifier, two control transistors and four pass transistors and dual heavy-duty heat sinks. The output voltage is factory adjusted for 13.0 volts at 30 amperes load. The PS130 is intended for application as a base station, heavy duty, fully regulated power supply.

## CHAPTER 3 FUNCTIONAL DESCRIPTION

### RECEIVE CONDITION

- 3.1 Signal from the antenna is applied to Switch Wafer W2 which is part of the Bandswitch, SW1. Wafers 2 and 3 select one of three low pass filters. Each filter is designed to cut off just above the frequency band it is designed to pass.
- 3.2 Output from Wafer 3 is fed through the antenna change over relay RLY401 to printed circuit board PC301.
- 3.3 Signal from the antenna relay is fed through diode T/R switch D302 to the cathodes of three diode switches D304, D305 and D306.
- 3.4 Diode switch D301 closed in the transmit condition is now open.
- 3.5 Diode switch D303 closed in the transmit condition is now open.
- 3.6 PC301 contains 3 sets of tuned circuits, one set for each frequency band. The tuned circuits are diode switched when the bandswitch is rotated. Tuned circuit selection is effected when the bandswitch applies a positive voltage to the anode of the appropriate diode switch. For example, in the 80 meter position of the bandswitch diodes D306, and D309 are forward biased (ON) but the other diode switches D304, D305, D307 and D308 are reverse biased (OFF).
- 3.7 Signal voltage from the diode switches D307 through D309 is next applied to the base of transistor amplifier Q303. The output of this stage drives the mixer transformer L316. Q303 is turned off in the transmit condition by applying a positive voltage from the control line via resistor R319 and diode D311 to the emitter. Making the emitter of this stage positive is the same as making the base negative.
- 3.8 FET transistor Q304, by varying the source voltage of Q303, provides a degree of automatic gain control. Automatic gain control voltage is developed on printed circuit board PC101. See paragraph 3.26.
- 3.9 The first mixer (see paragraph 2.7) consists of transformers L316, L317, diodes D312, D313, D314 and D315 and potentiometer P301.
- 3.10 In the 20 meter position of the bandswitch, oscillator voltage from the 18 Mhz oscillator is applied to the mixer from L318, mixing with the 14 Mhz signal frequency and producing an output frequency in the 3.5 Mhz to 4 Mhz frequency range.
- 3.11 In the 40 meter position of the bandswitch, oscillator voltage from the 11 Mhz oscillator is applied to the mixer from L318, mixing with the 7 Mhz signal frequency and producing an output frequency in the 3.5 Mhz to 4 Mhz frequency range.
- 3.12 In the 80 meter position of the bandswitch a positive voltage is applied through diode gate D316 and resistor R323 to the balanced mixer causing the mixer diodes to be forward biased thus allowing the stage to conduct straight through.
- 3.13 Output from the mixer is next fed via a coaxial cable to printed circuit board assembly PC101.
- 3.14 In the 20 meter position of the bandswitch (see paragraph 3.10.) crystal oscillator stage Q305 is activated by applying positive voltage to the stage from switch wafer W1, part of the bandswitch SW1.
- 3.15 In the 40 meter position of the bandswitch (see paragraph 3.11.) crystal oscillator stage Q306 is activated by applying a positive voltage to the stage from the switch wafer W1, part of the bandswitch SW1.
- 3.16 Transistor Q307 isolates and amplifies oscillator voltage from either of the crystal oscillator stages Q305 or Q306 and applies the output to the mixer through L317.
- 3.17 Output from the mixer transformer L317 is fed via a coaxial cable to the low pass filter section L101, L108, C101, C102, C103 and C104. This filter is designed to cut off just above 4 Mhz. Its purpose is to reduce local oscillator radiation and spurious and image responses in both the receive and transmit modes.
- 3.18 A double balanced mixer circuit consisting of transformers L102, L104 and diodes D101 through D104 mix the incoming 3.5 Mhz - 4 Mhz signal with the 5 Mhz - 5.5 Mhz VFO signal and produce a 9 Mhz intermediate frequency at the output.
- 3.19 Amplification of the IF frequency is accomplished by Q101 and then fed through diode gate D107 to the crystal filter FL101. In the receive condition D107 is turned on by the collector current flowing through it.
- 3.20 In the receive mode, diode switch D108 is turned OFF as is diode gate D109. However, D110 is turned ON shorting to ground signal from the IF amplifier IC101 which, in the transmit condition, is allowed to be fed to the mixer transformer L104.
- 3.21 Following the crystal filter FL101, an integrated circuit amplifier IC101, amplifies the signal to a level sufficient to drive the product detector Q102.
- 3.22 Product detector Q102 receives signal from the IF transformer L107 and oscillator voltage from the B Frequency Oscillator on printed circuit module PC201 and mixes the two together to produce a signal in the audio range.
- 3.23 Output from the product detector is applied to two audio amplifier stages simultaneously. Both amplifiers are contained in the same package but are operationally separate.
- 3.24 Operational amplifier (A) amplifies the signal and applies it to the audio gain control and thence to the integrated circuit audio output amplifier IC202 located on printed circuit module PC201.
- 3.25 Operational amplifier (B) amplifies and then applies the audio signal to AGC rectifiers D112 and D113 and to S Meter AGC Amplifier Q105.
- 3.26 Voltage doubler rectifier system D112 and D113 rectifies audio output from operational amplifier IC102 (B). A positive voltage supplied by voltage divider components R124 and R125 bias up the system so that rectification cannot take place until the signal level has reached a predetermined level thus preventing the AGC system from operating on weak signals.
- 3.27 In the receive condition D120 is reversed biased and thus not in operation.
- 3.28 DC voltage from rectifier D112 is proportional to signal level. This voltage is applied to the AGC DC amplifier Q104.
- 3.29 Capacitor C132 filters the output of the rectifier D112.
- 3.30 Resistor R126 prevents capacitor C131 from slowing the attack time of the AGC system yet allows the capacitor to charge as the signal continues and to

discharge when the signal ceases. The combination of components allow a fast attack, slow release AGC system.

- 3.31 DC amplifier Q104 applies the amplified AGC voltage to pin 5 of integrated circuit amplifier IC101 where considerable AGC control is effected.
- 3.32 S Meter/AGC amplifier Q105 applies amplified audio signal to two rectifier systems simultaneously. Diodes D118 and D119 rectify audio voltage and the signal is then applied to RF amplifier Q303 through control transistor Q304. (See paragraphs 3.7 and 3.8)
- 3.33 Output from Q105 is rectified by diode system D114 and D115 and then applied to the S Meter via limiting resistor R130.
- 3.34 Audio from operational amplifier IC102 (A) is fed via the receiver audio gain control to the integrated circuit audio amplifier IC202 where more than 3 watts of audio is produced. Feedback around the amplifier is applied through components C220, C221 and R232. Output from pin 1 is fed via an isolation capacitor C226 to the speaker.
- 3.35 Beat frequency oscillator voltage is developed in integrated circuit IC203. Two separate oscillators are contained within the one package. Either oscillator is actuated when the sideband selector switch is activated. Oscillation takes place when positive supply voltage is applied to the appropriate stage. Trimmer capacitors C227 and C233 allow the BFO crystals to be adjusted to frequency.
- 3.36 Within IC203 are two bipolar transistors, both of which act as emitter followers and allow the BFO oscillators to be isolated from the load.
- 3.37 Diode D208 is ON in the receive condition allowing BFO voltage to be applied to the product detector Q102.
- 3.38 Local oscillator voltage (VFO) is developed in the VFO module PC601. FET Q601 oscillates over the frequency range 5 Mhz to 5.5 Mhz. Tuning is accomplished with C7. A dial Set capacitor C6 allows the VFO Calibration to be adjusted. A trimmer capacitor C602 and the Inductor slug in L601 allow the VFO dial to be aligned and calibrated.
- 3.39 Output from Q601 is isolated and amplified by Q602 before being fed via coaxial cable to the mixer circuit on PC101.
- 3.40 Receiver incremental tuning (RIT) is accomplished by the action of diodes D601 and D602. When the RIT switch SW4, located on the front panel, is turned on the anode of diode D602 is grounded through R606 causing the diode to be OFF. At the same time diode D601 is turned ON and RIT capacitor C8 is connected across the VFO tuned circuit. In the OFF position of the RIT switch diode D602 is turned ON and D601 is turned OFF. This action causes RIT Capacitor C8 to disengage and C612 is connected in its place. Note that in the transmit condition, because the RIT Switch is connected to the Control Line, the RIT circuit is disconnected. See paragraph 3.42.
- 3.41 RF Gain Control P3 controls the gain of the RF stage Q303 by varying the emitter voltage and thus the current through the device.

## TRANSMIT CONDITION

- 3.42 When the microphone push-to-talk switch is pressed the relay RLY401 located on printed circuit module PC401 is closed. This relay performs the following functions:
  - a) Disconnects the antenna from the receiver and connects it to the transmitter linear amplifier output. Note that this action takes place after the low pass filters. (see paragraph 3.1)
  - b) Connects +13.6 volts to the transmitter linear amplifier module PC501 located on the heat sink at the rear of the chassis.
  - c) Connects +13.6 volts to the control line through filter components R401, L407, C405 and C406, located on PC401. The positive control line voltage is used to turn on or off various stages throughout the transceiver to enable the circuits to move from a receive to a transmit condition. When the push-to-talk switch is released the control line is grounded. (see paragraph 3.71)
- 3.43 Audio from the microphone is amplified by transistors Q201 and Q202 before being applied to the balanced modulator diodes D202 through D205. In the receive condition the amplifiers are disabled when the base of Q202 is grounded through D201 as the control line is grounded.
- 3.44 Capacitor C209 and potentiometer P201 allow precise adjustment of the carrier balance.
- 3.45 Carrier is generated in integrated circuit IC203. This portion of the circuit is explained in paragraphs 3.35, 3.36 and 3.37. Output from the stage is applied to the balanced modulator potentiometer P201.
- 3.46 Output from the balanced modulator (double sideband suppressed carrier), is fed via coaxial cable, diode D116 and TX Gate Q103 to the crystal filter FL101. Note that in the transmit mode, transistor Q101 is turned off by the application of a positive control line voltage to the emitter via diode D108 and resistor R106. When current ceases to flow through Q101 diode gate D107 opens.
- 3.47 Crystal filter FL101 removes the unwanted sideband from the double sideband signal and applies the output to integrated circuit amplifier IC101.
- 3.48 After amplification in IC101, signal is transmitted through L107, R135, C138, D109 and C106 to the primary of the mixer transformer L104. Diode D110 which had been closed in the receive mode has now been opened by the action of the Control Line.
- 3.49 The Mixer circuit, consisting of diodes D101 through D104, mixes 9 Mhz signal with the 5 Mhz - 5.5 Mhz VFO and produces a signal in the 3.5 Mhz to 4 Mhz range.
- 3.50 The VFO circuit has been described in paragraphs 3.38 - 3.40.
- 3.51 A low pass filter consisting of components L101, L108, C101, C102, C103 and C104 removes the unwanted image component and reduces VFO leakage before the signal is fed via coaxial cable to printed circuit module PC301.
- 3.52 Signal from the low pass filter on PC101 is fed to the next mixer stage consisting of diodes D312 through D315. The action of this stage together with the HF oscillators Q305, Q306 and amplifier Q307 have been described in paragraphs 3.9 through 3.12 and 3.14 through 3.17. However, it must be noted that the signal,

during the transmit mode, flows through the mixer in a direction opposite from the receive mode.

- 3.53 Output from the mixer transformer L316 bypasses Q303 (which has been turned OFF by the application of positive control line voltage to the emitter via D311 and R319) and is routed through diode gate D310. (which had been open in the receive mode.)
- 3.54 Signal from D310 is fed to one of three sets of tuned circuits which are diode switched by diodes D304 through D309. These circuits have been described in paragraphs 3.6 and 3.7.
- 3.55 Following the tuned circuits is diode T/R switch D302 which is OFF during the transmit mode and diode T/R switch D303 which is now ON, routing the transmit signal to the amplifier stages Q302 and Q301. Component value around these two stages have been carefully chosen to give equal gain across the three amateur bands.
- 3.56 Output from transistor linear amplifier Q301 is fed via coaxial cable to the input of the linear amplifier module PC501 located on the heat sink at the rear of the chassis. The amplifier consists of two class A stages, Q501 and Q502 driving a pair of pushpull transistors Q503 and Q504. Pushpull operation has been used in order to reduce the generation of 2nd harmonic components.
- 3.57 Capacitors C509 and C510 tune out the reactance of wideband transformer L504.
- 3.58 In a high power linear amplifier it is important that the bias supply be "stiff" and that the bias to the stage maintain a constant no-signal collector current. This is accomplished in the case of amplifier stage Q502 by using the regulation properties of a silver lead diode, D501. Not only does D501 maintain a constant bias voltage to the base of Q502 it also samples heat developed by the stage and lowers its resistance and consequently the bias to the stage, maintaining a constant collector current.
- 3.59 Bias to transistors Q503 and Q504 is maintained at a constant level by the action of diodes D502 and D503 and transistor amplifier Q505 in the manner outlined in the preceding paragraph. In this instance two diodes in series are required due to the voltage drop of the Q505 base emitter junction. It is very important that these diodes be replaced only with identical type diodes for the temperature characteristics of the diodes have been carefully chosen to track the amplifiers they regulate.
- 3.60 The output from the wideband transformer L504 is taken by coaxial cable to the relay RLY401 located on printed circuit board PC401.
- 3.61 From the relay the transmit signal is fed to the bandswitched low pass filters also located on PC401. (See paragraphs 3.1 and 3.2) The filters are instrumental in reducing harmonics developed in the transmitter linear amplifier output transistors Q503 and Q504.
- 3.62 Output from the bandswitch wafer W2 is connected by coaxial cable to the antenna socket S01.
- 3.63 Output at the antenna socket is supplied via C411 and R404 to ALC diode rectifiers D409 and D410. The level of the signal is varied by adjustment capacitor C412 located on PC401. The resultant control voltage is then fed to the base of Q104 where it is amplified and used to control the gain of integrated circuit IC101. Note that the action of this circuit is dependent upon proper matching of the transceiver to the antenna.

- 3.64 Output at the antenna socket is supplied via C409 to meter rectifiers D406 and D407. The level of the signal is varied by adjustment capacitor C408. The resultant DC voltage is fed directly to the meter via resistor R402. The meter will give a relative output reading only as voltage at the antenna socket will largely be determined by the antenna standing wave ratio and the voice characteristics of the transceiver operator.

#### CW TRANSMIT CONDITION

- 3.65 The ALDA 103 Transceiver uses a unique form of CW break-in. No operation of mode switches are required to transfer from SSB to CW operation. Both the CW key and the microphone may be left plugged in at all times. (Provided the microphone push-to-talk switch also opens the microphone circuit).
- 3.66 Refer to the PC401 schematic. The operation of this part of the circuit is as follows:  
CW Key Pressed. D404 ON. Relay closes. D403 reversed biased. D401 ON. C403 charges.  
The exciter is put into the transmit mode. C403 has been charged through D401 holding the relay closed between CW characters.
- 3.67 CW Key Released. D404 OPEN. D401 OPEN. D403 ON. Charge from C403 flows through D403 holding relay closed until C403 discharged. The capacitance value of C403 determines the length of time the transceiver will stay in the transmit condition after the CW key is released.
- 3.68 An 800 Hz tone oscillator IC201 located on PC201 supplies a very clean tone, via resistor R221 and the microphone gain control, to the transmit audio amplifier Q201. The tone oscillator is actuated only when the key is pressed. When the key is pressed the base of control transistor Q203 is made positive causing Q203 to saturate and supply positive voltage to the bridge T type oscillator IC201. Note that the microphone push-to-talk-switch cannot actuate the tone oscillator due to the presence of diode D404.
- 3.69 The tone level supplied to the transmit audio amplifier Q201 may be adjusted by the microphone gain control when in the CW mode.
- 3.70 A CW sidetone signal is made available to the receiver audio output amplifier and the level adjusted with the receiver audio gain control.
- #### 3.71 CONTROL CIRCUITS
- #### CONTROL CIRCUITS
- 3.71 Refer to paragraph 3.42. The relay RLY401 supplies a positive voltage to the CONTROL LINE during the transmit mode and a ground during the receive mode. The control line is indicated as such throughout the schematic diagrams. The control line is used to turn on appropriate stages in the transmit condition and turn off unwanted receiver circuits. Likewise, in the receive condition, the control line is used to deactivate unwanted transmit circuits.
- 3.72 Protection against power supply or battery polarity reversal is provided by protect diode D401 located on PC401. Only the currents to the exciter and receiver portions of the transceiver and the current to the relay coil of RLY401 are carried through the diode.
- 3.73 The transmit module PC401 does not receive its supply voltage through the polarity protect diode but the module is never-the-less protected because if the

microphone push-to-talk switch is pressed when the supply voltage is reversed, the relay will not energize, thus voltage is not able to get to the module.

#### ACCESSORIES: Noise Blanker.

- 3.74 The noise blanker input is received from the signal input to PC101. Received signals have been converted to the frequency range of 3.5 Mhz to 4.0 Mhz at this point.
- 3.75 Signal and noise pulses are applied to amplifier Q701 through C701. The input impedance of Q701 is high so that the device does not load the input to PC101. The noise and signals are further amplified by IC701.
- 3.76 Output from IC701 is coupled to the voltage doubler rectifier system through a very small capacitor C710 in an effort to discriminate against signals, and accept only the noise pulses.
- 3.77 Noise pulses are rectified by diodes D701 and D703 and then transmitted to pulse amplifiers Q702 and Q703 through diode gate D702.
- 3.78 Signal flowing through diode D703 also flows through resistor R711 causing a voltage drop. If the signal level is high or the noise is non pulse in nature a considerable voltage drop may be obtained across R711 which will cause diode gate D702 to be reverse biased preventing signal from reaching Q702. Noise pulses rising above the bias will continue to operate the pulse amplifiers. Without the automatic bias action of the circuit considerable cross modulation would result when the noise blanker is turned on.
- 3.79 The pulsed output from the pulse amplifier Q703 is fed to the base of the noise blanker switch Q106 which, when pulsed, puts a short across the output of the IF amplifier Q101 for the duration of the pulse.
- 3.80 Note: All noise blankers will at some time or other create some cross modulation which may only be eliminated by placing considerable selectivity ahead of the noise blanker circuit. Unfortunately, selectivity considerably widens the noise pulse making it necessary to silence the receive for longer periods which action in itself will cause interference.

## CHAPTER 4 ALIGNMENT AND ADJUSTMENT

- 4.1 VFO: Connect frequency counter to pin 4 of the PC101 printed circuit board connector. (Count from front of chassis).
- 4.2 Set Dial Set to center and turn RIT switch off.
- 4.3 Turn dial to read 0 and adjust the L601 coils slug until the frequency reads 5.00 Mhz.
- 4.4 Turn dial to 500 and adjust the trimmer capacitor C602 until the frequency counter reads 5.500 Mhz.
- 4.5 Repeat 4.3 and then 4.4. As one adjustment affects the other continue until the correct reading is obtained at both ends of the dial.
- 4.6 IF Alignment PC101: Connect a signal generator to the antenna input terminal. Set the bandswitch to the 80 meter band and the RF gain control fully advanced. Connect an audio voltmeter across the speaker.
- 4.7 Tune in a signal from the generator at about 3.8 Mhz keeping the signal generator output as low as possible with the signal just above the noise.

## ACCESSORIES: CRYSTAL CALIBRATOR

- 3.81 The crystal calibrator consists of a 1000kHz crystal oscillator followed by a  $\div 10$  divider, providing 100kHz marker signals, and a further  $\div 4$  divider providing 25kHz markers. Either the 100kHz or the 25kHz markers may be selected by appropriate positioning of the selector switch.
- 3.82 Integrated circuit IC801 comprises the 1000kHz crystal oscillator. Bias is provided by resistor R801. Frequency is accurately set by trimmer capacitor C803.
- 3.83 Output from crystal oscillator stage IC801 is applied to the input of the  $\div 10$  stage IC802, the 100kHz output of which is applied to the receiver antenna terminal through capacitor C807.
- 3.84 Output from the  $\div 10$  stage IC802 is applied to the input of the  $\div 4$  stage IC803, the 25kHz output of which is applied to the receiver antenna terminal through capacitor C808.
- 3.85 Switch SW1 applies +8.2 volts to IC801 and IC802 in the 100kHz position of the selector switch and to all three IC's in the 25kHz position of the selector switch. Note that in the 25kHz position, +8.2 volts is applied to IC801 and IC802 through the diode gate D801.
- 3.86 Adjustment. The capacitor C803 is used to adjust the crystal to exactly 100kHz. A frequency counter may be connected to the output of C807, and with the switch in the 100kHz position, the trimmer is adjusted for a 100kHz output. Alternately, the trimmer may be adjusted by beading the marker signals against WWV while listening in an adjacent receiver.
- 4.8 Adjust L105 and L107 for maximum output. No other adjustments are required on this printed circuit board.
- 4.9 RF Alignment PC301: Connect test equipment and set radio as indicated in paragraph 4.6 and 4.7.
- 4.10 Adjust the 80 meter coils L313, L314 and L315 for maximum output.
- 4.11 With the bandswitch set to the 40 Meter band and the signal generator and receiver dial set to 7.150 Mhz adjust the coils L310, L311 and L312 for maximum output.
- 4.12 With the bandswitch set to the 20 meter band and the signal generator and receiver dial set to 14.1 Mhz adjust the coils L306, L307 and L308 for maximum output.
- 4.13 Note: On the 80 meter and 40 Meter bands it may be necessary to readjust the coils L313, L314, L315 and L310, L311 and L312 during the transmit mode in order to obtain even transmitter output across the band. It will also be found that this adjustment will give even sensitivity across the two bands in the receive condition.
- 4.14 To adjust L310, L311 and L312 in the transmit condition connect the antenna output socket to a 50 ohm dummy load. Read the voltage across the dummy

load with a VTVM, oscilloscope or other sensitive meter. Plug in the CW key and with the key pressed adjust the microphone audio gain control until the transmitter is delivering  $\frac{1}{4}$  to  $\frac{1}{2}$  normal power. Approximately 25 to 40 volts RF.

- 4.15 Set the bandswitch to the 40 meter band and tune the dial across the band. *Slightly* adjust L310 to bring up the level at the low frequency end of the band and L312 to bring up the output at the high frequency end of the band the idea being to obtain equal output across the band.
- 4.16 To adjust the 80 meter coils repeat in the manner outlined in the last paragraph but using L313 and L315.
- 4.17 The 20 meter band should not require adjustment.
- 4.18 **Adjustment of Balanced Mixer Control P301:** Set up the test equipment and transceiver controls as given in paragraph 4.14.
- 4.19 Set the bandswitch to the 20 meter band.
- 4.20 Connect a sensitive receiver very lightly to the dummy load and tune to 18 Mhz, finding the output transmitted by the 18 Mhz crystal X301. Adjust P301 for minimum S meter reading on the coupled receiver. A more desirable method would be to connect radio and test equipment as indicated in paragraph 4.14. Observe the transmitter output while keyed *without* an input signal. Locate potentiometer P301 on PC301 board (third board in from meter side of set) and adjust for maximum null of the 18 Mhz component of the RF output signal.
- 4.21 **Adjustment of ALC:** Set the test equipment and the transceiver controls as given in paragraph 4.14.
- 4.22 Set the bandswitch to the 20 meter band and advance the microphone gain control while the CW key is pressed until the RF voltmeter or transceiver meter shows no further increase in output.
- 4.23 Adjust the ALC compression trimmer C412 located on PC401, nearest the rear, until the output just begins to drop. This adjustment is more accurately made using a two tone audio oscillator and oscilloscope connected to the output.

#### Adjustment of the Meter, TX Mode:

- 4.24 Set the test equipment and transceiver controls as given in paragraph 4.14.
- 4.25 Set the bandswitch to the 80 meter band and advance the microphone gain control while the CW key is pressed until the ALC prevents further increase in output.
- 4.26 Adjust the Meter Compression trimmer C408, located on PC401, nearest the front, until the meter reads full scale.

#### Adjusting the Carrier Balance Controls:

- 4.27 Set the test equipment and transceiver controls as given in paragraph 4.14.
- 4.28 Set the bandswitch to the 80 meter band. Turn down the microphone gain control and press the microphone push-to-talk switch.
- 4.29 Observe the transmitter output on a sensitive oscilloscope.
- 4.30 Adjust the carrier balance controls C209 and P201 located on PC201, one at a time for minimum. As one adjustment affects the other it is necessary to work back and forth between the two controls. It will be found advantageous to "anticipate" the control by adjusting a little beyond the minimum point. If adjusting the other

control adds carrier, the "anticipation" was in the wrong direction.

- 4.31 Important note: If it is necessary that the BFO/Carrier crystals be moved in frequency this adjustment should be made before the carrier balance adjustment is made.

#### Adjusting the BFO/Carrier Generator Crystal Frequencies:

- 4.32 Set the test equipment and the transceiver controls as given in paragraph 4.14.
- 4.33 Connect an audio signal generator to the microphone input jack and a VTVM across the dummy load.
- 4.34 Set the audio signal generator to 1000 Khz. It will now be necessary to key the transmitter by grounding the key line at the microphone jack.
- 4.35 Set the microphone audio gain control until 50 volts RMS is read on the VTVM.
- 4.36 Set the audio signal generator to 450 Hz and adjust the appropriate crystal trimmer C227 or C233, as determined by the setting of the sideband selector switch, until the output drops to 25 volts RMS.
- 4.37 Repeat the adjustment on the other sideband.
- 4.38 Important Note: After this setting is made the carrier balance adjustment should be checked. If the carrier has been thrown out of null it will have to be readjusted. See paragraphs 4.27-4.30.

#### Adjustment of the Tone Oscillator Control P202:

- 4.39 Set the test equipment and transceiver controls as given in paragraph 4.14.
- 4.40 With the CW key pressed adjust P202, located on PC201, until the oscillator stops as indicated when the sidetone stops. Now turn the control back until oscillator just operates and reliably starts while sending V's with the CW key. Do not go beyond this point or the waveform of the oscillator will be impaired.

#### Adjustment of Idle Bias for Transmit Power Amplifier:

- 4.41 Connect a 50 ohm dummy load to antenna socket.
- 4.42 Remove the two top screws at both ends of the PA Heat Sink and loosen the two bottom screws. Gradually rotate the Heat Sink Assembly away from the back of the chassis. Preset Bias POT P501 to the full clockwise stop.
- 4.43 Unsolder the inner coax lead on the terminal strip located near the 2N3866 transistor. Now unsolder the outside end of the PA Choke L508. This is the coil wound around the 10 ohm 2 watt Resistor. Connect a 150 MA meter in series with the lead from L508 and its original terminating point.
- 4.44 Key the transceiver with the microphone PTT switch. Rotate PA Bias Pot P501 counterclockwise for 85 MA. Idle bias current. Unkey transceiver.
- 4.45 Remove meter. Resolder L508 to original termination and coax inner lead to terminal strip. Close Heat Sink Assembly to original position and install two top screws and tighten all four screws.

PC101

	DC		AC		NOTES
	RX	TX	RX	TX	
TP1	-	-	.5V P-P	.5V P-P	
TP2				.3V P-P	Loud Whistle Mic Gain Full CW
TP3	+6.4	+7.0		.1V P-P	Loud Whistle Mic Gain Full CW
TP4	+6.8	+6.9	*.05V P-P	† 4V P-P	* ~ 5mv Input Signal Loud Whistle Mic Gain † Full CW
TP5	+5.8	+5.8	.01V P-P	-	~ 5mv Input Signal
TP6	+3.7	0	1V P-P	-	~ 5mv Input Signal
TP7	+3.7	0	.75V P-P	-	~ 5mv Input Signal
TP8	+3.3 * +3.5 †	+2.9	-	-	* No Signal † 5mv Input Signal
TP9	+2.1 * +2.5 †	+2.1	-	-	* No Signal † 5mv Input Signal
TP10	+5.9	+5.9	*† 2.5V P-P	-	* 5mv Input Signal
TP11	0	+ .75	-	.6V P-P	Loud Whistle Mic Gain Full CW

NOTE: Ensure Supply Voltage to TX linear amplifier is disconnected while measurements are taken. Refer to NOTE 1 under voltage measurements.

PC201

	DC		AC		NOTES
	RX	TX	RX	TX	
TP1	+1.7	+4	-	2V P-P	Loud Whistle Mic Gain Full CW
TP2	+0.6	+3.4V	-	2V P-P	Loud Whistle Mic Gain Full CW
TP3	~ +3.4	~ +3.4	~ 10V P-P	~ 10V P-P	SB SW Activated
TP4	~ +3.4	~ +3.4	~ 10V P-P	~ 10V P-P	SB SW Activated
TP5	~ +3.2	~ +3.2	~ 7V P-P	~ 7V P-P	
TP6	~ +3.2	~ +3.2	~ 4V P-P	~ 4V P-P	
TP7	~ +3.0	~ +3.0	~ 1.5V P-P	~ 1.5V P-P	
TP8	-	* 0 † + 12.2V	-	-	† CW Key Up † CW Key Down
TP9	-	* + 0.25 † + 6.4V	-	* - † 10V P-P	* CW Key Up † CW Key Down
TP10	+6.2	+6.2	6.4V P-P	-	Max Signal (Clipping)

NOTE: Ensure Supply Voltage to TX linear amplifier module is disconnected while measurements are taken. Refer to NOTE 1 under Voltage measurements.

PC301

	DC		AC		NOTES
	RX	TX	RX	TX	
TP1	+ .6V	+ .6V	2V P-P	2V P-P	20 Meter B-SW Position
TP2	+ .65V	+ .65V	2.5V P-P	2.5V P-P	40 Meter B-SW Position
TP3	+ 4.2	+ 4.2	.4V P-P	.4V P-P	20, 40 Meter B-SW Position
TP4	+ 3.2	+ 4	—	—	RF Gain Full CW
TP5	+ 7.4	+ 7.8	—	—	
TP6	+ .5V	+ 1V	—	—	
TP7	+ .5V	+ 4.8V	—	.05 P-P	40 Meter Band
TP8	+ .5	+ 11.8V	—	1.5V P-P	40 Meter Band
TP9	—	—	—	.8V P-P	40 Meter Band

NOTE: Ensure Supply Voltage to TX linear amplifier module is disconnected while measurements are taken. Refer to NOTE 1 under Voltage Measurements.

PC501 (TX LINEAR AMP MODULE)

		DC		AC	
Q501	E	+ .6V		* —	* Mic Gain Full CW Loud Whistle, 7MHZ
	B	+ 1.3V		0.6V P-P	
	C	+ 11V		6V P-P	
Q502	B	+ .7		* 2V P-P	* Mic Gain Full CW Loud Whistle, 7MHZ
	C	+ 13.6V		20V P-P	
Q503	B	+ .62		* 7V P-P	* Mic Gain Full CW Loud Whistle, 7MHZ
Q504	C	+ 13.6		40V P-P	
Q505	E	+ .64		—	
	B	+ 1.2			
	C	+ 13.6			

PC601 (VFO)

		DC		AC	
Fixed Plates C1		—		12V P-P	
Q601	S	+ 1.5		6V P-P	
	D	+ 6.2V		—	
Q602	B	+ .7V		.02V P-P	
	C	+ 7V		2.5V P-P	
Junction L604 & C611		—		.6V P-P	

VOLTAGE CHARTS

Note 1: When making low level oscilloscope measurements, when in the transmit condition, the supply voltage to the TX Linear Amplifier Module PC501 must be disconnected to prevent pickup on the oscilloscope probe from the high level amplifier output. This is accomplished by first loosening the two bottom screws at both ends of the PA Heat Sink. Secondly, remove the two top screws at both ends of the PA Heat Sink. Then gradually rotate the Heat Sink Assembly away from the back of the chassis. Now unsolder the outside end of the PA choke L508. This is the coil wound around the

10 ohm 2 watt Resistor.

Note 2: As few amateurs will have two tone oscillators suitable for accurate measurements, the voltage charts have been prepared using a prolonged whistle into the microphone with the microphone audio gain control fully advanced.

Note 3: When measuring the audio voltage at test point 10 on PC201, the receiver audio gain control and RF gain control should be fully advanced so that the signal at test point 10 fully clipped. The signal should be clipped equally on both sides. If clipping occurs on one side only, it may indicate a defective IC202.



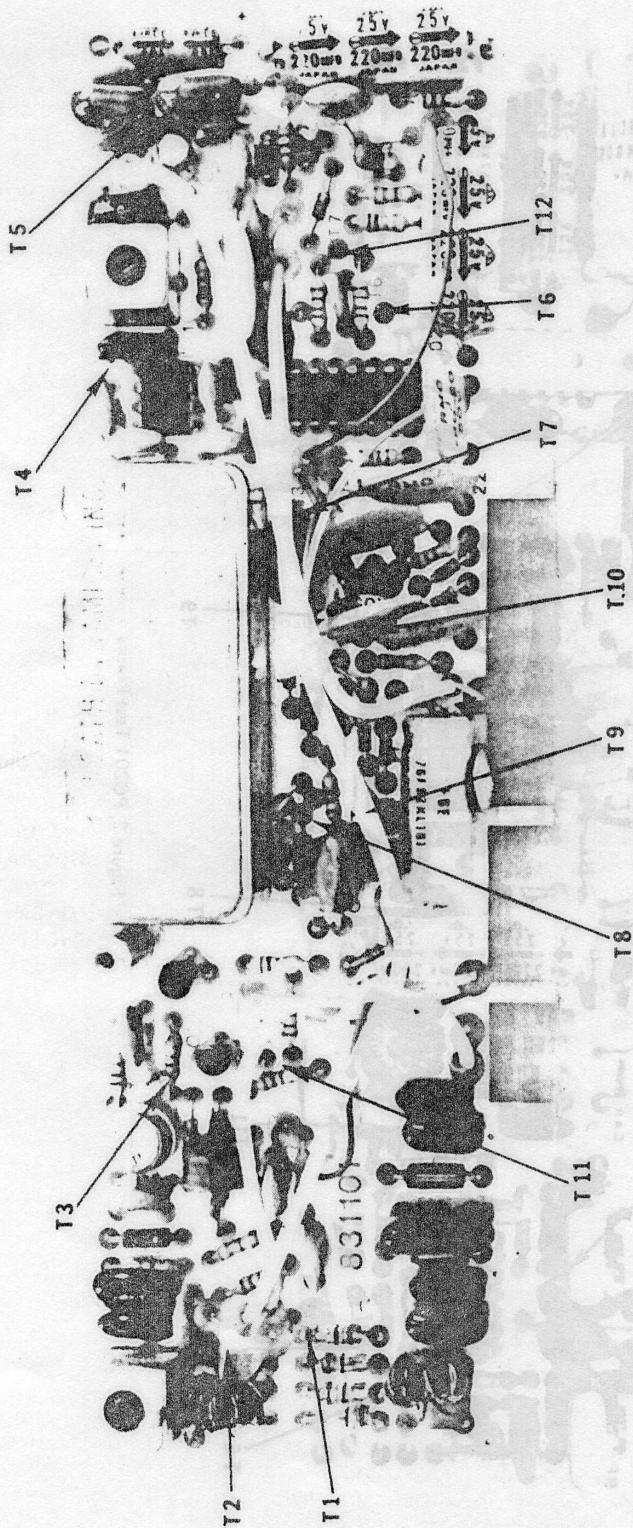

Figure 1, PC101 Test Points

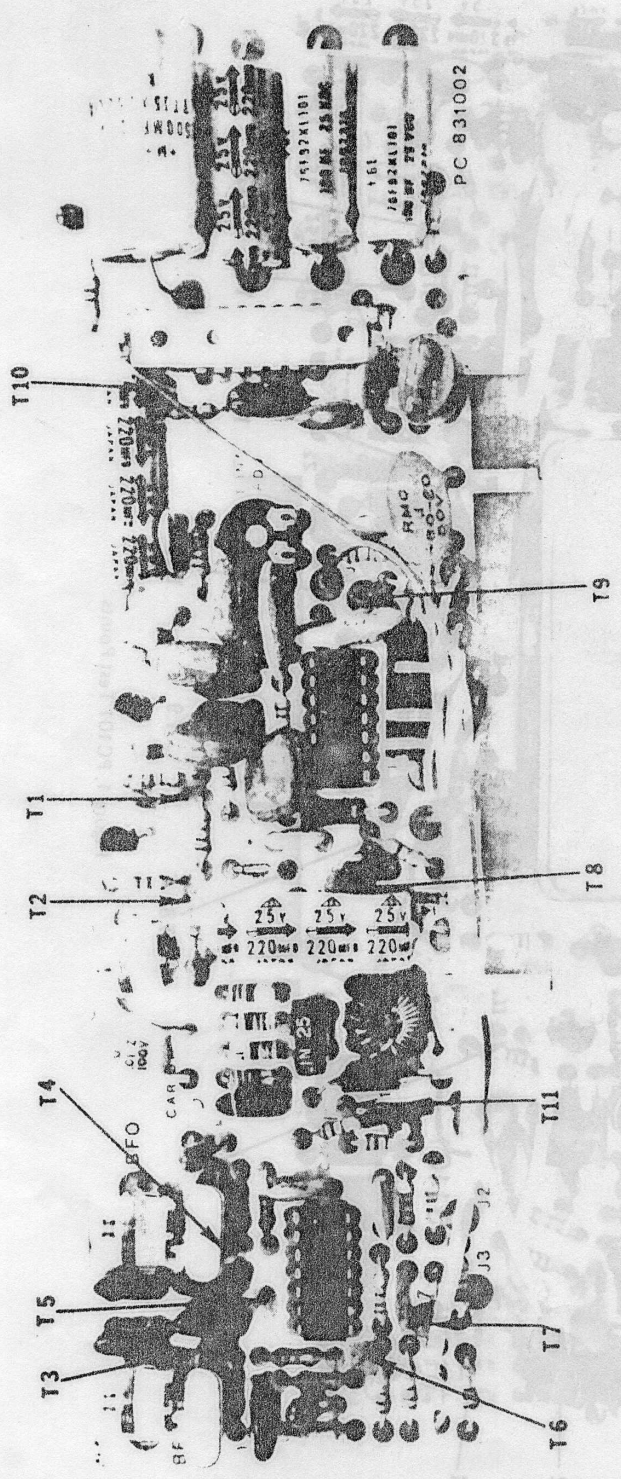

Figure 2, PC201 Test Points

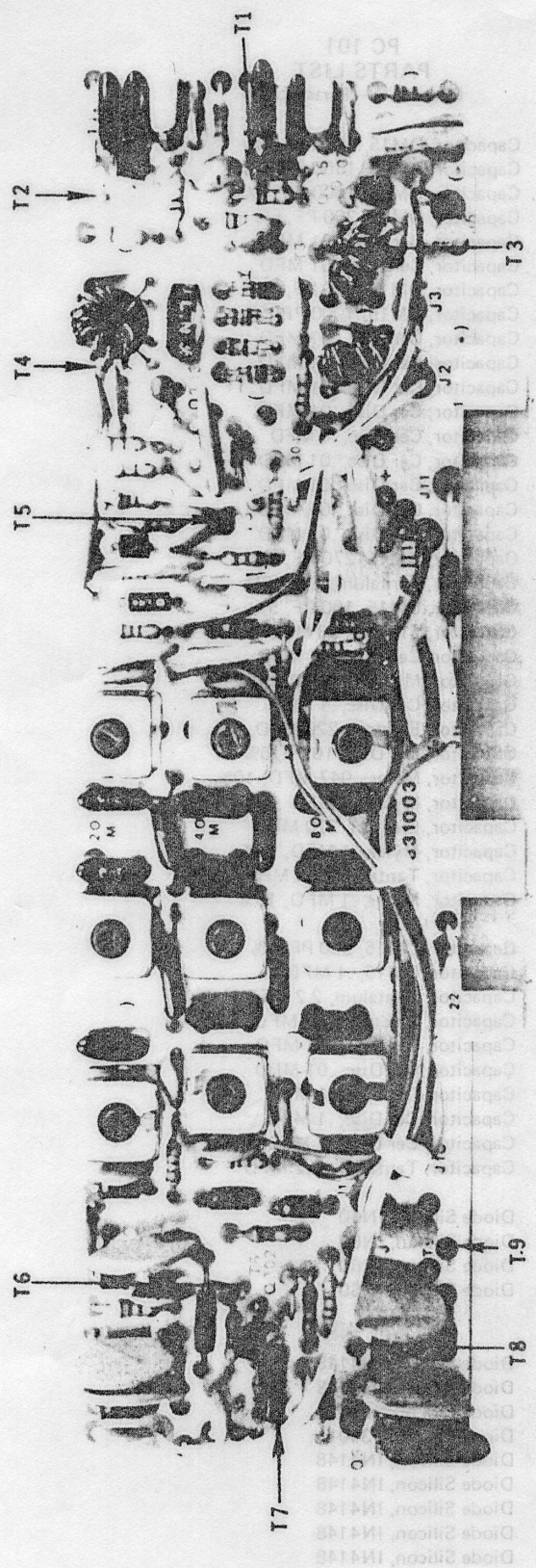

Figure 3, PC301 Test Points

41000	D118
41000	D117
41000	D113
41000	D112
41000	D110
41000	D109
41000	D108
41000	D107
Not Assigned	D106
Not Assigned	D105
41003	D104
41003	D103
41003	D102
41003	D101
15000	C143
11003	C141
11003	C140
11003	C139
11003	C138
14003	C137
18000	C136
11003	C135
11003	C134
18500	C133
18000	C132
18000	C130
18000	C129
18000	C128
18500	C127
18500	C126
18500	C125
18500	C124
18500	C123
18500	C122
18001	C121
15000	C120
15000	C119
15000	C118
15000	C117
15000	C116
15003	C115
15003	C114
15003	C113
15003	C112
15003	C111
15003	C110
15003	C109
15003	C108
15003	C107
15003	C106
15003	C105
15003	C104
15003	C103
15003	C102
15003	C101
15003	C100
15003	C099
15003	C098
15003	C097
15003	C096
15003	C095
15003	C094
15003	C093
15003	C092
15003	C091
15003	C090
15003	C089
15003	C088
15003	C087
15003	C086
15003	C085
15003	C084
15003	C083
15003	C082
15003	C081
15003	C080
15003	C079
15003	C078
15003	C077
15003	C076
15003	C075
15003	C074
15003	C073
15003	C072
15003	C071
15003	C070
15003	C069
15003	C068
15003	C067
15003	C066
15003	C065
15003	C064
15003	C063
15003	C062
15003	C061
15003	C060
15003	C059
15003	C058
15003	C057
15003	C056
15003	C055
15003	C054
15003	C053
15003	C052
15003	C051
15003	C050
15003	C049
15003	C048
15003	C047
15003	C046
15003	C045
15003	C044
15003	C043
15003	C042
15003	C041
15003	C040
15003	C039
15003	C038
15003	C037
15003	C036
15003	C035
15003	C034
15003	C033
15003	C032
15003	C031
15003	C030
15003	C029
15003	C028
15003	C027
15003	C026
15003	C025
15003	C024
15003	C023
15003	C022
15003	C021
15003	C020
15003	C019
15003	C018
15003	C017
15003	C016
15003	C015
15003	C014
15003	C013
15003	C012
15003	C011
15003	C010
15003	C009
15003	C008
15003	C007
15003	C006
15003	C005
15003	C004
15003	C003
15003	C002
15003	C001
15003	C000

PC 101  
PARTS LIST  
Chapter 6 - Parts Lists

	P/N		
C101	125102	Capacitor, DM15, 1000 PF, 5%	500V
C102	135152	Capacitor, DM19, 1500 PF, 5%	500V
C103	125102	Capacitor, DM19, 1000 PF, 5%	500V
C104	125201	Capacitor, DM19, 200 PF, 5%	500V
C105	110012	Capacitor, Cer Disc, .01 MFD	50V
C106	110012	Capacitor, Cer Disc, .01 MFD	50V
C107	125331	Capacitor, DM15, 330 PF, 5%	500V
C108	125102	Capacitor, DM15, 1000 PF, 5%	500V
C109	110012	Capacitor, Cer Disc, .01 MFD	50V
C110	110012	Capacitor, Cer Disc, .01 MFD	50V
C111	110012	Capacitor, Cer Disc, .01 MFD	50V
C112	110012	Capacitor, Cer Disc, .01 MFD	50V
C113	110023	Capacitor, Cer Disc, .1 MFD	50V
C114	110012	Capacitor, Cer Disc, .01 MFD	50V
C115	110012	Capacitor, Cer Disc, .01 MFD	50V
C116	110012	Capacitor, Cer Disc, .01 MFD	50V
C117	110012	Capacitor, Cer Disc, .01 MFD	50V
C118	125271	Capacitor, DM15, 270 PF, 5%	500V
C119	150000	Capacitor, Tantalum, 2.2 MFD	25V
C120	125101	Capacitor, DM15, 100 PF, 5%	500V
C121	140001	Capacitor, Electrol, 33 MFD	16V
C122	110012	Capacitor, Cer Disc, .01 MFD	50V
C123	182004	Capacitor, Mylar, .1 MFD, 10%	50V
C124	110023	Capacitor, Cer Disc, .1 MFD	50V
C125	140005	Capacitor, Electrol, 220 MFD, 5%	25V
C126	115001	Capacitor, Cer Disc, 10 PF, 5%	50V
C127	182003	Capacitor, Mylar, .047 MFD, 10%	50V
C128	182004	Capacitor, Mylar, .1 MFD	50V
C129	140005	Capacitor, Electrol, 220 MFD	25V
C130	182004	Capacitor, Mylar, .1 MFD, 10%	50V
C131	150000	Capacitor, Tantalum, 2.2 MFD	25V
C132	182004	Capacitor, Mylar, .1 MFD, 10%	50V
C133	Not Assigned		
C134	125361	Capacitor, DM15, 360 PF, 5%	
C135	110023	Capacitor, DM15, .1 MFD	50V
C136	150000	Capacitor, Tantalum, 2.2 MFD	25V
C137	140003	Capacitor, Electrol, 100 MFD	25V
C138	110012	Capacitor, Cer Disc, .01 MFD	50V
C139	110012	Capacitor, Cer Disc, .01 MFD	50V
C140	110023	Capacitor, Cer Disc, .1 MFD	50V
C141	110023	Capacitor, Cer Disc, .1 MFD	50V
C142	110023	Capacitor, Cer Disc, .1 MFD	50V
C143	150000	Capacitor, Tantalum, 2.2 MFD	25V
D101	410003	Diode Silicon, IN60	
D102	410003	Diode Silicon, IN60	
D103	410003	Diode Silicon, IN60	
D104	410003	Diode Silicon, IN60	
D105	Not Assigned		
D106	Not Assigned		
D107	410000	Diode Silicon, IN4148	
D108	410000	Diode Silicon, IN4148	
D109	410002	Diode Pin, MPN3401	
D110	410002	Diode Pin, MPN3401	
D111	410000	Diode Silicon, IN4148	
D112	410000	Diode Silicon, IN4148	
D113	410000	Diode Silicon, IN4148	
D114	410000	Diode Silicon, IN4148	
D115	410000	Diode Silicon, IN4148	

D116	410000	Diode Silicon, IN4148	
D117	Not Assigned		
D118	410000	Diode Silicon, IN4148	
D119	410000	Diode Silicon, IN4148	
D120	410000	Diode Silicon, IN4148	
IC101	460000	Integrated Circuit, MC1350P	
IC102	460002	Integrated Circuit, LM3900A	
Q101	440000	Transistor, Silicon, 2N3866	
Q102	450000	Transistor, FET, 40673	
Q103	440001	Transistor, Silicon, MPS6514	
Q104	440010	Transistor, Silicon, MPSA14	
Q105	440001	Transistor, Silicon, MPS6514	
Q106	440001	Transistor, Silicon, MPS6514	
L101	330113	Inductor, RFC, 2.2 $\mu$ h	
L102	A330100	Inductor, Toroidal	
L103	Not Assigned		
L104	A330100	Inductor, Toroidal	
L105	A330104	Transformer, IF	
L106	330111	Inductor, RFC, 180 $\mu$ h	
L107	A330104	Transformer, IF	
L108	330113	Inductor, RFC, 2.2 $\mu$ h	
FL101	B952100	Crystal Filter, 9 MHZ	
PC101	831101	Printed Circuit Board	
R101	Not Assigned	Resistor, Comp	
R102	215101	Resistor, Comp, 100 $\Omega$ , 1/4 W, 5%	
R103	215103	Resistor, Comp, 10 K, 1/4 W, 5%	
R104	215102	Resistor, Comp, 1 K, 1/4 W, 5%	
R105	Not Assigned		
R106	215221	Resistor, Comp, 220 $\Omega$ , 1/4 W, 5%	
R107	215332	Resistor, Comp, 3.3 K, 1/4 W, 5%	
R108	215332	Resistor, Comp, 3.3 K, 1/4 W, 5%	
R109	215101	Resistor, Comp, 100 $\Omega$ , 1/4 W, 5%	
R110	215100	Resistor, Comp, 10 $\Omega$ , 1/4 W, 5%	
R111	215271	Resistor, Comp, 270 $\Omega$ , 1/4 W, 5%	
R112	215102	Resistor, Comp, 1 K, 1/4 W, 5%	
R113	215101	Resistor, Comp, 100 $\Omega$ , 1/4 W, 5%	
R114	215222	Resistor, Comp, 2.2 K, 1/4 W, 5%	
R115	215101	Resistor, Comp, 100 $\Omega$ , 1/4 W, 5%	
R116	215102	Resistor, Comp, 1 K, 1/4 W, 5%	
R117	215221	Resistor, Comp, 220 $\Omega$ , 1/4 W, 5%	
R118	215103	Resistor, Comp, 10 K, 1/4 W, 5%	
R119	215205	Resistor, Comp, 2 MEG, 1/4 W, 5%	
R120	215105	Resistor, Comp, 1 MEG, 1/4 W, 5%	
R121	215105	Resistor, Comp, 1 MEG, 1/4 W, 5%	
R122	215332	Resistor, Comp, 3.3 K, 1/4 W, 5%	
R123	215205	Resistor, Comp, 2 MEG, 1/4 W, 5%	
R124	215331	Resistor, Comp, 330 $\Omega$ , 1/4 W, 5%	
R125	215471	Resistor, Comp, 470 $\Omega$ , 1/4 W, 5%	
R126	215222	Resistor, Comp, 2.2 K, 1/4 W, 5%	
R127	215106	Resistor, Comp, 10 MEG, 1/4 W, 5%	
R128	215682	Resistor, Comp, 6.8 K, 1/4 W, 5%	
R129	215104	Resistor, Comp, 100 K, 1/4 W, 5%	
R130	215682	Resistor, Comp, 6.8 K, 1/4 W, 5%	
R131	215471	Resistor, Comp, 470 $\Omega$ , 1/4 W, 5%	
R132	215683	Resistor, Comp, 68 K, 1/4 W, 5%	
R133	215101	Resistor, Comp, 100 $\Omega$ , 1/4 W, 5%	
R134	215103	Resistor, Comp, 10 K, 1/4 W, 5%	

R135	215101	Resistor, Comp, 100 $\Omega$ , 1/4 W, 5%	410001	0110
R136	215102	Resistor, Comp, 1 K, 1/4 W, 5%	410002	0111
R137	215102	Resistor, Comp, 1 K, 1/4 W, 5%	410002	0118
R138	215102	Resistor, Comp, 1 K, 1/4 W, 5%	410002	0119
R139	215221	Resistor, Comp, 220 $\Omega$ , 1/4 W, 5%	410003	0120
R140	215682	Resistor, Comp, 6.8 K, 1/4 W, 5%	410004	0121
R141	Not Assigned		410005	0122
R142	215224	Resistor, Comp, 220 K, 1/4 W, 5%	410006	0123
R143	215473	Resistor, Comp, 47 K, 1/4 W, 5%	410007	0124

QTY				
1	812405	Stand Off, Hex, 0.812 x 1/4 x 4/40	440001	0103
11	600000	Header Pin (Test Points)	440010	0104

PC201  
PARTS LIST

	P/N			
C201	110012	Capacitor, Cer Disc, .01 MFD	470010	50V
C202	150000	Capacitor, Tantalum, 2.2 MFD	470011	25V
C203	110012	Capacitor, Cer Disc, .01 MFD	470012	50V
C204	140005	Capacitor, Electrol, 220 MFD	470013	25V
C205	110012	Capacitor, Cer Disc, .01 MFD	470014	50V
C206	150000	Capacitor, Tantalum, 2.2 MFD	470015	25V
C207	110012	Capacitor, Cer Disc, .01 MFD	470016	50V
C208	125390	Capacitor, DM15, 39 PF, 5%	470017	500V
C209	162001	Capacitor, Trim, 3.5-65 PF	470018	50V
C210	110012	Capacitor, Cer Disc, .01 MFD	470019	50V
C211	182004	Capacitor, Mylar, .1 MFD, 10%	470020	50V
C212	182004	Capacitor, Mylar, .1 MFD, 10%	470021	50V
C213	182004	Capacitor, Mylar, .1 MFD, 10%	470022	50V
C214	182004	Capacitor, Mylar, .1 MFD, 10%	470023	50V
C215	110023	Capacitor, Cer Disc, .1 MFD	470024	50V
C216	110023	Capacitor, Cer Disc, .1 MFD	470025	50V
C217	140009	Capacitor, Electrol, 1500 MFD	470026	25V
C218	110012	Capacitor, Cer Disc, .01 MFD	470027	50V
C219	182004	Capacitor, Mylar, .1 MFD, 10%	470028	50V
C220	182003	Capacitor, Mylar, .047 MFD, 10%	470029	50V
C221	125102	Capacitor, DM15, 1000 PF, 5%	470030	500V
C222	140003	Capacitor, Electrol, 100 MFD	470031	25V
C223	140003	Capacitor, Electrol, 100 MFD	470032	25V
C224	150000	Capacitor, Tantalum, 2.2 MFD	470033	25V
C225	140005	Capacitor, Electrol, 220 MFD	470034	25V
C226	140005	Capacitor, Electrol, 220 MFD	470035	25V
C227	162001	Capacitor, Trim, 3.5-65 PF	470036	500V
C228	125101	Capacitor, DM15, 100 PF, 5%	470037	500V
C229	150000	Capacitor, Tantalum, 2.2 MFD	470038	25V
C230	150000	Capacitor, Tantalum, 2.2 MFD	470039	25V
C231	125101	Capacitor, DM15, 100 PF, 5%	470040	500V
C232	125101	Capacitor, DM15, 100 PF, 5%	470041	500V
C233	162001	Capacitor, Trim, 3.5-65 PF	470042	50V
C234	110012	Capacitor, Cer Disc, .01 MFD	470043	50V
C235	110012	Capacitor, Cer Disc, .01 MFD	470044	50V
C236	110012	Capacitor, Cer Disc, .01 MFD	470045	50V
C237	110012	Capacitor, Cer Disc, .01 MFD	470046	50V
C238	110012	Capacitor, Cer Disc, .01 MFD	470047	50V
C239	110023	Capacitor, Cer Disc, .1 MFD	470048	50V
C240	125390	Capacitor, DM15, 39 PF, 5%	470049	500V
C241	125390	Capacitor, DM15, 39 PF, 5%	470050	500V

D201	410000	Diode, Silicon, IN4148	
D202	410003	Diode, Silicon, IN60	
D203	410003	Diode, Silicon, IN60	
D204	410003	Diode, Silicon, IN60	
D205	410003	Diode, Silicon, IN60	
D206	430001	Diode, Zener, IN5344B, 5 W	8.2V
D207	410000	Diode, Silicon, IN4148	
D208	410000	Diode, Silicon, IN4148	
IC201	460002	Integrated Circuit, LM3900A	
IC202	460001	Integrated Circuit, UA706	
IC203	460003	Integrated Circuit, CA3086	
Q201	440001	Transistor, Silicon, MPS6514	
Q202	440001	Transistor, Silicon, MPS6514	
Q203	440008	Transistor, Silicon, 2N3638	
P201	260006	Potentiometer, 100 $\Omega$	
P202	260005	Potentiometer, 2.5 K	
L201	330114	Inductor, RFC, 15 $\mu$ h	
L202	A330109	Transformer, Toroidal	
X201	A951008	Crystal, 9001.5 KHZ	
X202	A951009	Crystal, 8998.5 KHZ	
PC201	831102	Printed Circuit Board	
R201	215102	Resistor, Comp, 1 K, 1/4 W, 5%	
R202	215102	Resistor, Comp, 1 K, 1/4 W, 5%	
R203	215101	Resistor, Comp, 100 $\Omega$ , 1/4 W, 5%	
R204	215101	Resistor, Comp, 100 $\Omega$ , 1/4 W, 5%	
R205	215471	Resistor, Comp, 470 $\Omega$ , 1/4 W, 5%	
R206	215101	Resistor, Comp, 100 $\Omega$ , 1/4 W, 5%	
R207	215333	Resistor, Comp, 33 K, 1/4 W, 5%	
R208	215333	Resistor, Comp, 33 K, 1/4 W, 5%	
R209	215681	Resistor, Comp, 680 $\Omega$ , 1/4 W, 5%	
R210	215101	Resistor, Comp, 100 $\Omega$ , 1/4 W, 5%	
R211	215333	Resistor, Comp, 33 K, 1/4 W, 5%	
R212	215333	Resistor, Comp, 33 K, 1/4 W, 5%	
R213	215101	Resistor, Comp, 100 $\Omega$ , 1/4 W, 5%	
R214	215102	Resistor, Comp, 100 $\Omega$ , 1/4 W, 5%	
R215	215101	Resistor, Comp, 100 $\Omega$ , 1/4 W, 5%	
R216	215101	Resistor, Comp, 100 $\Omega$ , 1/4 W, 5%	
R217	215221	Resistor, Comp, 220 $\Omega$ , 1/4 W, 5%	
R218	215102	Resistor, Comp, 1 K, 1/4 W, 5%	
R219	215102	Resistor, Comp, 1 K, 1/4 W, 5%	
R220	215223	Resistor, Comp, 22 K, 1/4 W, 5%	
R221	215105	Resistor, Comp, 1 MEG, 1/4 W, 5%	
R222	215103	Resistor, Comp, 10 K, 1/4 W, 5%	
R223	215473	Resistor, Comp, 47 K, 1/4 W, 5%	
R224	215205	Resistor, Comp, 2 MEG, 1/4 W, 5%	
R225	215105	Resistor, Comp, 1 MEG, 1/4 W, 5%	
R226	215182	Resistor, Comp, 1.8 K, 1/4 W, 5%	
R227	215182	Resistor, Comp, 1.8 K, 1/4 W, 5%	
R228	245330	Resistor, Comp, 33 $\Omega$ , 2 W, 5%	
R229	215473	Resistor, Comp, 47 K, 1/4 W, 5%	
R230	215471	Resistor, Comp, 470 $\Omega$ , 1/4 W, 5%	
R231	215470	Resistor, Comp, 47 $\Omega$ , 1/4 W, 5%	
R232	215470	Resistor, Comp, 47 $\Omega$ , 1/4 W, 5%	
R233	215224	Resistor, Comp, 220 K, 1/4 W, 5%	
QTY			
11	600000	Header Pins (Test Points)	

PC301  
PARTS LIST

	P/N		
C301	110012	Capacitor, Cer Disc, .01 MFD	50V
C302	110023	Capacitor, Cer Disc, .1 MFD	50V
C303	110023	Capacitor, Cer Disc, .1 MFD	50V
C304	135222	Capacitor, DM19, 2200 PF, 5%	500V
C305	125470	Capacitor, DM15, 47 PF, 5%	500V
C306	182006	Capacitor, Mylar, .01 MFD, 10%	50V
C307	110012	Capacitor, Cer Disc, .01 MFD	50V
C308	110012	Capacitor, Cer Disc, .01 MFD	50V
C309	110012	Capacitor, Cer Disc, .01 MFD	50V
C310	110012	Capacitor, Cer Disc, .01 MFD	50V
C311	110012	Capacitor, Cer Disc, .01 MFD	50V
C312	125111	Capacitor, DM15, 110 PF, 5%	500V
C313	125101	Capacitor, DM15, 100 PF, 5%	500V
C314	125101	Capacitor, DM15, 100 PF, 5%	500V
C315	110012	Capacitor, Cer Disc, .01 MFD	50V
C316	110023	Capacitor, Cer Disc, .1 MFD	50V
C317	110012	Capacitor, Cer Disc, .01 MFD	50V
C318	110012	Capacitor, Cer Disc, .01 MFD	50V
C319	125471	Capacitor, DM15, 470 PF, 5%	500V
C320	125471	Capacitor, DM15, 470 PF, 5%	500V
C321	125471	Capacitor, DM15, 470 PF, 5%	500V
C322	110012	Capacitor, Cer Disc, .01 MFD	50V
C323	110023	Capacitor, Cer Disc, .1 MFD	50V
C324	110023	Capacitor, Cer Disc, .1 MFD	50V
C325	125471	Capacitor, DM15, 470 PF, 5%	500V
C326	125201	Capacitor, DM15, 200 PF, 5%	500V
C327	125201	Capacitor, DM15, 200 PF, 5%	500V
C328	125201	Capacitor, DM15, 200 PF, 5%	500V
C329	110012	Capacitor, Cer Disc, .01 MFD	50V
C330	110023	Capacitor, Cer Disc, .1 MFD	50V
C331	110023	Capacitor, Cer Disc, .1 MFD	50V
C332	110023	Capacitor, Cer Disc, .1 MFD	50V
C333	110012	Capacitor, Cer Disc, .01 MFD	50V
C334	110012	Capacitor, Cer Disc, .01 MFD	50V
C335	110023	Capacitor, Cer Disc, .1 MFD	50V
C336	110023	Capacitor, Cer Disc, .1 MFD	50V
C337	110023	Capacitor, Cer Disc, .1 MFD	50V
C338	110012	Capacitor, Cer Disc, .01 MFD	50V
C339	110023	Capacitor, Cer Disc, .1 MFD	50V
C340	110012	Capacitor, Cer Disc, .01 MFD	50V
C341	110012	Capacitor, Cer Disc, .01 MFD	50V
C342	110012	Capacitor, Cer Disc, .01 MFD	50V
C343	150000	Capacitor, Tantalum, 2.2 MFD	25V
C344	110023	Capacitor, Cer Disc, .1 MFD	50V
C345	110012	Capacitor, Cer Disc, .01 MFD	50V
C346	110012	Capacitor, Cer Disc, .01 MFD	50V
C347	115000	Capacitor, Cer Disc, 1 PF, 5%	1000V
C348	115000	Capacitor, Cer Disc, 1 PF, 5%	1000V
C349	125470	Capacitor, DM15, 47 PF, 5%	500V
C350	125470	Capacitor, DM15, 47 PF, 5%	500V
C351	125470	Capacitor, DM15, 47 PF, 5%	500V
C352	125470	Capacitor, DM15, 47 PF, 5%	500V
C353	125470	Capacitor, DM15, 47 PF, 5%	500V
C354	125470	Capacitor, DM15, 47 PF, 5%	500V
C355	125390	Capacitor, DM15, 39 PF, 5%	500V
C356	125390	Capacitor, DM15, 39 PF, 5%	500V
C357	150000	Capacitor, Tantalum, 2.2 MFD	25V
C358	110023	Capacitor, Cer Disc, .1 MFD	50V
C359	110012	Capacitor, Cer Disc, .01 MFD	50V



C360	110023	Capacitor, Cer Disc, .1 MFD	50V
C361	110012	Capacitor, Cer Disc, .01 MFD	50V
C362	110023	Capacitor, Cer Disc, .1 MFD	50V
C363	125050	Capacitor, DM15, 5 PF	
C364	125050	Capacitor, DM15, 5 PF	
D301	420002	Diode, Silicon, IN4001	
D302	420002	Diode, Silicon, IN4001	
D303	410002	Diode, Pin, MPN3401	
D304	420002	Diode, Silicon, IN4001	
D305	420002	Diode, Silicon, IN4001	
D306	420002	Diode, Silicon, IN4001	
D307	420002	Diode, Silicon, IN4001	
D308	420002	Diode, Silicon, IN4001	
D309	420002	Diode, Silicon, IN4001	
D310	410002	Diode, Silicon, MPN3401	
D311	410000	Diode, Silicon, IN4148	
D312	410003	Diode, Silicon, IN60	
D313	410003	Diode, Silicon, IN60	
D314	410003	Diode, Silicon, IN60	
D315	410003	Diode, Silicon, IN60	
D316	410000	Diode, Silicon, IN4148	
Q301	440001	Transistor, Silicon, MPS6514	
Q302	440001	Transistor, Silicon, MPS6514	
Q303	440000	Transistor, Silicon, 2N3866	
Q304	450001	Transistor, Silicon, 2N5486	
Q305	440002	Transistor, Silicon, 2N3563	
Q306	440002	Transistor, Silicon, 2N3563	
Q307	440002	Transistor, Silicon, 2N3563	
X301	A951006	Crystal, 18 MHZ	
X302	A951007	Crystal, 11 MHZ	
P301	260006	Potentiometer, 100 $\Omega$	
PC301	831103	Printed Circuit Board	
L301	A330100	Inductor, Toroidal	
L302	330114	R.F. Choke, 15 $\mu$ h	
L303	330114	R.F. Choke, 15 $\mu$ h	
L304	Not Assigned		
L305	Not Assigned		
L306	A330104	R.F. Transformer	
L307	A330105	R.F. Inductor	
L308	A330104	R.F. Transformer	
L309	330114	R.F. Choke, 15 $\mu$ h	
L310	A330104	R.F. Transformer	
L311	A330105	R.F. Inductor	
L312	A330104	R.F. Transformer	
L313	A330106	R.F. Transformer	
L314	A330112	R.F. Transformer	
L315	A330106	R.F. Transformer	
L316	A330100	Inductor, Toroidal	
L317	A330100	Inductor, Toroidal	
L318	A330100	Inductor, Toroidal	
R301	215470	Resistor, Comp, 47 $\Omega$ , 1/4 W, 5%	
R302	215221	Resistor, Comp, 220 $\Omega$ , 1/4 W, 5%	
R303	215221	Resistor, Comp, 220 $\Omega$ , 1/4 W, 5%	
R304	215470	Resistor, Comp, 47 $\Omega$ , 1/4 W, 5%	
R305	215473	Resistor, Comp, 47 K, 1/4 W, 5%	
R306	215152	Resistor, Comp, 1.5 K, 1/4 W, 5%	

R307	215271	Resistor, Comp, 270 $\Omega$ , 1/4 W, 5%
R308	215100	Resistor, Comp, 10 $\Omega$ , 1/4 W, 5%
R309	215471	Resistor, Comp, 470 $\Omega$ , 1/4 W, 5%
R310	215221	Resistor, Comp, 220 $\Omega$ , 1/4 W, 5%
R311	215221	Resistor, Comp, 220 $\Omega$ , 1/4 W, 5%
R312	215221	Resistor, Comp, 220 $\Omega$ , 1/4 W, 5%
R313	215221	Resistor, Comp, 220 $\Omega$ , 1/4 W, 5%
R314	215221	Resistor, Comp, 220 $\Omega$ , 1/4 W, 5%
R315	215221	Resistor, Comp, 220 $\Omega$ , 1/4 W, 5%
R316	215332	Resistor, Comp, 3.3 K, 1/4 W, 5%
R317	215101	Resistor, Comp, 100 $\Omega$ , 1/4 W, 5%
R318	215101	Resistor, Comp, 100 $\Omega$ , 1/4 W, 5%
R319	215221	Resistor, Comp, 220 $\Omega$ , 1/4 W, 5%
R320	215332	Resistor, Comp, 3.3 K, 1/4 W, 5%
R321	215330	Resistor, Comp, 33 $\Omega$ , 1/4 W, 5%
R322	215105	Resistor, Comp, 1 MEG, 1/4 W, 5%
R323	215102	Resistor, Comp, 1 K, 1/4 W, 5%
R324	215562	Resistor, Comp, 5.6 K, 1/4 W, 5%
R325	215683	Resistor, Comp, 68 K, 1/4 W, 5%
R326	215221	Resistor, Comp, 200 $\Omega$ , 1/4 W, 5%
R327	215333	Resistor, Comp, 33 K, 1/4 W, 5%
R328	215681	Resistor, Comp, 680 $\Omega$ , 1/4 W, 5%
R329	215473	Resistor, Comp, 47 K, 1/4 W, 5%
R330	215103	Resistor, Comp, 10 K, 1/4 W, 5%
R331	215683	Resistor, Comp, 68 K, 1/4 W, 5%
R332	215333	Resistor, Comp, 33 K, 1/4 W, 5%
R333	215681	Resistor, Comp, 680 $\Omega$ , 1/4 W, 5%
R334	215471	Resistor, Comp, 470 $\Omega$ , 1/4 W, 5%
R335	215470	Resistor, Comp, 47 $\Omega$ , 1/4 W, 5%
R336	215471	Resistor, Comp, 470 $\Omega$ , 1/4 W, 5%
R337	215271	Resistor, Comp, 270 $\Omega$ , 1/4 W, 5%
R338	215471	Resistor, Comp, 470 $\Omega$ , 1/4 W, 5%
R339	215471	Resistor, Comp, 470 $\Omega$ , 1/4 W, 5%
R340	215221	Resistor, Comp, 220 $\Omega$ , 1/4 W, 5%
R341	Not Assigned	

QTY  
9

600000

Header Pin (Test Pins)

PC401  
PARTS LIST

C401	P/N			
C401	110023	Capacitor, Cer Disc, .1 MFD		50V
C402	140006	Capacitor, Electrol, 1000 MFD		25V
C403	140009	Capacitor, Electrol, 1500 MFD		50V
C404	110023	Capacitor, Cer Disc, .1 MFD		50V
C405	140001	Capacitor, Electrol, 33 MFD		16V
C406	110023	Capacitor, Cer Disc, .1 MFD		50V
C407	110012	Capacitor, Cer Disc, .01 MFD		50V
C408	163000	Capacitor, Compr. Trim, 7-100 PF		1000V
C409	115002	Capacitor, Disc, 2 PF, 5%		50V
C410	110012	Capacitor, Cer Disc, .01 MFD		1000V
C411	115000	Capacitor, Cer Disc, 1 PF, 5%		
C412	163000	Capacitor, Compr. Trim, 7-100 PF		
C413	135271	Capacitor, DM19, 270 PF, 5%		500V
C414	135431	Capacitor, DM19, 430 PF, 5%		50V
C415	135271	Capacitor, DM19, 270 PF, 5%		500V
C416	135561	Capacitor, DM19, 560 PF, 5%		500V

C417	135911	Capacitor, DM19, 910 PF, 5%	500V
C418	135561	Capacitor, DM19, 560 PF, 5%	500V
C419	Not Assigned		
C420	135102	Capacitor, DM19, 1000 PF, 5%	500V
C421	135152	Capacitor, DM19, 1500 PF, 5%	500V
C422	135102	Capacitor, DM19, 1000 PF, 5%	500V
C423	110023	Capacitor, Cer Disc, .1 MFD	50V
D401	420004	Diode, Silicon, MR750	
D402	420002	Diode, Silicon, IN4001	
D403	420002	Diode, Silicon, IN4001	
D404	420002	Diode, Silicon, IN4001	
D405	420002	Diode, Silicon, IN4001	
D406	410000	Diode, Silicon, IN4148	
D407	410000	Diode, Silicon, IN4148	
D408	410000	Diode, Silicon, IN4148	
D409	410000	Diode, Silicon, IN4148	
D410	410000	Diode, Silicon, IN4148	
L401	A330103	Inductor, Toroidal	
L402	A330103	Inductor, Toroidal	
L403	A330102	Inductor, Toroidal	
L404	A330102	Inductor, Toroidal	
L405	A330101	Inductor, Toroidal	
L406	A330101	Inductor, Toroidal	
L407	330114	Inductor, RFC, 15 $\mu$ h	
L408	Not Assigned		
L409	A330119	Inductor, Toroidal	
R401	235100	Resistor, Comp, 10 $\Omega$ , 1 W, 5%	
R402	215103	Resistor, Comp, 10 K, 1/4 W, 5%	
R403	215102	Resistor, Comp, 1 K, 1/4 W, 5%	
R404	215333	Resistor, Comp, 33 K, 1/4 W, 5%	
R405	215103	Resistor, Comp, 10 K, 1/4 W, 5%	
PC401	831104	Printed Circuit Board	
RLY401	730000	Relay	
	640000	Socket	

**PC501  
PARTS LIST**

	P/N		
C501	110012	Capacitor, Cer Disc, .01 MFD	50V
C502	110023	Capacitor, Cer Disc, .1 MFD	50V
C503	110012	Capacitor, Cer Disc, .01 MFD	50V
C504	110023	Capacitor, Cer Disc, .1 MFD	50V
C505	110012	Capacitor, Cer Disc, .01 MFD	50V
C506	Not Assigned		
C507	110012	Capacitor, Cer Disc, .01 MFD	50V
C508	110023	Capacitor, Cer Disc, .1 MFD	50V
C509	135102	Capacitor, DM19, 1000 PF	500V
C510	115006	Capacitor, Cer Disc, 100 PF, 5%	100V
C511	110012	Capacitor, Cer Disc, .01 MFD	50V
C512	110023	Capacitor, Cer Disc, .1 MFD	50V
C513	110023	Capacitor, Cer Disc, .1 MFD	50V
C514	110023	Capacitor, Cer Disc, .1 MFD	50V
C515	135222	Capacitor, DM15, 2200 PF, 5%	500V

C516	110023	Capacitor, Cer Disc, .1 MFD	110023	C417	50V
C517	110023	Capacitor, Cer Disc, .1 MFD	110023	C418	50V
D501	420001	Diode, Silicon, S2M	420001	C419	
D502	420001	Diode, Silicon, S2M	420001	C420	
D503	420001	Diode, Silicon, S2M	420001	C421	
Q501	440000	Transistor, Silicon, 2N3866	440000	C422	
Q502	440006	Transistor, Silicon, MRF433	440006	C423	
Q503	440007	Transistor, Silicon, MRF454	440007	D401	
Q504	440007	Transistor, Silicon, MRF454	440007	D402	
Q505	440005	Transistor, Silicon, 2N5490	440005	D403	
P501	260005	Potentiometer, 2.5 K	260005	D404	
PC501	831105	Printed Circuit Board	831105	D405	
L501	A330100	Inductor, Toroidal	A330100	D406	
L502	A330100	Inductor, Toroidal	A330100	D407	
L503	A330202	Inductor, Toroidal	A330202	D408	
L504	A330115	Inductor, Toroidal	A330115	D409	
L505	A330108	Transformer, Toroidal	A330108	D410	
L506	A330203	Inductor, Toroidal	A330203	L401	
L507	A330201	Inductor, Toroidal	A330201	L402	
L508	A330200	Inductor, Toroidal	A330200	L403	
R501	215470	Resistor, Comp, 47 $\Omega$ , 1/4 W, 5%	215470	L404	
R502	215621	Resistor, Comp, 620 $\Omega$ , 1/4 W, 5%	215621	L405	
R503	215332	Resistor, Comp, 3.3 K, 1/4 W, 5%	215332	L406	
R504	215100	Resistor, Comp, 10 $\Omega$ , 1/4 W, 5%	215100	L407	
R505	215470	Resistor, Comp, 47 $\Omega$ , 1/4 W, 5%	215470	R401	
R506	215100	Resistor, Comp, 10 $\Omega$ , 1/4 W, 5%	215100	R402	
R507	215471	Resistor, Comp, 470 $\Omega$ , 1/4 W, 5%	215471	R403	
R508	215102	Resistor, Comp, 1 K, 1/4 W, 5%	215102	R404	
R509	235100	Resistor, Comp, 10 $\Omega$ , 1 W, 5%	235100	R405	
R510	215100	Resistor, Comp, 10 $\Omega$ , 1/4 W, 5%	215100	PC101	
R511	215470	Resistor, Comp, 47 $\Omega$ , 1/4 W, 5%	215470	RLY401	
R512	225470	Resistor, Comp, 47 $\Omega$ , 1/2 W, 5%	225470		
R513	215471	Resistor, Comp, 470 $\Omega$ , 1/4 W, 5%	215471		
R514)					
R515)	245470	Resistor, Comp, 47 $\Omega$ , 2 W	245470		
R516)					
QTY					
1	810019	Screw, Nylon, 4-40 x 1/4"	810019		
1	817201	Heat Sink Transistor	817201		

PC601  
PARTS LIST

	P/N			
C601	125200	Capacitor, DM15, 20 PF, 5%	125200	500V
C602	171001	Capacitor, Variable, 2.2-34 PF	171001	
C603	125102	Capacitor, DM15, 1000 PF, 5%	125102	500V
C604	190041	Capacitor, Poly, 1000 PF, 5%	190041	600V
C605	Not Assigned			
C606	125470	Capacitor, Poly, 47 PF, 5%	125470	500V
C607	110012	Capacitor, Cer Disc, .01 MFD	110012	50V
C608	110012	Capacitor, Cer Disc, .01 MFD	110012	50V
C609	115000	Capacitor, Cer Disc, 1 PF, 5%	115000	1000V

C610	110012	Capacitor, Cer Disc, .01 MFD	50V
C611	125241	Capacitor, DM15, 240 PF, 5%	500V
C612	125270	Capacitor, DM15, 27 PF, 5%	500V
C613	Not Assigned		
C614	110012	Capacitor, DM15, .01 MFD	500V
C615	110012	Capacitor, DM15, .01 MFD	500V
RLY601	730001	Reed Relay, SPDT	12V
Q601	450001	Transistor, FET, 2N5486	
Q602	440001	Transistor, Silicon, MPS6514	
PC601	831106	Printed Circuit Board	
L601	A330110	Inductor, VFO	
L602	330117	Inductor, RFC, 1MH	
L603	A330100	Inductor, Toroidal, Transformer	
L604	330118	Inductor, RFC, 3.9 $\mu$ h	
L605	330117	Inductor, RFC, 1MH	
R601	215105	Resistor, Comp, 1 MEG, 1/4 W, 5%	
R602	215331	Resistor, Comp, 330 $\Omega$ , 1/4 W, 5%	
R603	215221	Resistor, Comp, 220 $\Omega$ , 1/4 W, 5%	
R604	215101	Resistor, Comp, 100 $\Omega$ , 1/4 W, 5%	
R605	215104	Resistor, Comp, 100 K, 1/4 W, 5%	
R606			
R607	Not Assigned		
R608	Not Assigned		
R609	215470	Resistor, Comp, 47 $\Omega$ , 1/4 W, 5%	

### PC701 PARTS LIST

	P/N		
C701	110012	Capacitor, Cer Disc, .01 MFD	50V
C702	115001	Capacitor, Cer Disc, 10 PF, 5%	1000V
C703	110023	Capacitor, Cer Disc, .1 MFD	50V
C704	110012	Capacitor, Cer Disc, .01 MFD	50V
C705	110012	Capacitor, Cer Disc, .01 MFD	50V
C706	110012	Capacitor, Cer Disc, .01 MFD	50V
C707	110012	Capacitor, Cer Disc, .01 MFD	50V
C708	110023	Capacitor, Cer Disc, .1 MFD	50V
C709	125201	Capacitor, DM15, 200 PF, 5%	500V
C710	115001	Capacitor, Cer Disc, 10 PF, 5%	1000V
C711	125470	Capacitor, DM15, 47 PF, 5%	500V
C712	125101	Capacitor, DM15, 100 PF, 5%	500V
C713	150000	Capacitor, Tantalum, 2.2 MFD	
C714	110023	Capacitor, Tantalum, .1 MFD	50V
C715	110023	Capacitor, Tantalum, .1 MFD	50V
D701	410003	Diode, Silicon, IN60	
D702	410003	Diode, Silicon, IN60	
D703	410003	Diode, Silicon, IN60	
Q701	440001	Transistor, Silicon, MPS6514	
Q702	450001	Transistor, FET, 2N5486	
Q703	440001	Transistor, Silicon, MPS6514	
IC701	460000	Integrated Circuit, MC1350P	
L701	A330112	IF Transformer	

R701	215103	Resistor, Comp, 10 K, 1/4 W, 5%	
R702	215103	Resistor, Comp, 10 K, 1/4 W, 5%	
R703	215101	Resistor, Comp, 100 $\Omega$ , 1/4 W, 5%	
R704	215102	Resistor, Comp, 1 K, 1/4 W, 5%	
R705	215470	Resistor, Comp, 47 $\Omega$ , 1/4 W, 5%	
R706	215102	Resistor, Comp, 1 K, 1/4 W, 5%	
R707	215102	Resistor, Comp, 1 K, 1/4 W, 5%	
R708	215682	Resistor, Comp, 6.8 K, 1/4 W, 5%	
R709	215103	Resistor, Comp, 10 K, 1/4 W, 5%	
R710	215101	Resistor, Comp, 100 $\Omega$ , 1/4 W, 5%	
R711	215105	Resistor, Comp, 1 MEG, 1/4 W, 5%	
R712	215105	Resistor, Comp, 1 MEG, 1/4 W, 5%	
R713	215104	Resistor, Comp, 100 K, 1/4 W, 5%	
R714	215105	Resistor, Comp, 1 MEG, 1/4 W, 5%	
R715	215224	Resistor, Comp, 220 K, 1/4 W, 5%	
R716	215102	Resistor, Comp, 1 K, 1/4 W, 5%	
R717	215152	Resistor, Comp, 1.5 K, 1/4 W, 5%	
R718	215101	Resistor, Comp, 100 $\Omega$ , 1/4 W, 5%	

PC701	831107	Printed Circuit Board	
QTY			
1	812403	Stand Off, 4-40 x 1/4 Swage	

**ELECTRICAL & CHASSIS  
BILL OF MATERIAL  
PARTS LIST**

C1	110023	Capacitor, Cer Disc, .1 MFD	50V
C2	110023	Capacitor, Cer Disc, .1 MFD	50V
C3	110023	Capacitor, Cer Disc, .1 MFD	50V
C4	110023	Capacitor, Cer Disc, .1 MFD	50V
C5	110023	Capacitor, Cer Disc, .1 MFD	50V
C6	171000	Capacitor, Variable, 1.4-13 PF	
C7	171002	Capacitor, Variable, 2 Section, 75 PF Each	
C8	171000	Capacitor, Variable, 1.4-13 PF	
C9	110012	Capacitor, Cer Disc, .01 MFD	50V
C10	125200	Capacitor, DM15, 20 PF, 5%	500V
C11	110023	Capacitor, Cer Disc, .1 MFD	50V
R1	225101	Resistor, Comp, 100 $\Omega$ , 1/2 W, 5%	
R2	215473	Resistor, Comp, 47 K, 1/4 W, 5%	
P1	A821052	Potentiometer, 10 K, Audio Taper, MIC Gain U18	
P2	A821034	Potentiometer, On-Off, 10 K, Audio Taper, Panel Mt.	
P3	A821038	Potentiometer, 10 K, Linear Taper, RF U20	
L1	A330203	Toroid, RFC, 25 $\mu$ h	
L2	A330116	Inductor, Choke, 10 MH, DC Filtering	
L3	330111	Inductor, RFC, 180 $\mu$ h	
L4	330114	Inductor, RFC, 15 $\mu$ h	
D1	430001	Diode, Zener, 5 W, IN5344B	8.2 V
I1	520001	Panel, Lamps	
I2	520001	Panel, Lamps	
S01	610000	Socket Ant. UHF S0239	
S02	610002	Connector, Male, Flush Plate Chassis, 2 Way	

S03	610007	Connector, PC Board, 22 Pin
S04	610007	Connector, PC Board, 22 Pin
S05	610007	Connector, PC Board, 22 Pin
S06	610011	Connector, PC Board, 10 Pin
S07	610008	Connector, Accessory, 12 Pin
J1	610005	Connector, Jack, 2 Way
J2	610004	Connector, Jack, 3 Way
J3	610006	Connector, Jack, Closed Circuit, Miniature
SW1	A720000	Band Switch, Wafer No. 1
SW1	A720001	Band Switch, Wafer Nos. 2 & 3
SW2	720002	Switch SPDT
SW3	710001	Switch SPDT
SW4	710001	Switch SPDT
SP1	910000	SPKR, 3", 3.2 $\Omega$
M1	960000/A841008	Meter, 0-500 $\mu$ a
QTY		
3	815106	Card File, Snap In

**CHASSIS & MECHANICAL  
BILL OF MATERIAL**

QTY	P/N	Description
1	D824020	Chassis, Main
1	C823021	Chassis, Shield
1	C823022	Front, Panel
1	C823023	Rear, Panel
1	C823024	Front Panel, Overlay
1	A821025	Mt Brkt, Band Switch
1	D824026	Cover, Top
1	D824027	Cover, Bottom
1	B822028	Base, Case Mt.
1	C823029	Mobile, Mt. Brkt
1	A821030	Vernier, Mt Brkt
1	B822031-1 & -2	Art Work, Front Panel Overlay
1	B822032	PC101, Shield Brkt
1	B822033	PC201, Shield Brkt
1	A821034	Potentiometer, 10 K, ON/OFF Sw.
1	A821035	Dial, Face
1	A821036	Mt Brkt, Spkr
1	B822037	PC301, Shield Brkt
2	A821038	Potentiometer, 10 K
1	A821039	Escutcheon, Plastic
1	C823040	TX, Heat Sink
1	A821041	L Mt Brkt, TX Heat Sink
1	A821042	R Mt Brkt, TX Heat Sink
1	B822043	Can, Shield
2	812100	Washer, Shoulder, 3/8 x 5/8, Waldow No. FW-389
9	812403	Stand-Off, 4-40 x 1/4 L Hex Swage, Waldom No. 60703
2	812404	Stand-Off, 4-40 x 3/16 L Hex Swage, Smith No. 4259
3	815101	Grommets, Rubber, GC No. 5710
13	816100	Solder Lug, No. 4 Int. Lock, Waldom No. T233

2	816201	Terminal Strip 2 Way, Smith No. 1066	
1	816200	Terminal, Bifcated, Smith No. 522001	
5	818000	Knob, Black, 3/4 Dia, K K No. S-1645-3L	
1	818001	Knob, Black, 1-5/8 Dia, K K No. S-1749-3L	
2	818002	Knob, Black, 1 Dia, K K No. S-1647-3L	
1	818200	Coupler, Universal, Jackson Bros. No. 5610	
1	818300	Ball Drive, Jackson Bros. No. 4511/DRF	
<b>PC801 B/M</b>			
<b>CRYSTAL CALIBRATOR</b>			
	P/N		
C801	125470	Capacitor, DM15, 47 PF, 5%	500V
C802	125270	Capacitor, DM15, 27 PF, 5%	500V
C803	162001	Capacitor, Trim, 3.5-65 PF	
C804	110012	Capacitor, Cer Disc, .01 MFD	100V
C805	110012	Capacitor, Cer Disc, .01 MFD	100V
C806	110012	Capacitor, Cer Disc, .01 MFD	100V
C807	115003	Capacitor, Cer Disc, 5 PF	1000V
C808	125200	Capacitor, DM15, 20 PF, 5%	500V
D801	410000	Diode, Silicon, IN4148	
IC801	460004	Integrated Circuit, CD4001	
IC802	460005	Integrated Circuit, CD4018	
IC803	460005	Integrated Circuit, CD4018	
R801	215684	Resistor, Comp, 680 K, 1/4 W, 5%	
R802	215682	Resistor, Comp, 6.8 K, 1/4 W, 5%	
R803	215205	Resistor, Comp, 2 MEG, 1/4 W, 5%	
R804	215222	Resistor, Comp, 2.2 K, 1/4 W, 5%	
SW801	710003	Switch, Slide, SPDT	
X801	951010	Crystal, 1000 KHZ	

**PS 115**  
**PARTS LIST**

	P/N		
C1	140010	Capacitor, Electrol, 29,000 MFD	25V
C2	140010	Capacitor, Electrol, 29,000 MFD	25V
C3	110026	Capacitor, Disc Ceramic, .047 MFD	1400V
C4	110026	Capacitor, Disc Ceramic, .047 MFD	1400V
D1	420005	Diode, Silicon, IN3491R, 25 Amp	
D2	420005	Diode, Silicon, IN3491R, 25 Amp	
F1	530003	Fuse Holder	
	530006	Fuse, 3 Amp (for 115 VAC)	
	530007	Fuse, 2 Amp (for 230 VAC)	
I1	520003	Lamp, Indicator	
L1	C823047	Inductor, Filter	
T1	C823048	Transformer, Power	
PL1	610001	Connector, Power, Female, 2-Way	
SW1	710002	Switch, Power, SPST	