

KT-390



LAFAYETTE

assembly
manual

STARFLITE
90 WATT TRANSMITTER

Price 50c

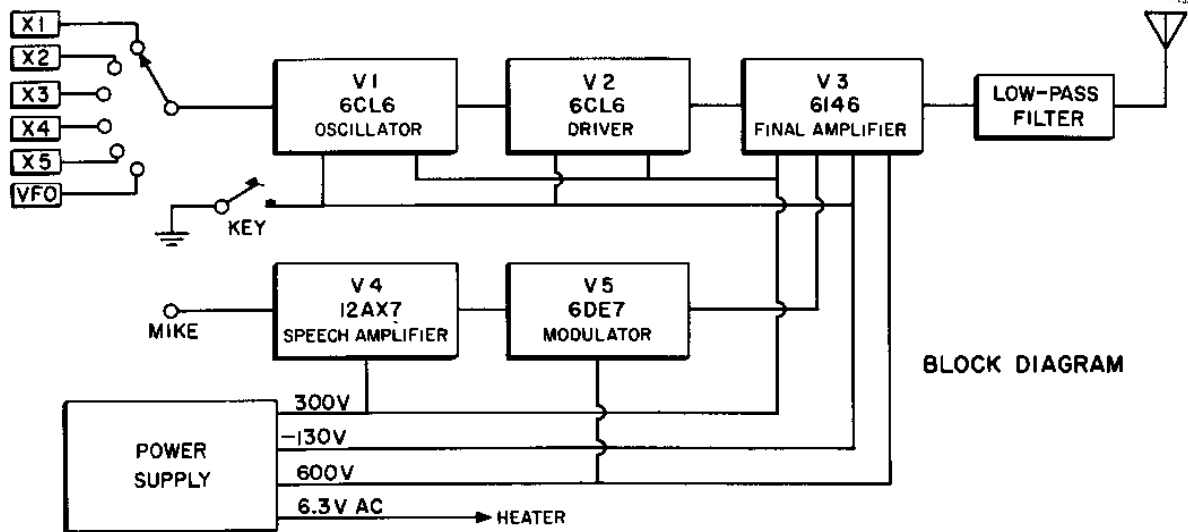

CIRCUIT DESCRIPTION

While reading the circuit description, refer to both the Block and Schematic diagrams.

OSCILLATOR

The oscillator stage, V1, functions as a modified Pierce crystal oscillator. The crystal selector switch SW-1 is used to select the desired crystal. When VFO operation is desired, the VFO output is connected to the VFO INPUT jack and V1 then operates as a buffer stage. The oscillator may be operated at the fundamental frequency of either an 80 or 40 meter crystal. The plate circuit is untuned for 80 meter operation, coil L1 having no effect in the circuit on this band. The plate circuit is slug tuned by coil L1 for operation on 40 through 10 meters.

The output of V1 is coupled to V2 (the driver stage) through capacitor C4.

DRIVER

The driver tube, V2, is operated as a class C amplifier. Its plate circuit is tuned to the desired operating frequency by coil L3 (or portions thereof, selected by Band Switch SW-2a) and variable capacitor C8 (DRIVE TUNE). This stage operates straight through on 80 and 40 meters, as a doubler on 20 meters, a tripler on 15 meters, and as a quadrupler on 10 meters.

The DRIVE LEVEL control, R5, varies the screen voltage of V2 and thus controls the output (drive), which is coupled to the grid of the final amplifier through capacitor C12.

FINAL AMPLIFIER

Final amplifier tube V3 operates straight-through on all bands as a shunt-fed, neutralized amplifier. The tank circuit is made up of C20 (FINAL TUNING), L6 (or portions thereof, selected by Band Switch SW-2b), and C22 (FINAL LOADING). C22 consists of three 450 μf paralleled sections to eliminate the need for switching fixed capacity into or out of the circuit when changing bands. C21 is added to the tank circuit on 80 meters to maintain a good L-C ratio on this band.

The output is fed through a 3-section low-pass filter with a cut-off point of approximately 34MC, effectively suppressing RF energy above this frequency. The output should be connected to a 50-75 ohm unbalanced line.

Grid or Plate current of the final amplifier is read by proper positioning of switch SW-4 (METER switch). In the "Grid" position, the meter reads the voltage developed across resistor R10, and thus, in effect, measures the grid current passing through this resistor.

In the "Plate" position, the meter reads the voltage developed across the resistor R13, and thus measures the current drawn through this resistor. Although cathode current is actually the combined grid, screen, and plate current, the reading may be taken as a true indication of plate current. The error caused by the addition of grid and screen current is very small and on the legal side.

SPEECH AMPLIFIER

V4, a twin triode, operates as a conventional resistance-coupled audio amplifier. The output of the second triode section is coupled to the first half of modulator tube V5 through capacitor C28.

MODULATOR

The modulator tube V5 consists of two dissimilar triodes, one with a power rating of 1.5 watts and the other 7 watts. The output of the lower power triode is coupled directly to the grid of the higher power triode which is actually the modulator. The cathode of the modulator section is coupled to the screen grid of V3 (final amplifier) through R25 and C30.

The bias on V5 is so arranged that, with no audio input signal, conduction of the tube is limited (low). This allows the screen voltage of the final amplifier V3 to remain at a low value, thus reducing the plate current of V3 to a low resting state. When an audio signal is applied to V5, conduction in the modulator section increases, raising the screen voltage of V3. This causes an increase in the plate current of V3 with modulation producing a controlled-carrier effect.

GRID BLOCK KEYING

Keying is achieved in the following way: With the key plug inserted and in the key up position, a high bias voltage (several times the normal grid bias) is placed on the grids of tubes V1, V2 and V3. This cuts these tubes off and there is no transmitter output.

In the key down position, R8 is shorted, removing the high bias voltage from V1 and V2. Also, the bias voltage to V3 is reduced to a normal operating value through R9. The amount of fixed bias on V3 is sufficient to protect the tube should the drive be accidentally removed. The values of R8 and C2 were chosen to provide the most desirable waveform on CW.

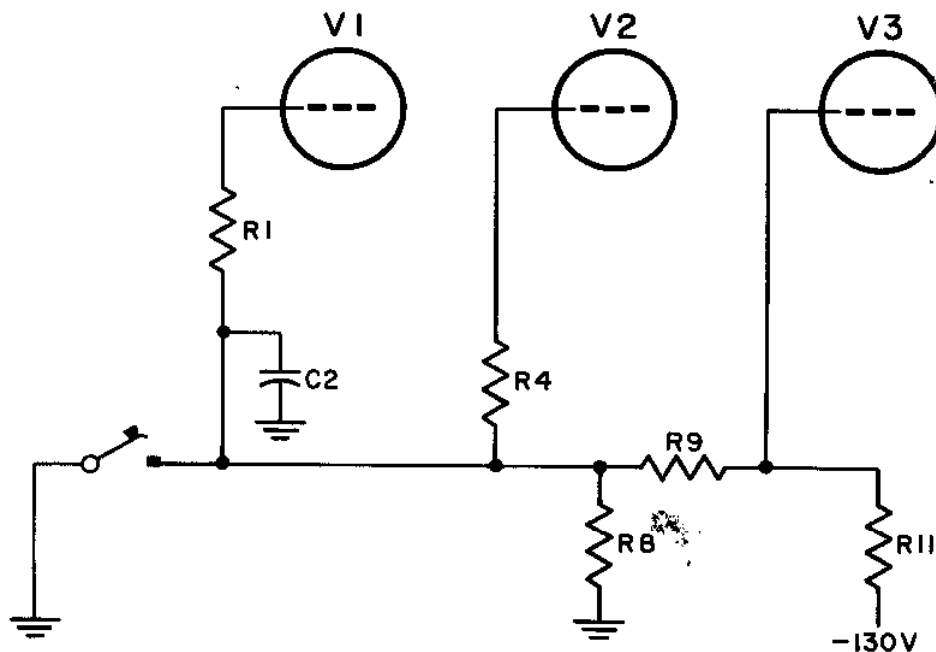

GRID BLDCK KEYING

POWER SUPPLY

The B+ supply is derived from four silicon diodes (D2, D3, D4, D5) in a voltage doubler circuit. Filtering is provided by C34, C35, C36, and resistors R28, R29.

The bias voltage for grid block keying is developed by silicon diode D-1 in a half-wave rectifier circuit. Filtering is provided by C33 and R27.

A separate winding provides 6.3 volts at 4 amps at the accessory power socket for VFO filaments or other accessory equipment.

OPERATION

An Amateur Radio Operator and Station License must be obtained before placing this transmitter on the air. If you require any information regarding licensing and amateur frequency allocations, contact the Federal Communications Commission (FCC) or the American Radio Relay League (ARRL).

ANTENNAS

The pi network output circuit of the KT-390 will match pure resistive loads of 50 to 75 ohms. A simple "dipole" antenna, constructed so that its length is a half wavelength at the frequency of operation, offers a good match for this transmitter. Other antennas falling into the 50-75 ohm range are beams, verticals, and trapped antennas. Useful information on this subject can be found in the Radio Amateur's Handbook, Radio Handbook or the ARRL Antenna Book.

CRYSTAL OPERATION

Recommended crystals for operation on the various bands are as follows:

<u>BAND</u>	<u>FUNDAMENTAL CRYSTALS</u>
80 meters	160 or 80 meter crystals
40 meters	80 or 40 meter crystals
20 meters	80 or 40 meter crystals
15 meters	40 meter crystals
10 meters	40 meter crystals

Pin spacing 0.486" Pin size .093 dia.

NOVICE OPERATION

Novice operation is restricted to the following frequencies:

<u>BAND</u>	<u>FREQUENCY ALLOCATION</u>
80 meters	3700 - 3750KC
40 meters	7150 - 7200KC
15 meters	21,100 - 21,250KC

Novice power input is limited to 75 watts. In the operating instructions, the final amplifier is loaded to 120 ma for novice operation (as opposed to 150 ma for regular operation). This keeps power input within the present novice power limitation.

CAUTION

Be sure to check the latest FCC regulations regarding amateur frequency allocations and power input requirements. When ordering crystals, be sure to stay well within the assigned bands of frequencies or a violation will result.

ACCESSORY SOCKET

The accessory socket at the rear of the transmitter supplies the following:

6.3V AC at 4 amps	Pin 7
300V DC at 50 ma	Pin 3
* -50V DC Bias	Pin 8
110V AC (for Relay)	(Pin 5)
	(Pin 6)
Ground	Pin 1

* This bias voltage has been made available for grid block keying of a VFO. Slight modification of the VFO may be necessary in order to make use of this voltage. Information on any changes necessary for grid block keying of your VFO can usually be obtained from the manufacturer.

NOTE: When using a VFO with an output impedance lower than 47K (this applies to link-coupled types as well), it will be necessary to add a decoupling capacitor in series with the VFO input to the transmitter.

OPERATING INSTRUCTIONS FOR "AM" OR "CW"

1. Plug the line cord into an AC outlet. Make sure the antenna is connected and that desired crystals (or VFO) are installed.
2. Place the MODE switch in the "standby" position.
3. Set DRIVE LEVEL and DRIVE TUNE to approximately 1.
4. Using the CRYSTAL SWITCH, select desired crystal (or VFO).
5. Select the desired BAND.
6. Set the FINAL TUNING control to the panel marking for the band being used.
7. Set the FINAL LOADING control fully counter-clockwise.
8. Set the METER switch to "Grid".
9. Set the MODE switch to "Tune".
10. Adjust DRIVE TUNE for maximum grid reading on the meter.
11. Adjust DRIVE LEVEL for 2.5 ma grid current.
12. Change METER switch to the "Plate" position.
13. Set MODE switch to "AM".
14. Adjust FINAL TUNING for minimum plate current reading (dip).
15. Set MODE switch to CW.
16. Advance the FINAL LOADING control clockwise in small steps, adjusting the FINAL TUNING for minimum plate current (dip) after each step. The transmitter should be loaded to:
120 ma for NOVICE operation,
150 ma for REGULAR operation.
17. Set METER switch to "Grid". Re-adjust DRIVE TUNE for a maximum grid reading, then re-set DRIVE LEVEL for 2.5 ma.
18. Return METER switch to "Plate" and the MODE switch to "STBY".

1400
101007

FOR CW OPERATION

1. Insert key plug in KEY jack.
2. To transmit, switch MODE to "CW" and proceed.

FOR AM OPERATION

1. If inserted, remove key plug (or close the shorting bar if the key is so equipped).
2. Attach microphone to MIKE connector.
3. To transmit, switch MODE to "AM" and proceed.

OPERATING NOTES

1. Operating the transmitter without a crystal (or VFO), a proper antenna or dummy load will result in component failure.
2. Operating the transmitter with the final amplifier not tuned to resonance (minimum plate current) may damage the final amplifier tube.
3. Never switch directly from OFF to the AM or CW positions or the final amplifier tube will be damaged. Always switch to the "STBY" position first, leaving the mode switch in this position for at least 60 seconds before attempting to operate the transmitter. This will allow the tubes to reach normal operating temperatures.
4. If you change your operating frequency by more than a few kilocycles, it may be necessary to re-tune the driver and final amplifier stages.
5. Never cover the perforations in the top of the cover or ventilation will be restricted. Failure to observe this precaution will result in sharply reduced component and tube life.

IN THE EVENT OF DIFFICULTY

- A. If all of the tubes remain unlit when the transmitter is turned on, or if they suddenly go off, check to see that the fuse is intact. If it is not, replace it with one of the same value (see parts list). Should the fuse blow again, a short or a component failure must be suspected.
- B. Carefully re-check all wiring and values of components inserted against the instructions. If you have not already done so, trace each lead and component in the pictorials with a colored pencil. It is frequently helpful to have a friend check your work with you as there is a tendency for the constructor to repeat his errors.
- C. Inspect all solder connections carefully. A large number of kits returned for repair have been found defective due to poor solder connections. Therefore, any doubtful connections should be re-heated to make sure they are correctly soldered.
- D. Check for small pieces of solder or wire which may have fallen into the chassis. Make sure that the use of excess solder has not caused a short between adjacent terminals or nearby wiring, particularly on tube sockets and switch terminals.
- E. Check all tubes with a tube tester, or by substitution with tubes of the same type and known to be good.
- F. A resistance chart has been included as an aid in locating defective components and to permit a careful stage-by-stage check of the unit. If any of the readings obtained differ widely from those provided in the chart, recheck that part of the circuit involved carefully. If the wiring and connections are correct, component failure must be suspected.
- G. If you are still unable to locate the trouble and a vacuum-tube voltmeter is available, check the voltage readings, referring to the voltage chart. A variation of $\pm 15\%$ may be considered normal. If any voltage is incorrect, recheck that part of the circuit involved carefully. If the wiring and connections have already been checked and found correct, the trouble will probably be due to a defective part (tube, capacitor, resistor, etc.).

CAUTION: EXERCISE GREAT CARE WHEN MAKING ANY CHECKS WITH THE UNIT TURNED ON. If there are obvious signs of a short circuit (components becoming discolored or smoking) do not attempt to make voltage checks. Switch the unit off and remove the AC plug until the short circuit has been located and the trouble corrected.

Parts found defective may be returned (postpaid) to us for replacement. If they are covered by the replacement warranty, new parts will be sent to you at no charge. All packages should be addressed to the Kit Adjustment Division.

<u>Part No.</u>	<u>Circuit Designation</u>	<u>Description</u>	<u>Quantity</u>
-----------------	----------------------------	--------------------	-----------------

CAPACITORS

12-219	C23/R16	Tube-R-Kap (combined 560K ohms / 100 μmf)	1
12-205	C18	0.003 μf 1000V feed-through	1
12-193	C36a, b	40-40 μf 450V electrolytic	1
12-194	C34, 35	30 μf 450V electrolytic (with insulating covering)	2
12-196	C25	10 μf 350V electrolytic (with insulating covering)	1
12-220	C33a, b	10-10 μf 150V electrolytic (with insulating covering)	1
12-197	C8	25 μmf variable (DRIVE TUNE)	1
12-198	C20	140 μmf variable (FINAL TUNING)	1
12-199	C22	3 gang variable, 450 μmf per section (FINAL LOADING)	1
12-190	C2, 5, 6, 7, 9, 11, 13, 14, 15, 16, 17, 37, 38, 39	0.005 μf 500V 20% ceramic disc	14
12-2	C1	0.001 μf 500V 10% ceramic disc	1
12-191	C4	50 μmf 500V 10% ceramic disc	1
12-34	C3, 12, 29	100 μmf 500V 10% (N750) ceramic disc	3
12-22	C27	470 μmf 500V 10% ceramic disc	1
12-192	C21	68 μmf 3KV 10% ceramic disc	1
12-79	C24	0.002 μf 500V 10% (may be marked 2000)	1
12-200	C40, 43	47 μmf 300V 10% molded mica	2
12-201	C41, 42	180 μmf 300V 10% molded mica	2
12-202	C19	0.001 μf 2000V 20% molded mica (marked 12-202)	1
12-203	C10	120 μmf 1500V 20% molded mica (marked 12-203)	1
12-204	C26, 28	0.005 μf 400V 20% molded paper	2
12-82	C31, 32	0.01 μf 600V 20% molded paper	2
12-11	C30	0.05 μf 400V 20% molded paper	1

COILS, CHOKES, TRANSFORMERS

23-37	L2	RF choke 1 mh	1
23-38	L4	RF choke 1.1 mh	1
23-39	L5	RF choke .4 μh	1
23-40	L10,11	.32 μh low-pass filter coil (yellow dot)	2
23-41	L7, 9	.44 μh low-pass filter coil (green dot)	2
23-42	L8	.5 μh low-pass filter coil (blue dot)	1
23-32	L1	40 meter oscillator coil	1
23-33	L3	Driver plate coil	1
23-43	PC	Parasitic choke	1
23-34	L6	Pi-net tank coil	1
15-43	T1	Power transformer	1

SWITCHES

14-46	SW-3a, b	5-position 1 section rotary (MODE switch)	1
14-47	SW-1	6-position 1 section rotary (CRYSTAL switch)	1
14-45	SW-2a, b	5-position 2 section rotary (BAND switch)	1
14-17C	SW-4	DPDT slide switch (METER)	1

TERMINAL POSTS

20-23	3-lug	1
20-22	4-lug	2
20-47	3-lug	1
20-74	1-lug	1
20-20	2-lug	1
20-311	4-lug	1
20-312	5-lug	1
20-313	5-lug	1
20-305	3-lug	1
20-314	3-lug	1
20-317	2-lug	1
20-43	2-lug	1

<u>Part No.</u>	<u>Circuit Designation</u>	<u>Description</u>	<u>Quantity</u>
SOCKETS, JACKS, CONNECTORS			
19-46		Octal tube socket	2
19-30		Noval tube socket	4
19-45		Crystal socket	5
19-3		RCA phono jack (VFO input)	1
20-282		Coaxial connector (RF OUTPUT)	1
19-25		Closed-circuit jack (KEY jack), with hardware	1
20-228		Mike connector (MIKE input), with hardware	1
TUBES AND DIODES			
26-51	V3	6146 tube	1
26-38	V1, V2	6CL6 tube	2
26-1	V4	12AX7 tube	1
26-52	V5	6DE7 tube	1
17-23	D2, 3, 4, 5	Silicon diode (marked 1723)	4
17-24	D1	Silicon diode (marked 1724)	1
SHEET METAL PARTS			
10-152		Cover plate	1
10-151		Shield bracket	1
10-150		Shield bracket	1
10-149		Crystal socket bracket	1
10-148		Final amplifier shield (rear)	1
10-147		Final amplifier shield (front)	1
10-146		Center shield	1
10-145		Low-pass filter housing	1
10-144		Escutcheon	1
10-143		Cover	1
10-142		Bottom plate	1
10-141		Chassis	1
MISCELLANEOUS			
27-5		0-1 ma meter	1
20-173		Tube shield	1
20-304		Tube shield	3
20-290		Ceramic plate cap	1
20-308		Ceramic standoff terminal	3
20-310		Pilot light socket	1
20-309		Standoff insulator	2
20-198		Pilot lamp	1
20-11		Pilot lamp jewel (red)	1
20-315		Foot (Polyethylene, gray)	4
20-318		AC line cord	1
20-215		Strain relief	1
20-175		Fuse holder	1
20-12		3 amp fuse, 3AG	2
20-210		1/4" grommet	2
20-75		Electrolytic mounting wafer	1
20-33		1/2" grommet	1
SHAFTS, BUSHINGS, KNOBS			
22-150		1/4" diameter shaft	1
22-90		3/8" panel bushing for 1/4" shaft (with hex nut)	3
22-147		Shaft coupler	1
18-70		Knobs, small	5
18-69		Knobs, large	2
HARDWARE			
22-10		4-40 x 1/4" machine screw	34
22-11		6-32 x 1/4" machine screw	15
22-42		8-32 x 3/8" machine screw	4

<u>Part No.</u>	<u>Circuit Designation</u>	<u>Description</u>	<u>Quantity</u>
HARDWARE (cont.)			
22-149		4-40 x 7/8" machine screw	1
22-66		2-56 x 1/2" machine screw	5
22-146		6-32 x 3/16" machine screw	5
22-144		6-32 x 3-3/4" bolt	1
22-116		#4 x 1/4" sheet metal screw	10
22-152		#8 x 3/8" sheet metal screw (nickel plated)	4
22-92		4-40 x 3/8" machine screw	1
22-27		8-32 x 1/4" machine screw	4
22-93		#8 x 3/8" sheet metal screw (hex head)	20
22-16		#4 internal tooth lockwasher	36
22-28		#8 internal tooth lockwasher	12
22-122		#2 internal tooth lockwasher	5
22-142		#8 flat steel washer	2
22-154		#6 split lockwasher	3
22-21		3/8" internal tooth lockwasher	7
22-143		Fiber washer	1
22-17		#6 internal tooth lockwasher	28
22-140		Cork washer	3
22-14		4-40 hex nut	36
22-46		2-56 hex nut	5
22-26		8-32 hex nut	8
22-15		6-32 hex nut	28
22-145		5/16" hex nut (for C18)	1
22-20		3/8" hex nut	6
20-24		#6 solder lug	1
22-151		6-32 x 7/16" spade lug	8
20-100		Double solder lug	2
22-106		Solder lug	4
22-141		Thumbscrew, 8-32 x 1/2"	1
20-83		#8 solder lug	1
22-156		6-32 x 1/4" spade lug	2
WIRE AND SLEEVING			
21-15		#22 Black lead	24"
21-11		#22 Yellow lead	60"
21-69		#22 Gray lead	96"
21-25		#22 Red/White lead	108"
21-13		#22 White lead	72"
21-14		#22 Blue lead	60"
21-87		#18 Yellow lead	60"
21-86		#20 Bare wire	48"
21-18		Yellow, cotton varnished sleeving	30"
21-19		Black, vinyl sleeving	12"
21-88		#22 Red lead, heavy insulation	30"
20-104A		Solder, 15-ft. roll	1

NOTE: To test the transmitter after completion, it will be necessary to construct a dummy load. You will need a coaxial connector (PL-259 or equivalent), a 75 watt light bulb, and about 12 inches of #16 bare wire. You may wish to purchase these parts now to avoid delay after construction.

IMPORTANT: For convenience in packing, the AC power transformer has been temporarily mounted on the main chassis. Please remove this transformer before beginning construction. Instructions for its installation will be provided at the proper time.

PARTS LIST

<u>Part No.</u>	<u>Circuit Designation</u>	<u>Description</u>	<u>Quantity</u>
RESISTORS			
13-272	R28, 29	150 ohms 8 watt, wire-wound	2
13-273	R30	25K ohms 30 watt, wire-wound (center-tapped)	1
13-217	R2	15K ohms 2 watt (brown-green-orange-silver)	1
13-267	R26	12K ohms 2 watt (brown-red-orange-silver)	1
13-215	R3, 7	1.5K ohms 2 watt (brown-green-red-silver)	2
13-72	R25	10K ohms 2 watt (brown-black-orange-silver)	1
13-269	R6	6.8K ohms 2 watt (blue-gray-red-silver)	1
13-1	R1	100K ohms 1/2 watt (brown-black-yellow-silver)	1
13-50	R4	33K ohms 1/2 watt (orange-orange-orange-silver)	1
13-48	R8	10K ohms 1/2 watt (brown-black-orange-silver)	1
13-51	R9, 15, 20	4.7K ohms 1/2 watt (yellow-violet-red-silver)	3
13-280	R11	18K ohms 1 watt (brown-gray-orange-silver)	1
13-45	R18, 19	470K ohms 1/2 watt (yellow-violet-yellow-silver)	2
13-4	R14	47K ohms 1/2 watt (yellow-violet-orange-silver)	1
13-3	R17	2.2 megohm 1/2 watt (red-red-green-silver)	1
13-226	R24	33K ohms 1 watt (orange-orange-orange-silver)	1
13-75	R23	1.5 megohm 1/2 watt (brown-green-green-silver)	1
13-118	R27	330 ohms 1/2 watt (orange-orange-brown-silver)	1
13-99	R13	10 ohms 1/2 watt (brown-black-black-silver)	1
13-19	R12	2.2K ohms 1/2 watt (red-red-red-silver)	1
13-281	R10	620 ohms 1/2 watt 5% (blue-red-brown-gold)	1
13-144	R22	22 megohm 1/2 watt (red-red-blue-silver)	1
11-57	R5	25K ohms 4 watt wire-wound (DRIVE LEVEL)	1
11-58	R21	100K ohms 1/4 watt potentiometer	1

SPECIFICATIONS

POWER INPUT 90 watts CW and controlled-carrier phone

OUTPUT LOAD IMPEDANCE 50 - 75 ohms

OUTPUT COUPLING Pi-network (coaxial)

BAND COVERAGE 80, 40, 20, 15 and 10 meters

OPERATION CRYSTAL or external VFO

FRONT PANEL CONTROLS..... METER switch
MODE switch
DRIVE LEVEL
CRYSTAL switch
DRIVE TUNE
BAND switch
FINAL TUNING
FINAL LOADING

TUBE COMPLEMENT 1 - 6CL6, Crystal Oscillator
1 - 6CL6, Driver
1 - 12AX7/ECC83, Speech Amplifier
1 - 6DE7, Modulator
1 - 6146, Final Amplifier

POWER REQUIREMENTS 117 volts 50/60 cycles AC, 225 watts

DIMENSIONS..... Width - 13-1/8"
Depth - 12" (incl. knobs)
Height- 6-1/4" (incl. rubber feet)

SHIPPING WEIGHT..... 28 lbs.

THE LAFAYETTE ELECTRONICS MANUFACTURING CORP. RESERVES THE RIGHT TO MAKE DESIGN CHANGES, ADDITIONS, OR MODIFICATIONS TO ITS PRODUCTS WITHOUT INCURRING ANY OBLIGATION TO INCORPORATE THEM IN PRODUCTS PREVIOUSLY SOLD.

RESISTORS CAPACITORS AND DIODES

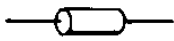

1/2 WATT RESISTOR



1 WATT RESISTOR

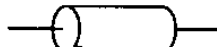

2 WATT RESISTOR



DIODE

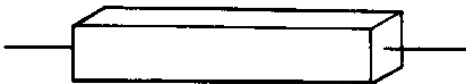

8 WATT RESISTOR

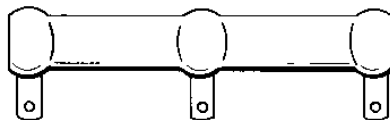

30 WATT RESISTOR



CERAMIC DISC CAPACITOR

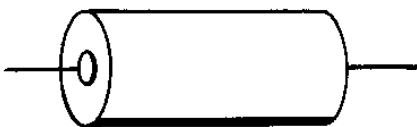

ELECTROLYTIC CAPACITOR



MOLDED TUBULAR CAPACITOR



FEED THROUGH CAPACITOR



MOLDED MICA CAPACITOR

COILS AND CHOKES



DRIVER PLATE COIL
(23-33)

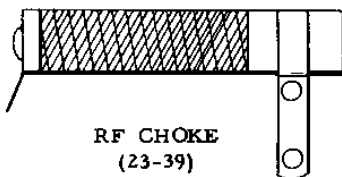

RF CHOKE
(23-39)

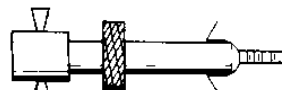

OSCILLATOR COIL
(23-32)

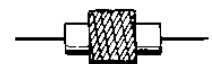

RF CHOKE
(23-37)



PARASITIC CHOKE
(23-43)



(23-40)

(23-41)

(23-42)



RF CHOKE
(23-38)

TERMINAL POSTS

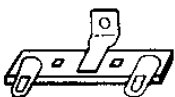

20-20



20-23



20-22



20-311



20-317



20-43



20-74



20-305



20-314



20-47





























20-313

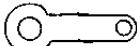













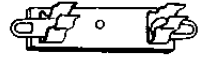

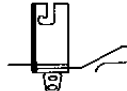
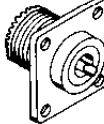
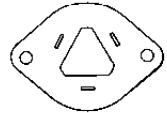
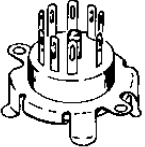

20-312

HARDWARE

					
2-56 x 1/2" SCREW (22-66)	#2 LOCKWASHER (22-122)	2-56 HEX NUT (22-46)	5/16" HEX NUT (22-145)	3/8" HEX NUT (22-20)	3/8" LOCKWASHER (22-21)
			#4 lockwasher" data-bbox="545 232 572 245"/>		
4-40 x 1/4" SCREW (22-10)	4-40 x 3/8" SCREW (22-92)	4-40 x 7/8" SCREW (22-149)	#4 LOCKWASHER (22-16)	4-40 HEX NUT (22-14)	SOLDER LUG (22-106)
					
6-32 x 3/16" SCREW (22-146)	6-32 x 1/4" SCREW (22-11)	#6 SPLIT LOCKWASHER (22-154)	#6 LOCKWASHER (22-17)	6-32 HEX NUT (22-15)	#6 SOLDER LUG (20-24)
		#8 lockwasher" data-bbox="412 372 442 385"/>	#8 x 1/2 inch flat washer" data-bbox="542 372 572 385"/>		
8-32 x 1/4" SCREW (22-27)	8-32 x 3/8" SCREW (22-42)	#8 LOCKWASHER (22-28)	#8 x 1/2" FLAT WASHER (22-142)	8-32 HEX NUT (22-26)	#8 SOLDER LUG (20-83)
					
#4 x 1/4" S. M. SCREW (22-116)	#8 x 3/8" S. M. SCREW (22-152)	#8 x 3/8" S. M. SCREW (22-93)	6-32 x 1/4" SPADE LUG (22-156)	6-32 x 7/16" SPADE LUG (22-151)	DOUBLE SOLDER LUG (20-100)

MISCELLANEOUS

				
TUBE SHIELD (20-304)	TUBE SHIELD (20-173)	1/2" GROMMET (20-33)	1/4" GROMMET (20-210)	FUSE HOLDER (20-175)
				
SHAFT COUPLER (22-147)	POTENTIOMETER (11-58)	PILOT LIGHT SOCKET (20-310)	COAX CONNECTOR (20-282)	MOUNTING WAFER (20-75)
				
NOVAL SOCKET (19-30)	OCTAL SOCKET (19-46)	XTAL SOCKET (19-45)	STRAIN RELIEF (20-215)	SINGLE JACK (19-3)
				
CERAMIC STANDOFF TERMINAL (20-308)	STANDOFF INSULATORS (20-309)	CORK WASHER (22-140)	FIBER WASHER (22-143)	PANEL BUSHING (22-90)

TOOLS YOU WILL NEED

Just a few standard tools are all you will need to successfully assemble this kit. You should use a small iron (about 25 to 50 watts) for soldering. A pair of long-nose pliers, a pair of diagonal or side-cutting pliers, two screwdrivers (1/4" and 1/8" blade) and a small adjustable wrench complete your tool requirements.

STEP BY STEP INSTRUCTIONS

The instructions which follow have been carefully planned and arranged in the most logical and practical sequence possible. Skilled engineers and technical writers have prepared these instructions while actually assembling samples of this kit. We are certain we have provided you with the best and fastest method of assembling your kit.

EACH INSTRUCTIONAL STEP SHOULD BE READ AND THOROUGHLY UNDERSTOOD BEFORE IT IS PERFORMED. In this way, errors will be avoided. Check off each step in the check space () provided. In this way you will avoid omitting any steps. You might also use a colored pencil to cross out each lead and component on the wiring pictorials after insertion.

Assembly and wiring pictorials have been provided to assist you in following the step-by-step instructions. All components have been assigned letter and/or number designations. Those components which also appear on the schematic diagram have generally been assigned the same designations on the wiring pictorials. Other components, such as terminal strips, solder lugs, etc., have been assigned letter and/or number designations.

The instructions tell you when to solder and when not to solder a connection. When you see the abbreviation "NS" (No Solder) after or during a step, simply wrap or crimp the lead to the terminal and proceed to the next step. When the final lead is connected to this terminal the abbreviation "S" (Solder) will follow. The figure which appears with this solder instruction will indicate the number of leads which should be connected to that terminal or lug when the solder instruction is given. Thus, if a step reads, "Connect the orange lead to TP-2 lug 1 (S-3)", it means that there will be three leads connected to this lug at the time it is soldered.

NOTES ON WIRING

Each kit is supplied with more than enough insulated lead for complete wiring. A length of insulated lead, unless otherwise specified, should have about 1/4" of insulation removed or "stripped" from each end. Excessive wire exposure increases the possibility of shorts to nearby wiring or terminals. Use a razor blade or sharp knife to cut off the insulation; during this operation, be sure not to cut into the wire itself. The length to which each lead is to be cut is specified in the step-by-step instructions, and allowance has been made for the removal of the insulation from each end. The lead supplied is solid wire, but some of the transformer leads are stranded; the latter should be tinned (coated with solder) before connecting to the specified point. To prepare stranded leads, remove a 1/4" length of insulation from the end of the lead, twist all the strands together with your fingers, and tin the end. To connect a lead to a lug, put about three-quarters of the bared end of the lead through the hole in the lug, and then, using the long-nose pliers, wrap the wire around the lug. The lengths to which component leads are to be cut are also specified in the instructions. For example, if you are instructed to cut each lead of a capacitor to 1", then the prepared component should have a 1" length of wire on each side.

NOTES ON SOLDERING

The importance of good soldering technique in the construction of kits cannot be over-emphasized. Good solder joints are essential if you are to realize the quality and stability of performance that has been engineered into this unit. If you are inexperienced in soldering, we suggest that you spend a little time practicing with pieces of scrap wire and an old tube socket or terminal strip before attempting to do any soldering on your kit. The purpose of soldering an electrical connection is to provide a permanent electrical bond between the wires and terminals to be joined. This prevents the formation of corrosion which insulates or produces unwanted resistance between the joined parts. It is not at all difficult to make a good solder connection that will provide the required electrical bond if you will simply observe a few basic rules for good soldering.

1. Use only good quality, rosin-core solder made specifically for radio and television use; a good composition is 60 per cent tin and 40 per cent lead (usually indicated as 60/40). Acid core solder or paste flux must NOT, under any circumstances, be used, as the corrosive effects of these materials will cause much damage to the circuit components.

CAUTION

THE USE OF ACID CORE SOLDER OR PASTE FLUX ON THIS KIT OR ANY PORTION THEREOF AUTOMATICALLY VOIDS OUR WARRANTY COVERAGE.

2. Use a good soldering iron, 25-50 watts. The tip of the iron must be kept clean and well tinned, in accordance with the instructions of the soldering iron manufacturer, to obtain consistently good connections. The tip should present a bright appearance and be free of excess solder. An old rag or a pad of steel wool may be used to wipe the hot tip clean occasionally during use.
3. Be sure leads and terminals to be joined are clean and free of wax or corrosion before soldering. The solder will not adhere properly to the joint if the leads and terminals are dirty or corroded, and will usually result in a "cold" or high resistance connection.
4. A good mechanical connection should always be made before soldering, by crimping the leads on the terminals with your pliers. Do not rely on solder alone for physical strength. Stranded leads should always be tinned with solder before being connected.
5. To solder properly, apply the iron to the joint for a few seconds; then apply the solder and hold the iron on the connection until the solder flows freely. The solder must flow completely over the connection. Simply melting drops of solder onto the connection will not produce the desired results, but will result in a "cold" solder connection. This presents a dull and pitted or "grainy" appearance. A good connection will have a smooth and shiny appearance. Remember, the joint itself must be heated sufficiently to melt solder before the solder will flow smoothly and freely in and around the connection; however, you must be careful not to apply heat too long. Excessive heat from the iron may damage components and insulation on wires connected to the joint. When soldering a joint having a small component connected to it (a 1/2 watt resistor, for example), the component may be protected from excessive heat from the iron by grasping the lead between the joint and the component with long-nose pliers. The pliers will then conduct most of the heat away from the component, preventing overheating. Do not use too much solder when making a connection. Use only enough to completely cover all leads and to fill lug or terminal holes. Excessive use of solder may result in the formation of solder "bridges" or shorts between adjacent terminals or nearby wiring, particularly on tube sockets and switch terminals. Also, solder may flow into the switch contacts, destroying switch action.

WIRING PROCEDURE

For clarity, the illustrations showing the wiring of the unit have been divided into several wiring pictorials. Each one illustrates a group of components and/or leads which are not duplicated on the other pictorials. The instructions will refer you to the appropriate pictorial in all cases. When you have completed the wiring shown in one pictorial, you will be referred to another pictorial which will illustrate the next stage of wiring only. For an overall view of a completed unit, photographic views have been included. Although all pictorials are reproduced in the pages of the manual, certain ones have been selected for reproduction on large inserts. These may be attached to the wall above your work bench and referred to during wiring.

To assist you in assembling this kit, mechanical assembly views are shown which supplement the step-by-step instructions. In order to clarify the drawings, not all the mounting hardware is shown. The amount of hardware used to assemble each part is specified in the step-by-step instructions.



MECHANICAL ASSEMBLY

IMPORTANT: The AC power transformer must be removed from the chassis before beginning construction.

REFER TO PICTORIAL 1

NOTE: 4-40 hardware (2) means that you should use two 4-40 x 1/4" screws, two #4 lockwashers and two 4-40 hex nuts. Unless otherwise directed, always place the washer directly beneath the nut when installing hardware.

1. (✓) Mount V4 tube socket (19-30) from the topside of the chassis, using 4-40 hardware (2). Orient the blank space between pins as shown.
2. (✓) Mount a 5-lug terminal post (20-312) next to V4 socket, using 4-40 hardware (2).
3. (✓) Mount V5 tube socket (19-30) and a solder lug (22-106), using 4-40 hardware (2). Orient socket pins as shown.
4. (✓) Mount V2 tube socket (19-30) and a solder lug (22-106) as shown, using 4-40 hardware (2).
5. (✓) Mount V1 tube socket (19-30) and a solder lug (22-106) as shown, using 4-40 hardware (2).
6. (✓) Mount V3 tube socket (19-46), using 4-40 hardware (2). Orient the socket with the key-way as shown.
7. (✓) Mount the accessory socket (19-46) on the rear apron of the chassis (from the inside), using 4-40 hardware (2). Note the position of the key-way.
8. () Mount a 3-lug terminal post (20-47) on the rear apron of the chassis as shown, using 4-40 hardware (1).
9. (✓) Mount a phono jack (19-3) on the rear apron of the chassis (from the inside), using 4-40 hardware (2). Orient as shown.
10. () Mount a 4-lug terminal post (20-22) next to V1 socket, using 4-40 hardware (1).
11. (✓) Mount a 3-lug terminal post (20-23) next to the large cut-out for the power transformer. Use 4-40 hardware (1).
12. (✓) Mount a 3-lug terminal post (20-314) to the right of V2 socket, using 4-40 hardware (1). Carefully observe the position in which the post is installed -- be sure to use the right mounting hole in the chassis.
13. (✓) Mount a 3-lug terminal post (20-305) near V2 socket as shown, using 4-40 hardware (1).
14. (✓) Mount a 5-lug terminal post (20-313) to the left of V2 socket as shown, using 4-40 hardware (1).
15. (✓) Select the closed-circuit jack (19-25). Remove the hex nut and flat washer. Install the jack in the lower hole in the front apron, orienting the solder lugs as shown. Place the flat washer over the bushing and tighten the hex nut firmly (but not excessively -- this nut must later be removed in order to mount the escutcheon). Bend the lower lug up, away from the chassis.
16. (✓) Mount the DRIVE LEVEL control (11-57) next to the jack, using a 3/8" lockwasher on the inside of the chassis and a 3/8" hex nut on the outside. Do not tighten excessively -- the nut must later be removed in order to mount the escutcheon.
17. (✓) Mount the MODE switch (14-46) in the position shown, using a 3/8" lockwasher and 3/8" hex nut to secure it. Make sure the locating lug on the face of the switch enters the small hole provided for it in the chassis. Do not tighten the hex nut excessively at this time.
18. (✓) Install the level control (11-58) between V4 and V5 sockets as shown. To install it, line up the locating lugs on the face of the control with the small holes provided in the chassis and press control firmly into place against the chassis. When correctly installed, two spring tabs will snap open on the other side, holding the control securely in place as shown in Pictorial 2.
19. () Mount a 4-lug terminal post (20-311) near the large cut-out for the power transformer. Use 4-40 hardware (1).

20.  Install a 1/2" grommet (20-33) at hole A.
21.  Install two 1/4" grommets (20-210) at holes B and C.

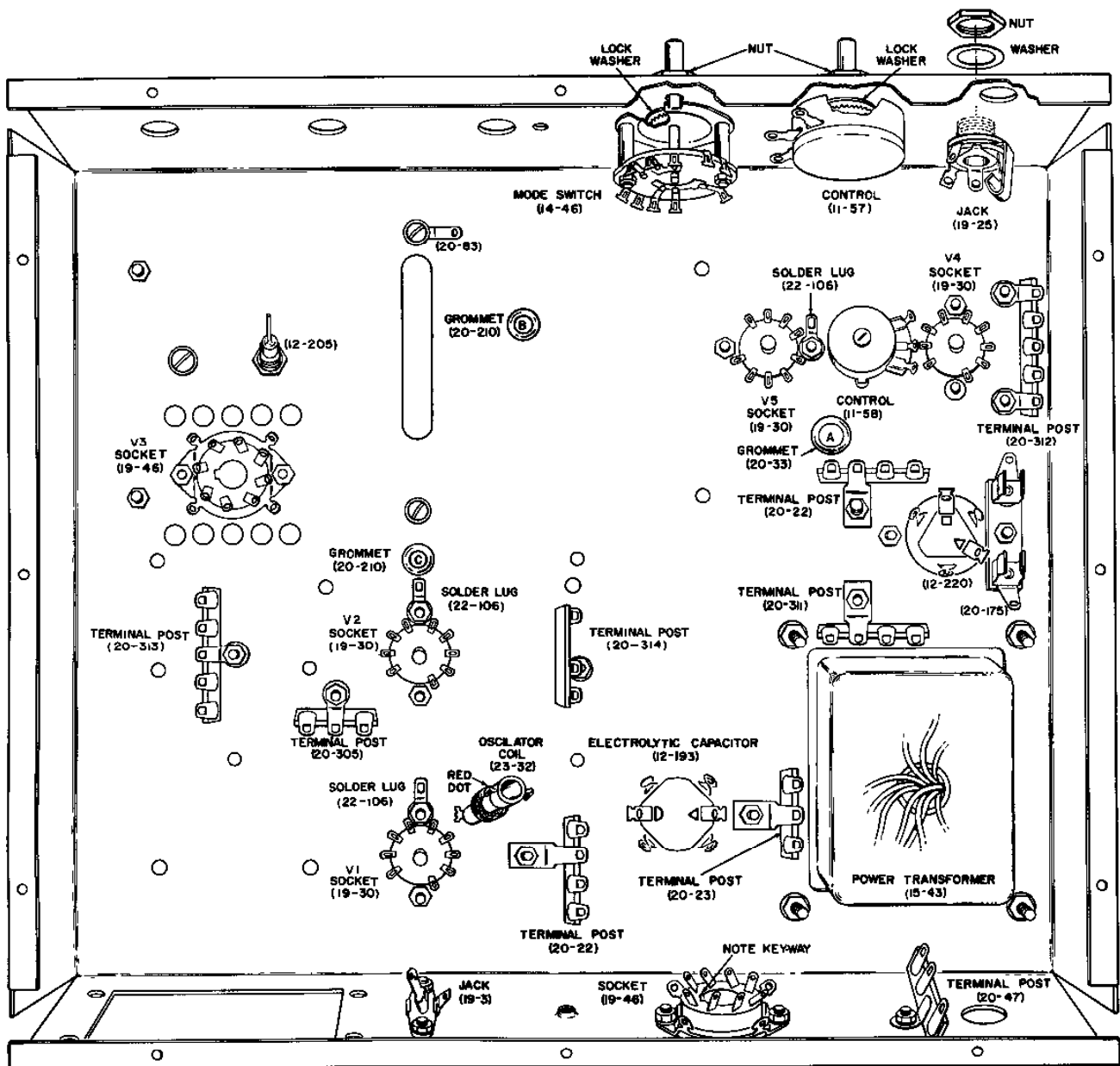

PICTORIAL 1

REFER TO PICTORIAL 2

22.  Select the following parts:
- Two Stand-off Insulators (20-309)
 - Two Dual Solder Lugs (20-100)
 - Two Cork Washers (22-140)
 - Four 8-32 x 1/4" Screws
 - Four #8 Lockwashers
 - One #8 Solder Lug

23. (✓) At hole D, install one stand-off insulator, dual solder lug, cork washer, and one #8 solder lug, using two 8-32 x 1/4" screws and two #8 lockwashers to secure the complete assembly as shown. Tighten screws firmly, but not excessively or the insulators may be damaged. At hole E, install one stand-off insulator, dual solder lug and cork washer, using two 8-32 x 1/4" screws and two #8 lockwashers to secure the complete assembly. Make sure that both of the dual solder lugs and the #8 solder lug are oriented as shown.
24. (✓) Install the electrolytic mounting wafer (20-75) and fuseholder (20-175) as shown. On one side, use a 4-40 x 3/8" screw (attach the fuseholder to this side), a #4 lockwasher and 4-40 hex nut. On the other side, use a 4-40 x 1/4" screw, #4 lockwasher and 4-40 hex nut. Be sure to orient the mounting wafer as shown.

REFER TO PICTORIALS 1 and 2

25. (✓) Install the 10-10 μ f 150 volt insulated electrolytic capacitor (12-220) on the mounting wafer. Orient the solder lugs (by means of the square and triangular cut-outs in the base) as shown in Pictorials 1 and 2. To mount securely, hold the capacitor firmly against the wafer (with the mounting lugs passed through the slots) and then twist each of the three mounting lugs (not solder lugs) 1/4 turn, using pliers.
26. (✓) Install a 40-40 μ f 450 volt electrolytic capacitor (12-193) to the left of the large cut-out in the chassis as shown in Pictorial 1. Orient the half-moon and triangular cut-outs in the base as shown. Use the same general mounting procedure as that given in the previous step, twisting each of the four mounting lugs 1/4 turn.
27. (✓) Install the feed-through capacitor (12-205) from the top of the chassis as shown in Pictorial 2, using the special 5/16" silver-plated nut provided. To install into the hole in the chassis, rock the capacitor from side to side slightly, exerting a downward pressure at the same time. Secure tightly from the underside of the chassis by means of the special 5/16" nut. When tightening the nut, make sure you do not damage the ceramic portion of the capacitor (ceramic material cracks quite easily).

REFER TO PICTORIAL 2

28. (✓) Mount the RF choke (23-39) and cork washer (22-140) as shown, using a 6-32 x 1/4" screw and #6 lockwasher. Leave the screw fairly loose in order to permit you to rotate the choke as necessary in the next step.
29. (✓) Referring to detail A, bend the terminating lead of the feed-through capacitor down in the direction of the hole in the lower lug of the choke. Twist the choke in the direction of the arrow, so that the capacitor lead passes through the hole. When most of the lead has passed through, bend it upward. Tighten the screw securing the choke (do not tighten excessively or damage to the ceramic portion of the choke may result).
30. (✓) Select the following parts: 6-32 x 3-3/4" bolt (22-144), fiber washer (22-143), 30 watt center-tapped 25K resistor (13-273), 4-lug terminal post (20-22), #6 lockwasher and 6-32 hex nut. Install these parts in the sequence shown in Pictorial 2, making sure the 30 watt resistor and terminal post are oriented as illustrated. Do not tighten bolt excessively or damage to the resistor may result.
31. (✓) Select the front section of the final amplifier shield (10-147). Attach two of the longer spade lugs (22-151) to the bottom edge of one side of the shield as shown (detail B), using a 6-32 x 1/4" screw, #6 lockwasher and 6-32 hex nut to secure each spade lug.
32. (✓) Install the variable tuning capacitor (12-198) on the shield as shown, using a 3/8" lockwasher and 3/8" hex nut to secure the capacitor. Keep the plates fully meshed at all times. Position the capacitor so that its lower edge lies parallel to the lower edge of the shield. Tighten securely in this position.
33. (✓) Install the shield on the chassis, allowing the spade lugs to pass through the holes in the chassis. Secure from the underside of the chassis by means of two #6 lockwashers and two 6-32 hex nuts.

REFER TO PICTORIAL 1

34. () Install the power transformer (15-43) in the large cut-out in the chassis. Mount the transformer in the position which allows the two black leads to reach the lower two lugs of the nearby terminal post on the rear apron. Secure the transformer firmly, using four 8-32 hex nuts and four #8 lockwashers.
35. () Install the oscillator coil (23-32) in the hole near V1. To install, press the coil firmly into place, allowing the spring tabs to snap open on the other side of the chassis. Be sure to orient the coil with the terminal lugs in the positions shown, the terminal with a red dot located at the left.

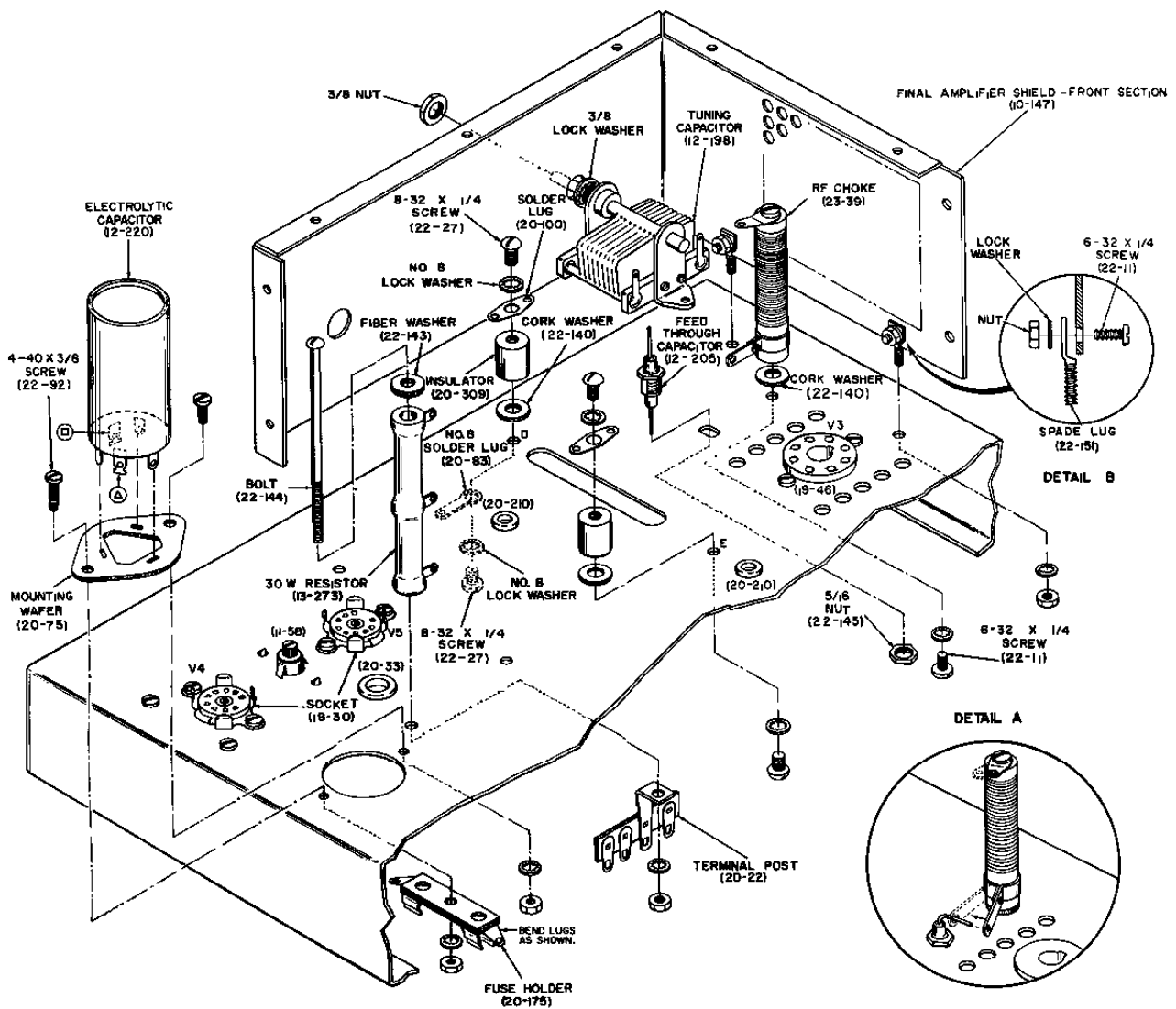

PICTORIAL 2

UNDERCHASSIS WIRING - I

LEAD DRESS

It is recommended that the wiring dress and parts layout shown in the pictorials be faithfully followed. The lead lengths specified in the instructions were carefully determined through the construction of a series of laboratory models and will enable you to follow the same arrangement without any difficulty.

REFER TO PICTORIAL 3

CAUTION: Two shield brackets will eventually be installed on either side of socket V2. The areas which will be occupied by these brackets have been shown in Pictorial 3 by means of broken lines. Be sure to keep all leads outside of these areas, dressing the leads as shown.

It will now be necessary to connect the free ends of the leads from the power transformer T1 to various terminals on the underside of the chassis. All leads have been pre-cut to the proper length and should reach their assigned terminals without difficulty. If you find that one of the leads is short however, tug gently on it with a pair of long-nose pliers -- some of the lead may be contained within the bell casing of the transformer.

36. (~) Connect one of the BLACK transformer leads to TP-1 lug 1 (NS).
 37. () Connect the other BLACK transformer lead to TP-1 lug 2 (NS).
 38. () Connect the WHITE transformer lead to C33 lug 2 (S-1).
 39. () Connect the longer of the two RED leads to C36 lug A (NS).
 40. (/) Connect the shorter RED lead to TP-2 lug 1 (NS).
 41. (~) Connect the WHITE/BLACK transformer lead to TP-7 lug 4 (NS).
 42. (/) Connect the YELLOW transformer lead to J-1 lug 7 (S-1).
 43. (~) Connect the BLUE transformer lead to TP-2 lug 3 (NS).
 44. (/) Connect both the GREEN/YELLOW and BLUE/YELLOW transformer leads to TP-2 lug 2 (S-2).
 45. (/) At socket V4, bend lugs 4, 5 and 8 against the center post as shown.
 46. (/) Cut a 2" length of BLACK lead. Connect it from TP-9 lug 5 (NS) to the center post of V4 socket (NS).
 47. (/) Cut a 1-3/4" length of BLACK lead. Connect it from R21 lug 3 (NS) to the center post of V4 socket. Solder all connections at the center post, using sufficient heat and solder to ensure a good electrical connection.
 48. (~) At socket V5, bend lug 8 against the center post. Cut a 2" length of bare wire. Using this wire, make a connection from the center post of socket V5 to SL-1, passing the wire through lug 4 of V5 socket as shown. Cut off excess wire, then solder the center post and lug 4 of V5 socket. Do not solder SL-1.
- NOTE:** Two sizes of yellow interconnecting lead have been supplied with this kit. One is a standard #22 lead, while the other is a heavier #18 lead. Use the heavier #18 lead only when specifically instructed to do so. In all other cases, use the standard size #22 lead.
49. (/) Cut a 3-1/2" length of YELLOW lead. Connect it from V4 lug 9 (S-1) to V5 lug 5 (NS).
 50. () Cut an 8" length of YELLOW lead. Connect one end to V5 lug 5 (NS). Feed the free end through grommet hole A and leave temporarily disconnected.
 51. (/) Cut a 8" length of YELLOW lead. Connect it from V5 lug 5 (S-3) to TP-2 lug 3 (NS).
 52. (/) Cut each lead of a 0.01 μ f 600 volt capacitor C32 to 3/4". Connect the end with the outside foil line to J-1 Lug G1 (S-1). Connect the other lead to TP-1 lug 1 (NS).

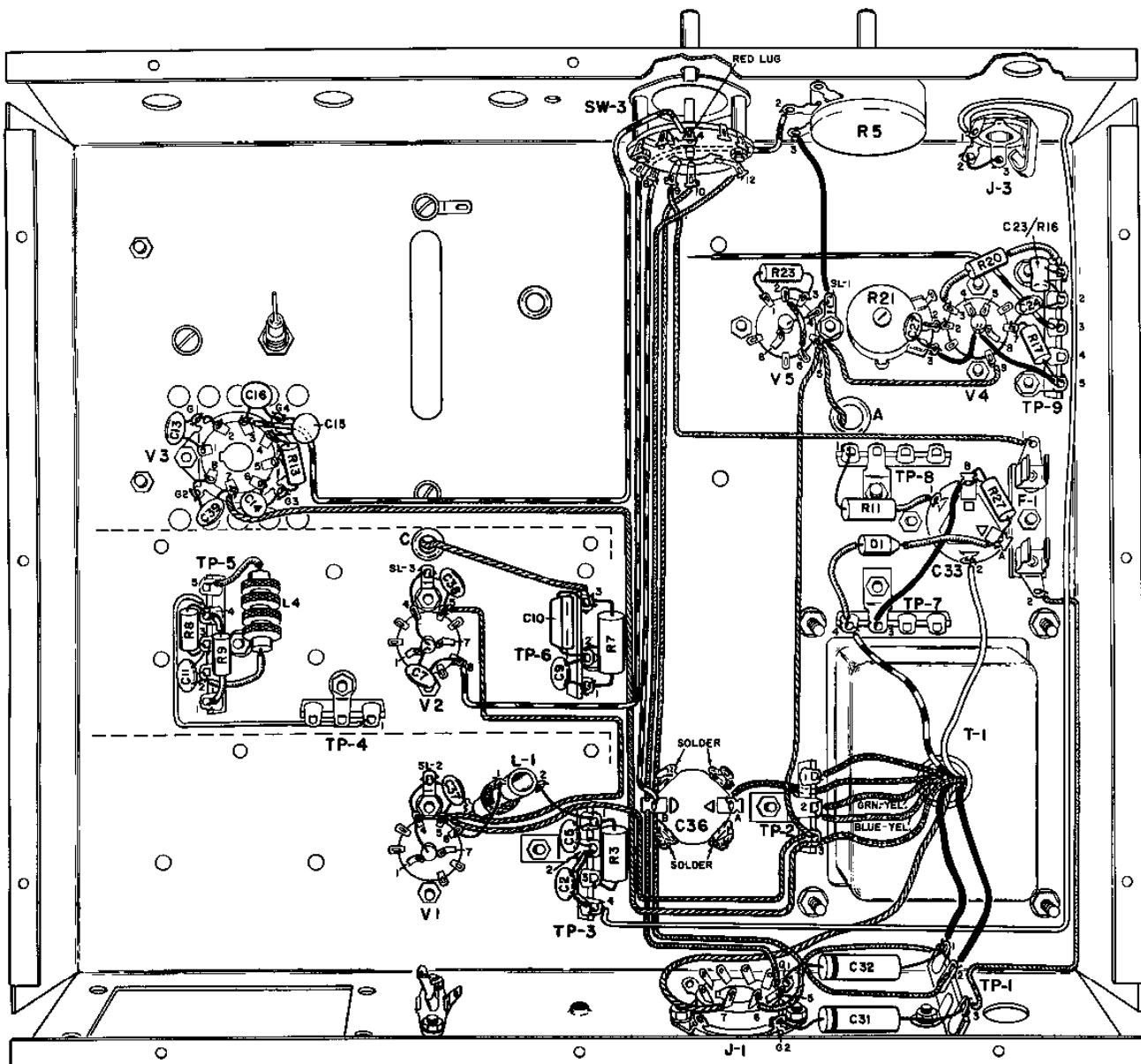

PICTORIAL 3

53. (✓) Cut each lead of a 0.01 μ f 600 volt capacitor C31 to 3/4". Connect the end with the outside foil line to J-1 lug G2 (S-1). Connect the other end to TP-1 lug 3 (NS).
54. () Cut a 4" length of GRAY lead. Connect it from J-1 lug 6 (S-1) to TP-1 lug 1 (NS).
55. (✓) Solder the four twisted mounting lugs of C36 to the chassis. Use sufficient heat and solder to ensure a good electrical connection to the chassis in each case.
56. (✓) Cut a 15" length of GRAY lead. Connect it from TP-1 lug 2 (S-2) to SW-3 lug 10 (S-1). Dress the lead as shown. Make sure lug 10 of the switch is kept well away from the chassis.
57. (✓) Cut a 9-1/4" length of GRAY lead. Connect it from TP-1 lug 3 (NS) to F-1 lug 2 (S-1).
58. () Cut a 9" length of GRAY lead. Connect it from F-1 lug 1 (S-1) to SW-3 lug 9 (S-1). Dress exactly as shown.

59. (✓) Cut a 15-1/2" length of GRAY lead. Connect it from SW-3 lug 12 (S-1) to J-1 lug 5 (S-1). Dress as shown.
60. (✓) Cut a 9" length of RED/WHITE lead. Connect it from C36 lug B (NS) to SW-3 lug 8 (S-1).
61. (✓) Cut a 20-1/4" length of WHITE lead. Connect it from TP-3 lug 4 (NS) to J-3 lug 1 (S-1). Route the lead around the chassis as shown, passing it beneath the black transformer leads.
62. (✓) Connect a short length of bare wire from J-3 lug 2 (S-1) to J-3 lug 3 (S-1).
63. () Cut a 2-3/4" length of BLACK lead. Connect it from R5 lug 3 (S-1) to SL-1 (S-2).
64. (✓) Cut a 16-1/2" length of heavy YELLOW lead (#18). Connect one end to TP-2 lug 3 (NS). Route the lead exactly as shown (using long-nose pliers to make the necessary bends). Connect the other end to V3 lug 7 (use the lower hole in the lug). Solder the connection at lug 7, but leave the upper hole clear.
65. (✓) Connect a 0.005 μ f 20% ceramic disc capacitor C39 from V3 lug 7 (upper hole) to V3 lug G2. Solder lug 7 (S-2) and G2 (NS).
66. (✓) Connect a short length of bare wire between V3 lug 8 (S-1) and V3 lug G2 (S-2).
67. (✓) Connect a short length of bare wire between V3 lug 2 (S-1) and V3 lug G1 (NS).
68. (✓) At socket V1, bend lugs 1 and 7 against the center post. Connect a short length of bare wire from SL-2 (NS), through V1 lug 4, to the center post (NS). Solder V1 lug 4 (S-1).
69. (✓) Cut a 8" length of YELLOW lead. Connect it from V1 lug 5 (NS) to TP-2 lug 3 (S-4).
70. (✓) At socket V2, bend lugs 1 and 7 against the center post. Connect a short length of bare wire from SL-3 (NS), through V2 lug 4, to the center post (NS). Solder V2 lug 4 (S-1).
71. () Cut a 9" length of YELLOW lead. Connect it from V2 lug 5 (NS) to V1 lug 5 (NS).
72. () Connect a 0.005 μ f 20% ceramic disc capacitor C37 from V1 lug 5 (S-3) to SL-2 (S-2). When installing the capacitor, keep the leads as short as possible.
73. (✓) Connect a 0.005 μ f 20% ceramic disc capacitor C38 from V2 lug 5 (S-2) to SL-3 (S-2). Keep leads as short as possible.
74. (✓) Cut a 13-1/2" length of RED/WHITE lead. Connect it from SW-3 lug 4 (S-1) to V3 lug 3 (NS).
75. (✓) Connect a 0.005 μ f 20% ceramic disc capacitor C16 from V3 lug 3 (S-2) to V3 lug G4 (NS). Keep leads short.
76. (✓) Cut a 14-1/4" length of RED/WHITE lead. Connect it from V2 lug 8 (NS) to R5 lug 2 (S-1). Dress the lead as shown.
77. (✓) Connect a 0.005 μ f 20% ceramic disc capacitor C7 from the center post of V2 to lug 8 of V2. Keep capacitor leads short. Solder V2 lug 8 (S-2) and all connections at the center post.
78. (✓) Connect a 0.005 μ f 20% ceramic disc capacitor C13 from V3 lug 1 (S-1) to V3 lug G1 (S-2). Keep capacitor leads short.
79. (✓) Connect a 0.005 μ f 20% ceramic disc capacitor C14 from V3 lug 6 (S-1) to V3 lug G3 (NS). Keep capacitor leads short.
80. (✓) Connect a 0.005 μ f 20% ceramic disc capacitor C15 from V3 lug 4 (NS) to V3 lug G4 (S-2). Keep capacitor leads short.
81. (✓) Cut each lead of a 10 ohm 1/2 watt resistor (brown, black, black, silver) R13 to 1-3/4". Connect it from V3 lug 4 (NS) to V3 lug G3 (S-2).
82. (✓) Cut a 7-5/8" length of heavy YELLOW lead (#18). Prepare this lead exactly as shown in Figure 1.

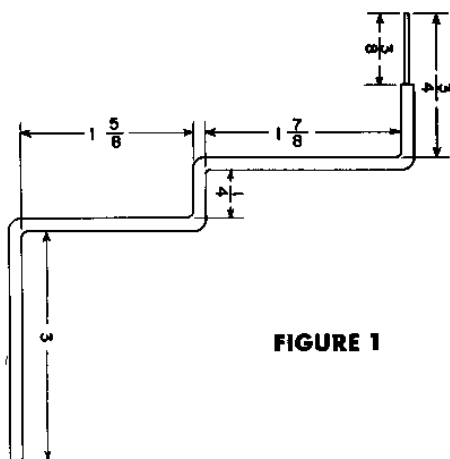

FIGURE 1

83. (✓) Install the prepared lead (which will act as the neutralizing stub) as follows:

Pass the 3/8" stripped end through grommet hole C from the topside of the chassis. Connect the stripped end to TP-6 lug 3 (NS). If properly prepared, the lead should lie close to the chassis on the underside as shown in Pictorial 3. On the topside, the lead should take up the position shown in Pictorial 4, with the last 3" of the lead about 5/8" to 3/4" away from the edge of the tube socket and perpendicular to the chassis.

84. (✓) Cut each lead of a 120 μf 1500 volt molded mica capacitor C10 (marked 12-203) to 3/4". Connect from TP-6 lug 2 (NS) to TP-6 lug 3 (NS). Dress the capacitor close to the post, as shown.
85. (✓) Cut each lead of 0.005 μf 20% ceramic disc capacitor C9 to 1/2". Connect from TP-6 lug 1 (NS) to TP-6 lug 2 (S-2). Dress as shown.
86. (✓) Cut each lead of a 1.5K ohm 2 watt resistor (brown, green, red, silver) R7 to 1". Connect from TP-6 lug 1 (NS) to TP-6 lug 3 (NS). Install as shown, keeping the resistor well away from the terminal post.
87. (✓) Cut a 5-1/2" length of WHITE lead. Connect it from TP-5 lug 4 (NS) to TP-4 lug 1 (NS).
88. (✓) Cut each lead of a 0.005 μf 20% ceramic disc capacitor C11 to 1/2". Connect it from TP-5 lug 2 (NS) to TP-5 lug 3 (NS).
89. (✓) Cut each lead of a 10K ohm 1/2 watt resistor (brown, black, orange, silver) R8 to 1/2". Connect it from TP-5 lug 4 (NS) to TP-5 lug 3 (S-2).
90. (✓) Cut each lead of a 4.7K ohm 1/2 watt resistor (yellow, violet, red, silver) R9 to 3/4". Slip a 1/2" length of sleeving over each lead. Connect it from TP-5 lug 1 (NS) to TP-5 lug 4 (S-3).
91. (✓) Cut each lead of a 1.1 mh RF choke (23-38) L-4 to 7/8". Slip a 1/2" length of sleeving over each lead. Connect it from TP-5 lug 2 (NS) to TP-5 lug 5 (NS). Dress as shown.
92. (✓) Cut each lead of a 0.005 μf 20% ceramic disc capacitor C2 to 3/4". Slip a 3/8" length of sleeving over each lead. Connect it from TP-3 lug 2 (NS) to TP-3 lug 4 (NS).
93. (✓) Cut each lead of a 0.005 μf 20% ceramic disc capacitor C5 to 1/2". Connect it from TP-3 lug 1 (NS) to TP-3 lug 2 (S-2).
94. (✓) Cut each lead of a 1.5K ohm 2 watt resistor (brown, green, red, silver) R3 to 3/4". Bending the leads as shown, connect the resistor from TP-3 lug 3 (NS) to TP-3 lug 1 (NS). Dress down close to the terminal post.
95. (✓) Cut a 2" length of bare wire. Make a connection from L1 lug 2 (S-1) to TP-3 lug 1 (S-3). Keep the wire between these two points as short as possible, removing any excess, as necessary.
96. (✓) Cut a 2" length of bare wire. Make a connection from V1 lug 6 (S-1) to L1 lug 1 (NS). Keep wire between these points as short as possible, removing any surplus wire, as necessary.
97. (✓) Cut a 3-1/4" length of BLACK lead. Connect it from TP-7 lug 3 (S-1) to C33 lug B (NS).
98. (✓) Select the silicon diode D1 (marked 1724). Slip a 1" length of sleeving over each lead. Orienting the diode as shown, connect it from TP-7 lug 4 (S-2) to C33 lug A (NS). Take care not to overheat the diode or it may be damaged.

99. (✓) Cut each lead of a 330 ohm 1/2 watt resistor (orange, orange, brown, silver) R27 to 5/8". Connect it from C33 lug A (S-2) to C33 lug B (S-2).
100. (✓) Cut one lead of an 18K ohm 1 watt resistor (brown, gray, orange, silver) R11 to 3/4". Cut the other lead to 1-1/8". Slip a 1/2" length of sleeving over the shorter lead. Connect the end without sleeving to TP-8 lug 1 (NS) and the covered lead to C33 lug 1 (S-1). Make sure the use of excess solder does not cause lug 1 of C33 to short to the chassis.
101. (✓) Cut each lead of a 470 µf 10% ceramic disc capacitor C27 to 1/2". Slip one lead of the capacitor through R21 lug 2 and connect it to V4 lug 2. Connect the other lead to R21 lug 3. Trim off excess wire and then solder V4 lug 2 (S-1), R21 lug 2 (S-1), and R21 lug 3 (S-2).
102. (✓) Cut a 6" length of RED/WHITE lead. Connect one end to TP-9 lug 3 (NS). Pass the other end of the lead beneath the black lead going to SL-1, and leave temporarily disconnected.
103. (✓) Select the Tube-R-Kap (marked C100 R560K). This is a combined resistor and capacitor, C23 and R16. Cut each lead to 1/2" and connect it from TP-9 lug 1 (NS) to TP-9 lug 2 (NS). Position as shown.
104. (✓) Cut each lead of a 4.7K ohm 1/2 watt resistor (yellow, violet, red, silver) R20 to 3/4". Slip a 1/2" length of sleeving over each lead. Connect it from V4 lug 3 (S-1) to TP-9 lug 1 (S-2).
105. (✓) Cut one lead of a 2.2 megohm 1/2 watt resistor (red, red, green, silver) R17 to 3/4" and the other lead to 1/2". Connect the 3/4" lead to TP-9 lug 5 (S-2). Connect the 1/2" lead to V4 lug 7 (NS). Dress the resistor down, close to the chassis.
106. (✓) Cut each lead of a 0.002 µf (or 2000 µf) ceramic disc capacitor C24 to 1/2". Connect it from V4 lug 7 (S-2) to TP-9 lug 2 (NS).
107. (✓) Cut a 2" length of RED/WHITE lead. Strip the normal 1/4" of insulation from one end, but at the other, strip off 1/2". Pass the 1/2" end through V5 lug 2 (NS) and connect to lug 3 (NS). Connect the other end of the lead to V5 lug 6 (S-1). Solder V5 lug 2 (S-1). Keep the lead away from the center post of the socket as shown.
108. (✓) Cut each lead of a 1.5 megohm 1/2 watt resistor (brown, green, green, silver) R23 to 1/2". Connect it from V5 lug 1 (NS) to V5 lug 3 (S-2).

TOPCHASSIS ASSEMBLY - I

REFER TO PICTORIAL 4

109. (✓) Solder the connection at L5 lug 2 (S-1). Cut off any surplus capacitor (C18) lead.
110. (✓) Select a 0.001 µf 2000 volt molded mica capacitor C19 (marked 12-202). Cut one lead to 1", and the other to 3/4". Connect the 3/4" end to C20 lug 1 (S-1), and the 1" end to L5 lug 1 (NS). Dress the capacitor away from L5 (at least 1/8").
111. (✓) Strip off the insulation from a 2-1/4" length of heavy YELLOW lead (#18). Connect this bare wire from P2 lug 1 (S-1) to C20 lug 2 (S-1).
112. (✓) Strip off the insulation from a 3" length of heavy YELLOW lead (#18). Connect one end of this bare wire to P2 lug 2 (NS). Pass the other end through grommet hole B and leave temporarily disconnected.
113. () Select L6, the Pi-net tank coil (23-34). Install the coil over the large slot in the chassis, passing the two short end leads through P2 lug 2 and P1 lug 1, and the four long leads through the slot as shown. The bottom of the coil should be raised about 1/2" above the dual solder lugs, and positioned so that it lies parallel to the chassis. Solder P2 lug 2 (S-2) but merely crimp the lead at P1 lug 1 (NS). Cut off any excess lead length at these two points.
114. (✓) Cut a 4-1/2" length of heavy YELLOW lead (#18). Connect one end to P1 lug 2 (NS). Pass the other end through the slot in the chassis, and leave temporarily disconnected.
115. (✓) Strip off the insulation from a 6-3/4" length of heavy YELLOW lead (#18). Connect one end of this bare wire to P1 lug 2 (S-2). Leave the other end temporarily disconnected.
116. () Put the chassis to one side temporarily.

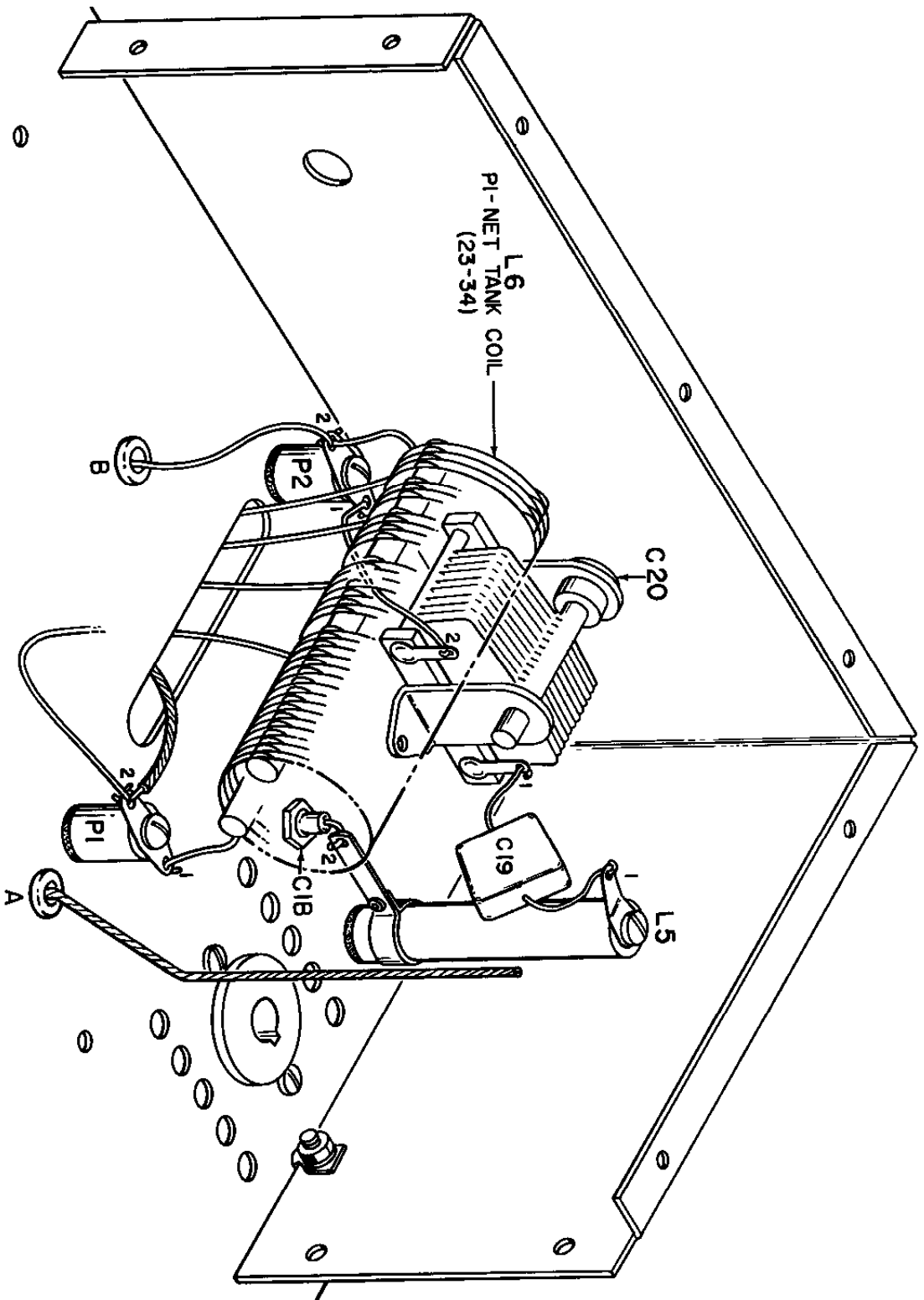

PICTORIAL 4

BAND SWITCH AND COIL ASSEMBLY

REFER TO FIGURE 2

117. (✓) Select the shield bracket (10-151).
118. (✓) Select the BAND switch assembly (14-45). Locate the rear wafer section and its associated hardware (these parts will be found in a plastic bag).
119. (✓) Mount the rear wafer to the shield bracket as shown. Use the two spacers, two screws, two split lockwashers and two hex nuts (this hardware is supplied with the rear wafer). Be sure to orient the wafer exactly as shown.

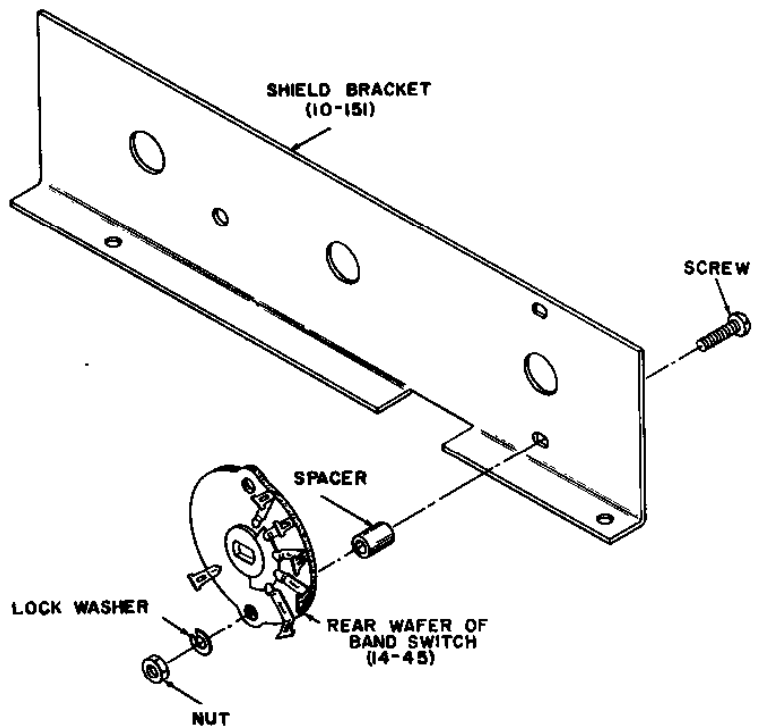

FIGURE 2

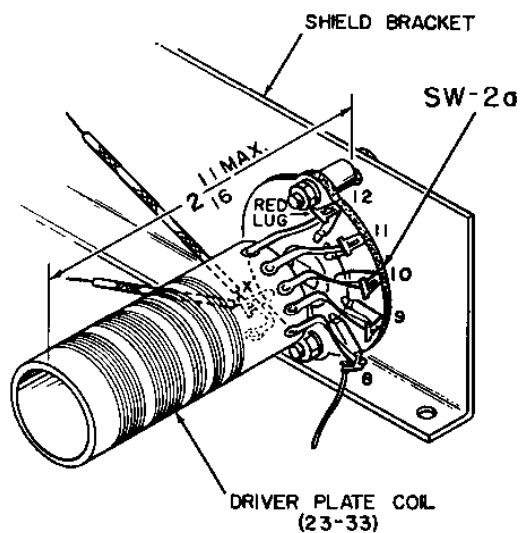
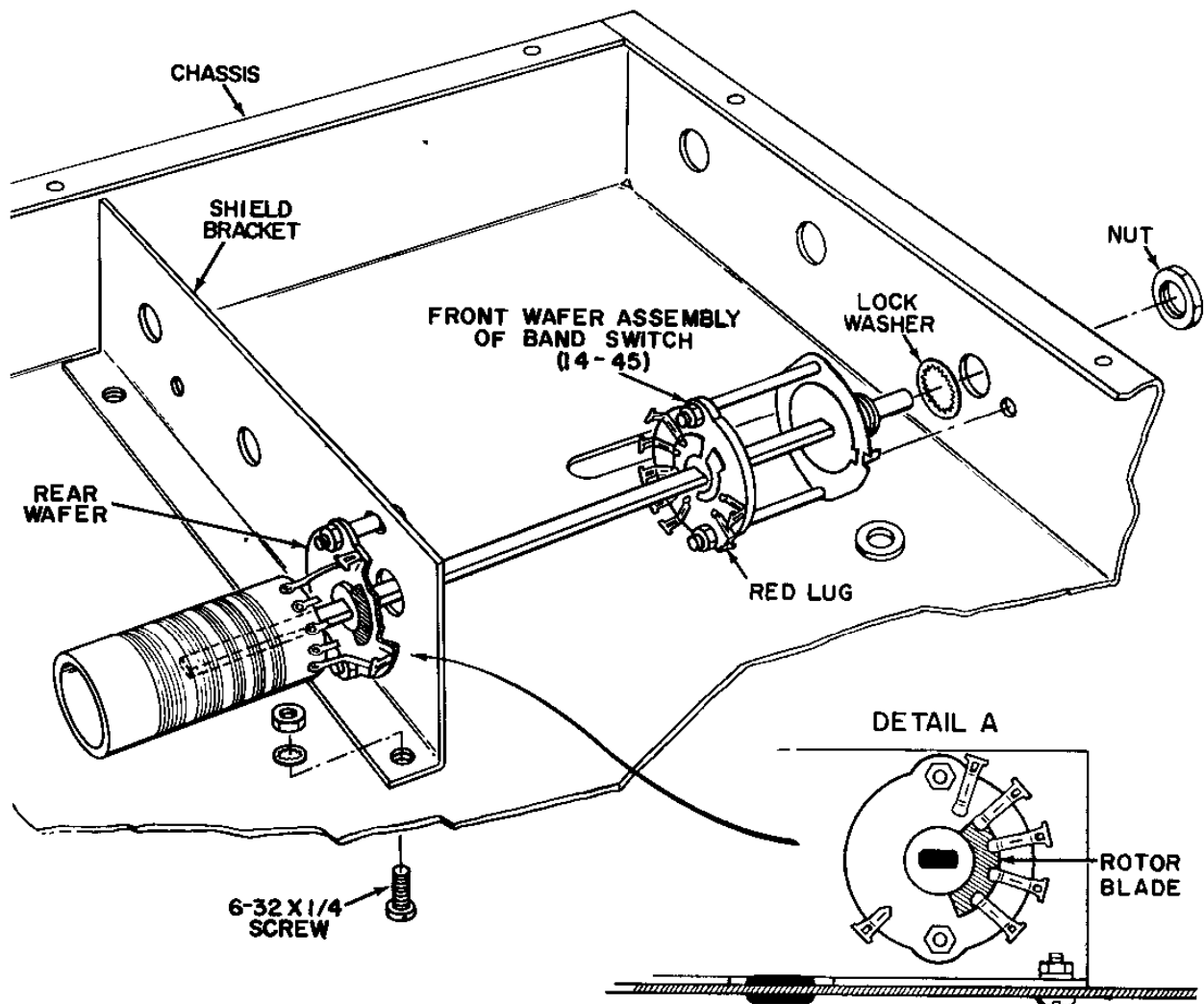

FIGURE 3

REFER TO FIGURE 3

120. (✓) Select the Driver Plate Coil (23-33). Twist each coil tab approximately 90 degrees as shown. Install the coil on the rear wafer (SW-2a), allowing each tab to pass through a corresponding switch lug as shown. Position the coil so that it occupies a central position on the wafer, and leave coil tabs full length temporarily. Make sure the distance between the end of the coil and the bracket does not exceed 2-11/16" (as indicated).
121. (✓) Solder lugs 12, 11, 10 and 9 of switch SW-2a. Cut off surplus wire from these terminals only.
122. () Cut a 2-1/4" length of RED/WHITE lead. Connect one end to dummy lug X (NS) on SW-2a. Leave the other end temporarily disconnected.
123. (✓) Cut a 1-1/2" length of RED/WHITE lead. Connect one end to dummy lug X (S-3) of SW-2a. Cut off surplus wire (from the coil) at this lug. Leave the other end of the red/white lead temporarily disconnected.
124. (✓) Cut a 1-1/2" length of bare wire. Connect one end to SW-2a lug 8 (S-2) and leave the other end temporarily disconnected. Trim off surplus coil tab at lug 8.



PICTORIAL 5

REFER TO PICTORIAL 5

125. (✓) Select the front wafer assembly of the BAND switch (14-45).
126. (✓) Insert the shaft of the front wafer assembly into the slot in the rear wafer and rotate its rotor blade to the position shown in detail A. Then withdraw the shaft carefully, making sure the position of the rotor blade in the rear wafer is not changed.
127. (✓) Rotate the shaft of the front wafer assembly until its rotor blades assume the positions shown in the main illustration. Note the position of the red lug also.
128. (✓) Orient the front wafer assembly as shown and then, carefully, insert the shaft into the slot in the rear wafer. Allow a portion of the shaft to enter the coil as shown.
129. (✓) Lower the shield bracket (with attached switch assembly) into place on the underside of the main chassis. Do not attempt to secure the bracket with hardware yet. Place a 3/8" lock-washer over the shaft of the front wafer assembly (knob end), then guide the shaft into its assigned hole in the front apron of the chassis. Secure with a 3/8" hex nut, making sure the locating tab on the switch assembly enters the small hole provided for it in the chassis. The nut should only be finger-tight -- it must later be removed for mounting of the escutcheon.
130. (✓) Secure the shield bracket to the chassis by means of two 6-32 x 1/4" screws, two #6 lock-washers and two 6-32 hex nuts.

TOPCHASSIS ASSEMBLY - II

REFER TO PICTORIAL 6

131. (✓) Select the Final amplifier shield, rear section (10-148), two 6-32 x 1/4" spade lugs (22-156), two 6-32 x 7/16" spade lugs (22-151), four 6-32 x 1/4" screws, four #6 lockwashers, and four 6-32 hex nuts.
132. (✓) Attach two 6-32 x 1/4" (shorter) spade lugs to the rear side of the shield as shown, using 6-32 hardware (2). Attach two 6-32 x 7/16" (longer) spade lugs to the other side of the shield, using 6-32 hardware (2).
133. (✓) Select the following parts: 3-gang variable capacitor (12-199), three 6-32 x 3/16" screws, three #6 split lockwashers, panel bushing (22-90), four 6-32 hex nuts, four #6 lockwashers, four #8 x 3/8" sheet metal screws, 2-lug terminal post (20-20), and a 1-lug terminal post (20-74).
134. (✓) Attach the rear of the variable (loading) capacitor to the shield, using three 6-32 x 3/16" screws and three #6 split lockwashers. Note that there are three tapped holes in the rear of the capacitor for this purpose.
135. (✓) Temporarily loosen the two nuts securing the previously installed final amplifier shield (front section).
136. (✓) Remove the 3/8" hex nut from the panel bushing and place the nut over the shaft of the variable capacitor. Carefully lower the rear shield onto the chassis as shown, guiding the capacitor shaft forward through the hole in the front shield and then allowing the studs to pass through the corresponding holes (H, I, J and K) in the chassis.
137. (✓) Place a small amount of light grease or vaseline on the inside surface of the panel bushing. Slip the bushing over the loading capacitor shaft and into the hole in the front shield. Secure the bushing to the shield by means of the hex nut.
138. (✓) On the underside of the chassis, install a #6 lockwasher and 6-32 hex nut on each stud at holes H and I. The nuts should be finger-tight only.
139. (✓) Fasten the rear shield to the front shield by means of four #8 x 3/8" sheet metal screws.
140. (✓) On the underside of the chassis, install the 1-lug terminal post on the stud at hole J, using a 6-32 hex nut and #6 lockwasher. Place the washer between the chassis and the foot of the terminal post. Before tightening the nut, make sure the post is positioned as shown (also see Pictorial 7 for an underchassis view).
141. (✓) Similarly, install the 2-lug terminal post on the stud at hole K, positioning it as shown.
142. (✓) Tighten all remaining hex nuts securing the front and rear final amplifier shields to the chassis. Use care when tightening the nut at location H in order to avoid damaging switch SW-2a.

REFER TO FIGURE 4

143. (✓) Select the DRIVE TUNE capacitor (12-197), panel bushing (22-90), one 3/8" lockwasher, and one 3/8" hex nut.

Place the 3/8" lockwasher over the shaft of the capacitor, then pass the shaft through its assigned hole in the shield bracket on the underside of the chassis. Slip a 3/8" hex nut over the shaft; remove the hex nut from the panel bushing and slip this nut over the shaft. Orienting the capacitor as shown, guide the shaft through the hole in the front apron of the chassis. Secure the capacitor to the shield bracket using one of the hex nuts. Slip the panel bushing over the shaft and into the chassis hole, securing (finger-tight only) with the remaining hex nut.

NOTE: Before installing the panel bushing, apply a small amount of light grease or vaseline to its inside surface.

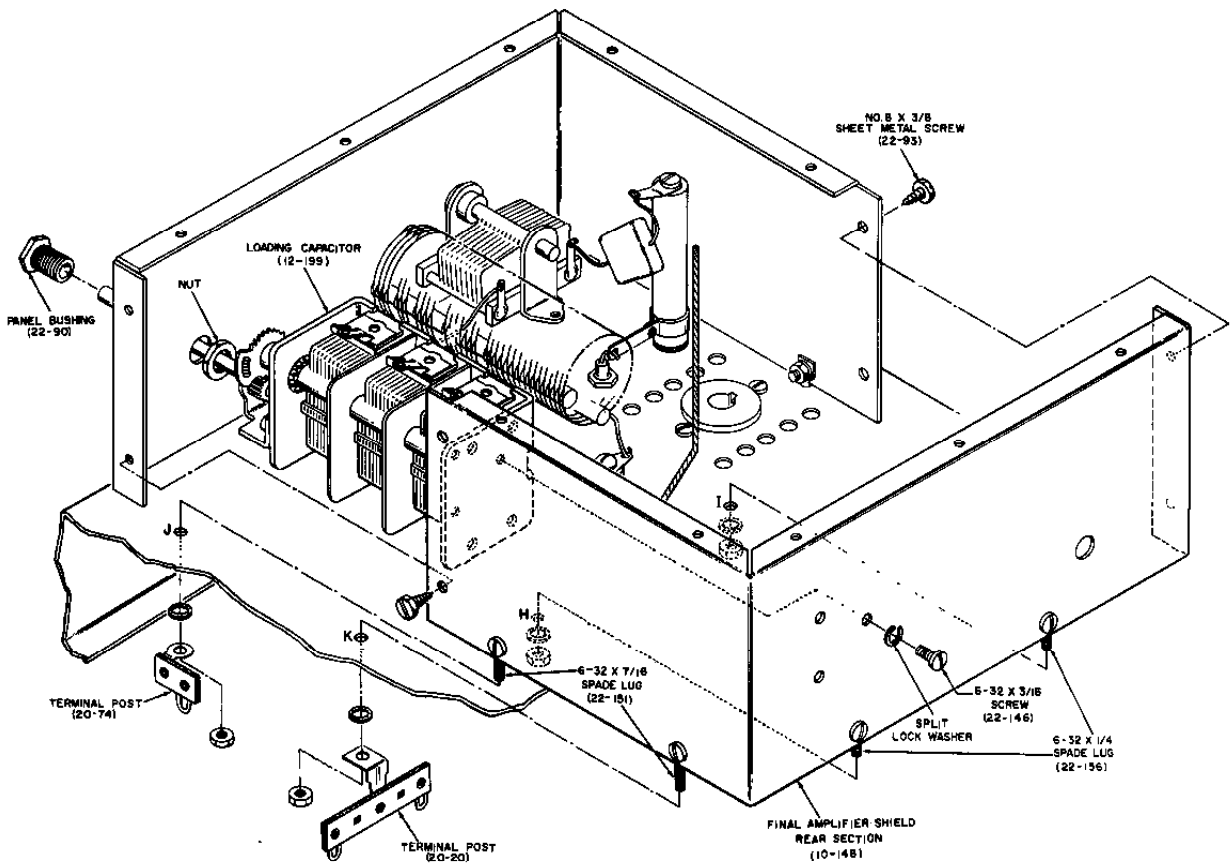

PICTORIAL 6

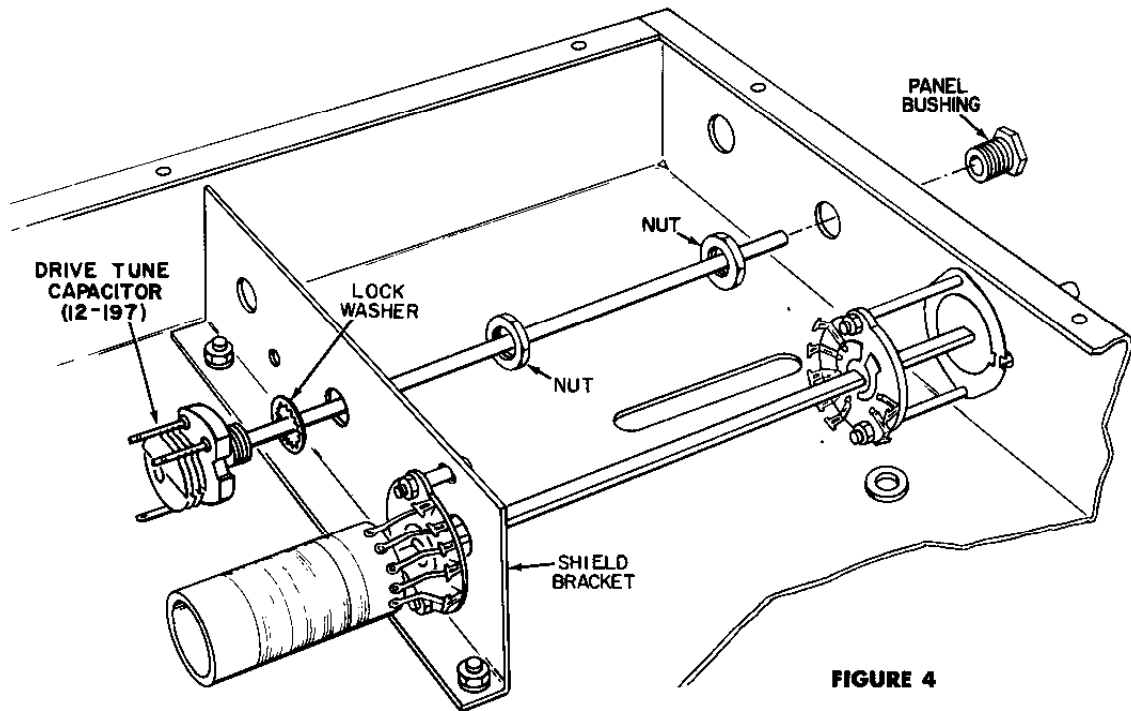

FIGURE 4

UNDERCHASSIS WIRING— II

REFER TO PICTORIAL 7

144. (✓) Locate the bare wire coming from SW-2a lug 8, and connect the free end to TP-6 lug 3 (S-4).
145. (✓) Locate the shorter of the two red/white leads coming from dummy lug X of SW-2a, and connect the free end to V2 lug 6 (S-1).
146. (✓) Connect the remaining red/white lead from lug X of SW-2a to C8 lug 2 (S-1).
147. () Connect the final amplifier coil leads to switch SW-2b as indicated below, using black vinyl sleeving and trimming each lead to a length necessary for it to pass through (not crimped to) its assigned lug on the switch. Keep the leads well apart from each other, and do not allow any of them to touch the edges of the large slot in the chassis.

<u>Coil Lead</u>	<u>Connect to switch lug</u>
1	11 (S-1)
2	10 (S-1)
3	9 (S-1)
4	8 (S-1)

148. (✓) Connect the free end of the yellow lead (emerging from the large slot) to SW-2b lug 7 (S-1).
149. (✓) Connect the free end of bare wire coming from grommet hole B to SW-2b lug 1 (S-1). Trim off any surplus wire. Make sure the switch lug is not damaged during this operation. Also, keep the wire clear of the chassis.
150. (✓) Cut each lead of a 68 μf 3 KV ceramic disc capacitor C21 to 1". Slip a 3/4" length of yellow sleeving over one lead and connect it to SW-2b lug 2 (S-1). Connect the other end to SL-4 (S-1). Position the capacitor as shown, making sure, however, that it does not come into contact with the shaft of the switch.
151. (✓) Connect the free end of the red/white lead coming from TP-9 lug 3 to TP-12 lug 1 (NS).
152. (✓) Cut a 11-1/4" length of GRAY lead. Connect it from TP-2 lug 1 (S-2) to SW-3 lug 1 (S-1).
153. (✓) Cut a 8" length of GRAY lead. Connect it from TP-8 lug 3 (NS) to SW-3 lug 2 (S-1).
154. (✓) Cut one lead of a 4.7K ohm 1/2 watt resistor (yellow, violet, red, silver) R15 to 1-1/4". Slip a 1" length of yellow sleeving over this lead and connect it to TP-9 lug 2 (S-3). Leave the other lead (full length) temporarily disconnected.
155. (✓) Cut each lead of a 47K ohm 1/2 watt resistor (yellow, violet, orange, silver) R14 to 1/2". Connect it from TP-9 lug 3 (S-2) to TP-9 lug 4 (NS).
156. (✓) Cut each lead of a 470K ohm 1/2 watt resistor (yellow, violet, yellow, silver) R18 to 5/8". Connect it from TP-9 lug 4 (NS) to V4 lug 6 (NS). Bend the lead going to V4 lug 6 at right angles to avoid a possible short circuit to lug 7 of the tube.
157. (✓) Cut each lead of a 0.005 μf 400 volt molded capacitor C26 to 3/4". Slip a 1/2" length of yellow sleeving over each lead. Connect the outside foil end (marked with a line) to V4 lug 6 (S-2), and the other lead to R21 lug 1 (S-1).
158. (✓) Cut one lead of a 470K ohm 1/2 watt resistor (yellow, violet, yellow, silver) R19 to 3/4". Cut the other lead to 5/8". Connect the 5/8" end to V4 lug 1 (NS), and the 3/4" end to TP-9 lug 4 (NS).
159. (✓) Cut one lead of a 22 megohm 1/2 watt resistor (red, red, blue, silver) R22 to 5/8". Cut the other lead to 3/4". Connect the 5/8" end to V5 lug 7 (NS), and the 3/4" end to TP-9 lug 4 (NS).
160. (✓) Cut each lead of a 0.005 μf 400 volt molded capacitor C28 to 1". Slip a 3/4" length of sleeving over each lead. Connect the outside foil end (marked with a line) to V4 lug 1 (S-2) and the other end to V5 lug 7 (S-2).

161. (↘) Cut a 3-1/2" length of RED/WHITE lead. Connect it from SW-3 lug 7 (S-1) to TP-12 lug 1 (NS).
162. (↘) Cut a 9" length of RED/WHITE lead. Connect it from TP-12 lug 1 (NS) to TP-6 lug 1 (NS).
163. (↘) Cut a 5-3/4" length of RED/WHITE lead. Connect it from TP-6 lug 1 (S-4) to TP-3 lug 3 (NS).
164. (↘) Cut each lead of a 12K ohm 2 watt resistor (brown, red, orange, silver) R26 to 3/4". Pass one lead through SW-3 lug 6 and solder (S-1). Connect the other lead to TP-12 lug 1 (NS).
165. (↘) Cut each lead of a 6.8K ohm 2 watt resistor (blue, gray, red, silver) R6 to 3/4". Connect it from R5 lug 1 (S-1) to TP-12 lug 1 (S-5).
166. (↘) Cut a 5-1/2" length of RED lead (#22 wire with heavy insulation). Connect it from V5 lug 1 (S-2) to TP-13 lug 2 (NS).

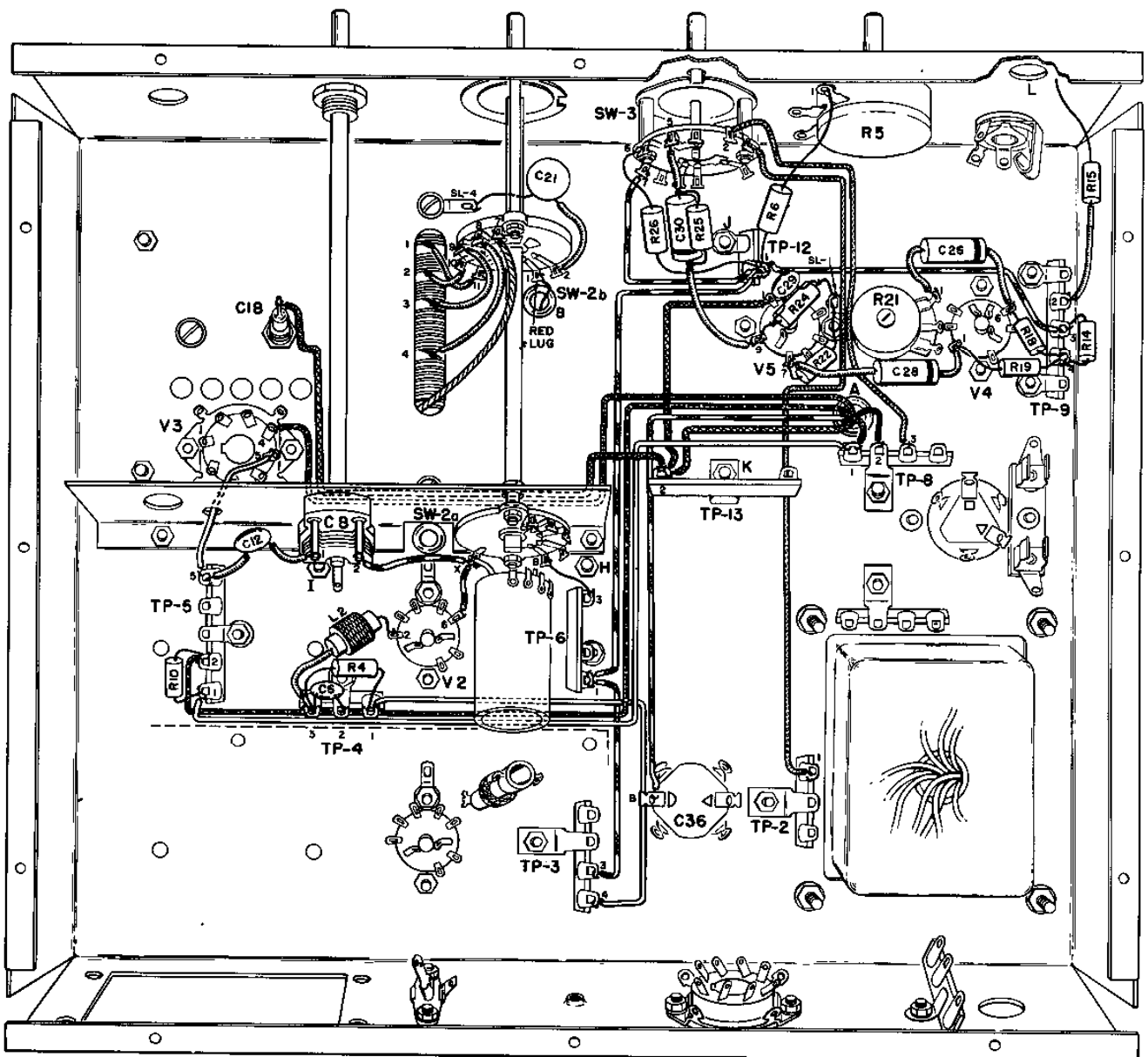

PICTORIAL 7

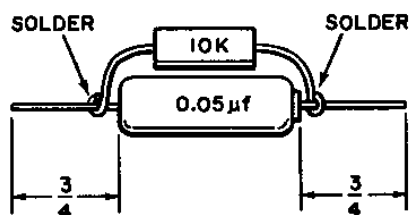

FIGURE 5

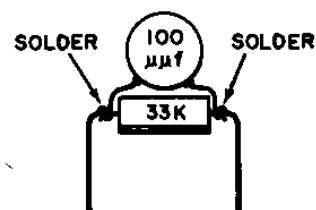

FIGURE 6

167. (✓) Select a 0.05 μf 400 volt molded capacitor C30 and a 10K ohm 2 watt resistor (brown, black, orange, silver) R25. Prepare these two components as shown in Figure 5. First, wrap the leads of the resistor around those of the capacitor. After cutting off surplus resistor lead, solder each wrap carefully. Trim each capacitor lead to $\frac{3}{4}$ " in length. Slip a $\frac{1}{2}$ " length of yellow sleeving over each lead and connect the resistor/capacitor combination between SW-3 lug 5 (S-1) and V5 lug 9 (NS). Be sure to connect the outside foil end (line) to V5 lug 9.
168. (✓) Select a 33K ohm 1 watt resistor (orange, orange, orange, silver) R24 and a 100 μf 10% ceramic disc C29. Cut the resistor leads to 1" in length, then install the capacitor across the resistor as shown in Figure 6 making two turns of the capacitor lead and then removing surplus wire. Bend the resistor leads as shown.
- Connect the resistor/capacitor combination from V5 lug 9 (S-2) to SL-1 (S-4). Do not attempt to crimp the lead at V5 lug 9 -- simply pass the lead through the lug and solder. Make sure there will be no chance of the capacitor coming into contact with the bottom plate (when installed later).
169. (✓) Cut a 3- $\frac{1}{4}$ " length of BLACK lead. Connect one end to TP-8 lug 2 (NS). Pass the free end through grommet hole A and leave temporarily disconnected.
170. (✓) Cut a 11- $\frac{1}{2}$ " length of RED/WHITE lead. Connect one end to C36 lug B (NS). Route the lead as shown, and pass the free end through grommet hole A, leaving this end temporarily disconnected.
171. (✓) Cut a 8- $\frac{1}{4}$ " length of RED lead (#22 wire with heavy insulation). Connect one end to TP-13 lug 2 (NS). Pass the free end through grommet hole A and leave temporarily disconnected.
172. () Cut an 8- $\frac{3}{4}$ " length of WHITE lead. Connect it from TP-4 lug 1 (NS) to TP-3 lug 4 (NS). Dress exactly as shown.
173. (✓) Cut a 19" length of BLUE lead. Connect one end to TP-5 lug 2 (NS). Route the lead as shown and pass the free end through grommet hole A, leaving this end temporarily disconnected.
- Place a tag on the free end of the blue lead (use masking tape, or scotch tape and a small piece of paper), designating this lead as "#1". Other blue leads will subsequently be passed through to the topside of the chassis and similarly tagged to provide a means of identification.
174. (✓) Cut a 14- $\frac{1}{4}$ " length of WHITE lead. Connect it from TP-5 lug 1 (NS) to TP-8 lug 1 (NS). Dress the lead as shown.
175. (✓) Cut a 2- $\frac{1}{4}$ " length of WHITE lead. Connect one end to V3 lug 5 (S-1). Pass the free end of the lead through the hole in the bracket and connect to TP-5 lug 5 (NS). Center the lead in the bracket hole.
176. (✓) Cut each lead of a 100 μf 10% (N750) ceramic disc capacitor C12 to 1". Slip a $\frac{5}{8}$ " length of yellow sleeving over each lead and connect it from TP-5 lug 5 (S-3) to C8 lug 1 (S-1).
177. () Cut each lead of a 620 ohm 1/2 watt resistor (blue, red, brown, gold) R10 to $\frac{1}{2}$ ". Connect it between TP-5 lug 1 (S-3) and TP-5 lug 2 (S-4).
178. (✓) Cut each lead of a 0.005 μf 20% ceramic disc capacitor C6 to $\frac{1}{2}$ ". Connect it between TP-4 lug 2 (S-1) and TP-4 lug 3 (NS).
179. (✓) Cut each lead of a 33K ohm 1/2 watt resistor (orange, orange, orange, silver) R4 to $\frac{5}{8}$ ". Connect it between TP-4 lug 3 (NS) and TP-4 lug 1 (S-3).
180. (✓) Select L2, a 1 mh RF choke (23-37). Cut one lead to $\frac{1}{2}$ ", and the other to 1". Slip a $\frac{5}{8}$ " length of yellow sleeving over the $\frac{1}{2}$ " lead and connect it to TP-4 lug 3 (S-3). Connect the other end to V2 lug 2 (S-1).

181. (✓) Cut a 17-3/4" length of BLUE lead. Connect one end to V3 lug 4 (S-3). Route the lead under the control shafts as shown, and pass the free end through grommet hole A. Leave this end temporarily disconnected and tag it as #2.
182. (✓) Cut a 8-1/2" length of RED lead. Connect it from C18 (S-1) to TP-13 lug 2 (NS). Trim off surplus lead at C18.
183. (✓) Cut a 8-1/4" length of BLUE lead. Connect one end to TP-8 lug 1 (S-3). Pass the free end through grommet hole A. Leave this end temporarily disconnected, and tag it as #3.

REFER TO PICTORIAL 8

184. () Select the CRYSTAL switch SW-1 (14-47) and the shield bracket (10-150). Mount the bracket on the underside of the chassis as shown, using 6-32 hardware (2).

CAUTION: Make sure that none of the nearby connecting leads are pinched beneath the bracket.

Install the CRYSTAL switch on the bracket, using a 3/8" lockwasher and 3/8" hex nut to secure the switch. Make sure the locating lug on the face of the switch enters the small hole provided for it in the bracket.

Rotate the shaft of the crystal switch to its fully counter-clockwise position (when viewed from the shaft end). Temporarily, place the main chassis to one side.

LOW PASS FILTER ASSEMBLY

REFER TO FIGURE 7

185. (✓) Select the low-pass filter housing (10-145).
186. (✓) Mount the coaxial connector (20-282) from the inside of the chassis as shown, using 4-40 hardware (4).
187. (✓) Mount a 2-lug terminal post (20-317) as shown, using 4-40 hardware (1).
188. (✓) Mount a 2-lug terminal post (20-43) as shown, using 4-40 hardware (1).
189. (✓) Mount the ceramic stand-off terminal (20-308) as shown, using a #6 lockwasher and 6-32 hex nut.

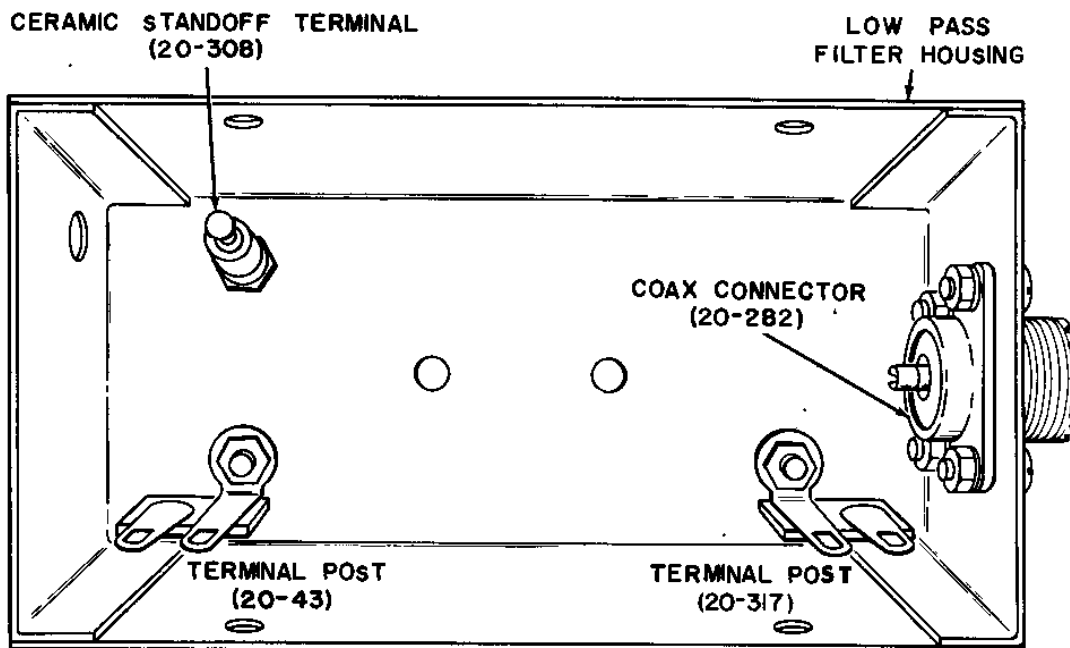

FIGURE 7

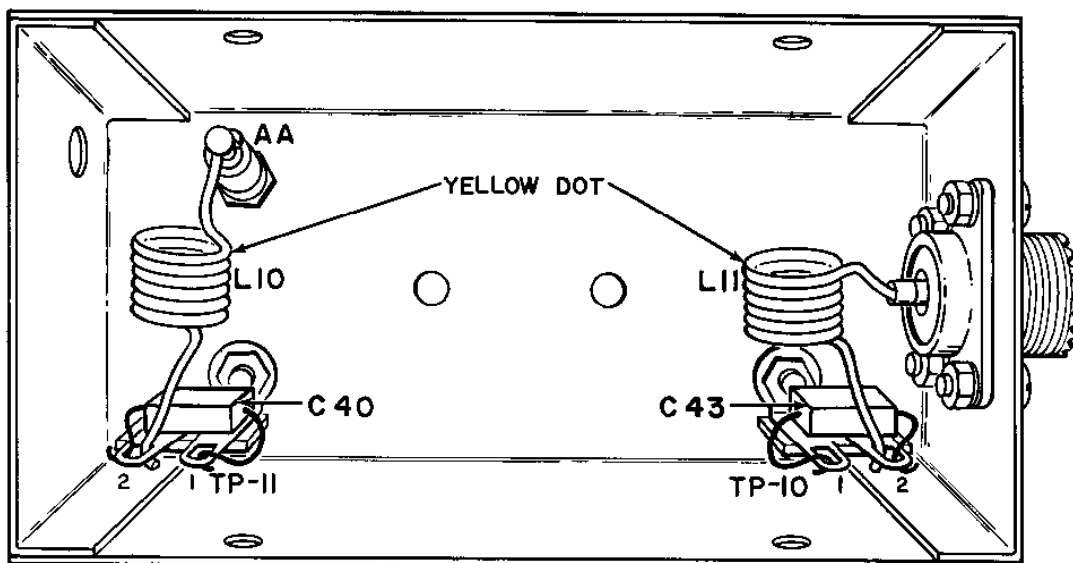

FIGURE B

REFER TO FIGURE 8

190. (✓) Connect a 47 μf 10% molded mica capacitor C43 between TP-10 lug 1 (S-1) and lug 2 (NS). Keep the capacitor leads short.
191. (✓) Connect a 47 μf 10% molded mica capacitor C40 between TP-11 lug 1 (S-1) and lug 2 (NS).
192. (✓) Select a 0.32 μh low-pass filter coil L11 (yellow dot) in bag marked with part #23-40. Pass one end of the coil through TP-10 lug 2 (S-2). Pass the other end into the center terminal of the coaxial connector (NS). Trim and bend coil leads as necessary, taking care not to spread the coil turns. Be sure to position the coil as shown, leaving space for coil L9 which will be installed later (see Fig. 9).
193. (✓) Select the other 0.32 μh low-pass filter coil L10 (yellow dot) in bag marked with part #23-40. Pass one end through TP-11 lug 2 (S-2). Bend the other end around stand-off terminal AA as shown, but do not solder.

REFER TO FIGURE 9

194. (✓) Select the U-shaped center shield (10-146), two insulated stand-off terminals (20-308), one #6 solder lug (20-24), two #6 lockwashers, and two 6-32 hex nuts. Install the center shield with the two stand-off terminals, securing them from the underside with the lockwashers and hex nuts. Be sure to mount the #6 solder lug under stand-off BB.
195. (✓) Connect a 180 μf 10% molded mica capacitor C42 between stand-off CC (NS) and the #6 solder lug (NS). Keep leads short.
196. (✓) Connect a 180 μf 10% molded mica capacitor C41 between stand-off BB (NS) and the #6 solder lug (S-2). Keep leads short.
197. (✓) Select L9, a 0.44 μh low-pass filter coil (green dot) in bag marked with part #23-41. Slip a 3/8" length of black vinyl sleeving over one lead and, passing it through the hole in the shield bracket, carefully bend the lead around stand-off CC (NS). Connect the other lead to the center terminal of the coax connector and solder (S-2).
198. (✓) Select L7, a 0.44 μh filter coil (green dot) in bag marked with part #23-41. Slip a 3/8" length of black vinyl sleeving over one lead and, passing it through the hole in the shield bracket, carefully bend around stand-off BB (NS). Bend the other lead carefully around stand-off AA (S-2).
199. (✓) Select L8, a 0.5 μh filter coil (blue dot) in bag marked with part #23-42. Connect the coil between stand-off BB and CC. Solder terminals BB (S-3) and CC (S-3). Use sufficient solder to cover all connections.

200. (✓) Mount four spade lugs (22-151) as shown, using one 6-32 screw, one #6 lockwasher and one 6-32 hex nut to mount each lug.
201. (✓) Cut a 3-3/4" length of #20 BARE WIRE. Form a hook at one end and pass through the hole in one end of the filter housing. Connect to the lead of either L7 or L10 and solder. Leave the other end of the bare wire temporarily disconnected.

Temporarily, Refer to Pictorial 9

202. (✓) Mount the completed low-pass filter housing onto the chassis as shown. To mount it, pass the free end of the bare wire (from the housing) through the hole in the final amplifier shield, and then guide the housing forward and then downward, allowing the studs to enter into the corresponding holes in the chassis. Secure the housing from the underside of the chassis by means of four #6 lockwashers and four 6-32 hex nuts.
203. (✓) Cut a 3-1/4" length of yellow sleeving. Slip it over the bare wire, making sure the sleeving is pushed as far as it will go into the filter housing. Leave the free end of the wire temporarily disconnected -- the remainder of the wiring shown in Pictorial 9 will be completed at a later stage.

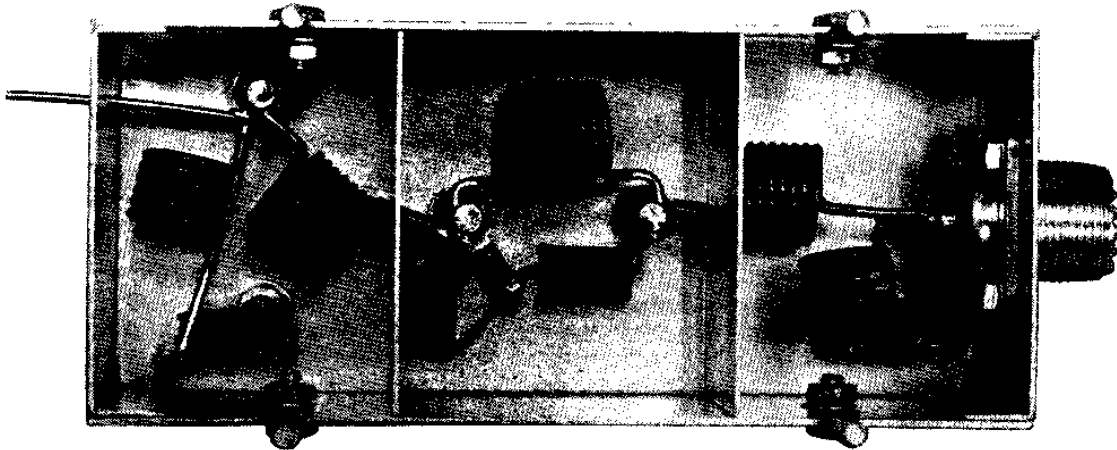
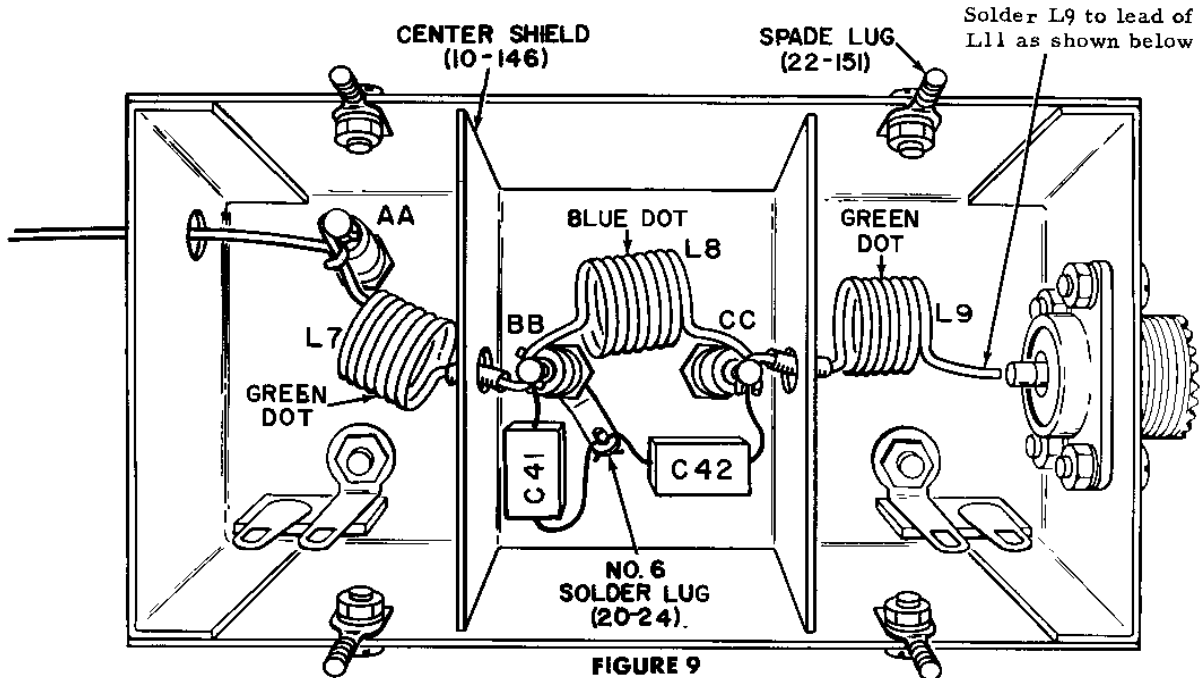

COMPLETED WIRING

REFER TO FIGURE 10

204. *Z* Select the crystal socket bracket (10-149), five crystal sockets (19-45), five 2-56 x 1/2" screws, five #2 lockwashers, and five 2-56 hex nuts.

Install the five sockets on the bracket as shown, using 2-56 hardware to secure each socket.

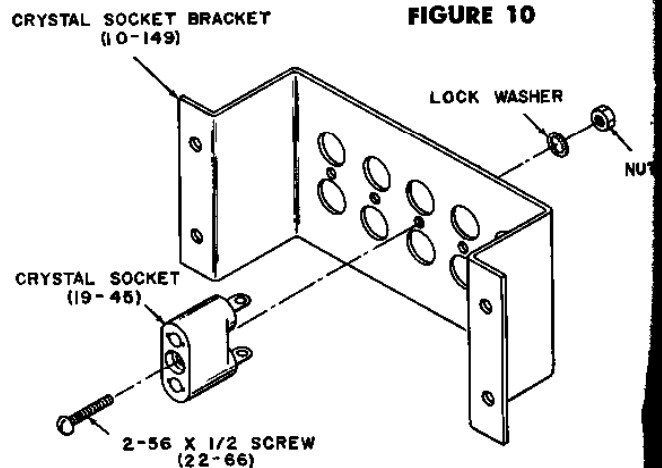









UNDERCHASSIS WIRING - III

REFER TO PICTORIAL 8

NOTE: For convenience, the next two steps should be carried out before installing the crystal bracket onto the chassis.

205. *Z* Twist each of the lower lugs (B) of the sockets approximately 45 degrees. Cut a 2-1/2" length of bare wire and pass it through each of these lugs. Crimp the wire at the two extreme lugs.
206. *Z* Cut each lead of a 0.001 μ f 10% ceramic disc capacitor C1 to 3/4". Slip a 1/2" length of yellow sleeving over one lead only, and connect this end to socket X1 lug B (S-2). Solder lug B of each remaining socket.
207. *Z* Install the socket bracket onto the rear apron of the chassis as shown, using four #8 x 3/8" sheet metal screws (hex head) to secure the bracket. Do not connect the free end of C1 yet -- it will be connected, with sleeving, at a later time.
208. *Z* Cut an 11" length of RED/WHITE lead. Connect it from SW-1 lug 9 (S-1) to J-1 lug 3 (S-1).
209. *Z* Cut a 7-1/2" length of RED/WHITE lead. Connect it from SW-1 lug 10 (S-1) to TP-3 lug 3 (NS).
210. *Z* Slip a 1/2" length of sleeving over the free end of C1 and connect to V1 lug 3 (S-1).
211. *Z* Cut a 6" length of YELLOW lead. Connect it from SW-1 lug 6 (S-1) to J-2 lug 1 (S-1).
212. *Z* Cut a 2-3/4" length of YELLOW lead. Connect it from SW-1 lug 12 (S-1) to V1 lug 2 (S-1).
213. *Z* Cut a 1-1/2" length of bare wire. Connect it from X5 lug A (S-1) to SW-1 lug 5 (S-1).
214. *Z* Cut a 1-1/2" length of bare wire. Connect it from X4 lug A (S-1) to SW-1 lug 4 (S-1).
215. *Z* Cut a 1-5/8" length of bare wire. Connect it from X3 lug A (S-1) to SW-1 lug 3 (S-1).
216. *Z* Cut a 1-3/4" length of bare wire. Connect it from X2 lug A (S-1) to SW-1 lug 2 (S-1).
217. *Z* Cut a 1-3/4" length of bare wire. Connect it from X1 lug A (S-1) to SW-1 lug 1 (S-1).
218. *Z* Select a 50 μ f 10% ceramic disc capacitor C4. Cut one lead to 3/4". Slip a 1-1/4" of sleeving over the other lead. Pass the end with sleeving through the hole in the shield bracket and connect it to V2 lug 9 (S-1). Connect the other end of the capacitor to L1 lug 1 (S-2). Center the covered wire in the hole.
219. *Z* Cut each lead of a 100 μ f 10% ceramic disc capacitor C3 to 3/8". Connect from V1 lug-8 (NS) to the center post of V1. Solder the center post. Use sufficient heat and solder to ensure a good connection between all lugs and wire at the center post.

220.  Cut each lead of a 15K ohm 2 watt resistor (brown, green, orange, silver) R2 to 3/4". Connect one end to TP-3 lug 3 (S-4). Pass the other end through (do not crimp to) V1 lug 8 and solder (S-2).
221.  Cut each lead of a 100K ohm 1/2 watt resistor (brown, black, yellow, silver) R1 to 1". Connect it from TP-3 lug 4 (NS) to V1 lug 9 (S-1).
222.  Connect a short length of bare wire between J-1 lug 1 (S-1) and J-1 lug G3 (S-1).
223.  Cut a 2-1/2" length of WHITE lead. Connect it from J-1 lug 8 (S-1) to TP-3 lug 4 (S-5).
224.  Select the four diodes, D-2, D-3, D-4, D-5, (marked 1723). Cut the leads of each diode to 1" in length.
225.  Connect D5 from TP-7 lug 1 (NS) to TP-8 lug 4 (NS). Orient as shown.
226.  Connect D4 from TP-7 lug 1 (S-2) to TP-8 lug 3 (NS). Orient as shown.
227.  Connect D3 from TP-7 lug 2 (NS) to TP-8 lug 3 (S-3). Orient as shown.

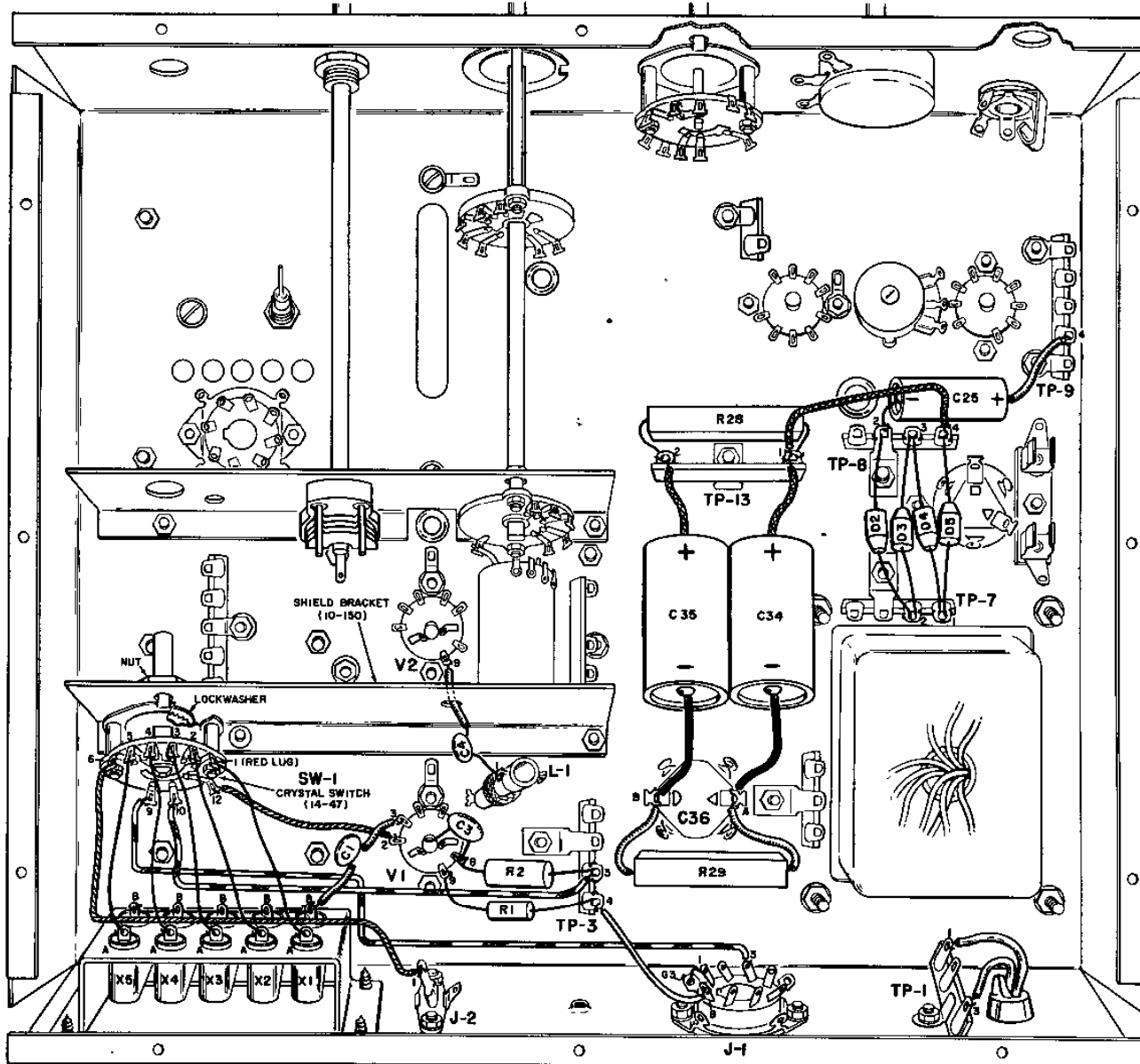

PICTORIAL 8

228. (Z) Connect D2 from TP-7 lug 2 (S-2) to TP-8 lug 2 (NS). Orient as shown.
229. (Z) Select a 10 μ f 350 volt electrolytic capacitor (12-196) C25. Cut the positive (+) lead to 1-3/8". Cut the negative (-) lead to 1". Slip a 1-1/4" length of sleeving over the positive lead and connect it to TP-9 lug 4 (S-4). Connect the negative lead to TP-8 lug 2 (S-3).
230. (Z) Select a 150 ohm 8 watt wirewound resistor (13-272) R29. Slip 1-1/4" of yellow sleeving over each lead (leave leads full length). Connect the resistor from C36 lug A (NS) to C36 lug B (NS). Position the resistor as shown, making sure it does not rest against any of the interconnecting leads.
231. (Z) Cut each lead of a 150 ohm 8 watt wirewound resistor (13-272) R28 to 1". Connect from TP-13 lug 1 (NS) to TP-13 lug 2 (NS). Position the resistor as shown, keeping it away from any neighboring leads.
232. (Z) Cut a 3-1/2" length of RED/WHITE lead. Connect it from TP-13 lug 1 (NS) to TP-8 lug 4 (S-2). Bend and position the lead as shown so that it is kept well away from nearby leads.
233. (Z) Select a 30 μ f 450 volt electrolytic capacitor (12-194) C34. Cut the positive (red) lead to 1-5/8", and the negative (black) lead to 1-3/4". Connect the positive lead to TP-13 lug 1 (S-3), and the negative lead to C36 lug A (S-3). Position as shown.
234. (Z) Select another 30 μ f 450 volt electrolytic capacitor (12-194) C35. Cut the negative (black) lead to 1-3/8", and the positive (red) lead to 1-5/8". Connect the positive lead to TP-13 lug 2 (S-5), and the negative lead to C36 lug B (S-4). Dress as shown.
- NOTE: Make sure all connections at TP-13 lug 2 and C36 lug B are properly soldered.

REFER TO FIGURE 11

235. (Z) Select the AC line cord (20-318) and the strain relief (20-215). Cut the stripped (bare wire) ends to 3/8" in length. Insert the line cord into the strain relief, allowing the stripped end of the cord to project 2-3/4" beyond the relief, as shown in (A). Clamp together as shown in (B), and then feed the stripped ends through the hole in the rear apron of the chassis (near TP-1). Press the strain relief into this hole until it snaps into place, as shown in (C).

Referring to Pictorial 8, connect one lead to TP-1 lug 1 (S-4), and the other lead to TP-1 lug 3 (S-3). Be sure not to burn any neighboring leads when soldering the connections at TP-1 lug 1. Also, make sure the use of excess solder does not cause a short-circuit between this lug and the chassis.

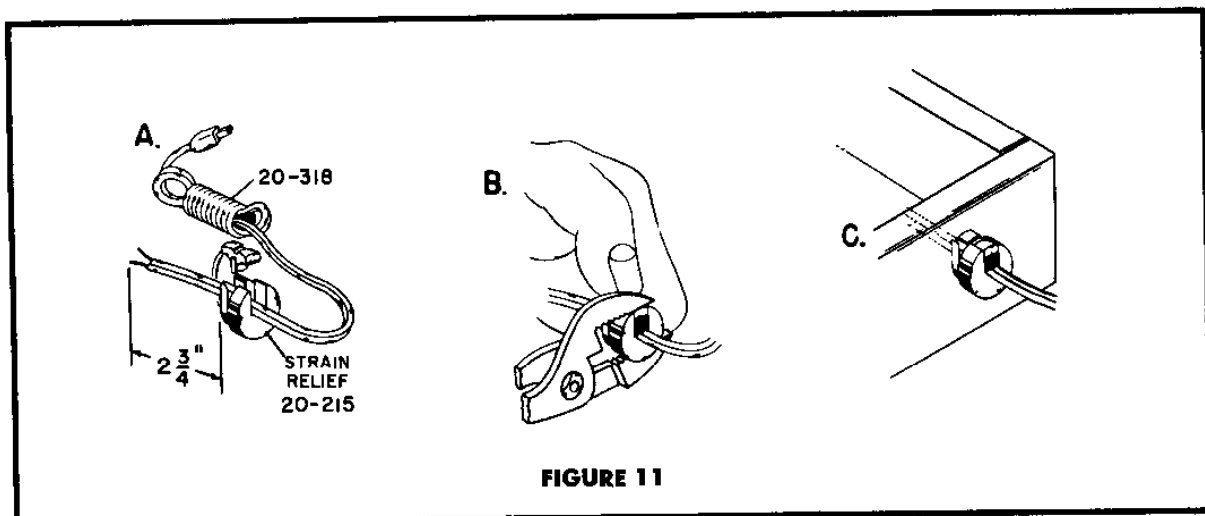
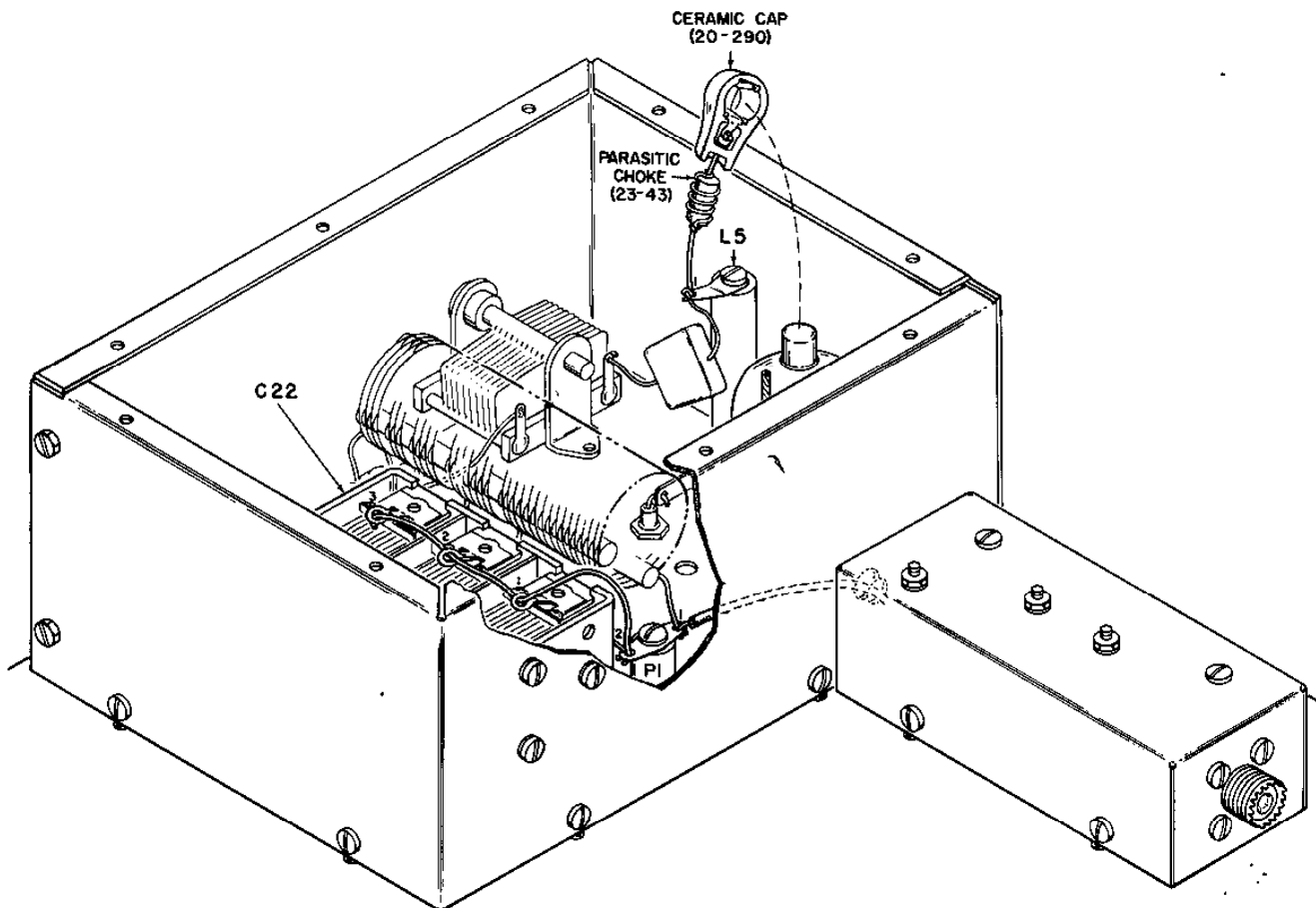

FIGURE 11



PICTORIAL 9

TOPCHASSIS WIRING—1

REFER TO PICTORIAL 9

236. (✓) Connect the free end of the covered lead from the filter housing to P1 lug 1 (S-2). To simplify this operation, form a sharp bend at the end of the wire and simply pass it through the hole in the lug.

CAUTION: Keep this lead away from the neutralizing stub. Also, make sure it is centered in the hole in the shield.

237. (✓) Raise (slightly) lugs 1, 2 and 3 of variable capacitor C22. Next, twist each lug approximately 45 degrees. Locate the heavy bare wire coming from P1 lug 2. Pass the free end of this wire through lugs 1, 2 and 3 of C22. Remove surplus wire at lug 3 and then solder all lugs.

238. () Select the parasitic choke (23-43) and ceramic cap (20-290). Cut one lead of the choke to 5/8" and pass this end into the lug within the ceramic cap as shown. Solder this connection. Cut the other lead of the choke to 1-1/8" in length and connect to L5 lug 1 (S-2). Insert the final amplifier tube V3, 6146, into the socket. Carefully, press the ceramic cap onto the top cap of the tube.

FRONT PANEL ASSEMBLY

REFER TO PICTORIAL 10

239. (✓) Select the escutcheon (10-144). Peel off the protective plastic covering. Install the DPDT meter switch (14-17C) on the escutcheon as shown. Use 4-40 hardware (2) but on one side, add a solder lug (22-106). Tighten screws firmly, but make sure you do not scratch the escutcheon.
240. (✓) Temporarily, remove the bushing, four hex nuts and one washer from the front apron of the chassis. Place the washer and hex nut used to secure the key jack to one side. The hex nut is non-standard, and must not be mixed with the others.
241. (✓) Attach the escutcheon to the front of the chassis, securing it firmly by means of the hardware removed in the previous step. To re-assemble the panel bushing, secure it from inside the chassis with its hex nut. Use the washer and special hex nut to secure the key jack (make sure the jack does not twist as you tighten the hex nut).

CAUTION: Use care when tightening all hex nuts so as not to scratch the escutcheon.

242. () Select the mike connector (20-228). Disassemble the connector and discard the two fiber washers and ground lug. Install the connector as shown, using a 3/8" lockwasher and the hex nut just removed.
243. (✓) Stand the chassis on edge (power transformer closest to the work surface) and, referring to Detail A of Pictorial 10, locate the Crystal switch. Make sure the switch is in the fully counter-clockwise position (when viewed from the shaft end).

Slip the end of the long 1/4" diameter shaft (22-150) into hole (A) in the escutcheon. Remove the hex nut from the panel bushing (22-90) and slip the nut over the shaft as shown. Pass the end of the shaft through the hole in the shield bracket and attach to the switch shaft, using the shaft coupler (22-147) as shown.

WARNING: Before tightening the screws, make sure the coupler is oriented as shown, with screws perpendicular to the chassis. Tighten screws securely.

Finally, install the panel bushing at hole (A), securing it with the loose hex nut.

FIGURE 12

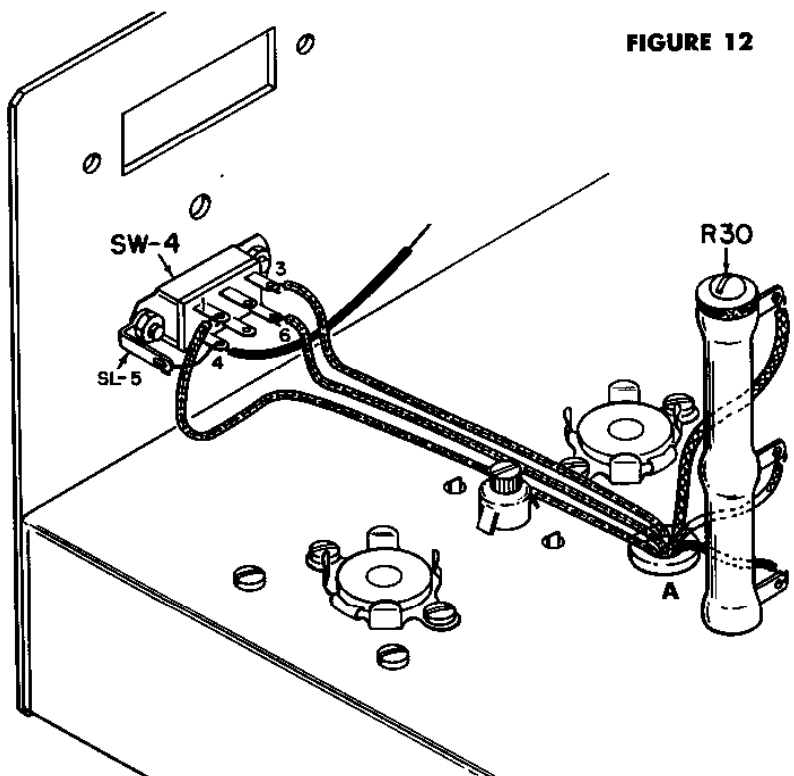

REFER TO FIGURE 12

244. (✓) Connect the free end of the black lead from grommet hole A to R30 lug 3 (S-1).
245. (✓) Similarly, connect the free end of the red/white lead to R30 lug 2 (S-1).
246. (✓) Connect the free end of the red lead to R30 lug 1 (S-1).
247. (✓) Connect the free end of the blue lead tagged as #1 (the other end is connected to TP-5 lug 2) to SW-4 lug 6 (S-1).

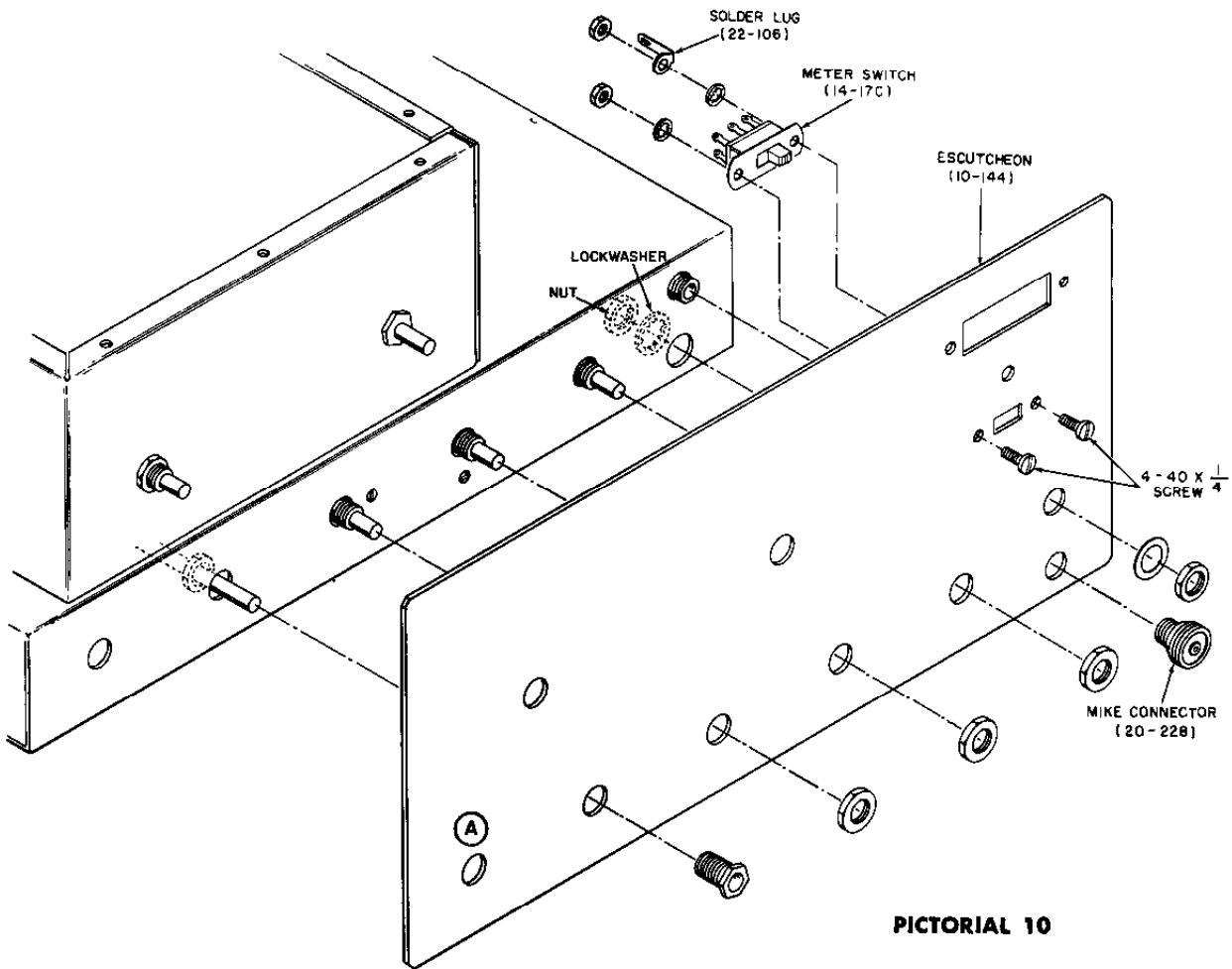
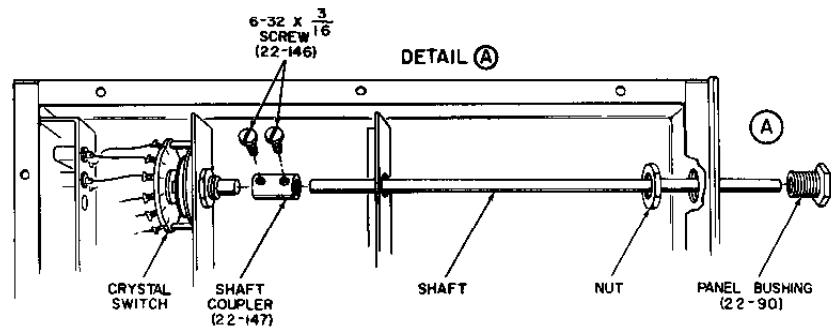



PICTORIAL 10

248.  Connect the free end of the blue lead tagged as #3 (the other end is connected to TP-8 lug 1) to SW-4 lug 3 (S-1).
249.  Connect the free end of the blue lead tagged as #2 (the other end is connected to V3 lug 4) to SW-4 lug 1 (S-1).
250.  Cut a 2-3/4" length of BLACK lead. At one end, strip off the normal 1/4" of insulation. At the other, strip off 3/4" of insulation. Pass the bare wire at this end through lug 4 of SW-4 and connect to SL-5. Solder at SL-5 and lug 4 of SW-4. Leave the other end of the lead temporarily disconnected.

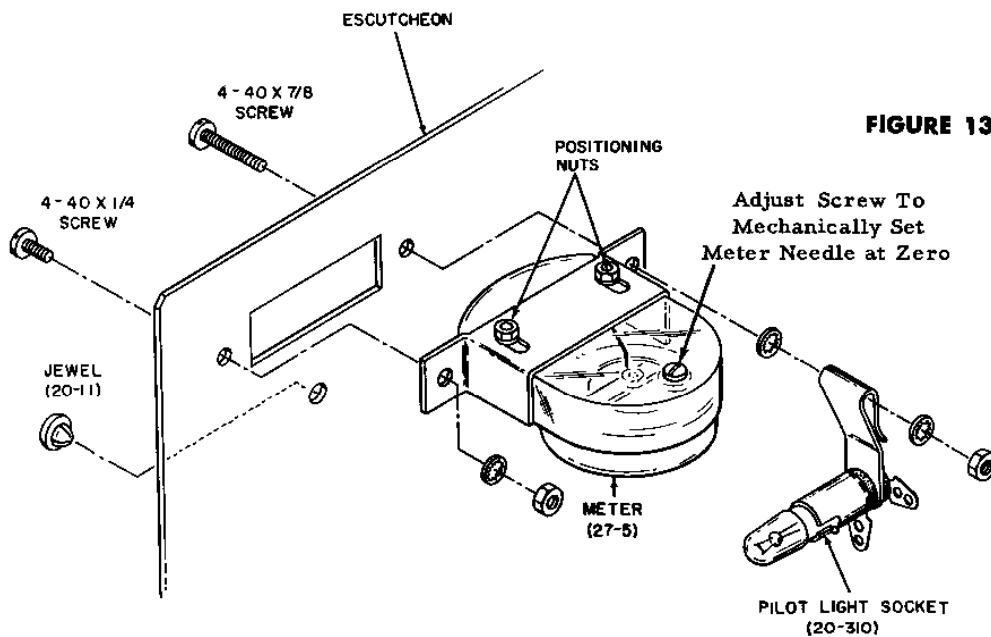

FIGURE 13

REFER TO FIGURE 13

251. Select the 0-1 ma meter (27-5). Loosen (slightly) the meter bracket positioning nuts. Push meter body forward as far as it will go in the bracket. Tighten nuts carefully. Insert the lamp in the pilot light socket (20-310).

Install the meter assembly in the escutcheon, using the hardware shown. On the 4-40 x 7/8" screw mount the pilot light assembly between the two lockwashers and attach. Position the pilot light so that it lies over the hole for the jewel.

252. Insert the pilot light jewel (20-11) into the hole in the escutcheon.

REFER TO FIGURE 14

253. Select a 0.005 μ f 20% ceramic disc capacitor C17. Pass one lead of C17 through lug 2 of the meter. CAUTION: Use care when passing wire through the meter lugs. They are fairly soft and will not stand too much abuse. Now, slip a 3/4" length of yellow sleeving over the bare wire and connect it to SW-4 lug 5 (S-1).

Pass the other lead of C17 through lug 1 of the meter, and after cutting off surplus wire, crimp it to this lug (NS).

254. Select a 2.2K ohm 1/2 watt resistor (red, red, red, silver) R12. Cut one lead to 1/2" and the other to 3/4". Connect the 1/2" end to SW-4 lug 2 (S-1). Carefully, wrap the end of the 1" lead around lug 1 of the meter and solder (S-2).
255. Connect the free end of the black lead from SW-4 lug 4 to PL-1 lug 2 (S-1).
256. Connect the free end of the yellow lead coming from grommet hole A to PL-1 lug 1 (S-1).

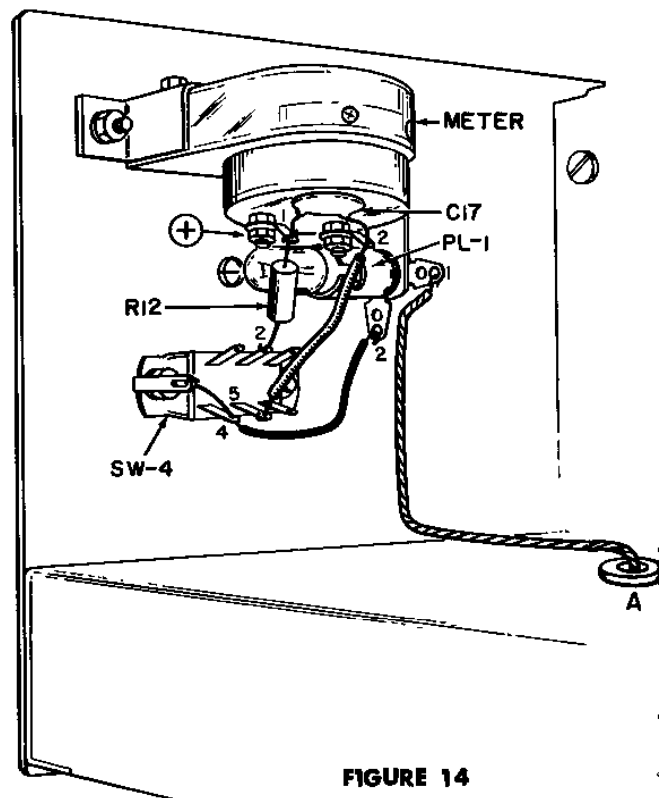

FIGURE 14

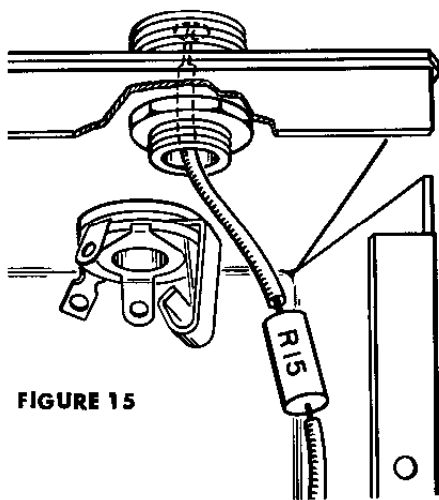

FIGURE 15

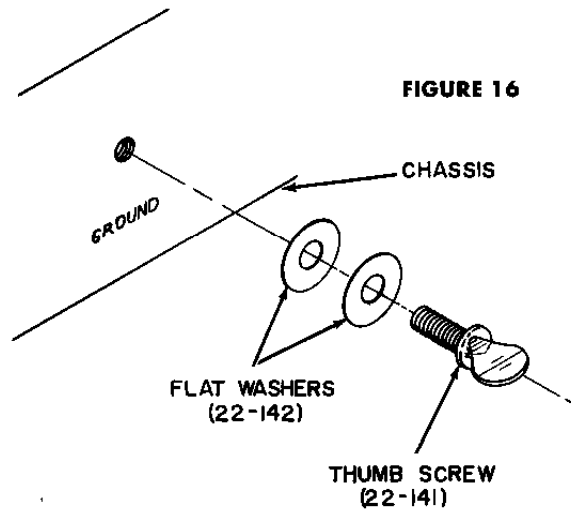

FIGURE 16

REFER TO FIGURE 15

257. (✓) Slip 1-1/4" of yellow sleeving over the free end of R15 on the underside of the chassis. Pass the bare wire end through the center of the connector. Solder this connection at the front of the connector. Remove any surplus wire, if necessary. DO NOT USE AN EXCESSIVE AMOUNT OF SOLDER FOR THIS CONNECTION.

258. (✓) Install the 3 AMP, 3AG fuse in the fuseholder.

REFER TO FIGURE 16

259. (✓) Install the thumbscrew (with two flat washers) in the GROUND hole in the rear apron of the chassis.

INSTALLATION OF KNOBS AND TUBES

260. (✓) Turn the shafts of the following controls to their fully counter-clockwise positions; CRYSTAL switch, BAND switch, MODE switch and DRIVE LEVEL control,

Install a small skirted knob (18-70) on each of these four shafts with the indicating arrow at the first designated position. Secure each knob with the set screw.

261. (✓) Rotate the shaft of the DRIVE TUNE capacitor until the plates are fully meshed. Install a small knob on the shaft with the indicating arrow at position #1. Secure with the set screw in the knob.

262. (✓) Rotate the shaft of the FINAL TUNING capacitor until the plates are fully meshed. Install a large skirted knob (18-69) on the shaft with the indicating arrow at the 9 o'clock position. Secure with the set screw in the knob.

263. (✓) Rotate the shaft of the FINAL LOADING capacitor to its fully counter-clockwise position. Install a large skirted knob on the shaft with the indicating arrow at the "O" designation. Secure with the set screw in the knob.

264. (✓) Insert tubes V1 and V2 (6CL6) into their sockets. See Pictorial 11 for location of all tubes. Install a large shield (20-304) over V1 and V2.

265. (✓) Insert tube V4 (12AX7/ECC83) into its socket. Install a smaller shield (20-173) over this tube.

266. (✓) Insert tube V5 (6DE7) into its socket. Install a large shield (20-304) over this tube.

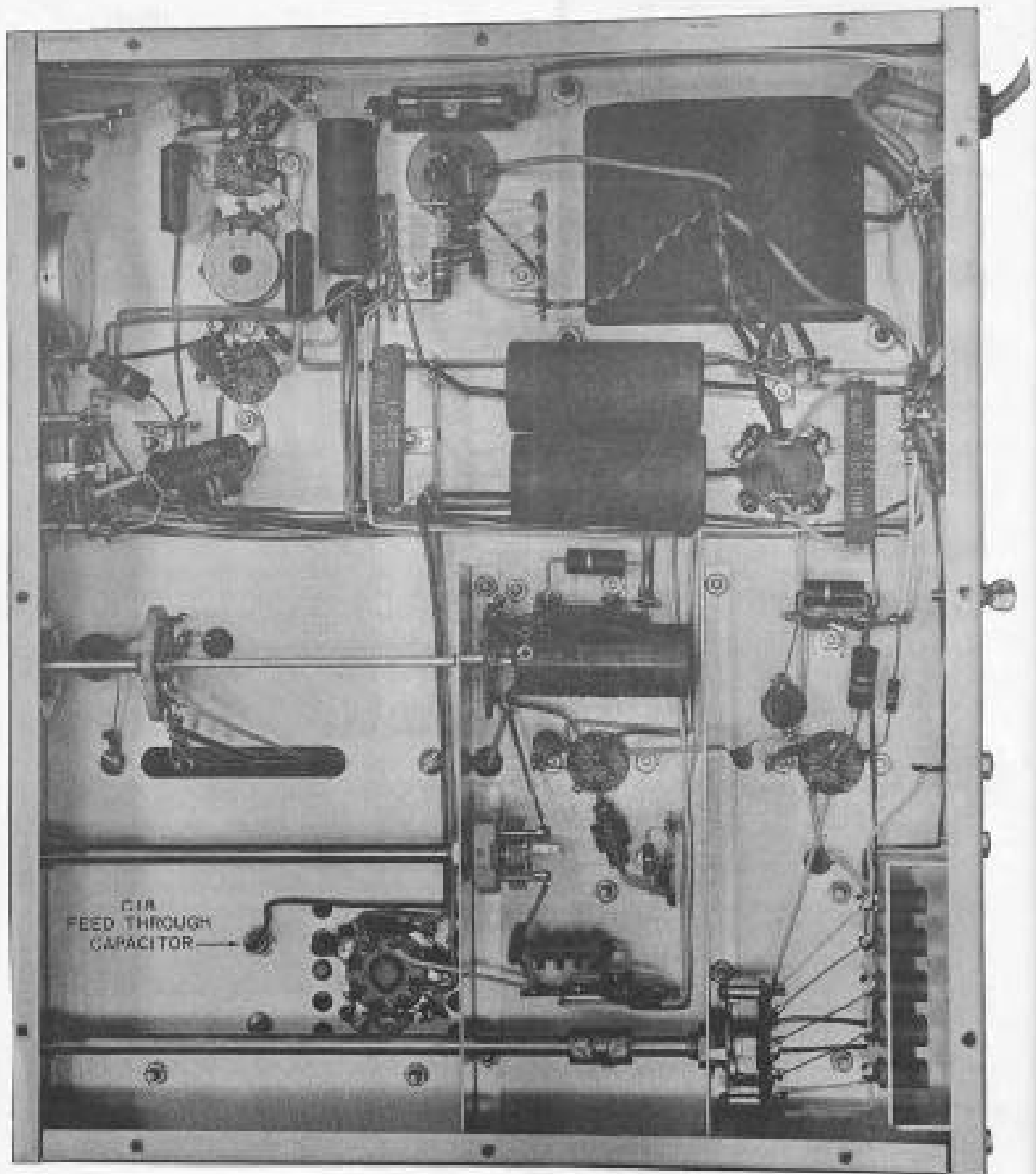

PICTORIAL 12
COMPLETED WIRING — UNDERCHASSIS VIEW

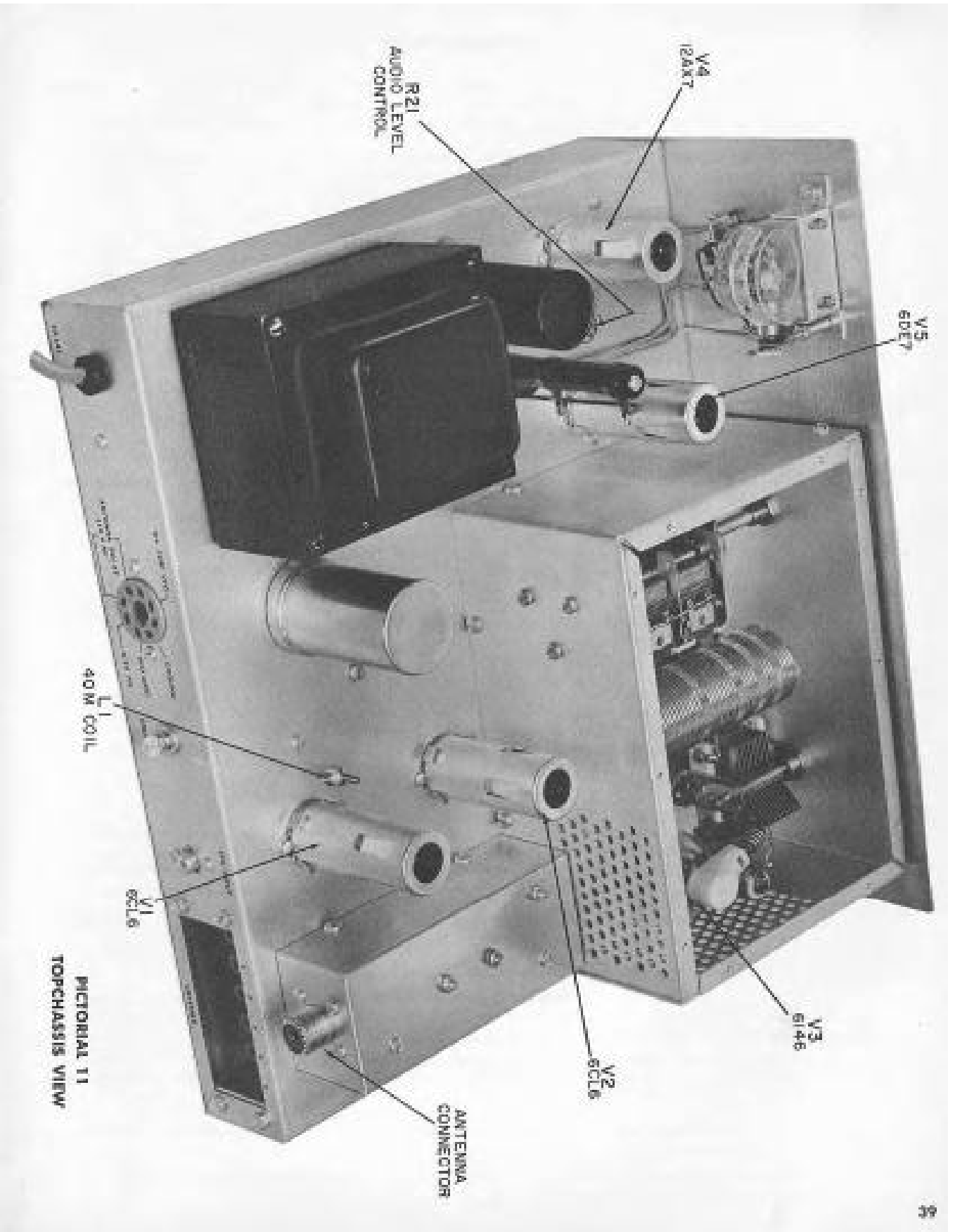

R21
AUDIO LEVEL
CONTROL

V4
12AX7

V5
6DE7

40W COIL

V1
6CL6

PICTORIAL 11
TOP CHASSIS VIEW

ANTENNA
CONNECTOR

V2
6CL6

V3
6146

PRELIMINARY TESTS

The wiring of the transmitter has now been completed. Before proceeding with the initial adjustments, make a careful check of the wiring -- all connections should be properly soldered. Make sure there are no unintentional short circuits. Remove any wire clippings and solder splashes from the chassis.

As a further precaution, a preliminary check of the power supply section should be made. An ohmmeter check across the filter capacitors will show whether or not there is a shorted B+ line and thus may guard against possible damage to the rectifiers. *Measure from lug 2 of TP-13 (see Pictorial 8) to chassis. Use one of the higher ohmmeter ranges and observe the meter pointer as the capacitor charges. Some ranges of the ohmmeter may charge the capacitor more quickly than others. When the meter pointer finally comes to rest the reading should be 25K ohms or greater to indicate the absence of shorts or excessive leakage in the capacitors. If a short is indicated, it should be located and removed before proceeding any further (see section headed "IN THE EVENT OF DIFFICULTY"). *Set Mode switch in AM position. After making measurement, return switch to off position.

INITIAL ADJUSTMENTS

CAUTION: A DUMMY LOAD AND CRYSTAL (PREFERABLY 80 METER) MUST BE USED FOR THE INITIAL ADJUSTMENTS.

1. (✓) Construct a dummy load as shown in Figure 17. Use a 75 watt bulb, #16 bare wire and a coaxial connector (PL-259 or equivalent).
2. (✓) Attach the dummy load to the antenna connector on the low-pass filter.
3. (✓) Insert a crystal (preferably 80 meter) in crystal socket #1.
4. (✓) Set FINAL TUNING control and BAND switch to the panel marking for the band being used.
5. (✓) Place all remaining controls in their maximum counter-clockwise positions (place DRIVE TUNE at 1).

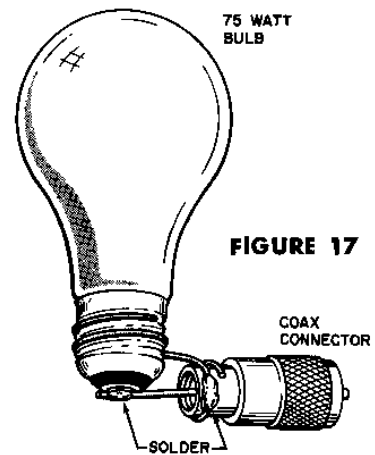

FIGURE 17

WARNING

WHEN POWER IS APPLIED, LETHAL VOLTAGES ARE PRESENT BOTH ABOVE AND BELOW THE TRANSMITTER CHASSIS. KEEP HANDS AWAY FROM HIGH VOLTAGE POINTS AND USE ONLY WELL INSULATED TOOLS FOR ANY ADJUSTMENTS WITHIN THE CHASSIS.

6. (✓) Plug the line cord into an outlet furnishing 105-125 volts, 50/60 cycles AC.
7. (✓) Set the MODE switch to the STBY (standby) position. The pilot light and all tube filaments should light. If they do not, or if you notice any overheating, arcing or smoke, immediately unplug the transmitter from the AC outlet and refer to the section headed "In The Event of Difficulty". Leave Mode switch at STBY about 60 seconds before changing function.
8. (✓) If everything appears normal, check that the CRYSTAL switch is in the X1 position and that the METER switch is in the GRID position.
9. () Set the MODE switch to the TUNE position.

CAUTION: This transmitter produces generous amounts of grid drive on all bands. To prevent tube damage, however, do not allow grid drive to exceed 2.5 ma. When excessive, grid drive should be reduced by means of the DRIVE LEVEL control.

If you are unable to obtain a grid drive reading in the next step, do not continue -- the final amplifier may be damaged. In such a case, switch the transmitter off and refer to the section headed "In The Event of Difficulty".

10. (✓) Advance the DRIVE LEVEL control to 1. Adjust the DRIVE TUNE control for a maximum reading on the meter.

When you have obtained a peak reading with the DRIVE TUNE control, adjust the DRIVE LEVEL control for a reading of 2.5 ma.

11. Return the MODE switch to the "STBY" position.
WARNING: If you are unable to obtain the indicated results in any of the following steps, switch the transmitter off and refer to the section headed "In The Event of Difficulty".
12. Set the METER switch to the "Plate" position.
13. Set the MODE switch to the "AM" position and immediately adjust the FINAL TUNING control for a minimum (dip) reading on the meter.
14. Set the MODE switch to "CW".
15. Advance the FINAL LOADING control approximately 1/4 turn and then readjust FINAL TUNING for a dip. The meter reading will have increased and there may be a glow from the dummy load.
16. Advance the FINAL LOADING control in 1/4 turn steps, readjusting the FINAL TUNING for a dip in meter reading after each 1/4 turn. Repeat this procedure until the meter reading reaches 150 ma at the dip.
17. Set the METER switch to the "grid" position and adjust DRIVE LEVEL for a reading of 2.5 ma. Return the METER switch to the "Plate" position and the MODE switch to the "STBY" position.
WARNING: In the next step, be sure to use an insulated screwdriver for adjustment of R21. Use extreme caution -- there are lethal voltages present on the lugs of the large center-tapped resistor R30.
18. Connect a crystal or other high impedance microphone to the MIKE jack. Set MODE switch to "AM".
Speak into the microphone in a normal tone. You will notice that the meter pointer will fluctuate in accordance with your voice. While speaking, adjust the audio level control R21 (see Pictorial 11) until the meter peaks at the point to which the transmitter was loaded on CW.
19. Return the MODE switch to "STBY".
20. Now, repeat steps 4 through 17 with the Band switch in the 40, 20, 15 and 10 meter positions. The use of a 40 meter crystal is recommended for these bands. The audio level control R21 will not require further adjustment. Use #1 crystal socket for the 40 meter crystal.
21. Set BAND switch to 10 meters and METER switch to "grid". Insert a 40 meter crystal in the #2 crystal socket -- use a crystal that will multiply up to the center of the 10 meter band.
22. Set CRYSTAL switch to "X2".
23. Set the MODE switch to "Tune". Adjust DRIVE TUNE for maximum, setting DRIVE LEVEL for normal 2.5 ma grid drive.
24. Now, adjust the coil slug of L1 (see Pictorial 11) for maximum reading on the meter. If grid drive exceeds 2.5 ma, reduce with DRIVE LEVEL.
25. Switch the transmitter off and remove the AC line cord from the AC outlet.

NEUTRALIZING ADJUSTMENT

The purpose of neutralization is to reduce to a minimum the RF driver voltage fed from the input of the final amplifier to its output circuit through the grid-plate capacitance of the tube, and thus ensure stable amplifier operation. In the KT-390, this is accomplished by proper adjustment of the neutralizing stub in the amplifier compartment.

If a grid dip meter or VTVM is not available, a preset adjustment may be made as follows:

Unplug the line cord from the AC outlet, and simply position the neutralizing stub about 1/4" from the final amplifier tube (and parallel to it).

If an RF indicator is available, you may use the following method for neutralization.

1. () Unplug the AC line cord. Set the transmitter on end and disconnect the heavy red lead from feed-through capacitor C18 (see Pictorial 12). This disconnects B+ voltage from the plate of the final amplifier.
2. () Reconnect the AC line cord and turn MODE switch to "STBY". Allow 60 seconds for the tubes to reach operating temperature.
3. () Insert a 40 meter crystal in the #2 socket -- as before, use a crystal that will multiply up to the center of the 10 meter band.
4. () Set the BAND switch to 10 meters, the METER switch to "grid" and CRYSTAL switch to "X2".
5. () Set the MODE switch to TUNE.
6. () Adjust DRIVE TUNE for maximum, then set DRIVE LEVEL for 2.5 ma.
7. () Loosely couple a grid dip meter to the 10 meter section of the final tank coil (the portion of the coil nearest the front panel), or connect the RF probe of a VTVM between the coaxial output connector and chassis. Use a low AC range.
8. () Set FINAL LOADING to zero and FINAL TUNING for maximum reading on the RF indicator (grid dip meter or VTVM).
WARNING: Use care when adjusting the neutralizing stub. Do not touch any bare wire that may be exposed at the tip -- there is a potential of approximately 300 volts on this wire.
9. () Adjust the position of the neutralizing stub for a minimum reading on the RF indicator (by moving the stub closer to, or further away from, the final amplifier tube). Readjust FINAL TUNING for a peak indication again, then reposition the neutralizing stub for minimum RF indication. When you have properly neutralized the final amplifier, rotation of the FINAL TUNING capacitor will cause very little variation in the RF indicator reading.
NOTE: Neutralization should be rechecked whenever the final amplifier tube is replaced.
10. () Switch the transmitter off and remove the line cord from the AC outlet.
11. () Reconnect the heavy red lead to feed-through capacitor C18.

FINAL ASSEMBLY

REFER TO PICTORIAL 13

1. () Attach the cover plate (10-152) to the top of the final amplifier compartment, using ten #4 x 1/4" sheet metal screws. Be sure to install the plate in the position shown, with the small square cut-out to the front. Do not overtighten the screws.
2. () Attach four rubber feet (20-315) to the bottom plate (10-142). Use one 8-32 x 3/8" screw, one #8 lockwasher and one 8-32 hex nut for each foot, as shown.
3. () Attach the bottom plate to the underside of the transmitter chassis. Install the plate so that the ventilation holes are closest to the rear of the chassis. Use twelve #8 x 3/8" sheet metal screws (hex head).
4. () Install the cover (10-143), using four #8 x 3/8" sheet metal screws (binding head, nickel plated).

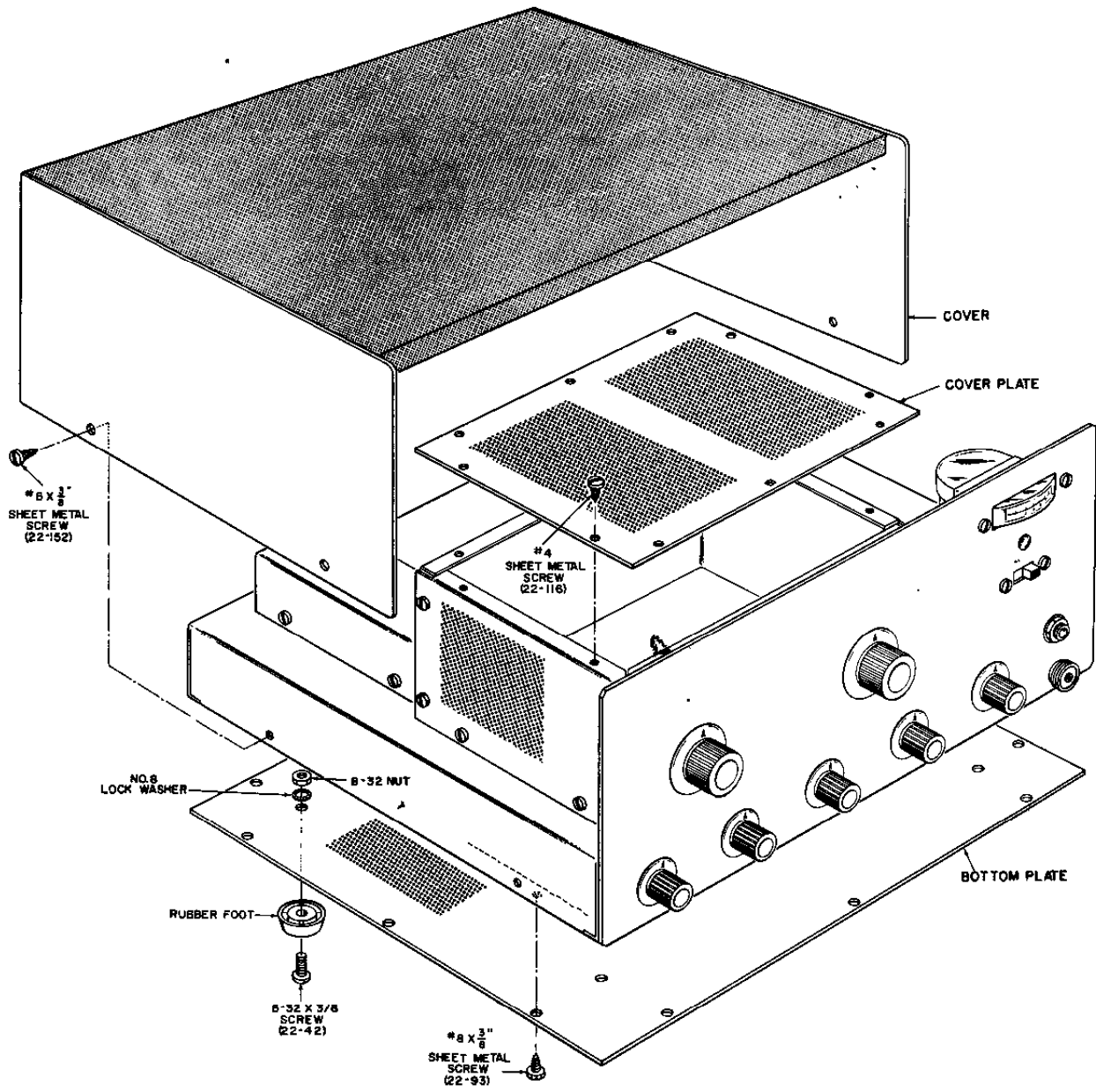

PICTORIAL 13

RESISTANCE CHART

1. Measurements taken with AC plug disconnected and Mode switch in "off" position.
2. Measurements taken from chassis to point indicated.

Tube	P I N S								
	1	2	3	4	5	6	7	8	9
V1-6CL6	0	100K	50K	0	0	35K	0	50K	100K
V2-6CL6	0	33K <i>43K</i>	0-30K Depends on Level Position	0	0	35K	0	0-30K Depends on Level Position	33K <i>43K</i>
V3-6146	10 ohms	0	Infin.	10 ohms	5K <i>1kΩ</i> <i>20K</i>	10 ohms	0	0	---
V4-12AX7	600K	0-100K Depends on Gain Position	4.7K	0	0	600K	2.2M	0	0
V5-6DE7	25K	1.5M	1.5M	0	0	1.5M	22M	0	33K

VOLTAGE CHART

1. Readings taken with line voltage maintained at 110 volts AC.
2. Measurements taken with VTVM and made from chassis to point indicated.
3. All voltages shown are DC unless otherwise indicated.
4. Variation of $\pm 15\%$ in readings possible.
5. Mode switch in AM position.

Tube	P I N S								
	1	2	3	4	5	6	7	8	9
V1-6CL6	0	-23*	210	6.3 AC	6.3 AC	270	0	210	-23*
V2-6CL6	0	-150	12 ++	6.3 AC	6.3 AC	300	0	12 ++	-150
V3-6146**	.75	0	100***	.75	-40	.75	6.3 AC	0	---
V4-12AX7	140	0	1.35	0	0	80	-.5	0	6.3 AC
V5-6DE7	620	20***	20***	0	6.3 AC	20***	-.8	0	120***

* Varies with crystal activity.

** Do not attempt 6146 Plate Cap Voltage Measurement.

*** Voltage varies with Modulation.

~~++~~ Varies with Drive Level Position.

C33a, b..... -135V (measured between lugs of capacitor casing and chassis)

C34 640V

C35 620V

C36 lug A..... 310V

C36 lug B..... 300V

NOTE: Voltage measurements were made with dummy load connected and transmitter properly tuned up on 80 meters. Some readings may differ on other bands.

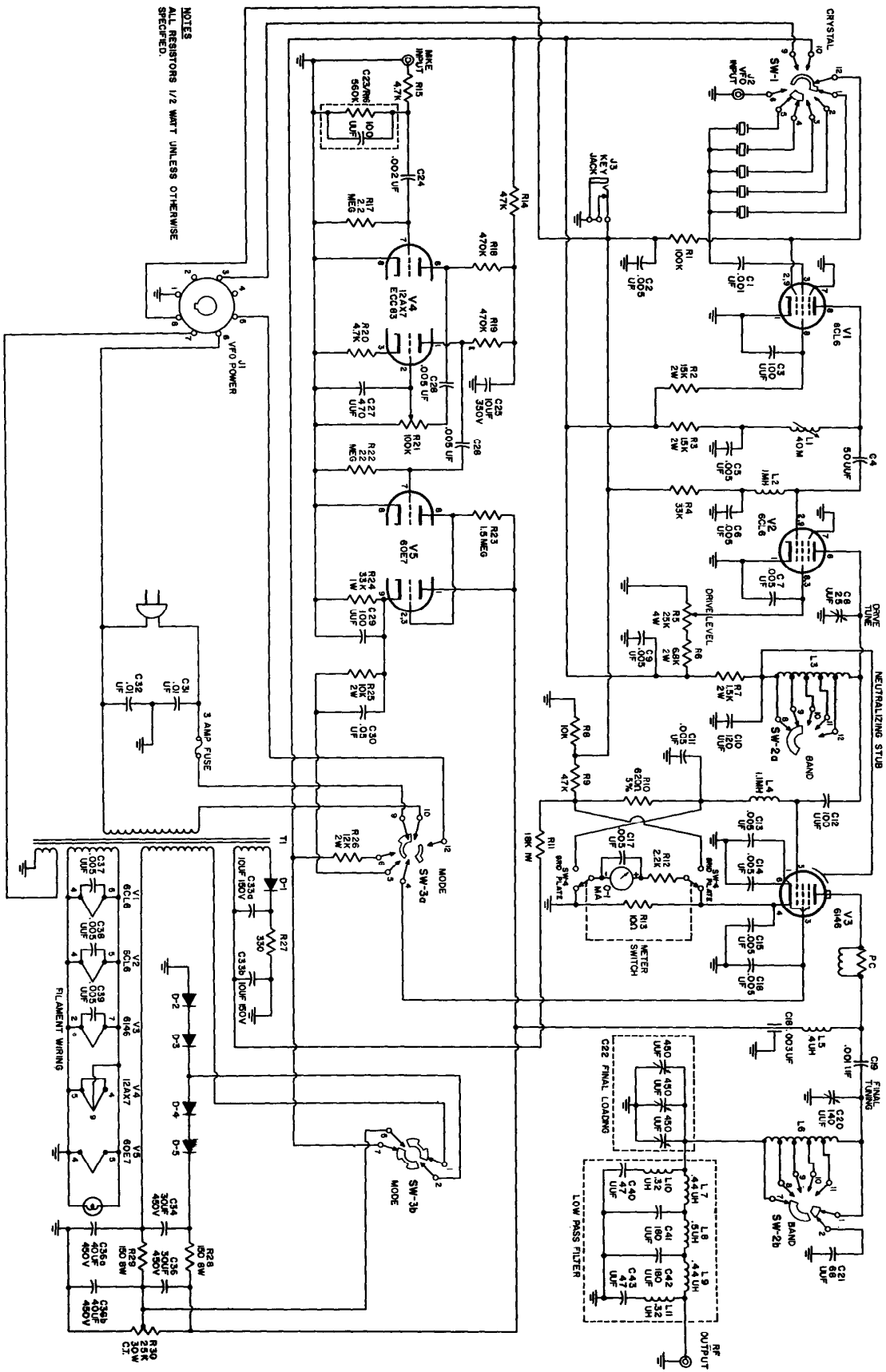

NOTES
 ALL RESISTORS 1/2 WATT UNLESS OTHERWISE
 SPECIFIED.

SCHEMATIC DIAGRAM