

KENWOOD

SERVICE MANUAL

TS-440S PS-50, PS-430, SP-430, MB-430, VS-1
AT-440, YK-88C/CN, YK-88S/SN

HF TRANCEIVER



CONTENTS

SPECIFICATIONS	2	PACKING	88
CIRCUIT DESCRIPTION	4	ADJUSTMENT	89
SEMICONDUCTORS	27	LEVEL DIAGRAM	101
PARTS LIST	35	BLOCK DIAGRAM	103
PC BOARD SCHEMATIC DIAGRAM		OPTION	
SWITCH UNIT	69	PS-50	104
FILTER UNIT	70, 71	PS-430	109
PLL UNIT	72, 73	VS-1	111
RF UNIT	74, 75	SP-430	114
CONTROL UNIT	76, 77	MB-430	114
DISPLAY UNIT	76, 77	AT-440	114
FINAL UNIT	78	YK-88S/SN	114
IF UNIT	78, 79	YK-88C/CN	114
AT UNIT	80	SCHEMATIC DIAGRAM	113
DISASSEMBLY	81		

SPECIFICATIONS

(GENERAL)

Transmitter frequency range:

160m BAND 1.8 ~ 2.0MHz
 80m BAND 3.5 ~ 4.0MHz
 40m BAND 7.0 ~ 7.3MHz
 30m BAND 10.1 ~ 10.15MHz
 20m BAND 14.0 ~ 14.35MHz
 17m BAND 18.068 ~ 18.168MHz
 15m BAND 21.0 ~ 21.45MHz
 12m BAND 24.89 ~ 24.99MHz
 10m BAND 28.0 ~ 29.7MHz

Receive frequency range:

100kHz ~ 30MHz

Mode:

A1(CW), A3J(SSB), A3(AM), F1(FSK), F3(FM)

Antenna impedance:

50 Ohm (TX: 20 ~ 150 Ohm with AT)

Power requirement:

12.0 ~ 16.0V DC

Power consumption:

RX no signal input:

Approx. 1.9A

TX:

Approx. 20A

Frequency configuration:

RX unit:

1st IF 45.05MHz, 2nd IF 8.83MHz, 3rd IF 455kHz

**TX unit: (A1,A3J,A3,FSK)
(F3)**

1st IF 455kHz, 2nd IF 8.83MHz, 3rd IF 45.05MHz

1st IF 36.22MHz, 2nd IF 45.05MHz

CW, SSB, AM, FSK, FM: Triple conversion superheterodyne

FM: Double conversion superheterodyne

Semiconductors:

	TS-440S	TS-440S (with AT)
Tr's	157	174
FET's	22	22
IC's	49	58
Diod's	257	277

Dimensions:

	TS-440S	TS-440S (with AT)
W(mm)	270 (279)	270 (279)
H(mm)	96 (108)	96 (108)
D(mm)	313 (335)	313 (335)
Weight(kg)	6.3	7.3

The numbers in the parenthesis include protections.

(TRANSMITTER)

Rated final power input:

Band \ Mode	A1, A3J, F1, F3	A3
1.8 ~ 28 MHz	200 W PEP	110 W PEP

Carrier suppression:

More than 40dB

Unwanted sideband suppression:

More than 50dB

Harmonic content:

Less than -40dB

Transmit frequency character:

400 ~ 2600Hz (-6dB)

Maximum frequency deviation (FM):

±5kHz

Microphone impedance:

500Ω ~ 50kΩ

SPECIFICATIONS

(RECEIVER)

Sensitivity:

Mode \ Freq.	100 ~ 150kHz	150 ~ 500kHz	0.5 ~ 1.6MHz	1.6 ~ 30MHz
SSB,CW,FSK (S/N10dB)	Less than 2.5 μ V (8dB μ)	Less than 1 μ V (0dB μ)	Less than 4 μ V (12dB μ)	Less than 0.25 μ V (-12dB μ)
AM (S/N10dB)	Less than 25 μ V (28dB μ)	Less than 13 μ V (22dB μ)	Less than 40 μ V (32dB μ)	Less than 2.5 μ V (8dB μ)
FM (12dB SINAD)	—	—	—	Less than 0.7 μ V (-3 dB μ)

Squelch sensitivity: (Threshold)

Mode \ Freq.	100 ~ 150kHz	150 ~ 500kHz	0.5 ~ 1.6MHz	1.6 ~ 30MHz
SSB,CW,AM,FSK	Less than 20 μ V (26dB μ)	Less than 10 μ V (20dB μ)	Less than 20 μ V (26dB μ)	Less than 2 μ V (6dB μ)
FM	—	—	—	Less than 0.32 μ V (-10dB μ)

Image ratio:

50dB or more (100kHz ~ 1.6MHz)
70dB or more (1.6 ~ 30MHz)

IF rejection:

50dB or more (FM 3rd image ratio)
50dB or more (100kHz ~ 1.6MHz)
70dB or more (1.6MHz ~ 30MHz)

Selectivity:

Mode \ Freq.	-6dB	-60dB
SB,CW,FSK	More than 2kHz	Less than 4.4kHz
AM	More than 4kHz	Less than 18kHz (-50dB)
FM	More than 12kHz	Less than 25kHz (-50dB)

IF SHIFT variable range:

\pm 0.9kHz or more

RIT/XIT variable range:

\pm 1kHz or more

Audio output power:

1.5W or more (with 8 Ω load, 10% distortion)

Audio output impedance

4 ~ 16 Ω (Speaker and headphone)

(FREQUENCY STABILITY)

Frequency accuracy: (RIT/XIT OFF)

More than $\pm 10 \times 10^{-6}$

Frequency stability:

More than $\pm 10 \times 10^{-6}$ (-10°C to 50°C)

(RIT/XIT OFF: at receive)

Reference oscillator frequency:

36MHz

Note: Circuit and ratings subject to change without notice due to developments in technology.

CIRCUIT DESCRIPTION

1. Overview

- The TS-440 is a triple conversion type transceiver, incorporating a general coverage receiver, which uses 45.05 MHz as the first IF, 8.83 MHz as the second IF, and 455 kHz as the third IF.
- The TS-440 is compact, but allows for installation of an optional internal automatic antenna tuner operating in the amateur band from 3.5 MHz to 28 MHz and enables a wide range of antennas to be used.
- The TS-440 also contains a microprocessor-controlled digital PLL circuit which controls frequency in 10 Hz steps using a single crystal oscillator to implement high accuracy and stable frequency control.
- The TS-440 has the following major features:
 - (1) Selectable VFOs; VFO-A and VFO-B
 - (2) Direct frequency input using a numeric keypad
 - (3) 100-channel memory containing frequency band, and mode information (channel 90 to 99 for split fre-

- quency memory)
- (4) Memory scan in 10 channel groups and two types of program scan
- (5) RTTY (AFSK) mode available
- (6) Squelch circuit operational in all modes
- (7) Dual filters available to improve selectivity and S/N ratio (optional filter required)
- (8) IF shift, audio notch, IF filter switching, and RF ATT functions for convenient interference reduction
- (9) Large heat sink and cooling fan (100 W) enabling up to one-hour continuous transmit operation
- (10) Full and semi break-in circuits for CW
- (11) External-computer controllable (optional interface required)
- (12) Many easy-to-read meter functions such as the received signal strength (s-meter), transmitter power, SWR, and ALC level.

2. Frequency Elements

The TS-440 utilizes a triple conversion transmitter and receiver.

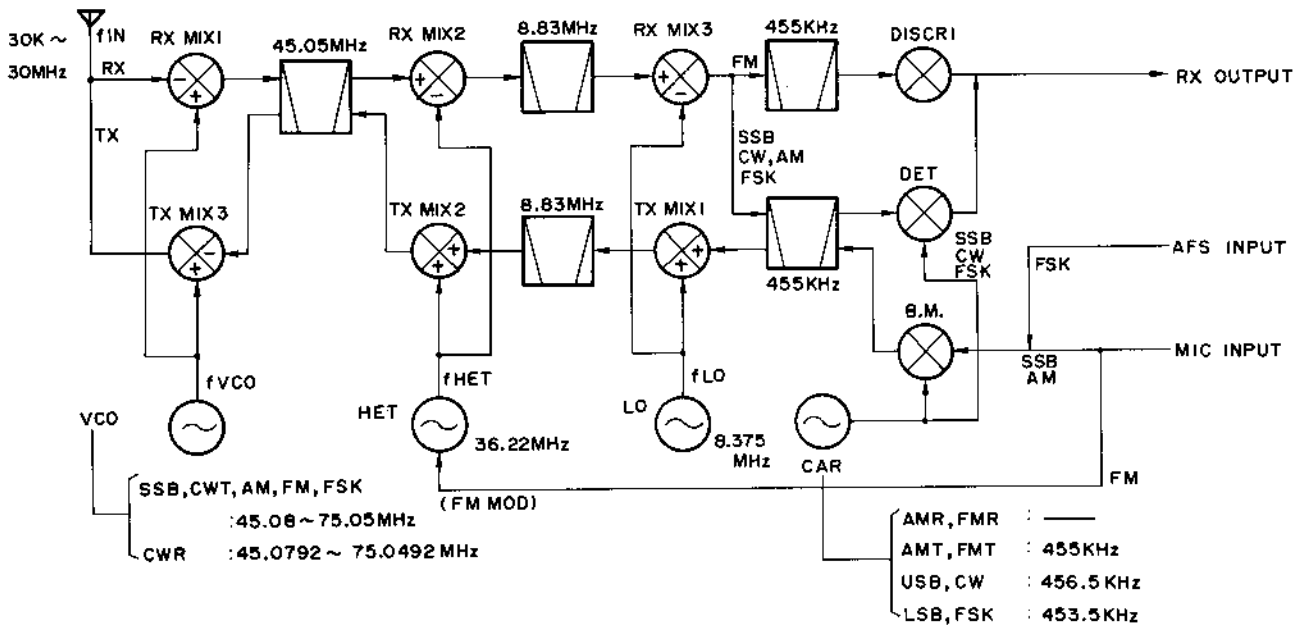

Fig. 1 Frequency configuration

The overall frequency configuration of the TS-440 is shown in Figure 1. The incoming received signal (f_{IN}) is applied to the ANT terminal. This signal is mixed with the local oscillator signal (f_{VCO}) in RX MIX 1 to obtain the first IF frequency. This signal is then mixed with the HET Oscillator signal (f_{HET}) in RX MIX 2 to obtain the 2nd IF frequency. This

signal is then combined with the CAR signal for detection. f_{IN} is expressed mathematically as follows:

$$f_{IN} = f_{VCO} - f_{HET} - f_{LO} - f_{CAR} \dots \dots \dots 1$$

CIRCUIT DESCRIPTION

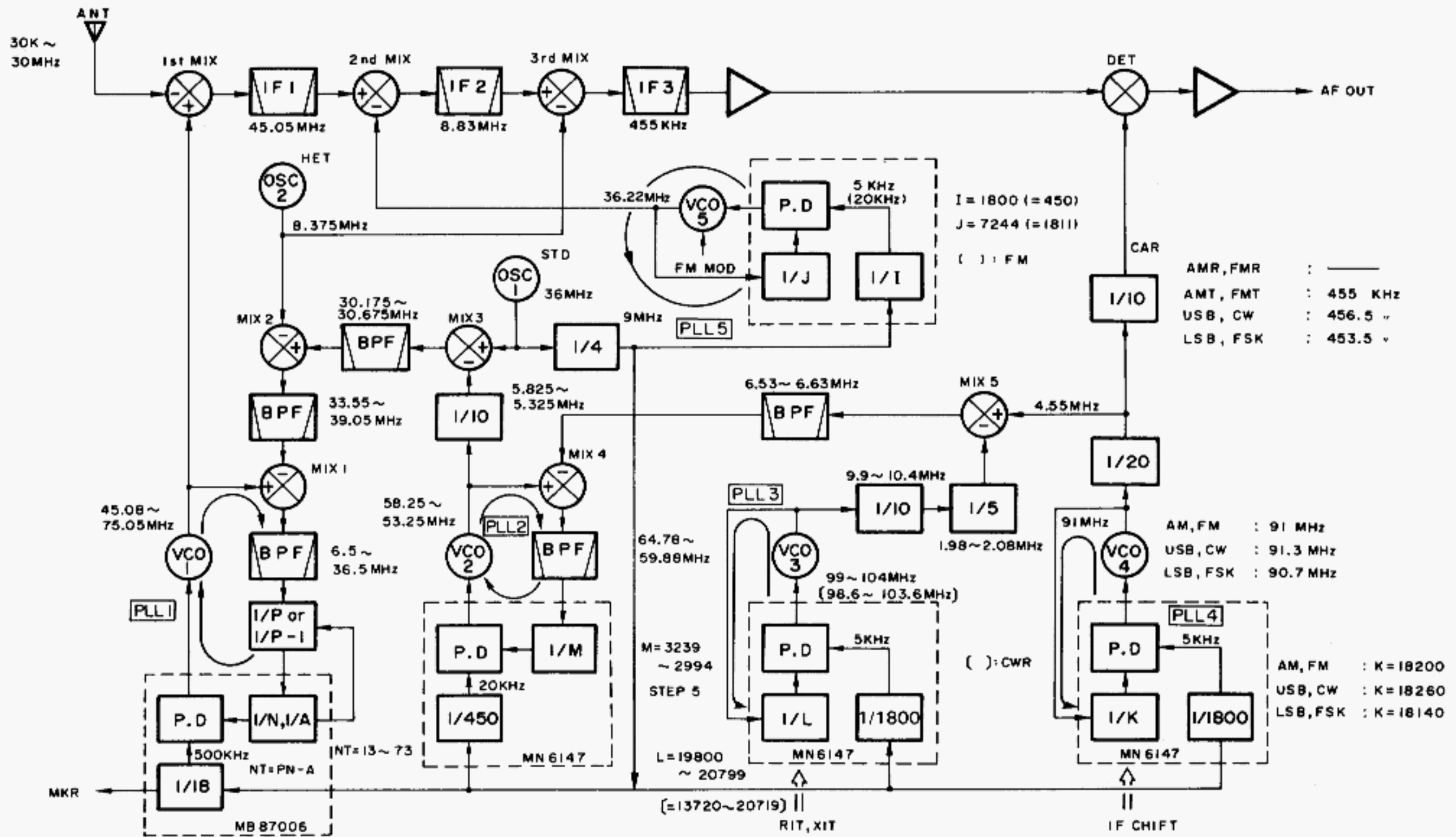

Fig. 2 PLL frequency configuration

As shown in figure 2, all received frequencies excluding the local oscillator frequency f_{LO} are generated in the PLL circuit. The frequencies generated in these loops are expressed as follows:

$$VCO5: \frac{f_{VCO5}}{J} = \frac{1}{4} \cdot f_{STD} \quad \therefore f_{VCO5} = \frac{J}{4I} f_{STD} \dots\dots 2$$

$$VCO4: \frac{f_{VCO4}}{K} = \frac{1}{4} \cdot f_{STD} \quad \therefore f_{VCO4} = \frac{K}{7200} f_{STD} \dots\dots 3$$

$$VCO3: \frac{f_{VCO3}}{L} = \frac{1}{4} \cdot f_{STD} \quad \therefore f_{VCO3} = \frac{L}{7200} f_{STD} \dots\dots 4$$

$$VCO2: \frac{f_{VCO2} + \frac{f_{VCO3}}{50} + \frac{f_{VCO4}}{20}}{M} = \frac{1}{4} \cdot f_{STD}$$

$$\therefore f_{VCO2} = \frac{M}{1800} \cdot f_{STD} - \frac{f_{VCO3}}{50} - \frac{f_{VCO4}}{20} \dots\dots 5$$

$$VCO1: \frac{f_{VCO1} - f_{LO} - f_{STD} + \frac{f_{VCO2}}{10}}{N} = \frac{1}{4} \cdot f_{STD}$$

$$\therefore f_{VCO1} = \frac{N}{72} f_{STD} + f_{LO} + f_{STD} - \frac{f_{VCO2}}{10} \dots\dots 6$$

Based on these formulas, the frequencies f_{VCO} , f_{HET} , and f_{CAR} are expressed as follows:

$$+ \frac{K}{1440000} + 1) \cdot f_{STD} + f_{LO} \dots\dots 7$$

$$f_{HET} = f_{VCO5} = \frac{J}{4I} \cdot f_{STD} \dots\dots 8$$

$$f_{CAR} = \frac{f_{VCO4}}{200} = \frac{K}{1440000} f_{STD} \dots\dots 9$$

Formula 1 may now be rewritten as follows:

$$f_{IN} = \left(\frac{N}{72} - \frac{M}{180000} + \frac{L}{3600000} - \frac{J}{4I} + 1 \right) \cdot f_{STD} \dots\dots 10$$

Note that f_{LO} is not included in formula 10. That is, a received frequency is determined by the reference frequency f_{STD} and frequency division data I to N. Further analysis of formula 10 shows the following:

- i) Basically, frequency division data I to N contain no error because they are controlled by the microprocessor according to the operating frequency.
- ii) The accuracy of the operating frequency is equal to that of the reference frequency, because all frequencies other than f_{STD} in formula 10 are determined by the microprocessor.
- iii) The operating frequency does not change even if k or f_{LO} changes.

CIRCUIT DESCRIPTION

$$I = 1800, J = 7244, K = 19800, L = 3239, M = 41$$

$$\therefore f_{IN} = 0.388 f_{STD} \dots\dots\dots 11$$

When $f_{IN} = 30$ MHz (USB mode) in formula 10, f_{IN} and f_{STD} have the following relationship:

$$I = 1800, J = 7244, K = 19800, L = 3239, M = 73$$

$$\therefore f_{IN} = 0.833 f_{STD} \dots\dots\dots 12$$

Since the precision of the reference crystal oscillator used in the TS-440 is 10 ppm (-10 to 50°C) and the receiver system has the characteristics shown in items i) and ii), the total accuracy is stable at any point from 30 kHz to 30 MHz. The maximum amount of frequency shift is only ± 300 Hz (see formula 12). The characteristic shown in item iii) enables variable band functions such as IF shift to be implemented, using the microprocessor. The microprocessor also is used to set carrier points by adjusting f_{CAR} , and to set and adjust the amount of IF shift.

So far received frequencies in the SSB mode have been dis-

cussed. For receive modes other than SSB, and in transmit mode, operating frequency is determined by the reference frequency and frequency division data.

In CW receive mode, f_{VCO} is shifted down 800 Hz and used as f_{VCO3} . In AM or FM receive mode, f_{CAR} generation is stopped. In FM receive mode, f_{HET} is modulated by adding audio signals to VCO5 from the microphone. FSK (RTTY) is transmitted in LSB mode and uses AFSK by adding audio signals externally.

The type of frequency displayed differs, depending on the mode, as shown in Table 1.

Mode	Displayed frequency
USB, LSB, FSK	Carrier point frequency
CW	Transmission carrier frequency
AM, FM	IF filter center frequency

Table 1 Displayed frequencies

3. Receiver Circuit Description

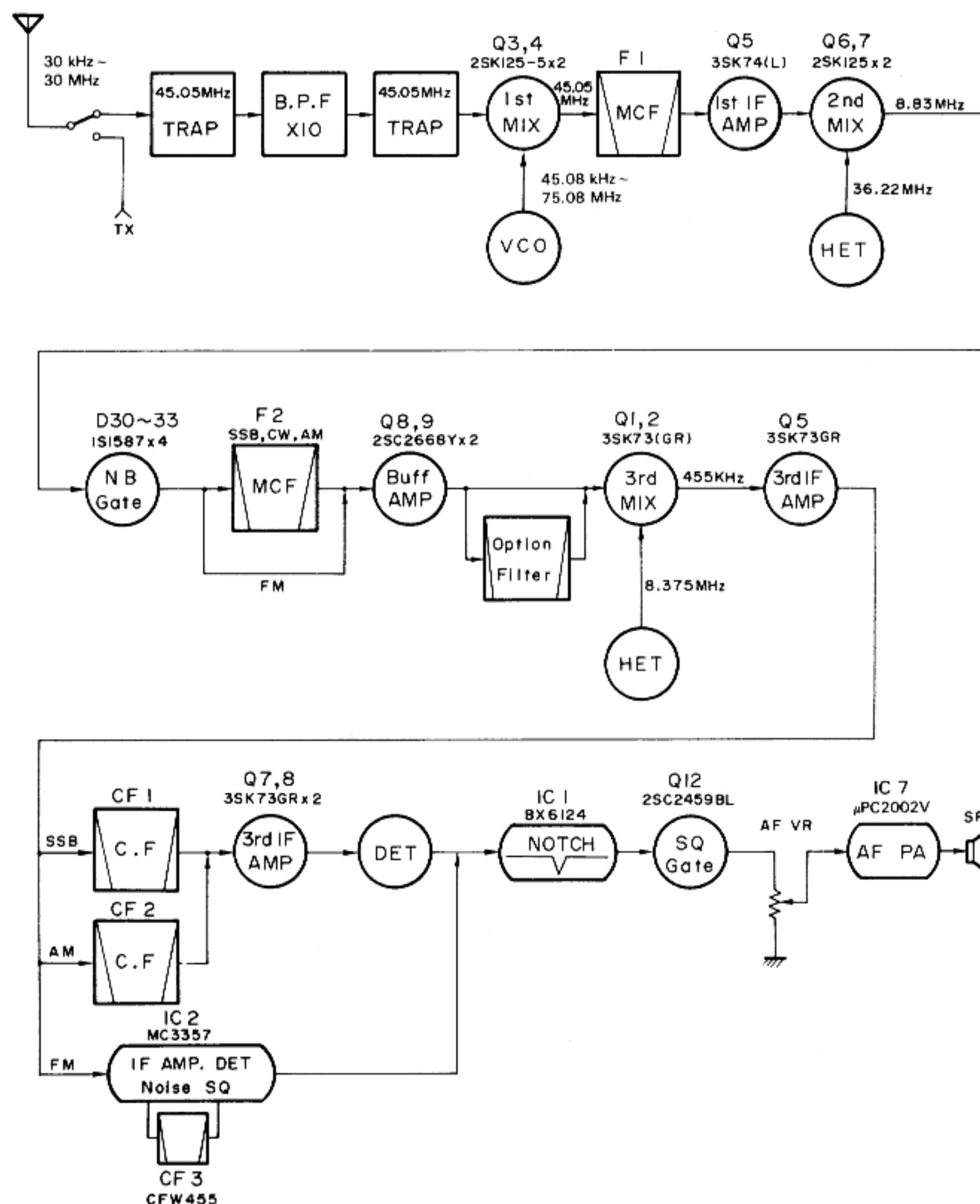

CIRCUIT DESCRIPTION

Signals from the ANT pin are fed into the RAT pin of the RF unit via the transmit/receive switching relay. The signals then go to the 10 BPFs through the approx. 20 dB attenuator circuit, the first stage of the first IF trap circuit, and the low pass filters (which pass only 500 kHz or less). The signal then goes through the second stage of the first IF trap circuit, and is mixed with the VCO signal and converted into the first IF signal of 45.05 MHz in the first mixer, consisting of Q3 and Q4 (2SK125-5). The VCO circuit consists of Q21 to Q24 (2SC2668Y) and oscillates in four bands from 45.05 MHz to 75.05 MHz. Oscillator frequencies are controlled by DC signals from the PLL unit.

The first IF signal of 45.05 MHz is passed through the MCF (F1), which is used in both receive and transmit, and is amplified by the first IF amplifier Q5 (3SK74L). In the second mixer, consisting of Q6 and Q7 (2SK125), the first IF signal is mixed with the heterodyne oscillator signal (36.22 MHz) from the PLL circuit, amplified by Q12 (2SC2668Y) to obtain the second IF signal (8.83 MHz). The second IF signal of 8.83 MHz goes through the gate of the noise blanker. In modes other than FM, the signal then goes through the MCF (F2) and is fed into the IF unit through buffer amplifiers Q8 and Q9 (2SC2668Y).

When the optional 8.83 MHz filter is connected, the second IF signal is then fed from the IF unit into the optional filter. In the third mixer, consisting of Q1 and Q2 (3SK73GR), the second IF signal is mixed with 8.375 MHz signal generated by IF unit's heterodyne oscillator circuit, consisting of Q53 and Q54 (2SC2458Y), and converted into the third IF signal (455 kHz). The third IF signal is then amplified by Q5 (3SK73GR). A diode switch is used to route the signal to either the FM or SSB circuits.

In SSB mode, the third IF signal goes through the SSB ceramic filter (XF3). In AM mode, the third IF signal goes through the AM ceramic filter (XF4). In either mode, the third IF signal is then amplified by Q7 and Q8 (3SK73GR) and detected. In FM mode, the third IF signal goes through the FM ceramic filter (XF5). The signal is then sent to the FM IF, IC2 (MC 3357) for amplification and detection. IC2 also contains an FM noise squelch circuit.

The detected SSB/AM signal is passed through the notch circuit, consisting of hybrid IC IC1 (BX6124) and squelch gate Q12 (2SC2459BL). The signal then goes through the AF volume control and is amplified to the appropriate level by AF amplifier IC7 (UPC2002V).

1) Selectivity circuit

Figure 4 is a selectivity circuit diagram. In auto mode, the appropriate bandwidth filter is automatically selected according to mode. When an optional filter is used, two filters are available. Tables 2 and 3 shows the various combinations

of bandwidth available when optional filters are used. In FM mode, the selectivity switch does not operate and a single dedicated FM filter is used. Optional filters operate only in receive and are separate from the filters used in transmit.

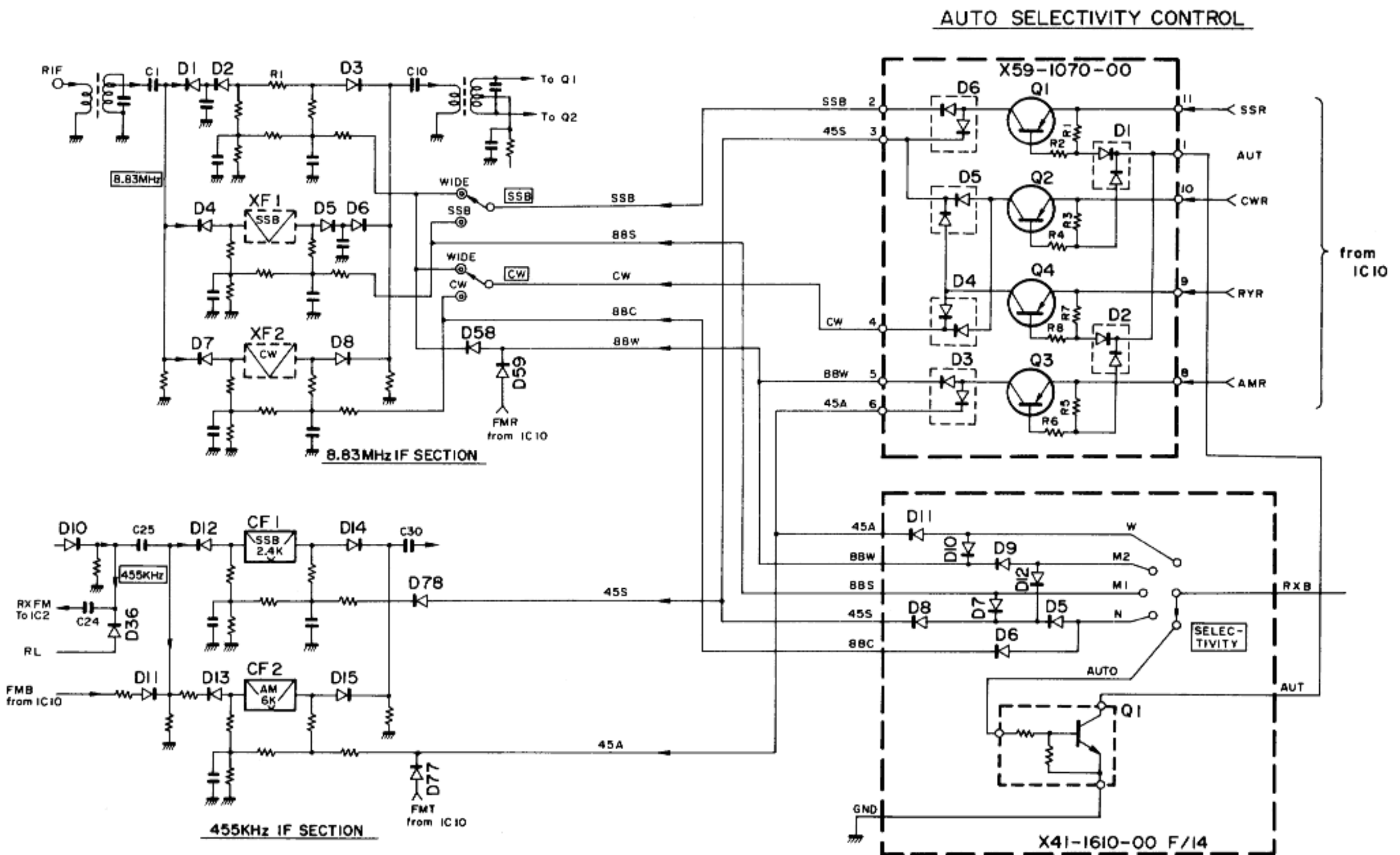

CIRCUIT DESCRIPTION

Filter selective

AUTO MODE

MODE	WITHOUT OPTION		OPTION INSTALLED	
	8.83MHz	455kHz	8.83MHz	455kHz
SSB	Through	CF1	XF1	CF1
CW	Through	CF1	XF2	CF1
AM	Through	CF2	Through	CF2
FSK	Through	CF1	XF2	CF1
FM	Through	—	Through	—

XF1: YK-88S or YK-88SN
XF2: YK-88C or YK-88CN

Table 2

Item	Rating
Center frequency f_0	45.05 MHz
Center frequency deviation	$f_0 \pm 1$ kHz at 3 dB
Pass bandwidth	± 9.6 kHz or more at 3 dB
Attenuation bandwidth	± 28 kHz or less at 10 dB
Ripple	0.7 dB or less
Insertion loss	2.0 dB or less
Guaranteed attenuation	30 dB or more with ± 1 MHz (Except spurious)
Final impedance	$2 \text{ k}\Omega \pm 10\%$ /L characteristic

Table 4 MCF (L71-0259-05) (RF UNIT F1)

Item	Rating
Center frequency f_0	$8830 \text{ kHz} \pm 0.5 \text{ kHz}$
Pass bandwidth	± 3 kHz or more at 3 dB
Attenuation bandwidth	± 12 kHz or less at 18 dB
Guaranteed attenuation	30 dB or more within $f_0 \pm 1$ MHz
Ripple	0.5 dB or less
Insertion loss	1.0 dB or less
Final impedance	$2.5 \text{ k}\Omega / 3 \text{ pF}$

Table 6 MCF (L72-0260-05) (RF unit F2)

Item	Rating
Center frequency f_0	$455 \text{ kHz} \pm 0.2 \text{ kHz}$ at 6 dB
6 dB bandwidth (total)	$\pm 1.1 \sim 1.3$ kHz
60 dB bandwidth	4.5 kHz or less
Guaranteed attenuation	60 dB or more (at 0.1 ~ 1 MHz)
Spurious (600 ~ 700 kHz)	40 dB or more
Ripple with bandwidth	2 dB or less at 60 dB
Insertion loss	2 dB or less
Temperature	$-10^\circ\text{C} \sim +50^\circ\text{C}$
Input and output impedance	$2 \text{ k}\Omega$

MANUAL MODE

SELECT	WITHOUT OPTION		OPTION INSTALLED	
	8.83MHz	455kHz	8.83MHz	455kHz
N	NO RX		XF2	CF1
M1			XF1	CF1
M2	Through	CF1	Through	CF1
W	Through	CF2	Through	CF2

XF1: YK-88S or YK-88SN
XF2: YK-88C or YK-88CN

Table 3

Item	Rating
Center frequency f_0	455 kHz
6 dB bandwidth	± 2 kHz or more
40 dB bandwidth	7.5 kHz or less
Insertion loss	6 dB or less
Guaranteed attenuation (within 455kHz ± 100 kHz)	35 dB or more
Input and output impedance	$2.0 \text{ k}\Omega$

Table 5 Ceramic filter (L72-0355-05) (IF UNIT CF2)

Item	Rating
Center frequency f_0	$455 \text{ kHz} \pm 1 \text{ kHz}$
6 dB bandwidth	± 6 kHz or more
50 dB bandwidth	± 12.5 kHz or less
Ripple (within 455 kHz ± 4 kHz)	3 dB or less
Insertion loss	6 dB or less
Guaranteed attenuation (within 455 kHz ± 100 kHz)	35 dB or more
Input and output impedance	$2.0 \text{ k}\Omega$

Table 7 Ceramic filter (L72-0315-05) (IF unit CF3)

Item	Rating
Center frequency f_0	8.830 MHz
Attenuation bandwidth	± 50 kHz or more at 3 dB
Guaranteed attenuation	35 dB or more at 9.285 MHz 45 dB or more at 9.74 MHz
Insertion loss	6 dB or less
Ripple	1.0 dB or less
Input and output impedance	330Ω
Max. voltage (DC)	50 V (Min.)

CIRCUIT DESCRIPTION

2) AF notch circuit

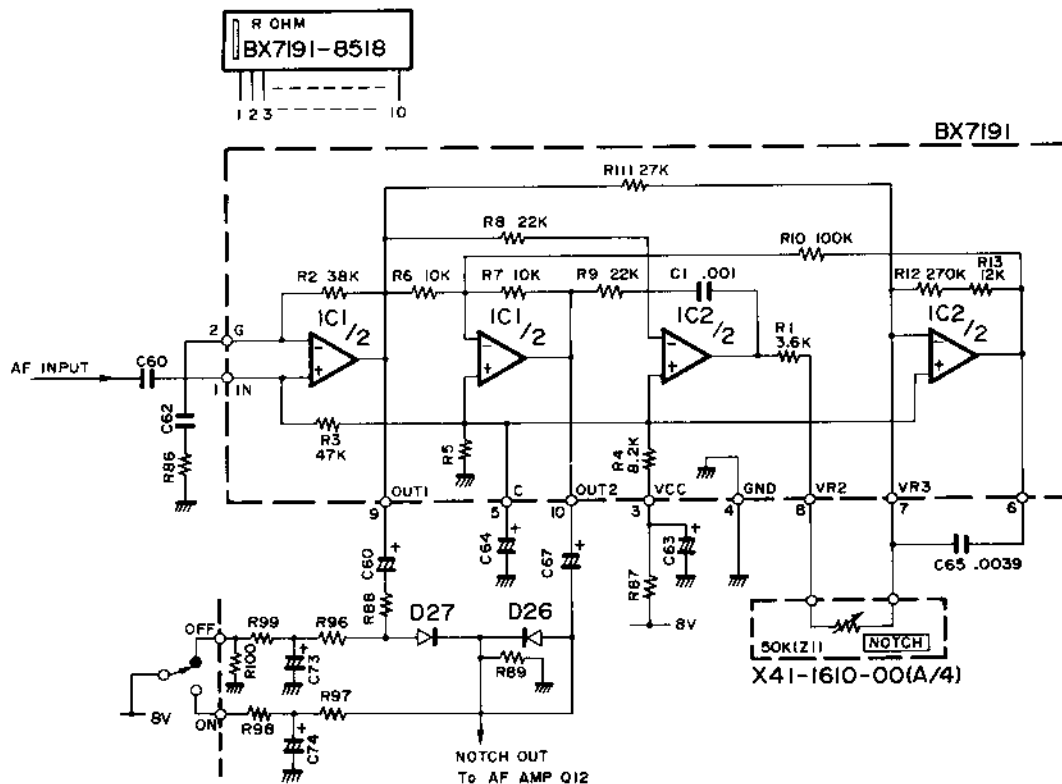

Fig. 5 NOTCH circuit

The hybrid IC1 in the IF unit is an audio notch circuit. Figure 5 shows its equivalent circuit. This circuit forms state-variable bandpass filter, also known as a bi-quad filter. The notch frequency can be changed using the notch control variable resistor. Since the circuit consists of the hybrid IC, stable attenuation characteristics can be obtained electrically and thermally. The range of variable notch frequencies is 400 Hz to 2600 Hz.

The notch frequency is determined by the following two formulas.

- 1) $f_N \cong \sqrt{R6/2\pi} \cdot \sqrt{(R1 + \text{Notch VR}) \cdot R8 \cdot R10 \cdot C1 \cdot C65}$ 1
- 2) $R6 \cdot (R12 + R13) \cong R10 \cdot R11$ 2

If a variable resistor is used for resistor NOTCH VR, the notch frequency can be controlled according to formula 1). The notch frequency range is from 400 to 2600 Hz, and attenuation is from 25 to 50 dB.

CIRCUIT DESCRIPTION

3. Transmitter Circuit Description

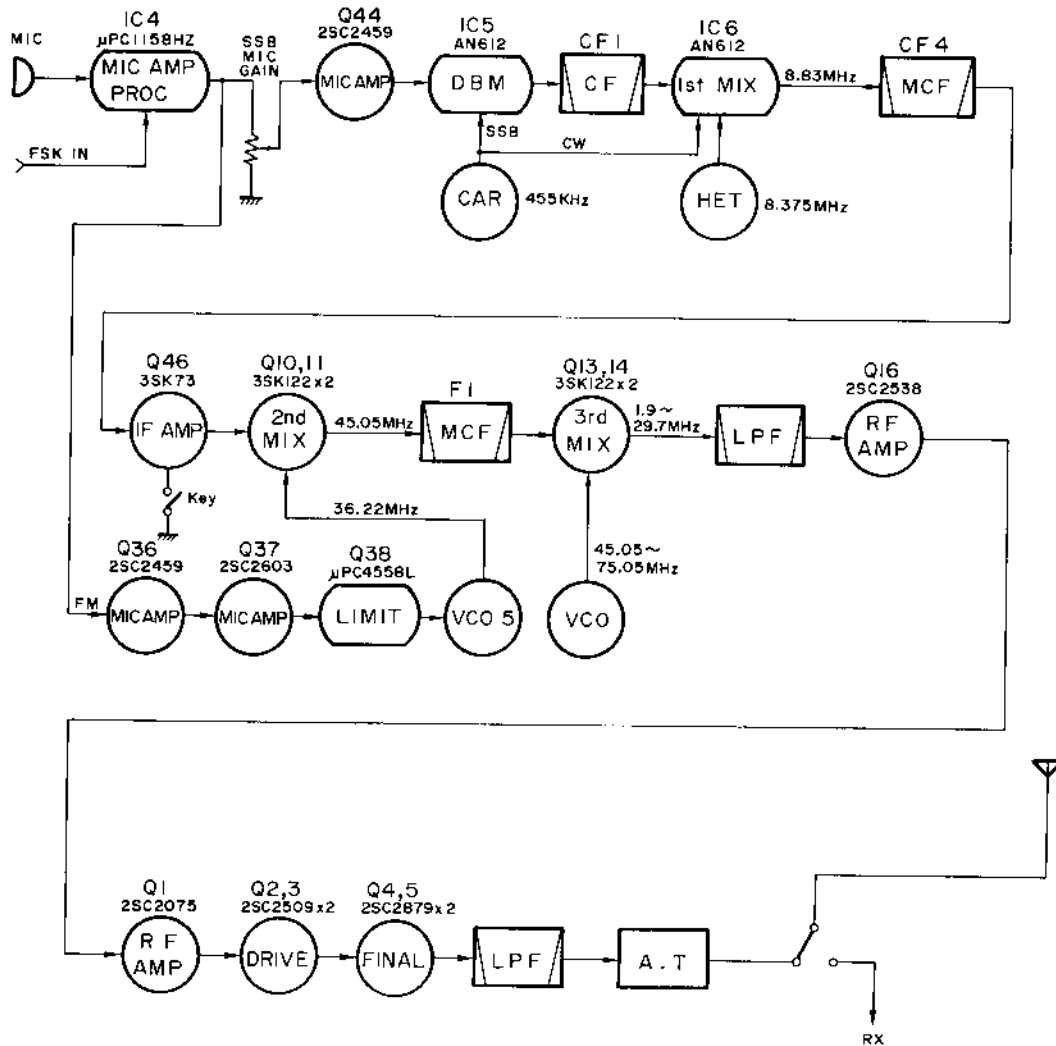

Fig. 6 Transmitter circuit configuration

In SSB, CW, AM, or FSK mode, the transmitter system uses triple conversion. In FM mode, the transmitter system uses double conversion using PLL modulation.

Audio signals from the microphone are applied to the MIC pin (connector (21)) of the IF unit and are separated into SSB modulation and VOX signals. The SSB signal is amplified approx. 8 dB by IC4 (μPC1158HZ). AFSK audio signals from the AFSK IN pin (back panel) are also applied to IC4.

IC4 functions as a SPEECH processor. Output from IC4 is distributed to the MIC GAIN control (front panel) and FM circuit (RF unit). In SSB mode, the signal applied to the MIC GAIN control is sent back to the IF unit (connector (23) MV2), amplified by Q44 (2SC2459), and supplied to the balanced modulator IC5 (AN612). In FM or CW mode, Q44 does not operate because a cut-off voltage is supplied to its emitter via diodes D82 and D46. The signal converted to 455 kHz

CIRCUIT DESCRIPTION

DSB by IC4 goes through the SSB transmit switching diodes D17 and D18, filter switching diodes D14 and D12, and SSB ceramic filter CF1, to obtain the SSB signal. The SSB signal then goes through the transmit switching diode D36 and is fed into the transmit first mixer, IC6, where the SSB signal is mixed with the output from the 8.375 MHz oscillator in the IF unit, and converted to 8.83 MHz. In CW or FM mode, the carrier signal from the PLL unit does not go through IC5 BM or the 455 kHz filter. These carrier signals are applied to IC6 via switching diodes D53 and D54. The output signal from IC6 goes through the MCF to remove spurious components, and is amplified by the IF amplifier Q46 (3SK73) and sent to the RF unit. Q46 provides ALC control and CW keying.

In the transmitter second mixer, consisting of Q11 and Q12, (3SK122), the 8.83 MHz transmit IF signal input to the RF unit is mixed with HET oscillator signal (36.22 MHz) from the PLL unit and converted to 45.05 MHz signals. The 45.05 MHz signal goes through D23 and the MCF to remove any spurious components. The 45.05 MHz signal then goes through D27 and is supplied to the transmit third mixer consisting of Q13 and Q14 (3SK122). In the third mixer the signal is mixed with VCO signal (Q21 to Q24) amplified by Q12 (2SC2668) and converted to the required transmit frequency (1.8 to 29.7 MHz). The signal from the third mixer goes through the low pass filters C156, C158, C159, and L89, and is amplified by the wide band amplifier Q15 (2SC2570). The signal then goes through the wide band transformer T19 and low pass filters C164, C165, and L90, and is further amplified by wide band amplifier Q16 (2SC2538). The signal from the Q16 goes through the output transformer T20 and is used as the drive output.

In FM mode, the PLL VCO is directly modulated. The audio signal from IF unit IC4 (UPC1158HZ) is fed into the RF unit via the FMI pin. In the RF unit, the audio signal is amplified by Q36 (2SC2459) and Q37 (2SC2603), and goes through the limiter circuit consisting of Q38 (UPC4558C) and low pass filter circuit, and is sent to the PLL unit via the FMD pin. In the PLL unit, the 36.22 MHz VCO is modulated. Q39 (2SC2603) is a switching circuit to prevent the modulated signals from being emitted from the PLL unit in a mode other than FM.

For "S" model radios the output from the RF unit is amplified to a 100 W power level by Q1 (2SC2075), Q2 and Q3 (2SC2509), and Q4 and Q5 (2SC2879) in the final unit. The 100 W output goes through the LPFs which differ by bands, and is sent as output to the antenna via the AT unit and transmit/receive switching relay. SWR and ALC detection is performed at the output of the LPFs.

1) Antenna tuner

The antenna tuner operates when the AUTO/THRU switch is in the AUTO position and the AT TUNE switch is ON. The antenna tuner is driven in the CW mode and power is reduced to 50 W by the microcomputer regardless of the mode selected before the AT TUNE switch was turned ON. The range of operating frequencies is determined by a microcomputer program, and is from 3.5 MHz to 30 MHz.

• AT unit operation

Power transmitted by the final unit passes through the current and voltage detecting transformers L1 and L2 using toroidal cores. Current and voltage components detected by the transformers are supplied to pins 9 and 13 of IC2 for wave shaping and their phases are compared by IC3 HD10131. The output from pin 3 of IC3 depends upon the phase of the voltage and current waveforms applied to IC3. The signal from IC3 pin 3 is sent to pins 10 and 15 of buffer IC IC3 HD10125. Output from pins 12 and 13 of IC3 goes through level shift Zener diodes D5 and D6 to control the input circuit of motor drive IC IC5 BA6109U2. The output signal is used to drive motor M1 to adjust the variable capacitor VC1 so that the phase difference between voltage and current components is reduced.

The current and voltage components output from the current and voltage detecting transformers is also supplied to the voltage comparator IC1 NJM2903D. The comparator output is used by motor drive IC IC6 BA6109U2 to drive motor M2 to adjust variable capacitor VC2 so that the amplitude difference is reduced. That is, the phase control variable capacitor VC1 is controlled so that the current is in phase with the voltage and the voltage control variable capacitor VC2 is controlled so that the amount of amplitude difference between the current and voltage is reduced (SWR1, an SWR of 1 to 1, is obtained when the current and voltage are in phase and the amount of amplitude difference is 0). VC1 and VC2 are designed to operate independently of each other, but since phase difference affects the amount of amplitude difference and vice versa, VC1 and VC2 will normally rotate together.

Forward and reflected waves detected by the filter unit are converted to SWR control signals in the SWR arithmetic circuit in the control unit and are sent to the ISW pin of the AT unit. Since the SWR control signals are current waveforms, the signals are converted from I to V waveforms by IC8 (b/4) in the AT unit and to obtain the corresponding voltage mode SWR signals are generated. The SWR signals are then fed into the SWR comparator IC8 (C/4). The reference voltage pin 9 of the IC8 (C/4) is supplied with a voltage corresponding to an SWR of 1.25 to 1 via a potentiometer. Therefore, when the actual SWR value exceeds 1.25, pin 8 of SWR comparator IC8 (C/4) is H, so the motor drive voltage control transistor Q5 turns on and the collector of Q4 is supplied with voltage from pin 14S. The voltage is also used to turn the tuning LED on. The inverted input pin of IC8 (d/4) is supplied with triangular waves generated by IC7, and its non-inverted input pin is supplied with the above SWR vol-

CIRCUIT DESCRIPTION

waves changing from continuous waves to relatively low duty pulses. Q1 is driven by this voltage waveform to control Q2, which is connected to the collector of Q4 in series and motor drive voltage is generated.

If the motor turns too fast, the SWR value will be smaller than the motor stop value because of the inertia of the motor. As a result, the motor will continue to operate even if

the motor stop signal is sent and the SWR value will continue to be greater than the motor stop value, causing the motor stop signal to turn off. That is, the motor will not stop and it will be difficult to obtain a match. If the motor speed is too slow, it will take a long time to satisfy a matching condition. The TS-440 therefore controls the motor speed according to changes in SWR.

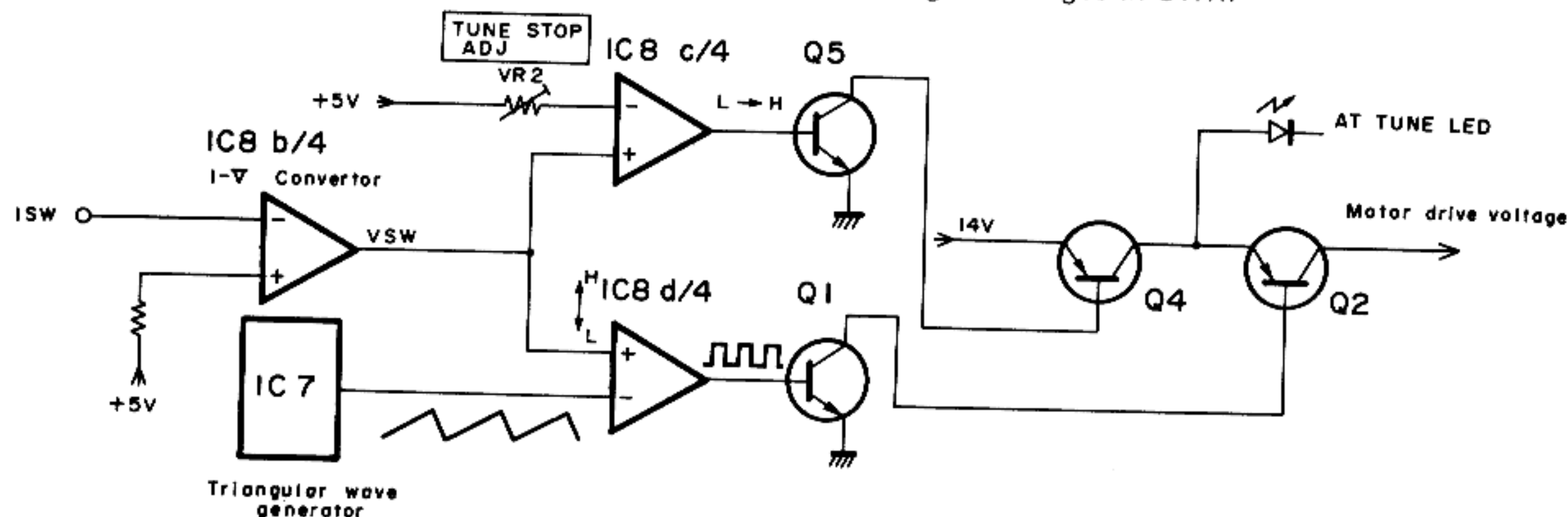

Fig. 7 Antenna tuner circuit

The antenna coupler is a T type. Six relays RL100 to RL105 are used to change taps within the range 3.5 MHz to 30 MHz.

2) Cooling fan circuit

The final unit contains the temperature-sensitive thermistor TH1 thermally coupled with final transistor Q4. When temperature on the surface of Q4 reaches approx. 50°C, the fan start comparator Q9B operates (H level), causing Q8 to turn on to operate the fan. During operation of the fan, temperature protection comparator Q9A is at a L level, so the temperature protection circuit does not operate.

When temperature on the surface of Q4 goes down to 45°C, the cooling fan turns off.

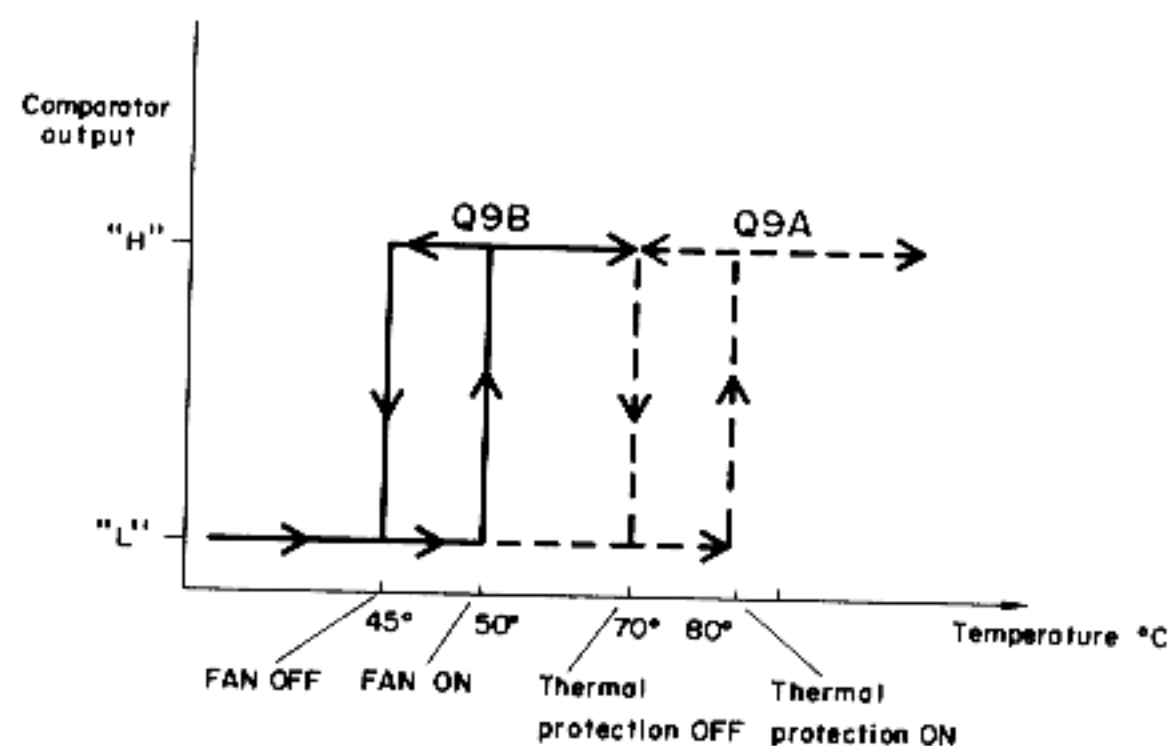

Fig. 8 temperature protection operation

- **Final temperature protection circuit**

When the temperature of the final transistor Q4 rises up to approx. 80°C, the temperature protection comparator Q9A turns on (H level), Q1 in the filter unit also turns on, and a minus DC voltage is supplied to the ALC line, reducing the transmitter output to zero. (The TS-440 does not return to a receive state.) When the temperature of the final transistor Q4 falls to approx. 70°C, the protection circuits turns off allowing the transmitter to operate again.

- **SWR protection circuit**

When antenna VSWR is bad, or the reflected wave is too large, because the auto antenna is tuning for example, L42 and L43 detect the state and its output is rectified. The rectified signal is then amplified by Q2 to control the ALC voltage so that drive power is reduced. As a result, load on the final unit is reduced.

- **SWR automatic arithmetic circuit**

The TS-440 uses the automatic arithmetic circuit in the AT-250. The forward wave voltage V_{SF} and reflected wave voltage V_{SR} from the filter unit are fed into the analog arithmetic circuit of the switch unit, and used to set the voltage level of IC8 pin 2 ($5V + V_{SR}/V_{SF}$). Output voltage from the pin 2 is shifted by IC5 to move the needle in the SWR meter.

IC5 contains a level shift/meter amplifier and an auto tuner V-I converter. IC7 contains a square wave generator and a voltage comparator. IC8 contains an integration circuit.

CIRCUIT DESCRIPTION

V_{SF} is compared with voltage from IC8 pin 6 (5.5 V). When SWR increases, V_{SF} lowers and the voltage level of IC8 pin 8 rises. At IC7 pin 3, a triangular wave is monitored. The triangular wave is compared with the wave from IC8 pin 8 and output. The triangular wave is converted to a square wave by IC10 and sent to switch Q3 and Q4. This voltage is used as the SWR control voltage.

Output voltage from IC8 pin 2 consists of the voltage compared with V_{SR}/V_{SF} and +5 DC voltage. It is distributed to IC4 the level shift/meter amplifier to move the needle in the SWR meter and IC5 the V-I convertor to control the AT440.

VR14 is used to adjust the SWR meter ZERO point. VR13 is for SWR meter adjustment

3) FULL/SEMI BREAK-IN and VOX circuits

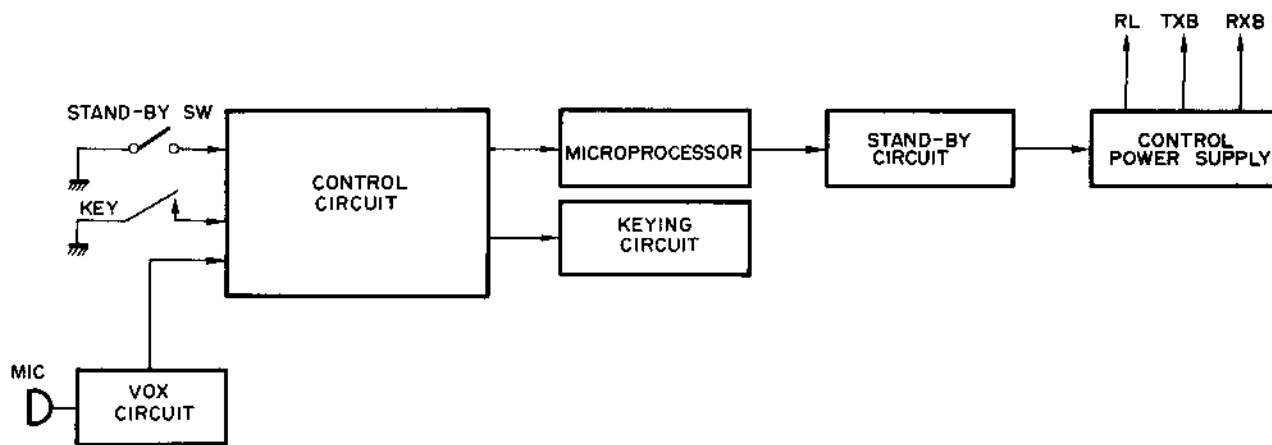
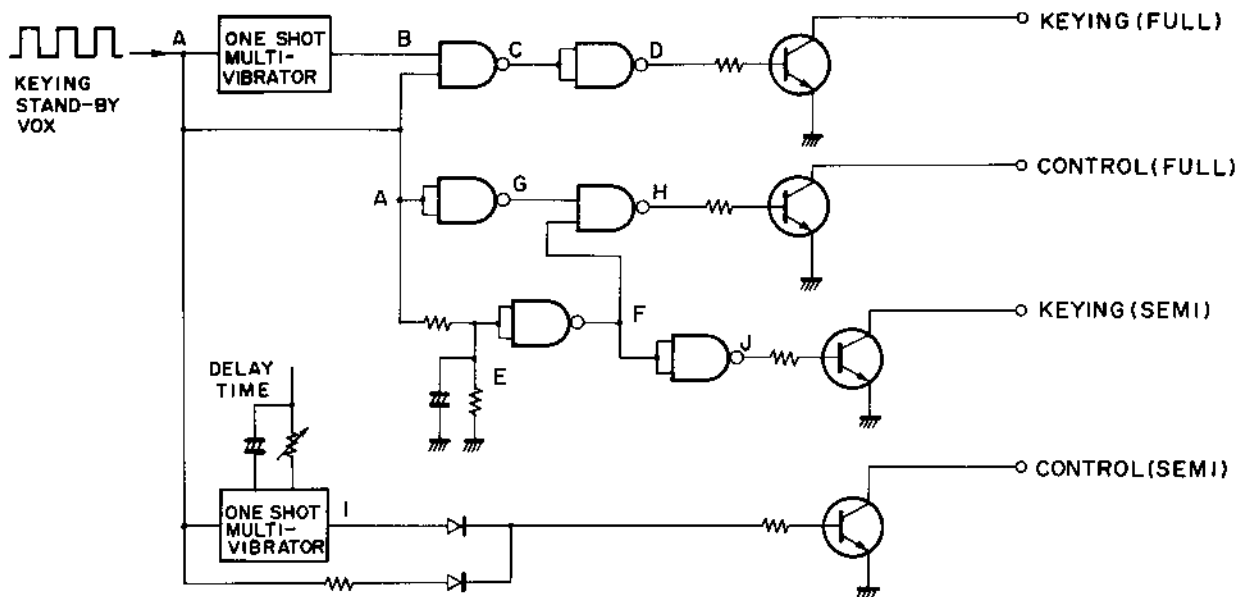

Fig. 9-1 FULL/SEMI BREAK-IN block diagram

When the standby switch, the key, or the VOX switching transistor are activated, a ground is applied to the input pin of the control circuit, which causes a standby signal to be fed to the microprocessor to determine if a valid transmit condition has been met. When that condition has been met, the

standby circuit in the IF unit will be turned on. A keying signal is generated by the control circuit, whenever the key is depressed, to control the keying circuits in the IF unit. This keying signal is also used as the transmit/receive signal during break-in operations.



CIRCUIT DESCRIPTION

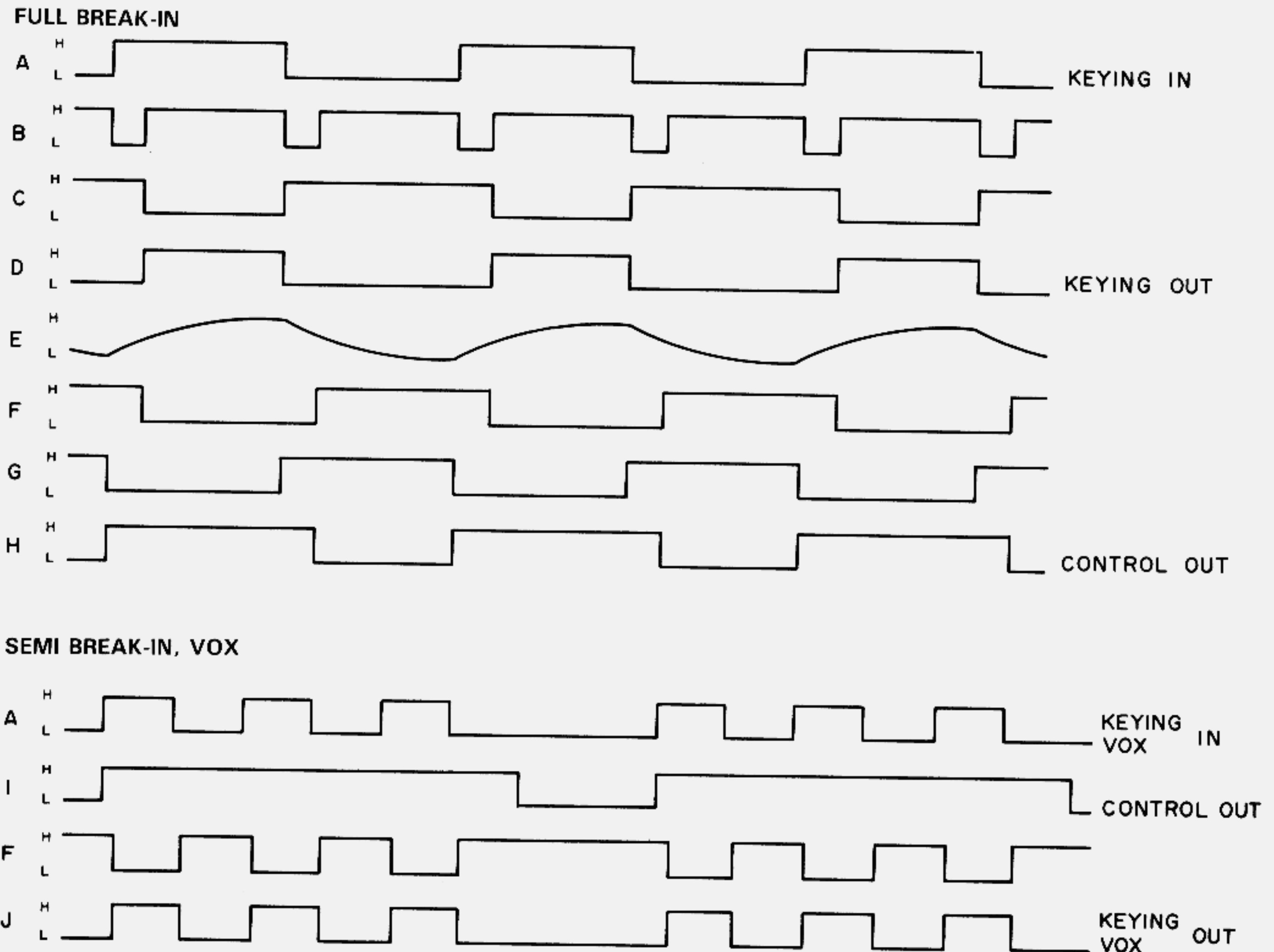

Fig. 9-3 FULL/SEMI BREAK-IN timing chart

The above timing charts show the timing for standby and keying signals.

When an input from the CW key is supplied to point A as shown in the above figure during full break-in operation, the one-shot multi-vibrator and gate circuits generate control (full) and delayed keying (full) signals. After the fundamental timing signal, RL (12V) for reception and transmission rises, the keying wave also rises, and when the key is off, RL falls according to the preset time constant.

Semi-break-in operation is synchronized to VOX. When a signal is supplied to point A, the VOX delay time multi-vibrator determines the VOX time constant. The input signal is converted to a keying (semi) signal by the gate circuit.

These keying semi/full and control semi/full signals are converted to appropriate break-in VOX mode signals us-

ing the slide switch. The control signal is checked by the microcomputer to see whether transmission is to be performed. The control signal is then used to switch CRL in the IF assembly unit and generate RL (12 V). TXB (transmit B+) (8.8 V) is generated, synchronized to RL. The receive control signal RXB (receive B+) (8.8 V) turns on/off, synchronized to the inverted TXB signal, that is, RL.



Fig. 10 STANDBY keying timing chart

CIRCUIT DESCRIPTION

4) Speech processor

IC4 in the IF unit functions as the first stage microphone amplifier or audio speech processor. When the processor switch is off, IC4 functions as a 20 dB microphone amplifier. When the processor switch is on, IC4 functions as an up to 40 dB

gain amplifier with ALC. When the processor switch is on, 8 VDC is supplied to the base of the gain adjustment switching transistor, Q41, driving the feedback amplifier.

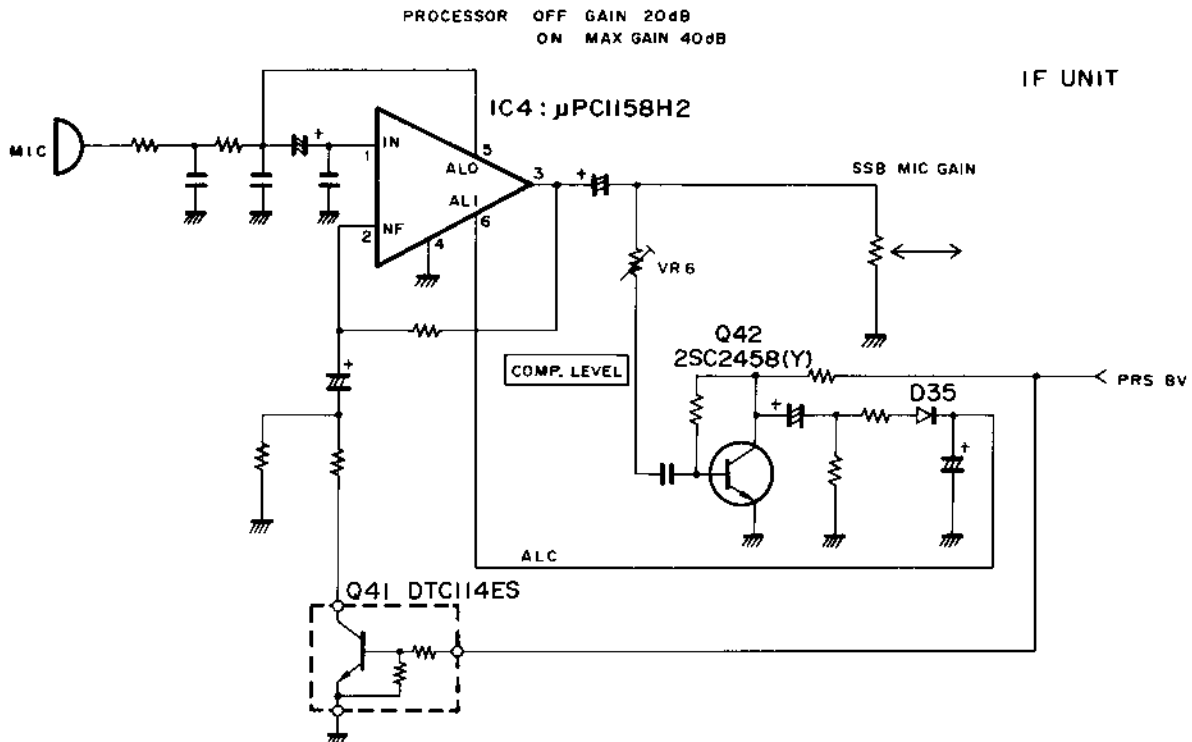

Fig. 11

4. PLL Circuits

Theory of PLL circuit operations

The TS-440 PLL circuit uses a reference frequency of 36 MHz and consists of five PLL loops covering the range of frequencies from 30 kHz to 30 MHz in 10 Hz steps. The PLL circuit has an IF shift function which is implemented by inserting carrier frequencies between PLL loops. The PLL loops include a carrier circuit PLL loop and an HET circuit PLL loop which generates a constant frequency of 36.22 MHz. Frequency division for these PLL loops is controlled by the microprocessor. In all PLL loops phase comparison is made using the reference frequency f_{STD} (frequency control using a single crystal oscillator).

Figure 12 is the PLL circuit block diagram.

The reference frequency (f_{STD}) is generated by a 36 MHz crystal oscillator and Q21 (2SC2787). Reference frequency signals are fed into the main loop's IC11 (SN16913P) via a buffer consisting of Q22 and Q23 (2SC2668). The signal is also fed into IC13 (SN74S112) via a buffer consisting of Q24 (2SC2668). In IC13, the signals are frequency divided to generate a 9 MHz signal. The 9 MHz signal is used as the

- PLL5

PLL5 consists of IC18 (MN6147) and its associated loop components. VC05, Q36 (2SK192A), is locked at a frequency of 36.22 MHz. The 9 MHz reference frequency signal is supplied to pin 3 of IC18, where the signal is divided by 1800 (450 in FM mode) to generate a 5 kHz (20 kHz in FM mode) signal used for comparison. VC05's output signal is supplied to IC18 pin 16 via Q37 (2SC2668), where the signals are frequency divided by 7244 (1811 in FM mode). The phase of the signal is then compared with that of the 5 kHz (20 kHz in FM mode) signal by the phase comparator and the VC05 oscillation frequency is locked. Frequency division data is supplied by digital unit (DA0 to DA3 and CK4).

As described above, the dividing ratio used varies depending on which mode the TS-440 is in, FM mode or SSB. This is because the apparent time constant is increased without changing the active LPF constant so that the PLL signals can be modulated easily and reducing distortion during FM transmission. In modes other than FM, the amount of frequency shift due to mechanical vibrations is reduced because the apparent time constant is reduced.

CIRCUIT DESCRIPTION

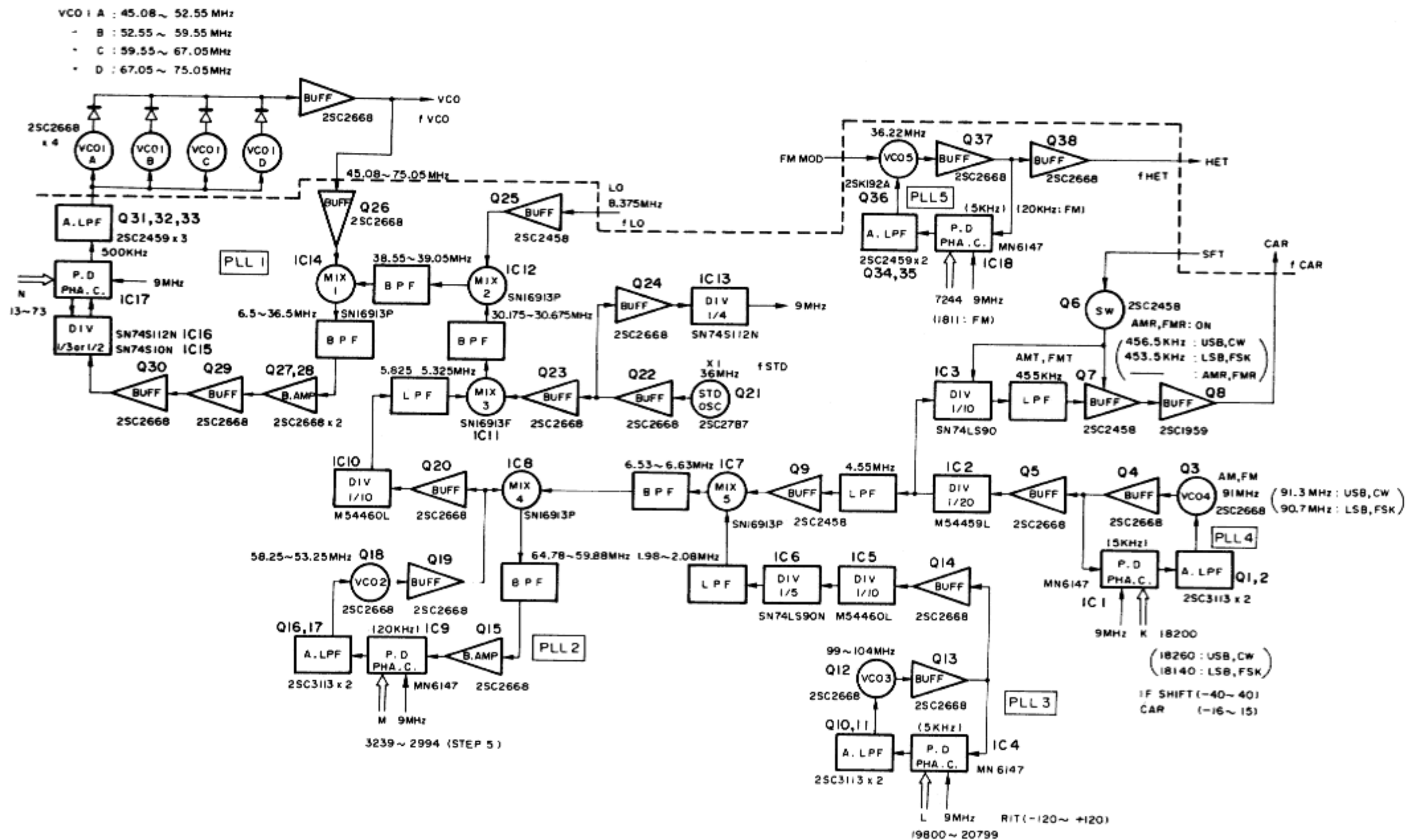

Fig. 12 PLL circuit block diagram

• PLL4

PLL4 consists of IC 1 (MN6147) and its associated loop circuit. VCO4, Q3 (2SC2668), is locked at a frequency of approximately 91 MHz, which differs depending on the operational mode. The 9 MHz reference frequency is applied to pin 3 of IC1, where the signal is divided by 1800 to generate the 5 kHz signal for frequency comparison. The output of VCO4 is supplied to IC1 pin 16 via buffer amplifier Q4 (2SC2668). In IC1, the output is divided by an appropriate division ratio (18200 or so) which differs depending on the mode. The phase of the signal is compared with that of the 5 kHz reference signal by the phase comparator and the VCO4 oscillation frequency is locked. Frequency division data is sent from the digital unit (DA0 to DA3 and CK3).

The output from PLL4 goes through buffer amplifier Q5 (2SC2668) and is divided by 20 in IC2 (M54459L). The signal is further divided by ten in the carrier circuit of IC3 (SN74LS90N) and then fed into the IF unit as the carrier signal via the LPF, and buffer Q7 (2SC2458) and Q8 (2SC1959). In AM or FM receive mode, switching circuit Q6 (2SC2458) operates when an SFT signal is sent, and as a result, IC3, Q7, and Q8 are stopped to cut carrier signals.

The PLL4 output signal also goes through the LPF and buffer amplifier Q9 (2SC2458) and is fed into the mixer in the main loop, where the signal is used to form the digital VFO signal. As a result, the operating frequency does not change even if the carrier frequency is changed, which

ensures a stable carrier point adjustment. In SSB, CW, or FSK reception mode, the carrier may be shifted ± 1 kHz or more and the carrier point can be adjusted in the range from -400 Hz to $+350$ Hz.

• PLL3

PLL3 consists of IC4 (MN6147) and its associated loop components. VCO3, Q12 (2SC2668), is locked in the range of 99 MHz to 103.995 MHz. The 9 MHz reference frequency signal is supplied to pin 3 of IC4, where the signal is divided by 1800 to generate the 5 kHz signal for frequency comparison. The output of VCO3 goes through buffer amplifier Q13 (2SC2668) and is applied to IC4 pin 16. In IC4, the output is divided by L and the phase of the signal is compared with that of the 5 kHz reference signal by the frequency comparator, and VCO3 oscillation frequency is locked (in 5 kHz steps). The division ratio, L, is supplied by the microprocessor, in the digital unit, (DA0 to DA3 and CK2). L is in 1000 steps (19800 to 20799) corresponding to 0.00 kHz to 9.99 kHz. In CW receive, in order to obtain 800 Hz beat signals in the operation frequency display, the L is shifted -80 (19720 to 20719) and when RIT/XIT operates, the L is changed so that f_{VCO} is shifted ± 1.2 kHz or more. In AM or FM mode, the L is shifted by 10 steps to change f_{VCO} by 100 Hz steps.

Output from PLL 3 goes through buffer amplifier Q14 (2SC2668) and is fed into the mixer in the main loop, where the signal is used to form the digital VFO signal. As a result, the operating frequency does not change even if the carrier frequency is changed, which

CIRCUIT DESCRIPTION

into pin 2 of MIX5 IC7 (SN16913P) via the LPF. In MIX5, the signal is mixed with the signal generated by PLL4 and goes through the BPF to generate a signal in the range of 6.53 MHz to 6.6301 MHz (in 100 Hz steps). The generated signal is supplied to pin 5.

• PLL2

PLL2 consists of IC9 (MN6147) and its loop circuitry. VCO2, Q18 (2SC2668), is locked in the range of 58.25 MHz to 53.2501 MHz. The 9 MHz reference frequency signal is supplied to pin 3 of IC9, where the signal is divided by 450 to generate a 20 kHz signal for frequency comparison. VCO2's output goes through buffer amplifier Q19 (2SC2668), and is fed into MIX4 pin 2 and mixed with the 6.35 MHz to 6.63 MHz signals applied to pin 5. The mixed signal then goes through the BPF to obtain 64.78 MHz to 59.88 MHz signal (in 100 kHz steps). The 64.78 MHz to 59.88 MHz signal is fed into IC9 pin 16 via buffer amplifier Q15 (2SC2668). In IC9, the signal is divided by M, and the phase of signal is compared with that of the 20 kHz reference signal by the phase comparator, and thus MIX4 output is locked (in 100 kHz step). The division ratio M is supplied from the digital unit (DA0 to DA3 and CK1), and is in 50 steps from 3239 to 2994 corresponding to 0.00 MHz to 0.49 MHz.

The output from PLL2 goes through buffer amplifier Q20 (2SC2668) and is divided by ten in IC10 (M54460L). Via the LPF, the signal is fed into pin 2 of MIX3 IC11 (SN16913P). The frequency of the signals depends on the values of L and M, and is in the range of 5.825 MHz to 5.32501 MHz (10 Hz step).

VR1 in MIX4 circuit is used to suppress spurious outputs from the mixer. It is necessary to prevent PLL2 from becoming unlocked.

Signals generated by PLL2 and the 9 MHz reference frequency are mixed in MIX3. The mixed signal goes through the BPF, and is further mixed with f_{L0} in MIX2 IC12 (SN16913P) on the IF unit. The output from MIX2 goes through the BPF to obtain 38.55 MHz to 39.04999 MHz. The signals are then mixed with the output from the final VCO oscillator in MIX1.

• PLL1

The last PLL loop, PLL1, consists of IC17 (MB87006) and its loop components. In IC17, frequency division for reference and comparison frequencies is set by serial data (SO, SCK, and LE). When an external prescaler is used, IC17 has a modulus control function for configuring the pulse swallow counter.

The VCO oscillator output from the RF unit goes through Q26 (2SC2668) in the PLL unit and is fed into MIX1. The mixed signals go through the BPF, and they are then amplified by buffer amplifiers Q27 thru Q30 (2SC2668), shaped by IC15 (SN74S10N1/3), and fed into IC16 (WN74S112N) 1/3, or 1/2 prescaler. Basically, IC16 is a two-level FF circuit and functions as a 1/4 divider. But, when IC17 of the PLL unit sends control signals, to IC16, IC16 functions as a 1/3 or 1/2 frequency divider in con-

The 9 MHz reference frequency signal is supplied to pin 1 of IC17, where the signals are divided by 18 to generate a 500 kHz signal for frequency comparison. Signals fed into IC17 pin 8 via MIX1 and the buffer amplifier are divided by N, and the phase is compared with that of the 500 kHz reference signals by the phase comparator. The signal then goes through the active LPFs Q31 to Q33 (2SC2459) and is fed into the RF unit as VCO voltage signals to control the variable capacitor of the final VCO. The frequency divider N covers the full range of operating frequencies from 30 kHz to 30 MHz (500 kHz step), and it has 61 steps of frequency division data supplied by the microprocessor in the digital unit.

The last VCO signal in PLL1 therefore depends on the values of L, M, and N, and it is in the range from 45.08 MHz to 75.05 MHz (10 Hz step). N is expressed as follows:

$$N = PN_0 - A \\ (N_0 > A)$$

P: Prescaler module value

No: Programmable counter value

A: Swallow counter value

PLL IC contains N_0 and A.

The last VCO unit is contained in the RF unit and consists of four VCOs, each handling one portion of frequencies from 30 kHz to 30 MHz. The appropriate VCO is selected by the microprocessor according to band information from the digital unit.

• Unlock

If a PLL loop enters a unlock state, the output on the UL pin becomes L. This L signal is sent to the digital unit to stop the microprocessor.

• 500 kHz marker signal

The 500 kHz reference signal for frequency comparison is supplied from IC17 pin 13, and it is used as the marker reference signal.

5. Digital control circuit

The TS-440 digital control circuit uses an 8-bit CPU (7800) which does not contain ROM, and has a 16K ROM (27128) and a 2K RAM (8418) outside the CPU. A common bus used for data exchange between the CPU and RAM, and between the CPU and ROM and is also connected in parallel to the two 8255's for extended I/O and an 8251 for interface to a personal computer (option). To transfer data to or from an appropriate IC, the CPU uses the WR or RD signal, and the chip select signal from the 74LS138.

The display is dynamically controlled by software, and consists of 13 digits and nine segments. The 13 digit and seven segment signal is driven by the high voltage resistive buffer (6300), and the other two segment signals are driven by a transistor. The 7800 transfers data serially. The clock signal

CIRCUIT DESCRIPTION

pulses and U/D signals from two clock signals which are 90° out of phase with each other, and sends the pulses and signals to the 7800. A clock pulse interrupts the 7800 and a U/D signal causes the 7800 to perform a count up or down operation for each step. If fast rotation occurs, the 7800 processes several steps of PLL data at one time.

Voltages from the RIT and IF shift VRs are converted from analog to digital by the A/D converter IC (4052) and fed into the 7800. The voltages are used to drive the display and are reflected in the PLL data.

The digital control circuit contains two 8255's for extended I/O. The 8255 in control unit A is an output only element and the 8255 in control unit B is an input only element for key scan and static data. The output 8255 emits VS-1 signals,

PLL data for the 6147, clock signals, and 1 MHz LED data. The input 8255 receives key scan data such as panel switch data and DIP switch data for CAR compensation. It also receives static data which cannot be entered as a portion key scan data.

The 7800 outputs four bits of band and mode information (11 bands in the frequency range from 30 kHz to 30 MHz). Each time the 8251, used as the interface to a personal computer, receives one byte of data, the 7800 is interrupted and reads the data from the 8251. The 7800 analyzes any command in the data. In response to the command, the 7800 controls setting or writes data to the 8251 as required. The 8251 serially sends one byte of data including a start bit, synchronizing to a 4800 Hz clock signal.

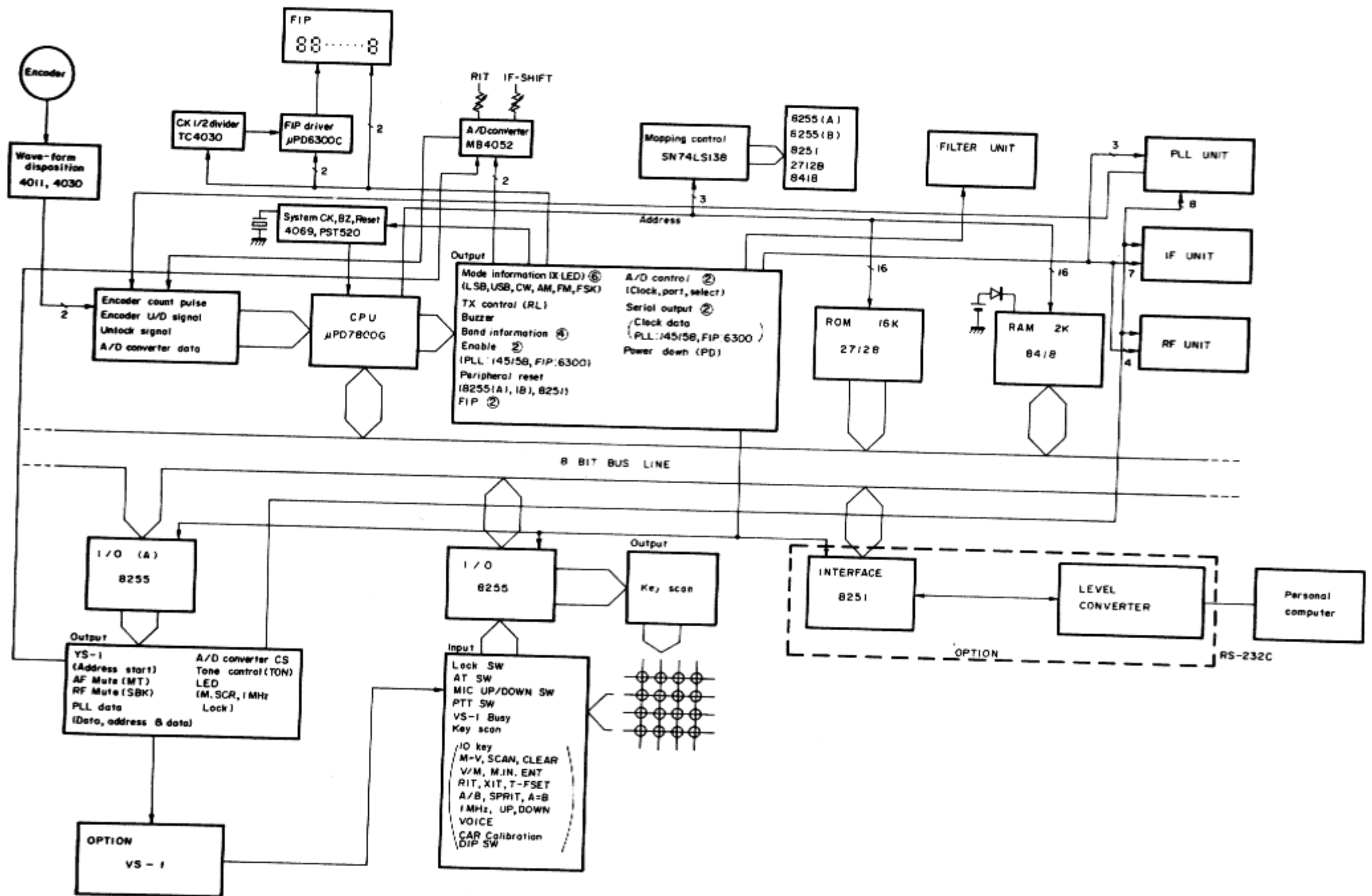

Fig. 13 Control circuit block diagram

CIRCUIT DESCRIPTION

1. Encoder

The TS-440S uses an optical encoder. Two different clock signals from the encoder are 90°, out of phase with each other. This phase difference is not adjustable but depends on the precision of the module. The two clock signals are

converted into clock pulses (250 pulses/rotation × 4) and U/D signals indicating the direction of rotation by the 4011 and 4030 and fed into the 7800. Figure 15 is a timing chart for clock pulse and the U/D signal transmitted to the 7800.

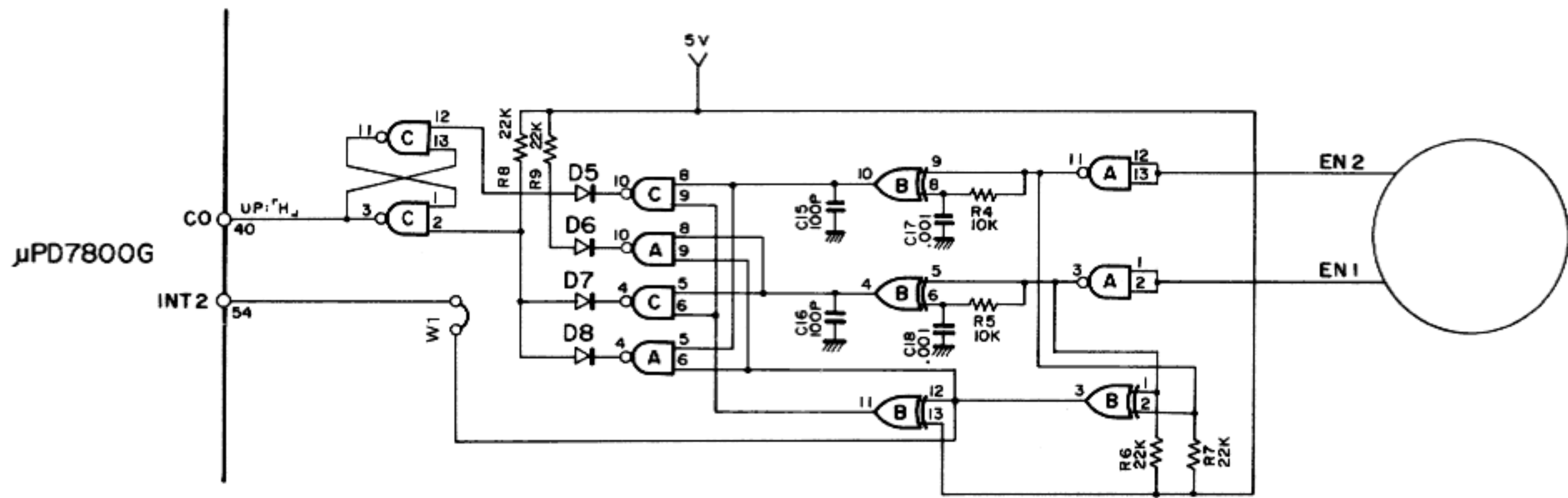

Fig. 14 Encoder circuit

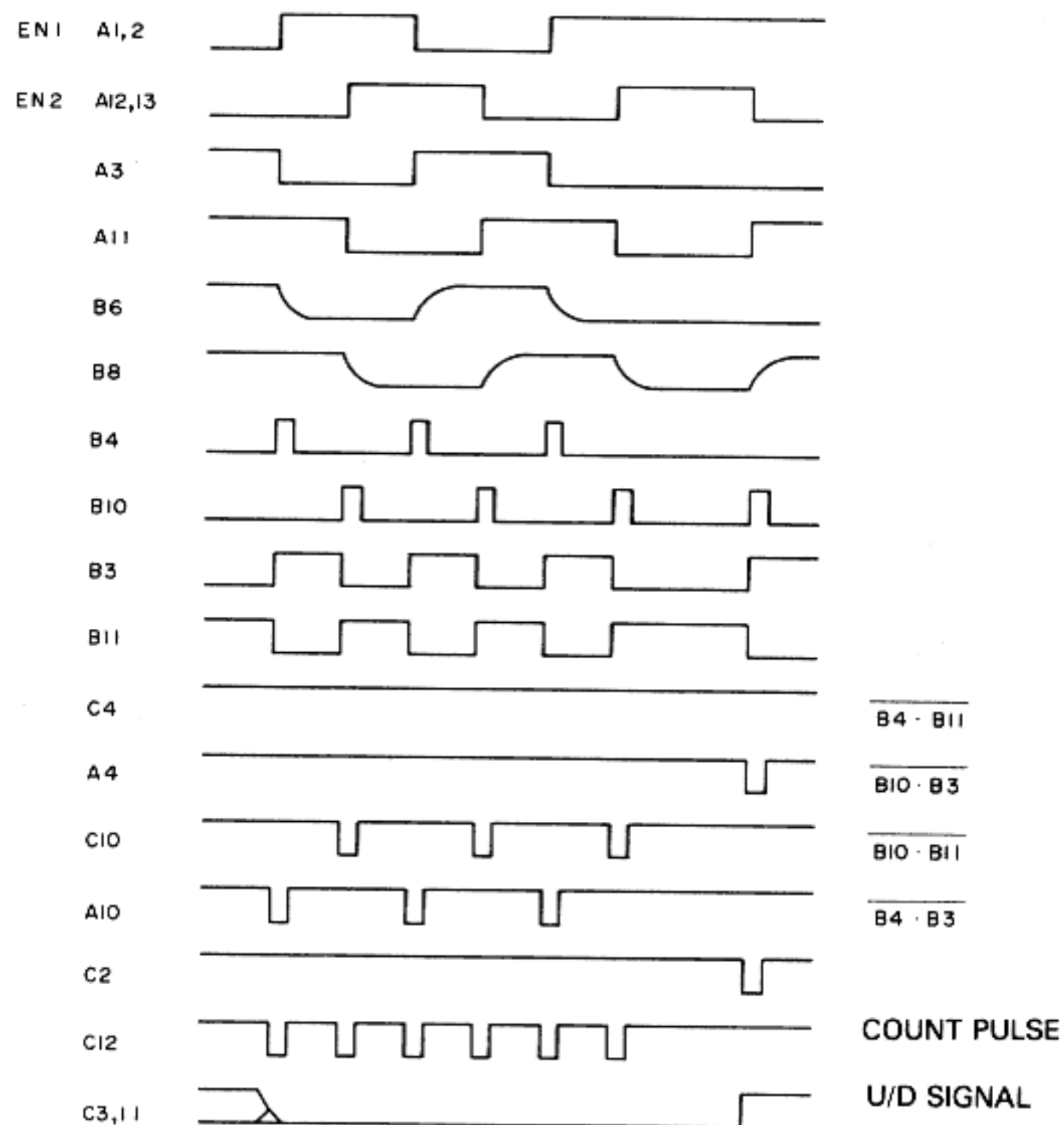

Fig. 15 Encoder waveform timing chart

CIRCUIT DESCRIPTION

2. Digital display

FIP digit and segment signals are driven by the 6300 but decimal point and red character signals are driven by a transistor. 8 V is used to increase the brightness of red characters. The 7800 sends display data serially at 1 MHz, but the clock signals are divided by two (500 kHz) in the 4080 and fed into the 6300. Figure 16 shows how the frequency division is accomplished. The 7800 sends data from its SO pin

(pin 28) and a clock signal from its SCK pin (pin 26) at approx. 1 ms intervals. After the 7800 has sent 8 bits of data five times, the 7800 sends a negative enable pulse from port B5 (pin 46). When a decimal digit goes on, the 7800 sets port C4 to L and when a red character goes on the 7800 sets port C3 to H.

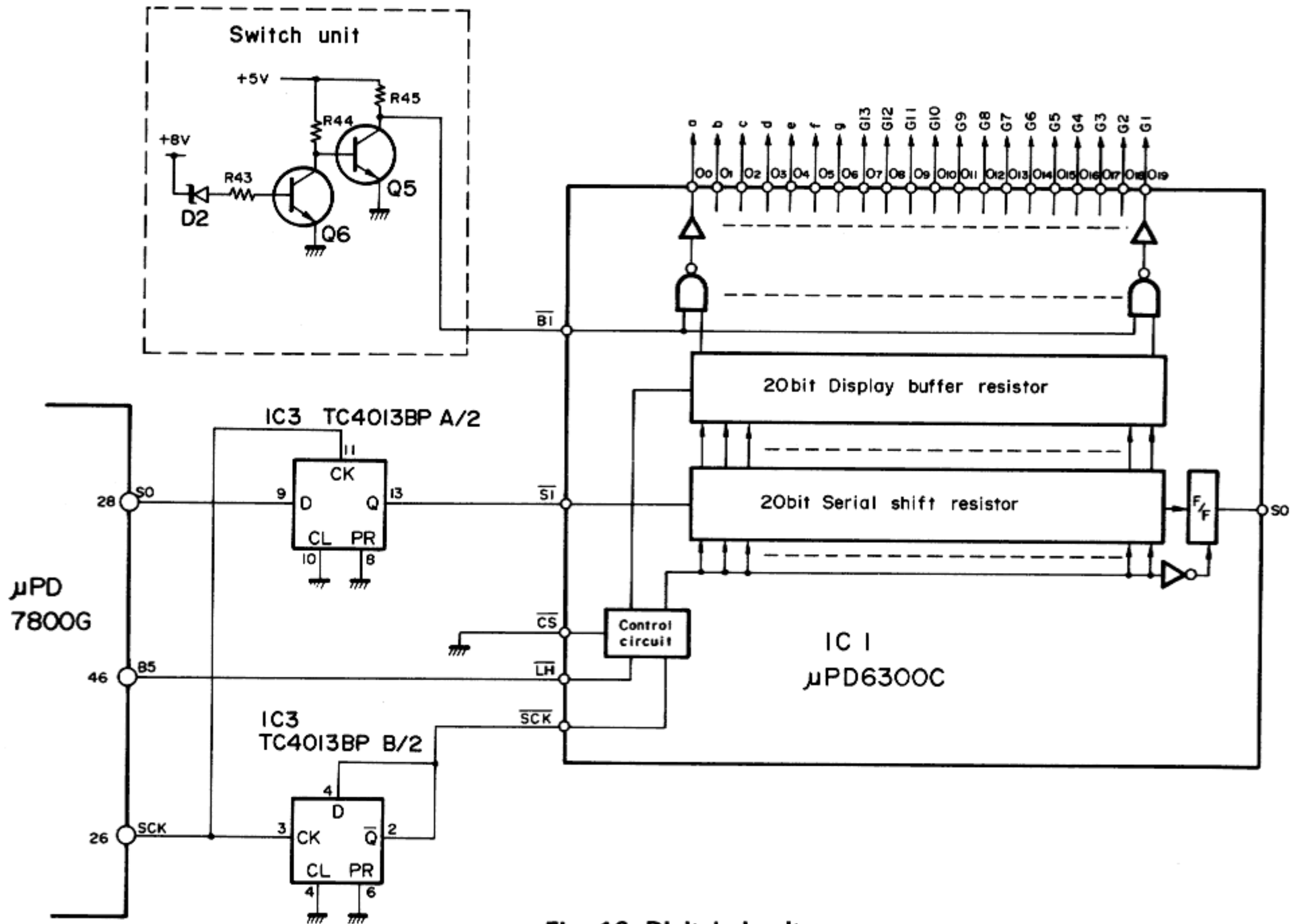

Fig. 16 Digital circuit

3. Key scan input

The key scan input block sends key scan signals (negative pulses) from its 8255 (IC53) port C in the order of C0 to C7 (C6 and C7 are output only once when the POWER switch is turned on). When a matrix crossing point switch is on, its

corresponding bit in the 8255 port A is L to enable the switch to be identified. Figure 13 shows the matrix. Key scan S6 and S7 are provided for the extended function using diodes.

Key scan matrix		S											
		1		2		3		4		5		6	
K	1	1	LSB	2	USB	3	CW	4	AM	5	FM		
	2	6		7		8		9		0	FSK		
	3	V/M		M·V		SCAN		M·IN		CLEAR		ENT	
	4			RIT		ZIT		T-FSET		1MHz		DOWN	
	5			A/B		SPRIT		A = B		25L	1	U.P	
	6	VOICE		T.SET ON		CLOCK 1		100L	3	50L	2	100U	8
	7	T.SET OFF						200L	4	25U	6	200U	9
	8	TIMER		SET		CLOCK 2		400L	5	50I	7	400U	10

CIRCUIT DESCRIPTION

4. Static input

7800 (IC1)		
C0	Encoder U/D signal	"H" when UP
C2	Unlock signal	"L" when unlock
07	4052 (IC: Display)	A/D convertor data
8255 (IC53)		
B0	Lock switch	"L" when switch on
B2	AT switch	"L" when switch on
B3	MIC UP switch	"L" when switch on
B4	MIC DOWN switch	"L" when switch on
B5	PTT switch	"L" when switch on
B7	VS-1 busy signal	"H" when VS-1 busy

Table 11.

5. A/D convertor input

Voltages controlled by the RIT and IF shift VRs are applied to the 4052 (IC2: Display). The 4052 has four analog inputs: A0 (IC2 pin 4) is connected to the IF shift VR, and A1 (pin 5) is connected to the RIT VR, the other two inputs are not used. When reading IF shift data, the 7800 sets port C5 to 0 and selects 4052 A0. As a result, the 3255 sends a positive pulse from port B0 to reset the 4052, and the 7800 sends nine positive pulses from port C6, and port C7 receives data. When reading RIT data, the 7800 sets C0 from the 4052 to H and thereafter performs the same operations as when reading IF shift data.

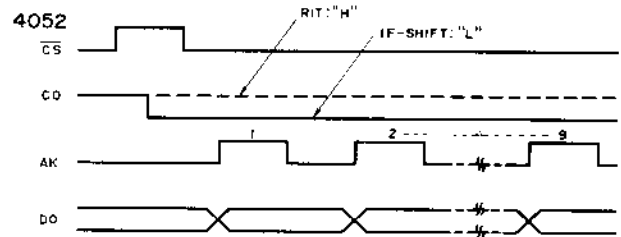
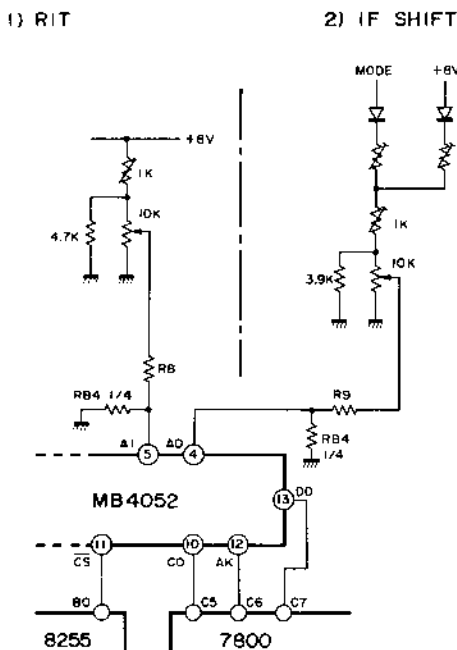

A/D converter Input
Fig. 17 A/D converter circuit

6. AT control

When the AT switch is turned on with the AUTO/THRU switch in the AUTO position, 8255 (IC53) ports B2 and B5 go on. When the 7800 knows that the AT switch is on via port B2, it will enter the CW-mode, and sets port A2 to H and A0, A1, and A3 to A6, and B4 to L, and transfer a power down signal. The 7800 then knows that the PTT switch is on via 8255 port B5, and sets port A6 (transmission control signal) to H, enabling transmission. However, if the selected frequency does not allow the 7800 to prepare for transmission, 7800 port A6 remains L and the 7800 will not enable transmission. When the selected frequency is 1.9 MHz or less, the 7800 will not enter CW mode nor send a power down signal.

7. LED output

Depending on the mode, the 7800 makes the 8255 (IC2) send M, SCR, 1 MHz, and lock LED signals from ports B4, B5, and B6. When the LED goes on, these ports are L. When the mode LED is on, 7800 ports A0 to A5 are H. A0 to A5 correspond to LSB, USB, CW AM, FM, and FSK respectively. Mode LED output is used as mode control signals in the IF unit.

8. VS-1 (option)

When the voice switch is turned on, an address corresponding to the instruction (numerical data) entered is sent from 8255 (IC2) ports A0 to A4 and a positive start pulse signal is sent from port A5. The VS-1 sends busy signals (H) to 8255 (IC53) port B7 while the voice switch is on. After the voice switch goes off, an address corresponding to the next instruction and a start signal are sent.

9. μPD 7800 reset circuit

The 7800 reset circuit is used to initialize the 7800 when the POWER switch is turned on. This circuit supplies a reset pulse to the 7800 after the clock is supplied to the 7800 system clock input, X1 (pin 31). Since IC3 remains on until PST520D (IC3) pin 1 reaches 4.3 V, C10 is not charged, enabling a reset signal to be supplied. When pin 1 exceeds 4.3 V, IC3 goes off, causing C10 to charge via R2 and R3 and the reset signal is removed.

CIRCUIT DESCRIPTION

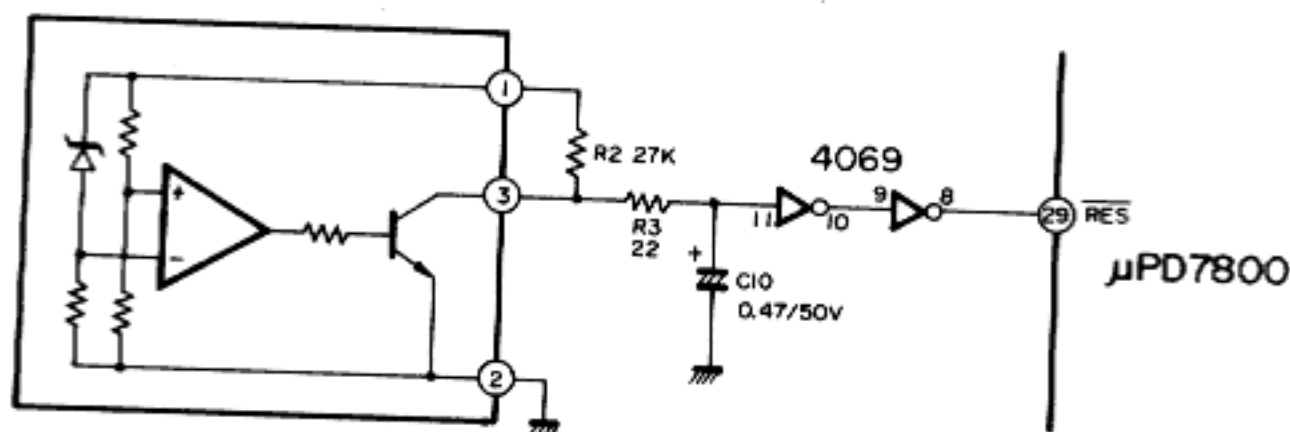

Fig. 18 Reset circuit

10. PLL output block

The PLL output block controls five PLL loops. The 500 kHz step PLL loop uses an MB87006 and the other PLL loops use MN6147s.

The M387006 has two dividers: one for the PLL reference frequency and the other for a swallow type counter. Frequency division data for the reference frequency is sent only one when the TS-440 power is switched on.

The MN6147 uses the PLL data format shown figure 19.

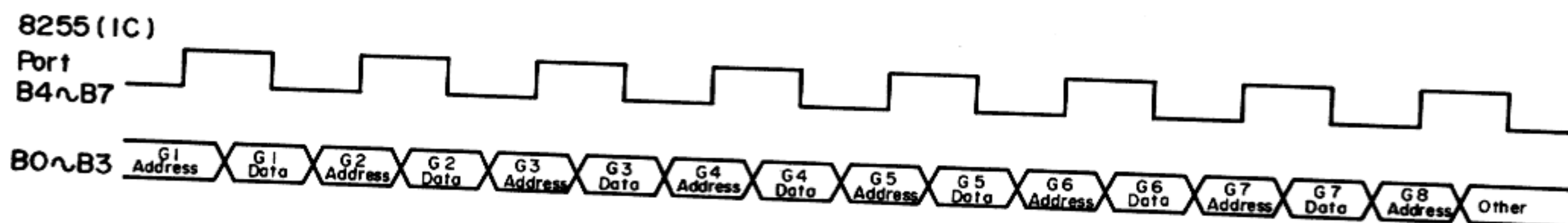

Fig. 19 MN6147 PLL data

Since the MN6147 has latches as shown in Figure 20, only data following a change is output. G0 data can be any data since it is used to transfer G2 and G7 data to the G8 latch.

11. Other outputs

RL output (7800 port A6)

This output signal controls transmission. When transmitting, this signal is "H".

BZ (Buzzer) output (7800 port A7)

This output signal makes the BZ circuit active. When this signal is "H", the oscillator circuit operates.

RESET output (7800 port B7)

This output signal resets the two 8255s and 8251 (option).

SBK output (8255 (IC2) port A6)

This output signal switches the RF unit to prevent noise due to PLL switching.

MT output (8255 (IC2) port A7)

This output signal controls the AF output to prevent noise due to PLL switching.

SCH output (8255 (IC2) port C0)

This signal controls the sub audible tone encoder. The sub-tone is activated whenever a transmit frequency in M-CH 90-99 has been selected, in the FM mode. A logic H activates the encoder.

12. CAR compensation DIP switch

This switch is used to compensate the absolute frequency characteristic of the 455 kHz filter. The characteristic can be compensated within the range of -400 Hz to +375 Hz. LSB and USB can be compensated separately. When LSB is compensated, FSK is also compensated.

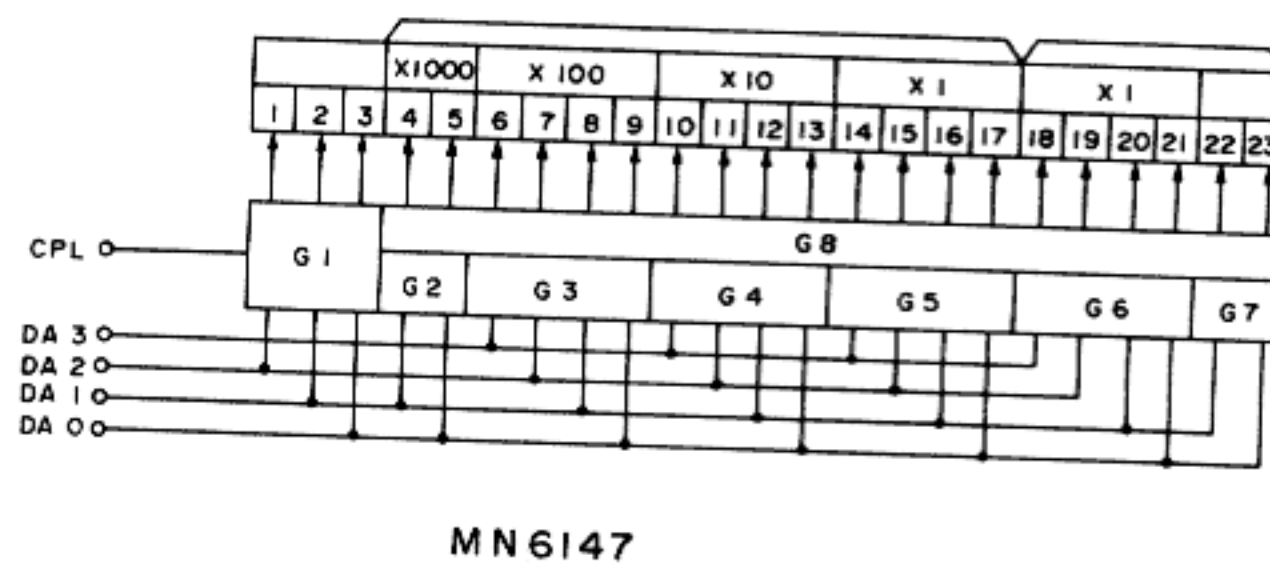

Fig. 20 Data input terminal and programmable counter

SW No.	Hz	
1	25	LSB
2	50	
3	100	
4	200	
5	400	
6	25	USB
7	50	
8	100	
9	200	
10	400	

Table 12

When all bits are off, -400 Hz is supplied for compensation. When no compensation is required, bits 5 and 10 must be set to 1.

CIRCUIT DESCRIPTION

13. Band information generation circuit (in the RF unit)

Band information from the control unit is sent to connector 15 of the RF unit. Band information signals B0 to B3 form a BCD code in which B0 corresponds to LSB. Q4D (M74LS145P) is used to convert data from BCD to DEC, and it generates control signals for ten of the 11 bands. Control signals for the remaining band (25.5 MHz to 30 MHz) are generated in the AND circuit consisting of D57, D58, and Q46. These control signals go through the current buffer consisting of Q41 to Q45 (M54561P and 2SA562Y), and are OR'ed by diodes, as required, and sent to AT unit, filter unit, CO, and ANT BPF, as shown in Figure 21.

Band information 7800 PB₀ ~ 3, B₃B₂B₁B₀

30kHz ~ 0.5MHz	0000
0.5MHz ~ 1.6MHz	0001
1.6MHz ~ 2.5MHz	0010
2.5MHz ~ 4MHz	0011
4MHz ~ 6MHz	0100
6MHz ~ 7.5MHz	0101
7.5MHz ~ 10.5MHz	0110
10.5MHz ~ 14.5MHz	0111
14.5MHz ~ 22MHz	1000
22MHz ~ 25.5MHz	1001
25.5MHz ~ 30MHz	1010

Table 13

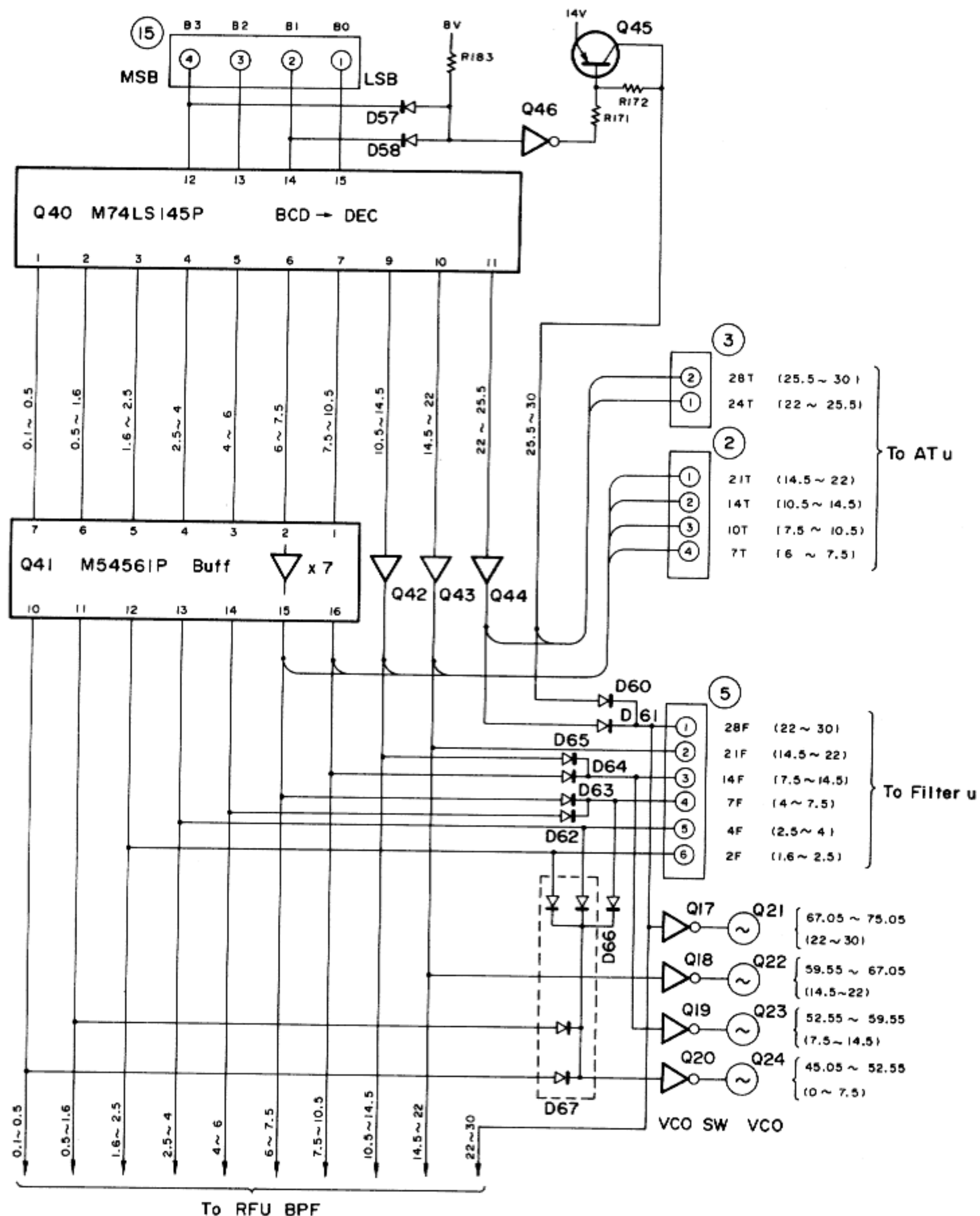

CIRCUIT DESCRIPTION

14. Mode control signals

Transmit/receive mode signals are generated by IC10 in the IF unit. IC10 is a hybrid IC containing five pairs of PNP transistors and diodes.

Figure 22 shows its equivalent circuit. When the mode signals SSB, CWB, RYB, AMB, and FMB are applied to pins 6

to 10, the voltages of control pins 16 and 17 change. During reception, these signals change to SSR, CWR, RYR, AMR, and FMR. During transmission, these signals change to SST, CWT, RYT, AMT, and FMT.

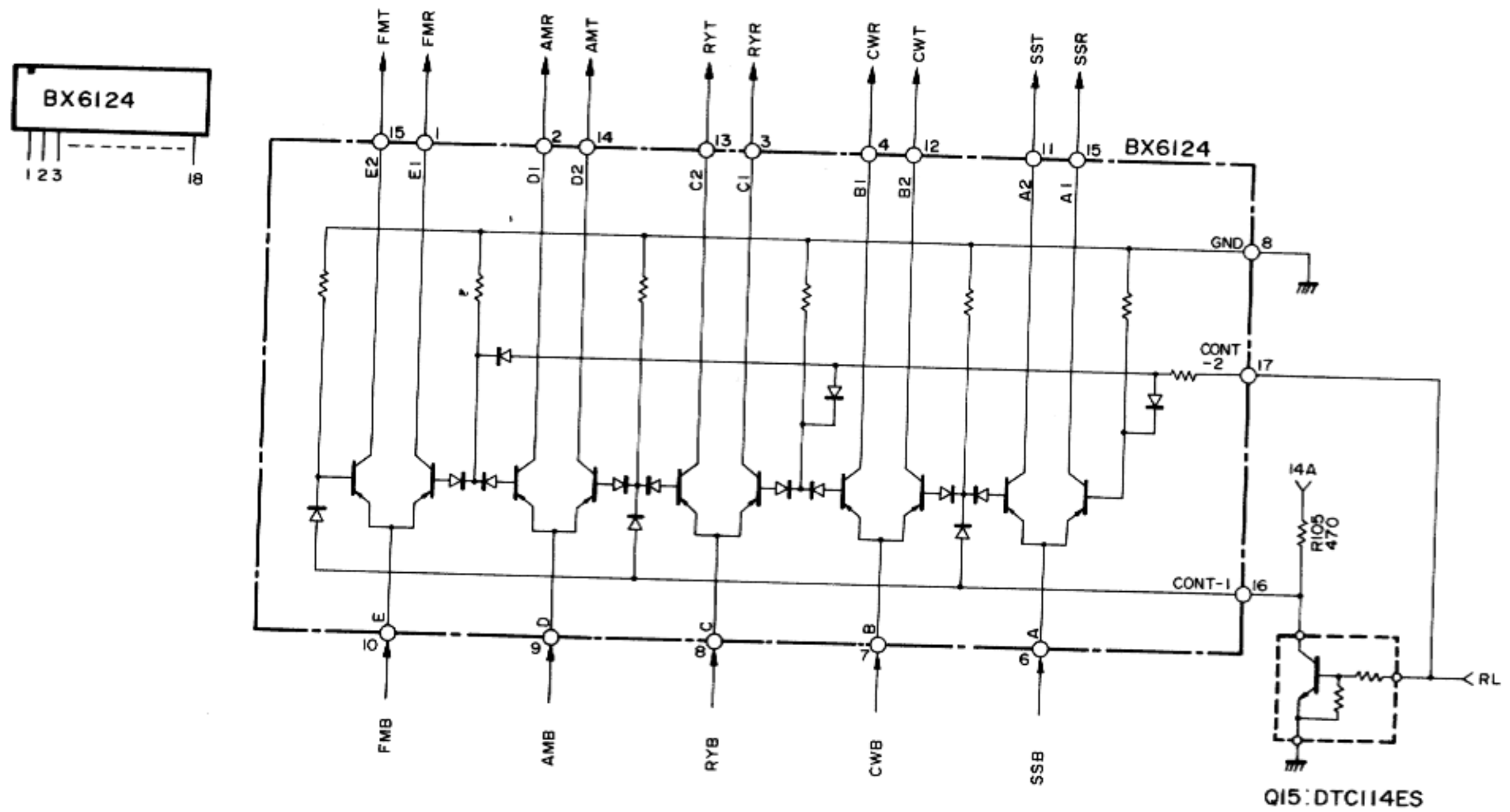

Fig. 22 Mode control circuit

15. Expand function

Control unit (X53-1450- 11)

D No.	Shipped		Diode cut
65	Mode beep tone	Morse	Single tone
66	10Hz display	OFF	ON
67	Memory protect	OFF	ON
73	CW shift	800Hz	400Hz
78	W 24 TX	No	Yes
79	W 18 TX	No	Yes

Table 14 Expand function

16. Semi-self test function

Semi-self test is started by turning the POWER switch on with the **4** (AM) and T-F SET switches pressed.

This test provides a method of testing the TS-440 digital system in a shorter time during production or servicing. The test enables the following:

1. Circuits which are difficult to test during program execution to be tested easily. For example, dynamic data can be output as static data.
2. Items on which information is held only by the CPU and is not available to the user to be tested.

- a. Approximately threshold level input
- b. Incorrect input due to input pin fault

Operation procedure

1. POWER SW OFF
2. The power switch on while pushing switch **4** (AM) and switch T-F SET
3. The test number has starts from "0" to "56" and END when turn the VFO knob clockwise. Operation chart shows as follow.
4. To reset SEMI-SELF TEST function, Power switch OFF.

TEST NO. LIST

TEST NO	Condition	TEST NO	Condition
0	Start All Fip's light's	31	RES = "H"
1	All Fip's light's (Segment)	32	.. = "L"
2	All Fip's light's	33	CO = "H" (A/D)
3	All Fip's OFF (digit)	34	.. = "L" (")
4	Each digit lights G1	35	AX = "H" (")
5	" G2	36	.. = "L" (")
6	" G3	37	8255 Port A all = "H" (IC2)
7	" G4	38	" " all = "L" (..)
8	" G5	39	8255 Port B all = "H" (..)
9	" G6	40	" " all = "L" (..)
10	" G7	41	8255 Port C C0 ~ C3 = "H" (..)
11	" G8	42	" " C0 ~ C3 = "L" (..)
12	" G9	43	8255 Port C all = "H" (IC53)
13	" G10	44	" " all = "L" (..)
14	" G11	45	LOCK,PTT,MIC,U/D,AT,VS-1(BUSY)check
15	" G12	46	[SIMPLEX] VS-1(BUSY)check
16	" G13	47	Key scan inport check
17	BZ ON	48	1 (LSB), 6 ,V/M,VOICE (check)
18	BZ OFF	49	2 (USB), 7 ,M/V,RIT,A/B (check)
19	Mode LED all ON	50	3 (CW), 8 ,SCAN,XIT,SPRIT (check)
20	" all OFF	51	4 (AM), 9 ,MIN,T-FSET,A = B,100L 200L 400L (") ③ , ④ , ⑤
21	RL = "H"	52	5 (FM), 0 ,(FSK),CLEAR,1MHz,25L 50L 25U 50U (") ① , ② , ⑥ , ⑦
22	" = "L"	53	ENT,DOWN,UP, 100U 200U 400U ⑧ , ⑨ , ⑩
23	BAND all = "H"	54	-
24	" all = "L"	55	-
25	PD = "H"	56	END
26	" = "L"		
27	ENF = "H"		
28	" = "L" (immediatly)		
29	ENP = "H"		
30	" = "L"		

TS-440S

SW Monitor

Display changes by TEST number

TEST NO	Display	/	/	/	/	/	/	/	0
45	LOCK			AT	MIC UP		MIC DOWN	PTT or AT	VS-1 BUSY
46									
47									
48	[1] LSB	[6]	V/M					VOICE	
49	[2] USB	[7]	M-V	RIT			A/B		
50	[3] CW	[8]	SCAN	XIT			SPRIT		
51	[4] AM	[9]	M.IN	T-FSET			A=B	100L ③	200L ④
52	[5] FM	[0]	CLEAR	1MHz			25L ①	50L ②	25U ⑥
53			ENT	DOWN			UP	100U ⑧	200U ⑨
									400L ⑤
									50U ⑦
									400U ⑩

If the display changes from "/ " to " 0 " by operate the key in chart then function working properly.

SEMICONDUCTOR

SN74LS138H (Control unit IC51)

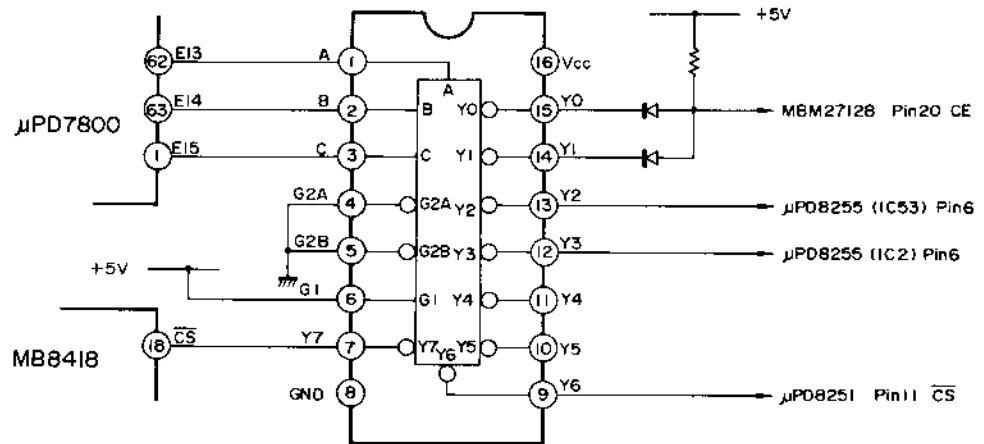
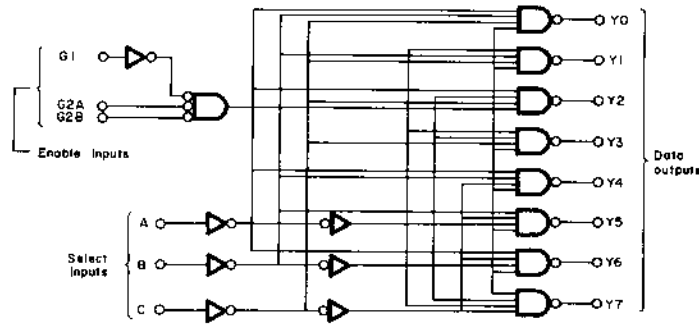

TRUTH TABLE

Input					Output							
Enable		Select			Y ₀	Y ₁	Y ₂	Y ₃	Y ₄	Y ₅	Y ₆	Y ₇
G ₁	G ₂	C	B	A								
x	H	x	x	x	H	H	H	H	H	H	H	H
L	x	x	x	x	H	H	H	H	H	H	H	H
H	L	L	L	L	L	H	H	H	H	H	H	H
H	L	L	L	H	H	L	H	H	H	H	H	H
H	L	L	H	L	H	H	L	H	H	H	H	H
H	L	L	H	H	H	H	H	L	H	H	H	H
H	L	H	L	L	H	H	H	H	L	H	H	H
H	L	H	L	H	H	H	H	H	H	L	H	H
H	L	H	H	L	H	H	H	H	H	H	L	H
H	L	H	H	H	H	H	H	H	H	H	H	L

Note: 1. $G_2 = G_{2A} + G_{2B}$
 2. H: High level
 L: Low level
 X: "H" or "L"

TC4013 (Display unit IC3)

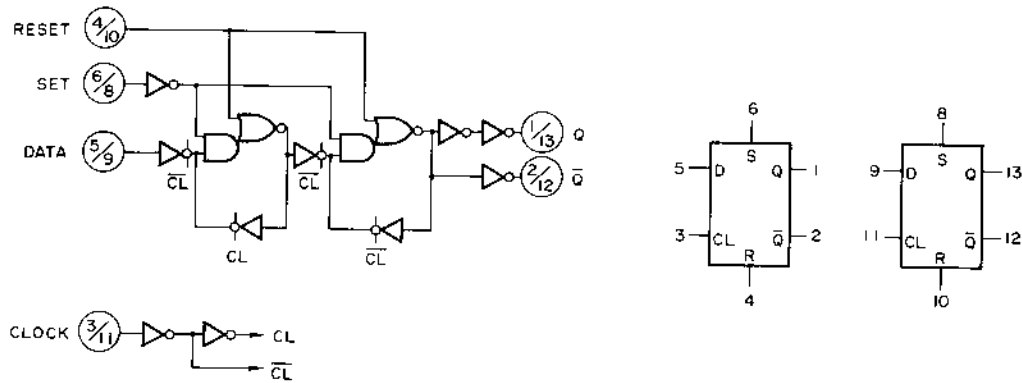

TC4040BP (Control unit IC55)

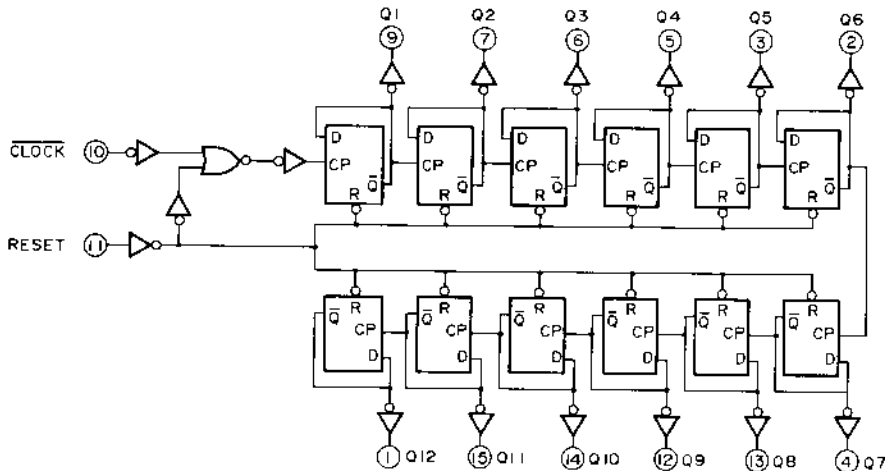

TC4069BP (Control unit IC4)

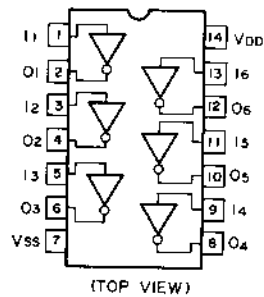

SEMICONDUCTOR

MB4052

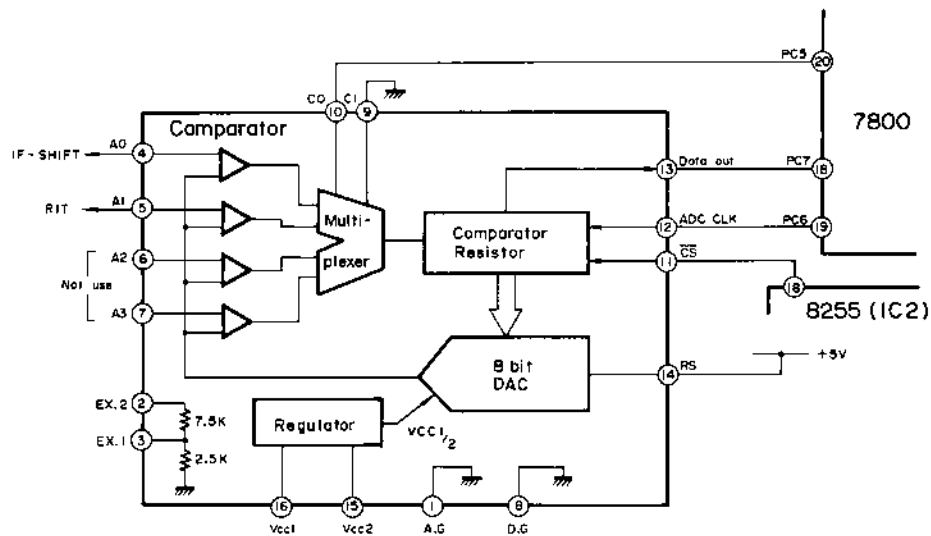

MB4052 Pin Description
I/O Signal Pin Functions

Pin No.	Pin Name	Symbol	Function
2	Range expander input	Ex. 2	Analog input pin for expanding the range.
3	Range expander output	Ex. 1	Analog output pin for expanding the range. Connect to any pin from A0 to A3. By using Ex. 1, Ex. 2, the range is expanded to the $\times 4$ range.
4 - 7	Analog entrance	A ₀ - A ₃	4 ch analog input pin. Channel 1 is selected by channel select input C0 to C1.
9	Channel select input	C ₀	The input pin to designate the analog input channel for A/D converter. This signal is latched at the trailing edge of CS.
10	Channel select input	C ₁	
11	Chip select input	CS	This is the chip select input pin. When CS is inverted from "1" to "0", A/D converting starts and data output is enabled. After A/D converting is over or when an interrupt is required, set the CS back to "1".
12	A/D conversion clock	ADC CLK	This is the clock input pin for A/D conversion input to the comparator register sequentially. Conversion speed is determined by the clock speed. In the case of 8-bit, approx. 10 clocks will be needed. However, it is not necessary that the clock period be fixed.
13	Data output	DATA OUT	This is the open collector to output the result of A/D conversion. The data is output in the order of the start bit, most significant bit, 2nd significant bit, ..., least significant bit, and the stop bit, synchronized with ADCCLK.
14	Range select input	RS	This is the input pin for selecting the voltage range of analog input. The $VFS = Vcc_1/8$ range is selected at "0", and the range of $FVS = Vcc_1/2$ is selected at "1". During conversion, hold this pin to "0" or "1".
1	Analog ground	A.G.	Ground terminal
8	Digital ground	D.G.	
15	Power supply pin 2	Vcc ₂	When driving with 3.5 to 6.0 V of power, connect Vcc ₁ and Vcc ₂ to each other, and apply the power voltage to them. When driving 8 to 18 V of power, apply the power voltage to Vcc ₂ . At this time, the 5 V stabilized voltage is output to Vcc ₁ , and approx. 10 mA current can be supplied externally to the IC. When either 3.5~6.0 V or 8~18V power is used, Vcc ₁ is the reference voltage for A/D conversion.
16	Power supply pin 1	Vcc ₁	

• Channel Select

C ₁	C ₀	Selected Ch.
0	0	A ₀
0	1	A ₁
1	0	A ₂
1	1	A ₃

• Range select

RS	Conversion voltage range
0	$0 \sim \frac{Vcc_1}{8}$
1	$0 \sim \frac{Vcc_1}{2}$

• Wiring example when expanding the range

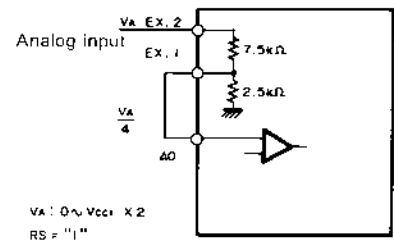

MB4052

MB8418-LP20-GRA (Control unit IC50)

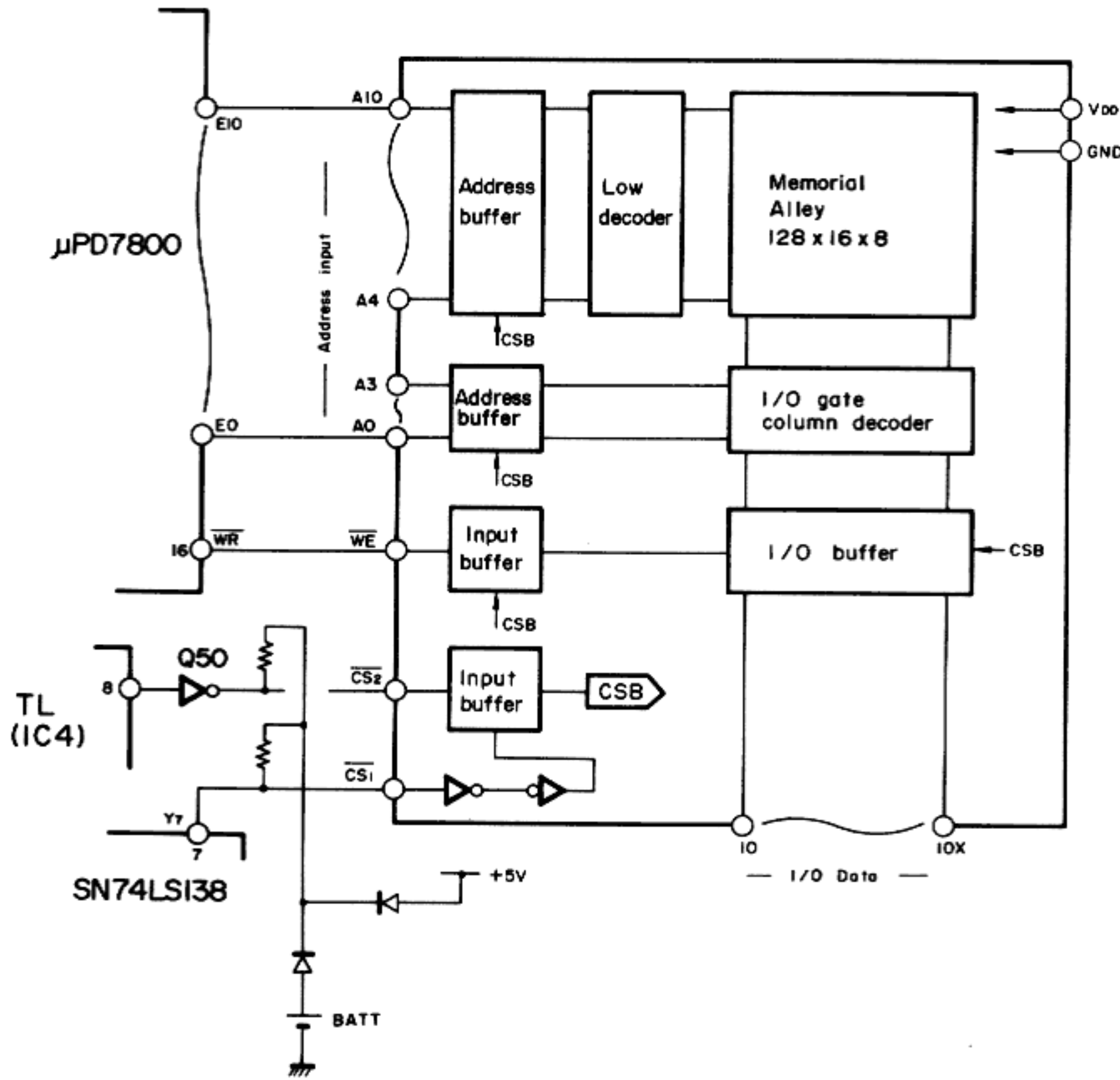

Symbol	Pin name
A ₀ ~ A ₁₀	Address input
I() ₁ ~ I() _X	Data in/out
\overline{CS}	Chip select 1
CS ₂	Chip select 2
\overline{WE}	Write enable
V _{cc}	Power (1.5 V)
GND	GND
NC.	No connection

MBM27128 (Control unit IC52)

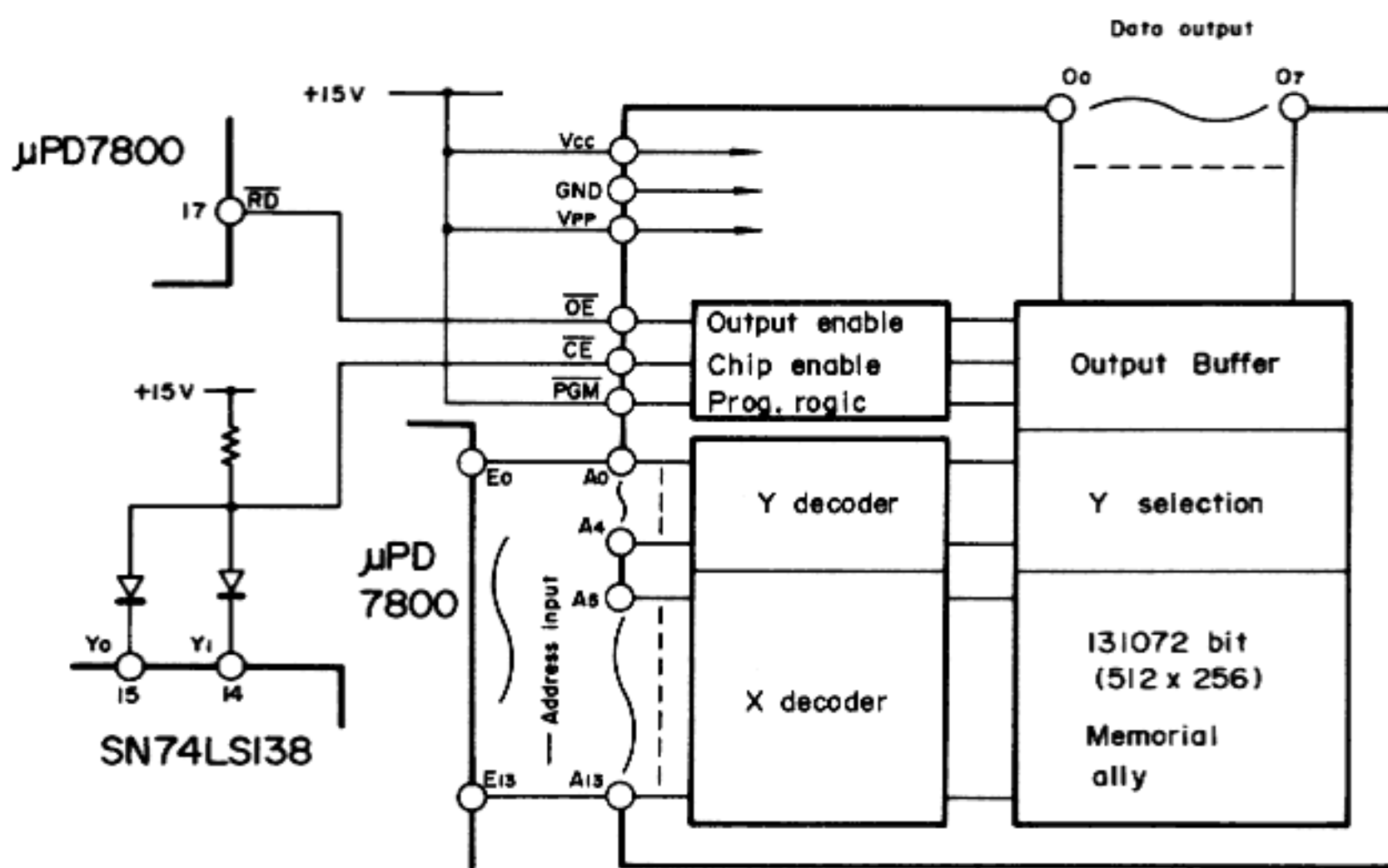

Pin name

A ₀ ~ A ₁₃	Address input
O ₀ ~ O ₇	Data output
\overline{CE}	Chip enable input
\overline{OE}	Output enable input
\overline{PGM}	Program input
V _{cc}	Power supply
V _{pp}	Program power supply
GND	GND

SEMICONDUCTOR

MC3347 (IF unit IC2)

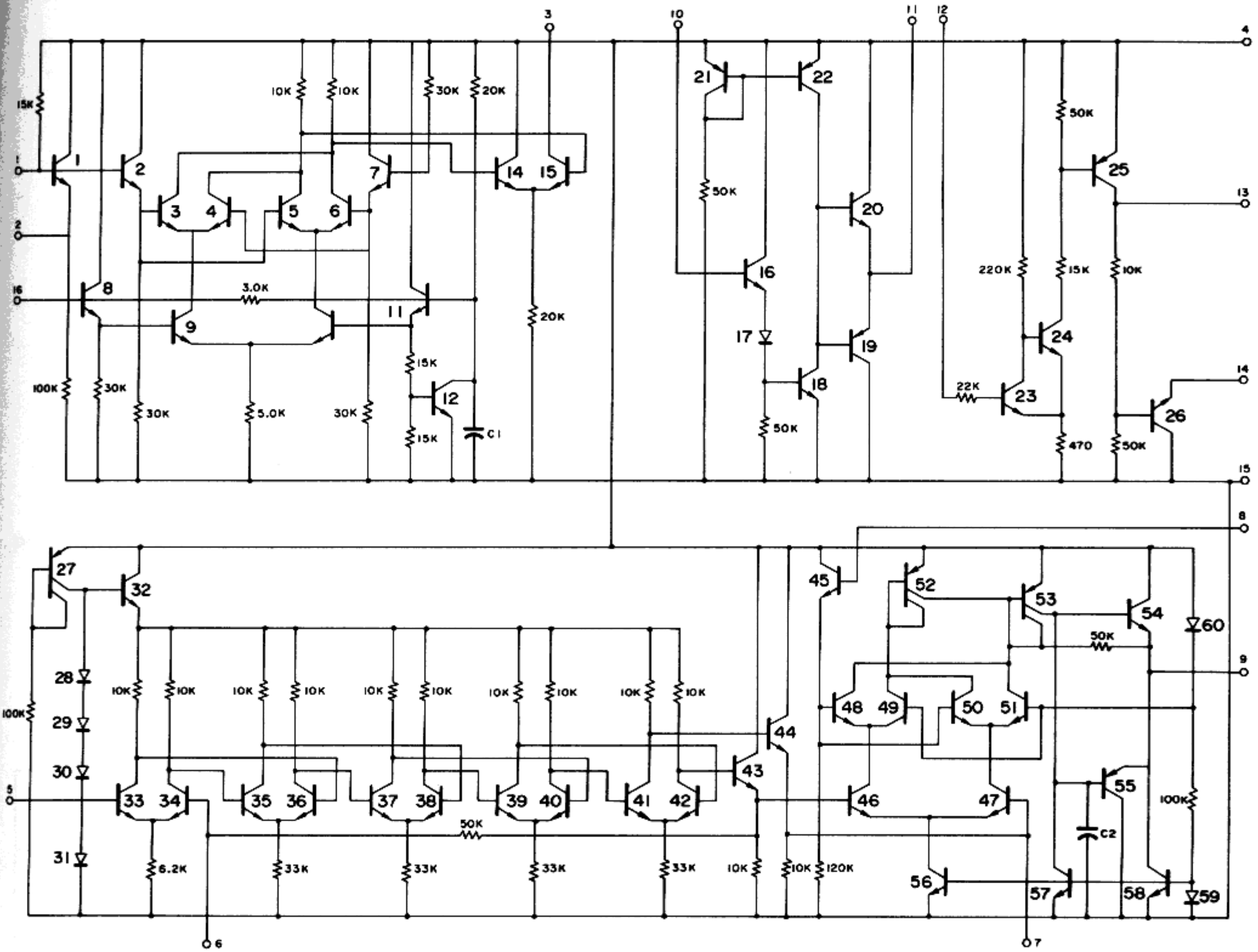

MC3357 (IF unit IC2)

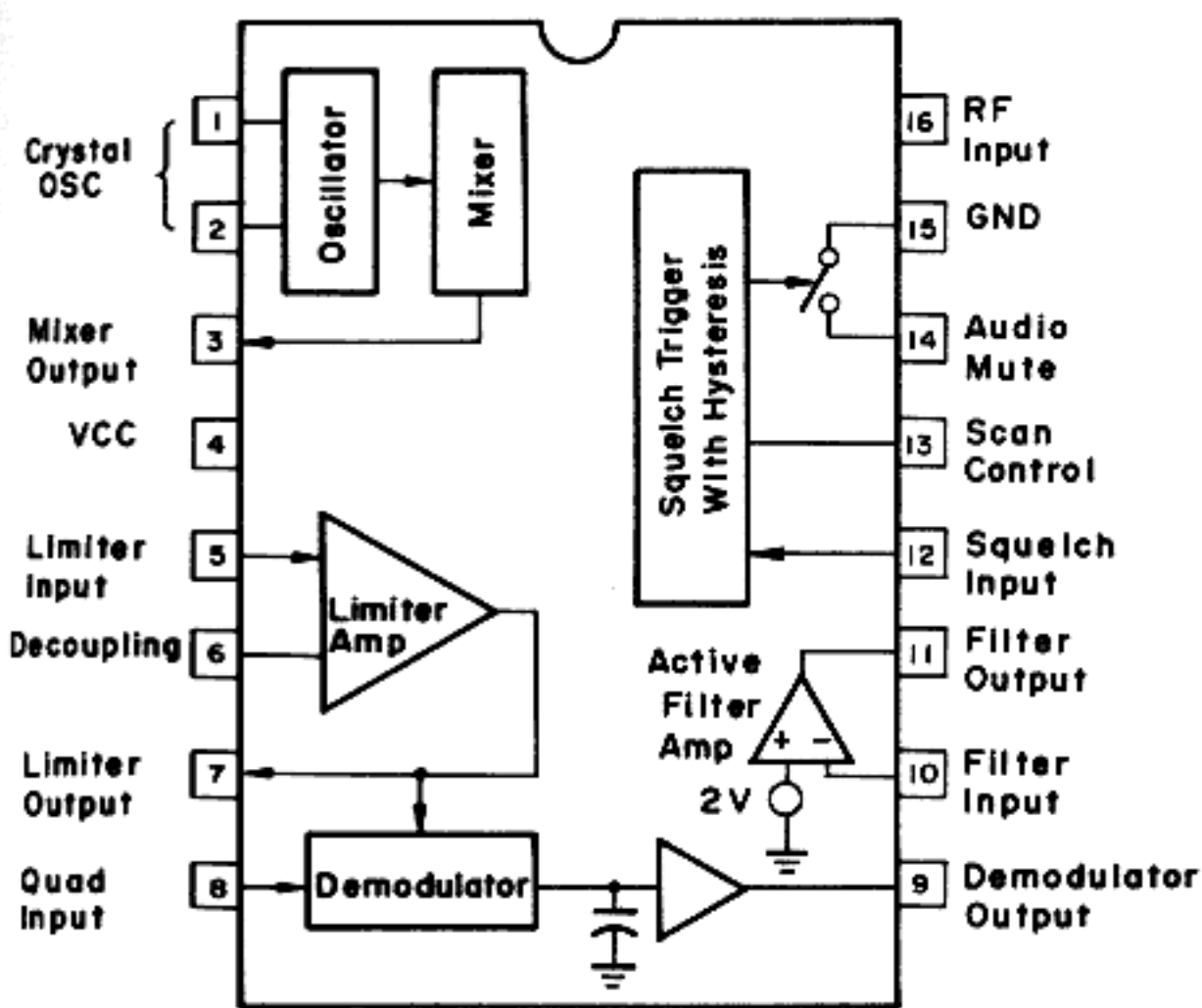

μPC1158H2

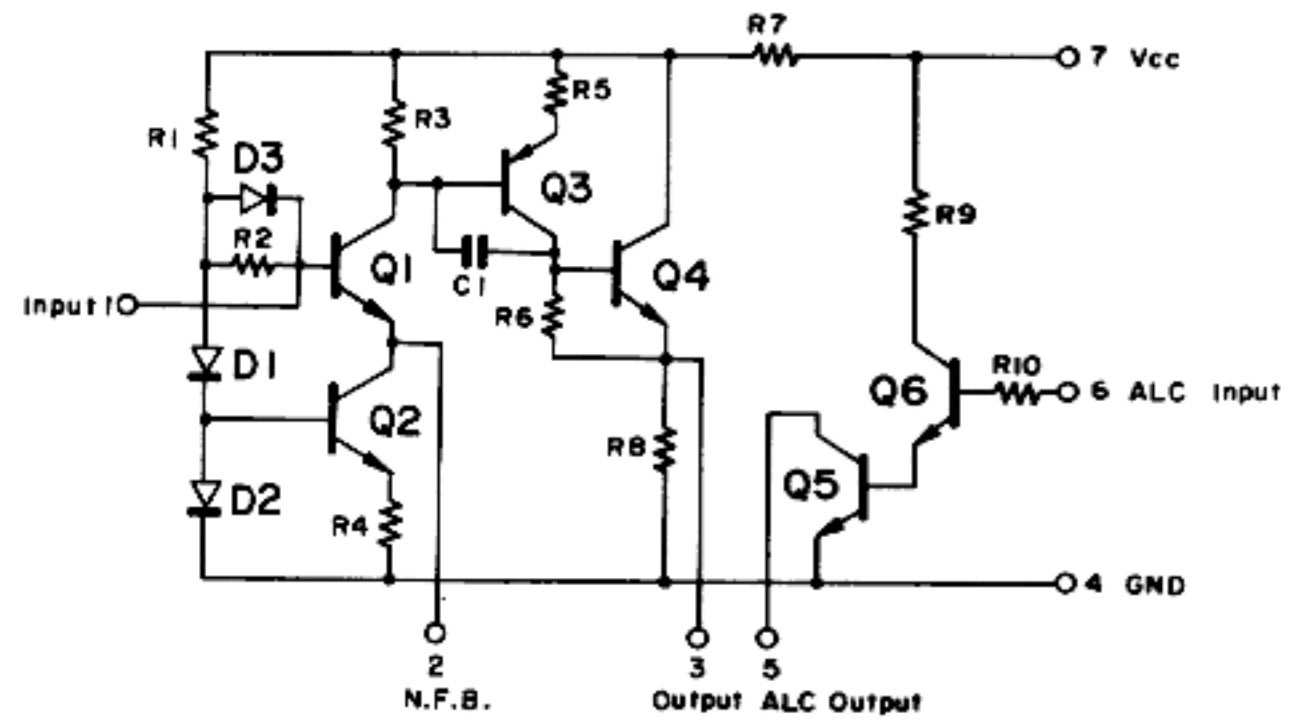
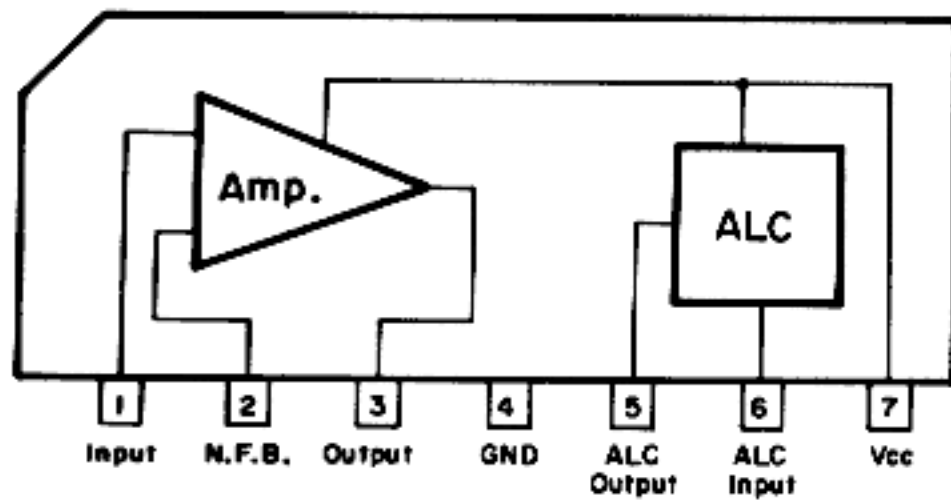

Pin connection

Pin	Function	Pin	Function
1	Input	5	ALC output
2	N. F. B.	6	ALC Input
3	Output	7	Vcc
4	GND		

μPC2002V (IF unit IC7)

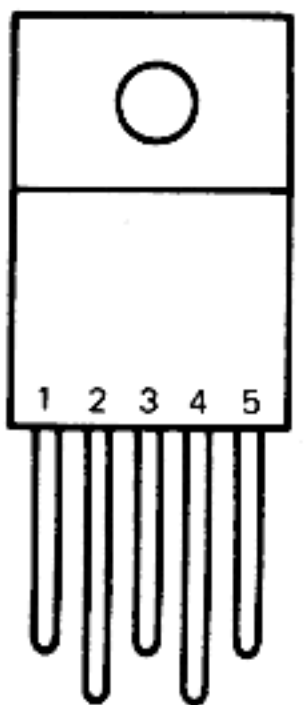
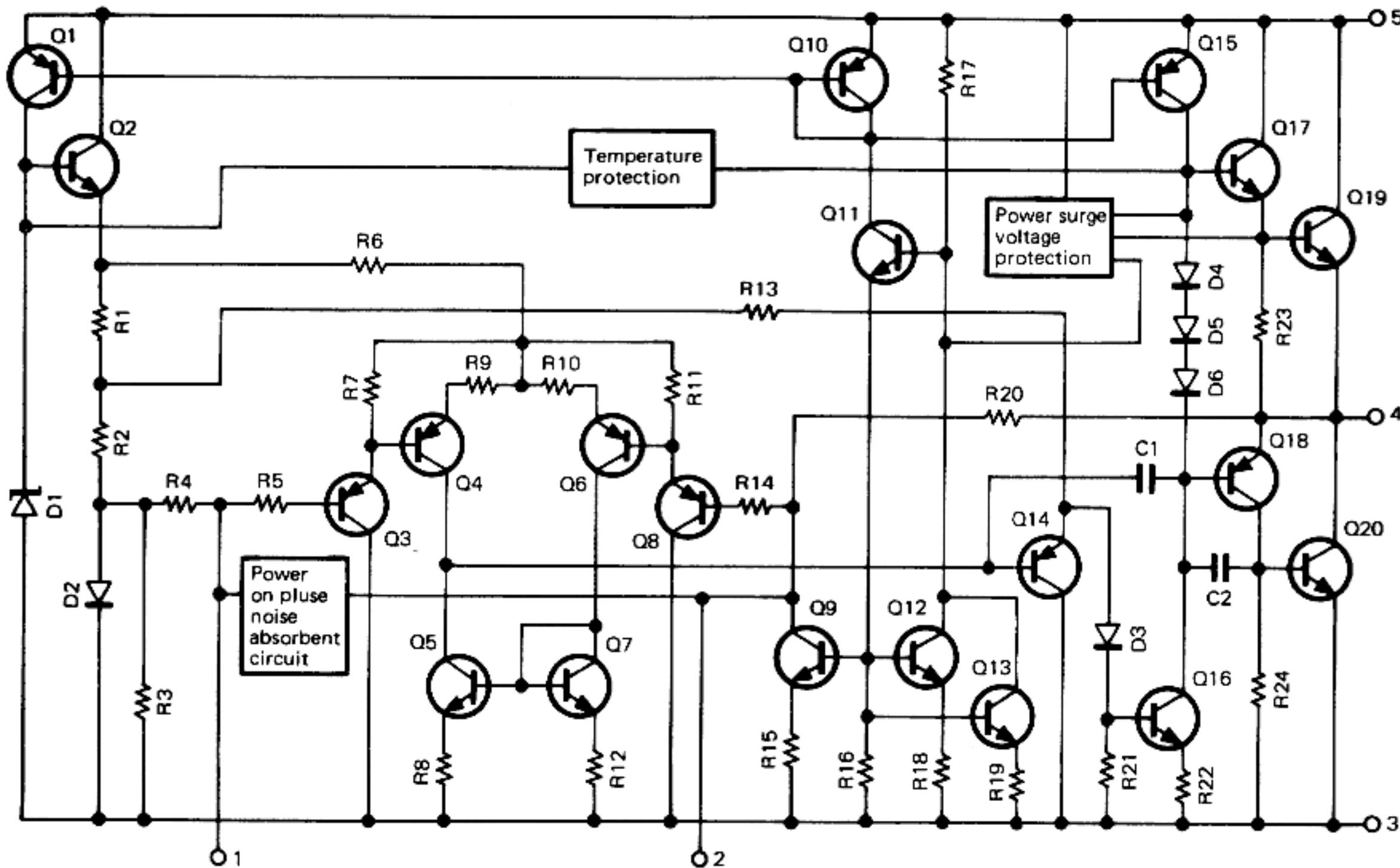

- 1 : Input
- 2 : NFB
- 3 : GND
- 4 : Output
- 5 : Power supply + Vcc

SEMICONDUCTOR

μPD8251AC (Control unit IC54)

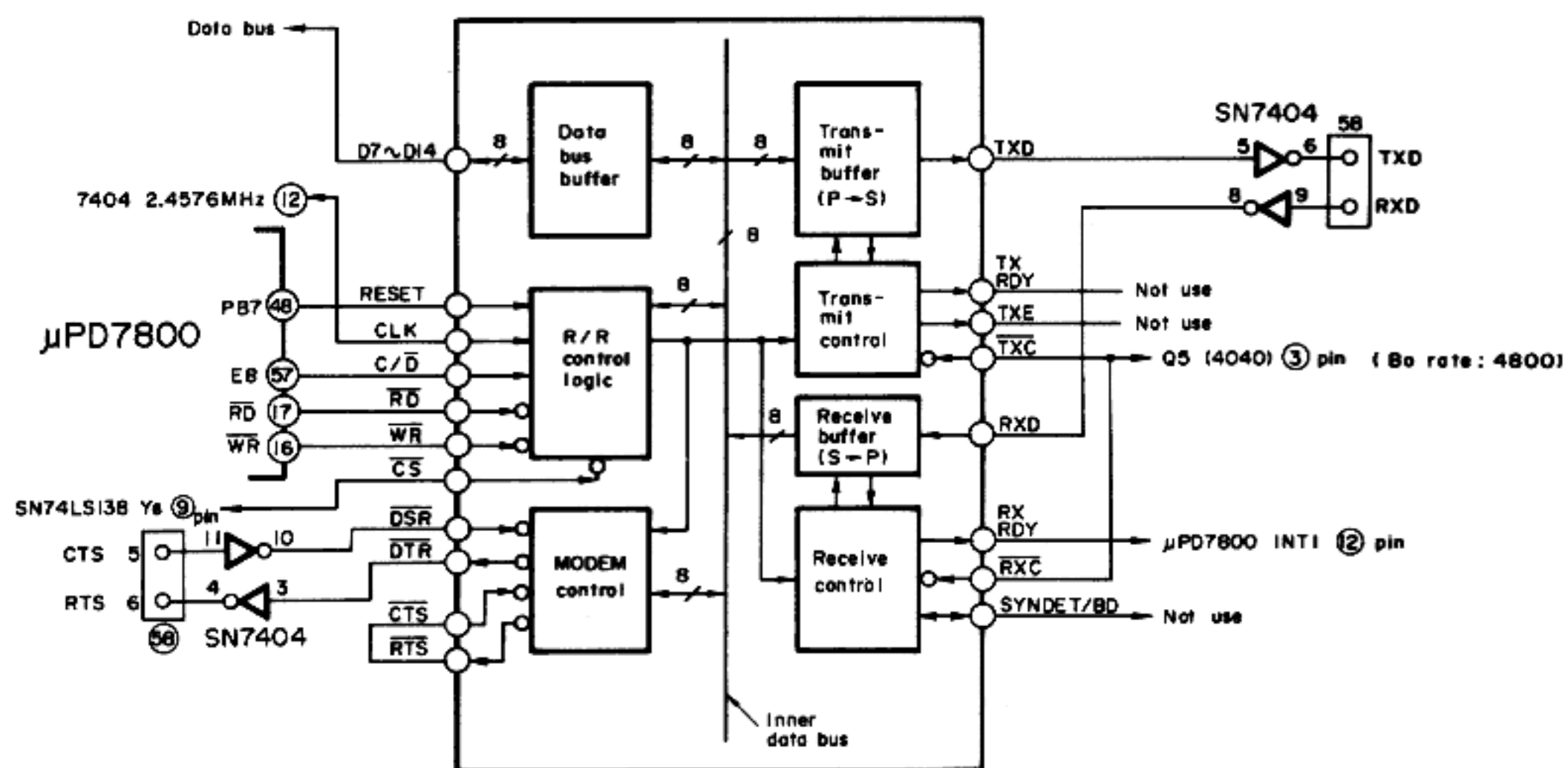

μPD8255AC-5 (Control unit IC2, 53)

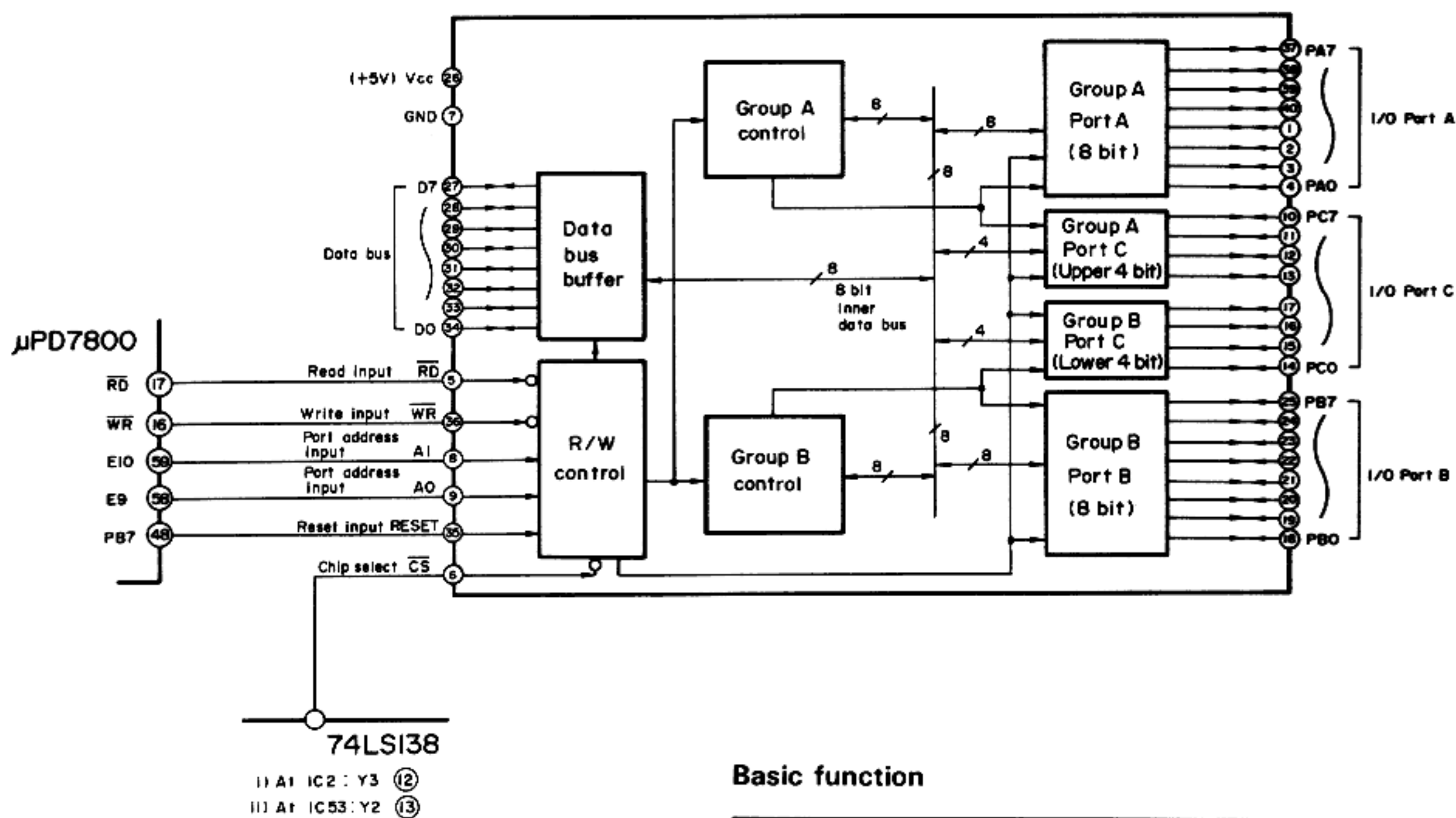

Basic function

A ₁	A ₀	\overline{CS}	\overline{RD}	\overline{WR}	Function
0	0	0	0	1	Data bus ← Port A
0	1	0	0	1	Data bus ← Port B
1	0	0	0	1	Data bus ← Port C
0	0	0	1	0	Port A ← Data bus
0	1	0	1	0	Port B ← Data bus
1	0	0	1	0	Port C ← Data bus
1	1	0	1	0	Control register ← Data bus
x	x	1	x	x	Data bus is in high impedance status
1	1	0	0	1	Combination is inhibited

"0" shows low level (L)

"1" shows high level (H)

SEMICONDUCTOR

μPD6300C (Display unit IC1)

Pin description

Pin No.	Symbol	Pin name	I/O	Description
1 7	O ₁₃ O ₁₄ O ₁₅ O ₁₆ O ₁₇ O ₁₈ O ₁₉	FIP Segment driver (O ₁₃ ~O ₁₉)	O	High dielectric-strength (40V) output in the Pch open. Corresponds to the output of O ₁₃ ~O ₁₉
8	SO	Serial data output pin	O	Output serial data the trailing edge of SCK. When the n-number of μPD6300Cs are connected in series, this can be connected to the SI of the following stage.
9	$\overline{\text{BI}}$	Blanking pin	I	This input can turn off all indicator or displays, and can dim them by applying a random duty pulse from outside. Active low.
10	$\overline{\text{LH}}$	Latch pin	I	Transmits the connects of the serial shift register to the buffer register at low level, to latch the connects at the rising time. Active rising (leading) edge.
11	SI	Serial data input pin	I	This is the data input pin. Inputs data to the shift register at the rising edge of SCK.
12	$\overline{\text{SCK}}$	Serial clock input pin	I	Reads out the SI data to the shift register at the rising edge of SCK. Outputs data from SO at the trailing edge of $\overline{\text{SCK}}$.
13	$\overline{\text{CS}}$	Chip select pin	I	When $\overline{\text{CS}}$ is high, this inhibits $\overline{\text{SCK}}$ and $\overline{\text{LH}}$, and when $\overline{\text{CS}}$ is low, activates SCK and LH.
14	V _{SS}	GND	—	Connect to the GND terminal of the system.
15 16 17 18 26 27	O ₀ O ₁ O ₂ O ₃ O ₄ O ₅ O ₆ O ₇ O ₈ O ₉ O ₁₀ O ₁₁ O ₁₂	FIP Segment driver (O ₀ ~O ₁₂)		Pch open-drain system, high dielectric-strength output. Corresponds to the output of O ₀ to O ₁₂
28	V _{DD}	Power supply pin	—	5 V ± 10%

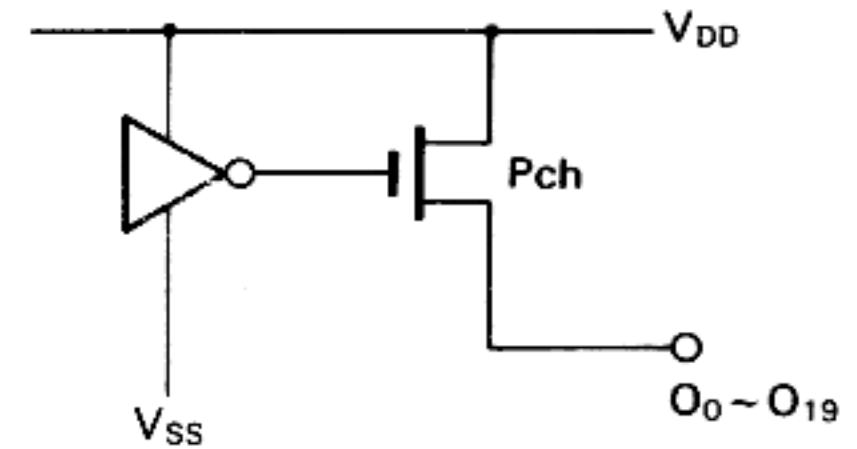

PARTS LIST

CAPACITORS

CC 45 TH 1H 220 J
 1 2 3 4 5 6

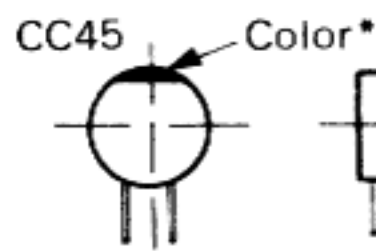

• Capacitor value

1 0 3 = 0.01μF

0 1 0 = 1pF

1 0 0 = 10pF

1 0 1 = 100pF

1 0 2 = 1000pF = 0.001μF

2 2 0 = 22pF
 1st number | Multiplier
 2nd number

- 1 = Type ceramic, electrolytic, etc.
- 2 = Shape round, square, etc.
- 3 = Temp. coefficient
- 4 = Voltage rating
- 5 = Value
- 6 = Tolerance

• Temperature Coefficient

1st Word	C	L	P	R	S	T	U
Color*	Black	Red	Orange	Yellow	Green	Blue	Violet
ppm/°C	0	-80	-150	-220	-330	-470	-750

2nd Word	G	H	J	K	L
ppm/°C	± 30	± 60	± 120	± 250	± 500

Example CC45TH = -470±60 ppm/°C

• Tolerance

Code	C	D	G	J	K	M	X	Z	P	No code
(%)	± 0.25	± 0.5	± 2	± 5	± 10	± 20	+ 40 - 20	+ 80 - 20	+ 100 - 0	More than Less than 10μF-10~+50 4.7μF-10~+75

Code	B	C	D	F	G
(pF)	± 0.1	± 0.25	± 0.5	± 1	± 2

Less than 10 pF

• Rating voltage

2nd word											
1st word	A	B	C	D	E	F	G	H	J	K	V
0	1.0	1.25	1.6	2.0	2.5	3.15	4.0	5.0	6.3	8.0	-
1	10	12.5	16	20	25	31.5	40	50	63	80	35
2	100	125	160	200	250	315	400	500	630	800	-
3	1000	1250	1600	2000	2500	3150	4000	5000	6300	8000	-

• Chip capacitors

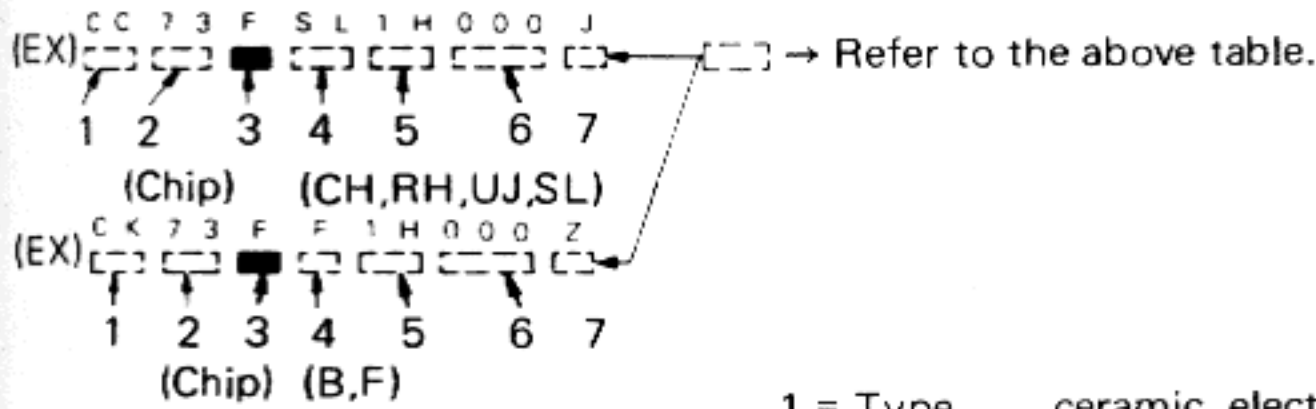

• Chip resistor (Carbon)

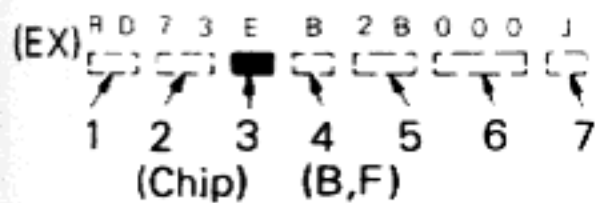

• Carbon resistor (Normal type)

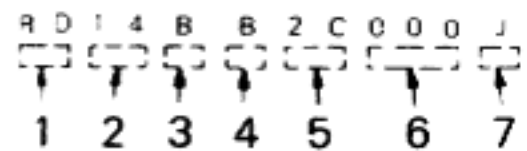

- 1 = Type ceramic, electrolytic, etc.
- 2 = Shape round, square, etc.
- 3 = Dimension
- 4 = Temp. coefficient
- 5 = Voltage rating
- 6 = Value
- 7 = Tolerance.

Dimension

Dimension code	L	W	T
Empty	5.6 ± 0.5	5.0 ± 0.5	Less than 2.0
E	3.2 ± 0.2	1.6 ± 0.2	Less than 1.25
F	2.0 ± 0.3	1.25 ± 0.2	Less than 1.25

Dimension

Dimension code	L	W	T	Wattage
E	3.2 ± 0.2	1.6 ± 0.2	0.57	2B
F	2.0 ± 0.3	1.25 ± 0.2	0.45	2A

Rating wattage

Cord	Wattage	Cord	Wattage	Cord	Wattage
2A	1 10W	2E	1 4W	3A	1W
2B	1 8W	2H	1 2W	3D	2W
2C	1 6W				

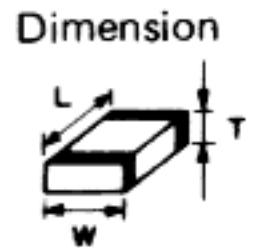

PARTS LIST

N: New Parts

*: Please note that parts are sometimes not in stock, and it takes much time to deliver.

SEMICONDUCTOR

Item	Re- marks	Name
Diode	N	1S1555
		1S133
		1S2588
		1S1587
		1S1007
		1SV53A
		1VS153
		1SS101
		1SS99
		1N60
	1N4448	
	N	S31C
		BA282
		MA858
		US1090
		DAN401
		MC931
MI204		
MC921		
Vari-cap		ITT310TE
Varistor		MV13
		MV-5T
		MV203
Zener diode	N	SV03YS
		MTZ 3.0JB
		MTZ 4.3JC
		MTZ 6.2JA
		MTZ 7.5JA
	MTZ 9.1JB	
	MTZ 9.1JC	
	N	UZ 3.0B
		UZ 6.2BL
		UZ 9.1BL
	V06B	
Thermistor	N	SDT1000
		5T41L
		112-502-2
		32D27
Surge absorber	N	DSP-301N

Item	Re- marks	Name	
Digital Tr	N	DTC114ES	
		DTC143TS	
		DTC124ES	
		DTC144WS	
		DTA114ES	
	TR	N	2SA562 (Y)
			2SA562 TM
			2SA950 (Y)
			2SC1959 (Y)
			2SC1815 (Y)
2SC2053			
2SC2075			
N		2SC2458 (Y)	
		2SC2459 (BL)	
		2SC2509	
		2SC2538	
		2SC2570A	
		2SC2668 (Y)	
		2SC2603 (E)	
		2SC2879	
FET	N	2SC3113 (B)	
		2SC2787 (L)	
		2SK30 (GR)	
		2SK30 (O)	
	N	2SK192 (GR)	
		2SK192A (GR)	
		2SK192A (GR)*J	
		2SK125-5	
IC	N	3SK73 (GR)	
		3SK74 (L)	
		3SK122 (L)	
		AN612	
		AN6551	
	N	AN7805	
		AN7808	
		BA718	
N	BA6109U2		
	BX6124		
	BX7191		
N	HD10116		
	HD10131		
	HD10125		

Item	Re- marks	Name
	N	LM2931Z-5.0
	N	M54460L
		M54459L
		M54561P
	N	M74LS00P
	N	M74LS123P
		M74LS145P
		MB3614
		MB4052
	N	MB87006
	N	MBM2718-25JA1
		MBM8418-20LP- GRA
		MC10125L
		MC10131L
		MC10116L
		MC3357P
		MN6147
		MN6147C
		NE555P
		NJM2903D
		NJM2903S
		NJM2904M
		NJM2094S
		PST520D
		SN74LS90N
		SN74LS10N
		SN74LS112N
	N	SN7404N
		SN74LS123N
	N	SN74LS00N
		SN74LS138N
		SN74LS145N
		SN16913P
	N	TC4001BF
		TC40118P
		TC4013BP
	N	TC4030BP
		TC4069UBP
	N	TMP8255AP-5
	N	μPC1158H2
		μPC2002V
		μPC4558C
		μPD6300C
		μPD8255AC-5
		μPD7800G

Destination table

- K : for U.S.A.
- M1 : GENERAL MARKET
- M2 : GENERAL MARKET
- T : for England
- W : for Europe
- X : for Australia

PARTS LIST

* New Parts

Parts without Parts No. are not supplied.

Les articles non mentionnes dans le Parts No. ne sont pas fournis.

Teile ohne Parts No. werden nicht geliefert.

Ref. No.	Address	New Parts	Parts No.	Description	Destination	Remarks
参照番号	位置	新	部品番号	部品名 / 規格	仕向	備考
TS-440						
1	1B	*	A01-0998-02	CASE (A) UPPER		
2	3A	*	A01-0999-02	CASE (B) LOWER		
3	2C	*	A20-2556-03	PANEL ASSY		
4	2B	*	A40-0617-03	BOTTOM PLATE		
9	1A		B04-0411-04	SP MOUNTING HARDWARE		
10	1A		B05-0708-04	SP GRILL CLOTH		
11	1F		B30-0817-15	PILOT LAMP (14V, 80MA)		
12	2H	*	B31-0657-05	METER		
14	3A	*	B40-3625-04	MODEL NAME PLATE		KM1M2
14	3A	*	B40-3625-04	MODEL NAME PLATE		TW
14	3A	*	B40-3626-04	MODEL NAME PLATE		X
17	1A	*	B42-2422-04	VOX NAME PLATE		
22	2C	*	B43-1063-04	NAME PLATE (TRIO TS-440S)		T
22	2C	*	B43-1064-04	NAME PLATE (KENWOOD TS-44X)		X
22	2C	*	B43-1065-04	NAME PLATE (KENWOOD TS-440S)		KM1M2
22	2C	*	B43-1065-04	NAME PLATE (KENWOOD TS-440S)		W
23	1T	*	B46-0410-10	WARRANTY CARD		K
24	1S	*	B50-8048-00	INSTRUCTION MANUAL		KM1M2
24	1S	*	B50-8048-00	INSTRUCTION MANUAL		WX
24	1S	*	B50-8049-00	INSTRUCTION MANUAL		T
			B42-1729-04	LABEL (WITH ANTENNA TUNER)		
26	1S		E07-0751-05	7P DIN PLUG (ACCESSORY)		
27	1S		E07-0852-05	8P METAL PLUG		KM1M2
28	1S		E30-1638-05	DC POWER CORD ASSY		
			E31-0431-15	WIRE WITH CONNECTOR (SP)		
30	1S		F05-2034-05	FUSE (20A)		
31	1S		F05-2034-05	FUSE (20A) ACCESSORY		
33	3C		G02-0505-05	KNOB FIXED SPRING (X4)		
			G53-0509-04	PACKING (X2) CASE SIDE		
34	3S		H01-4683-04	CARTON BOX (INSIDE)		KM1M2
34	3S		H01-4683-04	CARTON BOX (INSIDE)		W
34	3S	*	H01-4684-04	CARTON BOX (INSIDE)		T
34	3S	*	H01-4685-04	CARTON BOX (INSIDE)		X
35	3S	*	H03-2278-04	CARTON BOX (OUT SIDE)		
35	3S	*	H03-2278-04	CARTON BOX (OUT SIDE)		
35	3S	*	H03-2285-04	CARTON BOX (OUT SIDE)		
36	2S	*	H10-2615-02	PACKING FIXTURE (F)		
37	1T	*	H10-2616-02	PACKING FIXTURE (R)		
38	1S		H12-1315-04	CUSHION		
39	2T		H20-1425-03	PROTECTIVE COVER		
40	1S		H25-0079-04	PROTECTIVE BAG (MIC)		KM1M2
40	1S		H25-0079-04	PROTECTIVE BAG (MIC)		X
41	1S		H25-0112-04	PROTECTIVE BAG (DC CORD)		
43	3B		J02-0323-05	FOOT (X2) R		
44	3A	*	J02-0440-04	ASSISTANT FOOT		
45	1A, 3A		J02-0441-05	FOOT (X4)		
46	3A		J02-0442-04	FOOT (X2) F		
47	2A		J21-1144-34	MOUNTING HARDWARE (SP)		
48	1F	*	J21-2779-14	MOUNTING HARDWARE (PILOT LAMP)		
49	2E		J30-0526-04	SPACER		
50	2E		J31-0141-04	SPACER RING (MIC)		

PARTS LIST

* New Parts

Parts without Parts No. are not supplied.

Les articles non mentionnes dans le Parts No. ne sont pas fournis.

Telle ohne Parts No. werden nicht geliefert.

Ref. No. 参照番号	Address 位置	New Parts 新	Parts No. 部品番号	Description 部品名 / 規格	Desti- nation 仕向	Re- marks 備考
55	1E		J32-0765-04	HEX BOSS (X2) 6.5MM		
56	2F		J32-0782-04	HEX BOSS (X4) 11MM		
57	1F, 1G	*	J32-0792-04	HEX BOSS (X8) 10MM		
58	1G	*	J32-0793-04	HEX BOSS (X4) 11MM		
59	1I, 2J	*	J32-0794-04	HEX BOSS (X3) 5MM		
63	3B		K01-0407-05	CARRING HANDLE		
64	3C	*	K21-0778-02	MAIN KNOB		
65	3C		K23-0710-04	KNOB (INSIDE) X4		
66	1S		K23-0712-04	KNOB (V8X) X1		
67	3C		K23-0782-04	KNOB (SELECTIVITY) X1		
68	3C		K29-0741-24	KNOB (OUTSIDE) X4		
69	2C		K29-0758-04	PUSH KNOB (POWER) X1		
70	2C		K29-0782-05	KNOB (ALC)		
71	2C		K29-3001-04	PUSH KNOB (X4)		
72	2C		K29-3002-04	PUSH KNOB (X6)		
75	2L	*	N19-0601-14	FLAT WASHER		
76	2C		N19-0637-04	FLAT WASHER (MAIN KNOB)		
			N87-3008-46	BRAZIER HEAD TAPTITE SCREW(X1)		
			N87-3012-46	BRAZIER HEAD TAPTITE SCREW(X2)		
AA	2C, 2E		N09-0256-05	GND SCREW (X4)		
BB	2H		N09-0644-04	BIND SCREW (X6)		
CC	2M		N09-0658-04	ROUND SCREW (X5)		
DD	2C, 3C	*	N09-0699-05	SCREW (X6)		
E	2L		N30-2608-41	PAN HEAD MACHINE SCREW (X6)		
F	1E, 1F		N32-2606-46	FLAT HEAD MACHINE SCREW (X8)		
G	2C, 2D		N32-3004-46	FLAT HEAD MACHINE SCREW (X4)		
H	1C, 2D		N32-3006-46	FLAT HEAD MACHINE SCREW (X8)		
J	1A		N33-3006-41	ØVAL HEAD MACHINE SCREW (X4)SP		
K	1G, 1I		N35-2605-46	BINDING HEAD MACHINE SCREW(X8)		
L	1A, 3B		N35-3006-41	BINDING HEAD MACHINE SCREW(X20)		
M	1C, 1L		N87-2606-46	BRAZIER HEAD TAPTITE SCREW(X36)		
N	1C, 2K		N87-3006-46	BRAZIER HEAD TAPTITE SCREW(X13)		
P	3A		N87-3008-41	BRAZIER HEAD TAPTITE SCREW(X2)		
R	2L		N87-3010-41	BRAZIER HEAD TAPTITE SCREW(X2)		
T	3D		N35-3006-46	BINDING HEAD MACHINE SCREW		
U	1J		N30-2604-46	PAN HEAD MACHINE SCREW		
R1			RS14AB3A100J	FL-PRONE RS 10 J 1W		
79	2H	*	S59-0436-05	KEY BOARD ASSY		
S1	1E		S40-2437-05	PUSH SWITCH (POWER)		
S2			S50-1406-05	PUSH SWITCH (TACT)	KM1M2	
S2			S50-1406-05	PUSH SWITCH (TACT)	X	
80	2A		T03-0027-15	SPEAKER		
81	1S		T91-0352-05	MICROPHONE	KM1M2	
81	1S		T91-0352-05	MICROPHONE	X	
83	1F	*	W02-0373-05	FRONDER ASSY		
84	1S		W09-0326-05	LITHIUM BATTERY		
88	2D, 2G		X41-1610-00	SWITCH UNIT		
89	3D		X44-1680-00	RF UNIT		
90	2L, 10		X45-1470-00	FINAL UNIT		
91	2C		X50-2050-00	PII UNIT		
92	1L		X51-1340-00	FILTER UNIT		
93	1I, 2J	*	X53-1450-11	CONTROL UNIT	KM1M2	

PARTS LIST

* New Parts

Parts without Parts No. are not supplied.

Les articles non mentionnes dans le Parts No. ne sont pas fournis.

Teile ohne Parts No. werden nicht geliefert.

Ref. No. 参照番号	Address 位置	New Parts 新	Parts No. 部品番号	Description 部品名 / 規格	Desti- nation 仕 向	Re- marks 備考
93	1I,2J	*	X53-1450-11	CONTROL UNIT	WX M2	
93	1I,2J	*	X53-1450-21	CONTROL UNIT		
96	1K,1G	*	X54-1870-00	DISPLAY UNIT		
97	2D,1R	*	X57-1150-00	AT UNIT		
98	1D	*	X60-1300-00	IF UNIT		
SWITCH UNIT (X41-1610-00)						
C10 .11			CK45F1H473Z	CERAMIC 0.047UF Z		
C12			CE04W1C222M	ELECTRO 2200UF 16WV		
C13			CK45F1H473Z	CERAMIC 0.047UF Z		
C14			CE04W1C222M	ELECTRO 2200UF 16WV		
C15			CK45F1H473Z	CERAMIC 0.047UF Z		
C17			CE04W1C330M	ELECTRO 33UF 16WV		
C19 .20			CE04W1C330M	ELECTRO 33UF 16WV		
C23			CE04W1C330M	ELECTRO 33UF 16WV		
C24			CE04W1C470M	ELECTRO 47UF 16WV		
C26			CE04W1C330M	ELECTRO 33UF 16WV		
C30			CE04W1C470M	ELECTRO 47UF 16WV		
C31			CE04W1C330M	ELECTRO 33UF 16WV		
C34			CE04W1C330M	ELECTRO 33UF 16WV		
C35			C91-0119-05	CERAMIC 0.047UF K		
C38			CE04W1C470M	ELECTRO 47UF 16WV		
C39			C91-0117-05	CERAMIC 0.01UF K		
C41			C90-2035-05	ELECTRO 100UF 16WV		
C43			CK45F1H473Z	CERAMIC 0.047UF Z		
C45			C90-2035-05	ELECTRO 100UF 16WV		
C46			CB92M1H562K	MYLAR 5600PF K		
C48 .52			C91-0119-05	CERAMIC 0.047UF K		
C53			C91-0117-05	CERAMIC 0.01UF K		
C55 .56			C90-2035-05	ELECTRO 100UF 16WV		
C57		*	C90-2021-05	ELECTRO 10UF 25WV		
C59			CK45B1H471K	CERAMIC 470PF K		
C60 .61			CK45B1H102K	CERAMIC 1000PF K		
-			E23-0401-05	TERMINAL		
-			E23-0512-05	TERMINAL		
CN1			E06-0656-05	6P DIN CONNECTOR(ACC1)		
CN2			E11-0413-05	JACK (PHONES)		
CN4			E06-0858-05	8P METAL SOCKET (MIC)		
CN4			E11-0414-05	JACK (EXT SP)		
CN5		*	E11-0418-05	PHONE JACK (FSK IN,OUT,ACC3)		
CN6			E13-0362-05	PHONE JACK		
MC1			E40-0773-05	PIN CONNECTOR (MINI,7P)		
MC2			E40-1073-05	PIN CONNECTOR (MINI,10P)		
MC3			E40-1273-05	PIN CONNECTOR (MINI,12P)		
MC4			E40-0573-05	PIN CONNECTOR (MINI,5P)		
MC8			E40-0373-05	PIN CONNECTOR (MINI,3P)		
MC9 .10			E40-0273-05	PIN CONNECTOR (MINI,2P)		
MC12			E40-0873-05	PIN CONNECTOR (MINI,8P)		
MC13,14			E40-3237-05	PIN CONNECTOR (MINI,2P)		
MC15			E40-3239-05	PIN CONNECTOR (MINI,4P)		
MC16			E08-0373-05	MINI CONNECTOR (3P)		
MC17			E08-0272-05	MINI CONNECTOR (2P)		
MC18			E40-0473-05	PIN CONNECTOR (MINI,4P)		
MC19			E40-0373-05	PIN CONNECTOR (MINI,3P)		
MC20,21			E40-0473-05	PIN CONNECTOR (MINI,4P)		

PARTS LIST

× New Parts

Parts without Parts No. are not supplied.

Les articles non mentionnés dans le Parts No. ne sont pas fournis.

Teile ohne Parts No. werden nicht geliefert.

Ref. No. 参照番号	Address 位置	New Parts 新	Parts No. 部品番号	Description 部品名 / 規格	Desti- nation 仕向	Re- marks 備考
MC22			E40-0673-05	PIN CONNECTOR (MINI,6P)		
MC24			E40-0373-05	PIN CONNECTOR (MINI,3P)		
MC25			E40-5069-05	PIN CONNECTOR (MINI,6P)		
MC27			E40-3241-05	PIN CONNECTOR (MINI,12P)		
MC28			E04-0154-05	RF COAXIAL CABLE RECEPTACLE		
MC29			E40-0273-05	PIN CONNECTOR (MINI,2P)		
MC30			E40-0473-05	PIN CONNECTOR (MINI,4P)		
MC31			E40-0373-05	PIN CONNECTOR (MINI,3P)		
MC32, 33			E40-0273-05	PIN CONNECTOR (MINI,2P)		
MC34			E40-0473-05	PIN CONNECTOR (MINI,4P)		
-			F02-0423-04	HEAT SINK		
CH1			L15-0016-05	CHOKO COIL		
L1			L40-1011-13	SMALL FIXED INDUCTOR		
L3 -5			L40-1011-14	SMALL FIXED INDUCTOR		
-			N09-0641-05	SCREW (X4)		
-			N10-2030-46	HEXAGON NUT (X2)		
-			N17-1030-46	TOOTHED LOCK WASHER (X4)		
-			N30-3004-46	PAN HEAD MACHINE SCREW(X1)		
VR1		*	R19-3423-05	POTENTIOMETER (MIC,CAR)		
VR2		*	R24-9405-05	POTENTIOMETER (SQ,NOTCH)		
VR3			R12-1428-05	TRIMMING PBT. (1K)RIT		
VR4			R12-3450-05	TRIMMING PBT. (20K)VOLTAGE		
VR5			R19-3420-05	POTENTIOMETER (AF,RF)		
VR6			R19-3418-05	POTENTIOMETER (RIT,IF SHIFT)		
VR7			R12-1435-05	TRIMMING PBT. (2K)VCO4		
VR10			R12-0405-05	TRIMMING PBT. (330)		
VR11			R12-5402-05	TRIMMING PBT. (220K)		
VR12		*	R12-3435-05	TRIMMING PBT. (47K)		
VR13			R12-1418-05	TRIMMING PBT. (1K)		
VR14			R12-1419-05	TRIMMING PBT. (1K)		
W1 -2			R92-0150-05	JUMPER REST 0 OHM		
W7			R92-0150-05	JUMPER REST 0 OHM		
W13			R92-0150-05	JUMPER REST 0 OHM		
W15			R92-0150-05	JUMPER REST 0 OHM		
RL1		*	S51-1429-05	RELAY		
RL2			S51-1420-05	RELAY		
S1			S01-2425-05	ROTARY SWITCH (SELECT)		
S2		*	S31-4405-05	SLIDE SWITCH		
D1			1S1555	DIODE		
D2			MTZ7.5JA	ZENER DIODE		
D5 -12			1SS133	DIODE		
D13			S31C	DIODE		
D15 -18			1SS133	DIODE		
IC1			AN7808	IC(VOLTAGE REGULATOR/ +8V)		
IC2 -3			AN7805	IC(VOLTAGE REGULATOR/ +5V)		
IC4		*	LM2931Z-5.0	IC(DRAMP/OUT CONTROL)/ +5V)		
IC5			NJM2904S	IC(OP AMP X2)		
IC6			AN7805	IC(VOLTAGE REGULATOR/ +5V)		
IC7			NJM2903S	IC(DUAL COMPALATOR)		
IC8			NJM2904S	IC(OP AMP X2)		
Q1			DTC114ES	DIGITAL TRANSISTOR		
Q2			2SD1406(Y)	TRANSISTOR		
Q3 -4			2SK30(GR)	FET		

PARTS LIST

* New Parts

Parts without Parts No. are not supplied.

Les articles non mentionnés dans le Parts No. ne sont pas fournis.

Teile ohne Parts No. werden nicht geliefert.

Ref. No. 参照番号	Address 位置	New Parts 新	Parts No. 部品番号	Description 部品名/規格	Desti- nation 仕向	Re- marks 備考
Q5	.6		29C2458(Y)	TRANSISTOR		
RF UNIT (X44-1680-00)						
C1			CC45SL1H390J	CERAMIC	39PF	J
C2			CC45SL1H121J	CERAMIC	120PF	J
C3			CC45RH1H330J	CERAMIC	33PF	J
C4			CK45F1H473Z	CERAMIC	0.047UF	Z
C6			C91-1008-05	CERAMIC	0.022UF	K
C7			C91-0117-05	CERAMIC	0.01UF	K
C8		*	C91-1065-05	CERAMIC	0.0068UF	K
C9	.10		C91-0117-05	CERAMIC	0.01UF	K
C11			CK45F1H103Z	CERAMIC	0.010UF	Z
C12			C91-0117-05	CERAMIC	0.01UF	K
C13			C91-0105-05	CERAMIC	0.0047UF	K
C14			CO92M1H123K	MYLAR	0.012UF	K
C15	.16		CO92M1H153K	MYLAR	0.015UF	K
C17			CE04W1H010M	ELECTRO	1.0UF	SOWV
C18			C91-1008-05	CERAMIC	0.022UF	K
C19	.20		CO92M1H153K	MYLAR	0.015UF	K
C21			CK45B1H152K	CERAMIC	1500PF	K
C22			C91-0125-05	CERAMIC	0.0027UF	K
C23			CK45B1H152K	CERAMIC	1500PF	K
C24			CE04WC1H010M	ELECTRO	HO1UF	C1
C25			C91-1008-05	CERAMIC	0.022UF	K
C26			CE04WC1H010M	ELECTRO	HO1UF	C1
C27			C91-1008-05	CERAMIC	0.022UF	K
C28	.29		CK45B1H222K	CERAMIC	2200PF	K
C30			CK45B1H821K	CERAMIC	820PF	K
C31		*	C91-1064-05	CERAMIC	0.0039UF	K
C32			C91-0119-05	CERAMIC	0.047UF	K
C33			CK45B1H821K	CERAMIC	820PF	K
C34			CE04W1H010M	ELECTRO	1.0UF	SOWV
C35			C91-1008-05	CERAMIC	0.022UF	K
C37			CK45B1H152K	CERAMIC	1500PF	K
C38			CK45B1H681K	CERAMIC	680PF	K
C39		*	C91-1063-05	CERAMIC	0.0033UF	K
C40			CK45B1H561K	CERAMIC	560PF	K
C41			CK45B1H152K	CERAMIC	1500PF	K
C42			C91-0119-05	CERAMIC	0.047UF	K
C43			CE04W1H010M	ELECTRO	1.0UF	SOWV
C44			C91-1008-05	CERAMIC	0.022UF	K
C45			CK45B1H182K	CERAMIC	1800PF	K
C46			CC45SL1H331J	CERAMIC	330PF	J
C47		*	C91-1063-05	CERAMIC	0.0033UF	K
C48			CC45SL1H271J	CERAMIC	270PF	J
C49			CK45B1H152K	CERAMIC	1500PF	K
C50			C91-0119-05	CERAMIC	0.047UF	K
C51			CE04W1H010M	ELECTRO	1.0UF	SOWV
C52			C91-1008-05	CERAMIC	0.022UF	K
C53			CK45B1H152K	CERAMIC	1500PF	K
C54			CC45CH1H101J	CERAMIC	100PF	J
C55			C91-0125-05	CERAMIC	0.0027UF	K
C56			CC45SL1H101J	CERAMIC	100PF	J
C57			CK45B1H122K	CERAMIC	1200PF	K
C58			C91-0119-05	CERAMIC	0.047UF	K

PARTS LIST

× New Parts

Parts without Parts No. are not supplied.

Les articles non mentionnés dans le Parts No. ne sont pas fournis.

Teile ohne Parts No. werden nicht geliefert.

Ref. No. 参照番号	Address 位置	New Parts 新	Parts No. 部品番号	Description 部品名 / 規格	Desti- nation 仕 向	Re- marks 備考
C59			CE04W1H010M	ELECTRO	1.0UF	50WV
C60			C91-1008-05	CERAMIC	0.022UF	K
C61			CK45B1H681K	CERAMIC	680PF	K
C62			CC45SL1H151J	CERAMIC	150PF	J
C63			CK45B1H152K	CERAMIC	1500PF	K
C64			CC45SL1H151J	CERAMIC	150PF	J
C65			C91-0119-05	CERAMIC	0.047UF	K
C66			CE04W1H010M	ELECTRO	1.0UF	50WV
C67			C91-1008-05	CERAMIC	0.022UF	K
C68			CK45B1H471K	CERAMIC	470PF	K
C69		*	CC45SL1H111J	CERAMIC	110PF	J
C70			CK45B1H821K	CERAMIC	820PF	K
C71			CC45SL1H151J	CERAMIC	150PF	J
C72			CK45B1H471K	CERAMIC	470PF	K
C73			C91-0119-05	CERAMIC	0.047UF	K
C74			CE04W1H010M	ELECTRO	1.0UF	50WV
C75			C91-1008-05	CERAMIC	0.022UF	K
C76			CC45SL1H221J	CERAMIC	220PF	J
C77			CC45SL1H910J	CERAMIC	91PF	J
C78			CK45B1H681K	CERAMIC	680PF	K
C79			CC45SL1H910J	CERAMIC	91PF	J
C80			CC45SL1H331J	CERAMIC	330PF	J
C81			C91-0119-05	CERAMIC	0.047UF	K
C82			CE04W1H010M	ELECTRO	1.0UF	50WV
C83			C91-1008-05	CERAMIC	0.022UF	K
C84			CC45SL1H121J	CERAMIC	120PF	J
C85 ,86			CC45SL1H470J	CERAMIC	47PF	J
C87			CC45SL1H080D	CERAMIC	8.0PF	D
C88			CC45SL1H820J	CERAMIC	82PF	J
C89			C91-0119-05	CERAMIC	0.047UF	K
C90			CE04W1H010M	ELECTRO	1.0UF	50WV
C91			C91-1008-05	CERAMIC	0.022UF	K
C92		*	CE04W1H010M	ELECTRO	101UF	C1
C93			C91-1008-05	CERAMIC	0.022UF	K
C94			CC45SL1H680J	CERAMIC	68PF	J
C95			CK45B1H181K	CERAMIC	180PF	K
C96			C91-1008-05	CERAMIC	0.022UF	K
C97 ,98			C91-0105-05	CERAMIC	0.0047UF	K
C99 ,100			C91-1008-05	CERAMIC	0.022UF	K
C101			C91-0119-05	CERAMIC	0.047UF	K
C103			CC45SL1H330J	CERAMIC	33PF	J
C104			C91-0117-05	CERAMIC	0.01UF	K
C105			C91-0119-05	CERAMIC	0.047UF	K
C106-108			C91-0117-05	CERAMIC	0.01UF	K
C109			C91-0769-05	CERAMIC	0.01UF	M
C110			C91-1008-05	CERAMIC	0.022UF	K
C111			C91-0117-05	CERAMIC	0.01UF	K
C112			CK45B1H102K	CERAMIC	1000PF	K
C113			C91-0117-05	CERAMIC	0.01UF	K
C114			C91-0769-05	CERAMIC	0.01UF	M
C115,116			C91-0117-05	CERAMIC	0.01UF	K
C117			C91-1008-05	CERAMIC	0.022UF	K
C118			C91-0117-05	CERAMIC	0.01UF	K
C119			C91-0757-05	CERAMIC	0.001UF	K
C120			CC45SL1H470J	CERAMIC	47PF	J

PARTS LIST

* New Parts

Parts without Parts No. are not supplied.

Les articles non mentionnés dans le Parts No. ne sont pas fournis.

Teile ohne Parts No. werden nicht geliefert.

Ref. No. 参照番号	Address 位置	New Parts 新	Parts No. 部品番号	Description 部品名 / 規格	Desti- nation 仕向	Re- marks 備考
C121			C91-0117-05	CERAMIC 0.01UF K		
C122			CC45SL1H470J	CERAMIC 47PF J		
C123			C91-0769-05	CERAMIC 0.01UF M		
C124			CC45SL1H100D	CERAMIC 10PF D		
C125			C91-0117-05	CERAMIC 0.01UF K		
C126			CE04W1H100M	ELECTR0 10UF 50WV		
C127			C91-0117-05	CERAMIC 0.01UF K		
C128			CC45SL1H040C	CERAMIC 4.0PF C		
C129-132			C91-0117-05	CERAMIC 0.01UF K		
C133			CC45SL1H101J	CERAMIC 100PF J		
C134			C91-0117-05	CERAMIC 0.01UF K		
C135			CC45SL1H121J	CERAMIC 120PF J		
C136			C91-0117-05	CERAMIC 0.01UF K		
C137			C91-0769-05	CERAMIC 0.01UF M		
C138-142			C91-0117-05	CERAMIC 0.01UF K		
C143-145			C91-0769-05	CERAMIC 0.01UF M		
C146			C91-0117-05	CERAMIC 0.01UF K		
C147,148			C91-1008-05	CERAMIC 0.022UF K		
C149,150			C91-0769-05	CERAMIC 0.01UF M		
C151			C91-0117-05	CERAMIC 0.01UF K		
C153			C91-1008-05	CERAMIC 0.022UF K		
C154,155			C91-0769-05	CERAMIC 0.01UF M		
C156			CC45RH1H020C	CERAMIC 2.0PF C		
C157			C91-1008-05	CERAMIC 0.022UF K		
C158			CC45SL1H100D	CERAMIC 10PF D		
C159			CC45SL1H120J	CERAMIC 12PF J		
C160			C91-1008-05	CERAMIC 0.022UF K		
C161			C91-0119-05	CERAMIC 0.047UF K		
C162			CE04W1H2R2M	ELECTR0 2.2UF 50WV		
C163			C91-0119-05	CERAMIC 0.047UF K		
C164			CK45B1H181K	CERAMIC 180PF K		
C165			CK45B1H331K	CERAMIC 330PF K		
C166			C91-0117-05	CERAMIC 0.01UF K		
C166,167			C91-0117-05	CERAMIC 0.01UF K		
C168			CE04W1H100M	ELECTR0 10UF 50WV		
C169			C91-0119-05	CERAMIC 0.047UF K		
C170			CE04W1A470M	ELECTR0 47UF 10WV		
C171			C91-0117-05	CERAMIC 0.01UF K		
C172			CE04W1A470M	ELECTR0 47UF 10WV		
C173			C91-0769-05	CERAMIC 0.01UF M		
C174			CC45TH1H390J	CERAMIC 39PF J		
C175			CC45CH1H050C	CERAMIC 5.0PF C		
C176			CC45CH1H330J	CERAMIC 33PF J		
C177		*	C91-0727-05	CERAMIC 18PF J		
C178			C91-0117-05	CERAMIC 0.01UF K		
C179			CE04W1A470M	ELECTR0 47UF 10WV		
C180			C91-0769-05	CERAMIC 0.01UF M		
C181		*	CC45SH1H470J	CERAMIC 47PF J		
C182			CC45CH1H050C	CERAMIC 5.0PF C		
C183			CC45CH1H330J	CERAMIC 33PF J		
C184			C91-0117-05	CERAMIC 0.01UF K		
C185			CE04W1A470M	ELECTR0 47UF 10WV		
C186			C91-0769-05	CERAMIC 0.01UF M		
C187			CC45RH1H560J	CERAMIC 56PF J		
C188			CC45CH1H050C	CERAMIC 5.0PF C		

PARTS LIST

* New Parts

Parts without Parts No. are not supplied.

Les articles non mentionnes dans le Parts No. ne sont pas fournis.

Teile ohne Parts No. werden nicht geliefert.

Ref. No. 参照番号	Address 位置	New Parts 新	Parts No. 部品番号	Description 部品名 / 規格	Desti- nation 仕 向	Re- marks 備考
C189			CC45CH1H330J	CERAMIC 33PF J		
C190, 191			C91-0117-05	CERAMIC 0.01UF K		
C192			CE04W1A470M	ELECTR0 47UF 10WV		
C193			C91-0769-05	CERAMIC 0.01UF M		
C194			CC45RH1H680J	CERAMIC 68PF J		
C195			CC45CH1H050C	CERAMIC 5.0PF C		
C196			CC45CH1H330J	CERAMIC 33PF J		
C197			CC45CH1H050C	CERAMIC 5.0PF C		
C198			CK45F1H103Z	CERAMIC 0.010UF Z		
C199			CC45SL1H220J	CERAMIC 22PF J		
C200			C91-0117-05	CERAMIC 0.01UF K		
C202			CC45SL1H330J	CERAMIC 33PF J		
C203			C91-0119-05	CERAMIC 0.047UF K		
C204			C91-0117-05	CERAMIC 0.01UF K		
C205			C91-0747-05	CERAMIC 150PF K		
C206			CC45SL1H270J	CERAMIC 27PF J		
C207			CC45SL1H331J	CERAMIC 330PF J		
C208			CC45SL1H470J	CERAMIC 47PF J		
C209-213			C91-0117-05	CERAMIC 0.01UF K		
C214		*	C91-0714-05	CERAMIC 2.7PF K		
C215, 216			C91-0117-05	CERAMIC 0.01UF K		
C217			CK45B1H102K	CERAMIC 1000PF K		
C218			CK45B1H331K	CERAMIC 330PF K		
C219			CE04W1H010M	ELECTR0 1.0UF 50WV		
C220			C91-0117-05	CERAMIC 0.01UF K		
C221			C91-0117-05	CERAMIC 0.01UF K		
C222, 223			C91-0119-05	CERAMIC 0.047UF K		
C224			CE04W1H010M	ELECTR0 1.0UF 50WV		
C225			C91-0117-05	CERAMIC 0.01UF K		
C226			CE04W1H010M	ELECTR0 1.0UF 50WV		
C227			CC45SL1H101J	CERAMIC 100PF J		
C228			C91-0117-05	CERAMIC 0.01UF K		
C229			CS15E1VR47M	TANTAL 0.47UF 35WV		
C230			C092M1H392K	MYLAR 3900PF K		
C231			CE04W1A470M	ELECTR0 47UF 10WV		
C232			CE04W1HOR1M	ELECTR0 0.1UF 50WV		
C233			CK45B1H471K	CERAMIC 470PF K		
C235			CE04W1H100M	ELECTR0 10UF 50WV		
C236			C092M1H333K	MYLAR 0.033UF K		
C237			CE04W1H100M	ELECTR0 10UF 50WV		
C238			CS15E1A2R2M	TANTAL 2.2UF 10WV		
C239			C092M1H102K	MYLAR 1000PF K		
C240			C092M1H123K	MYLAR 0.012UF K		
C241			CK45F1H223Z	CERAMIC 0.022UF Z		
C242-247			C91-0769-05	CERAMIC 0.01UF M		
C249			CC45SL1H470J	CERAMIC 47PF J		
C250			CC45RH1H020C	CERAMIC 2.0PF C		
C251			C91-0119-05	CERAMIC 0.047UF K		
C252		*	CE04WC1H010M	ELECTR0 101UF 01		
C253, 254			C91-1008-05	CERAMIC 0.022UF K		
TC1			C05-0328-05	TRIMMING CAP (50PF)		
-			E04-0157-05	RF COAXIAL CABLE RECEPTACLE(X3		
-			E23-0512-05	TERMINAL		
-			E31-1448-05	CONNECTING WIRE		

PARTS LIST

* New Parts

Parts without Parts No. are not supplied.

Les articles non mentionnés dans le Parts No. ne sont pas fournis.

Teile ohne Parts No. werden nicht geliefert.

Ref. No. 参照番号	Address 位置	New Parts 新	Parts No. 部品番号	Description 部品名 / 規格	Desti- nation 仕 向	Re- marks 備考
J1			E40-1173-05	PIN CONNECTOR		
J2			E40-0473-05	PIN CONNECTOR (MINI,4P)		
J3 ,4			E40-0273-05	PIN CONNECTOR (MINI,2P)		
J6			E40-0573-05	PIN CONNECTOR		
J7 -9			E40-0273-05	PIN CONNECTOR (MINI,2P)		
J11			E40-0273-05	PIN CONNECTOR (MINI,2P)		
J12			E40-0473-05	PIN CONNECTOR (MINI,4P)		
J14			E40-0373-05	PIN CONNECTOR (MINI,3P)		
J14			E40-0673-05	PIN CONNECTOR		
J15 ,16			E40-0473-05	PIN CONNECTOR (MINI,4P)		
-			J32-0795-04	HEX BOSS		
-			L92-0110-05	BEAD CORE (FOR L77,L78)		
F1		*	L71-0259-05	CRYSTAL FILTER (45.05MHZ)		
F2		*	L71-0260-05	CRYSTAL FILTER (8.83MHZ)		
L1			L40-1511-13	SMALL FIXED INDUCTOR(150UH)		
L3			L40-3382-14	SMALL FIXED INDUCTOR(0.33UH)		
L4			L40-2282-14	SMALL FIXED INDUCTOR(0.22UH)		
L5 -8			L40-2292-14	SMALL FIXED INDUCTOR(1.2UH)		
L9			L40-1011-13	SMALL FIXED INDUCTOR(100UH)		
L10			L40-1021-03	SMALL FIXED INDUCTOR(1MHZ)		
L11			L40-1021-13	SMALL FIXED INDUCTOR(1MHZ)		
L12 ,13			L40-2701-14	SMALL FIXED INDUCTOR(27UH)		
L14			L40-2201-14	SMALL FIXED INDUCTOR(22UH)		
L15 ,16			L40-4701-14	SMALL FIXED INDUCTOR(47UH)		
L17			L40-1001-14	SMALL FIXED INDUCTOR(10UH)		
L18			L40-8291-14	SMALL FIXED INDUCTOR(8.2UH)		
L20			L40-8291-14	SMALL FIXED INDUCTOR(8.2UH)		
L21			L40-2792-14	SMALL FIXED INDUCTOR(2.7UH)		
L22			L40-1592-14	SMALL FIXED INDUCTOR(1.5UH)		
L23			L40-8291-14	SMALL FIXED INDUCTOR(8.2UH)		
L24			L40-1021-13	SMALL FIXED INDUCTOR(1MHZ)		
L25			L40-2792-14	SMALL FIXED INDUCTOR(2.7UH)		
L26 ,27			L40-5691-14	SMALL FIXED INDUCTOR(5.6UH)		
L28			L40-1892-14	SMALL FIXED INDUCTOR(1.8UH)		
L29			L40-1092-14	SMALL FIXED INDUCTOR(1UHZ)		
L30			L40-1892-14	SMALL FIXED INDUCTOR(1.8UH)		
L31			L40-1021-13	SMALL FIXED INDUCTOR(1MHZ)		
L32 ,33			L40-3991-14	SMALL FIXED INDUCTOR(3.9UH)		
L34			L40-6882-14	SMALL FIXED INDUCTOR(0.68UH)		
L35			L40-3982-14	SMALL FIXED INDUCTOR(0.39UH)		
L36			L40-6882-14	SMALL FIXED INDUCTOR(0.68UH)		
L37			L40-1021-13	SMALL FIXED INDUCTOR(1MHZ)		
L38 ,39			L40-5691-14	SMALL FIXED INDUCTOR(5.6UH)		
L40			L40-3982-14	SMALL FIXED INDUCTOR(0.39UH)		
L41			L40-2282-14	SMALL FIXED INDUCTOR(0.22UH)		
L42			L40-3982-14	SMALL FIXED INDUCTOR(0.39UH)		
L43			L40-1021-13	SMALL FIXED INDUCTOR(1MHZ)		
L44 ,45			L40-2292-14	SMALL FIXED INDUCTOR(1.2UH)		
L46			L40-4782-14	SMALL FIXED INDUCTOR(0.47UH)		
L47		*	L40-2782-14	SMALL FIXED INDUCTOR(0.27UH)		
L48			L40-4782-14	SMALL FIXED INDUCTOR(0.47UH)		
L49			L40-1021-13	SMALL FIXED INDUCTOR(1MHZ)		
L50			L40-1592-14	SMALL FIXED INDUCTOR(1.5UH)		
L51			L40-1092-14	SMALL FIXED INDUCTOR(1UHZ)		

PARTS LIST

* New Parts

Parts without Parts No. are not supplied.

Les articles non mentionnes dans le Parts No. ne sont pas fournis.

Teile ohne Parts No. werden nicht geliefert.

Ref. No. 参照番号	Address 位置	New Parts 新	Parts No. 部品番号	Description 部品名 / 規格	Desti- nation 仕向	Re- marks 備考
L52			L40-3982-14	SMALL FIXED INDUCTOR(0.39UH)		
L53			L40-2282-14	SMALL FIXED INDUCTOR(0.22UH)		
L54			L40-3982-14	SMALL FIXED INDUCTOR(0.39UH)		
L55			L40-1021-13	SMALL FIXED INDUCTOR(1MHZ)		
L56 ,57			L40-1092-14	SMALL FIXED INDUCTOR(1UHZ)		
L58			L40-3982-14	SMALL FIXED INDUCTOR(0.39UH)		
L59		*	L34-1163-05	COIL		
L60			L40-3982-14	SMALL FIXED INDUCTOR(0.39UH)		
L61			L40-1021-13	SMALL FIXED INDUCTOR(1MHZ)		
L62		*	L40-2782-14	SMALL FIXED INDUCTOR(0.27UH)		
L63			L40-8282-14	SMALL FIXED INDUCTOR(0.82UH)		
L64			L40-2282-14	SMALL FIXED INDUCTOR(0.22UH)		
L65			L40-3982-14	SMALL FIXED INDUCTOR(0.39UH)		
L66			L40-1021-13	SMALL FIXED INDUCTOR(1MHZ)		
L67			L40-1021-03	SMALL FIXED INDUCTOR(1MHZ)		
L68			L40-2211-03	SMALL FIXED INDUCTOR		
L69			L40-3382-14	SMALL FIXED INDUCTOR(0.33UH)		
L70			L40-1011-14	SMALL FIXED INDUCTOR(100UH)		
L71			L40-4701-03	SMALL FIXED INDUCTOR(47UH)		
L72 -76			L40-1011-14	SMALL FIXED INDUCTOR(100UH)		
L79 -84			L40-1011-14	SMALL FIXED INDUCTOR(100UH)		
L86			L40-1011-14	SMALL FIXED INDUCTOR(100UH)		
L87			L40-2201-14	SMALL FIXED INDUCTOR(22UH)		
L88			L40-6891-14	SMALL FIXED INDUCTOR(6.8UH)		
L89			L40-2292-14	SMALL FIXED INDUCTOR(1.2UH)		
L90		*	L34-1162-05	COIL		
L91			L40-1011-14	SMALL FIXED INDUCTOR(100UH)		
L92		*	L40-6891-14	SMALL FIXED INDUCTOR(6.8UH)		
L93 -96			L40-4701-14	SMALL FIXED INDUCTOR(47UH)		
L97			L40-1011-14	SMALL FIXED INDUCTOR(100UH)		
L98			L40-1511-14	SMALL FIXED INDUCTOR(150UH)		
L99 -84			L40-1011-14	SMALL FIXED INDUCTOR(100UH)		
L100			L40-4782-14	SMALL FIXED INDUCTOR(0.47UH)		
L101			L40-1011-14	SMALL FIXED INDUCTOR(100UH)		
L102			L40-3382-14	SMALL FIXED INDUCTOR(0.33UH)		
L103			L40-2282-14	SMALL FIXED INDUCTOR(0.22UH)		
L104,105			L40-3382-14	SMALL FIXED INDUCTOR(0.33UH)		
L106			L40-1511-14	SMALL FIXED INDUCTOR(150UH)		
L107			L40-1021-13	SMALL FIXED INDUCTOR(1MHZ)		
L108			L40-1011-14	SMALL FIXED INDUCTOR(100UH)		
L109			L40-1011-13	SMALL FIXED INDUCTOR(100UH)		
L110-111			L40-1011-14	SMALL FIXED INDUCTOR(100UH)		
L112-115			L40-4701-13	SMALL FIXED INDUCTOR(47UH)		
T1		*	L34-2266-05	COIL (45.05MHZ)		
T2		*	L19-0361-05	RALIN TRANSFORMER(RX MIX)		
T3			L34-2267-05	COIL (45.05MHZ)		
T4			L34-2268-05	COIL (45.05MHZ)		
T5			L34-2145-05	COIL (45.05MHZ)		
T6		*	L34-2283-05	COIL (45.05MHZ)		
T7			L34-2267-05	COIL (45.05MHZ)		
T8			L30-0506-05	IFT (8.83MHZ)		
T9			L34-2159-05	COIL (8.83MHZ)		
T10 ,11			L34-0942-05	COIL (8.83MHZ)		
T12		*	L34-2284-05	COIL (8.83MHZ)		
T13		*	L34-2285-05	COIL (8.83MHZ)		

PARTS LIST

* New Parts

Parts without Parts No. are not supplied.

Les articles non mentionnés dans le Parts No. ne sont pas fournis.

Teile ohne Parts No. werden nicht geliefert.

Ref. No. 参照番号	Address 位置	New Parts 新	Parts No. 部品番号	Description 部品名 / 規格	Desti- nation 仕向	Re- marks 備考
T14		*	L34-2286-05	COIL (36.22MHZ)		
T15		*	L34-2287-05	COIL (36.22MHZ)		
T16		*	L34-2288-05	COIL (45.05MHZ)		
T17		*	L34-2289-05	COIL (45.05MHZ)		
T18 ,19			L19-0324-05	BALUN TRANSFORMER(TX MIX,DRIVE)		
T20		*	L19-0362-05	BALUN TRANSFORMER(TX DRIVE)		
T21 ,22		*	L34-2290-05	COIL (VCO,HH. H)		
T23		*	L34-2277-05	COIL (VCO L)		
T24		*	L34-2278-05	COIL (VCO LL)		
T25			L19-0344-05	BALUN TRANSFORMER(PLL)		
T26			L34-0535-05	COIL (8.83MHZ)		
T27			L34-0536-05	COIL (8.83MHZ)		
-			N10-2026-46	HEX NUT		
IB1			R90-0188-05	MULTI-COMP 0.01UF X4		
R184		*	R90-0454-05	MULTI-COMP		
VR1		*	R12-0435-05	TRIMMING PQT. (1ST MIX BALANCE)		
VR2			R12-1431-05	TRIMMING PQT. (2ND MIX BALANCE)		
VR3			R12-4413-05	TRIMMING PQT. (FM DEV)		
VR4			R12-1431-05	TRIMMING PQT. (SQUARIUS)		
VR5			R12-4414-05	TRIMMING PQT. (TX AMP)		
VR6			R12-3447-05	TRIMMING PQT. (FM DEV)		
W5			R92-0150-05	JUMPER REST 0 OHM		
W23			R92-0150-05	JUMPER REST 0 OHM		
W27			R92-0150-05	JUMPER REST 0 OHM		
W32			R92-0150-05	JUMPER REST 0 OHM		
W100			R92-1061-05	JUMPER REST 0OHM		
RL1			S51-1404-05	RELAY (G2E,12V)		
D1			1S1555	DIODE		
D2 ,3		*	US1090	DIODE		
D4			1S2588	DIODE		
D5			BA282	DIODE		
D6			1S2588	DIODE		
D7			BA282	DIODE		
D8			1S2588	DIODE		
D9			BA282	DIODE		
D10			1S2588	DIODE		
D11			BA282	DIODE		
D12			1S2588	DIODE		
D13			BA282	DIODE		
D14			1S2588	DIODE		
D15			BA282	DIODE		
D16			1S2588	DIODE		
D17			BA282	DIODE		
D18			1S2588	DIODE		
D19			BA282	DIODE		
D20			1S2588	DIODE		
D21			BA282	DIODE		
D22			1S2588	DIODE		
D23			BA282	DIODE		
D24			1SS133	DIODE		
D25		*	MA858	DIODE		
D26 -29			BA282	DIODE		

PARTS LIST

* New Parts

Parts without Parts No. are not supplied.

Les articles non mentionnés dans le Parts No. ne sont pas fournis.

Telle ohne Parts No. werden nicht geliefert.

Ref. No. 参照番号	Address 位置	New Parts 新	Parts No. 部品番号	Description 部品名 / 規格	Desti- nation 仕向	Re- marks 備考
D30 -33			1S1587	DIODE		
D34 -37		*	MA858	DIODE		
D38		*	MA858	DIODE		
D39			1SS133	DIODE		
D40			BA282	DIODE		
D41		*	MA858	DIODE		
D42 ,43		*	MA858	DIODE		
D44			ITT310TE	VOLTAGE VARIABLE CAP.		
D45		*	MA858	DIODE		
D46			ITT310TE	VOLTAGE VARIABLE CAP.		
D47		*	MA858	DIODE		
D48			ITT310TE	VOLTAGE VARIABLE CAP.		
D49		*	MA858	DIODE		
D50			ITT310TE	VOLTAGE VARIABLE CAP.		
D51		*	MA858	DIODE		
D52 ,53			1N60	DIODE		
D54			MV13	VARISTOR		
D56 -58			1SS133	DIODE		
D59		*	UZ3.0B	ZENER DIODE		
D67			DAN401	DIODE		
D68		*	US1090	DIODE		
D69		*	DSP-301N	SERGE ABSORBER		
D60 66			1SS133	DIODE		
Q1			2SC2459(BL)	TRANSISTOR		
Q2			2SA562(Y)	TRANSISTOR		
Q3 ,4			2SK125-5	FET		
Q5			3SK74(L)	FET		
Q6 ,7			2SK125-5	FET		
Q8 ,9			2SC2668(Y)	TRANSISTOR		
Q10 ,11			3SK122(L)	FET		
Q12			2SC2668(Y)	TRANSISTOR		
Q13 ,14			3SK122(L)	FET		
Q15			2SC2570A	TRANSISTOR		
Q16			2SC2538	TRANSISTOR		
Q17 -20			DTC143TS	DIGITAL TRANSISTOR		
Q21 -25			2SC2668(Y)	TRANSISTOR		
Q26			2SC1959(Y)	TRANSISTOR		
Q27			2SC2053	TRANSISTOR		
Q28			2SK192A(GR)	FET		
Q29 -31			2SC2668(Y)	TRANSISTOR		
Q32 ,33			2SC2603(E)	TRANSISTOR		
Q34			DTC124ES	DIGITAL TRANSISTOR		
Q35			2SC2603(E)	TRANSISTOR		
Q36			2SC2459(BL)	TRANSISTOR		
Q37			2SC2603(E)	TRANSISTOR		
Q38			UPC4558C	IC(OP AMP X2)		
Q39			2SC2603(E)	TRANSISTOR		
Q40			M74LS145P	IC(DECIMAL DECODER/DRIVER BCD)		
Q40			SN74LS145N	IC(DUAL MONO MULTI)		
Q41			M54561P	IC(7CH LED DRIVER)		
Q45			2SA562(Y)	TRANSISTOR		
Q46			DTC124ES	DIGITAL TRANSISTOR		
FINAL UNIT (X45-1470-00)						
C1			CK45B1H561K	CERAMIC 560PF K		

PARTS LIST

* New Parts

Parts without Parts No. are not supplied.

Les articles non mentionnés dans le Parts No. ne sont pas fournis.

Teile ohne Parts No. werden nicht geliefert.

Ref. No. 参照番号	Address 位置	New Parts 新	Parts No. 部品番号	Description 部品名 / 規格	Desti- nation 仕 向	Re- marks 備考
C2			CK45F1H103Z	CERAMIC 0.010UF Z		
C3			CK45F1H223Z	CERAMIC 0.022UF Z		
C4			CK45B1H102K	CERAMIC 1000PF K		
C5 -7			CK45F1H473Z	CERAMIC 0.047UF Z		
C8 ,9			CK45F1H223Z	CERAMIC 0.022UF Z		
C11			CM93D2H681J	MICA 680PF J		
C12 ,13			C91-1004-05	CERAMIC 0.0068UF J		
C14			CM73F2H122J	CHIP C 1200PF J		
C15			CC45SL2H151J	CERAMIC 150PF J		
C17			CK45F1H473Z	CERAMIC 0.047UF Z		
C18			CE04W1C100M	ELECTRO 10UF 16WV		
C19			CK45F1H223Z	CERAMIC 0.022UF Z		
C20			CE04W1E470M	ELECTRO 47UF 25WV		
C21			CK45F1H223Z	CERAMIC 0.022UF Z		
C22			CK45B1H102K	CERAMIC 1000PF K		
C23			CK45F1H473Z	CERAMIC 0.047UF Z		
C24			CE04W1C100M	ELECTRO 10UF 16WV		
C25			CE04W1E101M	ELECTRO 100UF 25WV		
C26 ,27			CK45F1H473Z	CERAMIC 0.047UF Z		
C28 ,29			CK45F1H103Z	CERAMIC 0.010UF Z		
C31			CK45F1H473Z	CERAMIC 0.047UF Z		
C32			CK45F1H223Z	CERAMIC 0.022UF Z		
C33			CE04W1E470M	ELECTRO 47UF 25WV		
130	2M		E04-0152-05	RF COAXIAL CABLE RECEPTACLE		
132	20		E08-0671-05	RECTANGULAR RECEPTACLE(6P)		
-			E04-0157-05	RF COAXIAL CABLE RECEPTACLE		
MC1			E40-0273-05	PIN CONNECTOR		
136	2M		F09-0410-04	FAN		
-		*	F01-0937-05	HEAT SINK		
-			F20-0078-05	INSULATING BOARD		
-			F29-0014-05	INSULATOR		
142	2M		G02-0549-04	FLAT SPRING		
145	2N		J21-4153-14	FAN MOUNTING HARDWARE		
-			L92-0102-05	TRIADAL CORE (FOR L6,7,11)		
-			L92-0106-05	TRIADAL CORE (FOR T1)		
-			L92-0106-05	TRIADAL CORE (FOR L13)		
L1			L40-1511-13	SMALL FIXED INDUCTOR		
L2 ,3			L33-0651-05	CHOKE COIL		
L4 ,5			L33-0232-05	CHOKE COIL (1UH)		
L6 ,7			L33-0617-05	CHOKE COIL		
L8 -10			L33-0651-05	CHOKE COIL		
L11			L33-0617-05	CHOKE COIL		
L12			L40-1011-13	SMALL FIXED INDUCTOR		
L13		*	L39-0424-05	COIL		
T1			L19-0340-05	BALUN TRANSFORMER		
T2			F19-0338-05	INPUT TRANSFORMER		
T3			L19-0342-05	DRIVE TRANSFORMER		
T4		*	L19-0363-05	FINAL TRANSFORMER		
150	1N		N14-0115-05	NUT		
151	1N		N14-0509-05	NUT		
152	1N		N15-1040-46	FLAT WASHER		
A	2M, 1N		N89-3006-46	BINDING HEAD TAPTITE SCREW		
AA	10		N09-0256-05	SCREW (GND)		

PARTS LIST

× New Parts

Parts without Parts No. are not supplied.

Les articles non mentionnés dans le Parts No. ne sont pas fournis.

Teile ohne Parts No. werden nicht geliefert.

Ref. No. 参照番号	Address 位置	New Parts 新	Parts No. 部品番号	Description 部品名 / 規格	Desti- nation 仕向	Re- marks 備考
CC	2M		N09-0658-04	SCREW		
VV	20		N09-0372-04	SCREW (PULLEY)		
WW	1M		N09-0682-04	SCREW		
Y	1N, 2N		N30-3008-46	PAN HEAD MACHINE SCREW		
Z	20		N30-4005-46	PAN HEAD MACHINE SCREW		
R3			RC05GF2H3R9J	RC 3.9 J 1/2W		
R9 ,10			RC05GF2H181J	RC 180 J 1/2W		
R11 -14			RS14AB3ASR6J	FL-PR0NF RS 5.6 J 1W		
R15 ,16			RC05GF2H150J	RC 15 J 1/2W		
R17 ,18			RS14AB3ASR6J	FL-PR0NF RS 5.6 J 1W		
R33			RC05GF2H100J	RC 10 J 1/2W		
VR1 ,2			R12-1406-05	TRIMMING P0T. (BACK CURRENT)		
WB			R92-0150-05	JUMPER REST 0 5HM		
155	2N		T42-0302-05	DC MOTOR ASSY		
D1			MV-ST	VARISTOR		
D2 ,3		*	SV03YS	VARISTOR		
D4			1S8133	DIODE		
D4			1S1555	DIODE		
Q1			2SC2075	TRANSISTOR		
Q2 ,3			2SC2509	TRANSISTOR		
Q4 ,5		*	2SC2879	TRANSISTOR		
Q6 ,7			2SD1406(Y)	TRANSISTOR		
Q8			2SC1815(Y)	TRANSISTOR		
Q9			AN6551	IC(OP AMP X2)		
TH1			SDT1000	THERMISTOR		
TH1		*	5T41L	THERMISTOR		
PLL UNIT (X50-2050-00)						
C1			C092M1H223K	MYLAR 0.022UF K		
C2			C91-0117-05	CERAMIC 0.01UF K		
C3			C91-0119-05	CERAMIC 0.047UF K		
C4			C092M1H223K	MYLAR 0.022UF K		
C5			CK45B1H182K	CERAMIC 1800PF K		
C6			C91-0119-05	CERAMIC 0.047UF K		
C7			CE04W1A470M	ELECTRO 47UF 10WV		
C8			CC45RH1H180J	CERAMIC 18PF J		
C9			CC45CH1H100D	CERAMIC 10PF D		
C10			CC45CH1H220J	CERAMIC 22PF J		
C11			CC45CH1H330J	CERAMIC 33PF J		
C12			C91-0117-05	CERAMIC 0.01UF K		
C13			CE04W1A470M	ELECTRO 47UF 10WV		
C14			CC45CH1H050C	CERAMIC 5.0PF C		
C15			C91-0769-05	CERAMIC 0.01UF M		
C16			CC45SL1H050C	CERAMIC 5.0PF C		
C17			CC45SL1H100D	CERAMIC 10PF D		
C18			C91-0117-05	CERAMIC 0.01UF K		
C19			C91-0119-05	CERAMIC 0.047UF K		
C20			C91-0769-05	CERAMIC 0.01UF M		
C21			CE04W1C220M	ELECTRO 22UF 16WV		
C22 ,23			C91-1008-05	CERAMIC 0.022UF K		
C24			C91-0769-05	CERAMIC 0.01UF M		
C25			C91-1008-05	CERAMIC 0.022UF K		
C26			CK45B1H391K	CERAMIC 390PF K		
C27			CK45B1H821K	CERAMIC 820PF K		

PARTS LIST

* New Parts

Parts without Parts No. are not supplied.

Les articles non mentionnés dans le Parts No. ne sont pas fournis.

Teile ohne Parts No. werden nicht geliefert.

Ref. No. 参照番号	Address 位置	New Parts 新	Parts No. 部品番号	Description 部品名 / 規格	Desti- nation 仕向	Re- marks 備考
C28			CK45B1H391K	CERAMIC 390PF K		
C29			C91-0769-05	CERAMIC 0.01UF M		
C30			C91-0119-05	CERAMIC 0.047UF K		
C31 ,32			C91-0117-05	CERAMIC 0.01UF K		
C33			CC45SL1H390J	CERAMIC 39PF J		
C34			CC45SL1H820J	CERAMIC 82PF J		
C35			CC45SL1H390J	CERAMIC 39PF J		
C36			C91-0117-05	CERAMIC 0.01UF K		
C37			C91-1008-05	CERAMIC 0.022UF K		
C38 ,39			C91-0117-05	CERAMIC 0.01UF K		
C40 ,41			CC92M1H223K	MYLAR 0.022UF K		
C42			C91-0119-05	CERAMIC 0.047UF K		
C43			CK45B1H182K	CERAMIC 1800PF K		
C44			C91-0119-05	CERAMIC 0.047UF K		
C45			CE04W1A470M	ELECTRO 47UF 10WV		
C46			CC45UJ1H220J	CERAMIC 22PF J		
C47			CC45CH1H100D	CERAMIC 10PF D		
C48			CC45CH1H120J	CERAMIC 12PF J		
C49			CC45CH1H220J	CERAMIC 22PF J		
C50			CC45SL1H050C	CERAMIC 5.0PF C		
C51			C91-0117-05	CERAMIC 0.01UF K		
C52			CE04W1A470M	ELECTRO 47UF 10WV		
C53			C91-0769-05	CERAMIC 0.01UF M		
C54			CC45SL1H050C	CERAMIC 5.0PF C		
C55			CC45SL1H100D	CERAMIC 10PF D		
C56			C91-0117-05	CERAMIC 0.01UF K		
C57			C91-0117-05	CERAMIC 0.01UF K		
C58			C91-0119-05	CERAMIC 0.047UF K		
C59			C91-1008-05	CERAMIC 0.022UF K		
C60			C91-0117-05	CERAMIC 0.01UF K		
C61			CC45SL1H820J	CERAMIC 82PF J		
C62			CC45SL1H181J	CERAMIC 180PF J		
C63			CC45SL1H820J	CERAMIC 82PF J		
C64			C91-0117-05	CERAMIC 0.01UF K		
C65 -67			C91-1008-05	CERAMIC 0.022UF K		
C68			C91-0117-05	CERAMIC 0.01UF K		
C69			C91-1008-05	CERAMIC 0.022UF K		
C70 ,71			C91-0769-05	CERAMIC 0.01UF M		
C72 -75			C91-0117-05	CERAMIC 0.01UF K		
C76			C91-0769-05	CERAMIC 0.01UF M		
C77 ,78			C91-0117-05	CERAMIC 0.01UF K		
C79 ,80			C91-0769-05	CERAMIC 0.01UF M		
C81			C91-0119-05	CERAMIC 0.047UF K		
C82			C91-0117-05	CERAMIC 0.01UF K		
C83			CC92M1H223K	MYLAR 0.022UF K		
C84			CC92M1H333K	MYLAR 0.033UF K		
C85			CK45B1H182K	CERAMIC 1800PF K		
C86			C91-0119-05	CERAMIC 0.047UF K		
C87			CE04W1A470M	ELECTRO 47UF 10WV		
C88			CC45UJ1H330J	CERAMIC 33PF J		
C89			CC45CH1H100D	CERAMIC 10PF D		
C90 ,91			CC45CH1H220J	CERAMIC 22PF J		
C92			CC45CH1H050C	CERAMIC 0.5PF C		
C93			C91-0117-05	CERAMIC 0.01UF K		
C94			CE04W1A470M	ELECTRO 47UF 10WV		

PARTS LIST

※ New Parts

Parts without Parts No. are not supplied.

Les articles non mentionnés dans le Parts No. ne sont pas fournis.

Teile ohne Parts No. werden nicht geliefert.

Ref. No. 参照番号	Address 位置	New Parts 新	Parts No. 部品番号	Description 部品名 / 規格	Desti- nation 仕 向	Re- marks 備考
C95			C91-0117-05	CERAMIC 0.01UF K		
C96 ,97			CC45SL1H100D	CERAMIC 10PF D		
C98			C91-0117-05	CERAMIC 0.01UF K		
C99			C91-0769-05	CERAMIC 0.01UF M		
C100			C91-0119-05	CERAMIC 0.047UF K		
C101,102			C91-0117-05	CERAMIC 0.01UF K		
C104			CC45SL1H680J	CERAMIC 68PF J		
C106			C91-0769-05	CERAMIC 0.01UF M		
C108			CC45CH1H100D	CERAMIC 10PF D		
C109			C91-0769-05	CERAMIC 0.01UF M		
C110			CC45UJ1H180J	CERAMIC 18PF J		
C111			CC45CH1H560J	CERAMIC 56PF J		
C112			CC45CH1HOR5C	CERAMIC 0.5PF C		
C113			CE04W1C220M	ELECTRO 22UF 16WV		
C114			CC45SL1H050C	CERAMIC 5.0PF C		
C115			CC45SL1H100D	CERAMIC 10PF D		
C116			C91-0769-05	CERAMIC 0.01UF M		
C117-121			C91-0117-05	CERAMIC 0.01UF K		
C122			CC45SL1H101J	CERAMIC 100PF J		
C123-128			C91-0117-05	CERAMIC 0.01UF K		
C129			CC45SL1H100D	CERAMIC 10PF D		
C130			C91-0117-05	CERAMIC 0.01UF K		
C131			C91-1008-05	CERAMIC 0.022UF K		
C132			CK45B1H102K	CERAMIC 1000PF K		
C133,134			C91-0119-05	CERAMIC 0.047UF K		
C135			CK45B1H102K	CERAMIC 1000PF K		
C136,137			C91-0769-05	CERAMIC 0.01UF M		
C138-141			C91-0117-05	CERAMIC 0.01UF K		
C142			C91-0769-05	CERAMIC 0.01UF M		
C143			C91-0117-05	CERAMIC 0.01UF K		
C144			CK45B1H102K	CERAMIC 1000PF K		
C146-148			CC45SL1H101J	CERAMIC 100PF J		
C149			C91-0769-05	CERAMIC 0.01UF M		
C150			CC45RH1H070D	CERAMIC 7.0PF D		
C151			CC45RH1H100D	CERAMIC 10PF D		
C152			CC45RH1H050C	CERAMIC 5.0PF C		
C153			CC45RH1H100D	CERAMIC 10PF D		
C154,155			CC45RH1H080D	CERAMIC 8.0PF D		
C156			CC45SL1H680J	CERAMIC 68PF J		
C157			C91-0769-05	CERAMIC 0.01UF M		
C158			C91-0119-05	CERAMIC 0.047UF K		
C159,160			C91-0117-05	CERAMIC 0.01UF K		
C161-163			C91-0119-05	CERAMIC 0.047UF K		
C165			CS15E1VR33M	TANTAL 0.33UF 35WV		
C166			C91-0119-05	CERAMIC 0.047UF K		
C167			CE04W1A101M	ELECTRO 100UF 10WV		
C168			CK45B1H102K	CERAMIC 1000PF K		
C169			C91-0119-05	CERAMIC 0.047UF K		
C170			CC45CH1HOR5C	CERAMIC 0.5PF C		
C171			C91-0117-05	CERAMIC 0.01UF K		
C172			C91-0769-05	CERAMIC 0.01UF M		
C173			C91-0119-05	CERAMIC 0.047UF K		
C175			C91-0119-05	CERAMIC 0.047UF K		
C176			C91-0117-05	CERAMIC 0.01UF K		
C177			CO92M1H333K	MYLAR 0.033UF K		

PARTS LIST

× New Parts

Parts without Parts No. are not supplied.

Les articles non mentionnes dans le Parts No. ne sont pas fournis.

Teile ohne Parts No. werden nicht geliefert.

Ref. No. 参照番号	Address 位置	New Parts 新	Parts No. 部品番号	Description 部品名 / 規格	Desti- nation 仕向	Re- marks 備考
C178			CS15E1VR1M	TANTAL 0.1UF 35WV		
C179			CK45B1H182K	CERAMIC 1800PF K		
C180			CE04W1H100M	ELECTR0 10UF 50WV		
C181			C91-0117-05	CERAMIC 0.01UF K		
C182			CS15E1VR47M	TANTAL 0.47UF 35WV		
C183			CC45RH1H070D	CERAMIC 7.0PF D		
C184			C91-0119-05	CERAMIC 0.047UF K		
C185			CE04W1A470M	ELECTR0 47UF 10WV		
C186			C91-0117-05	CERAMIC 0.01UF K		
C187			CC45RH1H060D	CERAMIC 6.0PF D		
C188			CC45CH1H100D	CERAMIC 10PF D		
C189			CC45CH1H220J	CERAMIC 22PF J		
C190			CC45CH1H220J	CERAMIC 22PF J		
C191			CE04W1A470M	ELECTR0 47UF 10WV		
C192			C91-0117-05	CERAMIC 0.01UF K		
C193			CC45CH1H010C	CERAMIC 1.0PF C		
C194			C91-0769-05	CERAMIC 0.01UF M		
C195			CC45SL1H050C	CERAMIC 5.0PF C		
C196			CC45SL1H101J	CERAMIC 100PF J		
C197			C91-0117-05	CERAMIC 0.01UF K		
C198			CK45B1H182K	CERAMIC 1800PF K		
C199		*	CC45CH1H090D	CERAMIC 9.0PF D		
C200,201			CC45SL1H560J	CERAMIC 56PF J		
C202,203			C91-0117-05	CERAMIC 0.01UF K		
C204			CC45SL1H221J	CERAMIC 220PF J		
C205			CC45CH1H100D	CERAMIC 10PF D		
C206			C91-0119-05	CERAMIC 0.047UF K		
TC1			C05-0035-05	TRIMMING CAP (50PF)		
-			E40-0273-05	PIN CONNECTOR (MINI,2P)		
-			E40-0274-05	PIN CONNECTOR (MINI,2P)		
-			E40-0473-05	PIN CONNECTOR (MINI,4P)		
-			E40-0573-05	PIN CONNECTOR (MINI,5P)		
-			E40-0973-05	PIN CONNECTOR (MINI,9P)		
L1 ,2		*	L40-1011-13	SMALL FIXED INDUCTOR		
L3			L40-2211-14	SMALL FIXED INDUCTOR		
L4 -6		*	L40-1011-14	SMALL FIXED INDUCTOR		
L7 ,8		*	L40-3311-14	SMALL FIXED INDUCTOR		
L9		*	L40-1011-14	SMALL FIXED INDUCTOR		
L10 ,11			L40-3301-14	SMALL FIXED INDUCTOR		
L12 ,13		*	L40-1011-13	SMALL FIXED INDUCTOR		
L14			L40-2211-14	SMALL FIXED INDUCTOR		
L15 ,16		*	L40-1011-14	SMALL FIXED INDUCTOR		
L17		*	L40-1011-13	SMALL FIXED INDUCTOR		
L18 ,19			L40-6801-14	SMALL FIXED INDUCTOR		
L20 ,21		*	L40-1011-13	SMALL FIXED INDUCTOR		
L22			L40-2211-14	SMALL FIXED INDUCTOR		
L23 ,24		*	L40-1011-14	SMALL FIXED INDUCTOR		
L25 ,26			L40-2201-14	SMALL FIXED INDUCTOR		
L27		*	L40-1011-14	SMALL FIXED INDUCTOR		
L28		*	L40-1011-13	SMALL FIXED INDUCTOR		
L29		*	L40-1001-14	SMALL FIXED INDUCTOR		
L30 -32			L40-4701-14	SMALL FIXED INDUCTOR		
L33 ,34		*	L40-1011-14	SMALL FIXED INDUCTOR		
L35 ,36		*	L40-1011-13	SMALL FIXED INDUCTOR		

PARTS LIST

* New Parts

Parts without Parts No. are not supplied.

Les articles non mentionnés dans le Parts No. ne sont pas fournis.

Teile ohne Parts No. werden nicht geliefert.

Ref. No. 参照番号	Address 位 置	New Parts 新	Parts No. 部 品 番 号	Description 部 品 名 / 規 格	Desti- nation 仕 向	Re- marks 備 考
L37 ,38			L40-2211-14	SMALL FIXED INDUCTOR		
L39		*	L40-1011-13	SMALL FIXED INDUCTOR		
L40		*	L40-2201-13	SMALL FIXED INDUCTOR		
L41		*	L40-1001-14	SMALL FIXED INDUCTOR		
L42		*	L40-1011-13	SMALL FIXED INDUCTOR		
L43			L40-2211-14	SMALL FIXED INDUCTOR		
L44		*	L40-1001-14	SMALL FIXED INDUCTOR		
L46		*	L40-1011-13	SMALL FIXED INDUCTOR		
L47		*	L40-1011-14	SMALL FIXED INDUCTOR		
T1 ,2		*	L32-0666-15	OSCILLATING COIL (VCO, 95MHZ)		
T3		*	L34-2269-05	COIL (6.6MHZ, BPF)		
T4		*	L34-2270-05	COIL (6.6MHZ, BPF)		
T5		*	L34-2269-05	COIL (6.6MHZ, BPF)		
T6		*	L34-2271-05	COIL (62MHZ, BPF)		
T7		*	L34-2272-15	COIL (62MHZ, BPF)		
T8		*	L34-2292-05	COIL (62MHZ, BPF)		
T9			L32-0639-05	OSCILLATING COIL (VCO, 55MHZ)		
T10		*	L34-2273-05	COIL (30MHZ, BPF)		
T11		*	L34-2274-05	COIL (30MHZ, BPF)		
T12		*	L34-2273-05	COIL (30MHZ, BPF)		
T13		*	L34-2275-05	COIL (39MHZ, BPF)		
T14		*	L34-2276-05	COIL (39MHZ, BPF)		
T15		*	L34-2275-05	COIL (39MHZ, BPF)		
T16			L34-0851-05	COIL (40MHZ, LPF)		
T17 ,18			L34-0856-05	COIL (40MHZ, LPF)		
T19			L34-0851-05	COIL (40MHZ, LPF)		
T20			L32-0677-15	OSCILLATING COIL (VCO, 36MHZ)		
T45			L34-1124-05	COIL		
X1		*	L77-1299-05	CRYSTAL RESONATOR		
IR1		*	R90-0596-05	MULTI-COMP (100PF X8)		
VR1 ,2			R12-4413-05	TRIMMING PNT. (VCO2, ETC.)		
WB			R92-0150-05	JUMPER REST 0 OHM		
W18			R92-0150-05	JUMPER REST 0 OHM		
W20			R92-0150-05	JUMPER REST 0 OHM		
W21			R92-1061-05	JUMPER REST 0OHM		
W35			R92-0150-05	JUMPER REST 0 OHM		
W45 ,46			R92-0150-05	JUMPER REST 0 OHM		
W49 -51			R92-0150-05	JUMPER REST 0 OHM		
D1 ,2			1SS133	DIODE		
D3			1SV53A	DIODE		
D4 ,5			1SS133	DIODE		
D6			1TT310TE	VARI CAP		
D7 ,8			1SS133	DIODE		
D9			1TT310TE	VARI CAP		
D10			1SS133	DIODE		
D11			MV13	VARIABLE		
D12			1SS133	DIODE		
D13			MV203	VARIABLE		
D14		*	1SV153	DIODE		
IC1			MN6147	IC		
IC1			MN6147C	IC (FREQ SYNTHESIZER PLL)		
IC2			MS4459L	IC (PRE SCALER)		
IC3			SN74LS90N	IC		
IC4			MN6147	IC		

PARTS LIST

* New Parts

Parts without Parts No. are not supplied.

Les articles non mentionnés dans le Parts No. ne sont pas fournis.

Teile ohne Parts No. werden nicht geliefert.

Ref. No. 参照番号	Address 位置	New Parts 新	Parts No. 部品番号	Description 部品名/規格	Desti- nation 仕向	Re- marks 備考
IC4			MN6147C	IC(FREQ SYNTHESIZER PLL)		
IC5		*	M54460L	IC(PRE SCALER)		
IC6			SN74LS90N	IC		
IC7 ,8			SN16913P	IC(DUBLE BALANCED MIXERS)		
IC9			MN6147	IC		
IC10		*	M54460L	IC(PRE SCALER)		
IC11,12			SN16913P	IC(DUBLE BALANCED MIXERS)		
IC13			SN74S112N	IC		
IC14			SN16913P	IC(DUBLE BALANCED MIXERS)		
IC15			SN74S10N	IC		
IC16			SN74S112N	IC		
IC17		*	MB87006	IC(FREQ SYNTHESIZER PLL)		
IC18			MN6147	IC		
Q1 ,2			2SC3113(B)	TRANSISTOR		
Q3 -5			2SC2668(Y)	TRANSISTOR		
Q6 ,7			2SC2458(Y)	TRANSISTOR		
Q8			2SC1959(Y)	TRANSISTOR		
Q9			2SC2458(Y)	TRANSISTOR		
Q10 ,11			2SC3113(B)	TRANSISTOR		
Q12 -15			2SC2668(Y)	TRANSISTOR		
Q16 ,17			2SC3113(B)	TRANSISTOR		
Q18 -20			2SC2668(Y)	TRANSISTOR		
Q21			2SC2787(L)	TRANSISTOR		
Q22 -24			2SC2668(Y)	TRANSISTOR		
Q25			2SC2458(Y)	VARICAP		
Q26 -30			2SC2668(Y)	TRANSISTOR		
Q31 -35			2SC2459(BL)	TRANSISTOR		
Q36			2SK192A(GR)+J	FET		
Q37			2SC2668(Y)	TRANSISTOR		
FILTER UNIT (X51-1340-00)						
C1 ,2			CC45CH1H101J	CERAMIC 100PF J		
C3 -6			CK45B1H222K	CERAMIC 2200PF K		
C7 ,8			CK45F1H473Z	CERAMIC 0.047UF Z		
C9 ,10			CK45B1H222K	CERAMIC 2200PF K		
C11			CK45F1H473Z	CERAMIC 0.047UF Z		
C12			CK45F1H103Z	CERAMIC 0.010UF Z		
C13			CE04W1H010M	ELECTRO 1.0UF 50WV		
C14			CE04W1HR47M	ELECTRO 0.47UF 50WV		
C15			CE04W1H100M	ELECTRO 10UF 50WV		
C16			CK45F1H103Z	CERAMIC 0.010UF Z		
C18			C91-0117-05	CERAMIC 0.01UF K		
C20			C91-0117-05	CERAMIC 0.047UF K		
C21			C91-0117-05	CERAMIC 0.01UF K		
C23			CK45F1H103Z	CERAMIC 0.010UF Z		
C24			CK45F1H223Z	CERAMIC 0.022UF Z		
C25			CK45F1H103Z	CERAMIC 0.010UF Z		
C26			CK45F1H473Z	CERAMIC 0.047UF Z		
C27			CK45F1H103Z	CERAMIC 0.010UF Z		
C28			CE04W1HR47M	ELECTRO 0.47UF 50WV		
C29			C91-0117-05	CERAMIC 0.01UF K		
C30			CE04W1H3R3M	ELECTRO 3.3UF 50WV		
C31			C91-0117-05	CERAMIC 0.01UF K		
C32 -44			CK45F1H473Z	CERAMIC 0.047UF Z		
C45			CE04W1H100M	ELECTRO 10UF 50WV		
C46			CK45F1H103Z	CERAMIC 0.010UF Z		

PARTS LIST

* New Parts

Parts without Parts No. are not supplied.

Les articles non mentionnes dans le Parts No. ne sont pas fournis.

Teile ohne Parts No. werden nicht geliefert.

Ref. No. 参照番号	Address 位置	New Parts 新	Parts No. 部品番号	Description 部品名 / 規格	Desti- nation 仕向	Re- marks 備考
C47			CK45F1H223Z	CERAMIC 0.022UF Z		
C51			CM93D2H152J	MICA 1500PF J		
C52			CM93D2H471J	MICA 470PF J		
C53			CM93D2H152J	MICA 1500PF J		
C54			CM93D2H221J	MICA 220PF J		
C55			CM93D2H821J	MICA 820PF J		
C56		*	CC45SL2H431J	CERAMIC 430PF J		
C57		*	CC45SL2H241J	CERAMIC 240PF J		
C58 , 59		*	CC45SL2H431J	CERAMIC 430PF J		
C60			CC45SL2H151J	CERAMIC 150PF J		
C61		*	CC45SL2H331J	CERAMIC 330PF J		
C62			CC45SL2H820J	CERAMIC 82PF J		
C63		*	CC45SL2H331J	CERAMIC 330PF J		
C64			CC45SL2H101J	CERAMIC 100PF J		
C65		*	CC45SL2H431J	CERAMIC 430PF J		
C66		*	CC45SL2H331J	CERAMIC 330PF J		
C67			CC45SL2H151J	CERAMIC 150PF J		
C68			CC45SL2H330J	CERAMIC 33PF J		
C69			CC45SL2H151J	CERAMIC 150PF J		
C70			CC45SL2H121J	CERAMIC 120PF J		
C71			CC45SL2H181J	CERAMIC 180PF J		
C72			CC45SL2H820J	CERAMIC 82PF J		
C73			CC45SL2H680J	CERAMIC 68PF J		
C74			CC45SL2H181J	CERAMIC 180PF J		
C75			CC45SL2H121J	CERAMIC 120PF J		
C76			CC45SL2H101J	CERAMIC 100PF J		
C77			CC45SL2H470J	CERAMIC 47PF J		
C78			CC45SL2H680J	CERAMIC 68PF J		
C79			CC45SL2H330J	CERAMIC 33PF J		
C80			CC45SL2H820J	CERAMIC 82PF J		
C81			CC45SL2H680J	CERAMIC 68PF J		
C82			CC45SL2H820J	CERAMIC 82PF J		
C83			CC45SL2H151J	CERAMIC 150PF J		
C84			C91-0119-05	CERAMIC 0.047UF K		
C86			C91-0119-05	CERAMIC 0.047UF K		
C87			CC45SL2H100D	CERAMIC 10PF D		
-			E04-0157-05	RF COAXIAL CABLE RECEPTACLE		
-			E40-0473-05	PIN CONNECTOR (MINI,4P)		
-			E40-0573-05	PIN CONNECTOR (MINI,5P)		
-			E40-0673-05	PIN CONNECTOR (MINI,6P)		
-			E40-0773-05	PIN CONNECTOR (MINI,7P)		
-			E40-1273-05	PIN CONNECTOR (MINI,12P)		
-			L92-0106-05	BEAD CORE (FOR L42,43)		
-		*	L92-0107-05	BEAD CORE (FOR L30-35)		
-		*	L92-0108-05	BEAD CORE (FOR L36,37)		
L1 -22			L40-1011-14	SMALL FIXED INDUCTOR		
L30		*	L34-3148-05	COIL		
L31		*	L34-3147-05	COIL		
L32		*	L34-3150-05	COIL		
L33		*	L34-3149-05	COIL		
L34		*	L34-3152-05	COIL		
L35		*	L34-3151-05	COIL		
L36		*	L34-3153-05	COIL		

PARTS LIST

* New Parts

Parts without Parts No. are not supplied.

Les articles non mentionnes dans le Parts No. ne sont pas fournis.

Teile ohne Parts No. werden nicht geliefert.

Ref. No. 参照番号	Address 位置	New Parts 新	Parts No. 部品番号	Description 部品名 / 規格	Desti- nation 仕向	Re- marks 備考
L37		*	L34-3154-05	COIL		
L38		*	L34-3156-05	COIL		
L40		*	L34-3157-05	COIL		
L41		*	L34-3158-05	COIL		
L42		*	L39-0422-05	COIL		
L43		*	L39-0423-05	COIL		
R1			RC05GF2H181J	RC 180 J 1/2W		
R2 -4			RC05GF2H101J	RC 100 J 1/2W		
VR1 .2			R12-4414-05	TRIMMING PBT. (50K) PROTECTION		
VR3			R12-3447-05	TRIMMING PBT. (10K) POWER DOWN		
VR4 -6			R12-1431-05	TRIMMING PBT. (1K) ALC METER		
W13			R92-1061-05	JUMPER REST 00HM		
W14			R92-0150-05	JUMPER REST 0 8HM		
RL1 -12			S51-1420-05	RELAY (DC-1, 12V)		
S1			S31-1411-05	SLIDE SWITCH		
D1			1S1587	DIODE		
D2			1S1007	DIODE		
D3 -5			1SS101	DIODE		
D4			MTZ9. 1JC	ZENER DIODE		
D6		*	UZ9. 1BL	ZENER DIODE		
D7			MTZ7. 5JA	ZENER DIODE		
D8			MTZ9. 1JC	ZENER DIODE		
D8		*	UZ9. 1BL	ZENER DIODE		
D9			MTZ4. 3JC	ZENER DIODE		
D10			MTZ3. 0JB	ZENER DIODE		
D12 -23			1N4448	DIODE		
D12 -23			1S1555	DIODE		
D23			MC931	DIODE		
D25			MTZ7. 5JA	ZENER DIODE		
Q1			DTC114ES	DIGITAL TRANSISTOR		
Q2			2SC1815(Y)	TRANSISTOR		
Q3			2SC3113(B)	TRANSISTOR		
Q4			DTC114ES	DIGITAL TRANSISTOR		
Q5			BA718	IC(OP AMP X2)		
Q6			DTC114ES	DIGITAL TRANSISTOR		
CONTROL UNIT (X53-1450-11)						
C1 .2			CC45CH1H270J	CERAMIC 27PF J		
C3			C91-0119-05	CERAMIC 0. 047UF K		
C4			C90-0822-05	ELECTRO 47UF 16WV		
C5			C91-0769-05	CERAMIC 0. 01UF M		
C6			C91-0119-05	CERAMIC 0. 047UF K		
C7			C90-0822-05	ELECTRO 47UF 16WV		
C8			C91-0119-05	CERAMIC 0. 047UF K		
C9			C91-0769-05	CERAMIC 0. 01UF M		
C10			C90-0484-05	ELECTRO 0. 47UF 50WV		
C11			C90-0822-05	ELECTRO 47UF 16WV		
C12			C91-0757-05	CERAMIC 0. 001UF K		
C13			C91-0769-05	CERAMIC 0. 01UF M		
C14			C90-0822-05	ELECTRO 47UF 16WV		
C15 .16			CC45SL 1H101J	CERAMIC 100PF J		
C17 .18			C91-0757-05	CERAMIC 0. 001UF K		
C19			C092M1H472K	MYLAR 4700PF K		
C20 .21			C91-0769-05	CERAMIC 0. 01UF M		

PARTS LIST

× New Parts

Parts without Parts No. are not supplied.

Les articles non mentionnés dans le Parts No. ne sont pas fournis.

Teile ohne Parts No. werden nicht geliefert.

Ref. No. 参照番号	Address 位置	New Parts 新	Parts No. 部品番号	Description 部品名 / 規格	Desti- nation 仕向	Re- marks 備考
C22			C90-0822-05	ELECTRO 47UF 16WV		
C23 -38			C91-0769-05	CERAMIC 0.01UF M		
C39 -41			C91-0753-05	CERAMIC 470PF K		
C45 -48			C91-0769-05	CERAMIC 0.01UF M		
C50			C91-0119-05	CERAMIC 0.047UF K		
C51		*	C90-2020-05	ELECTRO 15UF 25WV		
C52			C91-0769-05	CERAMIC 0.01UF M		
C53 ,54			C91-0119-05	CERAMIC 0.047UF K		
C55			C90-0822-05	ELECTRO 47UF 16WV		
C56			C91-0119-05	CERAMIC 0.047UF K		
C57			C90-0822-05	ELECTRO 47UF 16WV		
C58			C91-0119-05	CERAMIC 0.047UF K		
C59			C90-0822-05	ELECTRO 47UF 16WV		
C60			C91-0769-05	CERAMIC 0.01UF M		
C61			C91-0119-05	CERAMIC 0.047UF K		
C62			C90-0822-05	ELECTRO 47UF 16WV		
C63 ,64			C91-0757-05	CERAMIC 0.001UF K		
C65 -70			C91-0769-05	CERAMIC 0.01UF M		
C100-114			C91-0769-05	CERAMIC 0.01UF M		
-		*	E02-0114-05	TRANSISTOR SOCKET (16P)		
-			E02-2001-05	TRANSISTOR SOCKET (28P)		
-			E40-3237-05	PIN CONNECTOR (MINI,2P)		
-			E40-3238-05	PIN CONNECTOR (MINI,3P)		
-			E40-3239-05	PIN CONNECTOR (MINI,4P)		
-			E40-3240-05	PIN CONNECTOR (MINI,5P)		
-			E40-3241-05	PIN CONNECTOR (MINI,6P)		
-			E40-3242-05	PIN CONNECTOR (MINI,7P)		
-			E40-3243-05	PIN CONNECTOR (MINI,8P)		
-			E40-5066-05	PIN CONNECTOR (MINI,9P)		
L1			L40-1011-13	SMALL FIXED INDUCTOR		
L3 ,4			L40-1011-14	SMALL FIXED INDUCTOR		
L5			L40-1011-03	SMALL FIXED INDUCTOR		
L6 -19			L40-1011-14	SMALL FIXED INDUCTOR		
L23			L40-1011-14	SMALL FIXED INDUCTOR		
L50 ,51			L40-1011-14	SMALL FIXED INDUCTOR		
L52			L40-1011-13	SMALL FIXED INDUCTOR		
L53 -55			L40-1011-03	SMALL FIXED INDUCTOR		
L58 ,59			L40-4701-14	SMALL FIXED INDUCTOR		
X1		*	L78-0019-05	RESONATOR (1.99MHZ)		
X50			L78-0015-05	RESONATOR (2.45MHZ)		
RB1			R90-0510-05	MULTI-COMP (4.7KX8)		
RB50			R90-0510-05	MULTI-COMP (4.7KX8)		
RF51			R90-0521-05	MULTI-COMP (47KX7)		
RB52			R90-0597-05	MULTI-COMP (1KX4)		
W1 -3			R92-1061-05	JUMPER REST 08HM		
W50			R92-1061-05	JUMPER REST 08HM		
S50		*	S31-0402-05	SLIDE SWITCH		
D1 ,2			1SS133	DIODE		
D5 -9			1SS133	DIODE		
D51 -71			1SS133	DIODE		
D73			1SS133	DIODE		
D75			1SS133	DIODE		

PARTS LIST

× New Parts

Parts without Parts No. are not supplied.

Les articles non mentionnés dans le Parts No. ne sont pas fournis.

Telle ohne Parts No. werden nicht geliefert.

Ref. No. 参照番号	Address 位置	New Parts 新	Parts No. 部品番号	Description 部品名 / 規格	Desti- nation 仕向	Re- marks 備考
D81 D82 -84 IC1 IC2 IC2			1SS101 1SS133 UPD7800G TMP8255AP-5 UPD8255AC-5	DIODE DIODE IC (MICROPROCESSOR) IC (PROGRAMMABLE INTERFACE) IC (PROGRAMMABLE INTERFACE)		
IC3 IC4 IC5 IC6 IC7		*	PST520D TC4069UBP TC4011BP TC4030BP TC4011BP	IC (LOW POWER RESET) IC (INVERTER X6) IC (NAND X4) IC (EXCLUSIVE OR X4) IC (NAND X4)		
IC20 IC51 IC52 IC53 IC53		*	MB8418-20LP-GRA SN74LS138N MBM27128-25JA1 TMP8255AP-5 UPD8255AC-5	IC (16K RAM) IC IC (PROGRAMMABLE INTERFACE) IC (PROGRAMMABLE INTERFACE) IC (PROGRAMMABLE INTERFACE)		
IC56 Q1 -7 Q8 -13 Q14 Q18 -24		*	SN7404N DTC144WS DTA114ES DTC144WS DTA114ES	IC (6-CIRCUIT INVERTER) DIGITAL TRANSISTOR DIGITAL TRANSISTOR DIGITAL TRANSISTOR DIGITAL TRANSISTOR		
Q25 Q50			DTA114ES DTC144WS	DIGITAL TRANSISTOR DIGITAL TRANSISTOR		
DISPLAY UNIT (X54-1870-00)						
C1 C2 C3 C4 C5 -7		*	C90-0871-05 C91-0119-05 C90-0504-05 C892M1H223K C90-0504-05	ELECTRO 220UF 16WV CERAMIC 0.047UF K ELECTRO 10UF 35WV MYLAR 0.022UF K ELECTRO 10UF 35WV		
C10 C11 C12 -14 C15 C16		*	C91-0769-05 C90-0822-05 C91-0769-05 C90-0822-05 C91-0769-05	CERAMIC 0.01UF M ELECTRO 47UF 16WV CERAMIC 0.01UF M ELECTRO 47UF 16WV CERAMIC 0.01UF M		
C17 C50 -52 C53 C54 -56 C57		*	C91-0119-05 CK45F1H103Z CK45E2H222P CK45B1H102K CK45F1H103Z	CERAMIC 0.047UF K CERAMIC 0.010UF Z CERAMIC 2200PF P CERAMIC 1000PF K CERAMIC 0.010UF Z		
- - - - -			E40-3237-05 E40-3238-05 E40-3239-05 E40-3240-05 E40-3241-05	PIN CONNECTOR (MINI,2P) PIN CONNECTOR (MINI,3P) PIN CONNECTOR (MINI,4P) PIN CONNECTOR (MINI,5P) PIN CONNECTOR (MINI,6P)		
-			E40-3242-05	PIN CONNECTOR (MINI,7P)		
L1 -4 L50 T1			L40-1011-13 L40-1011-14 L19-0305-05	SMALL FIXED INDUCTOR SMALL FIXED INDUCTOR OSC TRANSFORMER		
RB1 RB2 RB3 RB4			R90-0511-05 R90-0193-05 R90-0520-05 R90-0515-05	MULTI-COMP 47KX8 MULTI-COMP 47KX9 J 1/6W MULTI-COMP 47KX5 MULTI-COMP 10KX4		
S50 S51 ,52			S40-2441-15 S40-2440-15	PUSH SWITCH PUSH SWITCH		

PARTS LIST

× New Parts

Parts without Parts No. are not supplied.

Les articles non mentionnés dans le Parts No. ne sont pas fournis.

Telle ohne Parts No. werden nicht geliefert.

Ref. No. 参照番号	Address 位置	New Parts 新	Parts No. 部品番号	Description 部品名 / 規格	Desti- nation 仕向	Re- marks 備考
S53			S31-2405-05	SLIDE SWITCH		
S54	-56		S40-2440-15	PUSH SWITCH		
S57			S40-2441-15	PUSH SWITCH		
S58	-60		S40-2440-15	PUSH SWITCH		
D1	-4		1S1555	DIODE		
D5	,6		MTZ6.2JA	ZENER DIODE		
D50	,51		1SS133	DIODE		
D52			1SS101	DIODE		
IC1		*	UPD6300C	IC (FL LATCH DRIVER)		
IC2			MB4052	IC (4CH 8BIT A/D CONVERTER (ADC))		
IC3			TC4013BP	IC (D FLIP-FLOP X2)		
PL1		*	FIP13BM7	FLUORESCENT INDICATOR TUBE		
Q1	,2		DTA114ES	DIGITAL TRANSISTOR		
Q3			DTC144WS	DIGITAL TRANSISTOR		
Q4	,5		2SC1959(Y)	TRANSISTOR		
Q50			DTC143TS	DIGITAL TRANSISTOR		
AT UNIT (X57-1150-00)						
C1	,2		C91-0117-05	CERAMIC 0.01UF K		
C3	,4		CK45B1H102K	CERAMIC 1000PF K		
C5			C91-0119-05	CERAMIC 0.047UF K		
C6			CK45B1H102K	CERAMIC 1000PF K		
C7			C91-0119-05	CERAMIC 0.047UF K		
C8			CK45B1H102K	CERAMIC 1000PF K		
C9			C91-0119-05	CERAMIC 0.047UF K		
C10			CE04W1H100M	ELECTRO 10UF 50WV		
C11			CE04W1C470M	ELECTRO 47UF 16WV		
C12			C91-0119-05	CERAMIC 0.047UF K		
C13	-15		C91-0117-05	CERAMIC 0.01UF K		
C16			CK45F1H473Z	CERAMIC 0.047UF Z		
C17	,18		C91-0117-05	CERAMIC 0.01UF K		
C19			CE04W1E101M	ELECTRO 100UF 25WV		
C20			C91-0117-05	CERAMIC 0.01UF K		
C21			CK45F1H473Z	CERAMIC 0.047UF Z		
C22			C91-0117-05	CERAMIC 0.01UF K		
C23			C91-0119-05	CERAMIC 0.047UF K		
C24			CG92M1H333K	MYLAR 0.033UF K		
C25			CK45B1H102K	CERAMIC 1000PF K		
C26			CE04W1H010M	ELECTRO 1.0UF 50WV		
C27			CE04W1H100M	ELECTRO 10UF 50WV		
C28	,29		CK45F1H103Z	CERAMIC 0.010UF Z		
C30			C91-0117-05	CERAMIC 0.01UF K		
C31			CC45SL2H560J	CERAMIC 56PF J		
C100-105			CK45F1H473Z	CERAMIC 0.047UF Z		
C106-111			CK45F1H103Z	CERAMIC 0.010UF Z		
C112			CK45F1H473Z	CERAMIC 0.047UF Z		
TC1			CO5-0324-05	TRIMMING CAP 60PF		
VC1	,2	*	CO2-0023-05	VARIABLE CAPACITOR		
163	2P	*	D40-0629-05	GEAR MECHANISM ASSY		
-			ED4-0157-05	RF COAXIAL CABLE RECEPTACLE		
-			E40-0273-05	PIN CONNECTOR (MINI,2P)		
-			E40-0473-05	PIN CONNECTOR (MINI,4P)		
-			E40-0673-05	PIN CONNECTOR (MINI,6P)		
-			E40-0873-05	PIN CONNECTOR (MINI,8P)		

PARTS LIST

* New Parts

Parts without Parts No. are not supplied.

Les articles non mentionnés dans le Parts No. ne sont pas fournis.

Teile ohne Parts No. werden nicht geliefert.

Ref. No. 参照番号	Address 位置	New Parts 新	Parts No. 部品番号	Description 部品名 / 規格	Desti- nation 仕向	Re- marks 備考
-			L92-0103-05	TRISIDAL CORE (FOR L1,2)		
-		*	L92-0119-05	TRISIDAL CORE (FOR T100,101)		
L1			L39-0416-05	COIL		
L2			L39-0415-05	COIL		
L3			L40-1011-13	SMALL FIXED INDUCTOR		
L4			L40-1011-14	SMALL FIXED INDUCTOR		
L5 -11			L40-1011-13	SMALL FIXED INDUCTOR		
L12			L40-1011-14	SMALL FIXED INDUCTOR		
L13 ,14			L40-1011-13	SMALL FIXED INDUCTOR		
L100			L40-1011-13	SMALL FIXED INDUCTOR		
T100		*	L34-3144-15	COIL		
T101		*	L34-3145-15	COIL		
T102		*	L34-3146-15	COIL		
B	1P, 1Q		N88-3006-46	FLAT HEAD TAPTITE SCREW		
M	1Q, 2R		N87-2606-46	BRAZIER HEAD TAPTITE SCREW		
N	2P, 1R		N87-3006-46	BRAZIER HEAD TAPTITE SCREW		
R1		*	RC05GF2H510J	RC 51 J 1/2W		
VR1 ,2			R12-3425-05	TRIMMING PNT. (10K)AUT. ANT TUN		
W11			R92-0150-05	JUMPER REST 0 OHM		
W16 ,17			R92-1061-05	JUMPER REST 0 OHM		
W19			R92-0150-05	JUMPER REST 0 OHM		
RL1		*	S51-2417-05	RELAY (DC-2, 12V)		
RL 100-105			S51-1420-05	RELAY (DC-1, 12V)		
M1 ,2			T42-0303-05	DC MOTOR ASSY		
D1 -4			1S599	DIODE		
D5 ,6		*	U26. 2BL	ZENER DIODE		
D7			1S5133	DIODE		
D8			1N4448	DIODE		
D8			1S1555	DIODE		
D9			1S5133	DIODE		
D10 ,11			1N60	DIODE		
D12			1S5133	DIODE		
D100-105			1N4448	DIODE		
D100-105			1S1555	DIODE		
IC1			NJM2903D	IC(DUAL COMPARATOR)		
IC2			HD10116	IC(TRIPLE LINE RECEIVERS)		
IC2			MC10116L	IC		
IC3			HD10131	IC(D FLIP-FLOP)		
IC3			MC10131L	IC		
IC4			HD10125	IC(QUAD ECL-TTL TRANSLATORS)		
IC4			MC10125L	IC		
IC5 ,6			BA6109U2	IC(MOTOR DRIVER)		
IC7			NE555P	IC		
IC8			MB3614	IC(QUAD OPERATIONAL AMPLIFIER)		
Q1		*	DTC114ES	DIGITAL TRANSISTOR		
Q2			2SA950(Y)	TRANSISTOR		
Q3		*	DTC114ES	DIGITAL TRANSISTOR		
Q4			2SA950(Y)	TRANSISTOR		
Q5			2SC2458(Y)	TRANSISTOR		
Q6		*	DTC114ES	DIGITAL TRANSISTOR		
Q7			DTC124ES	DIGITAL TRANSISTOR		
Q100-105			2SC2668(Y)	TRANSISTOR		

PARTS LIST

× New Parts

Parts without Parts No. are not supplied.

Les articles non mentionnés dans le Parts No. ne sont pas fournis.

Teile ohne Parts No. werden nicht geliefert.

Ref. No. 参照番号	Address 位置	New Parts 新	Parts No. 部品番号	Description 部品名 / 規格	Desti- nation 仕向	Re- marks 備考
SIDE TONE UNIT (X59-1060-00)						
C1			CK73FB1E223K	CHIP C 0.022UF K		
C2 -5		*	CK73FB1H123K	CHIP C 0.012UF K		
C6 -8			CK73FB1E223K	CHIP C 0.022UF K		
-			E23-0471-05	TERMINAL		
R1 .2			RK73FB2A823J	CHIP R 82K J 1/10W		
R3			RK73FB2A223J	CHIP R 22K J 1/10W		
R4			RK73FB2A472J	CHIP R 4.7K J 1/10W		
R5			RK73FB2A102J	CHIP R 1.0K J 1/10W		
R6			RK73FB2A103J	CHIP R 10K J 1/10W		
R7 .8			RK73FB2A333J	CHIP R 33K J 1/10W		
R9			RK73FB2A103J	CHIP R 10K J 1/10W		
R10			RK73FB2A333J	CHIP R 33K J 1/10W		
R11			RK73FB2A183J	CHIP R 18K J 1/10W		
W1 -6			R92-0670-05	CHIP R 0 OHM		
D1			DAN202(K)	CHIP DIODE		
D2			DAP202(K)	CHIP DIODE		
D3			DAN202(K)	CHIP DIODE		
Q1			2SC2712(Y)	CHIP TRANSISTOR		
SELECTIVITY UNIT (X59-1070-00)						
-			E23-0471-05	TERMINAL		
R1			RK73FB2A473J	CHIP R 47K J 1/10W		
R2			RK73FB2A103J	CHIP R 10K J 1/10W		
R3			RK73FB2A473J	CHIP R 47K J 1/10W		
R4			RK73FB2A103J	CHIP R 10K J 1/10W		
R5			RK73FB2A473J	CHIP R 47K J 1/10W		
R6			RK73FB2A103J	CHIP R 10K J 1/10W		
R7			RK73FB2A473J	CHIP R 47K J 1/10W		
R8			RK73FB2A103J	CHIP R 10K J 1/10W		
W1 -3			R92-0670-05	CHIP R 0 OHM		
D1 .2			DAN202(K)	CHIP DIODE		
D3			DAP202(K)	CHIP DIODE		
D4 .5			DAN202(K)	CHIP DIODE		
D6			DAP202(K)	CHIP DIODE		
Q1 -4			2SA1162(Y)	CHIP TRANSISTOR		
VOX. UNIT (X59-1080-00)						
C1			CK73FB1H102K	CHIP C 1000PF K		
C2			CK73FB1E223K	CHIP C 0.022UF K		
-			E23-0471-05	TERMINAL		
R1			RK73FB2A104J	CHIP R 100K J 1/10W		
R2 -5			RK73FB2A103J	CHIP R 10K J 1/10W		
R6 .7			RK73FB2A105J	CHIP R 1.0M J 1/10W		
R8			RK73FB2A474J	CHIP R 470K J 1/10W		
R9			RK73FB2A105J	CHIP R 1.0M J 1/10W		
R10			RK73FB2A103J	CHIP R 10K J 1/10W		
W1 -3			R92-0670-05	CHIP R 0 OHM		
D1 .2			DAP202(K)	CHIP DIODE		
IC1			NJM2904M	IC(OP AMP X2)		
IC2		*	TC4001BF	IC(NOR X6)		
Q1			2SC2712(Y)	CHIP TRANSISTOR		

× New Parts

Parts without Parts No. are not supplied.

Les articles non mentionnes dans le Parts No. ne sont pas fournis.

Teile ohne Parts No. werden nicht geliefert.

Ref. No. 参照番号	Address 位置	New Parts 新	Parts No. 部品番号	Description 部品名 / 規格	Desti- nation 仕向	Re- marks 備考
IF UNIT (X60-1300-00)						
C1			C91-0769-05	CERAMIC	0.01UF	M
C2			CC45SL1H150J	CERAMIC	15PF	J
C3	-6		C91-0769-05	CERAMIC	0.01UF	M
C7			CC45SL1H150J	CERAMIC	15PF	J
CB	-10		C91-0769-05	CERAMIC	0.01UF	M
C11			C91-0117-05	CERAMIC	0.01UF	K
C12	,13		CK45F1H103Z	CERAMIC	0.010UF	Z
C14	-16		C91-0119-05	CERAMIC	0.047UF	K
C17			CK45F1H223Z	CERAMIC	0.022UF	Z
C18	-22		C91-0119-05	CERAMIC	0.047UF	K
C24			C91-1008-05	CERAMIC	0.022UF	K
C25	-30		C91-0119-05	CERAMIC	0.047UF	K
C31			CC45SL1H050C	CERAMIC	5.0PF	C
C32	-34		C91-0119-05	CERAMIC	0.047UF	K
C35			CK45F1H223Z	CERAMIC	0.022UF	Z
C36	,37		C91-0119-05	CERAMIC	0.047UF	K
C38			C91-0769-05	CERAMIC	0.01UF	M
C39			CE04W1H0R1M	ELECTR0	0.1UF	50WV
C39	,40		C91-0119-05	CERAMIC	0.047UF	K
C41			C91-1008-05	CERAMIC	0.022UF	K
C43			C91-0119-05	CERAMIC	0.047UF	K
C44			CC45SL1H101J	CERAMIC	100PF	J
C45			CK45B1H102K	CERAMIC	1000PF	K
C46	,47		C91-0119-05	CERAMIC	0.047UF	K
C48			CC45UJ1H470J	CERAMIC	47PF	J
C49			CC45UJ1H680J	CERAMIC	68PF	J
C50			CK45F1H103Z	CERAMIC	0.010UF	Z
C51			CC92M1H333K	MYLAR	0.033UF	K
C52			CE04W1H4R7M	ELECTR0	4.7UF	50WV
C53			CE04W1HR47M	ELECTR0	0.47UF	50WV
C54			CK45B1H102K	CERAMIC	1000PF	K
C55			CK45B1H221K	CERAMIC	220PF	K
C56			CC92M1H103K	MYLAR	0.010UF	K
C57			CE04W1H100M	ELECTR0	10UF	50WV
C58			CE04W1H010M	ELECTR0	1.0UF	50WV
C59			CE04W1H4R7M	ELECTR0	4.7UF	50WV
C60			CC92M1H473K	MYLAR	0.047UF	K
C61			CC92M1H103K	MYLAR	0.010UF	K
C62			CC92M1H333K	MYLAR	0.033UF	K
C63			CE04W1A101M	ELECTR0	100UF	10WV
C64			CE04W1H100M	ELECTR0	10UF	50WV
C65			CC92M1H392K	MYLAR	3900PF	K
C66	,67		CE04W1HR47M	ELECTR0	0.47UF	50WV
C68			CE04W1HR22M	ELECTR0	0.22UF	50WV
C70			CE04W1A470M	ELECTR0	47UF	10WV
C71			CE04W1HR22M	ELECTR0	0.22UF	50WV
C72			CC92M1H822K	MYLAR	8200PF	K
C73	,74		CE04W1H4R7M	ELECTR0	4.7UF	50WV
C76	,77		C91-0119-05	CERAMIC	0.047UF	K
C78			CE04W1H2R2M	ELECTR0	2.2UF	50WV
C79			CE04W1H010M	ELECTR0	1.0UF	50WV
C80			C91-0119-05	CERAMIC	0.047UF	K
C81			CC45SL1H101J	CERAMIC	100PF	J

PARTS LIST

* New Parts

Parts without Parts No. are not supplied.

Les articles non mentionnes dans le Parts No. ne sont pas fournis.

Teile ohne Parts No. werden nicht geliefert.

Ref. No. 参照番号	Address 位置	New Parts 新	Parts No. 部品番号	Description 部品名 / 規格	Desti- nation 仕 向	Re- marks 備考
C82 -84			CK45B1H102K	CERAMIC 1000PF K		
C85		*	C90-2022-05	ELECTRØ 15UF 16WV		
C86 ,87			C91-0119-05	CERAMIC 0.047UF K		
C88			CC45SL1H120J	CERAMIC 12PF J		
C89			CQ92M1H152K	MYLAR 1500PF K		
C90			CQ92M1H183K	MYLAR 0.018UF K		
C91			CQ92M1H103K	MYLAR 0.010UF K		
C92			CE04W1A220M	ELECTRØ 22UF 10WV		
C93			CQ92M1H682K	MYLAR 6800PF K		
C94			CE04W1H4R7M	ELECTRØ 4.7UF 50WV		
C95			CC45SL1H470J	CERAMIC 47PF J		
C95			CQ92M1H473K	MYLAR 0.047UF K		
C96			C91-0769-05	CERAMIC 0.01UF M		
C97			CC45SL1H390J	CERAMIC 39PF J		
C99			C91-0769-05	CERAMIC 0.01UF M		
C100			C91-0119-05	CERAMIC 0.047UF K		
C101			CK45B1H102K	CERAMIC 1000PF K		
C102			C91-0769-05	CERAMIC 0.01UF M		
C103			CE04W1H100M	ELECTRØ 10UF 50WV		
C104			CC45SL1H470J	CERAMIC 47PF J		
C105			CK45B1H221K	CERAMIC 220PF K		
C106			C91-0119-05	CERAMIC 0.047UF K		
C107			CC45SL1H470J	CERAMIC 47PF J		
C108			CE04W1H010M	ELECTRØ 1.0UF 50WV		
C109			CE04W1HR47M	ELECTRØ 0.47UF 50WV		
C110			CS15E1ER47M	TANTAL 0.47UF 25WV		
C111			CE04W1H010M	ELECTRØ 1.0UF 50WV		
C112			CE04W1H100M	ELECTRØ 10UF 50WV		
C113			CE04W1H4R7M	ELECTRØ 4.7UF 50WV		
C114			CE04W1H010M	ELECTRØ 1.0UF 50WV		
C115			C91-0117-05	CERAMIC 0.01UF K		
C116			CC45SL1H101J	CERAMIC 100PF J		
C117			CE04W1A470M	ELECTRØ 47UF 10WV		
C118			CE04W1H010M	ELECTRØ 1.0UF 50WV		
C119			CE04W1H100M	ELECTRØ 10UF 50WV		
C120			CQ92M1H103K	MYLAR 0.010UF K		
C121			CE04W1H010M	ELECTRØ 1.0UF 50WV		
C122-124			CC45SL1H101J	CERAMIC 100PF J		
C125			CE04W1H010M	ELECTRØ 1.0UF 50WV		
C126			CE04W1H4R7M	ELECTRØ 4.7UF 50WV		
C127,128			CE04W1H010M	ELECTRØ 1.0UF 50WV		
C129			CE04W1A470M	ELECTRØ 47UF 10WV		
C130			CE04W1H100M	ELECTRØ 10UF 50WV		
C131			CE04W1H4R7M	ELECTRØ 4.7UF 50WV		
C132,133			CE04W1H010M	ELECTRØ 1.0UF 50WV		
C134			CE04W1A470M	ELECTRØ 47UF 10WV		
C136			CE04W1A470M	ELECTRØ 47UF 10WV		
C137			CK45B1H102K	CERAMIC 1000PF K		
C138-140			C91-0119-05	CERAMIC 0.047UF K		
C141			CE04W1A470M	ELECTRØ 47UF 10WV		
C142			C91-0119-05	CERAMIC 0.047UF K		
C143			C91-0769-05	CERAMIC 0.01UF M		
C146			C91-0119-05	CERAMIC 0.047UF K		
C147			C91-0117-05	CERAMIC 0.01UF K		
C148,149			C91-0119-05	CERAMIC 0.047UF K		

PARTS LIST

× New Parts

Parts without Parts No. are not supplied.

Les articles non mentionnés dans le Parts No. ne sont pas fournis.

Teile ohne Parts No. werden nicht geliefert.

Ref. No. 参照番号	Address 位置	New Parts 新	Parts No. 部品番号	Description 部品名 / 規格	Desti- nation 仕 向	Re- marks 備考
C150			C91-0117-05	CERAMIC 0.01UF K		
C151,152			C91-0119-05	CERAMIC 0.047UF K		
C153			CC45SL1H470J	CERAMIC 47PF J		
C154,155			C91-0119-05	CERAMIC 0.047UF K		
C156			CC45SL1H180J	CERAMIC 18PF J		
C158,159			C91-0119-05	CERAMIC 0.047UF K		
C160			C91-0117-05	CERAMIC 0.01UF K		
C161			CC45SL1H470J	CERAMIC 47PF J		
C162-165			C91-0769-05	CERAMIC 0.01UF M		
C166			CE04W1H010M	ELECTR0 1.0UF 50WV		
C167			C91-0769-05	CERAMIC 0.01UF M		
C168			CE04W1HR47M	ELECTR0 0.47UF 50WV		
C169			C092M1H472K	MYLAR 4700PF K		
C170			CE04W1H100M	ELECTR0 10UF 50WV		
C171			CE04W1HR47M	ELECTR0 0.47UF 50WV		
C172			CE04W1C101M	ELECTR0 100UF 16WV		
C173			C90-0866-05	ELECTR0 470UF 6.3WV		
C174			C092M1H104K	MYLAR 0.10UF K		
C175			C90-0864-05	ELECTR0 220UF 10WV		
C176			C092M1H103K	MYLAR 0.010UF K		
C177			CE04W1HR47M	ELECTR0 0.47UF 50WV		
C178			CE04W1A470M	ELECTR0 47UF 10WV		
C179			CE04W1H4R7M	ELECTR0 4.7UF 50WV		
C180			CE04W1A470M	ELECTR0 47UF 10WV		
C181,182			C092M1H473K	MYLAR 0.047UF K		
C183			C092M1H182K	MYLAR 1800PF K		
C184			CK45B1H471K	CERAMIC 470PF K		
C185			C91-0117-05	CERAMIC 0.01UF K		
C186			CC45UJ1H100D	CERAMIC 10PF D		
C187			CK45B1H471K	CERAMIC 470PF K		
C188			CC45SL1H330J	CERAMIC 33PF J		
C189			C91-0769-05	CERAMIC 0.01UF M		
C190			CC45SL1H050C	CERAMIC 5.0PF C		
C191			CC45SL1H030C	CERAMIC 3.0PF C		
C194			C91-0117-05	CERAMIC 0.01UF K		
C196			CK45B1H561K	CERAMIC 560PF K		
C197			CE04W1A470M	ELECTR0 47UF 10WV		
C198			CK45F1H223Z	CERAMIC 0.022UF Z		
C199,200			CE04W1A470M	ELECTR0 47UF 10WV		
C201			C91-0119-05	CERAMIC 0.047UF K		
C202			CK45F1H223Z	CERAMIC 0.022UF Z		
C203			C91-0119-05	CERAMIC 0.047UF K		
C204			C91-1008-05	CERAMIC 0.022UF K		
C205			C91-0769-05	CERAMIC 0.01UF M		
C206			CE04W1H100M	ELECTR0 10UF 50WV		
C207			CK45B1H222K	CERAMIC 2200PF K		
C208			CE04W1H100M	ELECTR0 10UF 50WV		
C209,210			C91-0119-05	CERAMIC 0.047UF K		
TC1			C05-0315-05	TRIMMING CAP (60P)		
TC2			C05-0030-15	TRIMMING CAP (20P)		
-			E40-0273-05	PIN CONNECTOR (MINI,2P)		
-			E40-0373-05	PIN CONNECTOR (MINI,3P)		
-			E40-0473-05	PIN CONNECTOR (MINI,4P)		
-			E40-0573-05	PIN CONNECTOR (MINI,5P)		
-			E40-0673-05	PIN CONNECTOR (MINI,6P)		

PARTS LIST

* New Parts

Parts without Parts No. are not supplied.

Les articles non mentionnes dans le Parts No. ne sont pas fournis.

Teile ohne Parts No. werden nicht geliefert.

Ref. No. 参照番号	Address 位置	New Parts 新	Parts No. 部品番号	Description 部品名/規格	Desti- nation 仕向	Re- marks 備考
-			E40-0773-05	PIN CONNECTOR (MINI,7P)		
-			E40-0973-05	PIN CONNECTOR (MINI,9P)		
-			E40-1073-05	PIN CONNECTOR (MINI,10P)		
-			F02-0424-04	HEAT SINK		
CF1		*	L72-0356-05	CERAMIC FILTER		
CF2		*	L72-0355-05	CERAMIC FILTER		
CF3			L72-0315-05	CERAMIC FILTER		
CF4			L72-0351-05	CERAMIC FILTER		
L1			L34-0700-05	COIL		
L2			L34-0943-05	COIL		
L3	.4		L34-0664-05	COIL		
L5			L34-0945-05	COIL		
L6			L30-0503-05	IFT		
L7			L40-4711-13	SMALL FIXED INDUCTOR		
L9			L40-1021-13	SMALL FIXED INDUCTOR		
L10			L40-1511-14	SMALL FIXED INDUCTOR		
L11			L40-1011-14	SMALL FIXED INDUCTOR		
L12			L34-0535-05	COIL		
L13			L40-1011-14	SMALL FIXED INDUCTOR		
L14			L40-3391-13	SMALL FIXED INDUCTOR		
L15			L32-0201-05	OSCILLATING COIL		
L16			L40-3392-02	SMALL FIXED INDUCTOR		
L18			L34-2124-05	COIL		
L19			L40-1021-03	SMALL FIXED INDUCTOR		
L20			L40-1011-14	SMALL FIXED INDUCTOR		
L21			L40-6825-04	SMALL FIXED INDUCTOR		
X1		*	L77-1302-05	CRYSTAL RESONATOR		
-			N09-0641-05	SCREW		
-			N30-3004-46	PAN HEAD MACHINE SCREW		
VR1		*	R12-7407-05	TRIMMING PNT. (500K)		
VR2			R12-3447-05	TRIMMING PNT. (10K)S-METER,SSB		
VR3			R12-4414-05	TRIMMING PNT. (50K)S-METER		
VR4	.5		R12-2414-05	TRIMMING PNT. (5K)VOLTAGE,ETC.		
VR6			R12-5417-05	TRIMMING PNT. (100K)SPEECH PROC		
VR7			R12-2414-05	TRIMMING PNT. (5K)CARRIER SUP		
VR8			R12-3447-05	TRIMMING PNT. (10K)CARRIER SUP		
VR9	.10		R12-4414-05	TRIMMING PNT. (50K)CW SIDE TONE		
W9			R92-0150-05	JUMPER REST 0 OHM		
W24			R92-0150-05	JUMPER REST 0 OHM		
W43	.44		R92-0150-05	JUMPER REST 0 OHM		
W49			R92-0150-05	JUMPER REST 0 OHM		
W51	.52		R92-0150-05	JUMPER REST 0 OHM		
W55			R92-0150-05	JUMPER REST 0 OHM		
D1	-6		1S1007	DIODE		
D7	.8		1S1587	DIODE		
D9			1SS133	DIODE		
D10			1S1587	DIODE		
D11			1SS133	DIODE		
D12	-18		1S1587	DIODE		
D19	-22		1N60	DIODE		
D23	-29		1SS133	DIODE		
D30			1N60	DIODE		
D31	-34		1SS133	DIODE		

PARTS LIST

* New Parts

Parts without Parts No. are not supplied.

Les articles non mentionnés dans le Parts No. ne sont pas fournis.

Teile ohne Parts No. werden nicht geliefert.

Ref. No. 参照番号	Address 位置	New Parts 新	Parts No. 部品番号	Description 部品名 / 規格	Desti- nation 仕向	Re- marks 備考
D35			1N60	DIODE		
D36			1S1587	DIODE		
D37 ,38			1S1555	DIODE		
D39			1N60	DIODE		
D40			1S1555	DIODE		
D41			1SS133	DIODE		
D42 ,43			1N60	DIODE		
D45 ,46			1SS133	DIODE		
D47			MI204	DIODE		
D48 ,49			1SS133	DIODE		
D50			1S1587	DIODE		
D51			MTZ9. 1JB	DIODE		
D52			V06B	DIODE		
D53 ,54			1S1587	DIODE		
D55			MTZ6. 2JA	DIODE		
D56 -59			1SS133	DIODE		
D60			MC921	DIODE		
D61		*	DAN401	DIODE ARRAY		
D62			MC921	DIODE		
D63			1SS133	DIODE		
D65 ,66			1S1555	DIODE		
D67			1SS101	DIODE		
D68 -72			MC921	DIODE		
D74 ,75			MC921	DIODE		
D76 -80			1SS133	DIODE		
D81			1S1555	DIODE		
D82 -84			1SS133	DIODE		
IC1			BX7191	IC (NOTCH/PEAK FILTER)		
IC2			MC3357P	IC		
IC3		*	M74LS123P	IC (DUAL MONO MULTI)		
IC3		*	SN74LS123N	IC		
IC4			UPC1158H2	IC		
IC5 ,6			AN612	IC (BALANCED MODULATOR)		
IC7			UPC2002V	IC (OPE AMP X2)		
IC8 ,9		*	M74LS00P	IC		
IC8 ,9			SN74LS00N	IC		
IC10			BX6124	IC (2CH SWITCHING IC)		
Q1 ,2			3SK73 (GR)	FET		
Q3			2SC2458 (Y)	TRANSISTOR		
Q4			DTC114ES	DIGITAL TRANSISTOR		
Q5			3SK73 (GR)	FET		
Q6			DTC114ES	DIGITAL TRANSISTOR		
Q7 ,8			3SK73 (GR)	FET		
Q9			2SC2458 (Y)	TRANSISTOR		
Q10			2SC2459 (BL)	TRANSISTOR		
Q11			DTC114ES	DIGITAL TRANSISTOR		
Q12			2SC2459 (BL)	TRANSISTOR		
Q13			DTC114ES	DIGITAL TRANSISTOR		
Q14			DTC143TS	DIGITAL TRANSISTOR		
Q15			DTC114ES	DIGITAL TRANSISTOR		
Q16			2SC2459 (BL)	TRANSISTOR		
Q17			2SC2458 (Y)	TRANSISTOR		
Q18			2SA1048 (Y)	TRANSISTOR		
Q19			2SC2458 (Y)	TRANSISTOR		
Q20			2SK192 (GR)	FET		

PARTS LIST

× New Parts

Parts without Parts No. are not supplied.

Les articles non mentionnés dans le Parts No. ne sont pas fournis.

Teile ohne Parts No. werden nicht geliefert.

Ref. No. 参照番号	Address 位置	New Parts 新	Parts No. 部品番号	Description 部品名 / 規格	Desti- nation 仕 向	Re- marks 備考
Q21			2SA1048(Y)	TRANSISTOR		
Q22			DTC114ES	DIGITAL TRANSISTOR		
Q23 ,24			2SC2458(Y)	TRANSISTOR		
Q25 ,26			2SK30A(Ø)	FET		
Q27			2SA1048(Y)	TRANSISTOR		
Q28			DTC114ES	DIGITAL TRANSISTOR		
Q29 -32			DTC143TS	DIGITAL TRANSISTOR		
Q33		*	2SA562TM	TRANSISTOR		
Q34			2SC2458(Y)	TRANSISTOR		
Q35		*	2SA562TM	TRANSISTOR		
Q36 ,37			DTC114ES	DIGITAL TRANSISTOR		
Q38		*	2SA562TM	TRANSISTOR		
Q39			DTC114ES	DIGITAL TRANSISTOR		
Q40			2SC2459(BL)	TRANSISTOR		
Q41			DTC114ES	DIGITAL TRANSISTOR		
Q42			2SC2458(Y)	TRANSISTOR		
Q43			DTA114ES	DIGITAL TRANSISTOR		
Q44			2SC2459(BL)	TRANSISTOR		
Q45			2SC2458(Y)	TRANSISTOR		
Q46			3SK73(GR)	FET		
Q47 ,48			DTC143TS	DIGITAL TRANSISTOR		
Q49			2SA1048(Y)	TRANSISTOR		
Q50			DTC114ES	DIGITAL TRANSISTOR		
Q51			DTC143TS	DIGITAL TRANSISTOR		
Q52			2SC2459(BL)	TRANSISTOR		
Q53 ,54			2SC2458(Y)	TRANSISTOR		
Q55			DTC114ES	DIGITAL TRANSISTOR		
TH1 ,2			112-502-2	THERMISTOR		
TH3			32D27	THERMISTOR		
-		*	X59-1060-00	SIDE TONE UNIT		
-		*	X59-1070-00	SELECTIVITY UNIT		
-		*	X59-1080-00	Vox UNIT		

SWITCH UNIT (X41-1610-00) Component side view

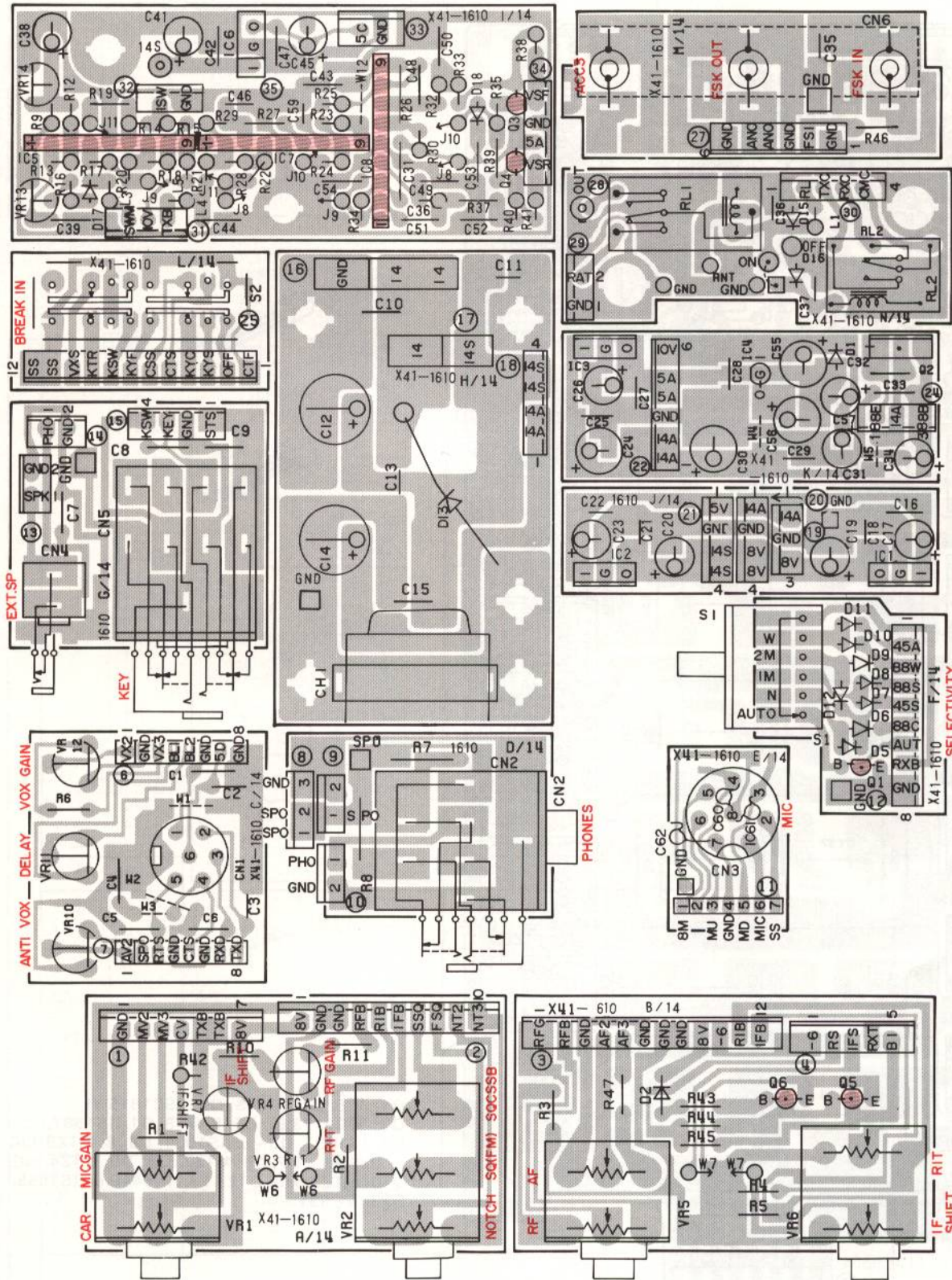

IC1: AN7808, IC2, 3, 6: AN7805, IC4: LM2931Z-5.0, IC5, 8: NJM2904S, IC7: NJM2903S, Q1: DTC114ES, Q2: 2SD1406(Y), Q3, 4: 2SK30(GR), Q5, 6: 2SC2458(Y), D1: 1S1555, D2: MTZ7. 5JA, D5~12, 15~18: 1SS133, D13: S31C

2SD1406(Y)

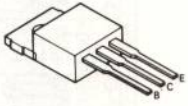

2SC2458(Y)
DTC114ES

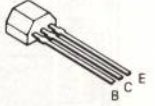

2SK30(GR)

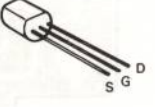

TS-440S PC BOARD VIEW

FILTER UNIT (X51-1340-00) Component side view

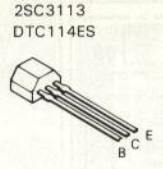
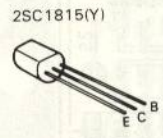
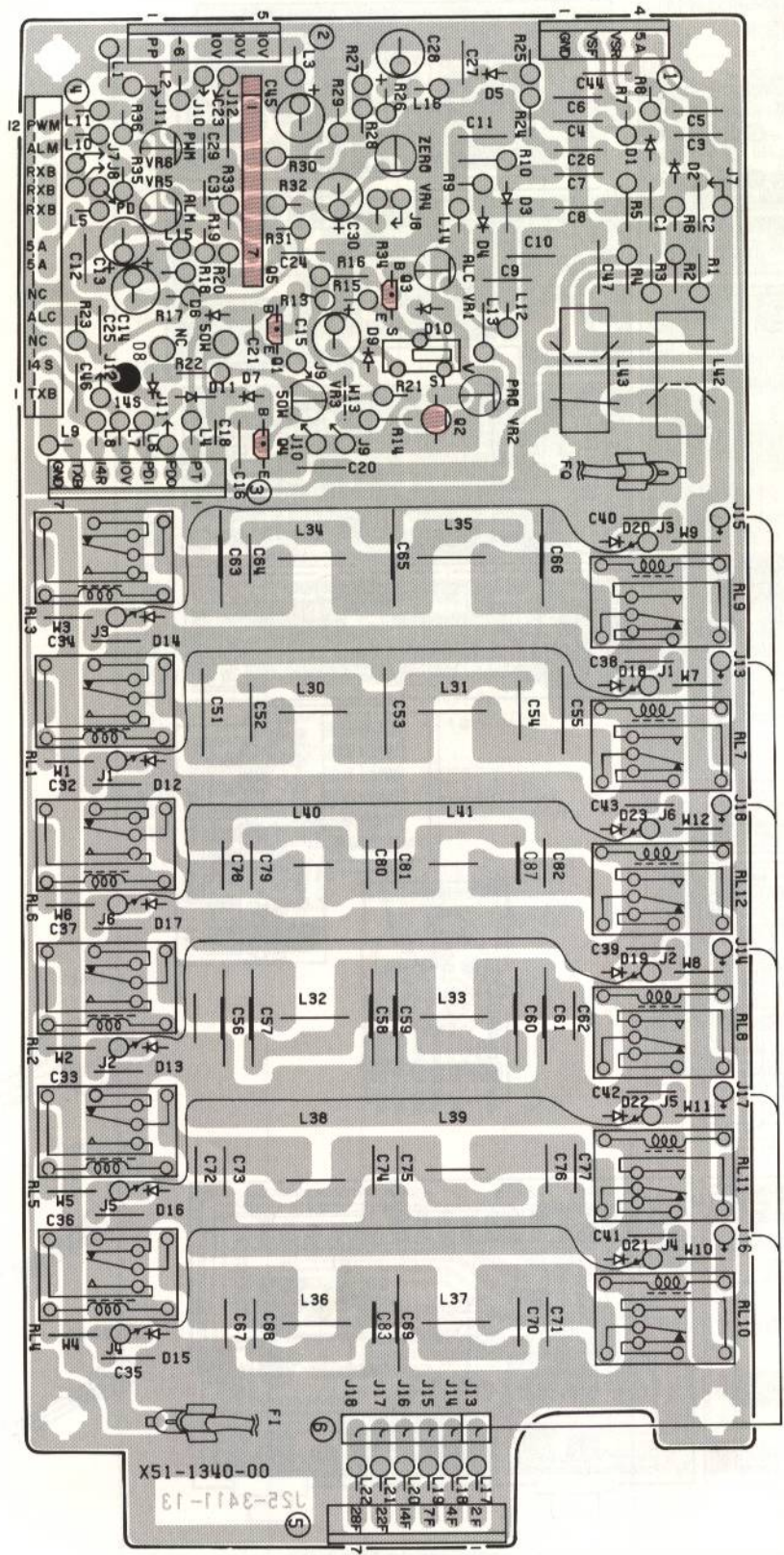

- Q1, 4, 6: DTC114ES, Q2: 2SC1815(Y),
- Q3: 2SC3113(B), Q5: BA718, D1: 1S1587,
- D2: 1S1007, D3~5: 1S1001, D6, 8: MTZ9.1JC
- or UZ9.1BL, D7, 25: MTZ7.5JA, D9: MTZ4.3JC,
- D10: MTZ3.0JB, D12~23: 1N4448 or 1S1555,
- D23: MC931

FILTER UNIT (X51-1340-00)

Refer to Schematic diagram on page 113.

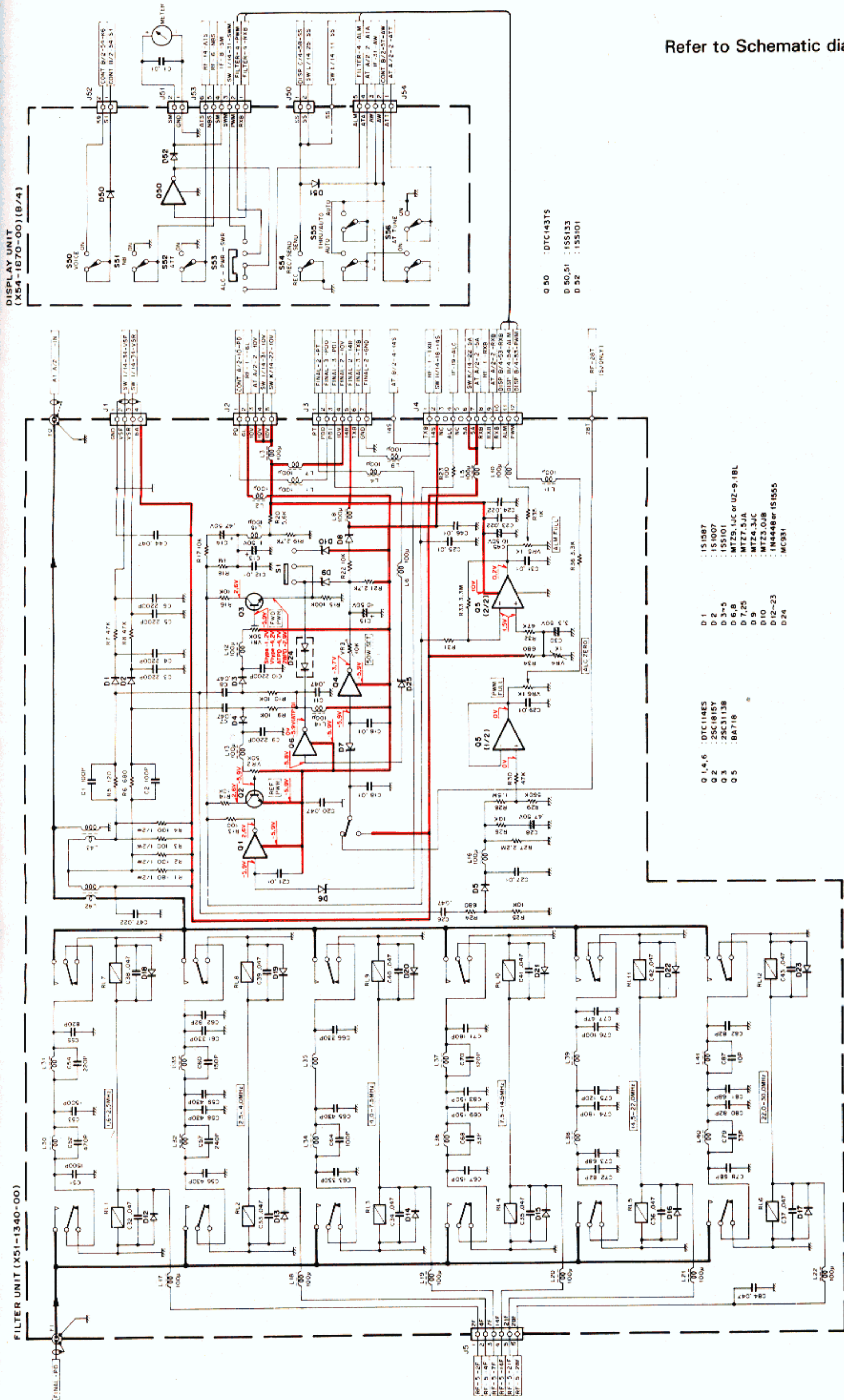

PLL UNIT (X50-2050-00) Component side view

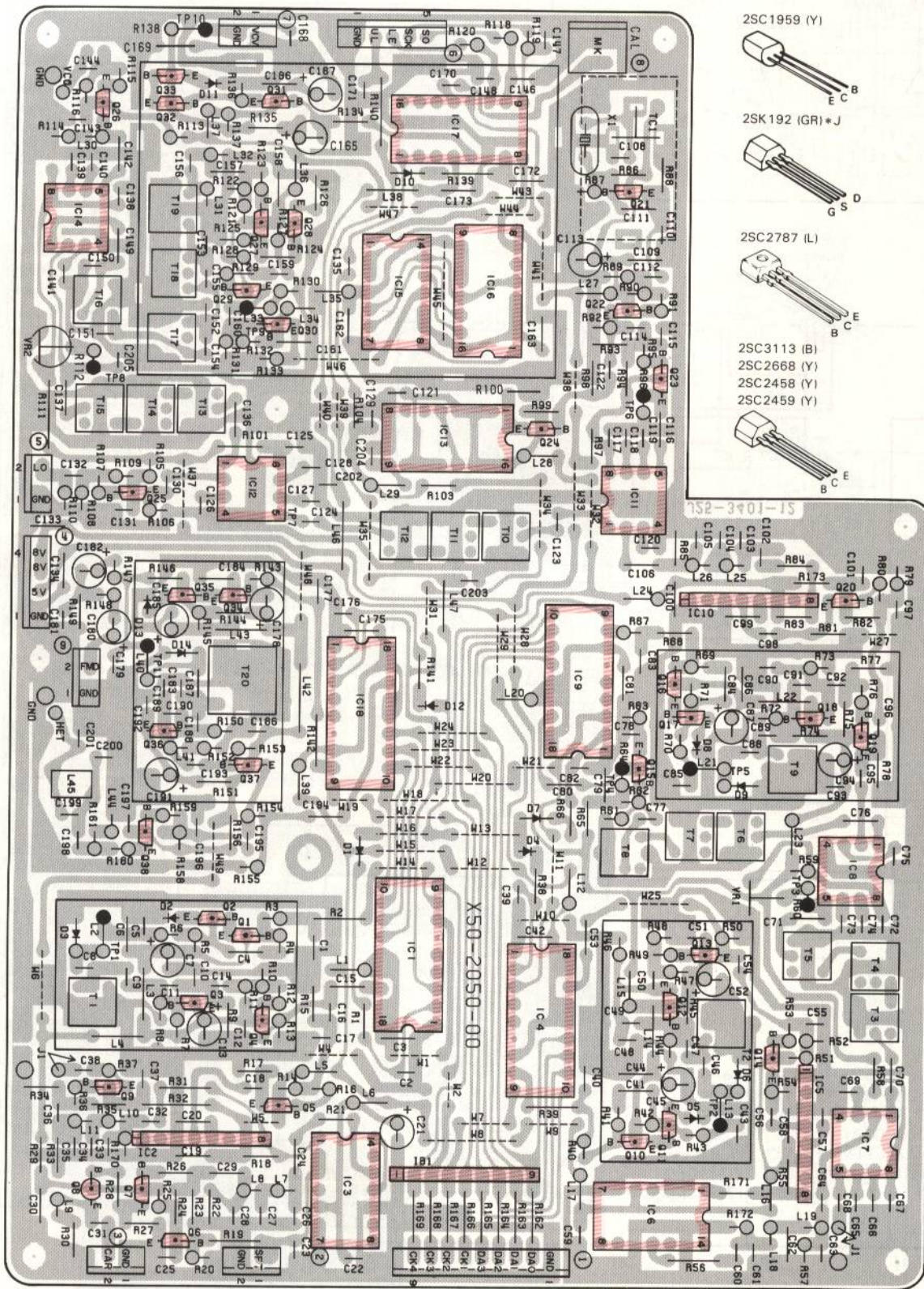

- 2SC1959 (Y)
- 2SK192 (GR)+J
- 2SC2787 (L)
- 2SC3113 (B)
- 2SC2668 (Y)
- 2SC2458 (Y)
- 2SC2459 (Y)

IC1, 4, 9, 18: NM6147, IC2: M54459L, IC3, 6: SN74LS90N, IC5, 10: M54460L, IC7, 8, 11, 12, 14: SN16913P, IC13, 16: SN74S112N, IC15: SN74S10N, IC17: MB87006, Q1, 2, 10, 11, 16, 17: 2SC3113(B), Q3-5, 12-15, 18-20, 22-24, 26-30, 37: 2SC2668(Y) Q6, 7, 9, 25: 2SC2458(Y), Q8: 2SC1959(Y), Q21: 2SC2787(L), Q31-35: 2SC2459(BL) Q36: 2SK192A (GR)+J

PLL UNIT (X50-2050-00) Component side view

PLL UNIT (X50-2050-00)

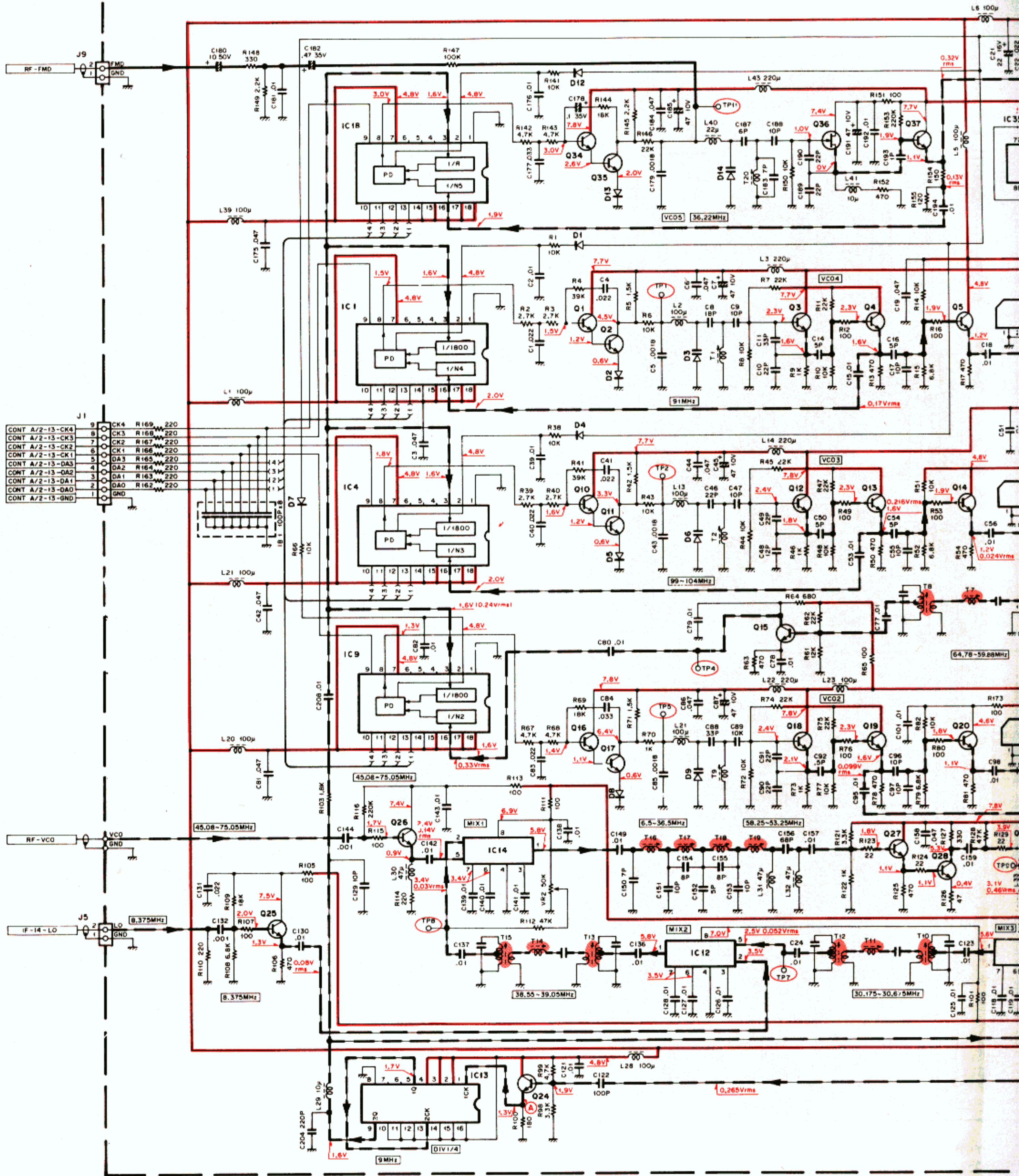

J1

9	CK4	R169	220
8	CK3	R168	220
7	CK2	R167	220
6	CK1	R166	220
5	DA3	R165	220
4	DA2	R164	220
3	DA1	R163	220
2	DA0	R162	220
1	GND		

IC 1, 4	: MN6147 or MN6147C	Q 1, 2, 10, 11, 16, 17	: 2SC3113(B)	D 1, 2, 4, 5, 7, 8, 10, 12	: 15S133
IC 2	: M54459L	Q 3-5, 12-15, 18-20, 22-24, 26-30,	: 25C2668(Y)	D 3	: 15V53A
IC 3, 6	: SN74LS90N	37, 38	: 25C2458(Y)	D 6, 9	: 1T310TE
IC 7, 8, 11, 12, 14	: SN16913P	Q 6, 7, 9, 25	: 25C1959(Y)	D 11	: MV13
IC 5, 10	: M54460L	Q 8	: 25C1959(Y)	D 13	: MV203
IC 13, 16	: SN745112N	Q 21	: 25C2787(L)	D 14	: 15V153
IC 15	: SN74510N	Q 31-35	: 25C2459(BL)		
IC 17	: MB87006	Q 36	: 25K192A(GR)		
IC 9, 18	: MN6147				

Refer to Schematic diagram on page 113.

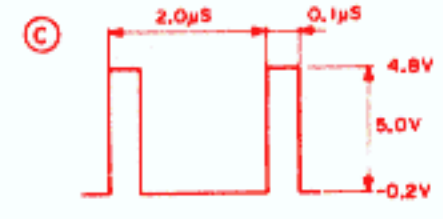
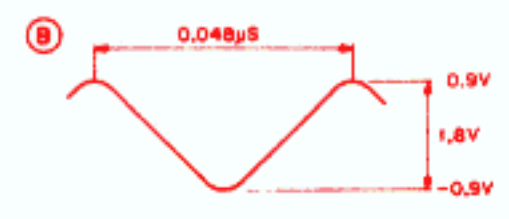
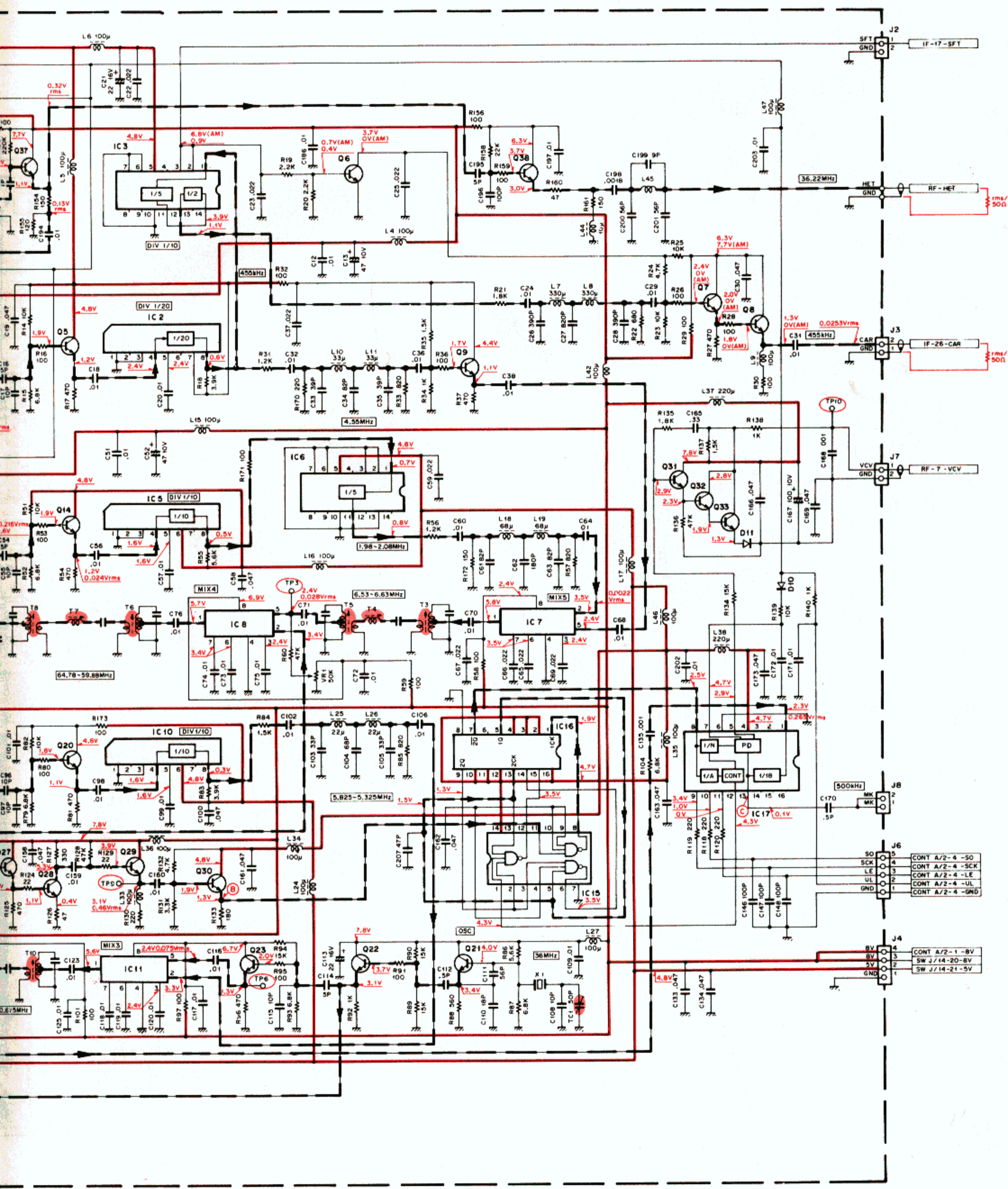

RF UNIT (X44-1680-00) Component side view

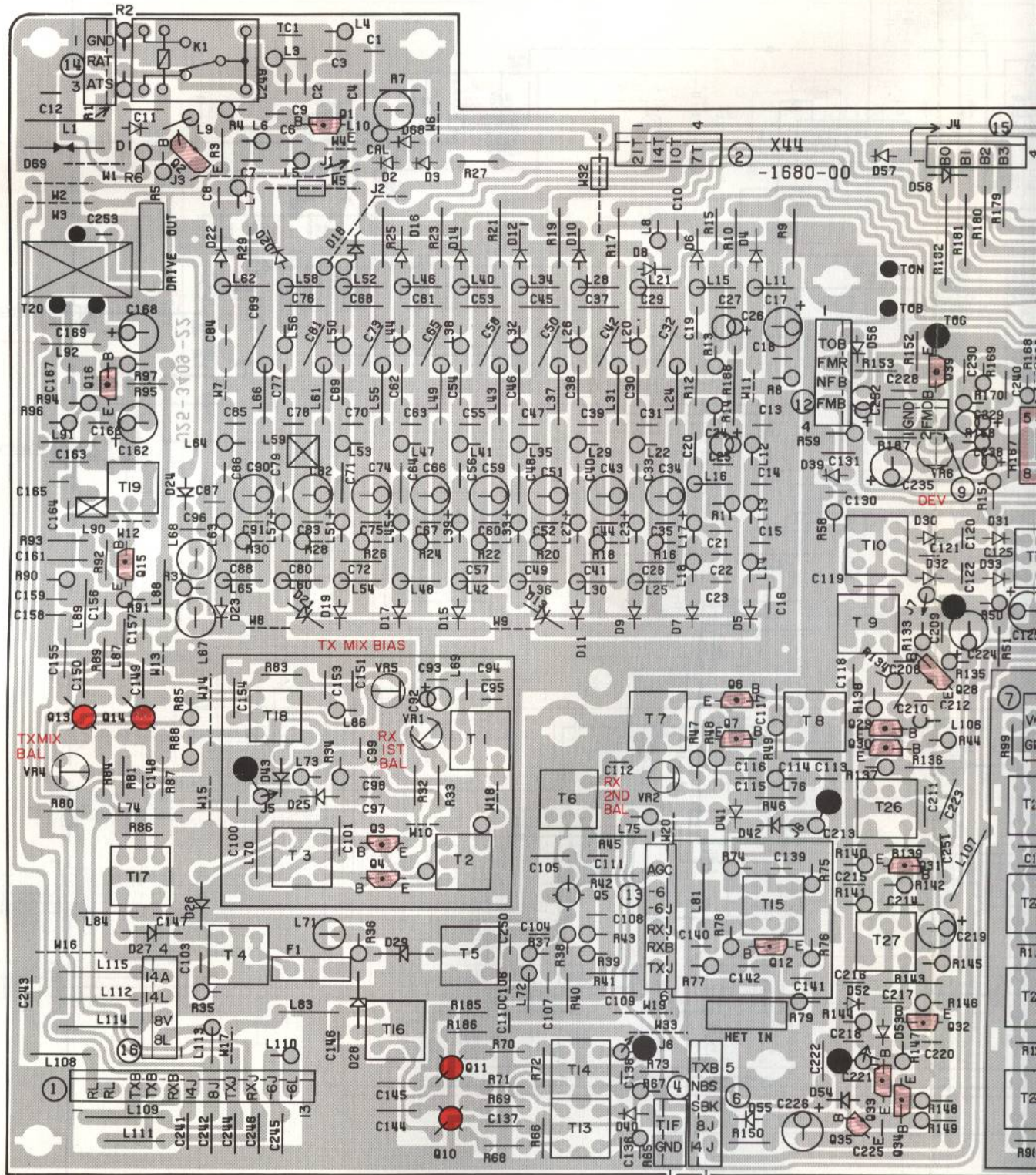

Q1, 36: 2SC2459(BL), Q2, 45: 2SA562(Y), Q3, 4, 6, 7: 2SK125-5, Q5: 3SK74(L), Q8, 9, 12, 21~25, 29~31: 2SC2668(Y), Q10, 11, 13, 14: 3SK122(L), Q15: 2SC2570A, Q16: 2SC2538, Q17~20: DTC143TS, Q26: 2SC1959(Y), Q27: 2SC2053, Q28: 2SK192A(IGR), Q32, 33, 35, 37, 39: 2SC2603(E), Q34, 46: DTC124ES, Q38: „PC4558C, Q40: M74LS145P or SN74LS145N, Q41: M54561P, D1: 1S1555, D2, 3: US1090, D4, 6, 8, 10, 12, 14, 16, 18, 20, 22: 1S2588, D5, 7, 9, 11, 13, 15, 17, 19, 21, 23, 26~29, 40: BA282, D24, 39, 56~58, 60, 66: 1S5133, D25, 34~38, 41~43, 45, 47, 49, 51: MA858, D30~33: 1S1587, D44, 46, 48, 50: ITT310TE, D52, 53: 1N60, D54: MV13, D59: VZ3.OB, D67: DAN401, D68: US1090, D69, DSP-301N

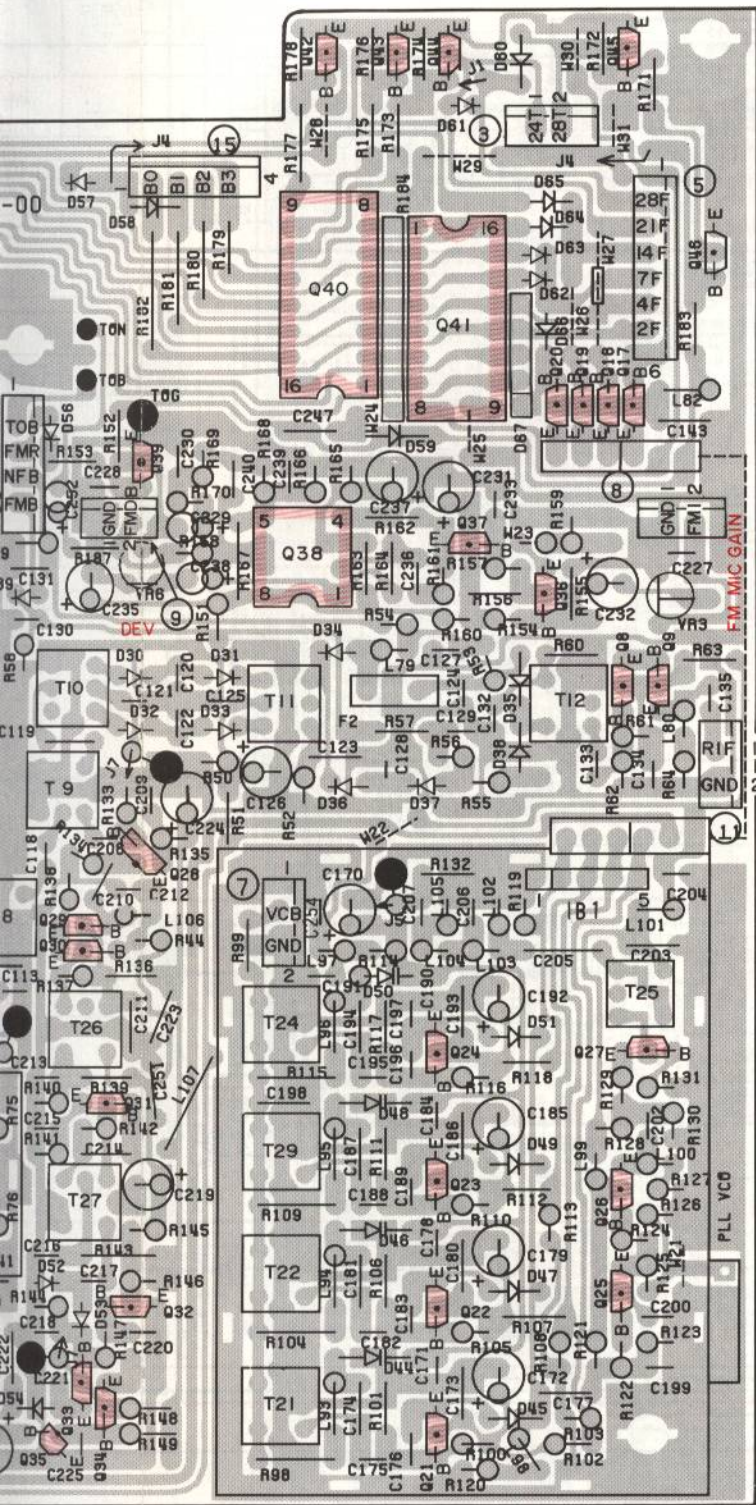

- 31: 2SC2668(Y),
 Y), Q27: 2SC2053,
 74LS145P or SN74LS145N
 , 11, 13, 15, 17, 19,
 : MA858,
 N401, D68: US1090,

2SC2538
 2SC2053

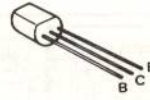

2SC1959 (Y)
 2SA562 (Y)

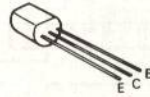

DTC124ES

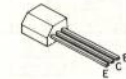

2SC2459 (BL)
 2SC2668 (Y)
 2SC2603 (E)
 DTC143TS

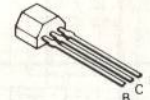

2SC2570A

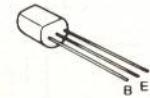

2SK125-5

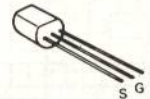

3SK74 (L)
 3SK122 (L)



2SK192A (GR)

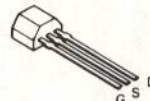

F

G

H

I

J

RF UNIT (X44-1680-00)

RF UNIT (X44-1680-00)

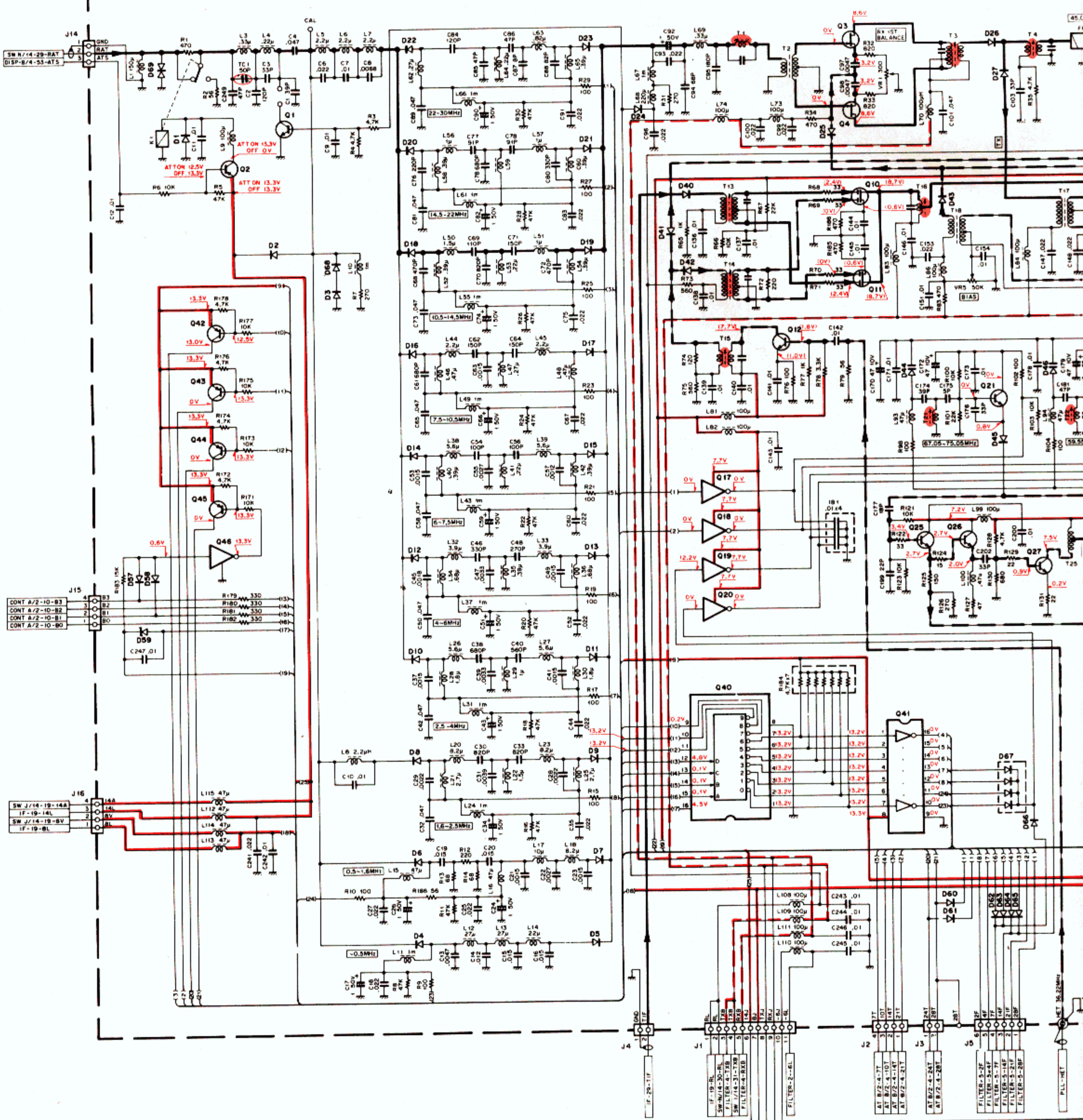

K

A

B

C

D

E

F

DISPLAY UNIT (X54-1870-00) Component side view

(00-0887-2AX) UNIT

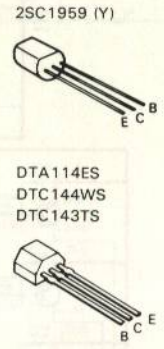
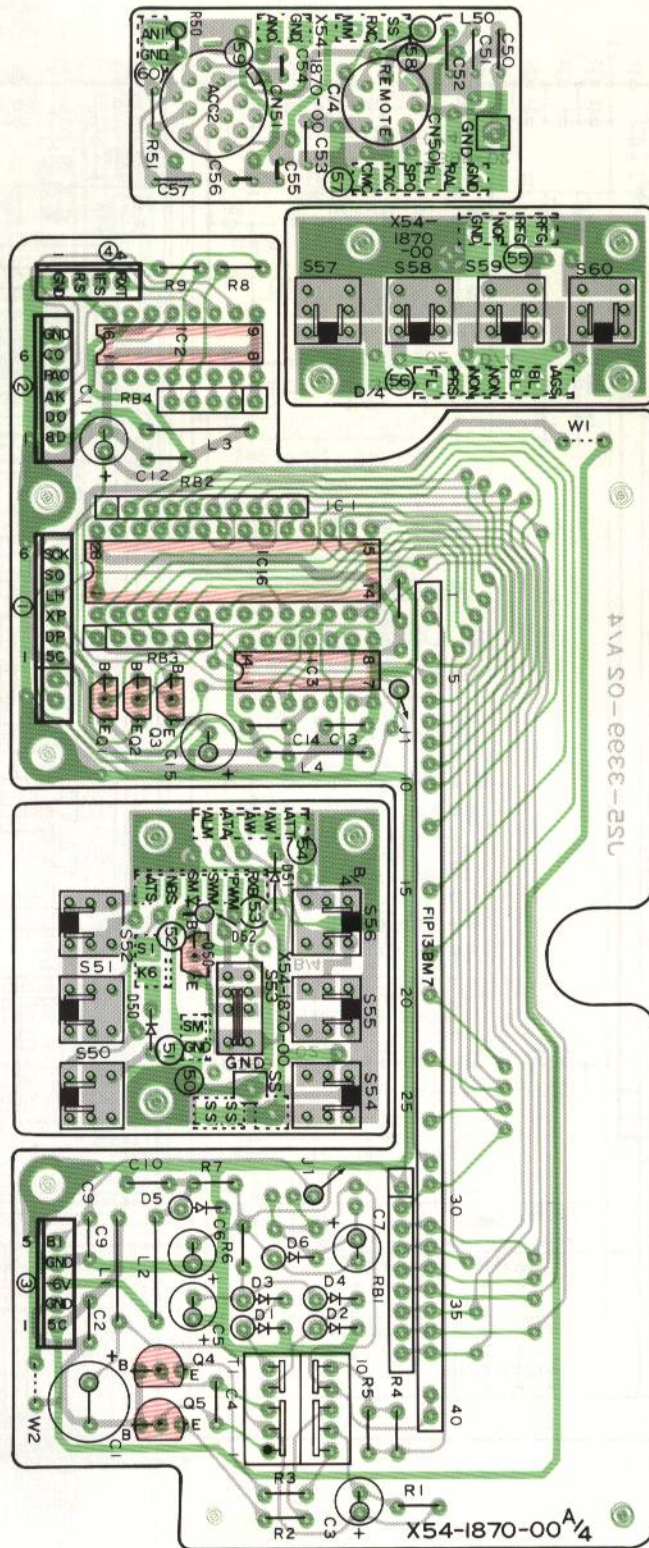

IC1: μ PD6300C, IC2: MB4052, IC3: TC4013BP, Q1, 2: DTA114ES, Q3: DTC114WS, Q4, 5: 2SC1959 (Y), Q50: DTC143TS, D1~4: 1S1555, D5, 6: MTZ6.2JA, D50, 51: 1SS133, D52: 1SS101

CONTROL UNIT (X53-1450-00, 11, 12) Component side view

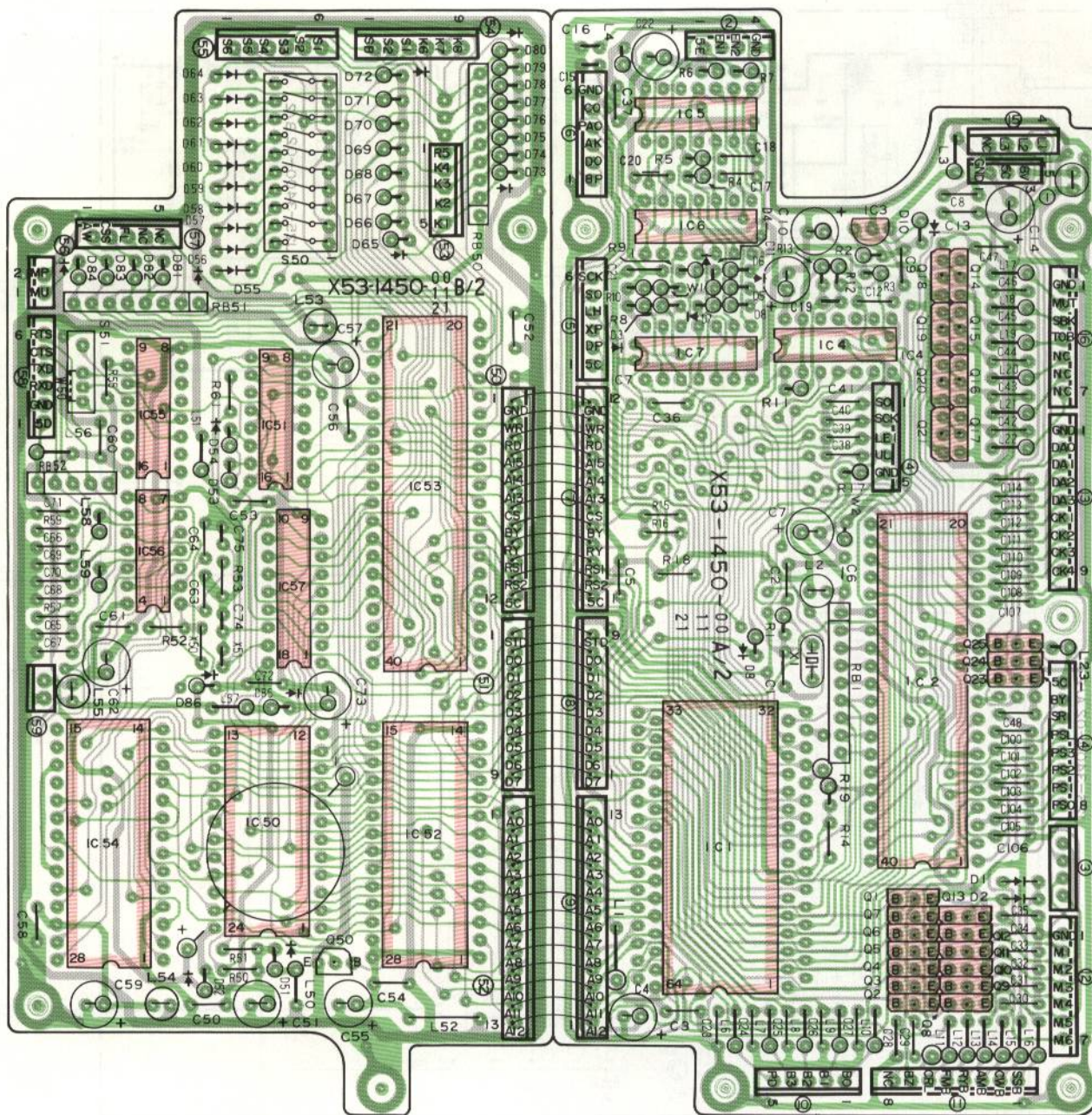

DTC144WS
DTA114ES

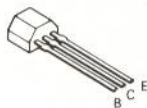

IC1: μ PD7800G, IC2, 53: TMP8225AP-5 or μ PD8255AC-5, IC3: PST520D, IC4: TC4069UB, IC5, 7: TC4011BP, IC6: TC4030BP, IC20: MB8418-20LP-GRA, IC51: SN74LS138N, IC52: MBM27128-25JA1, IC56: SN7404N, Q1-7, 14, 50: DTC144WS, Q8-13, 18-24, 25: DTA114ES, D1, 2, 5-9, 51-71, 73, 75, 82-84: 1SS133, D81: 1SS101

CONTROL UNIT (X53-1450-00)

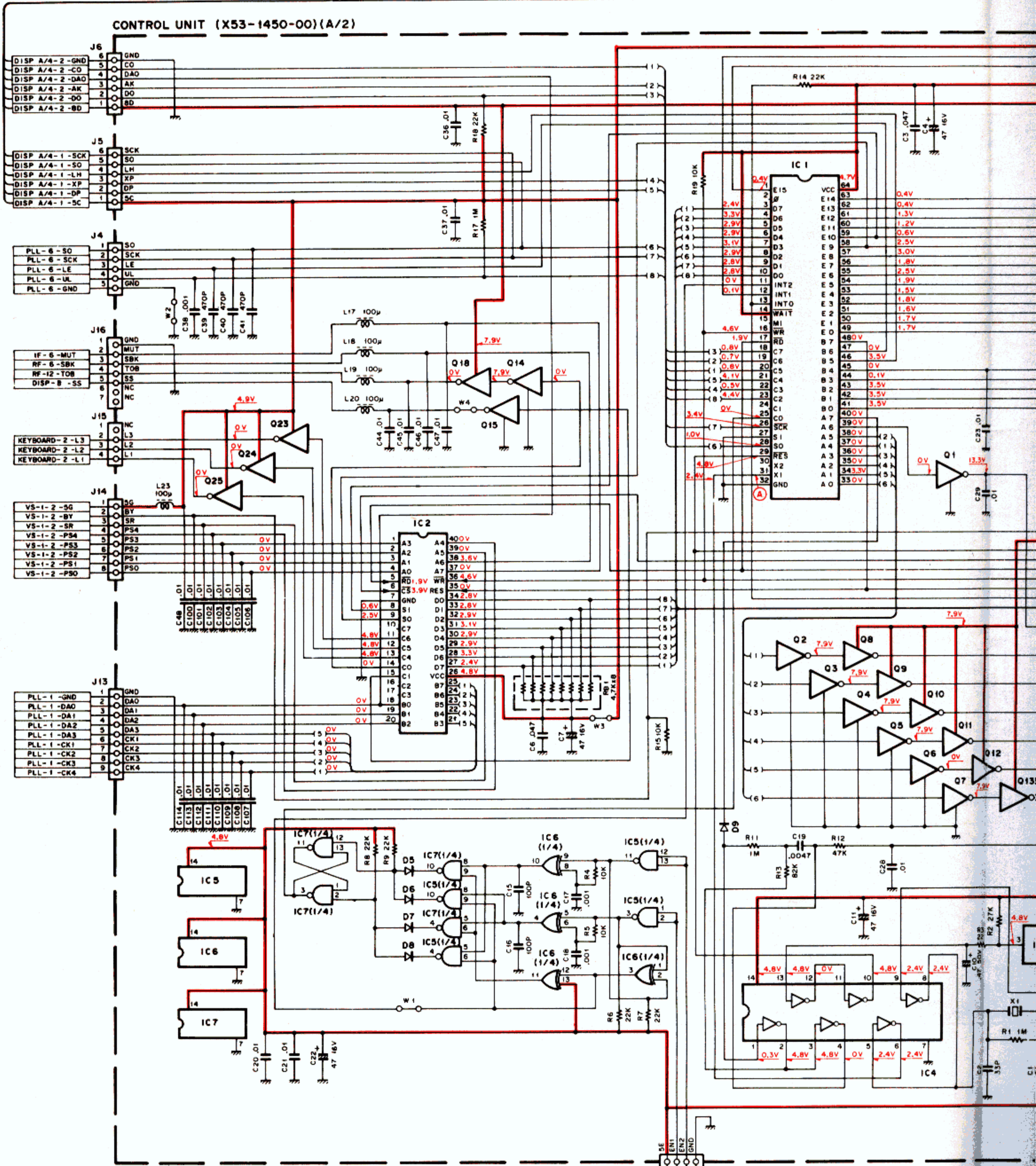

- | | | | |
|------|----------------------------|-------------------|------------|
| IC 1 | : μPD7800G | Q 1-7, 14, 15 | : DTC144WS |
| IC 2 | : TMP8255AP-5orμPDB255AC-5 | Q 8-13, 18, 23-25 | : DTA114ES |
| IC 3 | : PST520D | D 1, 2, 5-9 | : ISS133 |
| IC 4 | : TC4069UBP | | |
| IC 5 | : TC4011BP | | |
| IC 6 | : TC4030BP | | |

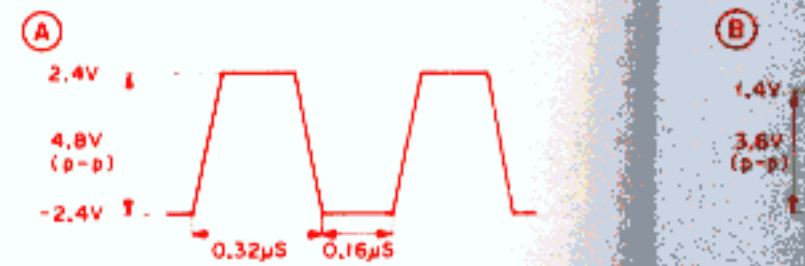

DISPLAY UNIT (X54-1870-00) A/4

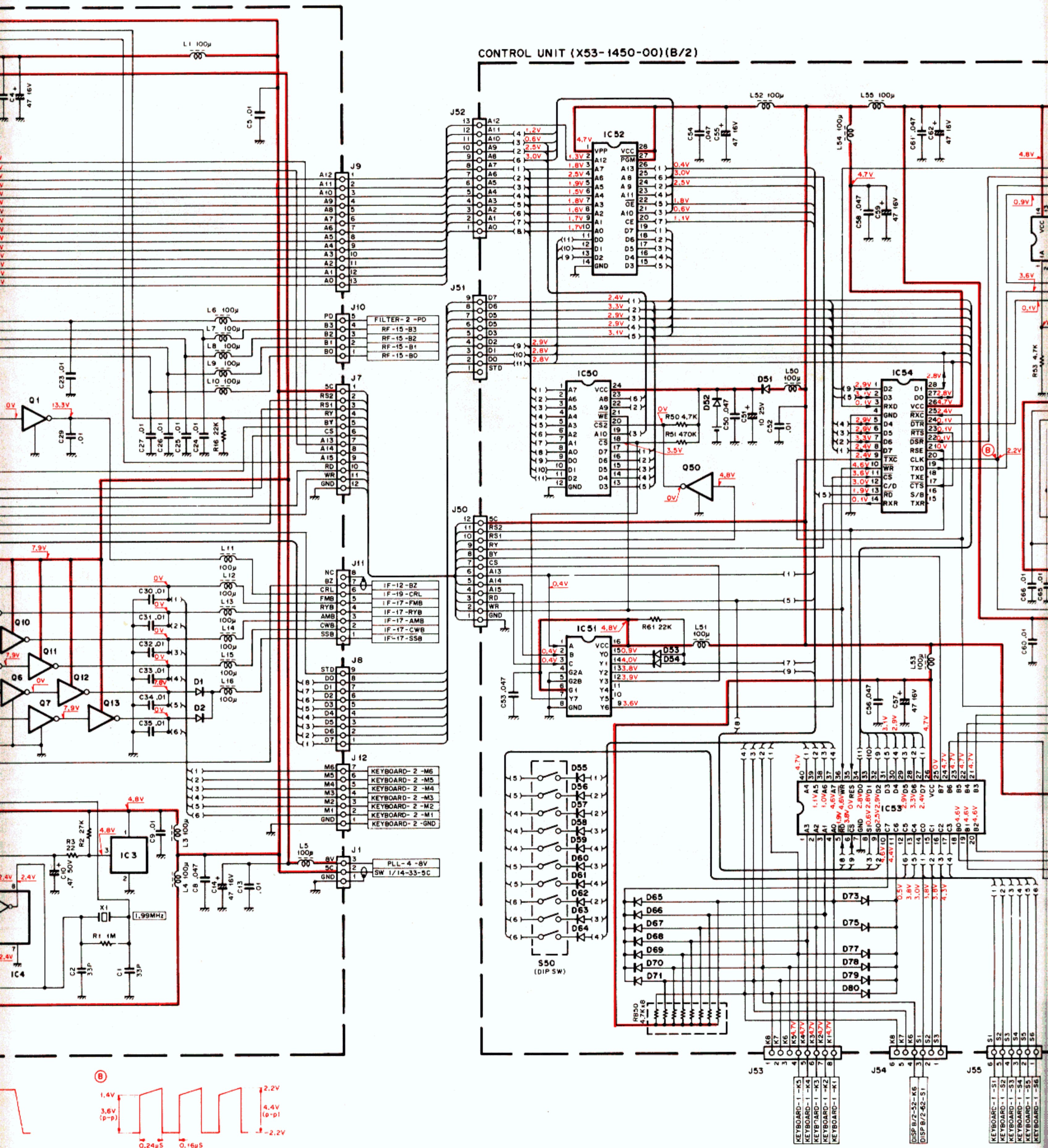

CIRCUIT DIAGRAM TS-440S

Refer to Schematic diagram on page 113.

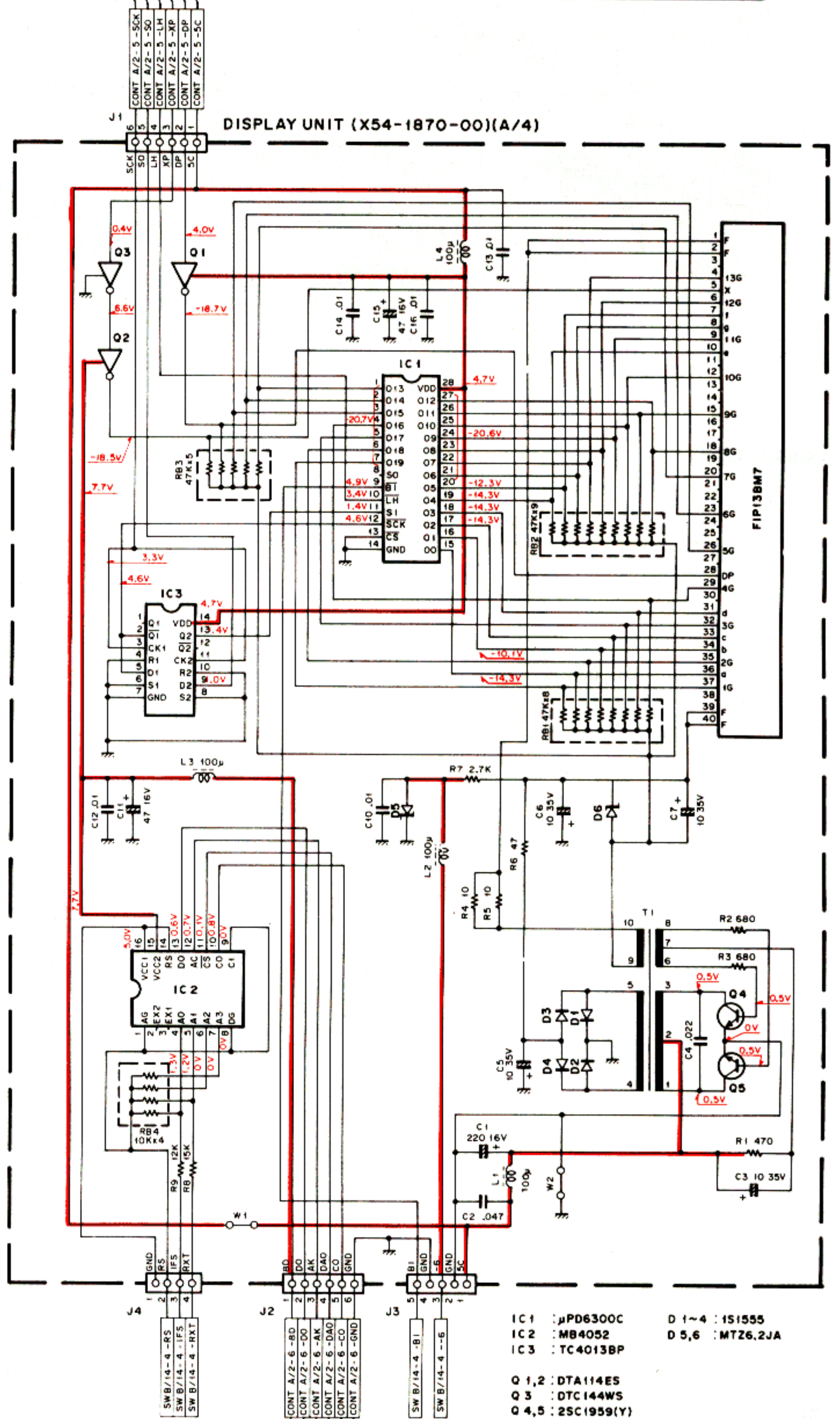
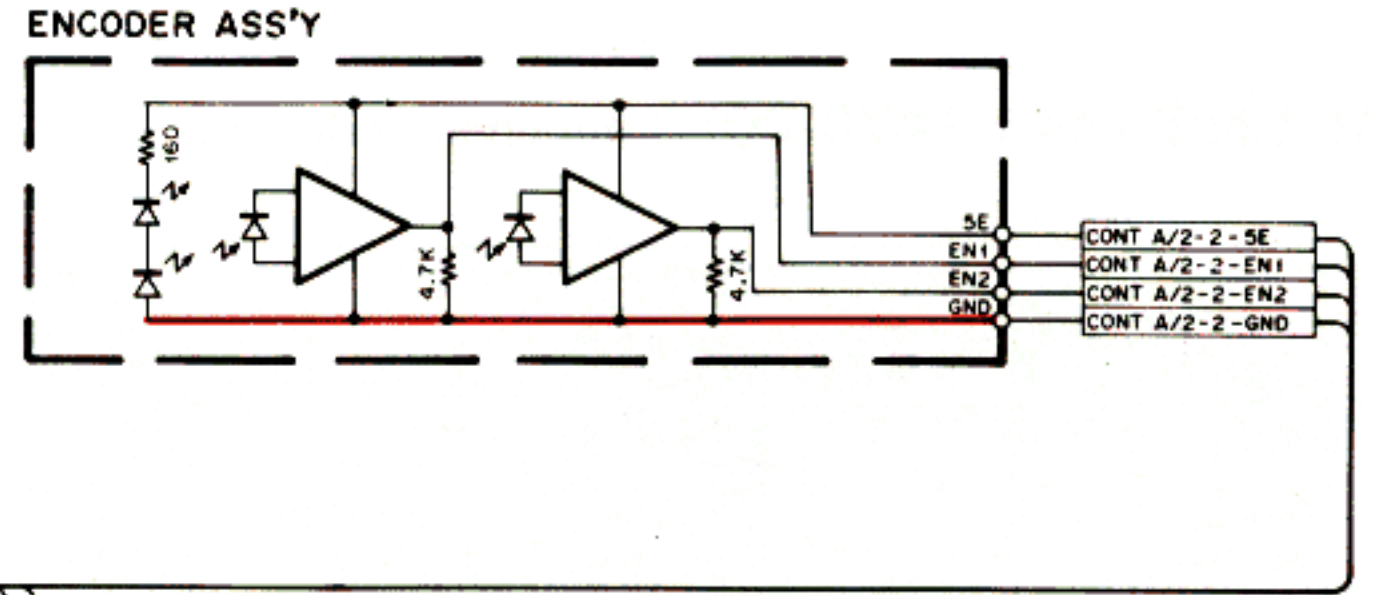
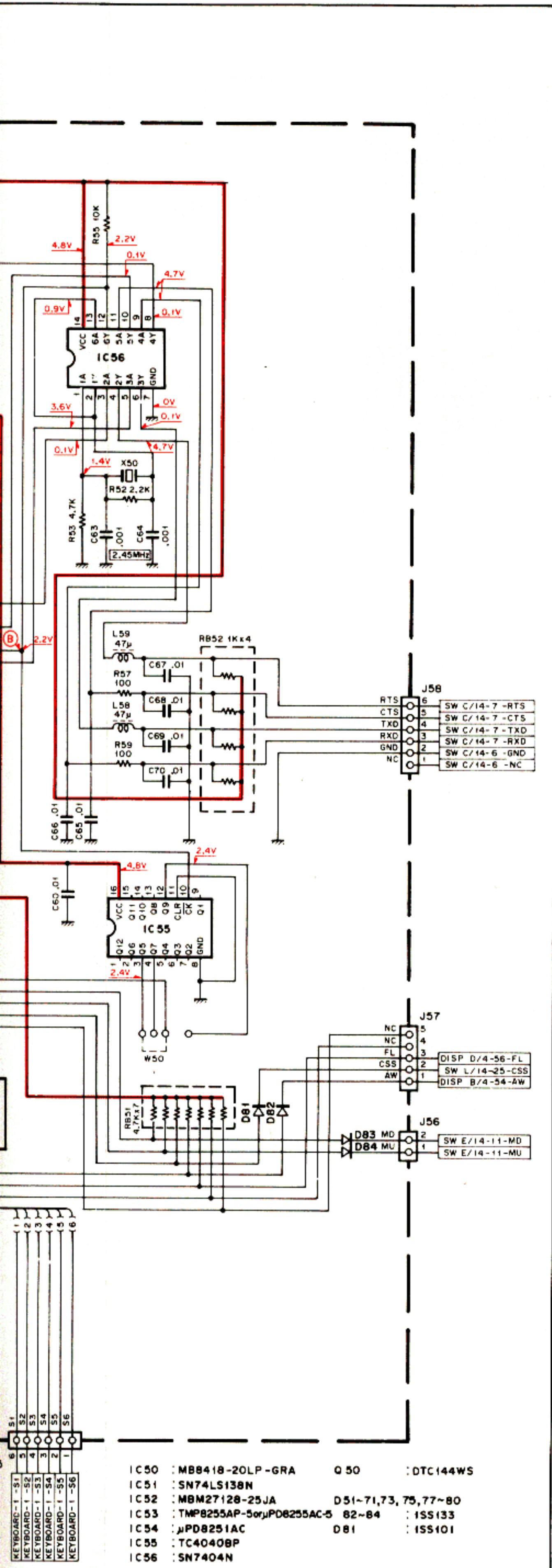

- IC50 : MB8418-20LP-GRA Q 50 : DTC144WS
- IC51 : SN74LS138N
- IC52 : MBM27128-25JA D51-71,73, 75,77-80
- IC53 : TMP8255AP-5orµPD8255AC-5 82-84 : ISS133
- IC54 : µPD8251AC D81 : ISS101
- IC55 : TC4040BP
- IC56 : SN7404N

- IC1 : µPD6300C D 1~4 : 1S1555
- IC2 : MB4052 D 5,6 : MTZ6.2JA
- IC3 : TC4013BP
- Q 1,2 : DTA114ES
- Q 3 : DTC144WS
- Q 4,5 : 2SC1959(Y)

The voltages measured when receiving 14MHz, USB

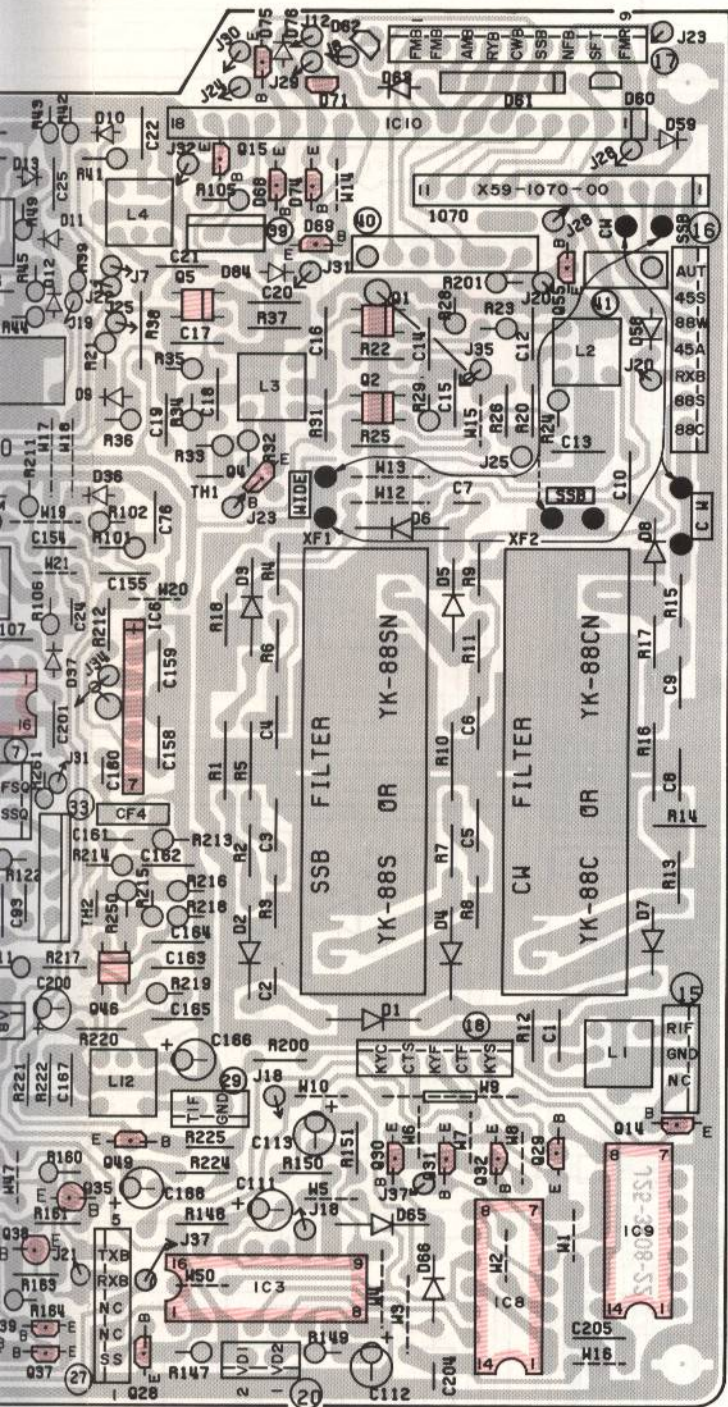

2SA562TM

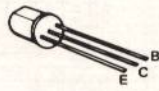

2SC2458 (Y)
2SC2459 (Y)
2SA1048 (Y)
DTC114ES
DTC143TS

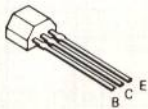

2SK30A (O)

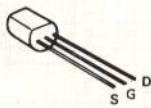

3SK73 (GR)

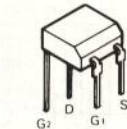

2SK192 (GR)

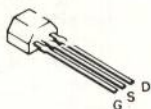

8,
54: 2SC2458
4, 29-32,
A562TM
63, 76-80,
1JB,

TS-440S PC BOARD VIEW

IF UNIT (X60-1300-00) Component side view

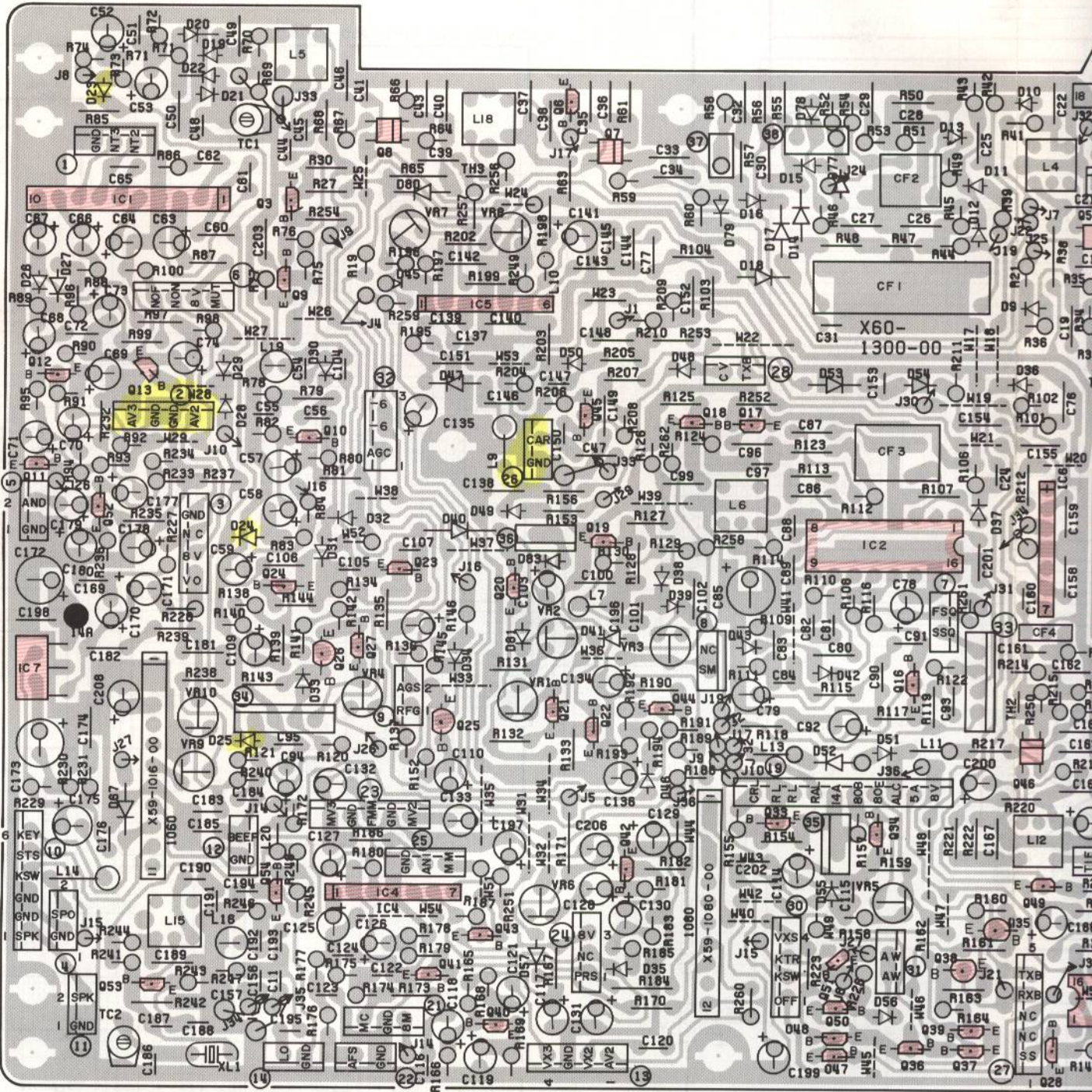

IC1: BX7191, IC2: MC3357P, IC3: M74LS123P or SN74LS123N, IC4: μ PC1158H2, IC5, 6: AN612, IC7: μ PC2002V, IC8, 9: M74LS00P or SN74LS00N, IC10: BX6124, Q1, 2, 5, 7, 8, 46: 3SK73(GR), Q3, 9, 17, 19, 23, 24, 34, 42, 45, 53, 54: 2SC2458 (Y), Q4, 6, 11, 13, 15, 22, 28, 36, 37, 39, 41, 43, 50, 55: DTC 114ES, Q10, 12, 16, 40, 44, 52: 2SC2459 (BL), Q14, 29-32, 47, 48, 51: DTC 143TS, Q18, 21, 27, 49: 2SA1048 (Y), Q20: 2SK192 (GR), Q25, 26: 2SK30A (O), Q33, 35, 38: 2SA562TM D1-6: 1S1007, D7, 8, 10, 12-18, 36, 50, 53, 54: 1S1587, D9, 11, 23-29, 31-34, 41, 45, 46, 48, 49, 56-59, 63, 76-80, 82-84: 1SS133, D19-22, 30, 35, 39, 42, 43: 1N60, D37, 38, 40, 65, 66, 81: 1S1555, D47: MI 204, D51: MTZ9.1JB, D52: V06B, D55: MTZ6.2JA, D60, 62, 68-72, 74, 75: MC921, D61: DAN401, D67: 1SS101

FINAL UNIT (X45-1470-00) Component side view

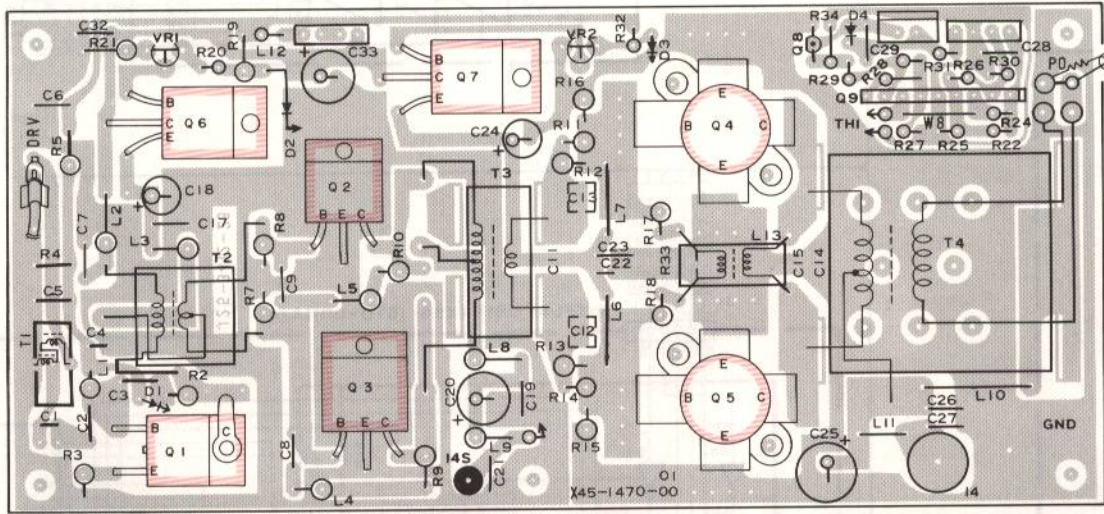

2SC1815 (Y)

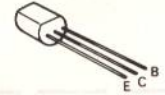

2SC2075

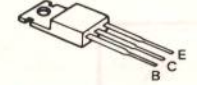

2SD1406 (Y)

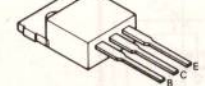

2SC2879

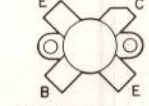

2SC2509



Q1: 2SC2075, Q2, 3: 2SC2509, Q4, 5: 2SC2879, Q6, 7: 2SD1406 (Y), Q8: 2SC1815 (Y), Q9: AN6551, D1: MV-5T, D2, 3: SV03YS, D4: 1SS133 or 1S1555.

FINAL UNIT

Refer to Schematic diagram on page 113.

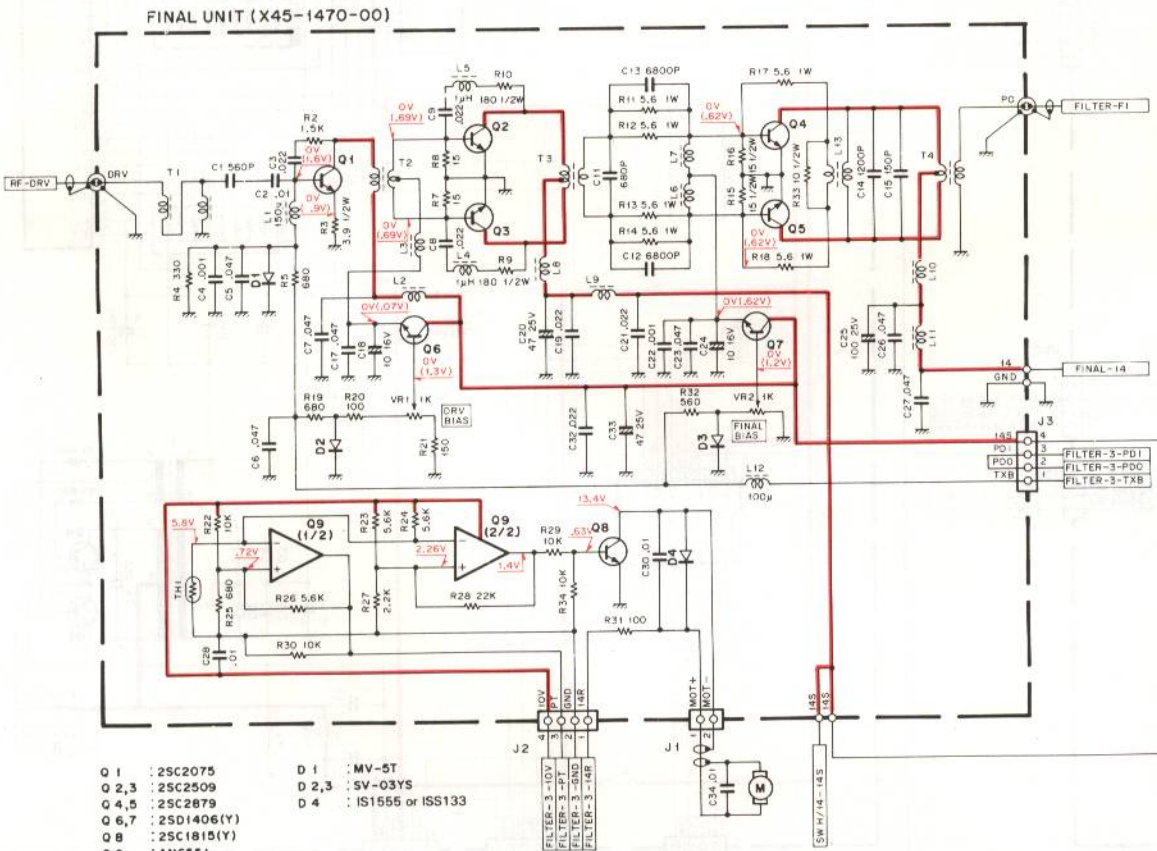

- | | | | |
|--------|--------------|--------|--------------------|
| Q 1 | : 2SC2075 | D 1 | : MV-5T |
| Q 2, 3 | : 2SC2509 | D 2, 3 | : SV-03YS |
| Q 4, 5 | : 2SC2879 | D 4 | : 1S1555 or 1SS133 |
| Q 6, 7 | : 2SD1406(Y) | | |
| Q 8 | : 2SC1815(Y) | | |
| Q 9 | : AN6551 | | |

IF UNIT (X60-1300-00)

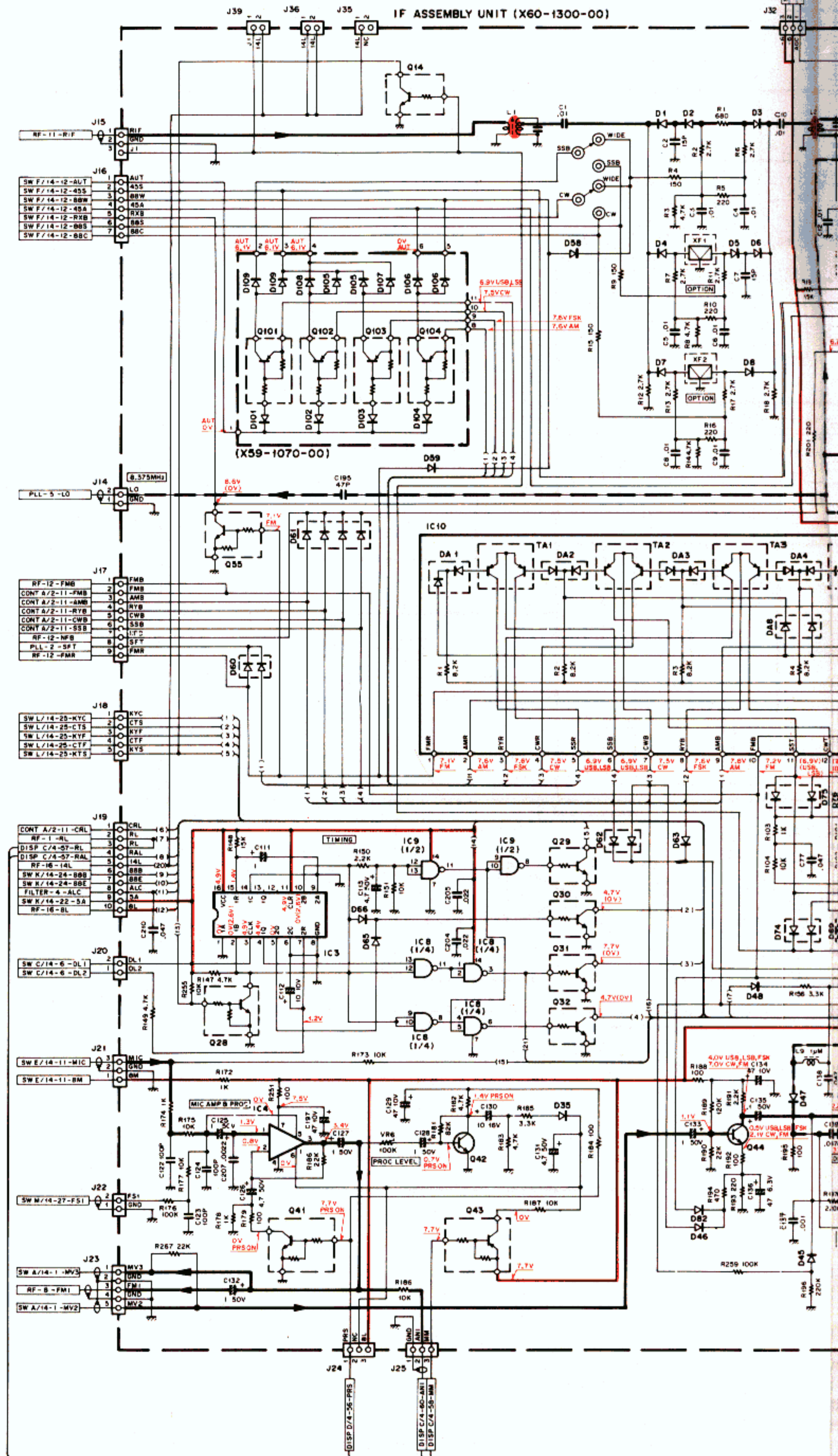

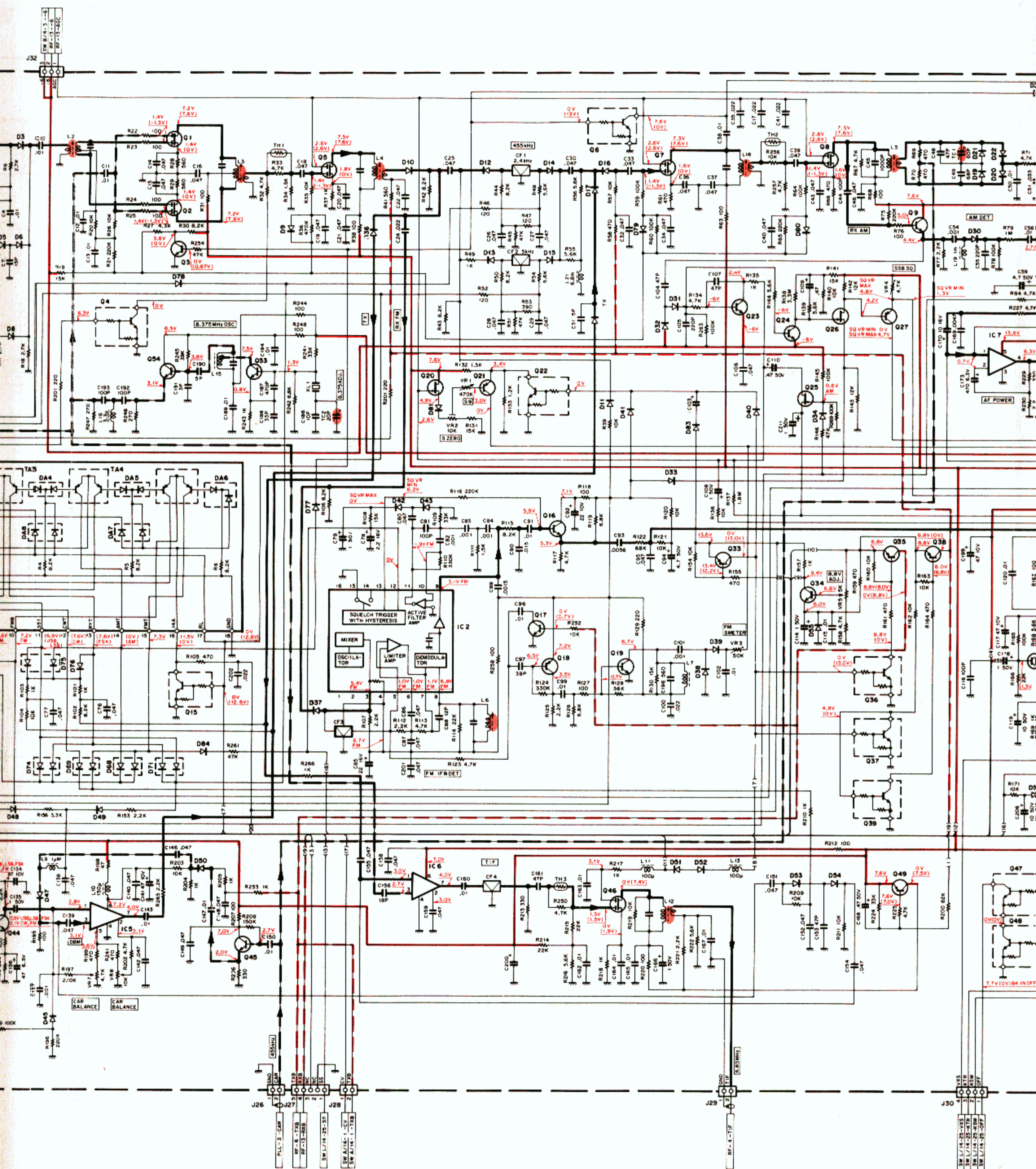

G

H

I

J

K

Refer to Schematic diagram on page 113.

The voltages measured when receiving 14.1 MHz, LSB, () in TX

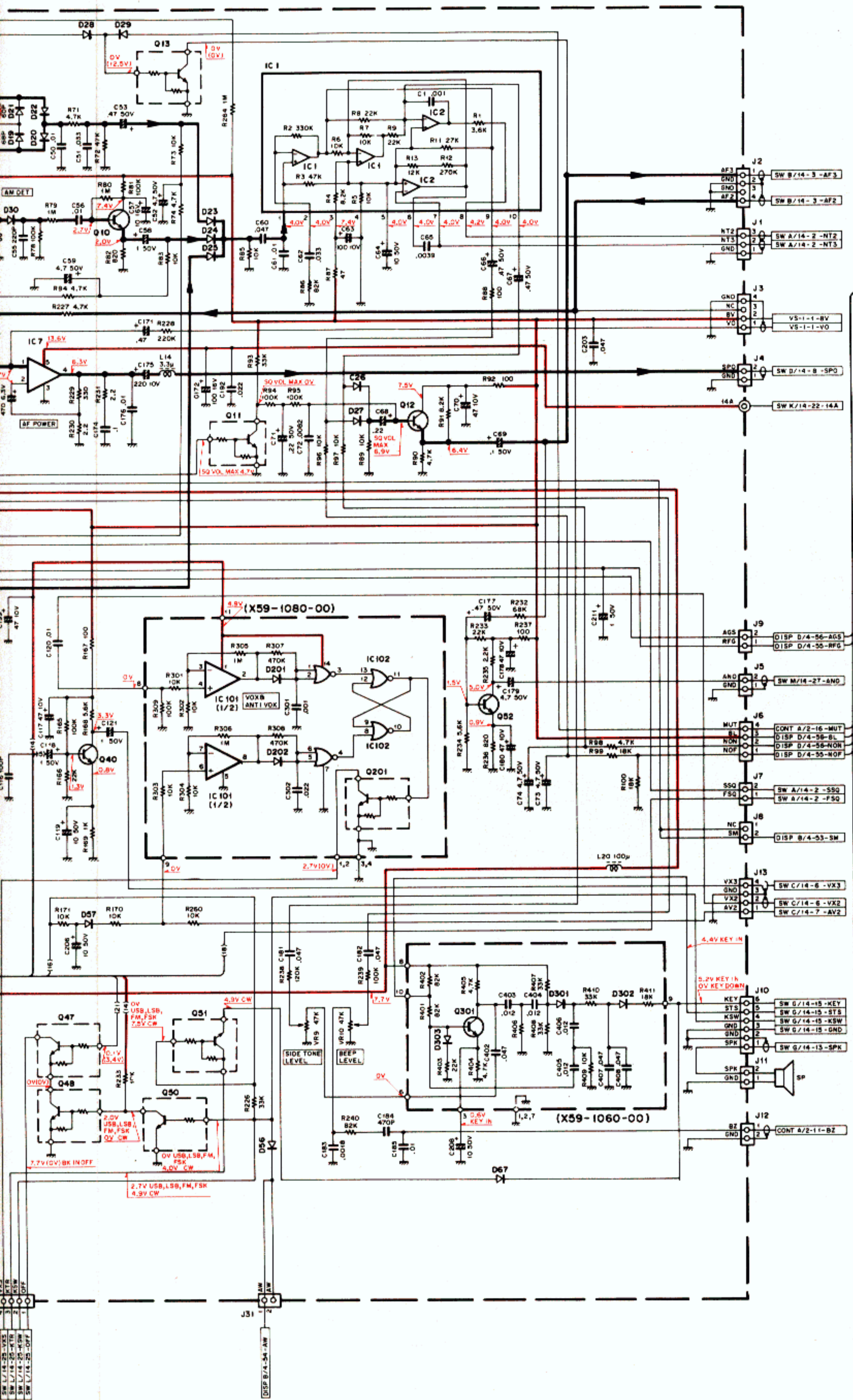

DISPLAY UNIT (X54-1870-00)(D/4)

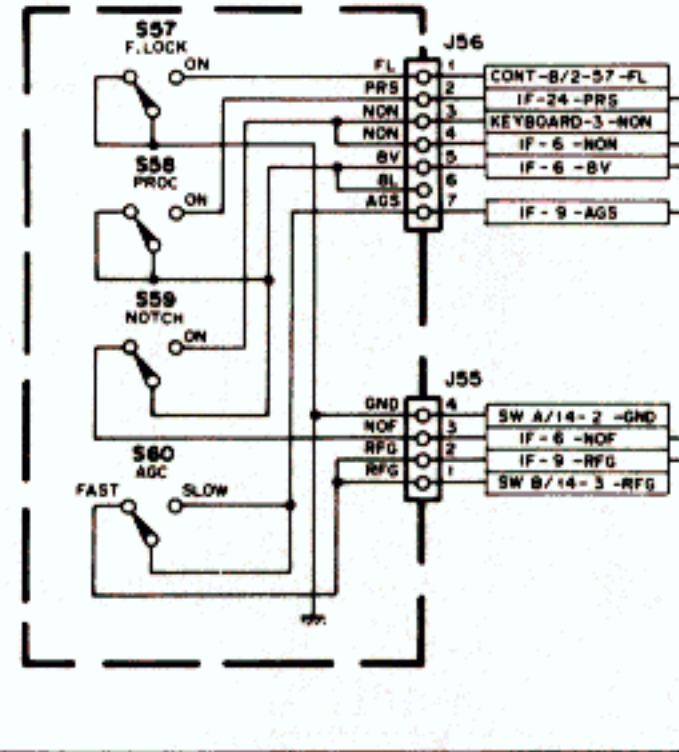

DISPLAY UNIT (X54-1870-00)(C/4)

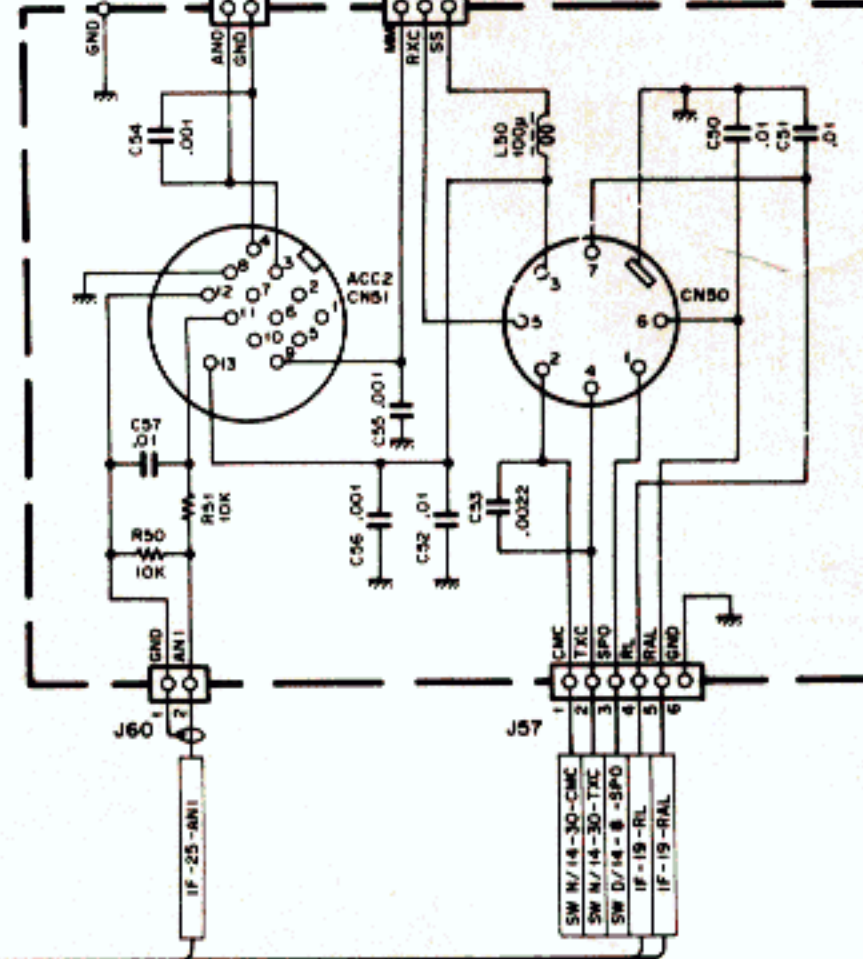

- | | |
|---|------------------|
| IC 1 | : BX7191 |
| IC 2 | : MC3357 |
| IC 3 | : 74LS123 |
| IC 4 | : μ PC1158HZ |
| IC 5, 6 | : AN512 |
| IC 7 | : μ PC2002V |
| IC 8, 9 | : 74LS00 |
| IC 10 | : BX6124 |
| Q 1, 2, 5, 7, 8, 46 | : 3SK73(GR) |
| Q 3, 9, 17, 19, 23, 24, 34, 42, 45, 53, 54 | : 2SC2458(Y) |
| Q 4, 6, 11, 13, 15, 22, 26, 36, 37, 39, 41, 50, 55 | : DTC114ES |
| Q 10, 12, 16, 40, 44, 52 | : 2SC2459(BL) |
| Q 14, 29-32, 47, 48, 51 | : DTC143TS |
| Q 18, 21, 27, 49 | : 2SA1048(Y) |
| Q 20 | : 2SK192(GR) |
| Q 25, 26 | : 2SK30A(O) |
| Q 33, 35, 38 | : 2SA562(Y) |
| Q 43 | : DTA114ES |
| D 1-6 | : 1S1007 |
| D 7, 8, 10, 12-18, 36, 50, 53, 54 | : 1S1587 |
| D 9, 11, 23-29, 31-34, 41, 45, 46, 48, 49, 56, 59, 63, 76-80, 82-84 | : 1S5133 |
| D 19-22, 30, 35, 39, 42, 43 | : 1N60 |
| D 37, 38, 40, 65, 66, 81 | : 1S1855 |
| D 47 | : M1204 |
| D 51 | : MT29.1JB |
| D 52 | : V068 |
| D 55 | : MT26.2JA |
| D 60, 62, 66, 69, 71, 74, 75 | : MC921 |
| D 61 | : DAN401 |
| D 67 | : 1S5101 |
| TH 1, 2 | : 112-502-2 |
| TH 3 | : 32D27 |
| X59-1060-00 | |
| Q301 | : 2SC2712(Y) |
| D301 | |
| X59-1070-00 | |
| Q101-104 | : DTA114ES |
| X59-1080-00 | |
| IC 101 | : NJM2904M |
| IC 102 | : TC4001 |
| Q201 | : DTC114ES |

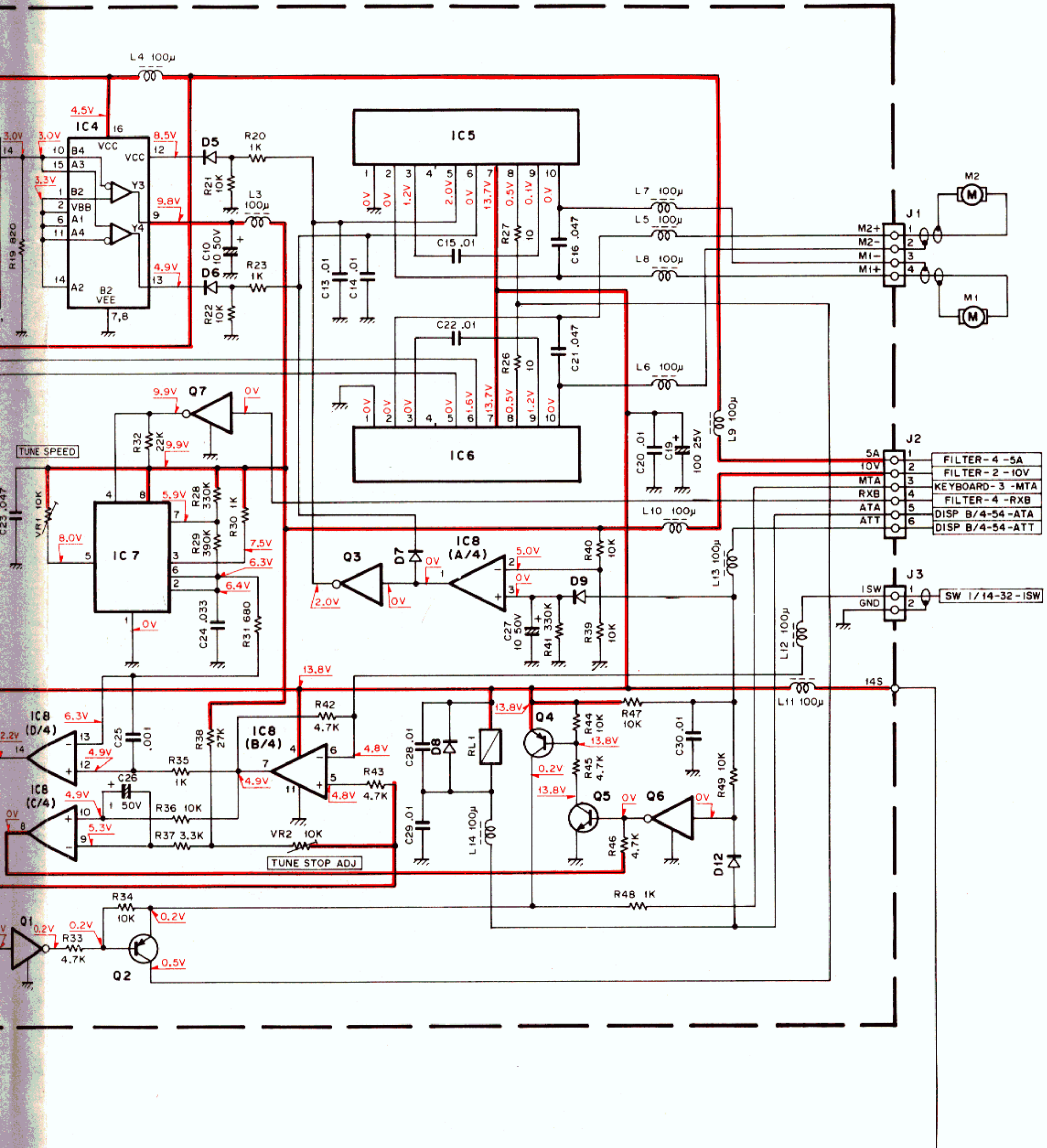

15599
 UZ-6.2BL
 155133
 5: 151555
 1N60

TS-440S CIRCUIT DIAGRAM

AT UNIT (X57-1150-00)

AT UNIT (X57-1150-00) (A/2)

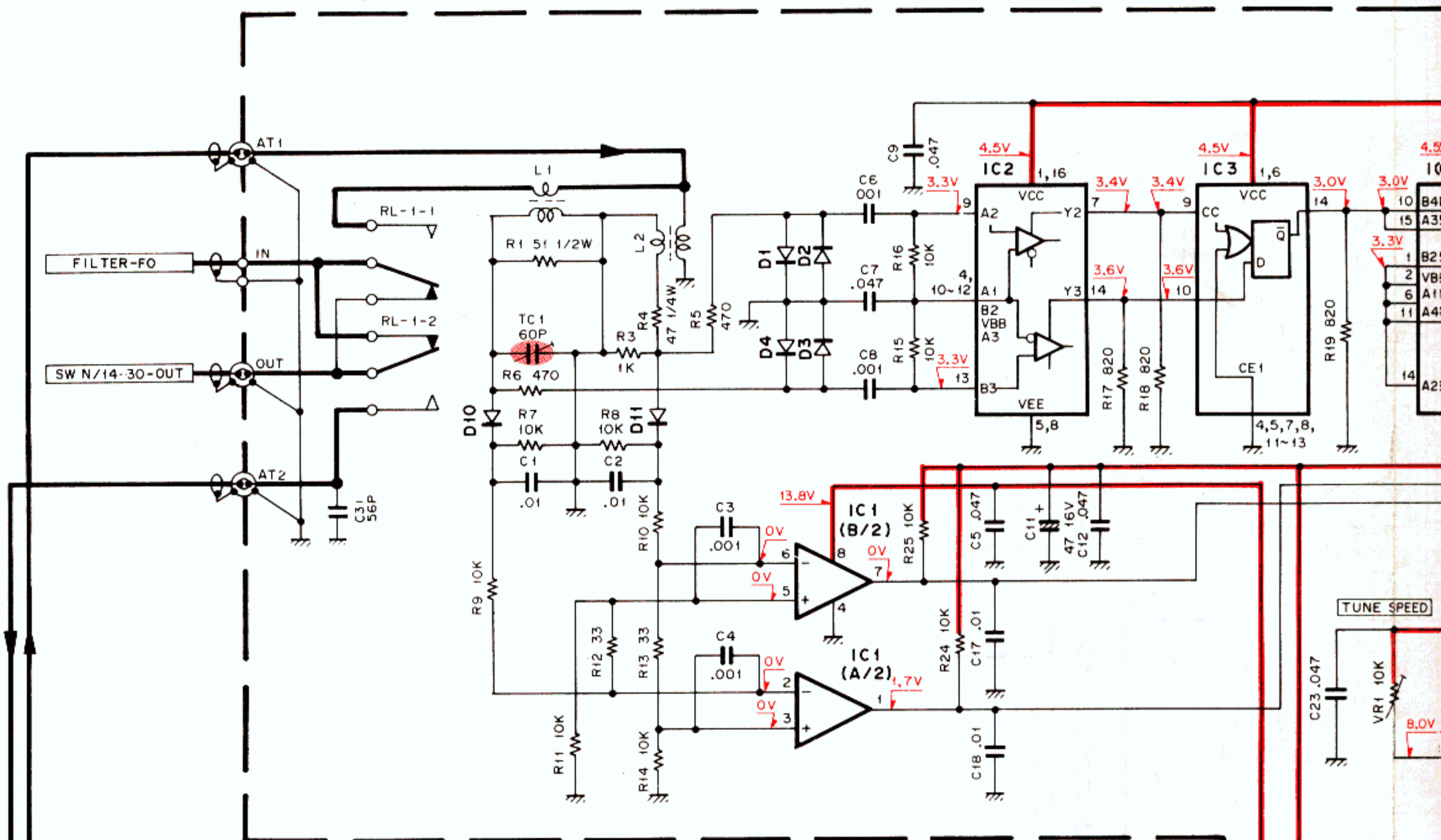

AT UNIT (X57-1150-00) (B/2)

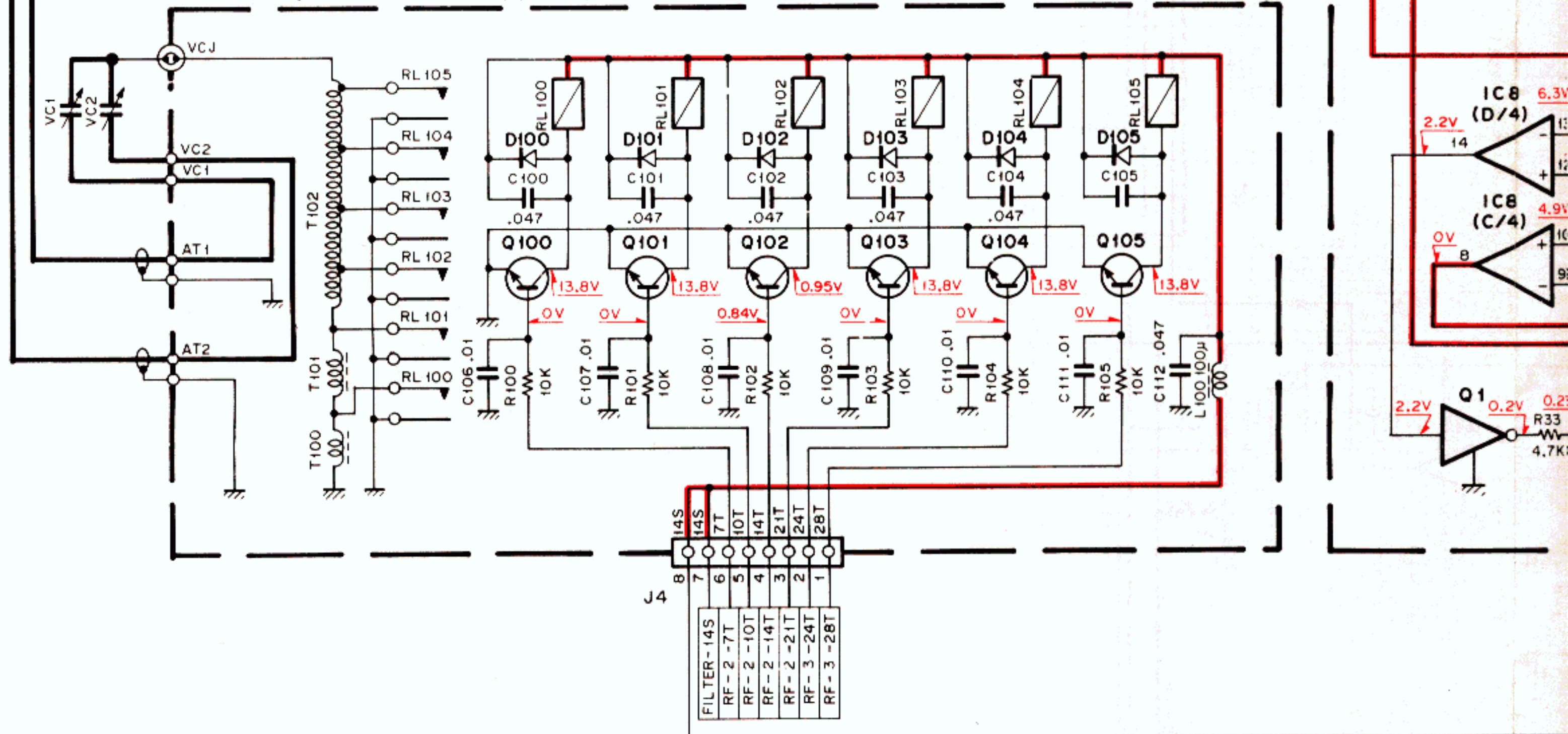

IC 1	: NJM2903D	Q 1,3,6	: DTC114ES	D 1~4	: 1SS99
IC 2	: HD10116	Q 2,9	: 2SA950(Y)	D 5,6	: UZ-6.2BL
IC 3	: HD10131	Q 5	: 2SC2458(Y)	D 7,9,12	: 1SS133
IC 4	: HD10125	Q 7	: DTC124ES	D 8,100-105	: 1S1555
IC 5,6	: BA6109U2	Q100-105	: 2SC2668(Y)	D 10,11	: 1N60
IC 7	: NE555P				
IC 8	: MB3614				

AT UNIT (X57-1150-00) Component side view

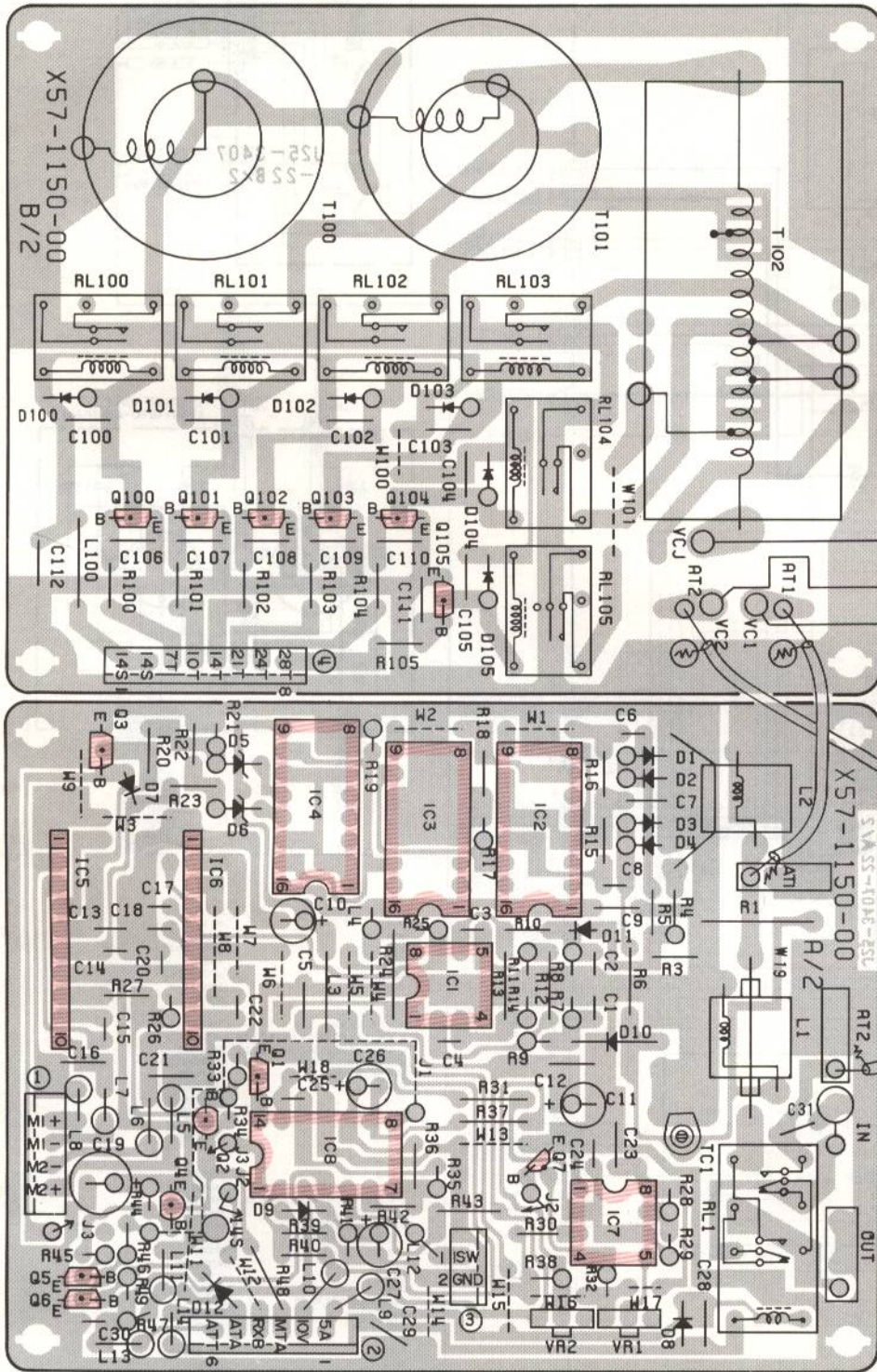

2SA950 (Y)

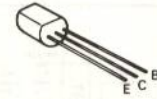

2SC2458 (Y)
2SC2668 (Y)

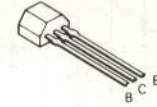

IC1: NJM2903D, IC2: HD10116 or MC10116L, IC3: HD10131 or MC10131L, IC4: HD10125 or MC10125L, IC5, 6: BA6109U2, IC7: NE555P, IC8: MB3614, Q1, 3, 6: DTC114ES, Q2, 4: 2SA950 (Y), Q5: 2SC2458 (Y), Q7: DTC124ES, Q100~105: 2SC2668 (Y), D1~4: 1SS99, D5, 6: UZ6.2BL, D7, 9, 12: 1SS133, D8, 100~105: 1N4448 or 1S1555, D10, 11: 1N60

DISASSEMBLY

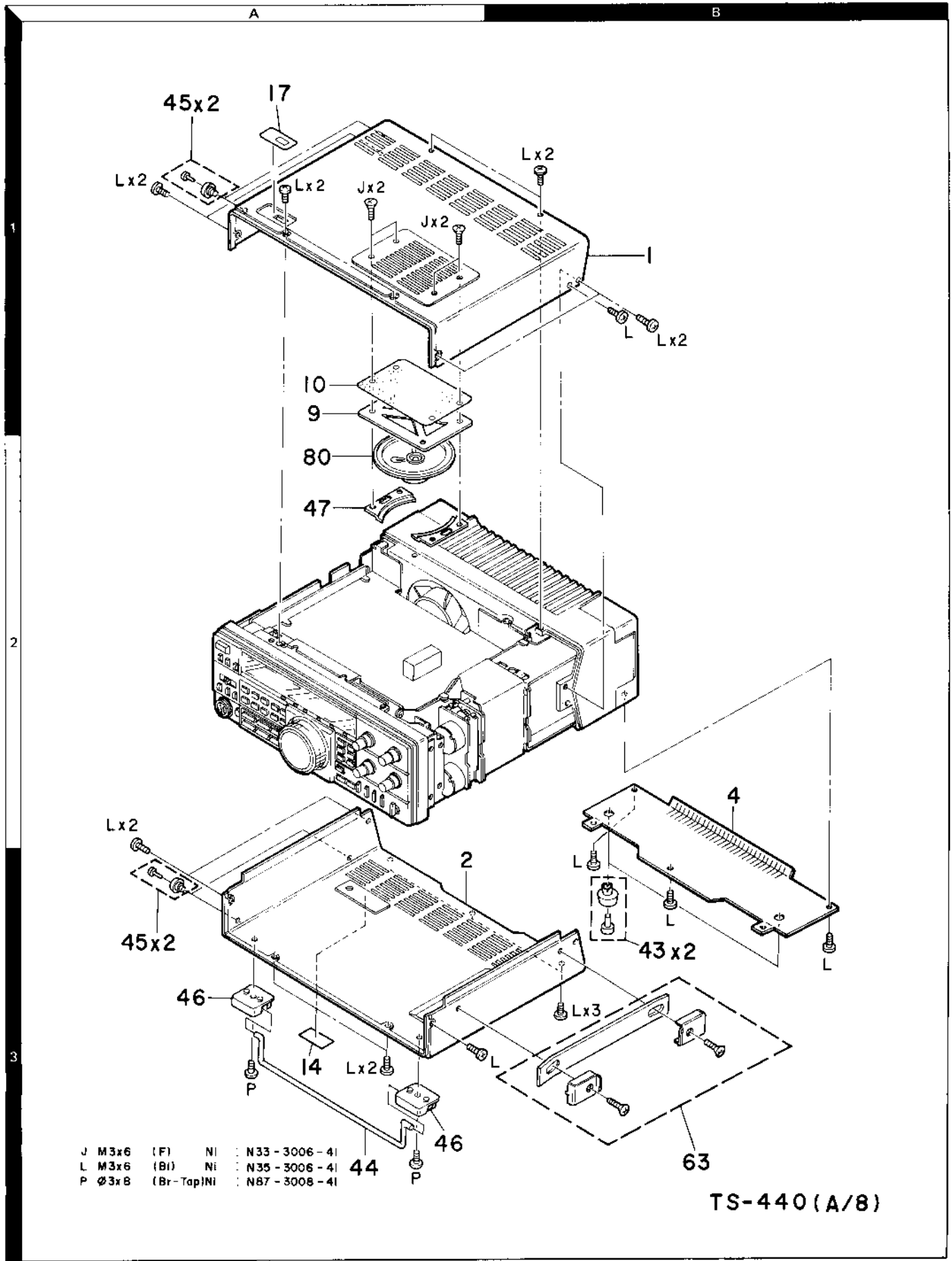

TS-440(A/8)

Parts with the exploded numbers larger than 700 are not supplied.

DISASSEMBLY

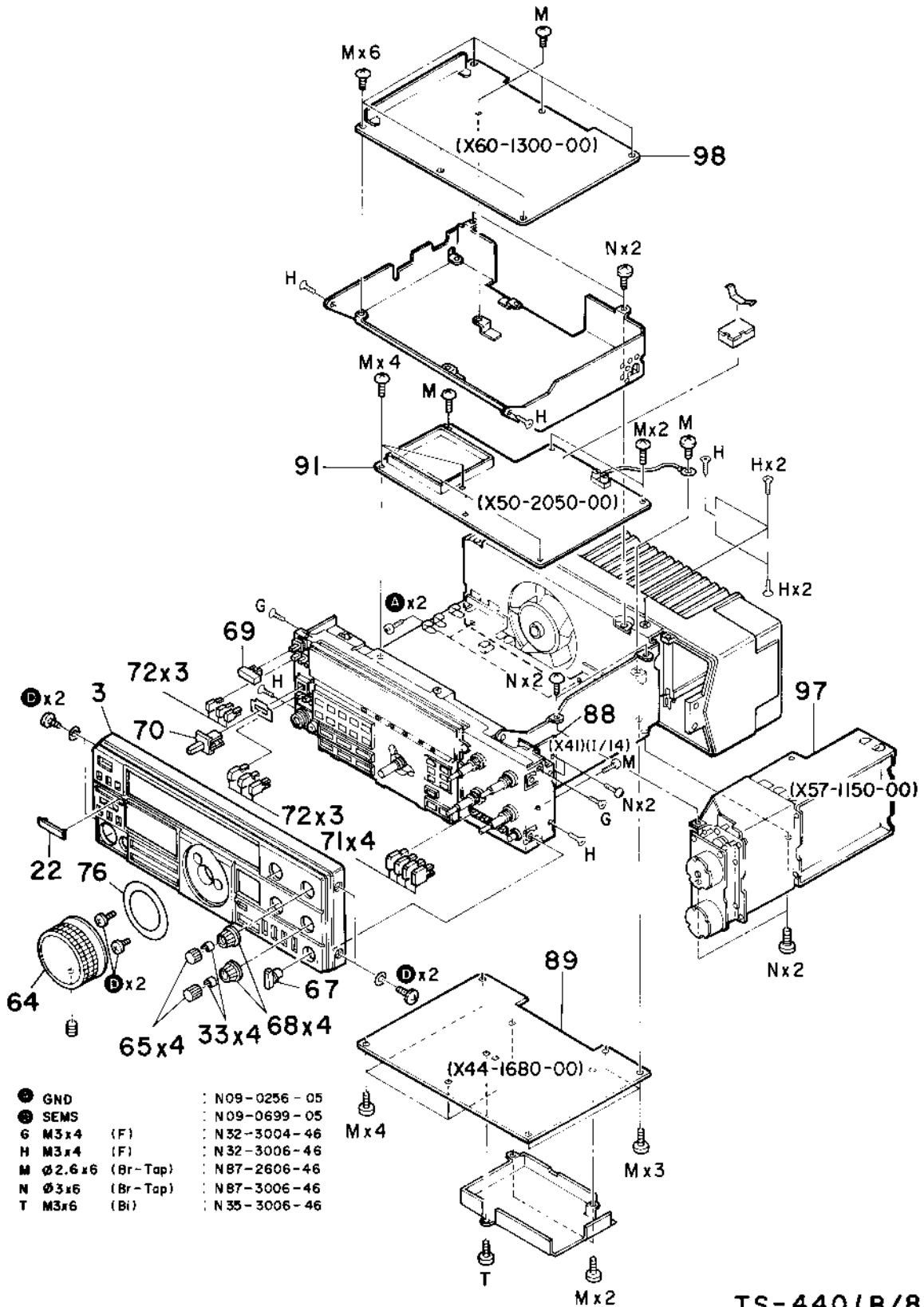

TS-440(B/8)

Parts with the exploded numbers larger than 700 are not supplied.

DISASSEMBLY

TS-440 (C/8)

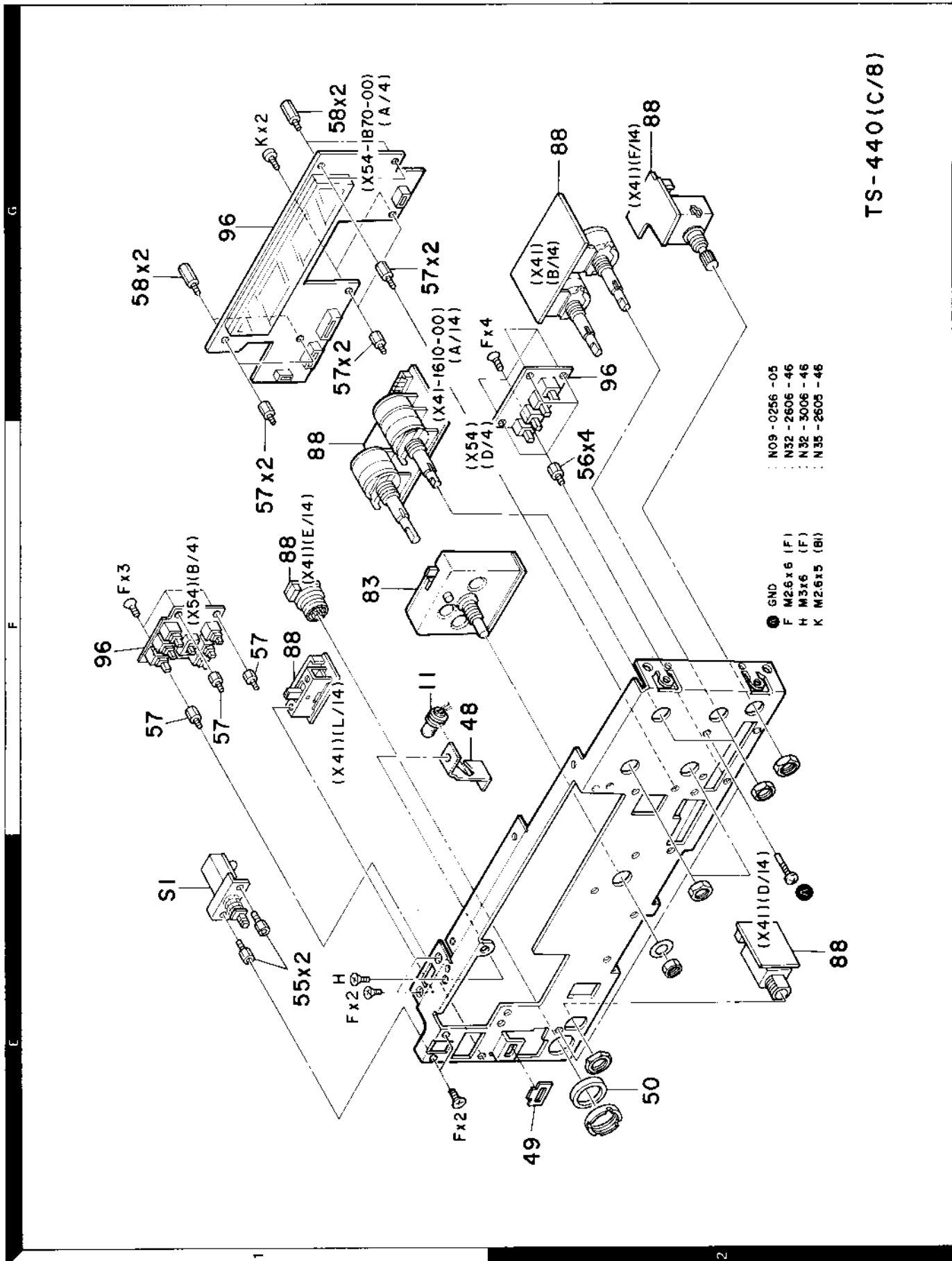

- N09-0256-05
- N32-2606-46
- N32-3006-46
- N35-2605-46

- GND
- F M2.6x6 (F)
- H M3x6 (F)
- K M2.6x5 (BI)

Parts with the exploded numbers larger than 700 are not supplied.

DISASSEMBLY

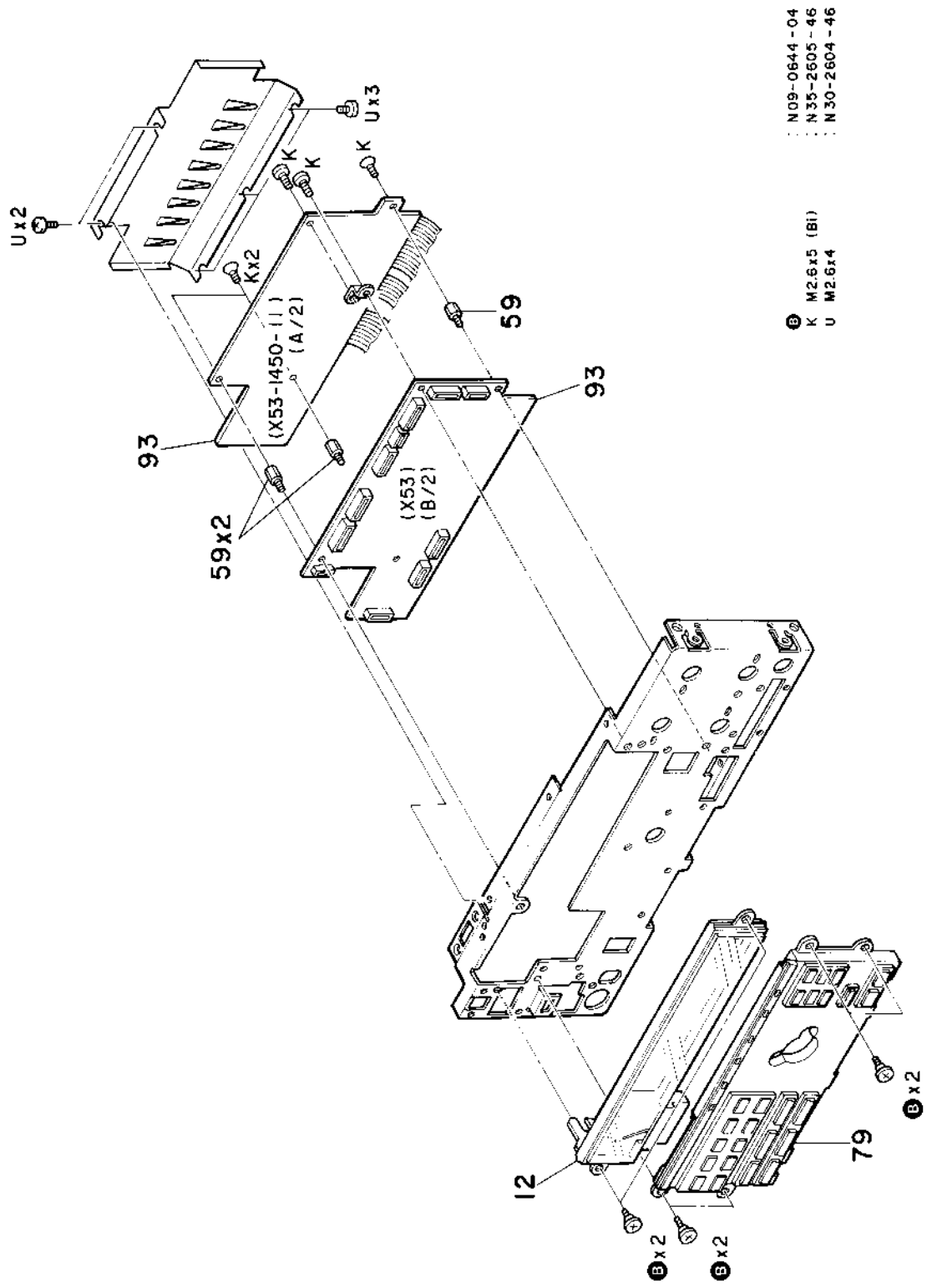

TS-440 (D/8)

Parts with the exploded numbers larger than 700 are not supplied.

DISASSEMBLY

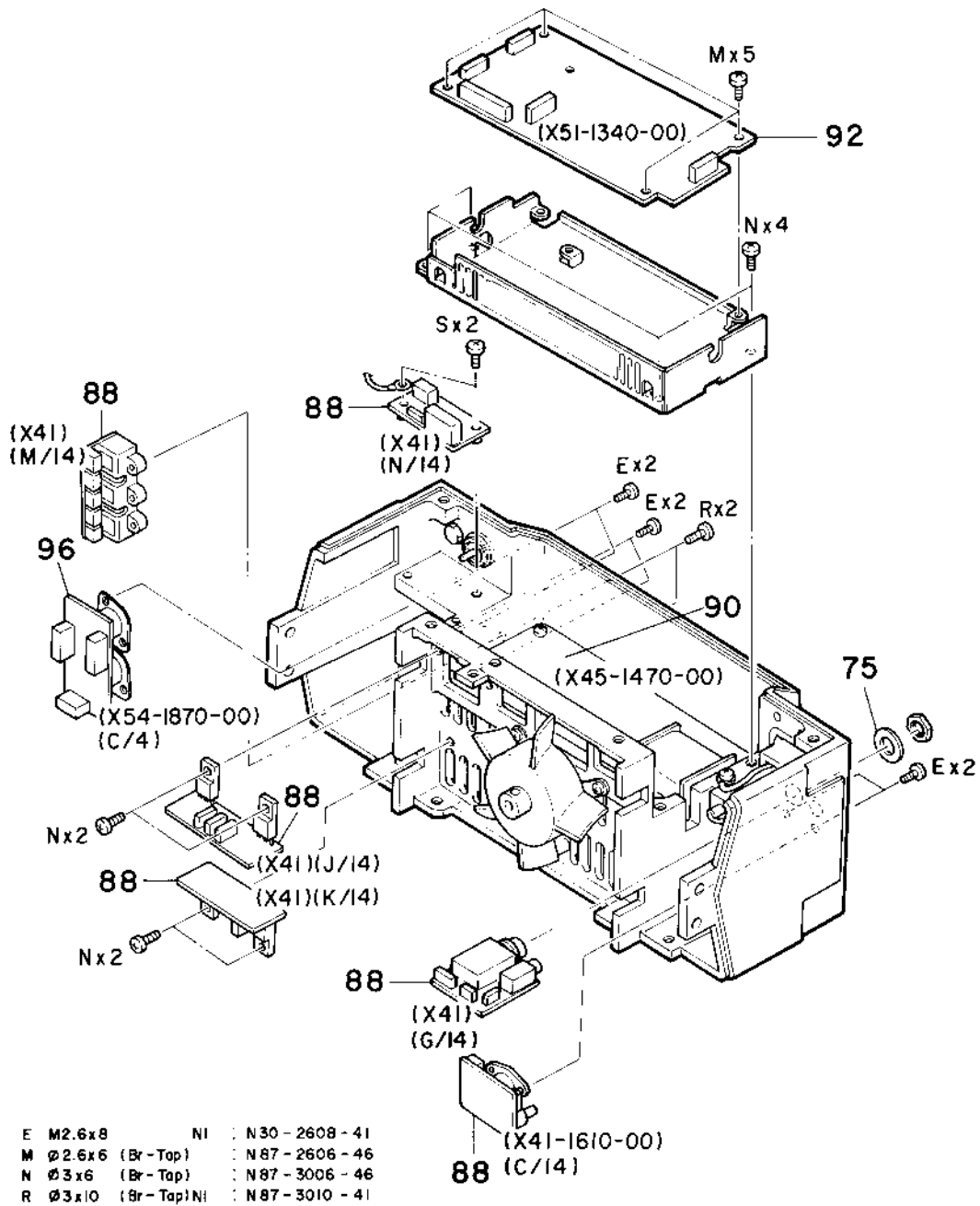

E	M2.6x8	NI	N30 - 2608 - 41
M	∅2.6x6 (Br-Tap)		N87 - 2606 - 46
N	∅3x6 (Br-Tap)		N87 - 3006 - 46
R	∅3x10 (Br-Tap)	NI	N87 - 3010 - 41

TS-440(E/8)

DISASSEMBLY

TS-440(F/8)

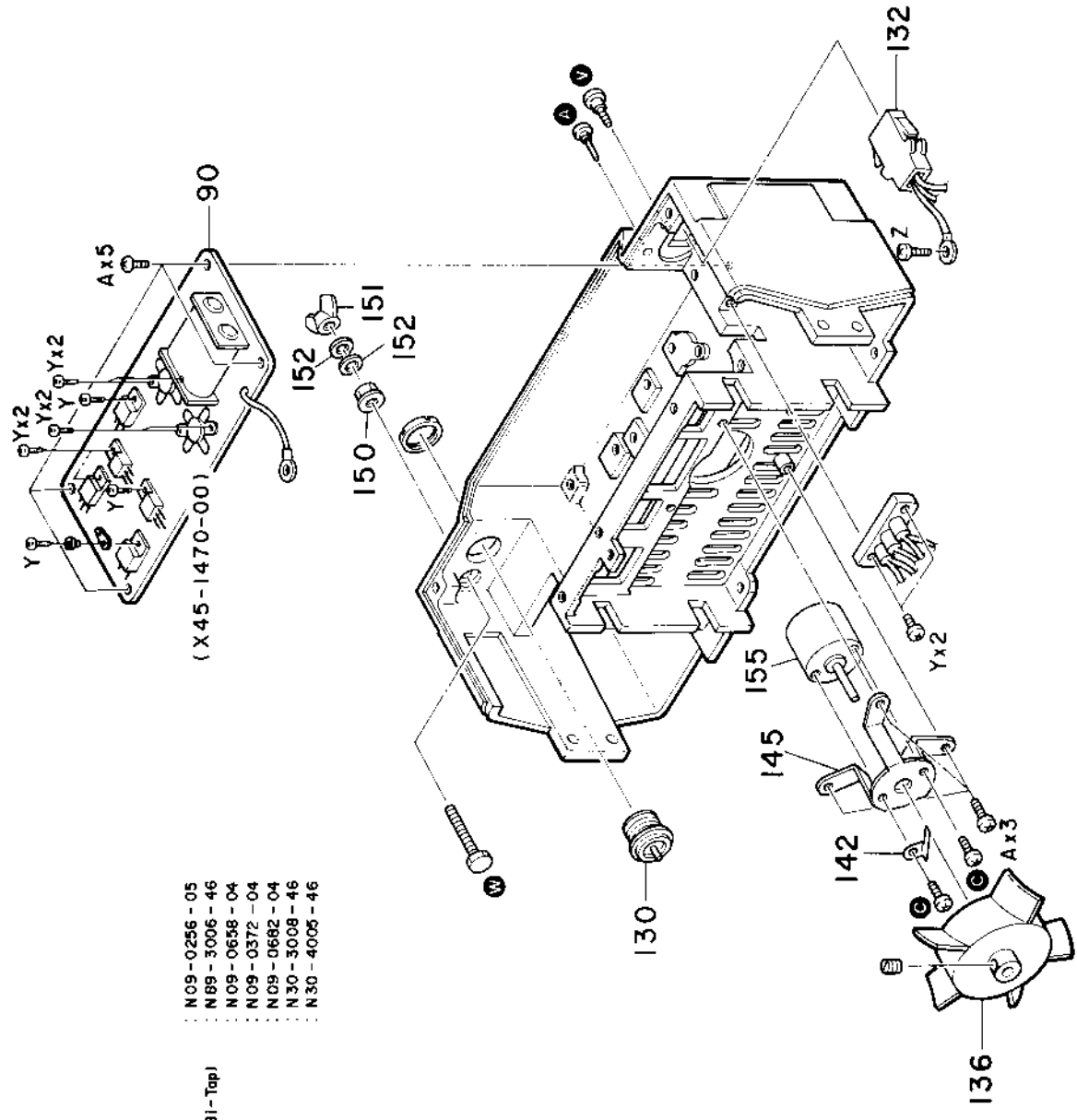

- GND
- A φ3x6 (81-Top)
- Y M3x8.8
- Z M4x5
- N09-0256-05
- N88-3006-46
- N09-0658-04
- N09-0372-04
- N09-0682-04
- N30-3008-46
- N30-4005-46

Parts with the exploded numbers larger than 700 are not supplied.

DISASSEMBLY

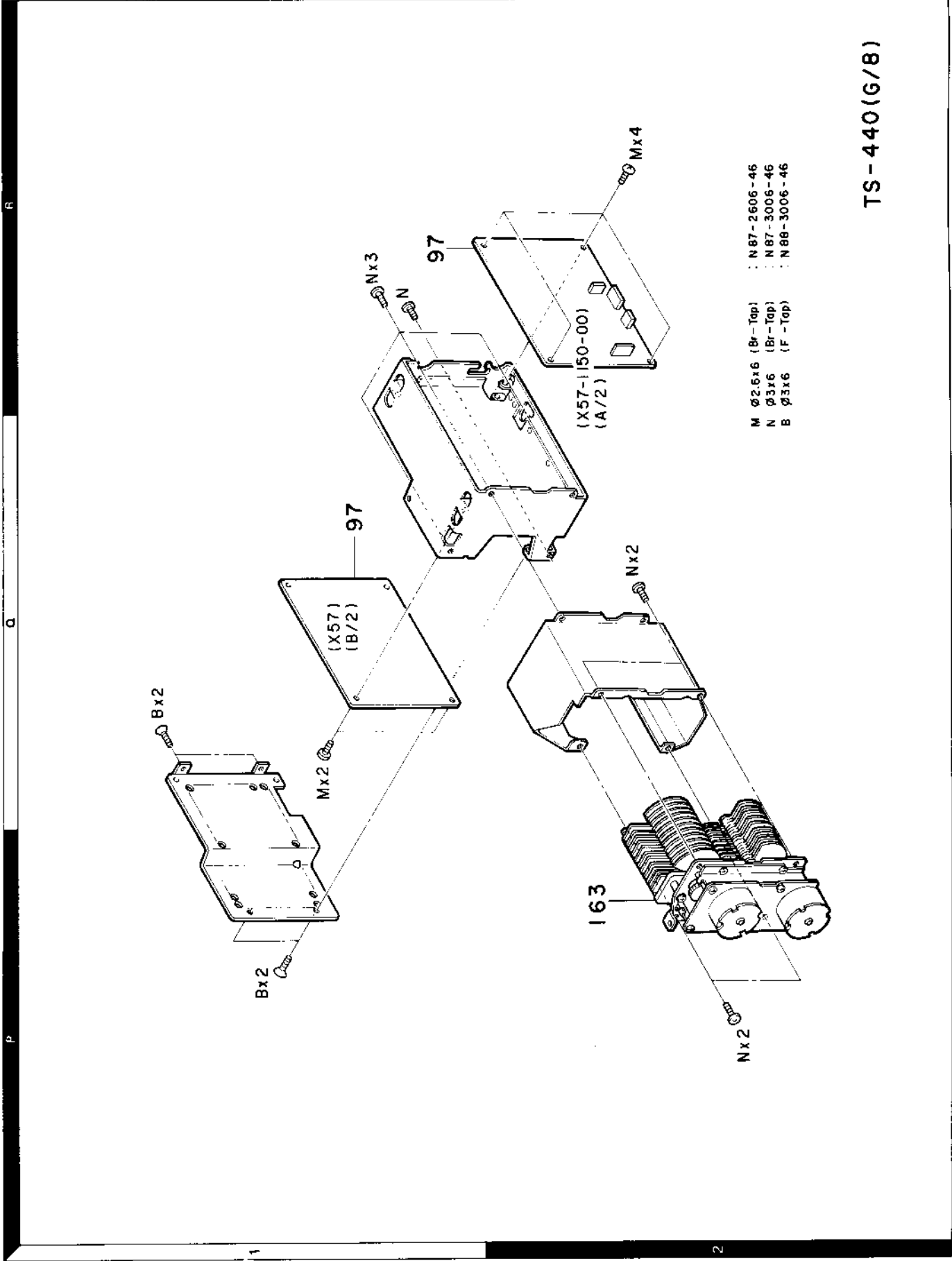

TS-440(G/8)

Parts with the exploded numbers larger than 700 are not supplied.

PACKING

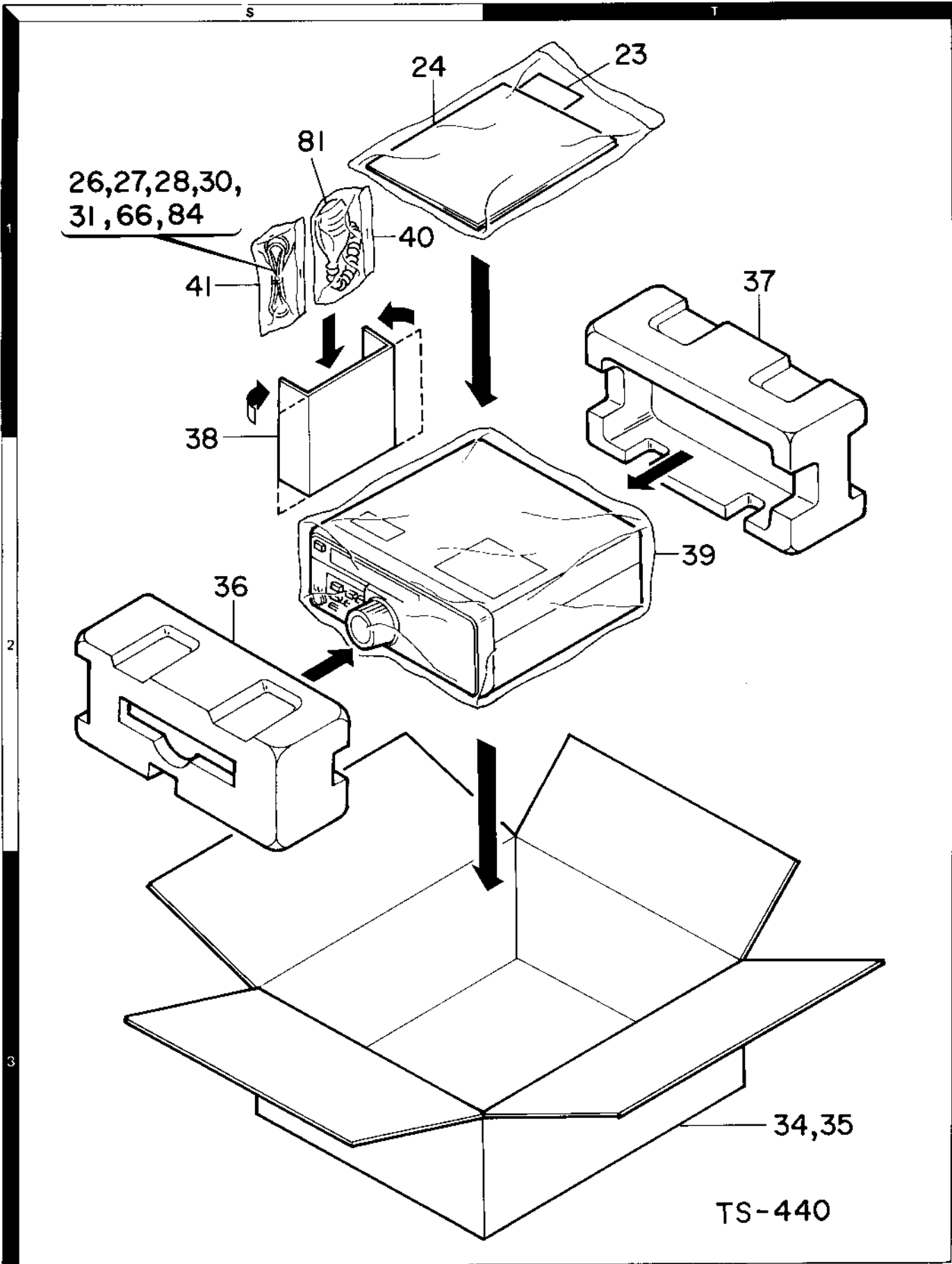

Parts with the exploded numbers larger than 700 are not supplied.

ADJUSTMENT

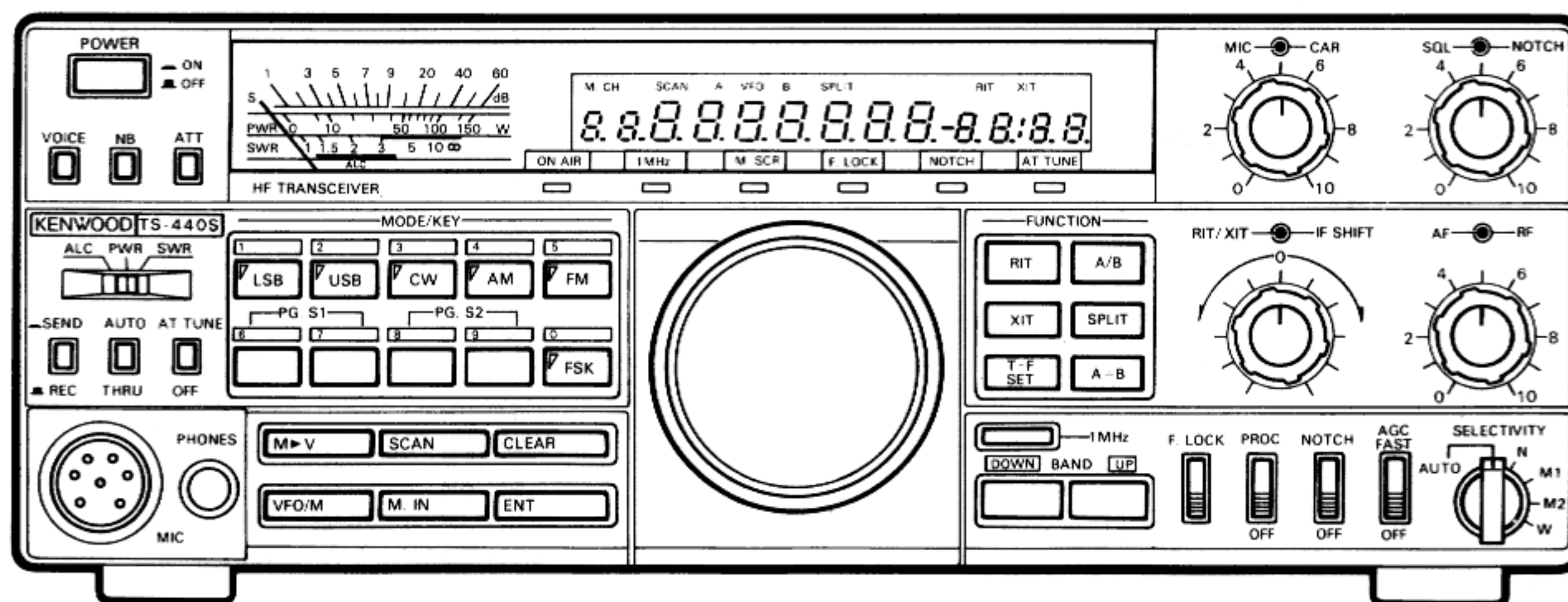

PREPARATION

Unless otherwise specified, set the controls as follows.

POWER.....ON	SELECTIVITYAUTO	CARMIN	ATT SWOFF
BAND14	AGC FAST.....SLOW	IF-SHIFTCENTER	SEND/RECREC
AFMIN	NOTCH SWOFF	FUNCTION	AUTOOFF
RFMAX	PROC SWOFF	A/B.....A	AT TUNE.....OFF
NOTCH.....CENTER	F.LOCK SWOFF	RIT,XIT,SPLITOFF	VOX SWOFF
SQUELCHMIN	1MHz SWOFF		
MIC.....MIN	NB SWOFF		

REQUIRED TEST EQUIPMENT

1. DC Voltmeter (DC V.M)

- 1) Input resistance: More than 1M Ω
 - 2) Voltage range: 1.5 to 1000V AC/DC
- NOTE:** A high-precision multimeter may be used. However, accurate reading can not be obtained for high-impedance circuits.

2. DC Ammeter

- 1) Current range: 1.5A, 3A, 20A, High-precision ammeter may be used.

3. RF VTVM (RF V.M)

- 1) Input impedance: 1M Ω and less than 3pF, min.
- 2) Voltage range: 10mV to 300V
- 3) Frequency range: 10kHz to 100MHz or greater

4. AF Voltmeter (AF V.M)

- 1) Frequency range: 50Hz to 10kHz
- 2) Input resistance: 1M Ω or greater
- 3) Voltage range: 10mV to 30V

5. AF Generator (AG)

- 1) Frequency range: 200Hz to 5kHz
- 2) Output: 1mV or less to 1V, low distortion

6. AF Dummy Load

- 1) Impedance: 8 Ω
- 2) Dissipation: 3W or greater

7. Oscilloscope (SCOPE)

Requires high sensitivity, and external synchronization capability.

8. Sweep Generator (SWEEP)

- 1) Center frequency: 50kHz to 90MHz
- 2) Frequency deviation: Maximum ± 35 MHz
- 3) Output voltage: 0.1V or greater

9. Standard Signal Generator (SSG)

- 1) Frequency range: 50kHz to 50MHz
 - 2) Output: -20dB/0.1 μ V to 120dB/1V
 - 3) Output impedance: 50 Ω
 - 4) AM and FM modulation can be possible.
- NOTE:** Generator must be frequency stable.

10. Frequency Counter (f. counter)

- 1) Minimum input voltage: 50mV
- 2) Frequency range: 50MHz or greater

11. Noise Generator

Must generate ignition noise containing harmonics beyond 30MHz.

12. RF Dummy Load

- 1) Impedance: 150 Ω and 20 Ω
- 2) Dissipation: 150W or greater

13. Power Meter

- 1) Impedance: 50 Ω
- 2) Dissipation: 150W continuous or greater
- 3) Frequency limits: 60MHz or greater

ADJUSTMENT

14. Spectrum Analyzer (SPE-ANA)

- 1) Frequency range: 100kHz to 110MHz or greater
- 2) Bandwidth: 1kHz to 3MHz

15. Detector

- 1) For adjustment of PLL/VCO BPF

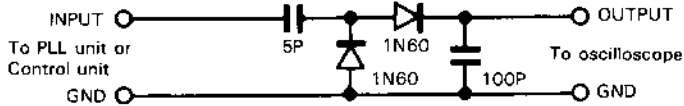

16. Directional Coupler

17. Power supply

PS-430

18. Microphone

MC-60A or MC-42S

< REFERENCE >

Japanese "SG"	American "SG"
-6 dB	0.25 μ V
0 dB	0.5 μ V
6 dB	1 μ V
12 dB	2 μ V
24 dB	8 μ V
30 dB	15.8 μ V
40 dB	50 μ V
50 dB	158 μ V
60 dB	500 μ V
70 dB	1.58mV
80 dB	5mV
90 dB	15.8mV
100 dB	50mV
120 dB	0.5V

ADJUSTMENT

• VOLTAGE CHECK, ADJUSTMENT

Item	Condition	Measurement			Adjustment			Specification/Remarks
		Test equipment	Unit	Terminal	Unit	Part	Method	
1. Voltage	1) POWER : ON RF GAIN : MAX MODE : USB STBY : REC	DC V.M	IF	19 - 5			Check	13.3 - 14.3V
				19 - 9				4.5 - 5.5V
				19 - 10				7.2 - 8.2V
				9 - 1	SW"A"	VR-4	2.6V	+0.05V, -0V
				27 - 4	IF	VR-5	8.8V	

• COMMON ADJUSTMENT

Item	Condition	Measurement			Adjustment			Specification/Remarks
		Test equipment	Unit	Terminal	Unit	Part	Method	
1. CAR	MODE : USB	Oscilloscope	IF	14 - 2	IF	L15	0.4V/p-p	±0.05V/p-p
		Freq. counter				TC2	8.3750MHz	±50Hz

• PLL ADJUSTMENT

Item	Condition	Measurement			Adjustment			Specification/Remarks	
		Test equipment	Unit	Terminal	Unit	Part	Method		
1. Reference oscillator frequency	36MHz	Freq. counter	PLL	TP6 (R96)	PLL	TC1	36.000,000MHz	±10Hz	
2. RIT	1) FREQ : 14.0000MHz MODE : AM RIT Pot : CENTER RIT SW : ON	DISPLAY			SW"A"	VR3	14.000,00 RIT.0.0		
	2) RIT Pot. : FULL CW (+) RIT Pot. : FULL CCW (-)								14.00120 RIT1.2 or more 13.998.80 RIT - 1.2 or more
3. VCO5		DC V.M	PLL	TR11 (R146)	PLL	T20	5.0V	±0.2V	
4. VCO4	1) FREQ : 14.0000MHz MODE : AM Disconnect PLL- 6 connector when PLL unlocked.	DC V.M	PLL	TP1 (L2)	PLL	T1	3.8V	±0.1V	
	2) MODE : USB								4.2 - 4.6V
	3) MODE : LSB								3.2 - 3.6V
	4) MODE : USB IF SHIFT Pot. : CENTER	Freq. counter	PLL	3 - 2	SW"A"	VR7	456.875kHz	±1	
	5) IF SHIFT Pot. : FULL CW							457.875kHz or more	
	6) IF SHIFT Pot. : FULL CCW							455.875kHz or less	
	7) IF SHIFT Pot. : CENTER							456.875kHz	456.874 - 456.876kHz
5. VCO3	1) FREQ : 13.9999MHz MODE : AM	DC V.M	PLL	TP2 (L13)	PLL	T2	6.2V	±0.1V	
	2) FREQ : 14.0000MHz MODE : AM								
6. PLL 6.6MHz BPF	1) FREQ : 14.0050MHz MODE : AM	Oscilloscope	PLL	TP3 (R60)	PLL	T3 - 5	MAX	Ref. 0.2V/p-p	

ADJUSTMENT

Item	Condition	Measurement			Adjustment			Specification/Remarks
		Test equipment	Unit	Terminal	Unit	Part	Method	
7. PLL 62MHz BPF	1) MODE : AM Readjust T9 (VCO2 OSC coil) to unlock. (Core is fully bottom position)	Tracking Gen.	PLL	IC8-1 (1 pin)				
	2) Connect 560Ω resistor in Tracking Gen. output line. Use oscilloscope's probe to connect to spectrum analyzer.	Spectrum analyzer Probe		TP4 (R64)		T6,7,8		
8. VCO2	1) Reset operation must also be performed. *See a microprocessor operation check. 1) FREQ : 14.0000MHz MODE : AM	DC V.M	PLL	TP5 (L21)	PLL	T9	6.4V	T9 has two peaking point. Adjust as shown below. ± 0.1V
	2) FREQ : 13.999,9 MHz MODE : AM							2.2 ~ 3.0V
	3) FREQ : 14.000,00 MHz MODE : AM	Spectrum analyzer	PLL	TP4 (R64)	PLL	VR1	L23 and L21 shorted to ground. (PLL unlocked) Adjust spurious radiation level. (58.25MHz)	
9. PLL 30MHz BPF	FREQ : 14.250.00MHz MODE : AM	Oscilloscope	PLL	TP7 IC12-5pin	PLL	T10,11,12	MAX	Ref. 0.3V/p-p
10. PLL 38.5-39MHz BPF	FREQ : 14.250.00MHz MODE : AM	Oscilloscope	PLL	TP8 (R112)	PLL	T13,14,15	MAX	Ref. 0.2V/p-p
11. PLL VCO (6.5-36MHz) BPF	1) Disconnect RF unit coax. cable (VCO)	Tracking Generator	PLL	IC14-1pin				
	2) Connect 580Ω resistor in Tracking Generator output line. Use oscilloscope's probe to connect to spectrum analyzer.	Probe Spectrum analyzer		TP9 (L33)	PLL	T16,17,18,19		
12. 39MHz Spurious radiation	FREQ : 24.9500MHz MODE : AM	Spectrum analyzer	PLL	TP9 (L33)	PLL	VR2		
13. VCO1	1) FREQ : 29.9999MHz MODE : AM	DC V.M	PLL	TP10 (R138)	RF	T21	2.5V	± 0.1V
	FREQ : 22.0000MHz					T22		5.3 ~ 6.3V
	2) FREQ : 21.9999MHz					T23		± 0.1V
	FREQ : 14.5000MHz					T24		5.3 ~ 6.3V
	3) FREQ : 14.9999MHz							± 0.1V
	FREQ : 7.5000MHz							5.3 ~ 6.3V
4) FREQ : 7.4999MHz		± 0.1V						
FREQ : 30.0 (30kHz)		5.5 ~ 6.5V						

ADJUSTMENT

• RX ADJUSTMENT

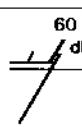
Item	Condition	Measurement			Adjustment			Specification/Remarks
		Test equipment	Unit	Terminal	Unit	Part	Method	
1. IF AMP (common)	FREQ : 14.1750MHz MODE : USB RF GAIN Control : MAX Use the minimum SSG input possible during alignment.	SSG AF V.M Oscilloscope AF dummy-load (8Ω)	Rear Panel	ANT EXT.SP	RF	T4,5,3 T7,8,15 9, 12, 10,11	MAX Repeat 2~3 times in case of T4,5,3,12, 10,11	S/N 10 dB or more at -6dB input. 1V or more/8Ω at AF GAIN control MAX.
2. 2nd MIX balance	FREQ : 14.1750MHz MODE : USB Connect the SSG to ANT terminal.	SSG AF V.M Oscilloscope			RF	VR2	MAX AF Noise level.	
3. 1st MIX balance	FREQ : 100.0 (100kHz) MODE : USB				RF	VR1	MIN AF noise level.	
4. IF TRAP	FREQ : 29MHz Band SSG : 45.05MHz OUT : 80 dB μ				RF	T1 TC1	Internal spurious beat MIN.	Repeat 2~3 times 70dB or more
5. RX DET Balance	1) FREQ : 14.1750 MHz MODE : USB RF GAIN : MIN IF SHIFT : CENTER RF GAIN : MAX after adjustment	RF V.M or Oscilloscope	IF	Q9 (emitter) (R77)	IF	TC1	MIN	
6. IF AMP (SSB)	FREQ : 14.1750MHz SSG : 14.1760 MHz OUT : 0 dB μ MODE : USB	SSG AF V.M Oscilloscope	Rear panel		IF	L1,2,3 4,18,5	MAX AF output Use the minimum SSG input possible during alignment.	
7. IF AMP (FM)	FREQ : 14.1750MHz SSG : 14.1750 MHz MOD : 1kHz, DEV: 3kHz OUTPUT : 30dB μ MODE : FM				IF	L6	MAX AF output	
8. S-METER (FM)	FREQ : 29.0000MHz MODE : FM SSG : MOD OFF OUTPUT : 30dB μ			ANT	IF	VR3	Full scale	60 dB 30dB \pm 10dB 
9. S-METER (SSB)	1) No signal (SSG output: OFF)	S-meter			IF	VR2	Set to starting point. (Meter zero)	
	2) FREQ : 14.1750 MHz MODE : USB SSG output : 8dB μ	SSG S-meter	Rear panel	ANT	IF	L3	S1 Adjust counter clockwise from peak. (turn slug out)	
	3) SSG output : 40dB μ					VR3	S9	40dB \pm 6dB
10. Squelch threshold	1) MODE : CW SELECTIVITY : WIDE SQL control : 12 o'clock	Speaker		EXT. SP	IF	VR4	Adjust VR slowly and stop at threshold.	12 o'clock
11. Noise Blanker	1) FREQ : 14.1750 MHz NB SW : ON SSG output : 14.175MHz First adjust 20dB input, then use the minimum input as possible.	SSG DC V.M Oscilloscope	Rear panel	ANT EXT SP	RF R146 (10kΩ)	T26 27	MIN	
	2) Noise Gen. : Low level	Noise Gen. SP				T26 27	MIN noise level	
12. Beeper	1) AF GAIN Control : 12 o'clock Depressing [A=B] and [AM] key at the same time 2) POWER SW : ON 3) Set to MEMORY CH17 when turning VFO.	AF V.M Oscilloscope AF dummy load		EXT. SP	IF	VR10	120mV/8Ω	\pm 10mV

ADJUSTMENT

• TX ADJUSTMENT

Item	Condition	Measurement			Adjustment			Specification/Remarks
		Test equipment	Unit	Terminal	Unit	Part	Method	
1. TX AMPM	1) FREQ: 14.1750 MHz MODE: CW CAR LEVEL control: MAX RF unit VR 4: CENER Disconnect DRV connector from RF unit. Then, connect as shown right. STBY: SEND 2) Reconnect this connector after adjustment.	Oscilloscope	RF	DRV	RF	VR5 T13, 16, 17	MAX	
2. Base Current	1) FREQ: 14.1750 MHz MODE: USB MIC LEVEL control: MIN CAR LEVEL control: MIN FINAL unit VR1, VR2: MIN Connect Ammeter ⊕: EXT Power supply ⊖: Power connector Adjust to minimum current with VR1 and VR2 in the Final unit. STBY: SEND	Ammeter			Final	VR1	Current drain (Minimum current) - 200 mA	First adjust VR1 and VR2 for minimum. Adjust VR1 for an increase of 200 mA when switched to TX. Then adjust VR2 for 200 mA over this reading.
						VR2	Current drain (Minimum current) + Driver current (200 mA) + 200 mA	
3. 1) ALC (RF Output power)	1) FREQ: 14.1750 MHz MODE: CW CAR LEVEL control: ALC scale MAX STBY: SEND	Power meter	Rear panel	ANT	Filter	VR1	95 W	Caution: In no case should the power be adjusted for greater than 110 watts.
2) Power meter	2) METER SW: PWR STBY: SEND					VR6	Set to PWR meter 95 W reading	
4. Power down	1) FREQ: 29.7000MHz MODE: CW CAR LEVEL control: ALC scale MAX Connect ACC socket pin (PD) to 50 W from NC. STBY: SEND 2) Reconnect this connector (PD) to NC after adjustment.	Power meter			Filter	VR3	50 W	± 2.5 W
5. Protection	1) FREQ: 14.2000MHz MODE: CW Coax. cable to 150Ω dummy load should be 1 m long. STBY: SEND	150Ω RF dummy load Power meter	Rear panel	ANT	Filter	VR2	30W	
								18A or less
6. ALC meter	1) FREQ: 14.2000 MHz MODE: USB MIC LEVEL control: MIN CAR LEVEL control: MIN METER SW: ALC STBY: SEND	Power meter	Rear panel	ANT	Filter	VR4	Set to S meter "0"	*If this adjustment is performed, step 2) Base current must also be performed.
		Power meter AG AF VM			Filter	VR4	Set to ALC meter starting point.	
						VR5	Adjust for maximum ALC scale reading	
7. Spurious	FREQ: 21.2000 MHz MODE SW: CW CAR LEVEL control: ALC scale MAX STBY: SEND	Power meter Spectrum analyzer			RF	VR4	MIN	- 40 dB or less.

ADJUSTMENT

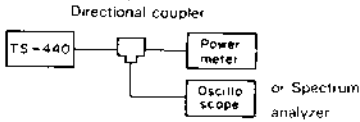
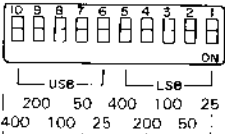
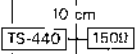
Item	Condition	Measurement			Adjustment			Specification/Remarks
		Test equipment	Unit	Terminal	Unit	Part	Method	
8. Carrier suppression	FREQ: 14.1750 MHz MODES: USB and LSB MIC LEVEL control: MIN STBY: SEND	Power meter Oscilloscope or Spectrum analyzer	Rear Panel	ANT (Directional coupler)	IF	VR 7,8	MIN 	-40 dB or less
9. SSB made frequency response	FREQ: 14.1750 MHz MODES: USB and LSB AG output: Two tones 5 mV 300, 2700 Hz Set output to 50 W using MIC LEVEL control. STBY: SEND	Oscilloscope	Rear panel	ANT (Directional coupler) DIP SW	Cont.	S50 (DIP SW)	Adjust as shown below.  DIP SW are adjustable from 400 to -375 Hz.	*If this adjustment is performed, step 8 must also be performed.
If two tone generator is not available, adjust for equal output power at 300, 2700 Hz, as measured on wattmeter.								
10. Speech processor	1) FREQ: 14.2000 MHz MODE: USB AG output: 1 kHz, 10 mV Set output to 50 W using MIC LEVEL control PROC SW: ON and OFF STBY: SEND	Power meter AG AF V. M.	Rear panel	ANT	IF	VR6	Level should be the same between ON and OFF	
	2) AG output: 1kHz, 1 mV (20 dB down) STBY: SEND							25W or more
11. FM. DEV	1) FREQ: 28.7000 MHz MODE: FM AG output: 1 kHz, 30 mV 50 mV (K)	Power meter Linear detector AG AF V. M.	Rear panel	ANT (Directional coupler)	RF	VR6	4.6 kHz	±0.1 kHz
	2) AG output: 1 kHz, 3 mV 5 mV (K)				RF	VR3	3 kHz	+0.1 kHz
12. CW Side tone	MODE: CW CW BREAK IN SW: SEMI AF GAIN control: 12 o'clock VOX GAIN control: MIN STBY: REC Connect KEY to KEY jack and close the key contacts.	Power meter AF V.M Oscilloscope		EXT. SP	IF	VR9	0.63V/8Ω	
13. Auto antenna tuner (If AT-440 is installed)	1) BAND: 28.5000 MHz MODE: CW CAR LEVEL control: MAX AT unit VR1: 12 o'clock VR2: Fully CCW AUTO-THRU SW: AUTO ATTUNE SW : ON	150Ω RF dummy load			AT	TC1	Minimum SWR meter reading 	Repeat 2 - 3 times.

ADJUSTMENT

Item	Condition	Measurement			Adjustment			Specification/Remarks
		Test equipment	Unit	Terminal	Unit	Part	Method	
	2) AT TUNE SW: OFF Disconnect No. 1 connector from AT unit. STBY: SEND Set. SWR 1.25 reading when VFO dial is turned.	Set as shown right.						
	3) STBY: REC AT TUNE: ON					AT	VR2	Adjust VR2 until AT TUNE indicator just goes off.
	4) AF TUNE: OFF Reconnect No. 1 connector after adjustment.							

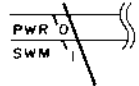

ADJUSTMENT

MICROPROCESSOR OPERATION CHECK

Item	Condition	Operation check																		
1. Reset check	1) FUNCTION SW: A POWER SW: OFF Set the POWER SW ON while depressing the A=B key. Then release the A=B key.	FREQ: 14,000.0kHz MODE: USB VFO A: Lights The "Beeper" sound simultaneously with POWER ON.																		
	2) FUNCTION SW: B	FREQ: 14,000.0kHz MODE: USB VFO B: Lights																		
	3) VFO/M SW: ON M.CH SW: Change the channels in 00 through 99 order.	The frequency display disappears. M.CH display lights and displays 00-99 order. Split display lights when turning VFO dial 90-99.																		
2. Band	1) VFO/M SW: OFF 1MHz STEP SW: OFF Depress the "BAND : UP" key once. Press repeatedly.	FREQ : 1 8 , 0 00.0kHz The "Beeper" sounds simultaneously. The MHz display □ □ , □ counts up. The "Beeper" sounds simultaneously.																		
	2) Hold the "BAND : UP" on.	FREQ: <table style="margin-left: auto; margin-right: auto; border-collapse: collapse;"> <tr> <td style="text-align: center;">14,000.0</td> <td style="text-align: center;">18,000.0</td> </tr> <tr> <td style="text-align: center;">↑</td> <td style="text-align: center;">↓</td> </tr> <tr> <td style="text-align: center;">10,000.0</td> <td style="text-align: center;">21,000.0</td> </tr> <tr> <td style="text-align: center;">↑</td> <td style="text-align: center;">↓</td> </tr> <tr> <td style="text-align: center;">7,000.0</td> <td style="text-align: center;">24,500.0</td> </tr> <tr> <td style="text-align: center;">↑</td> <td style="text-align: center;">↓</td> </tr> <tr> <td style="text-align: center;">3,500.0</td> <td style="text-align: center;">28,500.0</td> </tr> <tr> <td style="text-align: center;">↑</td> <td style="text-align: center;">↓</td> </tr> <tr> <td style="text-align: center;">1,500.0</td> <td style="text-align: center;">29,500.0</td> </tr> </table> The "Beeper" sounds at each Key-press.	14,000.0	18,000.0	↑	↓	10,000.0	21,000.0	↑	↓	7,000.0	24,500.0	↑	↓	3,500.0	28,500.0	↑	↓	1,500.0	29,500.0
	14,000.0	18,000.0																		
	↑	↓																		
	10,000.0	21,000.0																		
↑	↓																			
7,000.0	24,500.0																			
↑	↓																			
3,500.0	28,500.0																			
↑	↓																			
1,500.0	29,500.0																			
3) Depress the "BAND: DOWN" key once. Repeat the operation.	FREQ: □ □ , □ 00.0kHz Displays 1MHz lower frequency than that previously displayed in 2). The "Beeper" sounds. The frequency display steps down 1MHz at each key-press. The "Beeper" sounds.																			
4) Hold the "BAND: DOWN" key on.	The frequency display in 2) steps down. The "Beeper" sounds at each key-press.																			
5) 1MHz STEP SW: ON Hold the "UP" key on.	1MHz LED (green) lights. FREQ: □ □ ,000.0kHz The MHz display □ □ advances 1MHz at each key-press.																			
	Hold the "DOWN" key on.	The display steps down 1MHz at each key-press.																		

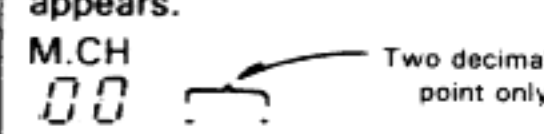
Item	Condition	Operation check																									
3. Dial	1) FREQ: 0,000.0kHz ① Check to see if the display does not change by turning the VFO control counterclockwise. And adjust the index by turning it in the same way. ② Turn the VFO control slowly clockwise.																										
4. MODE function (LSB, USB, CW, AF, FM, FSK)	Change MODE (ex: depress CW once)	CW "C" morse code ----- EX: LSB ----- USB ----- CW ----- AM ----- FM ----- FSK ----- LED lights when depressing MODE SW.																									
5. ENT KEY	1) Depress the ENT once.	The frequency display disappears. ----- Seven bar's segment and two decimal point displayed.																									
	<div style="border: 1px solid black; padding: 5px; margin: 5px;"> <p style="text-align: center;">MODE/KEY</p> <table style="width: 100%; border-collapse: collapse;"> <tr> <td style="text-align: center;">1</td><td style="text-align: center;">2</td><td style="text-align: center;">3</td><td style="text-align: center;">4</td><td style="text-align: center;">5</td> </tr> <tr> <td style="text-align: center;">LSB</td><td style="text-align: center;">USB</td><td style="text-align: center;">CW</td><td style="text-align: center;">AM</td><td style="text-align: center;">FM</td> </tr> <tr> <td colspan="2" style="text-align: center;">PG.S1</td><td colspan="3" style="text-align: center;">PG.S2</td> </tr> <tr> <td style="text-align: center;">6</td><td style="text-align: center;">7</td><td style="text-align: center;">8</td><td style="text-align: center;">9</td><td style="text-align: center;">10</td> </tr> <tr> <td style="text-align: center;"> </td><td style="text-align: center;"> </td><td style="text-align: center;"> </td><td style="text-align: center;"> </td><td style="text-align: center;">FSK</td> </tr> </table> </div>	1	2	3	4	5	LSB	USB	CW	AM	FM	PG.S1		PG.S2			6	7	8	9	10					FSK	2) Depress MODE/KEY 1 6 7 8 9 ENT
1	2	3	4	5																							
LSB	USB	CW	AM	FM																							
PG.S1		PG.S2																									
6	7	8	9	10																							
				FSK																							
6. Memory write 100 CH memory 00-89: NORMAL 91-99: SPLIT CH	1) FREQ: 14.0000MHz MODE: USB VFO/M SW: ON	The frequency displays disappears. M.CH  Two decimal point only M.CH display lights and displays 00 in order.																									
	2) Repeat VFO/M SW: ON	FREQ: 14.0000MHz The "Beeper" sounds simultaneously.																									
	3) M.IN SW: ON	The frequency display disappears. M.CH display lights and displays 00 in order. M.SCR LED light.																									
	4) M.IN SW: ON again	FREQ: 14.0000MHz (Memory is written already)																									
	5) VFO/M SW: ON	FREQ 14.0000 MHz M.CH display lights and displays 00 in order.																									

ADJUSTMENT

TOP VIEW

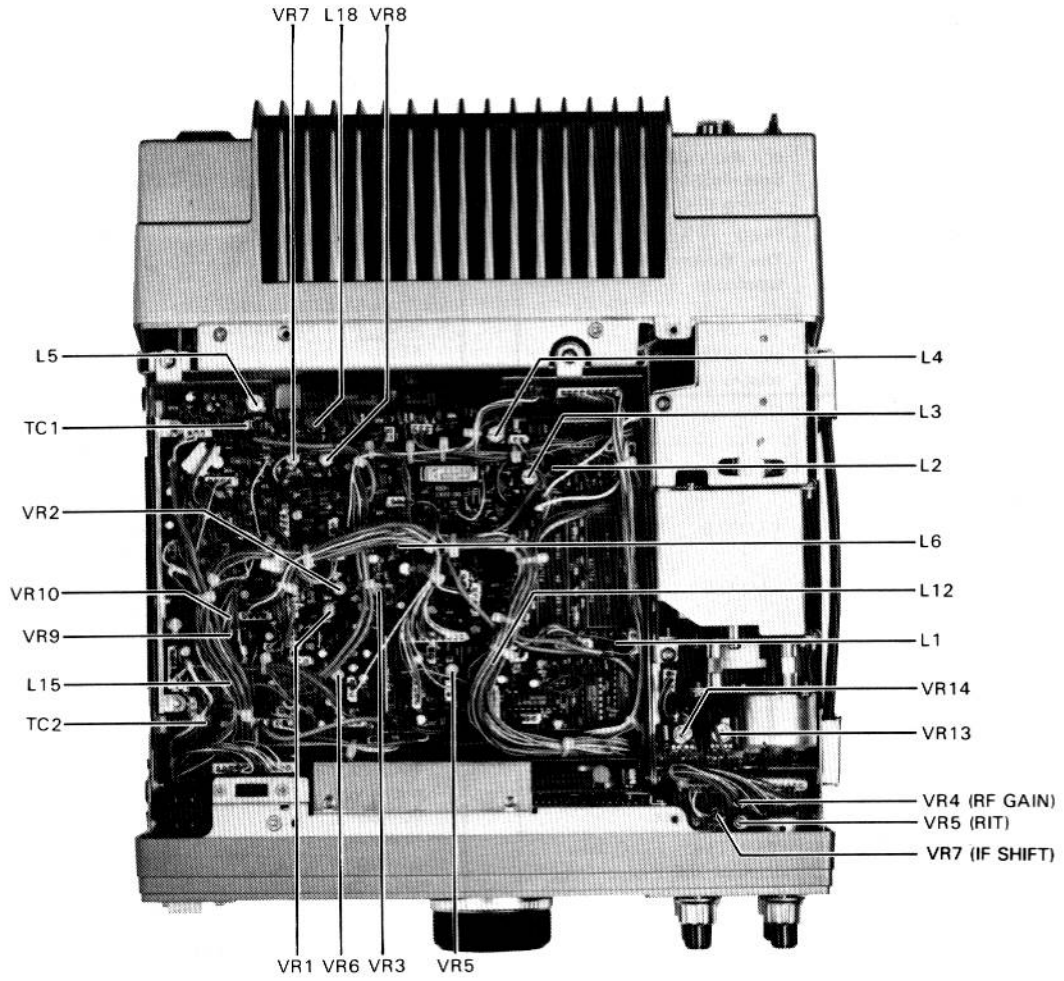

ADJUSTMENT

INNER VIEW

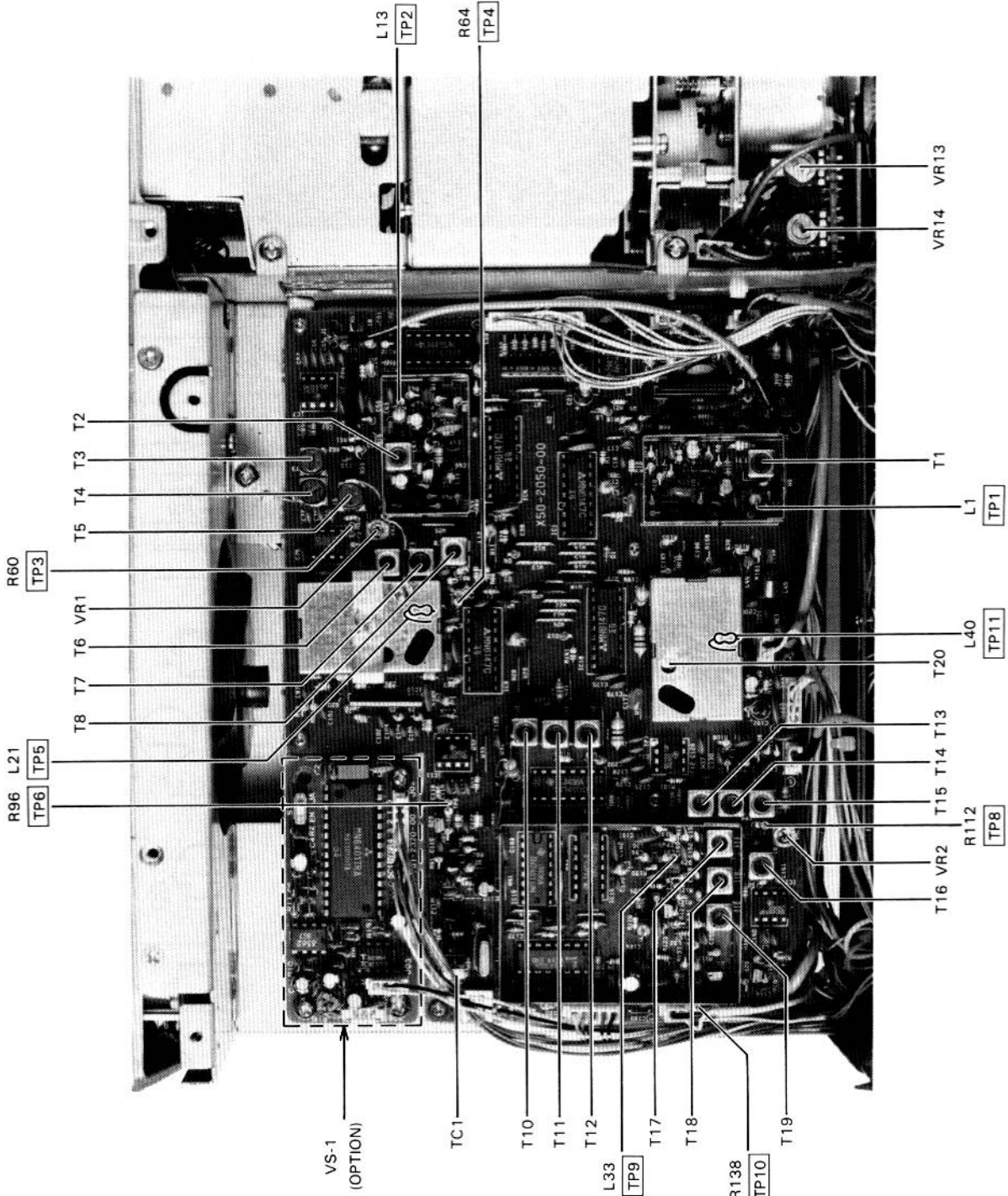

ADJUSTMENT

BOTTOM VIEW

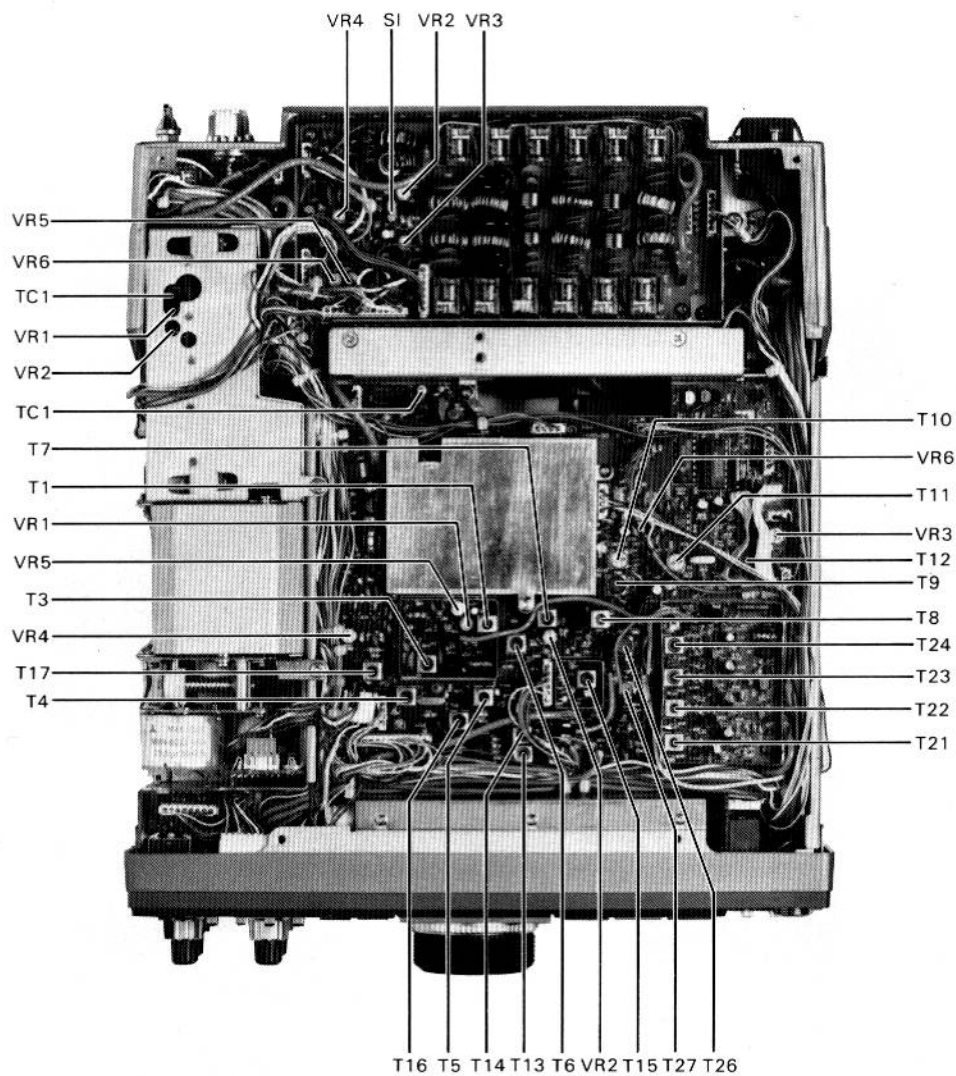

LEVEL DIAGRAM

RX SECTION

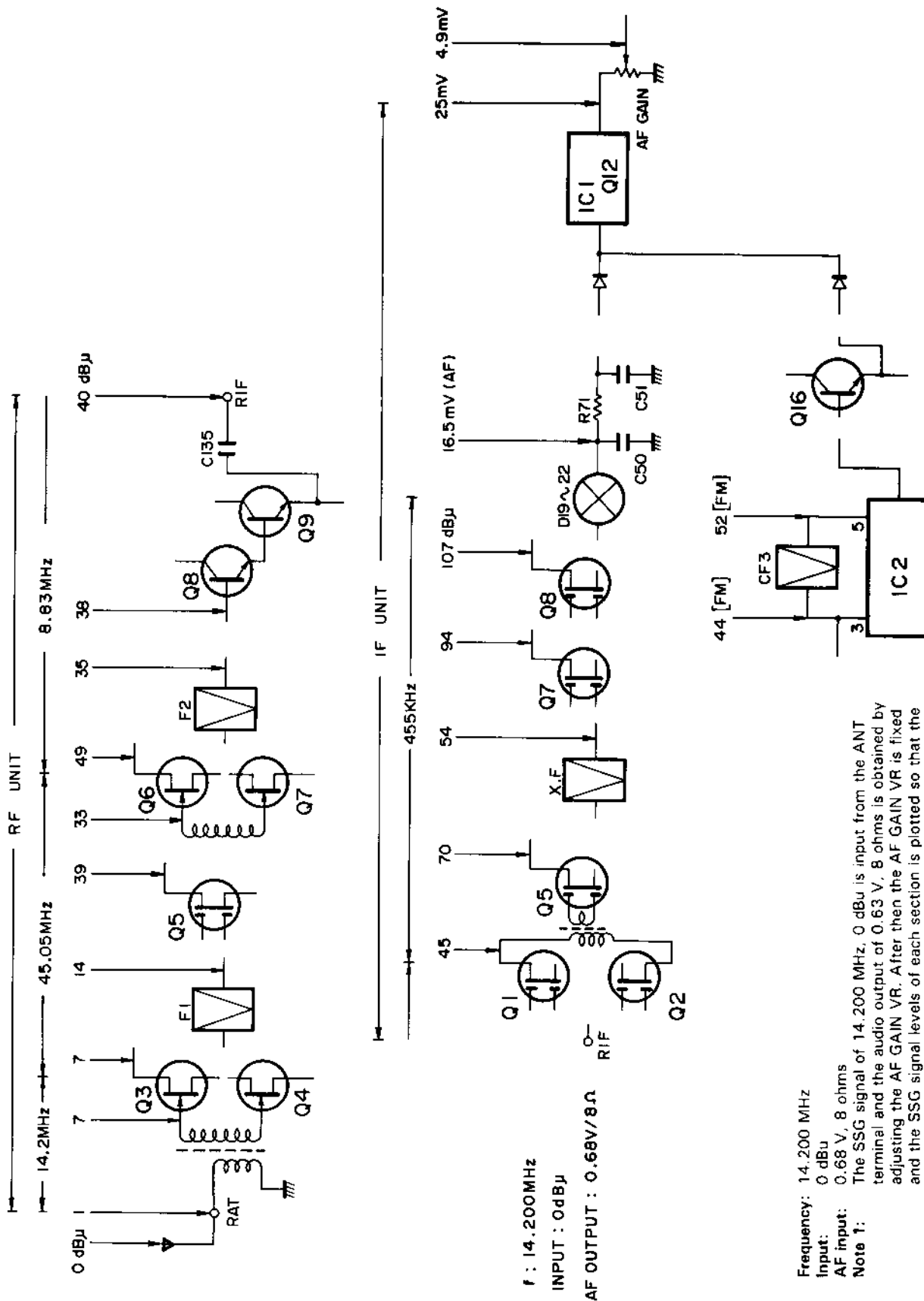

f : 14.200MHz
 INPUT : 0dBj
 AF OUTPUT : 0.68V/8Ω

Frequency: 14.200 MHz
 Input: 0 dBu
 AF input: 0.68 V, 8 ohms

Note 1: The SSG signal of 14.200 MHz, 0 dBu is input from the ANT terminal and the audio output of 0.63 V, 8 ohms is obtained by adjusting the AF GAIN VR. After then the AF GAIN VR is fixed and the SSG signal levels of each section is plotted so that the fixed level audio output.

Note 2: In the FM mode, this is the signal level to obtain the same value as the S/N ratio at 0 dBu signal input.

Note 3: The SSG output is measured through 0.01 uF ceramic capacitor (barium titanate capacitor).

LEVEL DIAGRAM

TX SECTION

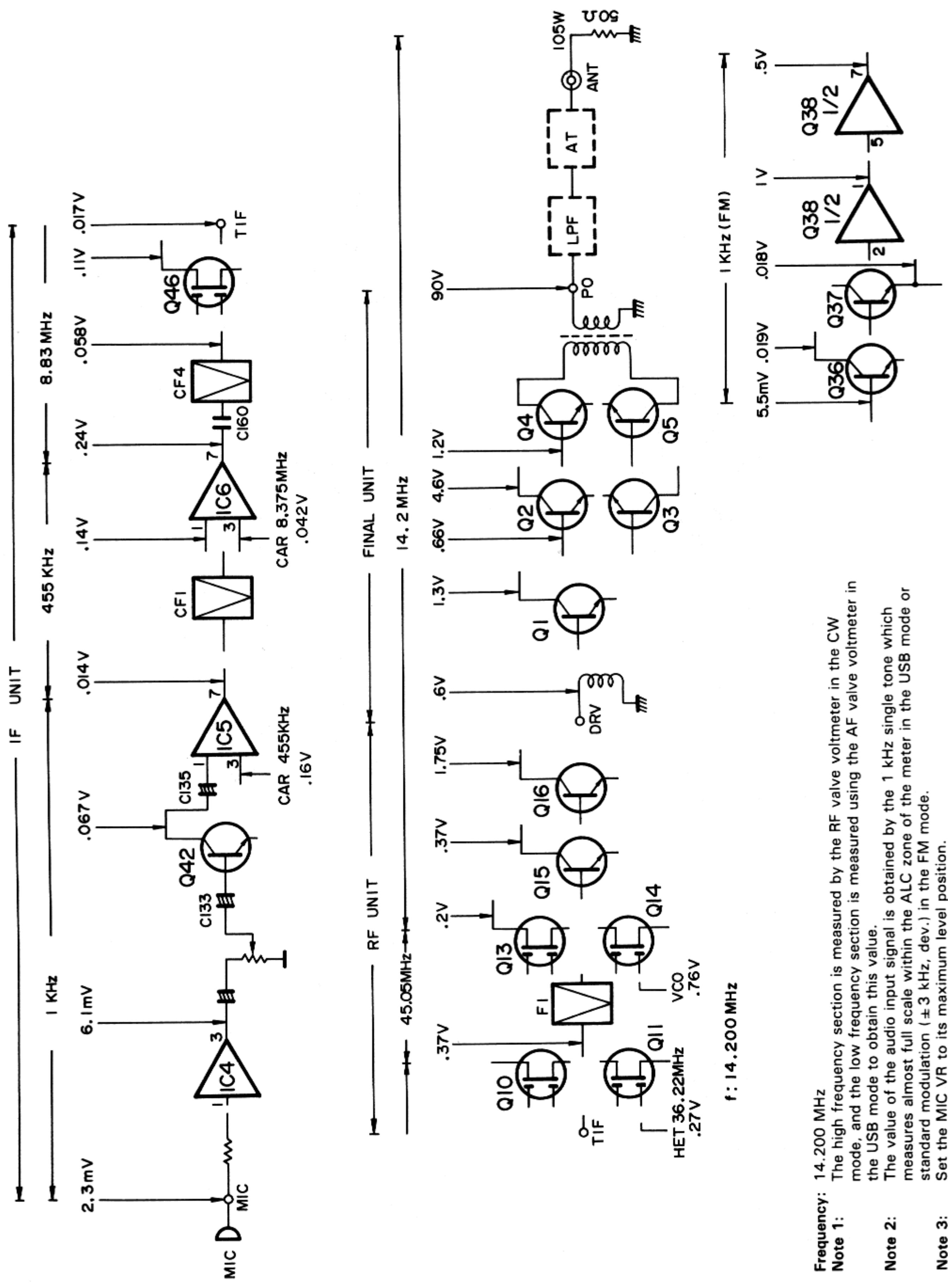

Frequency: 14.200 MHz
Note 1: The high frequency section is measured by the RF valve voltmeter in the CW mode, and the low frequency section is measured using the AF valve voltmeter in the USB mode to obtain this value.
Note 2: The value of the audio input signal is obtained by the 1 kHz single tone which measures almost full scale within the ALC zone of the meter in the USB mode or standard modulation (± 3 kHz, dev.) in the FM mode.
Note 3: Set the MIC VR to its maximum level position.

BLOCK DIAGRAM

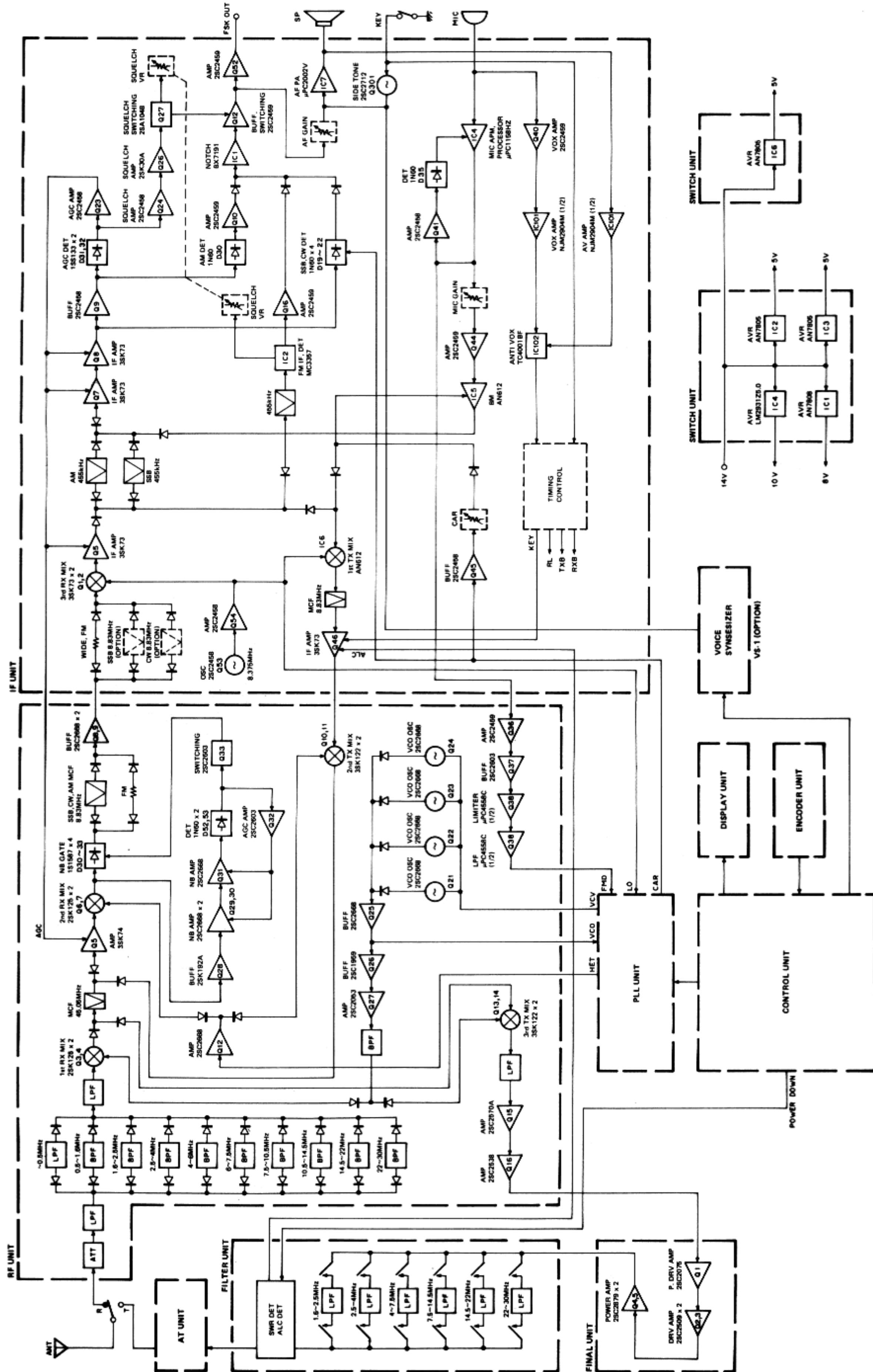

ADJUSTMENT

1. OUTPUT VOLTAGE

- 1) Connect the load and set the current to 20A.
- 2) Adjust output voltage to $13.8\text{ V} \pm 0.4\text{ V}$ with VR1.

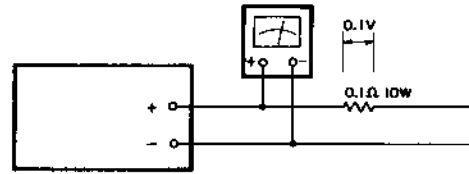

2. PROTECTION CIRCUIT

- 1) POWER SW: OFF
- 2) Connect a 0.1 Ω 10 W resistor.
- 3) POWER SW: ON
- 4) Adjust VR2 so that 0.1V DC is obtained.

PACKING

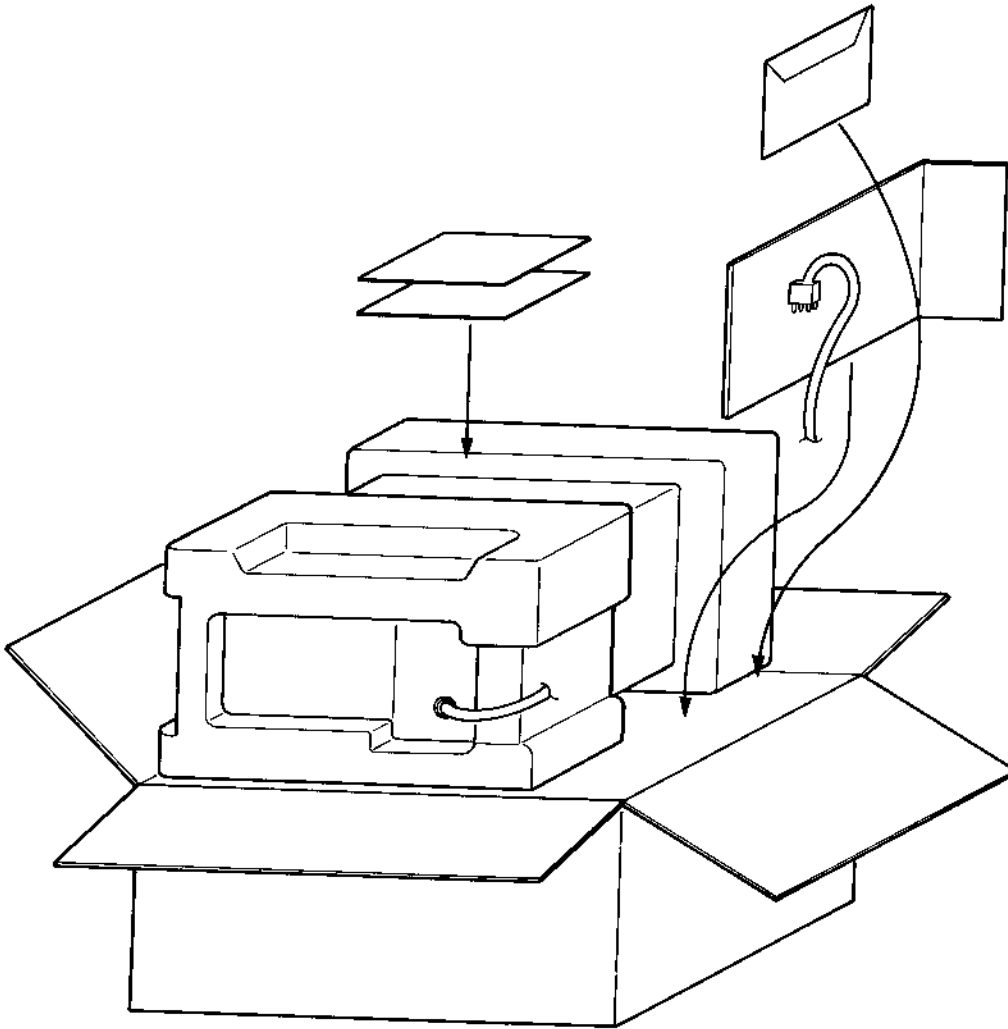

SCHEMATIC DIAGRAM/PC BOARD

SCHEMATIC DIAGRAM (X43-1520-00)

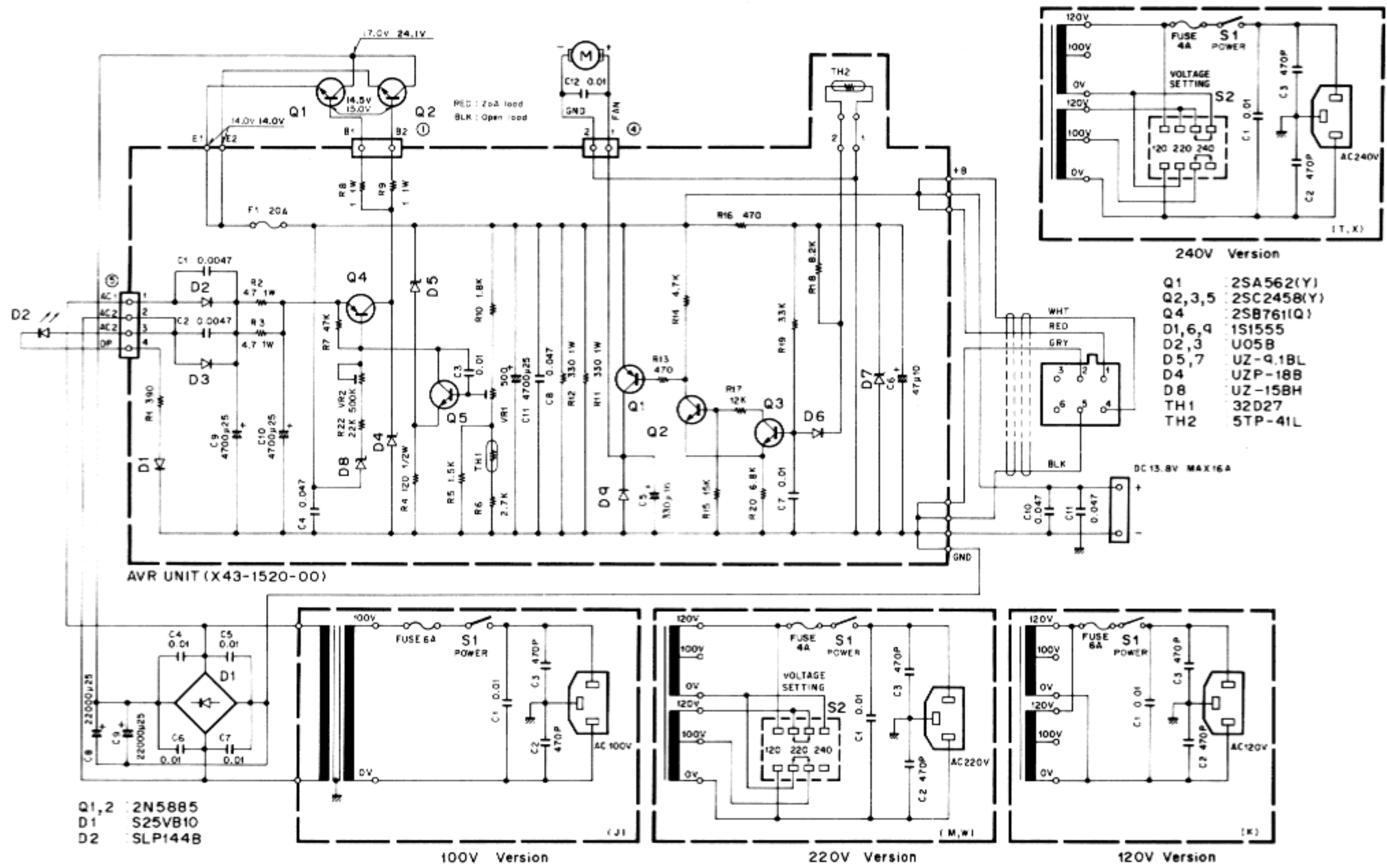

PC BOARD VIEW (X43-1520-00) AVR UNIT Component side view

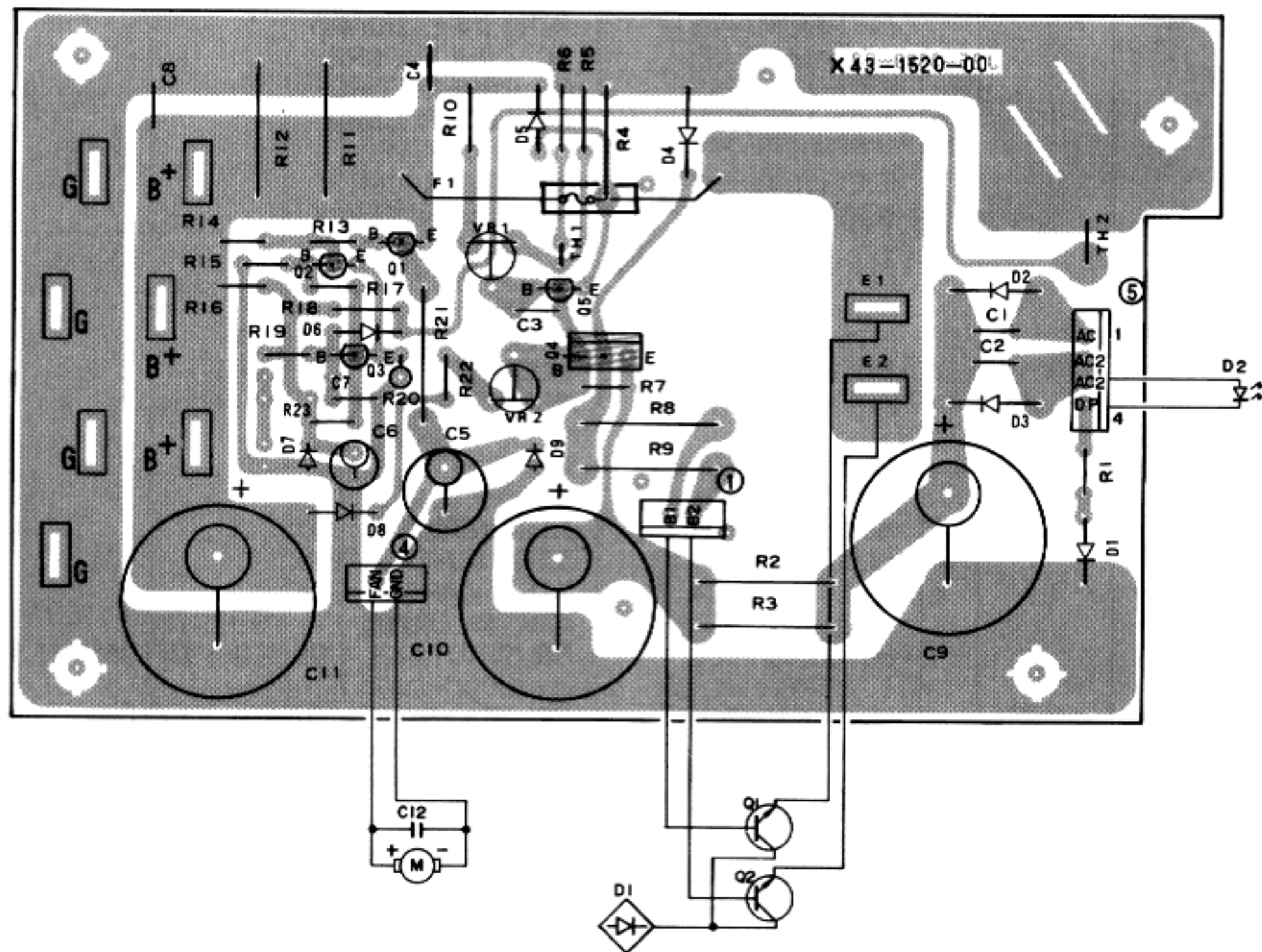

PARTS LIST

* New Parts

Parts without Parts No. are not supplied.

Les articles non mentionnés dans le Parts No. ne sont pas fournis.

Teile ohne Parts No. werden nicht geliefert.

PARTS LIST

Ref. No. 参照番号	Address 位置	New Parts 新	Parts No. 部品番号	Description 部品名 / 規格	Desti- nation 仕向	Re- marks 備考
PS-50						
-		*	A01-1000-02	CASE (UPPER)		
-		*	A01-1001-12	CASE (LOWER)		
-		*	A01-1002-12	CASE (LOWER)		
-		*	A20-2561-03	PANEL ASSY	KMW	
-		*	A20-2561-03	PANEL ASSY	X	
-		*	A20-2562-03	PANEL ASSY	T	
-		*	A23-1491-03	REAR PANEL		
-		*	B40-3640-04	MODEL NAME PLATE	K	
-		*	B40-3641-04	MODEL NAME PLATE	MWX	
-		*	B40-3642-04	MODEL NAME PLATE	T	
-		*	B41-0627-14	CAUTION LABEL (220V)	MW	
-		*	B41-0630-04	CAUTION LABEL (240V)	TX	
-		*	B42-1733-14	CAUTION LABEL (120V/220V/240V)	MTW	
-		*	B42-1733-14	CAUTION LABEL (120V/220V/240V)	X	
-		*	B42-1770-04	LABEL (FUSE, 4A)	MTW	
-		*	B42-1770-04	LABEL (FUSE, 4A)	X	
-		*	B42-2430-04	CAUTION LABEL (120V)	K	
-		*	B46-0411-00	WARRANTY CARD	K	
-		*	B50-8051-00	INSTRUCTION MANUAL	KMW	
-		*	B50-8051-00	INSTRUCTION MANUAL	X	
-		*	B50-8052-00	INSTRUCTION MANUAL	T	
C1		*	C91-0647-05	CERAMIC 0.01UF P		
C2 ,3		*	C91-0496-05	CERAMIC 470PF K		
C4 -7		*	CK45E2H103P	CERAMIC 0.010UF P		
C8 ,9		*	C90-2034-05	ELECTRO 22000UF 25WV		
C10 ,11		*	CK45F1H473Z	CERAMIC 0.047UF Z		
C12		*	CK45F1H103Z	CERAMIC 0.010UF Z		
-		*	E18-0351-05	SOCKET		
-		*	E20-0283-05	TERMINAL BOARD		
-		*	E30-1639-05	AC POWER CORD		
-		*	E30-1643-15	AC POWER CORD	KM	
-		*	E30-1644-15	AC POWER CORD	T	
-		*	E30-1645-05	AC POWER CORD	W	
-		*	E30-1647-05	AC POWER CORD	X	
-		*	F01-0939-03	HEAT SINK		
-		*	F05-4022-05	FUSE (4A)	MTW	
-		*	F05-4022-05	FUSE (4A)	X	
-		*	F05-6021-05	FUSE (6A)		
-		*	F09-0410-04	HEAD PROTECTOR (FAN)		
-		*	G02-0549-04	LEAF SPRING		
-		*	H01-4693-04	ITEM CARTON BOX	KMW	
-		*	H01-4693-04	ITEM CARTON BOX	X	
-		*	H01-4694-04	ITEM CARTON BOX	T	
-		*	H03-2281-04	CARTON BOX (OUTSIDE)		
-		*	H10-2567-02	POLYSTYRENE FOAMED FIXTURE (F)		
-		*	H10-2568-02	POLYSTYRENE FOAMED FIXTURE (R)		
-		*	H12-1389-04	PACKING FIXTURE		
-		*	H20-1430-03	PROTECTION COVER		
-		*	H25-0105-04	PROTECTION BAG		
-		*	J02-0323-05	F00T (F)		

PARTS LIST

× New Parts

Parts without Parts No. are not supplied.

Les articles non mentionnés dans le Parts No. ne sont pas fournis.

Teile ohne Parts No. werden nicht geliefert.

Ref. No. 参照番号	Address 位置	New Parts 新	Parts No. 部品番号	Description 部品名 / 規格	Desti- nation 仕向	Re- marks 備考
-			J02-0442-04	FOOT (R)		
-			J02-0443-04	FOOT (/3.2)		
-			J13-0033-15	FUSE HOLDER		
-			J21-4153-14	MOUNTING HARDWARE(MOTOR)		
-		*	J21-4179-04	MOUNTING HARDWARE(ELECTRS)		
-			J21-4180-03	MOUNTING HARDWARE(FAN)		
-		*	J21-4181-14	MOUNTING HARDWARE(P. T)		
-		*	J30-0542-04	SPACER		
-			J42-0403-05	POWER CORD BUSHING		
-			J61-0408-05	WIRE BAND		
-			K29-0758-04	PUSH KNOB		
-			L01-8286-05	POWER TRANSFORMER		
-			N09-0256-05	SCREW		
-			N09-0658-04	SCREW		
-			N10-2030-46	HEXAGON NUT		
-			N15-1030-46	FLAT WASHER		
-			N30-2604-46	PAN HEAD MACHINE SCREW		
-			N30-3014-46	PAN HEAD MACHINE SCREW		
-			N30-4016-46	PAN HEAD MACHINE SCREW		
-			N33-3006-41	OVAL HEAD MACHINE SCREW		
-			N35-3006-41	BINDING HEAD MACHINE SCREW		
-			N35-3008-41	BINDING HEAD MACHINE SCREW		
-			N87-3006-41	BRAZIER HEAD TAPTITE SCREW		
-			N87-3006-46	BRAZIER HEAD TAPTITE SCREW		
-			N87-3012-45	BRAZIER HEAD TAPTITE SCREW		
-			N87-3014-46	BRAZIER HEAD TAPTITE SCREW		
-			N88-3008-46	FLAT HEAD TAPTITE SCREW		
S1			S40-1405-05	PUSH SWITCH (POWER)	MTWX	
S2			S29-2406-05	ROTARY SWITCH		
-			T42-0302-05	DC MOTOR ASSY		
D1			SLP144B	LED		
D1			S25VB10	DIODE		
Q1	2		2N5885	TRANSISTOR		
-		*	X43-1520-00	POWER SUPPLY PCB ASSY		
X43-1520-00						
C1	2		CK45E2H472P	CERAMIC 4700PF P		
C3			CK45F1H103Z	CERAMIC 0.010UF Z		
C4			CK45F1H473Z	CERAMIC 0.047UF Z		
C5			CE04W1C331M	ELECTRØ 330UF 16WV		
C6			CE04W1A470M	ELECTRØ 47UF 10WV		
C7			CK45F1H103Z	CERAMIC 0.010UF Z		
C8			CK45F1H473Z	CERAMIC 0.047UF Z		
C9	11		C90-0814-05	ELECTRØ 4700UF 25WV		
-			E23-0462-05	TERMINAL		
MC1			E40-0273-05	PIN CONNECTOR		
MC4			E40-0273-05	PIN CONNECTOR		
MC5			E40-0473-05	PIN CONNECTOR		
F1			F05-2035-15	FUSE (20A)		
-			J42-0428-05	POWER CORD BUSHING		

PARTS LIST

× New Parts

Parts without Parts No. are not supplied.

Les articles non mentionnés dans le Parts No. ne sont pas fournis.

Teile ohne Parts No. werden nicht geliefert.

Ref. No. 参照番号	Address 位 置	New Parts 新	Parts No. 部 品 番 号	Description 部 品 名 / 規 格	Desti- nation 仕 向	Re- marks 備 考
R2 ,3			RS14GB3A4R7J	FL-PROOF RS 4.7 J 1W		
R4			RD14DB2H121J	SMALL-RD 120 J 1/2W		
R8 ,9			RS14GB3A010J	FL-PROOF RS 01 J 1W		
R11 ,12			RS14GB3A331J	FL-PROOF RS 330 J 1W		
R21			RS14GB3A151J	FL-PROOF RS 150 J 1W		
VR1			R12-1429-05	TRIMMING PQT. (500)		
VR2			R12-7408-05	TRIMMING PQT. (500K)		
D1			1S1555	DIODE		
D2 ,3			U05B	DIODE		
D4			UZP19B	ZENER DIODE		
D5			UZ9.1BL	ZENER DIODE		
D6			1S1555	DIODE		
D7			UZ9.1BL	ZENER DIODE		
D8			UZ15BH	ZENER DIODE		
D9			1S1555	DIODE		
Q1			2SA562(Y)	TRANSISTOR		
Q2 ,3			2SC2458(Y)	TRANSISTOR		
Q4			2SB761(D)	TRANSISTOR		
Q5			2SC2458(Y)	TRANSISTOR		
TH1			32D27	THERMISTOR		
TH2			5TF41L	THERMISTOR		

SCHEMATIC DIAGRAM/PC BOARD

ADJUSTMENT

1. Connect the load and set the current to 15A.
2. Adjust output voltage to 13.8V ± 0.4V with VR1.

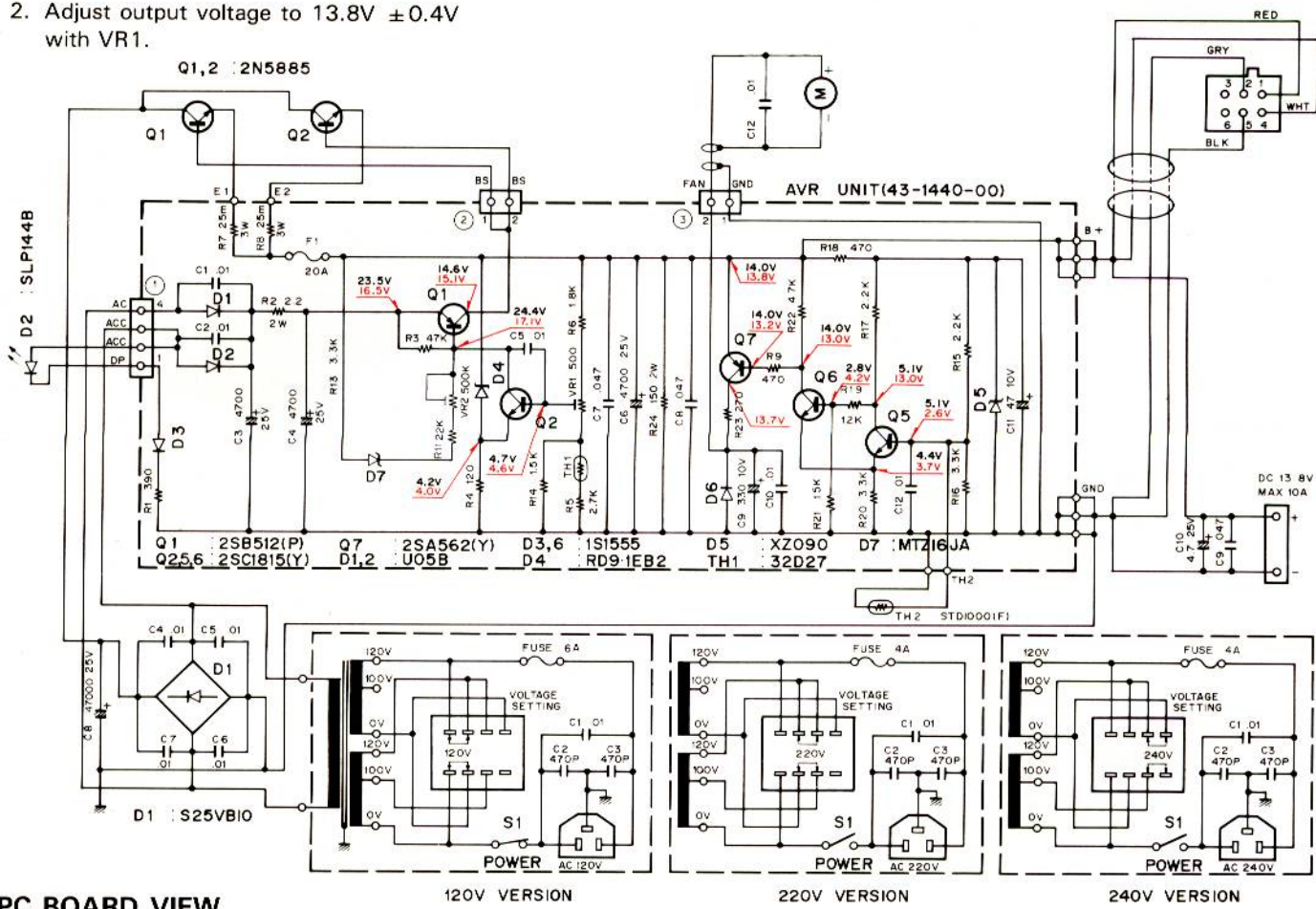

PC BOARD VIEW

AVR UNIT (X43-1440-00) Component side view

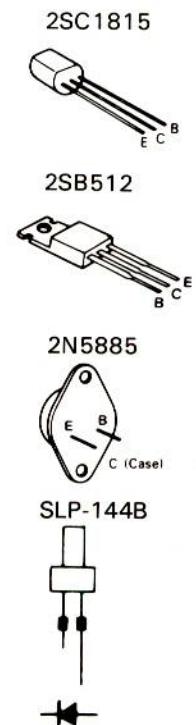
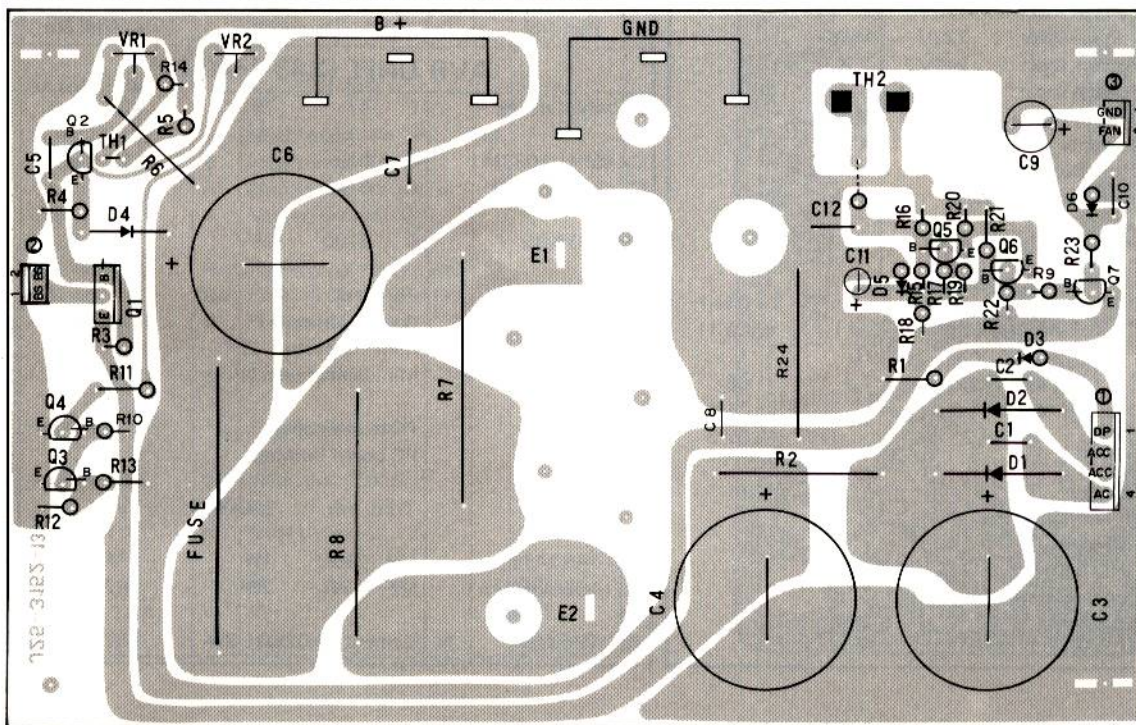

SPECIFICATIONS/PARTS LIST

SPECIFICATIONS

Input voltage: 120/220/240V AC±10%, 50/60Hz
Output voltage: 13.8V DC (standard voltage)
Output current: 20 A (25% duty cycle) 15A (50% duty cycle)
Continuous load current: 10 A max. (including external output terminal)
Output voltage fluctuation: Within ±0.7 V at AC 120V, 220V, 240V±10%
 (Load current: 15A)
 Within 0.7 V between 2—15 A load.
 (No-load output voltage: Less than 16V at 120V/220/240V, AC)
Ripple voltage. Less than 20 mV (rms) at 13.8V, output current 15A.
Power consumption: Approx. 480 W (at 120/220/240V AC, 13.8V DC, 20A)
Dimensions: 173 (6-13/16) W x 95 (3-3/4)H x 245 (9-5/8) D mm (inch)
Weight: Approx. 7 kg (15.4 lbs.)

PARTS LIST

SEMICONDUCTOR

N : New parts

Item	Re- marks	Name	Item	Re- marks	Name
Diode		1S1555	Thermistor		32D27
		S25VB10			
		U05B		TR	2N5885
Zener diode		RD9.1EB2			2SB512(P)
LED		SLP144B			2SC1815(Y)

Part No.	Re- marks	Description	Ref. No.
PS-430 GENERAL			
A01-0937-02	N	Case (upper)	
A01-0938-12	N	Case (lower)	
A20-2461-03	N	Panel	K,M,W,X
A20-2462-03	N	Panel	T
B39-0407-04		Spacer x 2	
B40-2634-04	N	Name plate	
B41-0626-14	N	Voltage sheet 120V	K
B41-0627-14	N	Voltage sheet 220V	M,W
B41-0630-04	N	Voltage sheet 240V	T,X
B42-1733-04		Voltage sheet	
B42-1770-04	N	Current indication sheet	M,T,W,X
B46-0404-00		Warranty card	K
B50-4014-00	N	Instruction manual	K,M,W,X
B50-4015-00	N	Instruction manual	T
CE04W1E4R7M	E	4.7 25V	C10
CK45E2H103P	C	0.01 500V x 4	C4-7
CK45F1H473Z	C	0.047 x 2	C9,11
C90-0865-05	N	E 4700 25V	C8
C91-0079-05		C 0.01	C1
C91-0496-05		C 470P x 2	C2,3
E18-0351-05		3P Inlet	
E20-0282-05		2P terminal plate	
E22-0472-05		Lug plate	
E23-0015-04		GND lug	
E23-0425-05		Lug terminal	
E30-1643-15		AC cord	K,M
E30-1644-15		AC cord	T

Part No.	Re- marks	Description	Ref. No.
E30-1645-05		AC cord	W
E30-1647-05		AC cord	X
E31-0500-05		Cable with plug	
F01-0786-03	N	Heat sink plate	
F01-0787-13	N	Heat sink	
F05-4022-05		Fuse 4A	K
F05-4022-05		Fuse 4A x 2	M,T,W,X
F05-6021-05		Fuse 6A x 2	K
F05-6021-05		Fuse 6A	M,T,W,X
F07-0817-04	N	Fan cover	
F09-0405-24		Fan	
H01-4451-04	N	Packing carton (inside)	K,M,W,X
H01-4452-04	N	Packing carton (inside)	T
H10-2567-02	N	Packing fixture (F)	
H10-2568-02	N	Packing fixture (R)	
H12-1319-04	N	Cushion	
H20-0276-03		Protective cover	
H25-0105-04		Protective bag	
J02-0323-05		Foot x 2	
J02-0427-04	N	Assistant foot	
J13-0033-15		Fuse holder	
J42-0403-05		Cord bushing	
J42-0434-05	N	Rubber bushing x 3	
K29-0758-04		Push knob	
L01-8166-05	N	Power transf.	
S29-2406-05		Voltage selector switch	S2
S40-1404-05	N	Power switch	S1
S59-1407-15		Thermostat	TM1
T42-0005-15		Fan motor	
X43-1400-00	N	AVR unit	

Part No.	Re- marks	Description	Ref. No.	Q'ty
AVR UNIT (X43-1440-00)				
CE04W1C470M		E 47 16V	C9	1
CK45F1H103Z		C 0.01	C1,2,5	3
CK45F1H473Z		C 0.047	C7,8	2
C90-0814-05		E 4700 25V	C3,4,6	3
E23-0022-04		Terminal		6
E23-0046-04		Square terminal		2
E40-0273-05		Mini connector 2P		2
E40-0473-05		Mini connector 4P		1
J31-0502-04		PC board collar		4
J42-0428-05		PC board bushing		4
R12-0427-05		Trim. pot. 500Ω(B)	VR1	1
RS14AB3A181J		MF 180Ω 1W	R9	1
RS14GB3D4R7J		MF 4.7Ω 2W	R2	1
R92-0663-05	N	Cement 0.025Ω 3W	R7,8	2

SPECIFICATION/PARTS LIST/PC BOARD VIEW

SPECIFICATIONS

Dimensions: W 70mm
 H 15mm
 D 35mm

Weight: 20g

TALK SPEED SELECTION

Speed is factory set at "standard" talk speed. Three different speeds can be selected.

Note: When placing the jumper, solder carefully.

Jumper place	Speed		
	Std. speed	30% more than Std.	60% more than Std.
1	X	X	○
2	X	X	○
3	X	○	X

Symbol ○, denotes the place in which a jumper wire is placed.

OUTSIDE VIEW

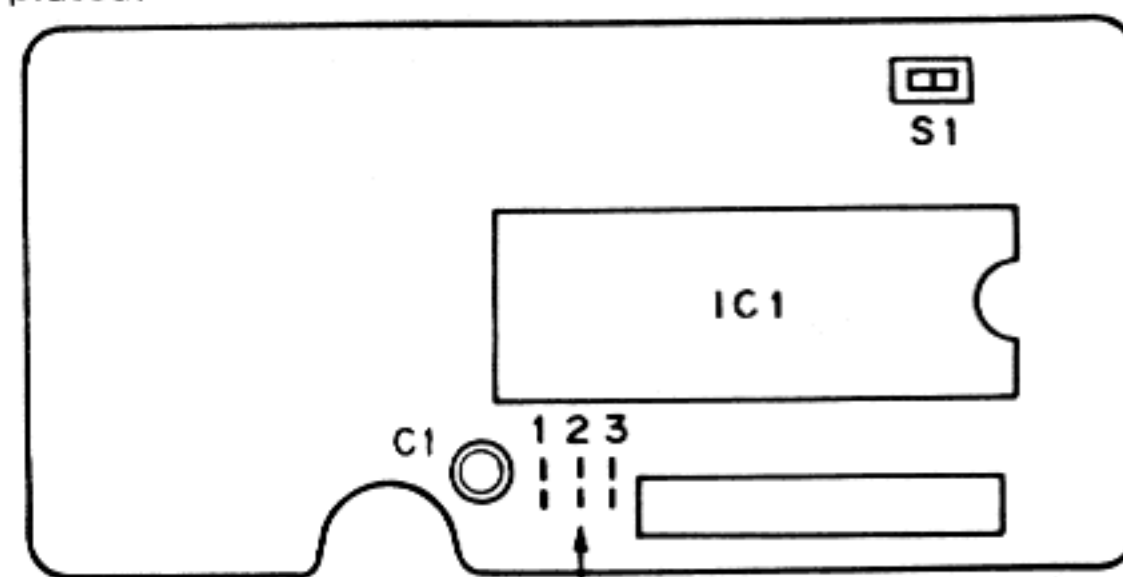
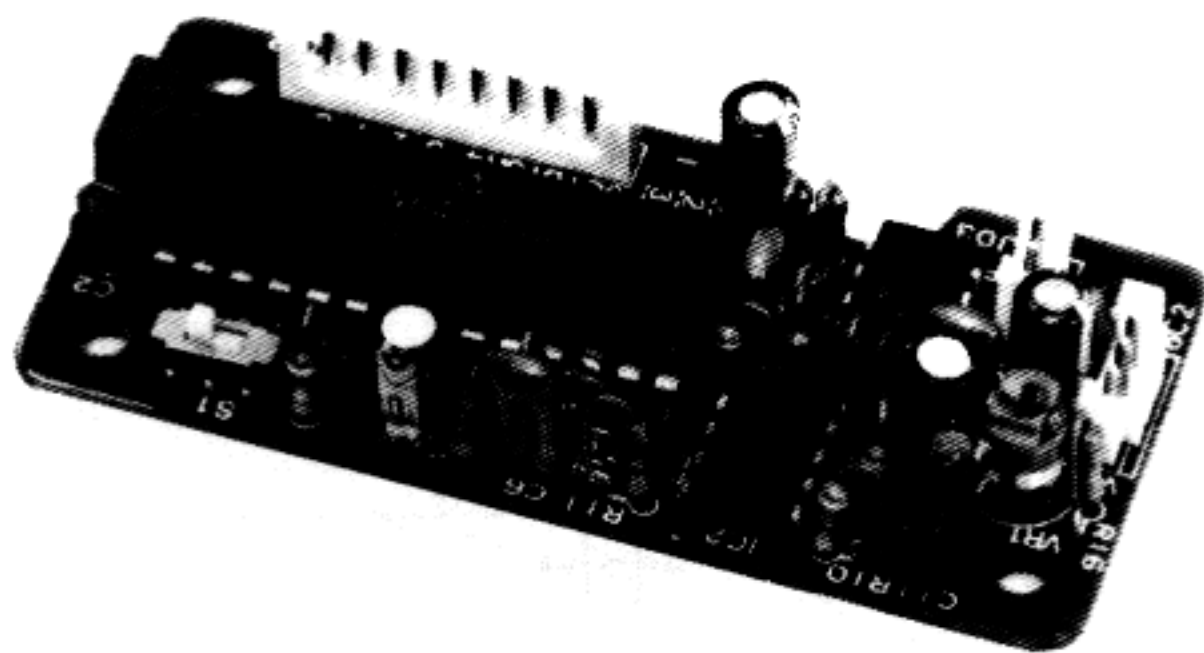

The place which a jumper wire to be placed.

PARTS LIST

Part No.	Re- marks	Description	Ref. No.
B50-4035-00	N	Instruction manual	
CC45SL1H121J	C	120P x 2	C2,3
CE04W1A470M	E	47 10V	C1,14,15
CE04W1C100M	E	10 16V	C11
CE04W1HR22M	E	0.22 50V	C12
CK45B1H221K	C	220P x 2	C7,10
CO92M1H332K	ML	0.0033 x 3	C6,8,9
CS15E1E010M	T	1 25V	C4
CS15E1V0R1M	T	0.1 35V	C5
C91-0131-05	C	0.01 (SP)	C13
E40-0273-05	Δ	Mini connector 2P	M
E40-0373-05	Δ	Mini connector 3P	M
E40-0373-05	Δ	Mini connector x 2 3P	T
E40-0873-05	Δ	Mini connector 8P	
H01-4481-03	NΔ	Packing carton (inside)	M
H01-4501-03	NΔ	Packing carton (inside)	T
H25-0029-04		Protective bag x 2	
L78-0006-05	N	Ceramic OSC	X1
N89-3006-46		Tapping screw x 4	
R12-4408-05		Trim. pot. 50kΩ	VR1
S31-1411-05	N	Slide switch	S1
AN6562	N	IC	IC2
MN6401TRA	N	IC	IC1
TC40107BP	N	IC	IC3

PC BOARD VIEW

Component side view

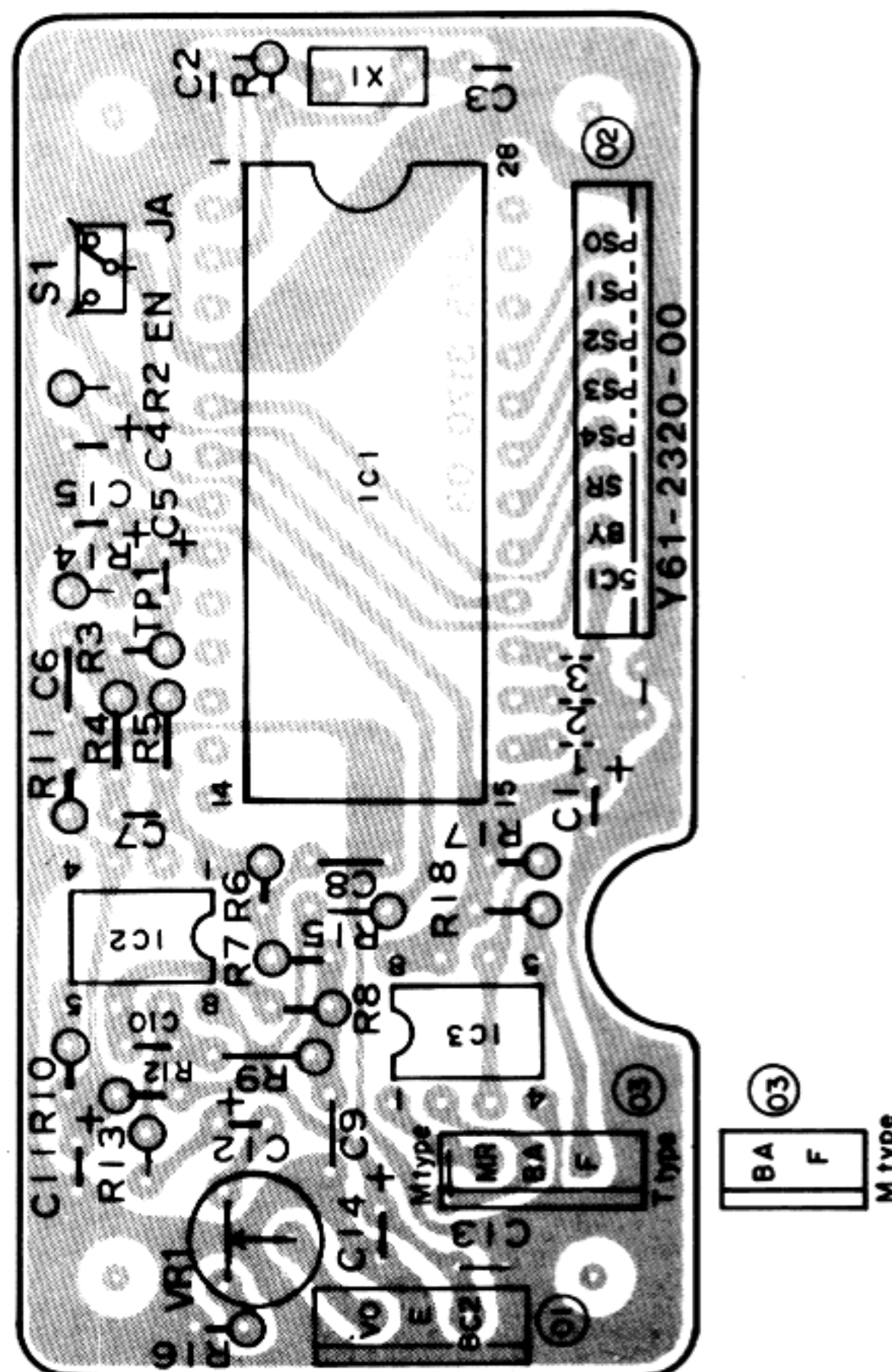

SCHEMATIC DIAGRAM

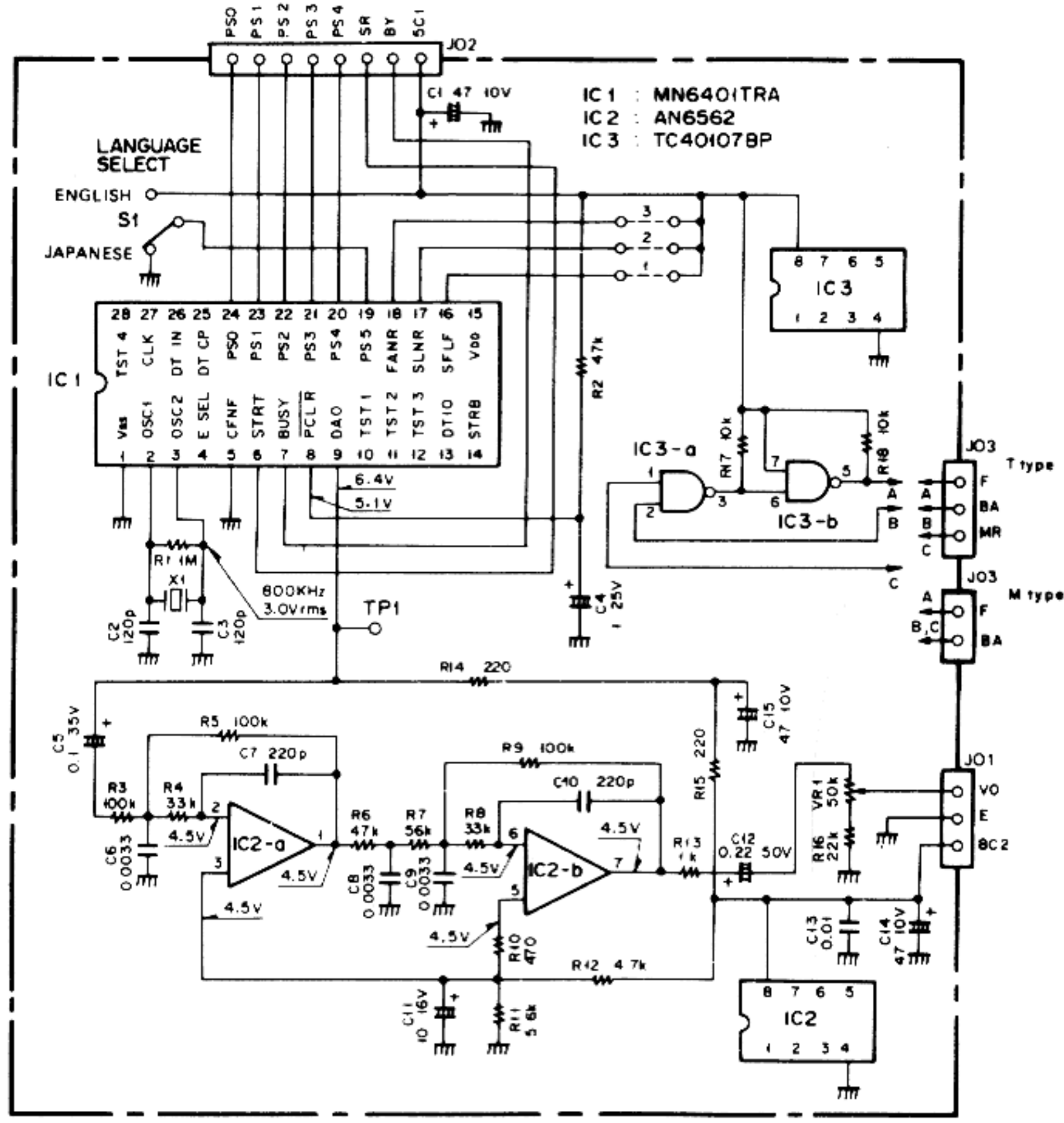

**SIDE TONE UNIT
(X59-1060-00)**

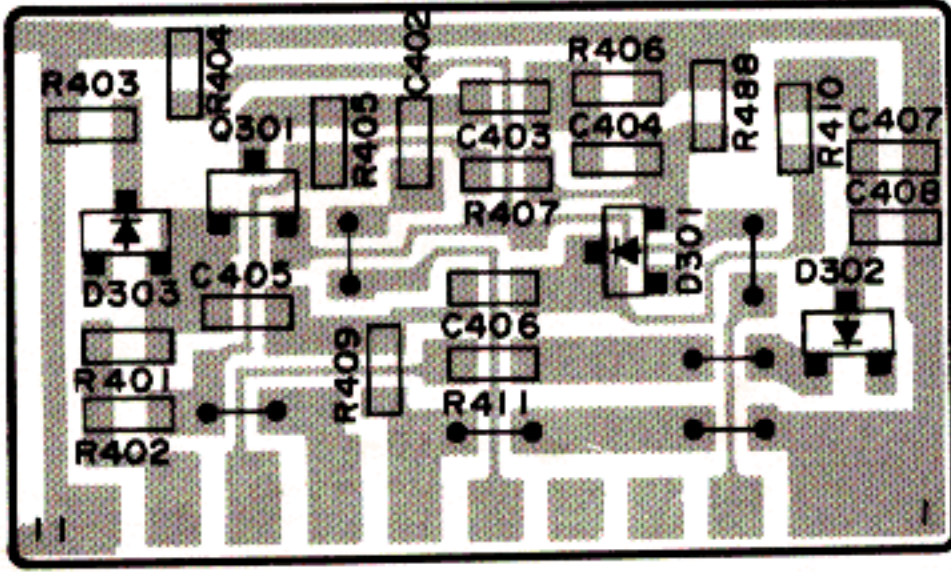

**SELECTIVITY UNIT
(X59-1070-00)**

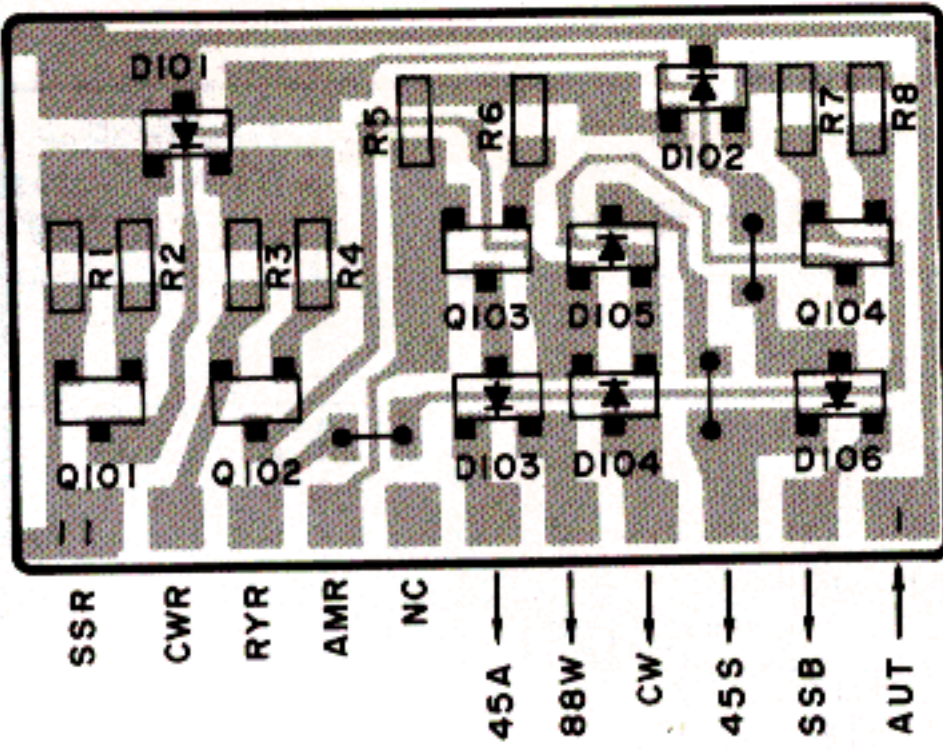

**VOX UNIT
(X59-1080-00)**

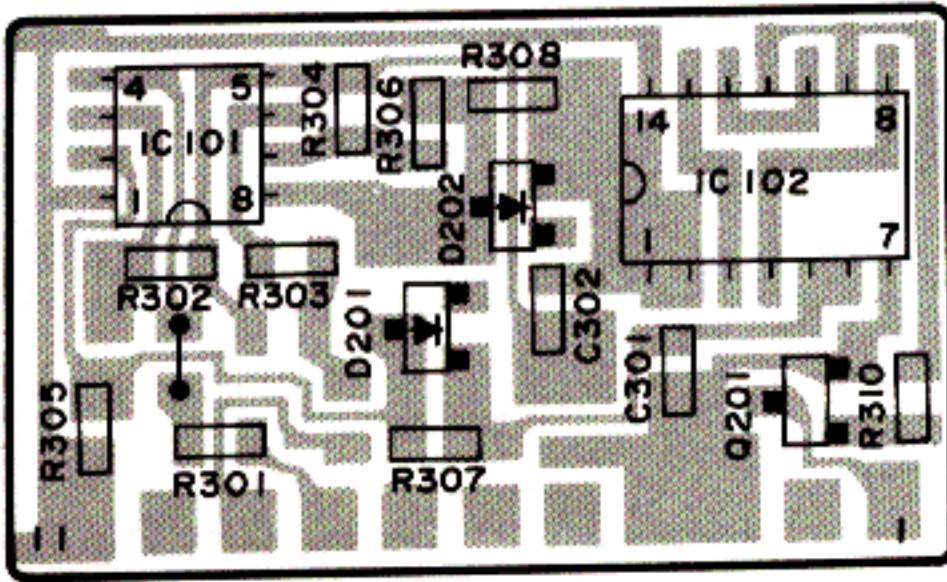

DISPLAY UNIT (X54-1870-00) (B/4)

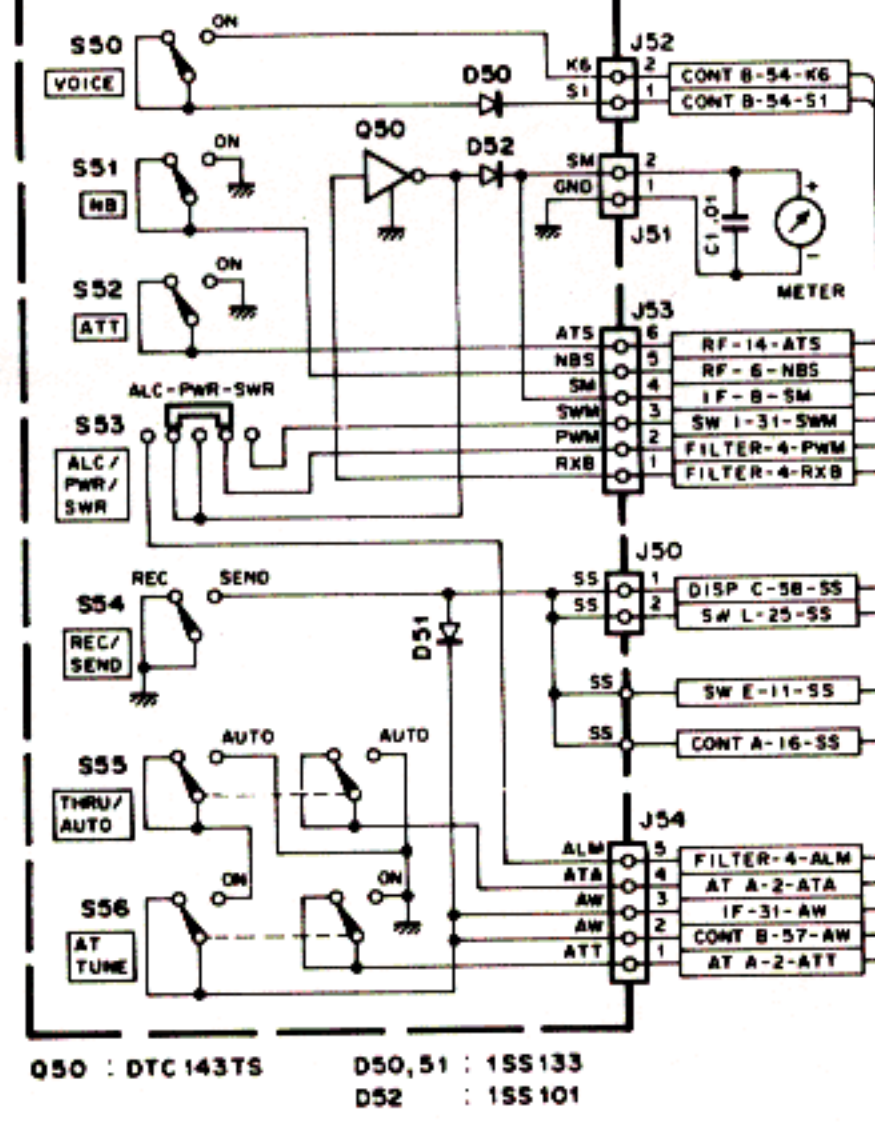

**SWITCH UNIT
(X41-1610-00) (E/14)**

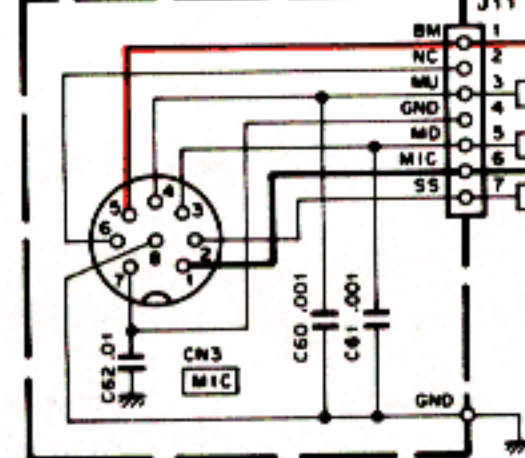

**SWITCH UNIT
(X41-1610-00) (D/14)**

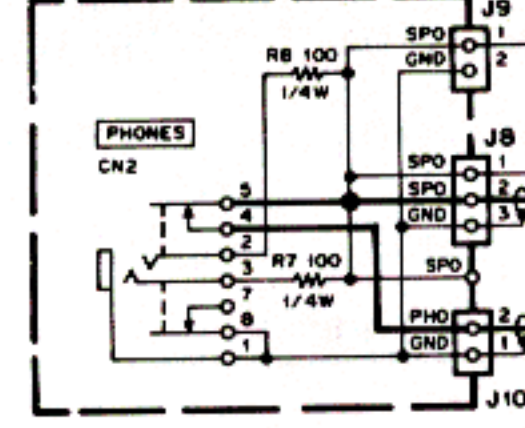

**SWITCH UNIT
(X41-1610-00) (G/14)**

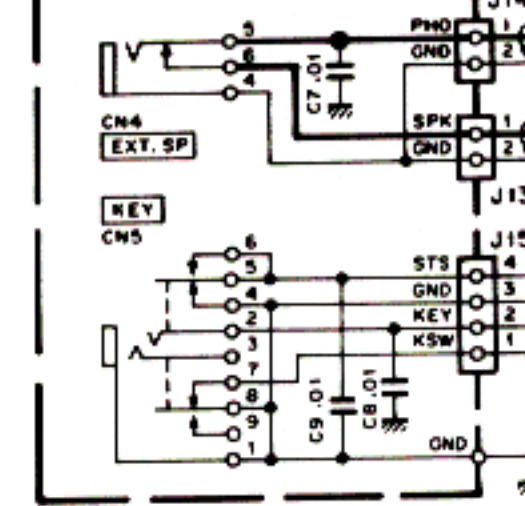

**SWITCH UNIT
(X41-1610-00) (L/14)**

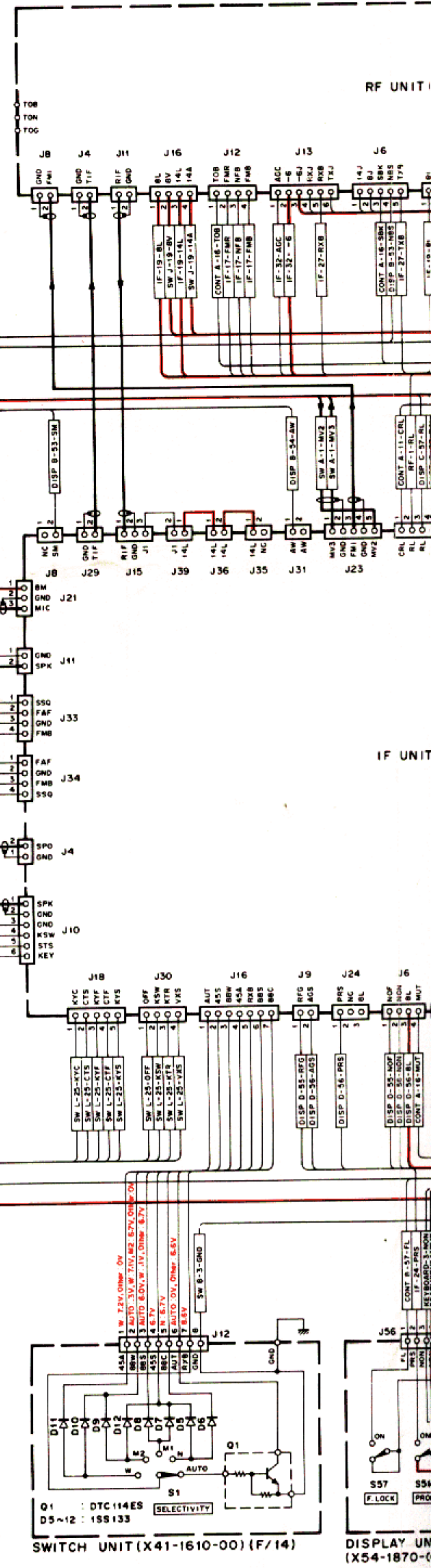
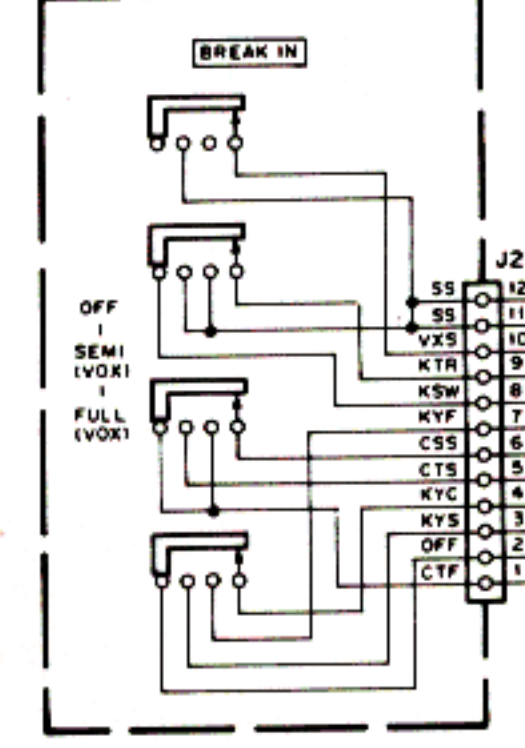

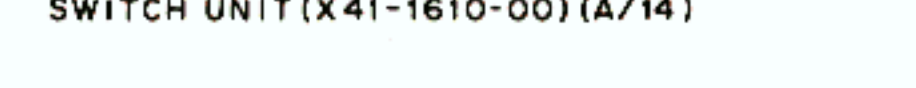
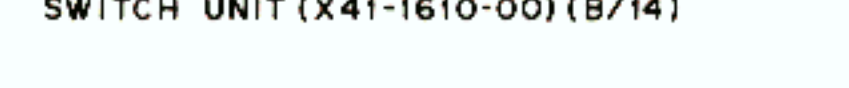
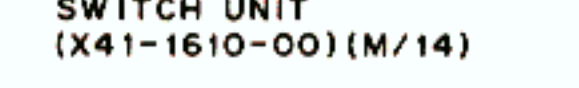
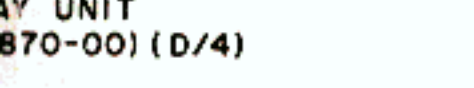
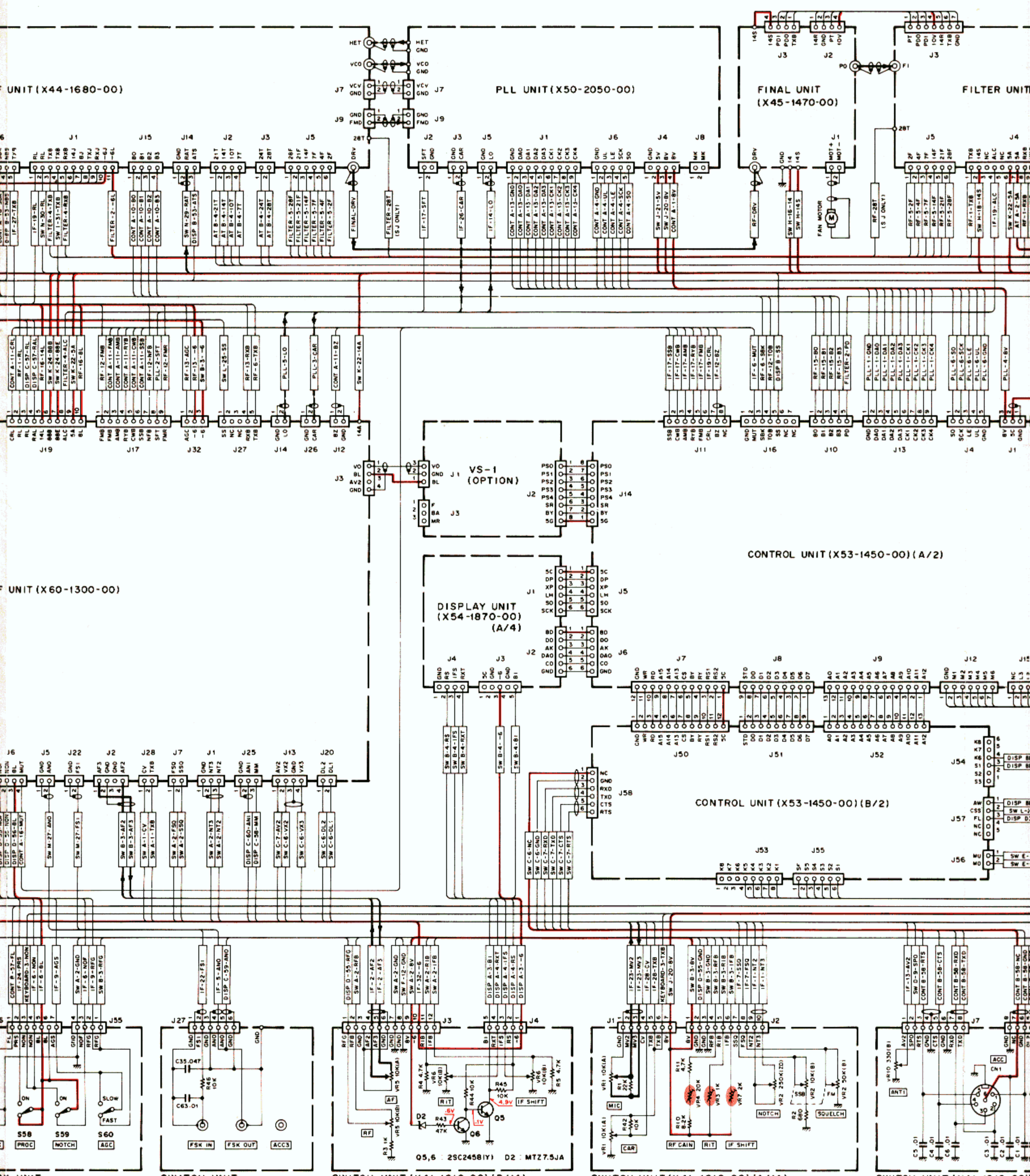

SCHEMATIC DIAGRAM TS-440S

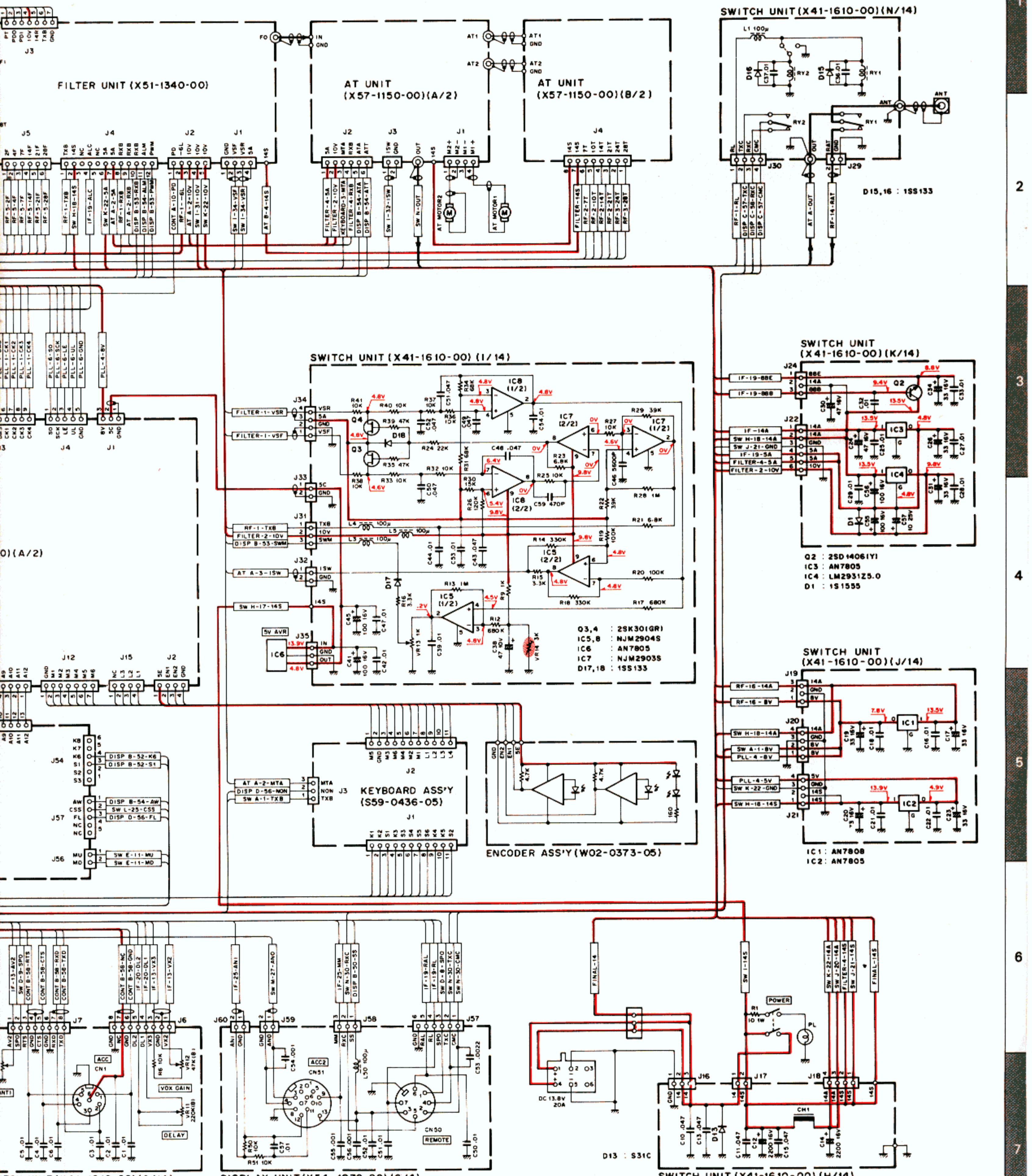

SPECIFICATIONS/PARTS LIST

MB-430 OUTSIDE VIEW

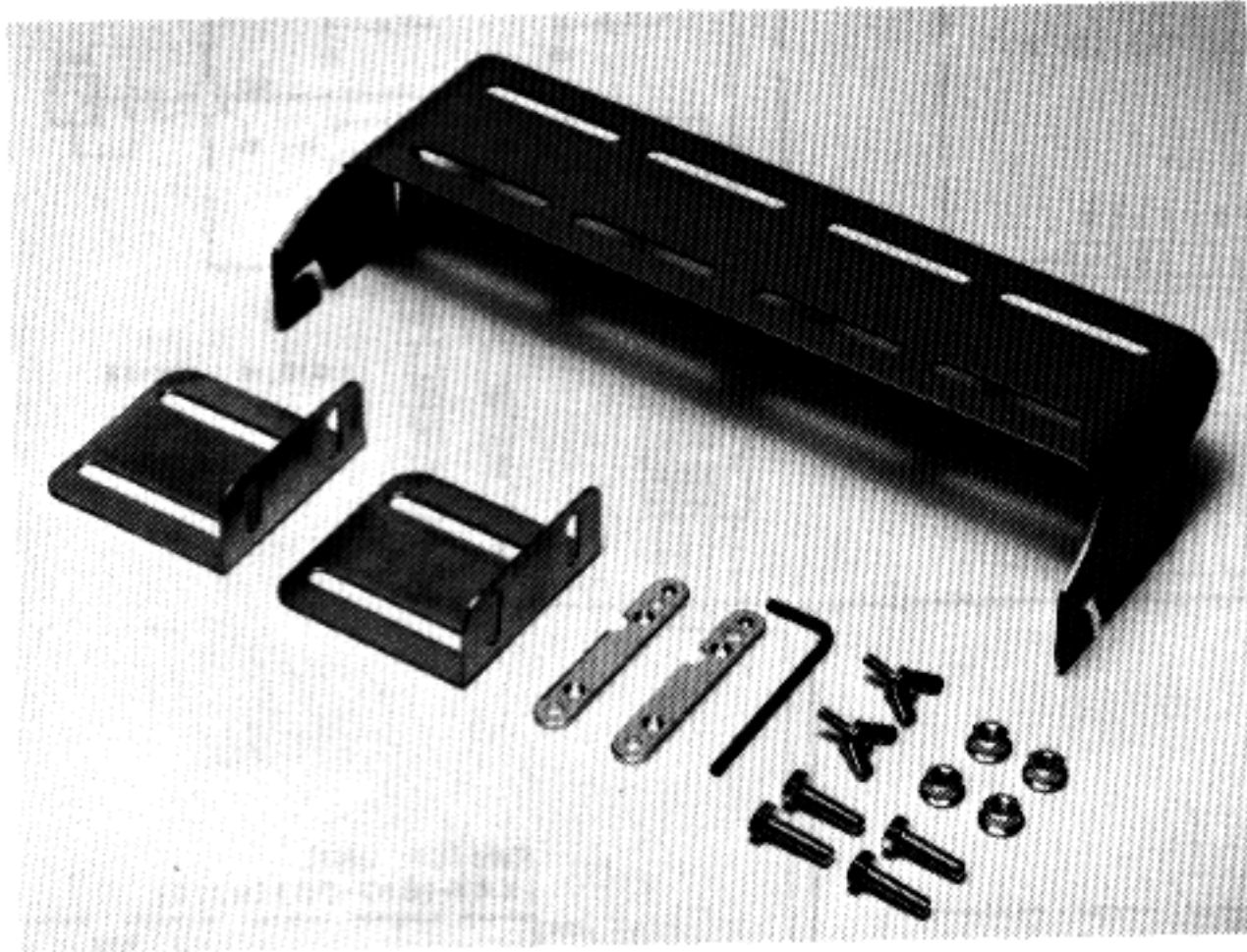

SP-430 SPECIFICATIONS

SPEAKER SIZE	3"
RATED INPUT	1.0 watts
IMPEDANCE	8 ohms
FREQUENCY RESPONSE	300 Hz to 5 kHz
DIMENSIONS	4-7/8" wide x 3-3/4" high x 9-1/3" deep (excluding feet)
WEIGHT	3.1 lbs.



SP-430 PARTS LIST

N : New parts

Part No.	Re- marks	Description	Ref. No.
A01-0942-03	N	Case (B)	
A01-0944-03	N	Case (A)	
A20-2468-03	N	Panel	K,M
A20-2469-03	N	Panel	T
A23-1431-04		Rear panel	
B04-0406-04	N	SP grill	
B07-0613-14		SP ring	
B39-0407-04		Spacer x 2	
B46-0404-00		Warranty card	K
B50-4026-00	N	Instruction manual	K,M
B50-4027-00	N	Instruction manual	T

MB-430 PARTS LIST

N : New parts

Part No.	Re- marks	Description	Ref. No.
A13-0635-03	N	Angle	
B50-4016-00	N	Instruction manual	
H01-4454-03		Packing control (inside)	
H25-0077-04		Protective bag	
H25-0098-04		Protective bag 150 x 480	
J30-0521-04	N	Spacer x 2	
N09-0007-05		Wing bolt x 5	
N09-0008-04		Hex. screw x 6	
N14-0009-04		Nut x 6	
N15-1060-46		Flat washer x 6	
N16-0060-46		Spring washer x 6	
N32-3006-46		Flat screw x 4	
N99-0309-04	N	Hex. head screw x 6	
W01-0401-04		Hex. wrench	

Part No.	Re- marks	Description	Ref. No.
E20-0208-04		Terminal plate	
E30-1629-05		SP cord	
G53-0507-04		Packing x 4	
H01-4468-04	N	Packing carton	K,M
H01-4469-04	N	Packing carton	T
H10-2513-02		Packing fixture (F)	
H10-2514-12		Packing fixture (R)	
H12-0445-04		Cushion	
H20-1407-03		Protective cover	
H25-0077-03		Protective bag Accessory	
J02-0323-05		Foot x 4	
J02-0409-04		Assistant foot	
J21-1144-14		SP mounting hardware x 2	
J21-2573-04		Foot mounting hardware x 2	
J61-0019-05		Vinyle tie	
N15-1030-46		Washer x 8	
N30-3008-46		Round screw x 4	
N35-3006-41		Bind screw x 12 Case	
N87-3006-46		Self tapping screw x 6	
N87-3008-46		Self tapping screw x 4	
T07-0224-05	N	Speaker	

FILTER

YK-88S

Item	Rating
Nominal center frequency	8830 kHz
Center frequency deviation	Within ± 150 Hz at 6 dB
Pass bandwidth	± 1.2 kHz or more at 6 dB
Attenuation bandwidth	± 1.5 kHz or more at 6 dB ± 2.2 kHz or less at 60 dB ± 3.0 kHz or less at 80 dB
Ripple	20 dB or less
Insertion loss	6 dB or less
Guaranteed attenuation	80 dB or more within ± 3 kHz or 1 MHz
Input and output impedance	600 Ω /15 pF

**Table 1 SSB crystal filter YK-88S
(L71-0208-05) Option**

YK-88SN

Item	Rating
Center frequency fo	8830 MHz
Center frequency deviation	8830 kHz ± 150 Hz at 6 dB
6 dB bandwidth	± 900 Hz or more
60 dB bandwidth	± 1800 Hz or less
Guaranteed attenuation	80 dB or more within fo ± 2.5 kHz to ± 1 MHz
Ripple	2 dB or less
Insertion loss	3 dB ± 2 dB
Input and output impedance	600 Ω /15 pF

**Table 2 SSB crystal filter YK-88SN
(L71-0220-05F) Option**

YK-88C

Item	Rating
Center frequency fo	8830.7 kHz
Center frequency deviation	fo ± 150 Hz at 6 dB
6 dB bandwidth	± 250 Hz or more
60 dB bandwidth	± 900 Hz or less
Ripple	2 dB or less
Insertion loss	6 dB ± 2 dB
Guaranteed attenuation	80 dB or more within fo ± 2 kHz to ± 1 MHz
Input and output impedance	600 Ω /15 pF

**Table 3 CW crystal filter YK-88C
(L71-0211-05) Option**

YK-88CN

Item	Rating
Center frequency fo	8830.7 kHz
Center frequency deviation	fo ± 50 Hz at 6 dB
6 dB bandwidth	± 125 Hz or more
60 dB bandwidth	± 600 Hz or less
Ripple	2 dB or less
Insertion loss	8 dB ± 2 dB
Guaranteed attenuation	80 dB or more within fo ± 2 kHz to ± 1 MHz
Input and output impedance	600 Ω /15 pF

**Table 4 CW crystal filter YK-88CN
(L71-0221-05) Option**

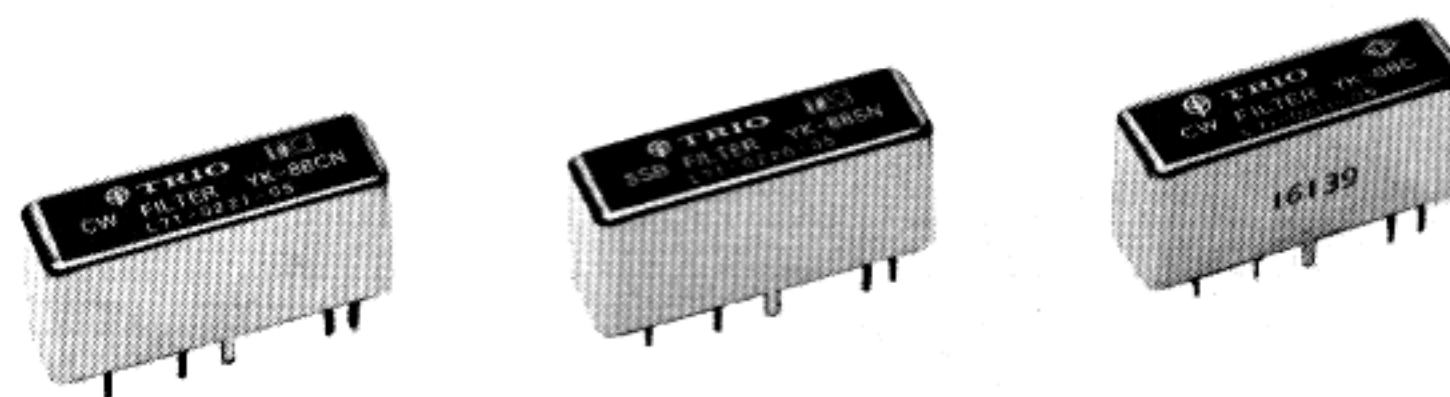

PARTS LIST

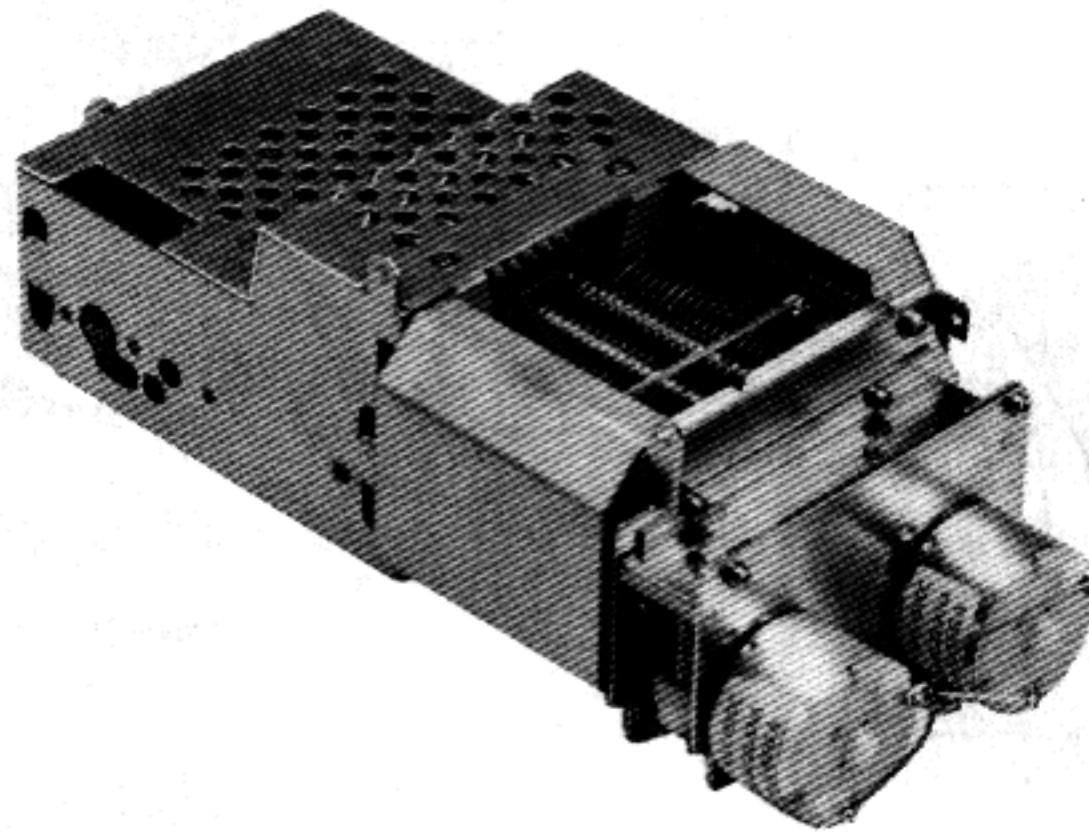

× New Parts

Parts without Parts No. are not supplied.

Les articles non mentionnés dans le Parts No. ne sont pas fournis.

Telle ohne Parts No. werden nicht geliefert.

Ref. No. 参照番号	Address 位置	New Parts 新	Parts No. 部品番号	Description 部品名 / 規格	Desti- nation 仕向	Re- marks 備考
AT-440						
-			B46-0411-00	WARRANTY CARD		
-		*	B50-8054-00	INSTRUCTION MANUAL	K	
-		*	H01-4695-04	ITEM CARTON BOX		
-		*	H03-2283-04	CARTON BOX (OUTSIDE)		
-		*	H12-1390-03	PACKING FIXTURE		
-		*	H12-1391-04	PACKING FIXTURE		
-			H25-0029-04	PROTECTION BAG		
-			H25-0705-04	PROTECTION BAG		
-			N87-3006-46	BRAZIER HEAD TAPTITE SCREW		
-			X57-1150-00	AT UNIT ASSY		

TRIO-KENWOOD CORPORATION

Shionogi Shibuya Building, 17-5, 2-chome Shibuya, Shibuya-ku, Tokyo 150, Japan

TRIO-KENWOOD COMMUNICATIONS

1111 West Walnut Street, Compton, California 90220, U.S.A.

TRIO-KENWOOD COMMUNICATIONS

DIVISION OF TRIO-KENWOOD ELECTRONICS, GmbH

Rembrüker str. 15, 6056 Heusenstamm West Germany

TRIO-KENWOOD ELECTRONICS, N.V.

Leuvensesteenweg 504, B-1930 Zaventem, Belgium

TRIO-KENWOOD (AUSTRALIA) PTY. LTD. (INCORPORATED IN N.S.W.)

4E. Woodcock Place, Lane Cove, N.S.W. 2066, Australia