

TR-2200G

 KENWOOD

2 METER FM HANDY TRANSCEIVER



OPERATING MANUAL

The TR-2200G transceiver is a 144 MHz-band handy transceiver, designed to reduce size and weight. The type of emission is F3. 12 channels are used for transmission and reception in the crystal control system.



TR-2200G OPERATING MANUAL

CONTENTS

SPECIFICATIONS.....	3
SECTION 1. PRIOR TO OPERATION	4
SECTION 2. CONTROLS.....	4
SECTION 3. INSTALLATION	6
SECTION 4. OPERATION	7
SECTION 5. PRECAUTION	10
BLOCK DIAGRAM	12
CHASSIS VIEW (1)	13
CHASSIS VIEW (2)	14
SCHEMATIC DIAGRAM	15

SPECIFICATIONS

GENERAL

SOLID-STATE COMPONENTS

TRANSISTORS	24
FET	1
ICs	3
DIODES	22

POWER SUPPLY

EXTERNAL	10.4V ~ 15.2V (standard 13V DC)
GROUND	Negative ground

POWER CONSUMPTION

TRANSMISSION	Approximately 420 mA at 13.0V
RECEPTION	Approximately 55 mA at 13.0V

DIMENSIONS

WEIGHT	1.8 kg (including 10 nickel-cadmium cells and microphone)
--------	---

TRANSMIT SECTION

FREQUENCY	12 channels in 144 to 146 MHz
TYPE OF EMISSION	F3
RF OUTPUT POWER	1.0 watts at 13V DC
MODULATION	Variable reactance phase shift
MAX. FREQ. DEVIATION	± 7.5 kHz
MULTIPLICATION	12 times
FUNDAMENTAL FREQ.	12 MHz band
SPURIOUS RADIATION	Less than 1m watts
ANTENNA IMPEDANCE	50 Ω
MICROPHONE	Dynamic type with PTT switch, 500 Ω

RECEIVE SECTION

FREQUENCY	12 channels in 144 to 146 MHz
TYPE OF EMISSION	F3
CIRCUITRY	Double superheterodyne system
SENSITIVITY	Less than 1 μV for 20 dB S/N
PASS-BAND WIDTH	More than 16 kHz at 6 dB down
SELECTIVITY	Less than 32 kHz at 50 dB down
FILTER	Ceramic filter
INTERMEDIATE FREQ.	1st IF 10.7 MHz 2nd IF 455 kHz
AUDIO OUTPUT	More than 0.5 watts (10% distortion)
AUDIO OUTPUT (MAX.)	More than 0.7 watts

Note: Circuits and ratings are subjected to modification due to technical improvement.

SECTION 1. PRIOR TO OPERATION

1-1 UNPACKING

Carefully unpack the TR-2200G transceiver and check that the following accessories are included.

1 Carrying case	1
2 Carrying strap	1
3 Battery holder (for 6 cells, incorporated in the transceiver)	1
4 Same (for 4 cells, one incorporated in the transceiver)	2
5 Charging power pack unit	1
6 External DC power cord	1
7 Phone plug	1
8 Microphone (dynamic)	1
9 Operating manual	1



Fig. 1 Accessories

SECTION 2. CONTROLS

2-1 CONTROLS & THEIR FUNCTION

- Whip Antenna**
Use this built-in antenna fully stretched.
- POWER/VOL Knob**
This provides power on-off and source volume control. The set is switched off when it is turned fully counterclockwise (OFF position).
- Meter**
Serves as a power voltage checker, transmission indicator, or an S-meter (Input Signal Intensity Meter). Switching over between the latter two functions is performed automatically. It serves as an input signal intensity meter during reception.
- SQU/B. CH Knob**
This switch is used for checking battery voltage and also for squelch adjustment. When turned fully counterclockwise, battery or external power voltage is indicated. When turned clockwise, the squelch functions almost in the mid-point of the scale.
- Channel Selector**
There are 12 channels. The selected channel is indicated in the window.
- CALL Channel Switch**
Depressing this switch makes the signal emitted, modulated by the tone OSC (1,750 Hz), for calling a relay station.
- MIC Connector**
To be connected with the accessory microphone. Depress the microphone switch for the transmission mode.
- Case Holding Snap**
Unhook before dismantling the case from the unit.
- Battery Charger & External DC input**
To be connected to the accessory charging power pack unit when the nickel-cadmium battery cells require charging.



Fig.2 Front Panel

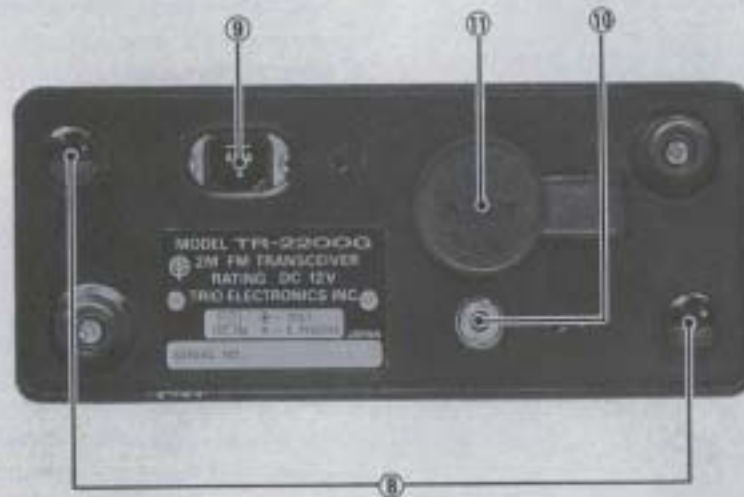

Fig. 3 Rear Panel

10 External Speaker Connector

Connects accessory phone plug in operation of set with an external speaker.

11 External ANT. Connector

To be connected with an external antenna when the transceiver is used as a fixed station.

SECTION 3. INSTALLATION

3-1 BATTERY INSTALLATION

1. Pull the case holding snaps at the bottom of the transceiver casing to expose the battery holders (Fig. 4).
2. When employing manganese or alkaline battery cells (1.5V per cell), load 8 cells into the two 4-cell holders. When nickel-cadmium cells (1.2V per cell) are used, a 4-cell holder and an extra 6-cell holder should be used to accommodate 10 cells. They should be carefully loaded in correct polarity which is marked on the holders.
3. Hook the battery snap connectors on the battery holders and return them into the transceiver casing, as illustrated in Fig. 4. Push the case holding snaps to the fixing positions.

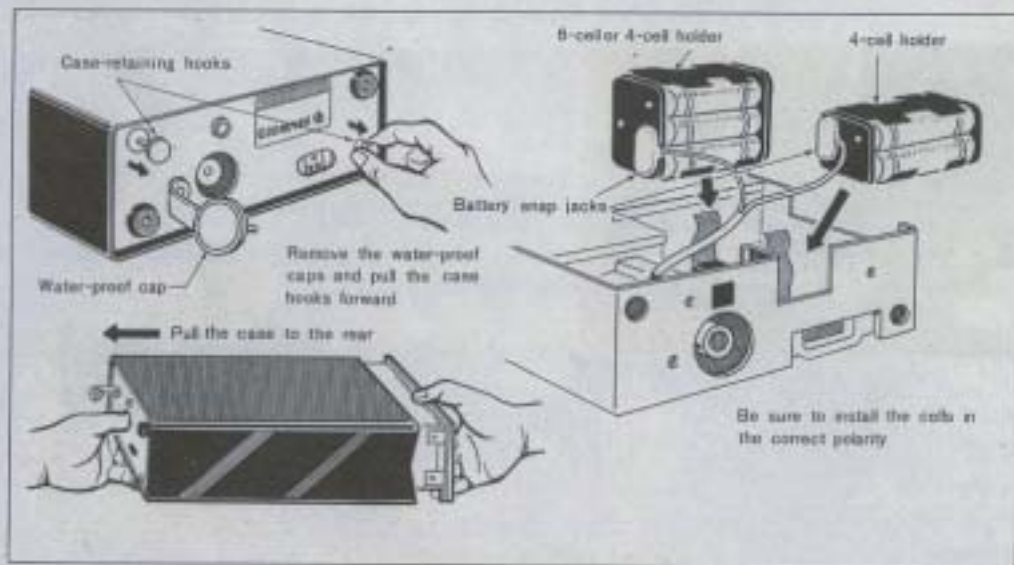

Fig. 4 Battery Installation

3-2 VOLTAGE CHECK

Voltage can be checked in the following ways:

1. Turn the SQU/B. CH knob fully counterclockwise to the B. CH position.
2. Turn the Power/VOL knob clockwise to turn the power on. Then the meter will deflect.
3. If the deflection is within the shadowed area as shown in Fig. 5 (top left), this means that the battery has expired and the battery cells must be replaced or charged (for nickel-cadmium battery). When an external power supply is connected, the meter will automatically indicate the external power voltage.

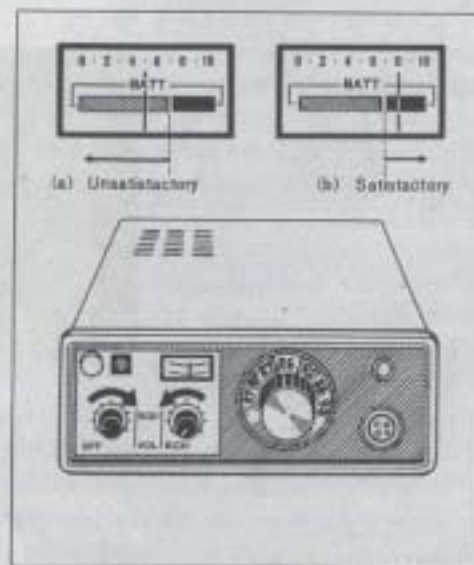

Fig. 5 Voltage Check

SECTION 4. OPERATION

4-1 RECEPTION

1. Fully stretch the whip antenna.
2. Turn the SQU/B. CH knob counterclockwise to a point just before it clicks into the B. CH position.
3. Turn the Power/VOL knob clockwise to power on and turn it further until noise can be heard.
4. Set the channel selector to any of channels R6, R8, or A.
All preparatory steps for reception of the FM signal are now complete. The meter will indicate the intensity of the incoming signal. With an input of about 20 dB, the meter will swing full scale. The volume may be increased by turning the Power/VOL knob clockwise.
5. Quenching background noise using SQU/B. CH knob.
In the absence of a receiving signal, the FM receiver will produce background noise, which is very annoying during stand-by. This noise can be suppressed by turning the SQU/B. CH knob clockwise until the noise disappears. Squelch will be triggered off only when a signal comes. Intermittent operation of the squelch indicates the necessity of turning the knob further clockwise.

4-2 TRANSMISSION

1. Stretch the whip antenna to its full length. Then set the channel selector to the desired channel.
2. The mode of transmission is obtainable by depressing the push-switch on the microphone. The level meter will indicate around 8. This meter will deflect widely if the antenna is not fully extended. Note, however, that this is not the correct way of use and will result in an overload in the final-stage power transistor, often causing damage. A withdrawn antenna or short-circuit antenna system will also cause similar trouble.

4-3 EXTERNAL SPEAKER

An external speaker may be used in conjunction with the TR-2200G transceiver using the accessory phone plug. The output impedance for the external speaker is 8 ohms. The output circuit employs an OTL system, which requires extra precaution against short-circuit. Construction of the phone plug is illustrated in Fig. 6.

4-4 EXTERNAL ANTENNA

When an external antenna is to be connected to the transceiver, the built-in whip antenna must be completely withdrawn into the casing. A well-turned 144 MHz antenna should be connected to the external ANT connector through a coaxial cable.

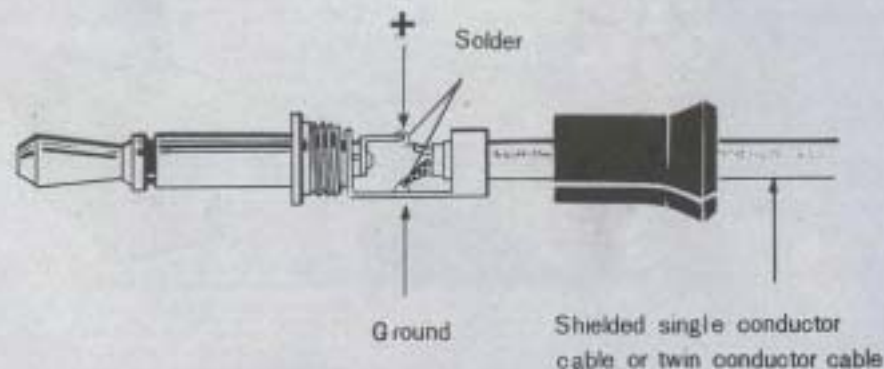

Fig. 6 External Speaker Plug Connections

4-5 EXTERNAL POWER SUPPLY

External power supply requires a current capacity of more than 0.5A at 13V DC preferably with voltage stabilizer. When the transceiver is connected to an external power supply, there will be a voltage drop of 0.8V due to a diode which is provided for preventing reverse connection. Consequently, the voltage rating is 13V DC. When connected to the battery supply, the transceiver operates at 12V DC $\pm 20\%$.

* **Note:** The internal battery cells need not to be removed during external power operation since the connection of the external DC power plug automatically disconnects the internal battery from the circuit.



Fig. 7 Polarity of External Power Cord

4-6 BATTERY CHARGING

The TR-2200G transceiver is provided with an accessory battery charger for rechargeable nickel-cadmium cells. Connections for the accessory charging power pack unit are shown in Fig. 8. Manganese or like dry cells cannot be recharged. The lowest level of the rechargeable nickel-cadmium battery is 10V or when the meter deflection falls between the black and red zone.

To charge the battery, set the Power/VOL knob to OFF and connect the charging connector with the charging power pack unit. Charging is started when the plug of the power pack unit is connected to a 220V AC commercial power outlet. The charging time required for a battery in this state will be 14 to 16 hours for full (100%) recovery. It takes, however, about 20 hours for initial charging. A fully charged battery is indicated by the meter deflection to the mid-point of the normal black zone when the Power/VOL knob is set to ON and the SQU/B. CH knob is set to B. CH position.

Continued overcharging, say, for more than 12 hours is harmful to the battery. Acceptable charging temperature ranges between 0 and 45°C.

Use of an external power supply will not hinder charging as long as the charging power pack unit is connected.

* **Note:** The accessory charging power pack unit cannot effect transmission and reception.

4-7 CONSTRUCTION OF CHANNELS

In channel R6, R8, and A, crystals are provided as tabulated below. Other channels are empty channels. If expansion of channels is required, refer to 4.8 CHANNEL EXPANSION.

4-8 CHANNEL EXPANSION

Channel expansion can be done in the following way. Draw out the case as described in 3.1 BATTERY INSTALLATION. Then remove two sliding pieces as illustrated in Fig. 9. In this state a plastic cover

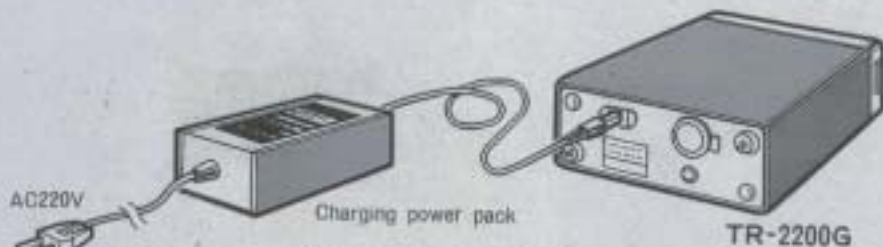

Fig. 8 Battery Charging

Channel Numbers and Frequencies

CHANNEL	TRANSMIT FREQ. (MHz)	RECEIVE FREQ. (MHz)
R6	145.150	145.750
R8	145.200	145.800
A	145.500	145.500

for the printed circuit block can be dismantled. The position for a new crystal is marked on the plastic cover, so that it can be put in the correct position. Never insert it in a wrong position.

Install the crystals in position according to the indications on the plastic cover. Usable type of crystal is HC 25/U. Crystal oscillating frequency is the twelfth of transmit frequency, because of the multiplication (12 times) in this set.

Crystal (for reception) oscillating frequency calculated as under.

$$f_o = \frac{f_r - 10.7}{3}$$

f_r : Desired receive frequency (MHz)

f_o : Crystal oscillating frequency (MHz)

Third overtone

The newly installed crystal requires frequency adjustment only in the transmitter circuit. A counter may be required for precise adjustment. However in practical usage, the circuit can be accurately adjusted with the aid of another distant station turned in to the same channel so that the emitted signal from this station can be heard clearly. When a crystal has been mounted, the plastic cover and the slide pieces (2 pcs.) must be returned to their former positions.

(Frequencies of the built-in crystals may change according to destination.)

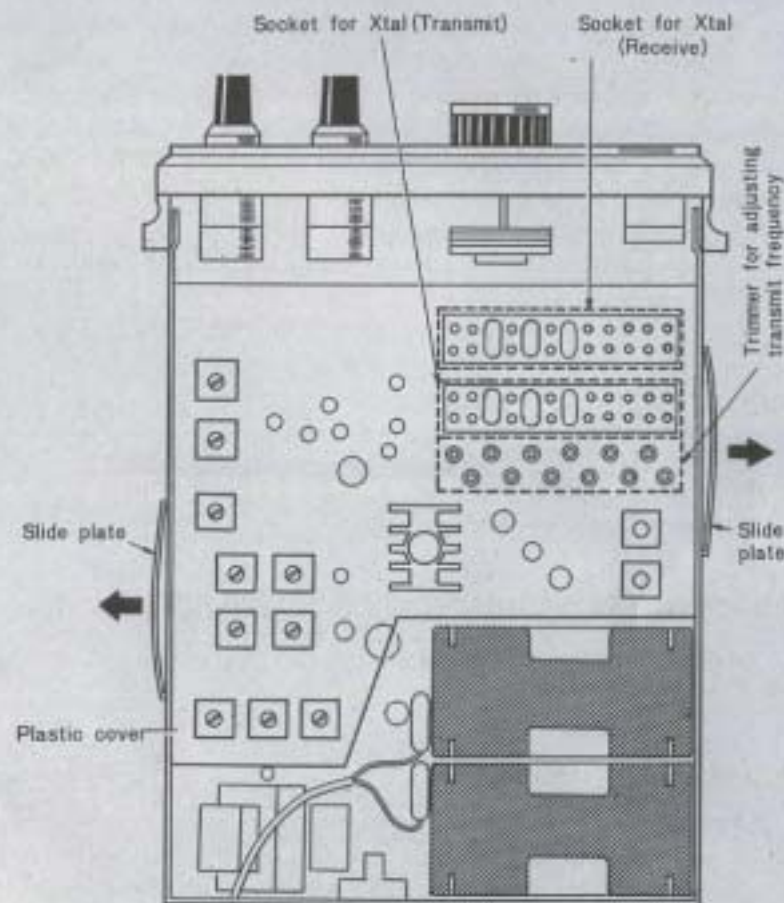

1. Remove the Slide plates
2. Remove the batteries
3. Remove the plastic cover
4. Xtal installation position referred to indications on the plastic cover

Fig 8 Expansion of Channels

SECTION 5. PRECAUTION

5-1 TELEVISION INTERFERENCE

The TR-2200G transceiver is equipped with a low-pass filter and adequately shielded to prevent television interference (TVI). An FM signal emitted close to a TV set may interfere with it, if the TV signal in this area is weak. Therefore, the transceiver should be kept as far away as possible from the TV antenna. Two closely located transceivers will also produce a similar interference.

5-2 GROUND POLARITY

The transceiver is negatively grounded on the chassis. Caution is required especially when an external power supply is employed since a connection in wrong polarity will damage transistors and diodes.

5-3 FLOATING OPERATION WITH BATTERY CHARGER

Floating operation with the battery being charged cannot be effected. Use external power supply or battery.

5-4 NICKEL-CADMIUM BATTERY

The rechargeable nickel-cadmium battery cells will cease to function when the per-cell emf drops to 1.0V. This corresponds to the fact that the remaining energy is 1/10 of the full charge. One subsequent full charge will provide an additional 3 hours or more of operation when the battery drain is in 1-minute transmission and 3-minute reception cycles. Since the nickel-cadmium battery cells have an extremely low internal resistance, short-circuit or reverse-polarity connection will generate heat, which will result in damage. Care should be taken when

installing the cells in battery holders. A nickel-cadmium cell will serve for more than 300 dischargings when properly operated. This long service life is economically advantageous since cost saving is more than 10 times that of a regular manganese cell.

5-5 VEHICLE OPERATION

The TR-2200G transceiver may be operated in an automobile utilizing the 12V DC vehicle power. Since mobile power, however, will generate ignition noise in reception, use of a filter as shown in Fig. 10 is recommended.

5-6 ACCOMMODATION OF MICROPHONE

The microphone can be accommodated in the case. In this case the connector should be disconnected. If unreasonable stress is exerted near the connector, the cord may be damaged.

5-7 OPERATION IN LOW-TEMPERATURE AREAS

The circuit design of this transceiver will insure normal operation at a temperature between -20°C and $+50^{\circ}\text{C}$. When the temperature falls below -20°C , however, covering the set with a protective bag is recommended to maintain the temperature suitable for normal battery service.

A regular manganese dry cell requires a higher operating temperature than a nickel-cadmium cell, and performance will suddenly drop at a temperature below 0°C . Nickel-cadmium cells are recommended for use in an extremely cold or freezing zone.

5-8 MATCHING WITH EXTERNAL ANTENNA

When an external antenna is used, deficiency in the emission of waves may be caused by inadequate matching between antenna and transmitter, even if the transceiver is no defective. This mismatching can be checked by measuring the standing-wave ratio with an SWR meter. If the measured value is more than 3, length of the antenna element should be adjusted until the value approaches 1. Inadequate SWR setting will result in television interference.

5-9 BATTERY INSTALLATION

Poor contact between cells and holder and between holder and snap connector should be eliminated.

5-10 MISCELLANEOUS

Regarding unclear points or troubleshooting, please make inquiries to our service stations. Unless required, trimmer capacitors must not be turned carelessly.

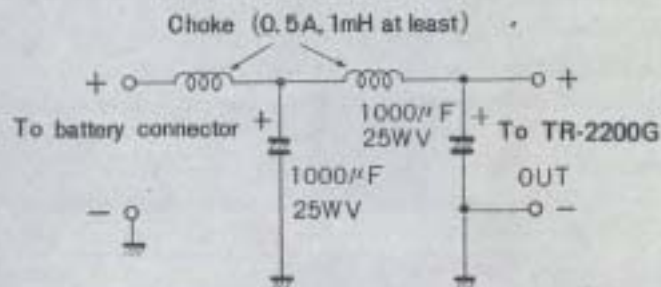
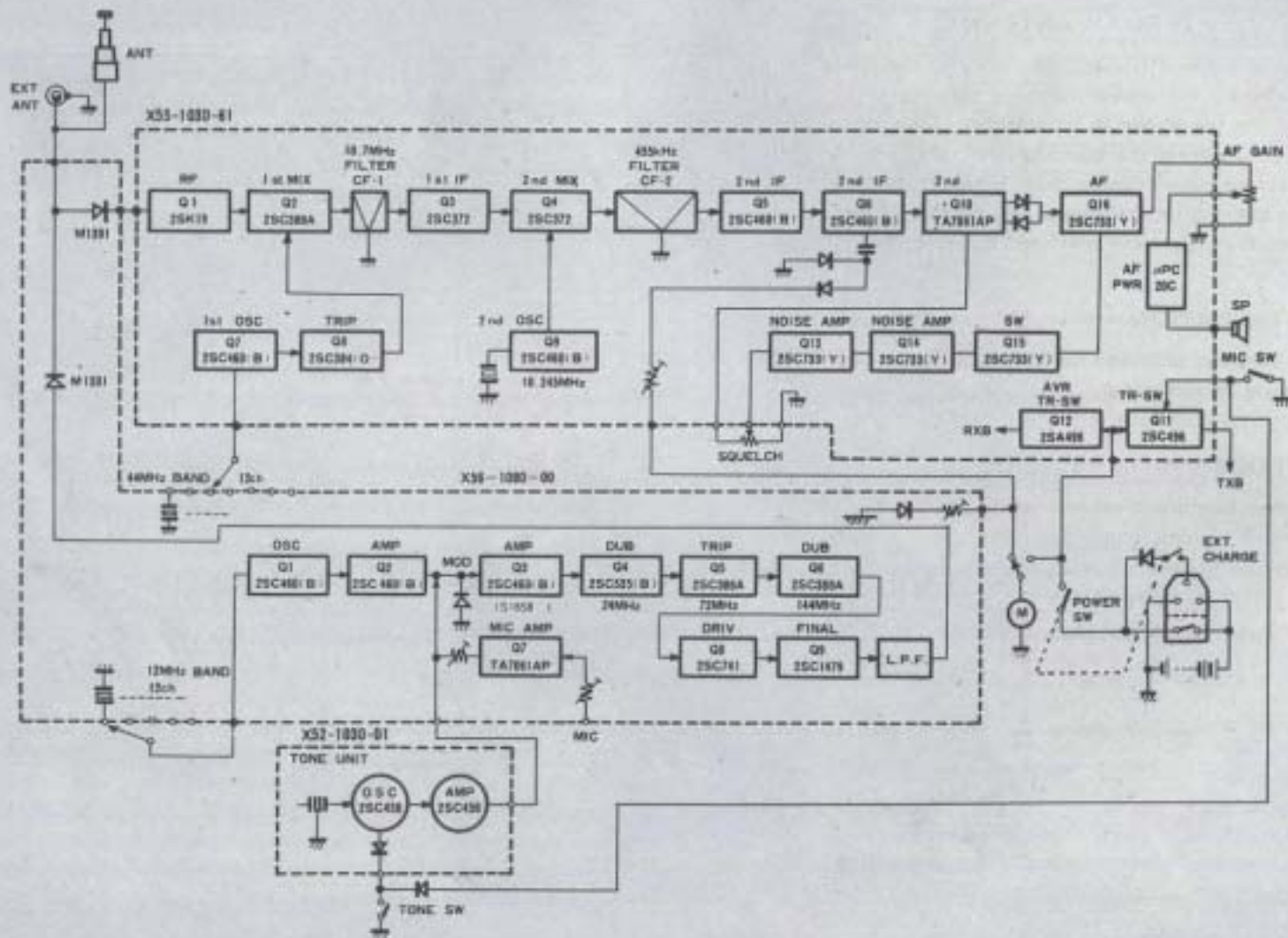

Fig. 10 Preventing Circuit for Ignition Noise

BLOCK DIAGRAM



CHASSIS VIEW (1)

SCHEMATHEEK
 Beh. T. Hultermans
 Postbus 4228
 5804 EE Eindhoven

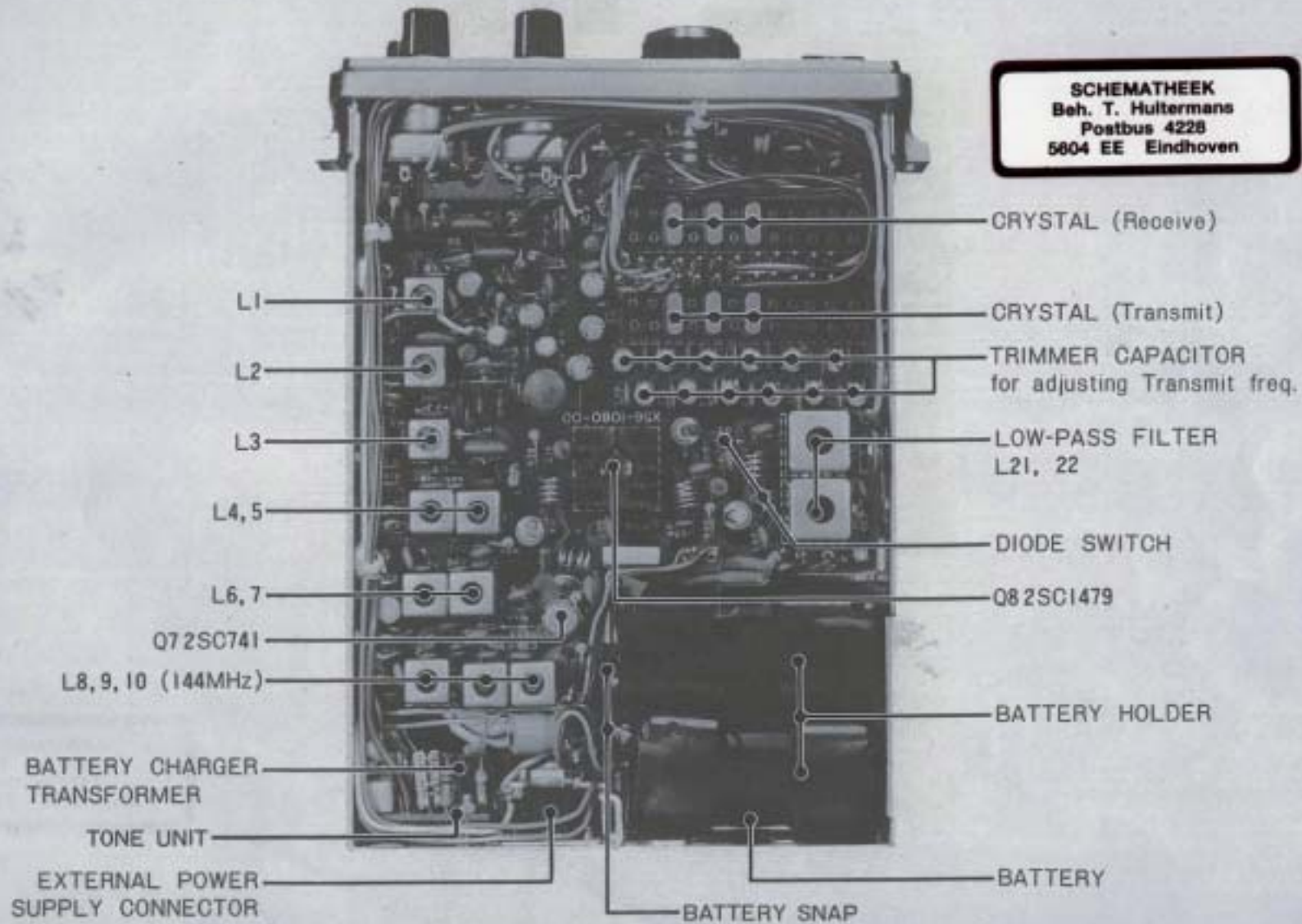

CHASSIS VIEW (2)

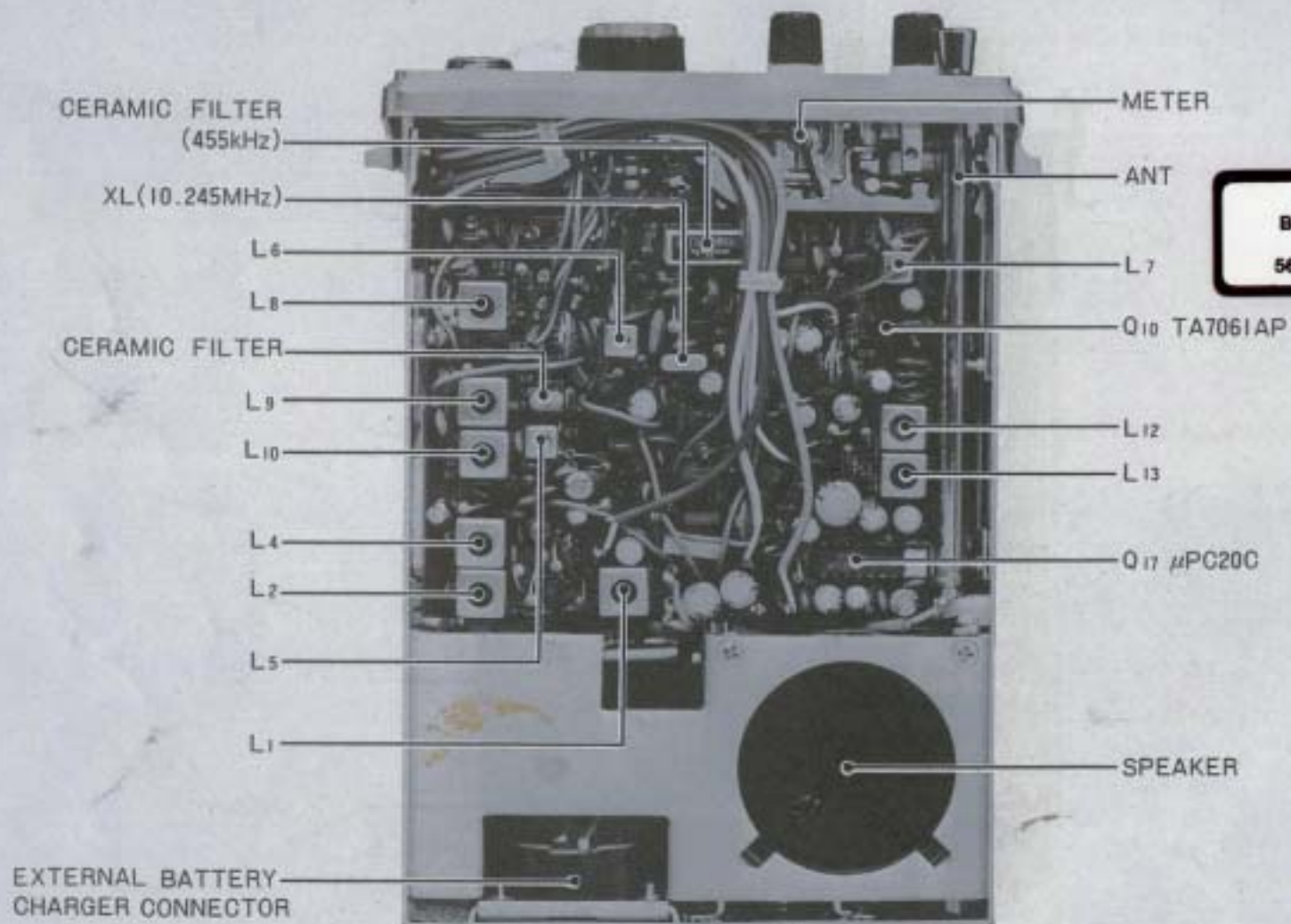

SCHEMATIC DIAGRAM

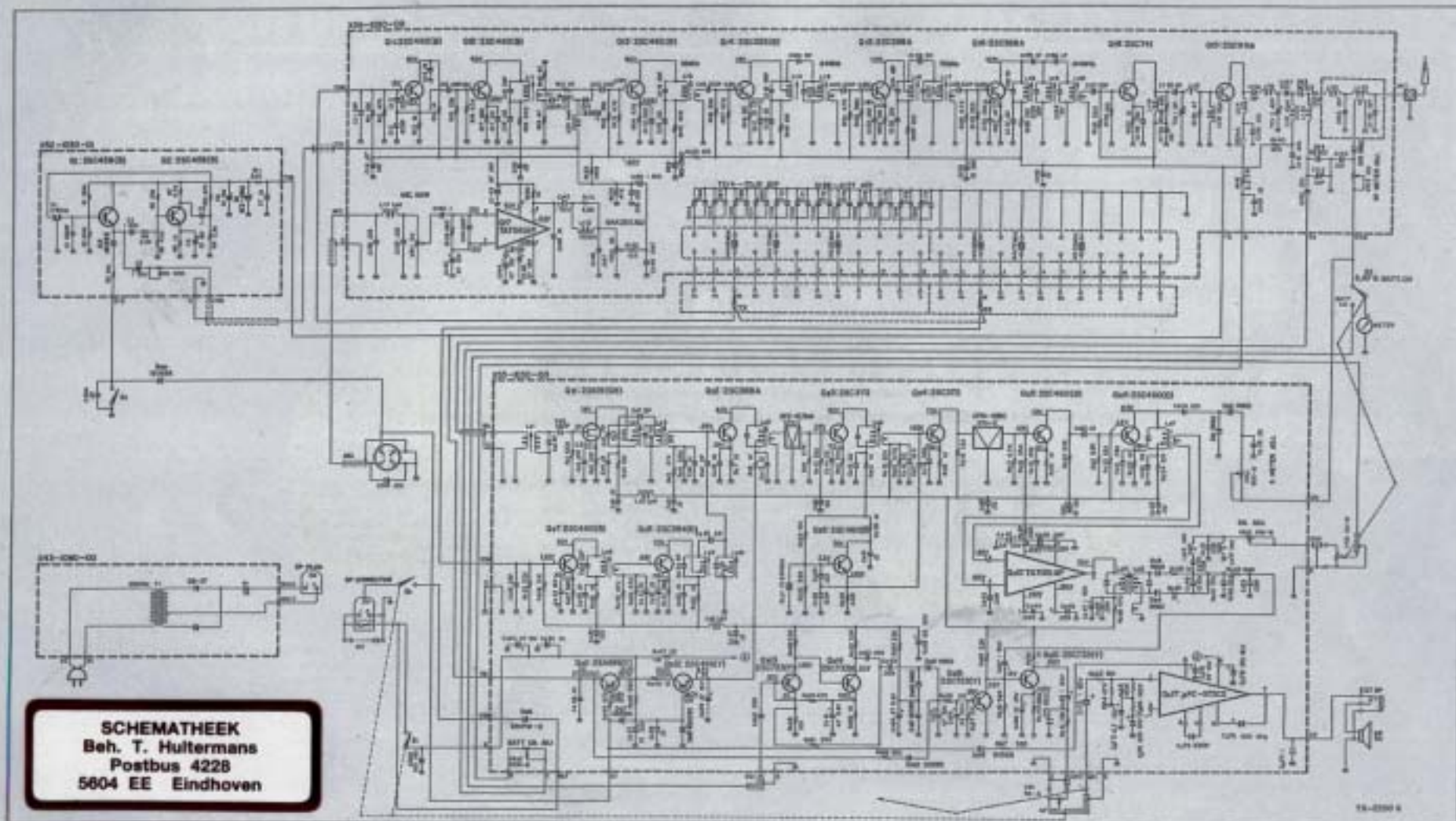

SCHEMATHEEK
Beh. T. Hultermans
Postbus 4228
5604 EE Eindhoven