



BASIC MANUAL

ALL MODE TRANSCEIVER  
**IC-905**



Thank you for choosing this Icom product. This product is designed and built with Icom's state of the art technology and craftsmanship. With proper care, this product should provide you with years of trouble-free operation.

This product combines traditional analog technologies with the Digital Smart Technologies for Amateur Radio (D-STAR), for a balanced package.

## IMPORTANT

**READ ALL INSTRUCTIONS** carefully and completely before using the transceiver.

**SAVE THIS INSTRUCTION MANUAL**— This instruction manual contains basic operating instructions for the IC-905. For advanced operating instructions, see the Advanced manual for details. The Advanced manual is available at the following internet address:  
<https://www.icomjapan.com/support/>

## FEATURES

- **144 ~ 5600 MHz/10 GHz\* coverage**  
 The IC-905 has 144 ~ 5600 MHz/10 GHz\* coverage with all modes.  
 \* Optional CX-10G transverter is required.
- **The separate configuration**  
 The IC-905 consists of the controller and the RF unit that is mounted directly under the antenna.
- **RF Direct Sampling System**  
 The IC-905 employs an RF direct sampling system. RF signals are directly converted to digital data in the ADC, and then processed in the FPGA. This system is a leading technology, marking an epoch in amateur radio.  
 ① 1200 MHz and higher bands use a down conversion IF sampling.
- **Real-Time Spectrum Scope**  
 The spectrum scope is class-leading in resolution, sweep speed, and dynamic range. When you touch the scope screen on the intended signal, the touched area is magnified. The large 4.3 inch color TFT touch LCD offers intuitive operation.
- **D-STAR operation (DV/DD Mode)**  
 The IC-905 has the D-STAR Repeater (DR) function.
- **A 4.3 inch touch panel color display**
- **Multi-function control for easy settings**
- **ATV (Amateur TV) in the analog FM mode**  
 ① You cannot transmit to or receive from the conventional transceivers (IC-1271A/IC-1271E/IC-1275A/IC-1275E) in the ATV mode. Only ATV in the analog AM mode is compatible with them.

## SUPPLIED ACCESSORIES

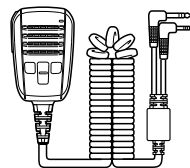

Speaker microphone  
(0.8 m: 2.6 ft)

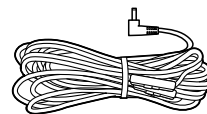

DC power cable  
(1.5 m: 4.9 ft)



Ferrite EMI filter



Spare fuse  
(250 V/8 A)

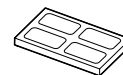

Cushion Sheet



CW key plug  
(3.5 mm: 1/8 inch stereo)



Control cable for connecting  
Controller and RF unit  
(5 m: 16.4 feet)



GPS antenna

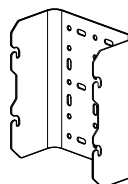

Bracket



Assembled screws for bracket  
(6 × 15 mm)



Pole clamps



U-bolts



Screws and washers  
for attaching to a pole



Accessory connector



Rubber vulcanizing tape

① Some accessories are not supplied, or the shape is different, depending on the transceiver version.



### About weld lines

This product's surfaces may have streaks called "weld lines," that occur during the molding process, and are not cracks or flaws.

---

## EXPLICIT DEFINITIONS

---

WORD	DEFINITION
 <b>DANGER!</b>	Personal death, serious injury or an explosion may occur.
 <b>WARNING!</b>	Personal injury, fire hazard or electric shock may occur.
<b>CAUTION</b>	Equipment damage may occur.
<b>NOTE</b>	Recommended for optimum use. No risk of personal injury, fire or electric shock.

---

## DISPOSAL

---



The crossed-out wheeled-bin symbol on your product, literature, or packaging reminds you that in the European Union, all electrical and electronic products, batteries, and accumulators (rechargeable batteries) must be taken

to designated collection locations at the end of their working life. Do not dispose of these products as unsorted municipal waste.

Dispose of them according to the laws in your area.

---

## ABOUT CE AND DOC

---

 Hereby, Icom Inc. declares that the versions of IC-905 which have the “CE” symbol on the product, comply with the essential requirements of the Radio Equipment Directive, 2014/53/EU, and the restriction of the use of certain hazardous substances in electrical and electronic equipment Directive, 2011/65/EU. The full text of the EU declaration of conformity is available at the following internet address:

<https://www.icomjapan.com/support/>

Icom is not responsible for the destruction, damage to, or performance of any Icom or non-Icom equipment, if the malfunction is because of:

- Force majeure, including, but not limited to, fires, earthquakes, storms, floods, lightning, or other natural disasters, disturbances, riots, war, or radioactive contamination.
- The use of Icom transceivers with any equipment that is not manufactured or approved by Icom.

---

## FCC INFORMATION

---

This equipment has been tested and found to comply with the limits for a Class B digital device, pursuant to part 15 of the FCC Rules.

These limits are designed to provide reasonable protection against harmful interference in a residential installation. This equipment generates, uses and can radiate radio frequency energy and, if not installed and used in accordance with the instructions, may cause harmful interference to radio communications. However, there is no guarantee that interference will not occur in a particular installation. If this equipment does cause harmful interference to radio or television reception, which can be determined by turning the equipment off and on, the user is encouraged to try to correct the interference by one or more of the following measures:

- Reorient or relocate the receiving antenna.
- Increase the separation between the equipment and receiver.
- Connect the equipment into an outlet on a circuit different from that to which the receiver is connected.
- Consult the dealer or an experienced radio/TV technician for help.

**CAUTION:** Changes or modifications to this device, not expressly approved by Icom Inc., could void your authority to operate this device under FCC regulations.

### ◇ FCC SDoC

This device complies with part 15 of the FCC Rules. Operation is subject to the condition that this device does not cause harmful interference.

### Responsible Party

Company Name: Icom America Inc.

Address: 12421 Willows Road NE Kirkland, WA 98034

### U.S. Contact Information

800-USA-ICOM (800-872-4266)

Monday – Friday 7 AM to 5 PM PST

---

## VOICE CODING TECHNOLOGY

The AMBE+2™ voice coding Technology embodied in this product is protected by intellectual property rights including patent rights, copyrights and trade secrets of Digital Voice Systems, Inc. This voice coding Technology is licensed solely for use within this Communications Equipment.

The user of this Technology is explicitly prohibited from attempting to extract, remove, decompile, reverse engineer, or disassemble the Object Code, or in any other way convert the Object Code into a human-readable form. U.S. Patent Nos. #8,595,002, #8,359,197, #8,315,860, #8,200,497, #7,970,606, #6,912,495 B2.

---

## TRADEMARKS

Icom and the Icom logo are registered trademarks of Icom Incorporated (Japan) in Japan, the United States, the United Kingdom, Germany, France, Spain, Russia, Australia, New Zealand, and/or other countries.

Adobe, Acrobat, and Reader are either registered trademarks or trademarks of Adobe Systems Incorporated in the United States and/or other countries.

AMBE+2 is a trademark and property of Digital Voice Systems Inc.

All other products or brands are registered trademarks or trademarks of their respective holders.

---

## ABOUT SPURIOUS SIGNALS

Spurious signals may be received near the following frequencies. These are made in the internal circuit and does not indicate a transceiver malfunction:

- 144.3823 MHz
- 438.5853 MHz
- 1273.0623 MHz
- 1277.9504 MHz
- 1287.0466 MHz
- 1291.9673 MHz
- 1297.6387 MHz
- 5666.2705 MHz
- 5701.6305 MHz
- 430.0783 MHz
- 1261.7196 MHz
- 1276.8433 MHz
- 1287.0387 MHz
- 1287.7261 MHz
- 1295.5182 MHz
- 2402.5185 MHz
- 5687.9985 MHz

This product includes RTOS "RTX" software, and is licensed according to the software license.

This product includes "zlib" open source software, and is licensed according to the open source software license.

This product includes "libpng" open source software, and is licensed according to the open source software license.

This product includes "mbed TLS" open source software, and is licensed according to the open source software license.

Refer to the "About the Licenses" page at the end of the manual in English for information on the open source software being used in this product.

This software is based in part on the work of the Independent JPEG Group, and is licensed according to the open source software license.

---

## IMPORTANT NOTES

---

### ◇ When using the GPS receiver

- The GPS antenna is attached to the RF unit's top panel. Therefore, when the GPS receiver is activated, do not cover the antenna with anything that will block the satellite signals.
- GPS signals cannot pass through metal objects. When using the transceiver inside a vehicle, you may not receive GPS signals. We recommend you use it near a window.
- The Global Positioning System (GPS) is built and operated by the U.S. Department of Defense. The Department is responsible for accuracy and maintenance of the system. Any changes by the Department may affect the accuracy and function of the GPS system.
- The GPS receiver may not work if used in the following locations:
  - Tunnels or high-rise buildings
  - Underground parking lots
  - Under a bridge or viaduct
  - In remote forested areas
  - Under bad weather conditions (rainy or cloudy day)

### ◇ Electromagnetic Interference

When using the transceiver in the 2.4 GHz or 5.6 GHz band, pay attention to the following:

These bands are also used by other devices, such as Wireless LAN products, Bluetooth devices, microwave ovens, RFID systems, and so on.

When using this device near such devices, interference may occur, causing a decrease in communication speed, and an unstable connection. In such cases, use this device away from the other devices, or stop using those devices.

---

## ABOUT THE TOUCH SCREEN

---

### ◇ Touch operation

In the Advanced manual and the Basic manual, the touch operation is described as shown below, with the beep tone ON.



#### **Touch**

If the display is touched briefly, one short beep sounds.



#### **Touch for 1 second**

If the display is touched for 1 second, one short and one long beep sound.

### ◇ Touch screen precautions

- The touch screen may not properly work when the LCD protection film or sheet is attached.
- Touching the screen with your finger nails, sharp topped object and so on, or touching the screen hard may damage it.
- Tablet PC operations such as flick, pinch in, and pinch out cannot be performed on this touch screen.

### ◇ Touch screen maintenance

- If the touch screen becomes dusty or dirty, wipe it clean with a soft, dry cloth.
- When you wipe the touch screen, be careful not to push it too hard or scratch it with your finger nails. Otherwise you may damage the screen.

---

## ABOUT THE MANUALS

---

You can use the following manuals to understand and operate this transceiver. (As of February 2023)

**TIP:** You can download each manual and guide from the Icom website.  
<https://www.icomjapan.com/support/>  
Enter "IC-905" into the Search box in the site.

- **Basic manual (This manual)**  
Instructions for basic operations.
- **Connection guide (Leaflet)**  
Instructions for connecting the controller and RF unit.
- **Advanced manual (PDF type)**  
Instructions for advanced operations in English.
- **CI-V Reference guide (PDF type)**  
Describes the control commands used in remote control operation (serial communication with CI-V) in English.
- **About the Share Pictures function (PDF type)**  
Describes how to use the Share Pictures function in English.

### For Reference

- **HAM Radio Terms (PDF type)**  
A glossary of HAM radio terms in English.

To read the manuals or Guide, Adobe® Acrobat® Reader® is required. If you have not installed it, please download the Adobe® Acrobat® Reader® and install it to your PC. You can download it from Adobe Systems Incorporated's website.

# ABOUT THE INSTRUCTIONS

The Advanced and Basic manuals are described in the following manner.

**“ ” (Quotation marks):**

Used to indicate icons, setting items, and screen titles displayed on the screen. The screen titles are also written in uppercase letters. (Example: FUNCTION screen)

**[ ] (brackets):**

Used to indicate keys.

**Routes to the Set modes and Setting screens**

Routes to the Set mode, Setting screens and the setting items are described in the following manner.

**[MENU]** » **SET > Time Set > Date/Time > Date**

**Instruction example:**

◇ **Setting the date**

1. Open the “Date” screen.  
**[MENU]** » **SET > Time Set > Date/Time > Date**
2. Touch [+] or [-] to set the date.

**Detailed instruction:**

1. Push **[MENU]**.

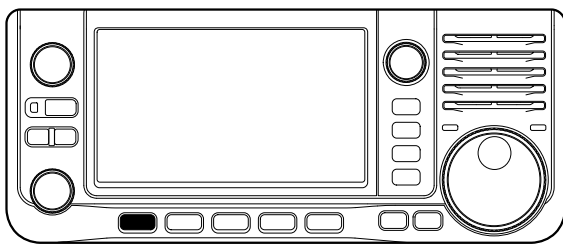

2. Touch **[SET]**.



3. Touch **[▲]** or **[▼]** to scroll through the items.  
 ① You can also rotate **[MULTI]** to scroll through the items.

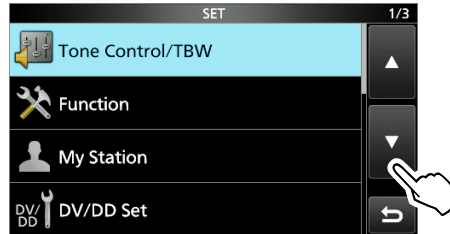

4. Touch “Time Set.”

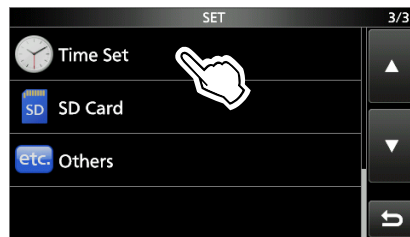

5. Touch “Date/Time.”

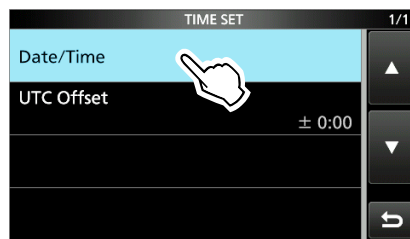

6. Touch “Date.”

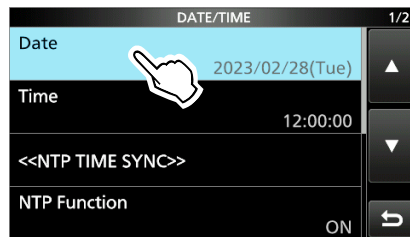

- Opens the “Date” screen.

# KEYBOARD ENTERING AND EDITING

## Keyboard types:

You can select the Full Keyboard or Tenkey pad in "Keyboard Type" on the FUNCTION screen. (p. 8-6)

**MENU** » **SET > Function > Keyboard Type**

① You can also temporarily switch in the QUICK MENU screen by pushing **QUICK**.

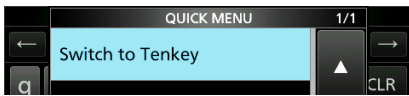
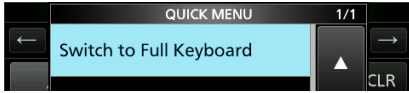

① You can select the full keyboard layout in "Full Keyboard Layout" on the FUNCTION screen. (p. 8-6)

**MENU** » **SET > Function > Full Keyboard Layout**

## Entering and editing:

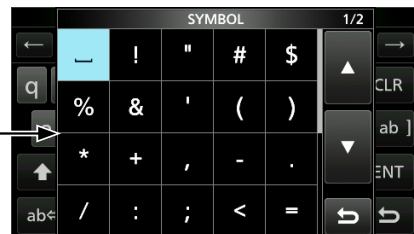
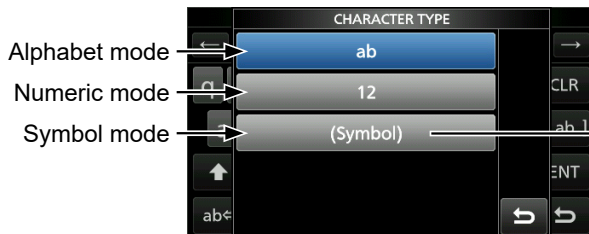
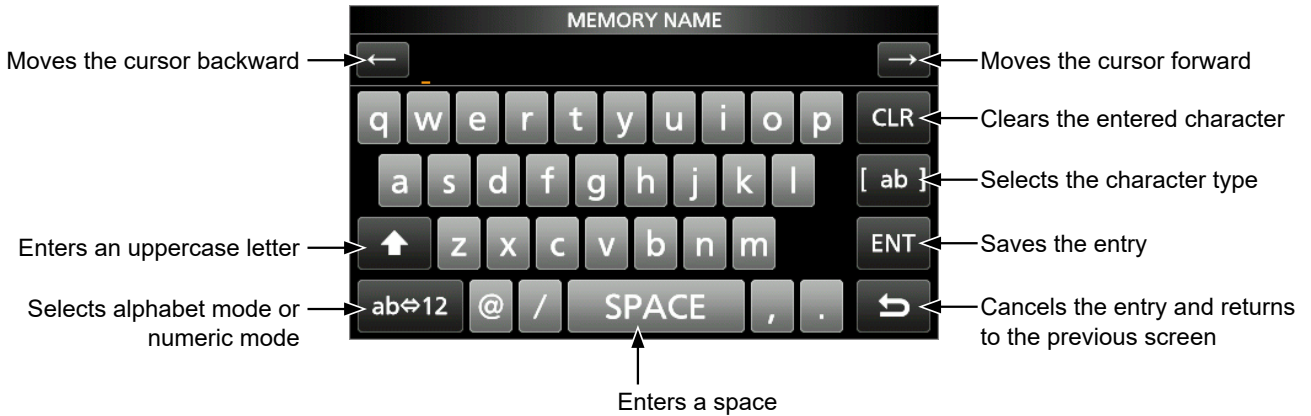



## USABLE CHARACTERS

You can enter and edit the items in the following table.

Menu	Category	Item	Selectable characters	Maximum characters
SET	My Station	My Call Sign	A to Z, 0 to 9, (space), /	8 + 4
		TX Message	[AB] [ab] [12] [!"#]	20
	Network Set	Network Name	A to Z, 0 to 9, ! " # \$ % & ( ) + , - . ; = @ [ ] ^	15
		Network User 1/2 ID	[AB] [ab] [12] [!"#]	16
		Network User 1/2 Password	• Illegal characters: \ (space)	16* <sup>1</sup>
		Network Radio Name		16
	Time Set	NTP Server Address	A to Z, a to z, 0 to 9, - .	64
	SD Card	Save Setting	[AB] [ab] [12] [!"#]	23
Export		• Illegal characters: / : ; * < > \		
MEMORY		GROUP NAME, MEMORY NAME	[AB] [ab] [12] [!"#]	16
SCAN	Program Scan Edge	NAME	[AB] [ab] [12] [!"#]	16
KEYER		Keyer Memory	A to Z, 0 to 9, (space), / ? ^ . , @ • " *" (asterisk) has its own unique use.	70
DECODE		RTTY Memory	A to Z, 0 to 9, (space), ! \$ & ? " ' - / . , ; ( ) _ \	70
VOICE		VOICE TX RECORD	[AB] [ab] [12] [!"#]	16
CS		UR, R1, R2	A to Z, 0 to 9, (space), /	8
DV/DD MEMORY	Your Call Sign	NAME	[AB] [ab] [12] [!"#]	16
		CALL SIGN	A to Z, 0 to 9, (space), /	8
	Repeater List	GROUP NAME, NAME	[AB] [ab] [12] [!"#]	16
		SUB NAME	[AB] [ab] [12] [!"#]	8
		CALL SIGN, GW CALL SIGN	A to Z, 0 to 9, (space), /	8
DV GW	Internal Gateway Settings	Gateway Repeater (Server IP/Domain)	A to Z, a to z, 0 to 9, - .	64
		Terminal/AP Call sign, Allowed Call Sign List	A to Z, 0 to 9, (space)	8
GPS	GPS TX Mode	Unproto Address	[AB] [ab] [12] [!"#]	56* <sup>2</sup>
		Object Name, Item Name	[AB] [ab] [12] [!"#]	9
		Comment	[AB] [ab] [12] [!"#]	43* <sup>3</sup>
		GPS Message	[AB] [ab] [12] [!"#]	20
	GPS Memory	GROUP NAME, NAME	[AB] [ab] [12] [!"#]	16
DTMF	DTMF MEMORY		0 to 9, A B C D * #	24
	SEND	Direct Input	0 to 9, A B C D * #	24
PRESET		Preset Name	[AB] [ab] [12] [!"#]	16
DR	TO SELECT	Direct input (UR)/(RPT)	A to Z, 0 to 9, (space), /	8

[AB]: A to Z, (space)

[ab]: a to z, (space)

[12]: 0 to 9, (space)

[!"#]: ! " # \$ % & ' ( ) \* + , - . / : ; < = > ? @ [ \ ] ^ \_ ` { | } ~  
(space)

\*<sup>1</sup> Minimum of 8 characters

\*<sup>2</sup> Normally 12 characters

\*<sup>3</sup> The maximum number of characters you can enter depends on the data extension and altitude settings.

# TABLE OF CONTENTS

IMPORTANT.....	i	Selecting the operating band.....	3-2
FEATURES.....	i	Selecting the operating mode.....	3-2
SUPPLIED ACCESSORIES.....	i	Setting the frequency.....	3-3
EXPLICIT DEFINITIONS.....	ii	◇ Using the Main Dial.....	3-3
DISPOSAL.....	ii	◇ About the Tuning Step function.....	3-3
ABOUT CE AND DOC.....	ii	◇ Changing the Tuning Step.....	3-3
FCC INFORMATION.....	ii	◇ About the 1 MHz Step Tuning function.....	3-3
◇ FCC SDoC.....	ii	◇ About the 1 Hz step Fine Tuning function.....	3-3
VOICE CODING TECHNOLOGY.....	iii	◇ About the 1/4 Tuning function.....	3-4
TRADEMARKS.....	iii	◇ About the Auto Tuning Step function.....	3-4
ABOUT SPURIOUS SIGNALS.....	iii	◇ Directly entering a frequency.....	3-4
◇ When using the GPS receiver.....	iv	◇ Band Edge Beep.....	3-6
◇ Electromagnetic Interference.....	iv	◇ Entering a Band Edge.....	3-6
ABOUT THE TOUCH SCREEN.....	v	Dial Lock function.....	3-8
◇ Touch operation.....	v	RF gain and SQL level.....	3-9
◇ Touch screen precautions.....	v	Adjusting the microphone gain.....	3-9
◇ Touch screen maintenance.....	v	Meter display.....	3-10
ABOUT THE MANUALS.....	v	◇ Meter display selection.....	3-10
ABOUT THE INSTRUCTIONS.....	vi	◇ Multi-function meter.....	3-10
◇ Setting the date.....	vi	Adjusting the transmit output power.....	3-11
KEYBOARD ENTERING AND EDITING.....	vii	Transmit Power Limit function.....	3-11
USABLE CHARACTERS.....	viii	<b>4 RECEIVING AND TRANSMITTING.....</b>	<b>4-1</b>
PRECAUTIONS.....	xi	Preamplifiers.....	4-1
<b>1 PANEL DESCRIPTION.....</b>	<b>1-1</b>	Attenuator.....	4-1
Front panel (Controller).....	1-1	RIT function.....	4-2
Bottom panel (Controller).....	1-2	◇ RIT monitor function.....	4-2
Side panels (Controller).....	1-3	Monitor function.....	4-2
Top panel/Bottom panel (RF unit).....	1-4	AFC function.....	4-3
Speaker microphone.....	1-4	AGC function control.....	4-4
Touch screen display.....	1-5	◇ Selecting the AGC time constant preset value...	4-4
◇ FUNCTION screen.....	1-7	◇ Setting the AGC time constant.....	4-4
◇ MENU screen.....	1-7	Using the Digital Twin PBT.....	4-5
◇ QUICK MENU.....	1-7	Selecting the IF filter.....	4-6
◇ Multi-function menus.....	1-8	Selecting the IF filter shape.....	4-6
Multi-function dial.....	1-8	Notch Filter.....	4-7
<b>2 INSTALLATION AND CONNECTIONS.....</b>	<b>2-1</b>	◇ Selecting the Notch filter type.....	4-7
Selecting a location.....	2-1	◇ Setting the Manual Notch filter.....	4-7
Heat dissipation.....	2-1	Noise Blanker.....	4-8
Attaching the cushions.....	2-1	◇ Adjusting the NB level and time.....	4-8
Connecting a microphone.....	2-1	Noise Reduction.....	4-9
[DC 13.8 V].....	2-1	◇ Adjusting the Noise Reduction level.....	4-9
Connecting an external DC power supply.....	2-2	Setting the transmit filter width.....	4-9
<b>3 BASIC OPERATION.....</b>	<b>3-1</b>	Setting the Speech Compressor.....	4-10
When first applying power.....	3-1	◇ Setting before using the	
Turning power ON or OFF.....	3-1	Speech Compressor function.....	4-10
Adjusting the volume level.....	3-1	◇ Using the Speech Compressor function.....	4-10
Selecting the mode.....	3-1	Split frequency operation.....	4-11
Using the VFO mode.....	3-1	◇ Using the Quick Split function.....	4-11
◇ Selecting VFO A or VFO B.....	3-1	◇ Using the receive and transmit frequencies	
◇ Equalizing VFO A and VFO B.....	3-1	set to VFO A and VFO B.....	4-11

Split Lock function .....	4-12	<b>10 MAINTENANCE .....</b>	<b>10-1</b>
Operating CW.....	4-12	Cleaning .....	10-1
◇ Setting the CW pitch control.....	4-12	Replacing fuse.....	10-1
◇ Setting the key speed.....	4-12	Resetting .....	10-1
◇ Using the Break-in function .....	4-13	◇ Partial reset .....	10-2
◇ Monitoring the CW side tone .....	4-13	◇ All reset .....	10-2
◇ About the electronic Keyer function.....	4-14	Troubleshooting.....	10-3
Auto Tuning function.....	4-14	<b>11 SPECIFICATIONS .....</b>	<b>11-1</b>
<b>5 SCOPE OPERATION.....</b>	<b>5-1</b>	◇ General.....	11-1
Spectrum scope screen.....	5-1	◇ Receiver .....	11-2
◇ Using the Spectrum Scope.....	5-1	◇ Transmitter .....	11-3
◇ Center mode.....	5-2	<b>12 OPTIONS .....</b>	<b>12-1</b>
◇ Fixed mode.....	5-2	Options .....	12-1
◇ Scroll mode .....	5-2	<b>13 CONNECTOR INFORMATION .....</b>	<b>13-1</b>
◇ Marker .....	5-2	Controller.....	13-1
◇ Touch screen operation .....	5-3	◇ [ELEC-KEY].....	13-1
◇ Mini scope screen .....	5-3	◇ [EXT-SP].....	13-1
Audio scope screen.....	5-3	◇ [MIC-SP].....	13-1
<b>6 SD CARD .....</b>	<b>6-1</b>	◇ [MIC].....	13-1
About the SD cards .....	6-1	◇ [AV-IN] .....	13-2
Saving data .....	6-1	◇ [AV-OUT] .....	13-2
Inserting.....	6-1	◇ [SEND] .....	13-2
Formatting .....	6-1	◇ [LAN] .....	13-3
Saving the setting data.....	6-2	◇ [RF UNIT] .....	13-3
Unmounting .....	6-2	◇ [USB].....	13-3
<b>7 GPS OPERATION.....</b>	<b>7-1</b>	RF unit.....	13-4
Confirming the GPS signal receiving.....	7-1	◇ [ACC].....	13-4
Checking your location .....	7-1	◇ [REF OUT 10 MHz/-10 dBm].....	13-5
<b>8 SET MODE.....</b>	<b>8-1</b>	◇ [GPS ANT].....	13-5
Set mode description.....	8-1	◇ [144/430/1200 MHz ANT].....	13-5
Tone Control/TBW .....	8-2	◇ [2400 MHz ANT].....	13-5
Function.....	8-2	◇ [5600 MHz ANT].....	13-5
My Station .....	8-6	INSTALLATION NOTES .....	I
DV/DD Set.....	8-9	INDEX.....	II
QSO/RX Log .....	8-11	ABOUT THE LICENSES .....	III
Connectors .....	8-14		
Network .....	8-16		
Display.....	8-18		
Time Set .....	8-21		
SD Card.....	8-21		
Others.....	8-22		
<b>9 CLOCK.....</b>	<b>9-1</b>		
Setting the date and time .....	9-1		
◇ Setting the date .....	9-1		
◇ Setting the current time .....	9-1		
◇ Setting the UTC offset.....	9-1		

---

## PRECAUTIONS

---

⚠ **DANGER HIGH RF VOLTAGE! NEVER** touch an antenna, an antenna connector, or a ground terminal while transmitting. This could cause an electrical shock or burn.

⚠ **DANGER! NEVER** operate the transceiver near unshielded electrical blasting caps or in an explosive atmosphere. This could cause an explosion and death.

⚠ **WARNING RF EXPOSURE!** This transceiver emits Radio Frequency (RF) energy. Extreme caution should be observed when operating this transceiver. If you have any questions regarding RF exposure and safety standards please refer to the Federal Communications Commission Office of Engineering and Technology's report on Evaluating Compliance with FCC Guidelines for Human Radio Frequency Electromagnetic Fields (OET Bulletin 65).

⚠ **WARNING! NEVER** operate the transceiver with earphone, a headset, or other audio accessories at high volume levels. If you experience a ringing in your ears, reduce the volume or discontinue use.

⚠ **WARNING! NEVER** apply AC power to the [DC 13.8 V] jack on the controller side panel. This could cause a fire or damage the transceiver.

⚠ **WARNING! NEVER** apply more than 16 V DC to the [DC 13.8 V] jack on the controller side panel. This could cause a fire or damage the transceiver.

⚠ **WARNING! NEVER** reverse the DC power cable polarity. This could cause a fire or damage the transceiver.

⚠ **WARNING! NEVER** remove the fuse holder on the DC power cable. Excessive current caused by a short could cause a fire or damage the transceiver.

⚠ **WARNING! NEVER** let metal, wire or other objects contact the inside of the transceiver, or make incorrect contact with connectors on the side panel. This could cause an electric shock or damage the transceiver.

⚠ **WARNING! NEVER** operate or touch the transceiver with wet hands. This could cause an electric shock or damage to the transceiver.

⚠ **WARNING! NEVER** operate the equipment if you notice an abnormal odor, sound or smoke. Immediately turn OFF the power and/or remove the DC power cable. Contact your Icom dealer or distributor for advice.

⚠ **WARNING! NEVER** put the transceiver on an unstable place where the transceiver may suddenly move or fall. This could cause an injury or damage the transceiver.

⚠ **WARNING! NEVER** operate the transceiver during a lightning storm. It may result in an electric shock, cause a fire or damage the transceiver. Always disconnect the power source and antenna before a storm.

**CAUTION: DO NOT** expose the controller to rain, snow or any liquids. They could damage the controller.

**CAUTION: DO NOT** operate the transceiver unless the antenna and cables are securely attached to the transceiver, and that the antenna and cables are dry before attachment. Exposing the inside of the transceiver to dust or water will result in serious damage to the transceiver.

**CAUTION: DO NOT** operate the transceiver while driving a vehicle. Safe driving requires your full attention—anything less may result in an accident.

**CAUTION: DO NOT** change the internal settings of the transceiver. This could reduce transceiver performance and/or damage to the transceiver. The transceiver warranty does not cover any problems caused by unauthorized internal adjustments.

**CAUTION: DO NOT** install or place the transceiver in a place without adequate ventilation. Heat dissipation may be reduced and damage the transceiver.

**CAUTION: DO NOT** use harsh solvents such as Benzine or alcohol when cleaning. This could damage the transceiver surfaces. If the surface becomes dusty or dirty, wipe it clean with a soft, dry cloth.

**CAUTION: DO NOT** leave the transceiver in areas with out of the specified temperature range for the controller (0°C ~ 50°C, 32°F ~ 122°F) and the RF unit (-10°C ~ +55°C, 14°F ~ 131°F) for mobile operations.

**CAUTION: DO NOT** place the transceiver in excessively dusty environments. This could damage the transceiver.

**CAUTION: DO NOT** place the transceiver against walls or putting anything around the transceiver. This may overheat the transceiver.

**CAUTION: DO NOT** set the transceiver's RF output power to more than a connected linear amplifier's maximum input level. Otherwise, the linear amplifier will be damaged.

**CAUTION: DO NOT** use non-Icom microphones. Other microphones have different pin assignments, and may damage the transceiver.

---

---

---

**DO NOT** push PTT unless you actually intend to transmit.

**NEVER** leave the transceiver in an insecure place to avoid use by unauthorized persons.

Turn OFF the transceiver's power and disconnect the DC power cable when you will not use the transceiver for long period of time.

The LCD display may have cosmetic imperfections that appear as small dark or light spots. This is not a malfunction or defect, but a normal characteristic of LCD displays.



**CAUTION:** Hot surfaces. **DO NOT** touch the transceiver's surface after continuously transmitting for long periods of time. The transceiver's chassis radiates heat, and it will become hot to protect the power amplifier unit from overheating. Touching it may cause a burn.

## Front panel (Controller)

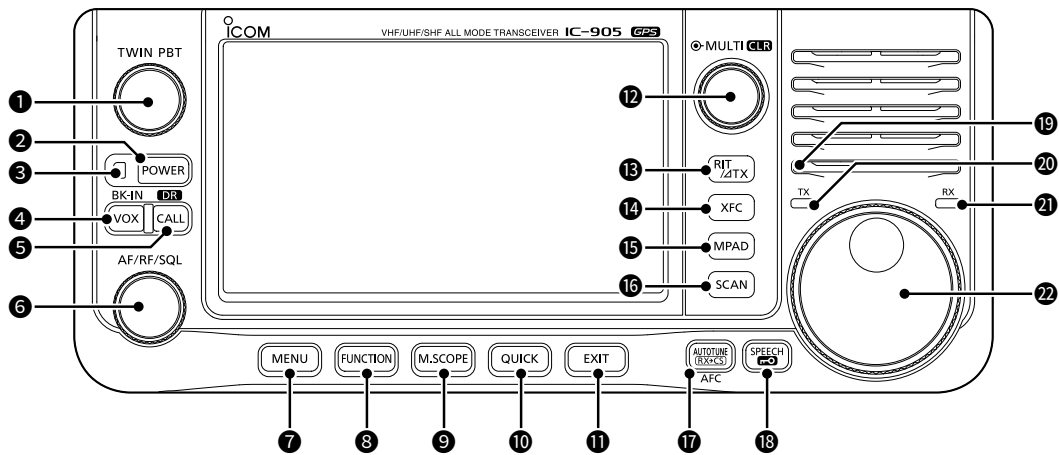
**1 PASSBAND TUNING CONTROL (TWIN PBT)**

(p. 4-5)

- Push to toggle between “PBT1” and “PBT2,” then rotate to adjust the shift value.
- Hold down for 1 second to clear the PBT settings.

**2 POWER KEY (POWER)** (p. 3-1)

- Push to turn ON the transceiver.
- Hold down for 1 second to turn OFF the transceiver.

**3 POWER INDICATOR**

- Lights green while the transceiver is ON.
- Blinks green while the transceiver is in the Screen Saver mode.
- Lights orange while the display is OFF by pushing (POWER).
- Blinks orange while the transceiver is in the Standby mode.

**4 VOX/BREAK-IN KEY (VOX) / (BK-IN)**

Push to turn the VOX function and the Break-in function in the CW mode (p. 4-13) ON or OFF.

**5 CALL/DR FUNCTION KEY (CALL) / (DR)**

- Push to toggle between the Call channel mode and the VFO/Memory modes. (p. 3-1)
- Hold down for 1 second to turn the DR function ON or OFF.

**6 VOLUME/RF GAIN/SQUELCH CONTROL (AF/RF/SQL)**

- Rotate to adjust the audio output level. (p. 3-1)
- Push to display the setting menu, touch the menu item, and then rotate to adjust the RF gain (sensitivity) or squelch threshold levels. (p. 3-9)

**7 MENU KEY (MENU)** (p. 1-7)

Push to open the MENU screen.

**8 FUNCTION KEY (FUNCTION)** (p. 1-7)

Push to open the FUNCTION screen.

**9 MINI SCOPE KEY (M.SCOPE)** (p. 5-3)

- Push to display the Mini scope screen.
- Hold down for 1 second to display the Spectrum scope screen.

**10 QUICK KEY (QUICK)** (p. 1-7)

Push to open the QUICK MENU screen.

**11 EXIT KEY (EXIT)**

Push to exit a setting screen or return to the previous screen.

**12 MULTI-FUNCTION CONTROL (MULTI) / (CLR)**

- Push to open the Multi-function menu for various adjustments. (p. 1-8)
- Rotate to adjust the value that is assigned to (MULTI). (p. 1-8)

**13 RIT/ $\Delta$ TX KEY (RIT/ $\Delta$ TX)**

- Push to turn the Receiver Incremental Tuning (RIT) function (p. 4-2) or the  $\Delta$ TX function ON or OFF.
- Hold down to toggle between the RIT function and the  $\Delta$ TX function.

**14 TRANSMIT FREQUENCY CHECK KEY (XFC)**

- In the Split or Duplex mode, holding the key down enables you to monitor the transmit frequency.
- In the Simplex mode, holding the key down temporarily opens the squelch and cancels the noise reduction function.

① In the DV mode, holding the key down enables you to monitor signals in the FM or DV mode, depending on the Digital Monitor setting.

Front panel (Controller)

15 MEMO PAD KEY **MPAD**

- Push to sequentially call up the contents in the Memo Pads.
- Hold down for 1 second to save the displayed contents into the Memo Pad.

16 SCAN KEY **SCAN**

- Push to display the SCAN SELECT screen.
- Hold down for 1 second to start the previously selected scan.

17 AUTO TUNE/RX CALL SIGN CAPTURE/AFC KEY



- In the CW mode, pushing the key automatically tunes the operating frequency to a close-by CW signal. (p. 4-14)
- In the FM or DV mode, push to turn the Auto Frequency Control function ON or OFF.
- In the DV and DD mode, hold down for 1 second to display the RX History list.

18 SPEECH/LOCK KEY **SPEECH**

- Push to announce the operating frequency or mode.
- Hold down for 1 second to electronically lock **MAIN DIAL**. (p. 3-8)

19 AMBIENT LIGHT SENSOR

Used to automatically adjust the display's backlight brightness.

① **DO NOT** cover the sensor.

20 TX INDICATOR

Lights red while transmitting.

21 RX INDICATOR

Lights green while receiving.

22 MAIN DIAL **MAIN DIAL**

Rotate to change the operating frequency.

Bottom panel (Controller)

You can attach a third party mounting base using screw holes\* on the bottom panel.

\* AMPS hole pattern

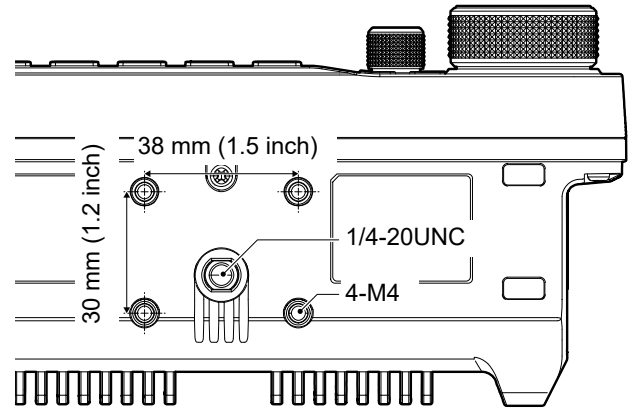

## Side panels (Controller)

Right side panel

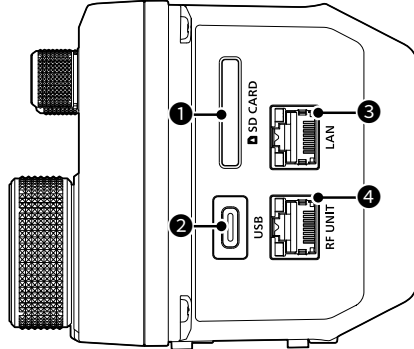

- 1 SD CARD SLOT [SD CARD] (p. 6-1)**  
Insert an SD card (user supplied).
- 2 USB PORT (TYPE-C) [USB] (p. 13-3)**  
Connects to a PC or other USB device.
- 3 ETHERNET CONNECTOR [LAN] (p. 13-3)**  
Connects to a PC network through a LAN.
- 4 RF UNIT CONNECTOR [RF UNIT] (p. 13-3)**  
Connects to the RF unit with a supplied cable.
- 5 AV-INPUT JACK [AV-IN] (p. 13-2)**  
Connects to an external device, such as a camera, to input audio and video.
- 6 AV-OUTPUT JACK [AV-OUT] (p. 13-2)**  
Connects to an external device, such as a monitor, for displaying the received audio and video.
- 7 SEND JACK [SEND] (p. 13-2)**  
Connect to control transmit with non-Icom external units.

Left side panel

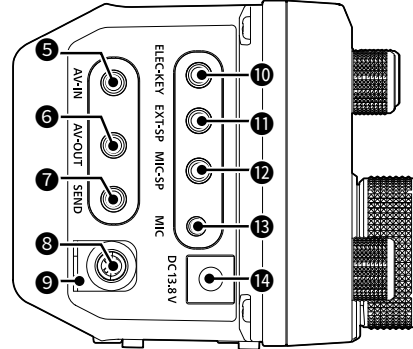

- 8 GROUND TERMINAL [GND]**  
Connect to ground to prevent electrical shocks, TVI, BCI, and other problems.  
① See the Connection guide for details.
- 9 MICROPHONE PLATE (p. 2-1)**  
Attach the microphone's split ring to secure the cable.
- 10 KEY JACK [ELEC-KEY] (p. 13-1)**  
Connects to a straight key, paddle, an external electronic keyer, or an external keypad with a 3.5 mm (1/8 inch) stereo plug.
- 11 EXTERNAL SPEAKER JACK [EXT-SP] (p. 13-1)**  
Connect a 4~8 Ω external speaker with a 3.5 mm (1/8 inch) stereo plug.
- 12 MICROPHONE'S SPEAKER JACK [MIC-SP] (p. 13-1)**  
Connect a supplied speaker microphone's speaker plug. (3.5 mm (1/8 inch))
- 13 MICROPHONE JACK [MIC] (p. 13-1)**  
Connect a supplied speaker microphone's microphone plug. (2.5 mm)
- 14 DC POWER JACK [DC 13.8 V] (p. 2-1)**  
Accepts 13.8 V DC through the supplied DC power cable.

**NOTE:** Confirm that the transceiver is OFF before connecting or disconnecting optional equipment.



**Top panel/Bottom panel (RF unit)**

**Top panel**

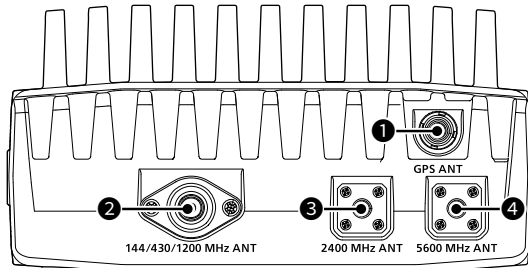

**Bottom panel**

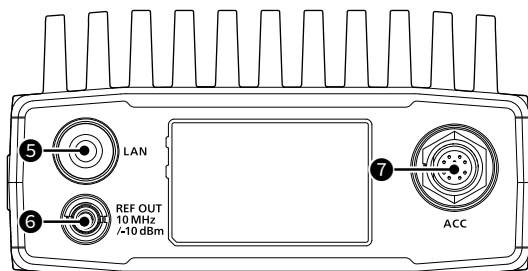

- 1 GPS (GNSS) ANTENNA CONNECTOR**  
[GPS ANT] (p. 13-5)  
Attach a supplied GPS antenna.
- 2 140/430/1200 MHz ANTENNA CONNECTOR**  
[144/430/1200 MHz ANT] (p. 13-5)  
Connect a 50 Ω Type N coax connector for the 144, 430, and 1200 MHz band.
- 3 2400 MHz ANTENNA CONNECTOR**  
[2400 MHz ANT] (p. 13-5)  
Connect a 50 Ω Type SMA coax connector for the 2400 MHz band.
- 4 5600 MHz ANTENNA CONNECTOR**  
[5600 MHz ANT] (p. 13-5)  
Connect a 50 Ω Type SMA coax connector for the 5600 MHz band.
- 5 CONNECTION CABLE to the CONTROLLER**  
Connect to the controller with a supplied cable.
- 6 REFERENCE SIGNAL OUTPUT**  
[REF OUT 10MHz/-10dBm] (p. 13-5)  
Output a 10 MHz reference signal through the BNC connector.
- 7 ACC SOCKET [ACC] (p. 13-4)**  
Connects to devices to control an external unit or to control the transceiver.

**Speaker microphone**

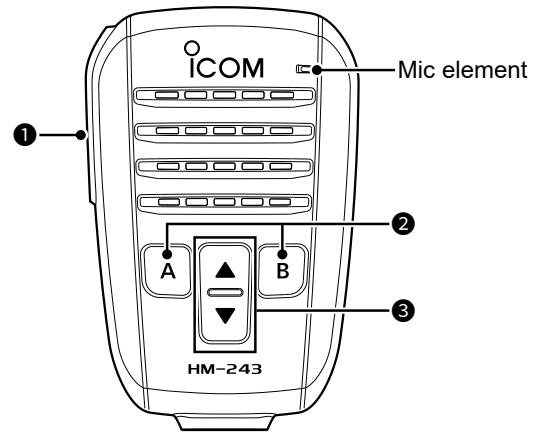

**1 [PTT] SWITCH**

Hold down to transmit, release to receive.

**NOTE:** To maximize the readability of your signal, hold the microphone 5 to 10 cm (2 to 4 inches) from your mouth, and then speak at your normal voice level.

**2 [A] KEY**

Push to activate the assigned function of the [A] key. (Default: Home CH)

**[B] KEY**

Push to activate the assigned function of the [B] key. (Default: VFO/MEMO)

**3 [▲]/[▼] (UP/DOWN) KEYS**

- Push to change the operating frequency or Memory channel.
- Hold down to continuously change the frequency or Memory channel.

**TIP:** You can change the assigned function of the [▲], [▼], [A], and [B] keys in the following item.

**MENU** » SET > Function > **Remote MIC Key**

## Touch screen display

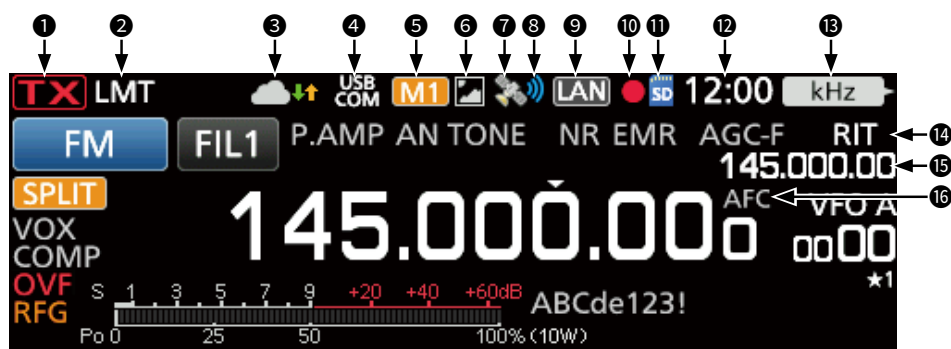

### 1 TX STATUS INDICATOR

Displays the transmit status.

- **TX** is displayed while transmitting.
- **TX** (with a dotted line) is displayed when the selected frequency is outside of the band edge frequency range. (p. 3-6)
- Displayed in orange when the transceiver is in the Terminal mode.
- **TX** (Grayed out) is displayed when transmission is inhibited.
- In the DD mode, **TX Inh** is displayed when “TX INHIBIT” is set to ON.

### 2 LMT ICON **LMT**

Displayed if the power amplifier temperature becomes extremely high, and the Protection function is activated after transmitting continuously for a long period of time.

### 3 INTERNAL GATEWAY

Displays the communication status while using the Internal Gateway function.

### 4 USB CONNECTION INDICATOR

Displayed when an external USB device is connected through a USB cable.

### 5 M1~M8/T1~T8 ICONS

- “M1” ~ “M8” is displayed when “External Keypad” on the CONNECTORS screen is set to “ON,” and you are using the Memory Keyer function.
- “T1” ~ “T8” is displayed when using the Voice TX memory.

### 6 PICTURE SHARE ICON

Displayed when the Share Pictures function is ON.

### 7 GPS ICON (p. 7-1)

Displays the status of the GPS receiver. Touch the icon to display the GPS INFORMATION screen.

### 8 GPS ALARM ICON

Displayed when the GPS Alarm function is ON.

### 9 NETWORK CONTROL ICON

Displayed while accessing the transceiver using the optional RS-BA1 (compatible in the near future), for Remote control operation.

### 10 VOICE RECORDER ICONS

Displayed while recording or pausing using the Voice recorder.

### 11 SD CARD ICON (p. 6-1)

Displayed when an SD card is inserted, and blinks while accessing the card.

### 12 CLOCK READOUT (p. 9-1)

Displays the current local time. Touch the readout to display both the current local time and UTC time.

### 13 FUNCTION INDICATOR FOR MULTI-FUNCTION CONTROL (p. 1-8)

Displays the function that is assigned to .

### 14 RIT/ΔTX ICON

Displayed when the Receive Increment Tuning (RIT) (p. 4-2) or ΔTX function is ON.

### 15 RIT/ΔTX/SPLIT/DUPLEX FREQUENCY READOUT

- Displays the shift offset frequency for the RIT or ΔTX functions.
- Displays the shift frequency for the Duplex function or the split frequency.

### 16 AFC/ ¼ ICON (pp. 4-3, 3-4)

Displayed while the Auto Frequency Control (AFC) function or the 1/4 Tuning function is ON.

Touch screen display

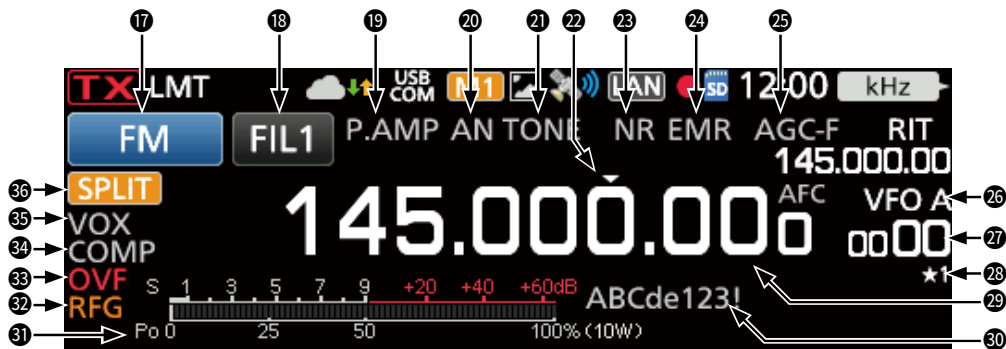

- 17 MODE INDICATOR** FM (p. 3-2)  
Displays the selected operating mode.
- 18 IF FILTER INDICATOR** FIL1 (p. 4-6)  
Displays the selected IF filter number.  
① A dot “.” is displayed on the IF Filter Indicator when you change the IF passband width.
- 19 PREAMPLIFIER/ATTENUATOR ICONS** (p. 4-1)  
Displayed when one of the Preamplifiers (P.AMP) or the Attenuator (ATT) is ON.
- 20 NOTCH INDICATOR** (p. 4-7)  
Displayed when the Auto Notch (AN) or Manual Notch (MN) function is ON.
- 21 NOISE BLANKER/TONE/DIGITAL SQUELCH ICONS** (p. 4-8)  
Displayed when the Noise Blanker (NB), tone, or digital squelch functions is ON.
- 22 QUICK TUNING ICON** (p. 3-3)  
Displayed when the Quick Tuning Step function is ON.  
① Displayed above the 1 MHz digit when the 1 MHz Step Tuning function is ON.
- 23 NOISE REDUCTION/AUTO TUNE ICONS** (pp. 4-9, 4-14)  
Displayed when the Noise Reduction (NR) or Auto Tuning function is ON.
- 24 EMR/BK/AUTO REPLY/PACKET LOSS ICONS**  
Displayed when the Enhanced Monitor Request (EMR), Break-in (BK), Automatic Reply (A/R) function is ON, or “L” is displayed when packet loss has occurred.
- 25 AGC ICON** (p. 4-4)  
Displayed while the Auto Gain Control (AGC) is ON.
- 26 VFO/MEMORY ICONS** (p. 3-1)  
Displays “VFO A” or “VFO B” when the VFO mode is selected, and displays “MEMO” when the Memory mode is selected.
- 27 MEMORY CHANNEL READOUT**  
Displays the selected memory channel number.
- 28 SELECT MEMORY CHANNEL ICON**  
Indicates that the displayed memory channel is assigned as a Select Memory channel (★1~★3).
- 29 FREQUENCY READOUT**  
Displays the operating frequency.
- 30 MEMORY NAME**  
Displays the Memory name, if entered.
- 31 MULTI-FUNCTION METER** (p. 3-10)  
Displays various values and levels, depending on the function that you selected.
- 32 RF GAIN ICON** (p. 3-9)  
Displayed when the RF gain is reduced.
- 33 OVF ICON** (p. 3-9)  
Displayed when an excessively strong signal is received.
- 34 SPEECH COMPRESSOR ICON** (p. 4-10)  
Displayed when the Speech Compressor function is ON.
- 35 BK-IN/F-BKIN/VOX INDICATORS** (p. 4-13)  
Displayed when the Semi Break-in (BK-IN), Full Break-in (F-BKIN), or VOX function is ON.
- 36 SPLIT/DUPLEX/REPEATER MODE ICONS**  
Displayed when the Split or Duplex (DUP-/DUP+) function is ON, or “RPS” is displayed while using the Repeater Simplex mode (RPS) in the DD mode.

# 1 PANEL DESCRIPTION

## Touch screen display

### ◇ FUNCTION screen

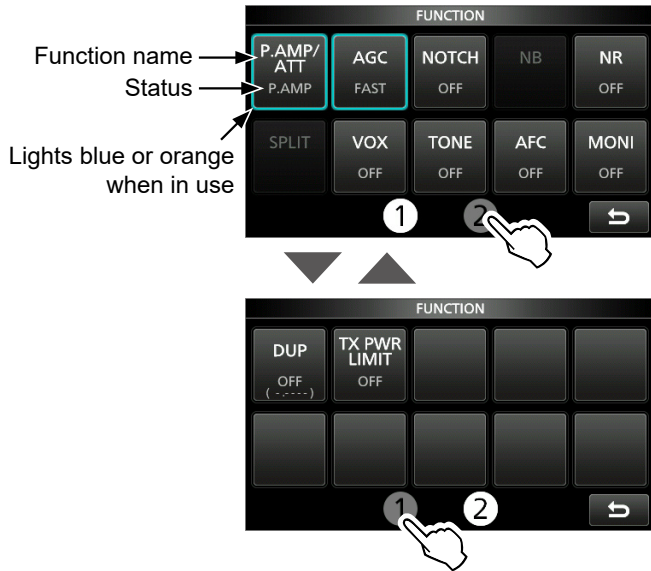

### ◇ MENU screen



- Push **FUNCTION** to open the FUNCTION screen in the selected mode.
  - ① To close the FUNCTION screen, push **EXIT**.
  - ① Touching [1] or [2] at the bottom of the screen selects FUNCTION screen 1 or 2.

- Push **MENU** to open the MENU screen in the selected mode.
  - ① To close the MENU screen, push **EXIT**.
  - ① Touching [1] or [2] at the bottom of the screen selects MENU screen 1 or 2.

### FUNCTION screen list

- \*1 Touch for 1 second to select the function.
- \*2 Touch for 1 second to open its function menu.
- \*3 Touch for 1 second to turn ON the Quick Split function.

P.AMP/ATT	AGC*2	NOTCH*2	NB*2
OFF	FAST	OFF	OFF
P.AMP	MID	AN	ON
ATT*1	SLOW	MN	
NR*2	SPLIT*3	VOX*2	BKIN*2
OFF	OFF	OFF	OFF
ON	ON	ON	BKIN
			F-BKIN
COMP	TONE*2		
OFF	OFF	DTCS (T)	
ON	TONE	TONE (T)/DTCS (R)	
	TSQL	DTCS (T)/TSQL (R)	
	DTCS	TONE (T)/TSQL (R)	
D.SQL*2	TBW	1/4	AFC
OFF	WIDE	OFF	OFF
DSQL	MID	ON	ON
CSQL	NAR		
MONI*2	DUP*2	RPS	TX PWR LIMIT*2
OFF	OFF	OFF	OFF
ON	DUP-	ON	ON
	DUP+		

### ◇ QUICK MENU

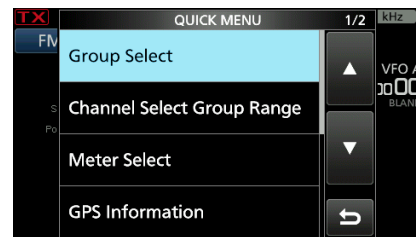

- Push **QUICK** to open the QUICK MENU screen.

Touch screen display

◇ Multi-function menus

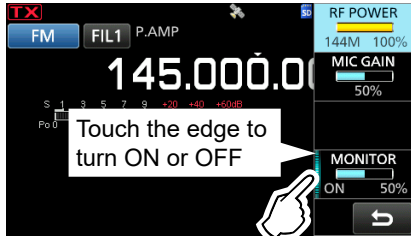

- Open the Multi-function menu by pushing **Ⓜ** (Multi-function control).
- Open special menus by holding down **VOX/BK-IN** for 1 second.
- While the Multi-function menu is open, touch the desired item and rotate **Ⓜ** to set the desired value.

Multi-function menu items

\*1 Touch the item for 1 second to adjust by rotating **Ⓜ**, even when the Multi-function menu is closed.

\*2 Touch the edge to turn the function ON or OFF, or to adjust the selected item.

SSB	SSB-D	CW	RTTY
RF POWER*1	RF POWER*1	RF POWER*1	RF POWER*1
MIC GAIN*1	MIC GAIN*1	KEY SPEED*1	TPF*2
COMP*1*2		CW PITCH*1	
MONITOR*1*2	MONITOR*1*2		MONITOR*1*2
FM/AM/DV	DD	ATV	NB
RF POWER*1	RF POWER*1	RF POWER*1	LEVEL*1
MIC GAIN*1	TX INHIBIT*2	MIC GAIN*1	DEPTH*1
			WIDTH*1
MONITOR*1*2	MONITOR*1*2	MONITOR*1*2	
NR	NOTCH	VOX	BK-IN
LEVEL*1	POSITION*1	GAIN*1	DELAY*1
	WIDTH*2	ANTI VOX*1	
		DELAY*1	
		VOICE DELAY*2	
TX PWR LIMIT			
RF POWER*1			
LIMIT			

Multi-function dial

When the Multi-function menu is closed, the **Ⓜ** control can be enabled to adjust functions by pushing **RIT/ΔTX** or touching the item for 1 second on the Multi-function menus.

The function is displayed in the upper right corner of the screen.

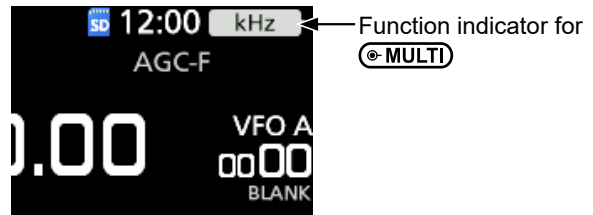

\*3 Touch the function indicator or hold down **Ⓜ** for 1 second to assign the function to the **Ⓜ** control, when the RIT or ΔTX function is OFF.

\*4 On the Multi-function menus, touch the item for 1 second to assign the function to the **Ⓜ** control.

Indicator	Action	
RIT	Rotate	Adjusts the RIT frequency.
	Hold down	Clears the RIT frequency.
ΔTX	Rotate	Adjusts the ΔTX frequency.
	Hold down	Clears the ΔTX frequency.
kHz*3	Changes the operating frequency in kHz steps. (VFO mode only)	
MHz*3	Changes the operating frequency in MHz steps. (VFO mode only)	
M-CH*3	Selects Memory channels. (Memory mode and Call channel mode only) When using the DR function, selects an individual station or preset repeater.	
RF PWR*4	Adjusts the transmit output power.	
MIC G*4	Adjusts the microphone gain.	
COMP*4	Adjusts the Speech Compressor level.	
MONI*4	Adjusts the audio level for the Monitor function.	
SPEED*4	Adjusts the Keying speed.	
PITCH*4	Adjusts the CW pitch.	
NB LEV*4	Adjusts the Noise Blanker level.	
NB DEP*4	Adjusts the DEPTH (Noise attenuation level).	
NB WID*4	Adjusts the WIDTH (Blanking duration time).	
NR LEV*4	Adjusts the Noise Reduction level.	
NOTCH*4	Adjusts the Notch filter frequency.	
VOX G*4	Adjusts the VOX gain.	
A-VOX*4	Adjusts the ANTI VOX level	
VOX D*4	Adjusts the VOX delay time.	
BKIN D*4	Adjusts the Break-in delay time.	

## Selecting a location

Select a location for the transceiver that allows adequate air circulation, free from extreme heat, cold, or vibration, and other electromagnetic sources.

Never place the transceiver in areas such as:

- Out of the specified temperature range for the controller (0°C ~ 50°C, 32°F ~ 122°F) and the RF unit (-10°C ~ +55°C, 14°F ~ 131°F).
- An unstable place that slopes or vibrates.
- In direct sunlight.
- High humidity and temperature environments.
- Dusty environments.
- Noisy environments.

## Heat dissipation

- **NEVER** install the transceiver in an insecure place to avoid touching the heat sink on the controller's rear panel and the RF unit and to avoid operation by unauthorized persons.
- **NEVER** install the transceiver in a place without adequate ventilation. Heat dissipation may be reduced, and the transceiver may be damaged.
- **DO NOT** place the transceiver against walls or put anything around the transceiver. This may block airflow and overheat the transceiver.



**CAUTION:** Hot surfaces. **DO NOT** touch the transceiver's surface after continuously transmitting for long periods of time. The transceiver's chassis radiates heat, and it will become hot to protect the power amplifier unit from overheating. Touching it may cause a burn.

## Attaching the cushions

Attach the cushions, as illustrated below.

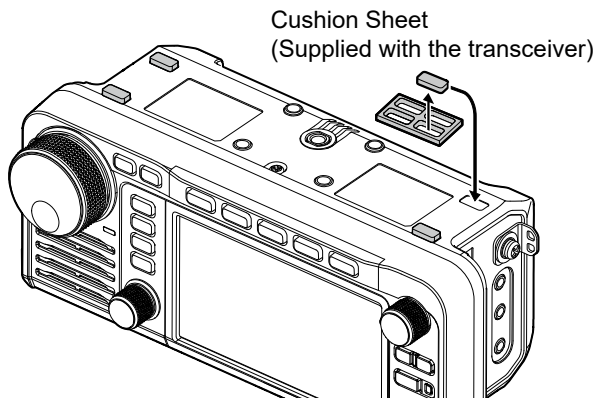

## Connecting a microphone

Plug the microphone into the [MIC-SP] jack and the [MIC] jack, and attach the microphone's cable to the microphone plate to avoid cable breaks.

① Confirm that the transceiver is OFF before connecting or disconnecting optional equipment.

1. Attach the microphone's split ring to the plate.
2. Plug the microphone into the [MIC-SP] jack and the [MIC] jack.  
(MIC-SP: 3.5 mm (1/8 inch), MIC: 2.5 mm)

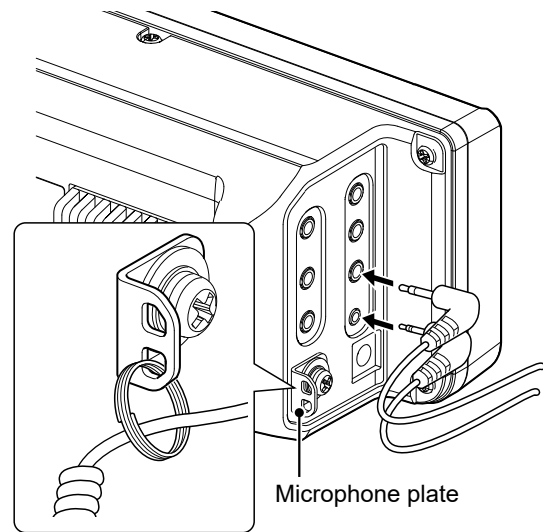

① When you connect other devices to the [MIC-SP] jack and the [MIC] jack, attach the cable to the plate through the split ring (User supplied).

## [DC 13.8 V]

Accepts regulated DC power of 13.8 V DC ±15% through the supplied DC power cable.

### ⚠ WARNING!

- **NEVER** reverse the DC power cable polarity.
- **NEVER** remove the fuse holder on the DC power cable.
- **NEVER** use other than specified DC power cable.
- **NEVER** modify, bend by force, twist, pull or heat the DC power cable.
- **NEVER** put something heavy on the DC power cable.

## Connecting an external DC power supply

Confirm that the transceiver is OFF before connecting the DC power cable.

① When connecting a DC power cable, the transceiver needs:

- DC 13.8 V (Capacity: At least 5 Amps)
- A power supply with an over current protective line, and low voltage fluctuation or ripple.

**CAUTION: DO NOT** touch the transceiver's surface when disconnecting the cable immediately after operation. The transceiver's surface becomes hot after continuously transmitting for long periods of time.

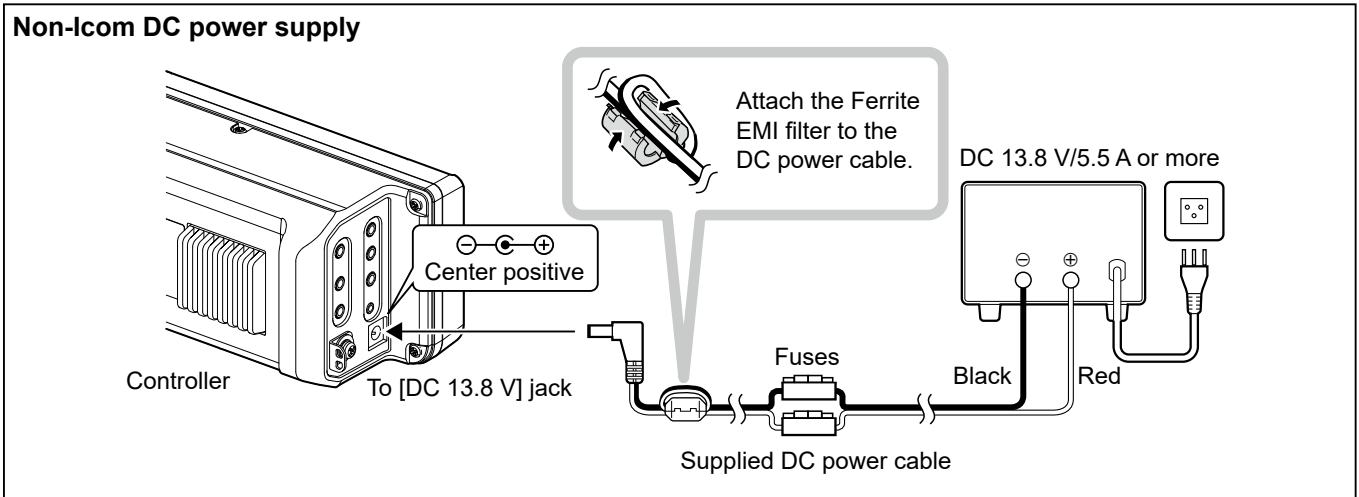

## When first applying power

Before turning ON your transceiver for the first time, make sure all connections are correctly made.

**TIP:** When you turn OFF the transceiver, it memorizes the current settings. Therefore, when you turn ON the transceiver again, it restarts with the same settings.

## Turning power ON or OFF

- To turn ON the transceiver, push **[POWER]**.
- To turn OFF the transceiver, hold down **[POWER]** for 1 second until "POWER OFF..." is displayed.

## Adjusting the volume level

Rotate **[AF/RF/SQL]** to adjust the volume level.

## Selecting the mode

### VFO mode

Set the desired frequency by rotating **[MAIN DIAL]**.

### Memory mode

Enter contents into the desired channel in the MEMORY list.

### Call channel mode

Call channels (or Main channel) are used to call on an often used frequency. Two Call channels are assigned on each band.

### Selecting the VFO, Memory, or Call channel mode

1. Touch the VFO/MEMORY icon.

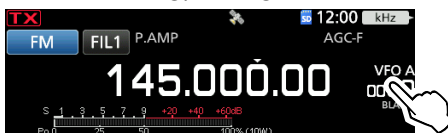

- Opens the VFO/MEMORY screen.
2. Touch [VFO], [MEMO], or [CALL].

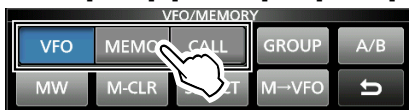

- ① You can also select the Call channel mode by pushing **[CALL]**.

## Using the VFO mode

The IC-905 has 2 Variable Frequency Oscillators (VFO), "A" and "B." Having 2 VFOs is convenient to quickly select 2 frequencies, or for split frequency operation (p. 4-11). You can use either of the VFOs to operate on a frequency and mode.

### ◇ Selecting VFO A or VFO B

1. Touch the VFO/MEMORY icon.
  - Opens the VFO/MEMORY screen.
2. Touch [A/B] to select VFO A or VFO B.



### ◇ Equalizing VFO A and VFO B

You can set the displayed VFO's frequency to the VFO that is not displayed.

1. Touch the VFO/MEMORY icon.
  - Opens the VFO/MEMORY screen.
2. Touch [A/B] for 1 second.





## Selecting the operating band

Do the following steps to change the operating band.

1. Touch the MHz digits. (Example: 145)

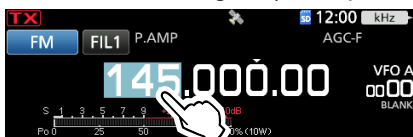

- Opens the BAND STACKING REGISTER screen.

2. Touch a band key. (Example: 1200)

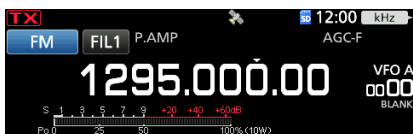

- Displays a 1200 MHz frequency.

### TIP: About the Band Stacking Register

The Band Stacking Register provides 3 memories for each band. When you change the operating band or the Register, the previously operated frequency and mode are stored.

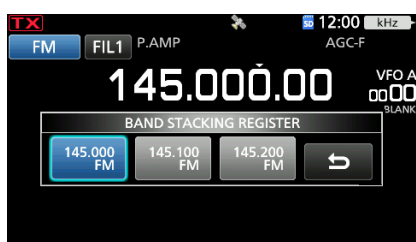

To display the Band Stacking Register contents:

- Touch the band key for 1 second in step 2.
- Touch the MHz digits for 1 second on the standby screen.\*

- ① Touch to return to the previous screen.

\* Only when “Function of Touch for 1 sec MHz Digits” is set to “Band Stacking Register.”

**[MENU]** » SET > Function > **Function of Touch for 1 sec MHz Digits**

## Selecting the operating mode

You can select between the SSB (LSB/USB), SSB data (LSB-DATA/USB-DATA), CW, CW reverse, RTTY, RTTY reverse, AM, AM data (AM-DATA), FM, FM data (FM-DATA), DV, DD\*, and ATV\* modes.

\* Only for the 1200 MHz and higher bands

1. Touch the mode icon (Example: FM).

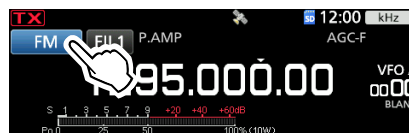

- Opens the MODE screen.

2. On the MODE screen, touch the desired mode key. (Example: CW).



- ① In the SSB, AM, or FM modes, the [DATA] key is displayed.

- ① In the DV mode, the [GPS] key is displayed. When the GPS TX mode is selected, is displayed on the operating mode indicator.

### Operating mode selection list

- ① Touch mode key to select the operating mode.

Mode key	Operating mode	
[SSB]	USB	LSB
[CW]	CW	CW-R
[RTTY]	RTTY	RTTY-R
[AM]	AM	
[FM]	FM	
[DV]	DV	
[DD]	DD	
[ATV]	ATV	
[DATA]	LSB	LSB-D
	USB	USB-D
	AM	AM-D
	FM	FM-D

### Selecting the Data mode

You can operate data communications (SSTV, RTTY (AFSK), PSK31, JT65B, and FT8).

- ① When a data mode is selected, you can mute the input from the microphone.

**[MENU]** » SET > Connectors > MOD Input > **DATA MOD**

- ① In the PRESET menu, you can save the combination of the settings for the data mode to quickly change the settings, depending on your operating needs. See the Advanced manual for details.

## Setting the frequency

### ◇ Using the Main Dial

1. Select the desired operating band. (p. 3-2)
2. Rotate **(MAIN DIAL)**.
  - The frequency changes according to the selected Tuning Step.
  - ① **TX** is displayed when you select an amateur radio frequency, and **TX** (with a dotted line) is displayed when you select a frequency outside the Ham band, or outside your set Band Edges.

### ◇ About the Tuning Step function

You can set the **(MAIN DIAL)**'s tuning step for each operating mode.  
 Touch the kHz digits to turn the Tuning Step function ON or OFF.

- ① The Tuning Step function's icon "▼" is displayed above the 1 kHz digit.

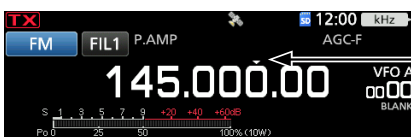
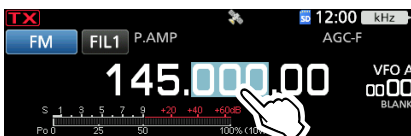

The Tuning Step function is ON.

### ◇ Changing the Tuning Step

When the Tuning Step function is ON, you can change the tuning steps for each operating mode.

1. Select the desired operating mode. (p. 3-2)  
(Example: FM)
2. Touch the kHz digit for 1 second.



- Opens the TS (FM) screen.
3. Touch the desired tuning step. (Example: 0.1 k)



- The tuning step is set, and returns to the previous screen.

### ◇ About the 1 MHz Step Tuning function

You can use the maximum tuning step of 1 MHz.

Touch the MHz digits for 1 second to turn the 1 MHz Step Tuning function ON or OFF.

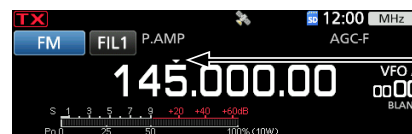
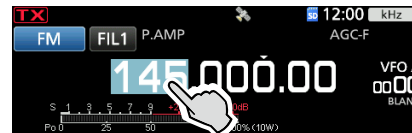

The 1 MHz Step Tuning function is ON.

### ◇ About the 1 Hz step Fine Tuning function

You can use the minimum tuning step of 1 Hz for fine tuning.

Touch the Hz digits for 1 second to turn the Fine Tuning function ON or OFF.

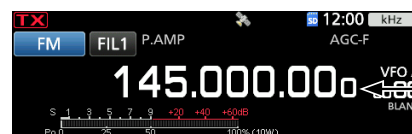
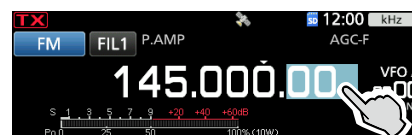

The 1 Hz digit is displayed.

Setting the frequency

◇ About the 1/4 Tuning function

**SSB-D, CW, and RTTY modes**

With the Tuning Function OFF, turn ON the 1/4 Tuning function to reduce the tuning speed to 1/4 of the normal speed, for finer tuning.

1. Push **FUNCTION**.
  - Opens the FUNCTION screen.
2. Touch [1/4].



3. Push **EXIT**.

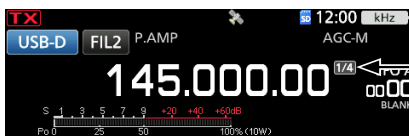

1/4 Tuning function is ON.

◇ About the Auto Tuning Step function

The tuning step automatically changes, depending on the rotation speed of **MAIN DIAL**.

- ① You can change the Auto Tuning Step function settings in the following menu. (p. 8-5)

**MENU** » **SET > Function > MAIN DIAL Auto TS**

◇ Directly entering a frequency

You can set the frequency without rotating **MAIN DIAL** by directly entering it using the keypad.

**Entering the operating frequency**

1. Touch the MHz digits. (Example: 145)
  - Opens the BAND STACKING REGISTER screen.
2. Touch [F-INP].



- Opens the F-INP screen.
3. Start entry with the most significant digit.



- ① To clear the entry, touch [CE].
- ① To clear the entry and return to the previous screen, push **EXIT**.
4. Touch [ENT] to set the entered frequency. Closes the F-INP screen.
  - ① If you touch [ENT] when the digits under 100 kHz are not entered, "0" will be automatically entered into the digits that are blank.

**Entry examples**

- 144.680 MHz: [1], [4], [4], [**•(-)**], [6], [8], [0], [ENT]
- 145.000 MHz: [1], [4], [5] [ENT]
- Changing from 144.680 MHz to 144.540 MHz: [**•(-)**], [5], [4], [0], [ENT]
  - ① Touching [**•(-)**] first enters the same MHz digits as the operating frequency.

### 3 BASIC OPERATION

#### Setting the frequency

◇ Directly entering a frequency

#### Entering the Split Frequency Offset

1. Touch the MHz digits. (Example: 145)
  - Opens the BAND STACKING REGISTER screen.
2. Touch [F-INP].



- Opens the F-INP screen.
3. Enter the Split Frequency Offset.



#### ① Information

- If you want the minus shift direction, touch [\*(-)].
  - Enter the offset between -9.999 MHz and +9.999 MHz (1 kHz steps).
  - To clear the entry, touch [CE].
  - To clear the entry and return to the previous screen, push [EXIT].
  - After entering, the Split function is automatically turned ON.
4. To save the entry, touch [SPLIT] or [-SPLIT].
    - Closes the F-INP screen.

#### Entry examples

- 5 kHz: [5], [SPLIT]
- -10 kHz: [\*(-)], [1], [0], [-SPLIT]

**NOTE:** If the entered operating frequency is out of an amateur band's frequency range, the transmit frequency is automatically set to the band edge frequency.

#### Selecting a Memory channel by number

1. Select the Memory mode. (p. 3-1)
2. Select a memory group.
  - ① To select a memory group, touch the VFO/MEMORY icon, and then touch [GROUP].
3. Touch the MHz digits. (Example: 145)

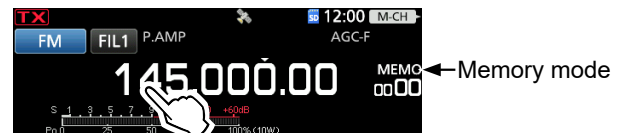

- Opens the BAND STACKING REGISTER screen.
4. Touch [F-INP].



- Opens the F-INP screen.
5. Enter a Memory channel number. (Example: 2)



- ① If the Call channel group is selected, enter between "0" and "11."

- 0: 144 C1
- 1: 144 C2
- 2: 430 C1
- 3: 430 C2
- 4: 1200 C1
- 5: 1200 C2
- 6: 2400 C1
- 7: 2400 C2
- 8: 5600 C1
- 9: 5600 C2
- 10: 10G C1
- 11: 10G C2

6. Touch [MEMO] to set the memory channel of the entered number.
  - Closes the F-INP screen.
  - The selected memory channel contents are displayed.

Setting the frequency

◇ Band Edge Beep

You will hear a Band Edge Beep and **TX** (with a dotted line) will be displayed when you tune into or out of an amateur band's frequency range.

① You can change the Band Edge Beep settings in the following menu.

**MENU** » **SET > Function > Band Edge Beep**

① If "Beep Level" is set to "0%," no beep sounds.

**MENU** » **SET > Function > Beep Level**

◇ Entering a Band Edge

When "ON (User)" or "ON (User) & TX Limit" is selected on the "Band Edge Beep" screen, you can enter a total of 30 band edge frequency pairs.

① Information

- Initially, all Ham band frequencies are entered. Therefore, you must first edit or delete them, and then insert a new line to enter a new band edge.
- You cannot enter an overlapping frequency, or a frequency that is out of the preset Ham band frequencies.
- The default setting may differ, depending on the transceiver version.
- Band edges are entered from the lower frequency first.
- These settings are easy with the CS-905. (p. 12-1)

1. Open the "Band Edge Beep" screen.

**MENU** » **SET > Function > Band Edge Beep**

2. Touch "ON (User)" or "ON (User) & TX Limit."

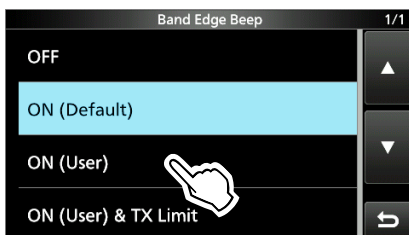

① If you set "ON (User) & TX Limit," you can limit transmission to within the entered frequency range.

3. Touch "User Band Edge."

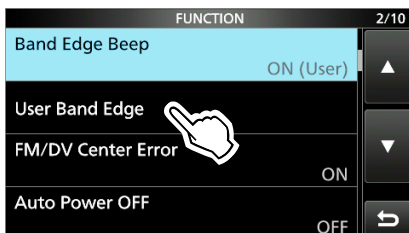

- Opens the "User Band Edge" screen.

Editing a Band Edge

You can edit a band edge entered as a default, or change the band edge frequencies.

1. Open the "User Band Edge" screen.
2. Touch the band edge you want to edit. (Example: 2: 430.000.000 – 450.000.000 MHz)

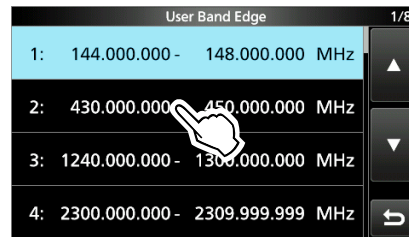

3. Edit the lower band edge frequency, then touch [ENT]. (Example: 430.1)  
Entry example: [.] [1] [ENT]



4. Edit the upper band edge frequency, then touch [ENT]. (Example: 439.9)  
Entry example: [4] [3] [9] [.] [9] [ENT]

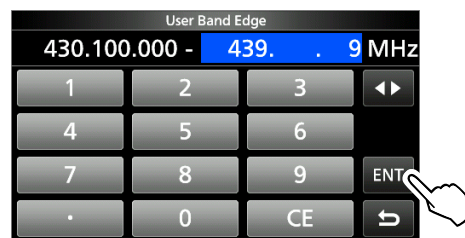

- The edited band edge is saved, and returns to the previous screen.

**TIP:** You can also edit the frequency by rotating **MAIN DIAL** or **MULTI**.

### 3 BASIC OPERATION

#### Setting the frequency

#### ◇ Band Edge Beep

##### Deleting a Band Edge

You can delete band edges you no longer need.

1. Open the “User Band Edge” screen.
2. Touch the desired band edge to delete for 1 second.  
(Example: 7: 10000.000.000 – 10500.000.000 MHz)

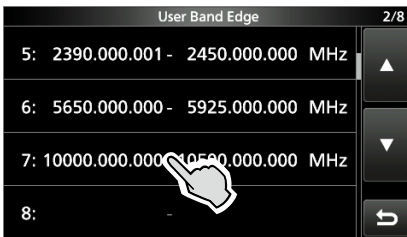

3. Touch “Delete.”



- The selected band edge is deleted, and returns to the previous screen.

##### Entering a new Band Edge

You can enter new Band Edge frequencies into a blank band edge line.

1. Open the “User Band Edge” screen.
2. Touch a blank band. (Example: 7)

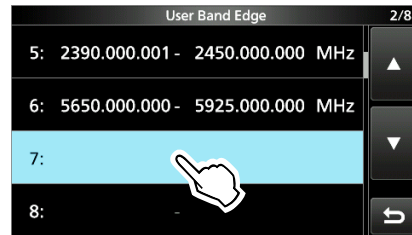

3. Enter the lower band edge frequency, then touch [ENT]. (Example: 10000)  
Entry example: [1] [0] [0] [0] [0] [ENT]



4. Enter the upper band edge frequency, then touch [ENT]. (Example: 10450.5)  
Entry example: [1] [0] [4] [5] [0] [.] [5] [ENT]



- The entered band edge is saved, and returns to the previous screen.

Setting the frequency

**Inserting a Band Edge**

You can insert a new Band Edge line, and enter new band frequencies, between two entered band edges.

1. Open the "User Band Edge" screen.
2. Touch the band edge you want to insert a new band edge above, for 1 second.  
(Example: 3: 1240.000.000 – 1300.000.000 MHz)

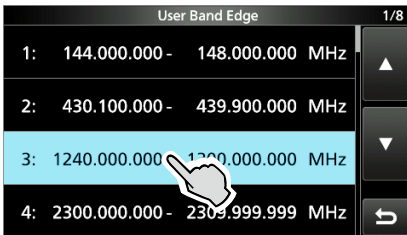

① The new band edge will be inserted above the selected band edge.

3. Touch "Insert."



4. Enter the lower band edge frequency then touch [ENT]. (Example: 439.915)  
Entry example: [4] [3] [9] [.] [9] [1] [5] [ENT]

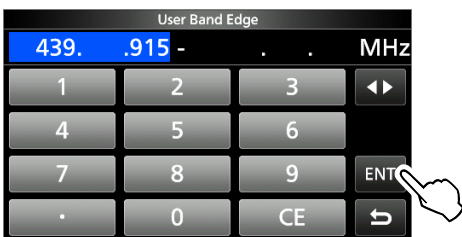

5. Enter the upper band edge frequency, then touch [ENT]. (Example: 439.95)  
Entry example: [.] [9] [5] [ENT]



• The entered band edge is saved, and returns to the previous screen.

**Resetting all band edges to their defaults**

The steps below will reset all the band edges to their initial settings. All entered settings will be deleted.

1. Open the "User Band Edge" screen.
2. Touch any band edge for 1 second.

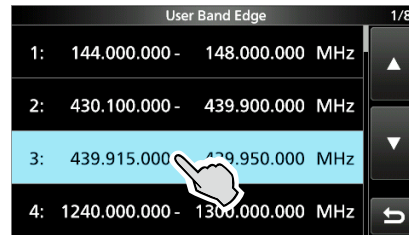

3. Touch "Default."



4. Touch [YES].



• All the band edges reset to the initial settings.

**Dial Lock function**

The Dial Lock function prevents frequency changes caused by accidentally moving (MAIN DIAL).

① This function electronically locks the dial.

Hold down **[SPEECH]** for 1 second to turn the Dial Lock function ON or OFF.

① You can select the Dial lock or Panel lock. (p. 8-5)

**[MENU]** » **[SET > Function > Lock Function]**

## RF gain and SQL level

1. Push **(AF/RF/SQL)**.
2. Touch an item to adjust. (Example: RF GAIN)

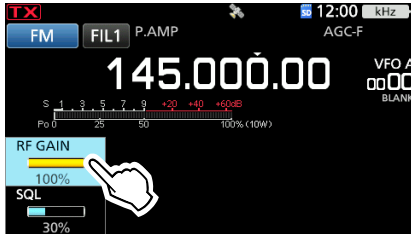

3. Rotate **(AF/RF/SQL)**.

### RF gain

You can adjust the receive sensitivity.

If a strong interfering signal is received, rotate **(AF/RF/SQL)** counterclockwise to reduce the RF gain.

- ① "RFG" is displayed when the RF gain is reduced.
- ① If a strong signal is received and "OVF" (Overflow) is displayed, reduce the RF gain until "OVF" disappears.

### Squelch (SQL) level

There are 2 types of SQL levels, depending on the operating mode.

#### • Noise squelch

Rotate **(AF/RF/SQL)** until the noise just disappears and the RX indicator goes OFF.

- ① Activates when the squelch level is set to between 30% and 50% in the FM or DV mode.

#### • S-meter squelch

The S-meter squelch disables the audio output from the speaker or headphones when the received signal is weaker than the specified S-meter squelch level.

Rotate **(AF/RF/SQL)** clockwise to increase the S-meter threshold level.

- ① Activates when the squelch level is set to between 50% and 100% in any mode.

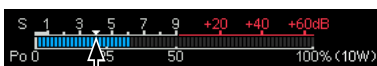

S-meter squelch level

## Adjusting the microphone gain

1. Set the operating band and mode to SSB, AM, FM, DV, or ATV. (p. 3-2)
2. Push **(MULTI)** to open the Multi-function menu.
3. Hold down **[PTT]**.
4. Touch **[MIC GAIN]**, and rotate **(MULTI)** to adjust the microphone gain.



### Information

- Hold the microphone 5 to 10 cm (2 to 4 inches) from your mouth, then hold down **[PTT]** on the microphone and speak at your normal voice level.
  - In the SSB mode, touch the TX meter to select the ALC meter, and rotate to adjust the microphone gain until the meter reading swings between 30 to 50% of the ALC scale.
  - In the AM, FM, DV, or ATV mode, check the audio clarity with another station, or use the Monitor function (p. 4-2).
5. Release **[PTT]**.
    - Returns to receive.



## Meter display

### ◇ Meter display selection

You can display one of the 6 different transmit parameters (Po, SWR, ALC, COMP, V<sub>D</sub>, and I<sub>D</sub>) for your convenience.

Touch the parameter to display one of the meters.

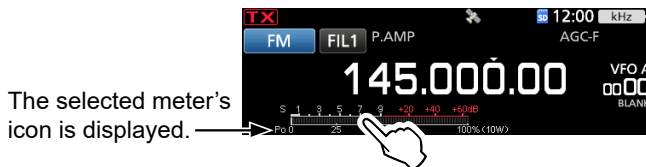

The selected meter's icon is displayed.

### ◇ Multi-function meter

You can simultaneously display all the parameters.

- ① The TEMP meter is also displayed on the Multi-function meter.
- ① You can select whether to display the V<sub>D</sub> or DC IN meter.

**MENU** » **SET > Display > Multi-func. Meter Voltage Display**

Touch the currently displayed parameter for 1 second to display the Multi-function meter.

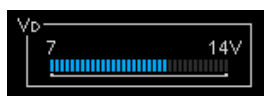
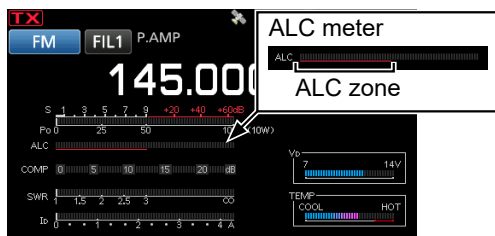

TX inhibit zone  
Displays the temperature of the final amplifier MOS-FETs.

**S:** Displays the receiving signal strength level.

**Po:** Displays the relative RF output power.

**SWR:** Displays the SWR of the antenna at the displayed frequency.  
① In the 10 GHz band, you cannot measure the SWR.

**ALC:** Displays the ALC level. When the meter movement shows the input signal level exceeds the allowed level, the ALC limits the RF power. In such case, decrease the microphone gain level.

**COMP:** Displays the compression level when the speech compressor is used.

**V<sub>D</sub>:** Displays the drain voltage of the final amplifier MOS-FETs.  
① In the 10 GHz band, the drain voltage is displayed only while transmitting, because the power amplifier control method is different from other bands.

**I<sub>D</sub>:** Displays the drain current of the final amplifier MOS-FETs.

**TEMP:** Displays the temperature of the final amplifier MOS-FETs.

**DC IN:** Displays the voltage of the external power source.

### When the DC IN meter is displayed:

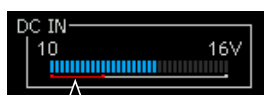

When the DC IN meter reads above only the red under line, the output power may decrease, or transceiver power may be shut down.

## Adjusting the transmit output power

Before transmitting, monitor your selected operating frequency to make sure you do not cause interference to other stations on the same frequency. It is good amateur practice to listen first, and then, even if nothing is heard, ask if the frequency in use once or twice, before you start operating.

1. Select the operating mode. (p. 3-2)  
(Example: RTTY)
2. Touch the meter to display the Po meter. (p. 3-10)

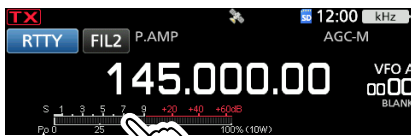

"Po" is displayed.

3. Push **[MULTI]** to open the Multi-function menu.
4. Hold down **[PTT]**.
  - The TX indicator lights red, and **TX** is displayed.
  - The Po meter level changes according to your voice level in the SSB mode. It becomes the S-meter while receiving.
5. Touch **[RF POWER]**, and rotate **[MULTI]** to adjust the transmit output power between 0 and 100% (in 1% steps).

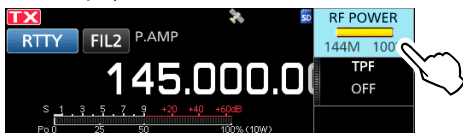

6. Release **[PTT]**.
    - Returns to receive.
- ① In the AM mode, the maximum transmit output power is a quarter of the other mode's output.  
 ② The transmit output power is limited to the maximum transmit output power.

## Transmit Power Limit function

The Transmit Power Limit function limits the output power to the preset level for each band.

1. Select the operating band. (p. 3-2)
2. Push to **[FUNCTION]** open the FUNCTION screen.
3. Touch ② at the bottom of the screen.
4. Touch **[TX PWR LIMIT]**.

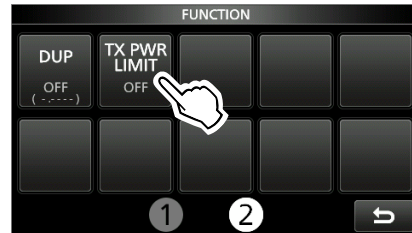

- Touching **[TX PWR LIMIT]** turns the function ON or OFF.

5. Touch **[TX PWR LIMIT]** for 1 second.

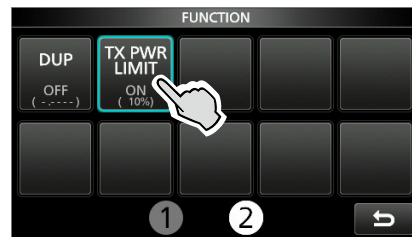

6. Rotate **[MULTI]** to set the maximum transmit power to between 0 and 100% (in 1% steps).

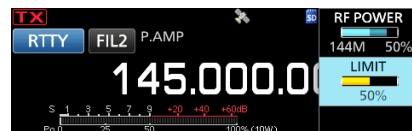

7. Push **[MULTI]** to close the Multi-function menu.

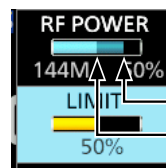

Set transmit power

Limited transmit power (LIMIT value)

① Even when set RF POWER exceeds "LIMIT," the actual output power is limited to this value.

## Preamplifiers

### 144, 430, and 1200 MHz bands

The preamp amplifies received signals in the receiver front end to improve the signal-to-noise ratio and sensitivity. A preamp is used when receiving weak signals.

① Each band memorizes the Preamplifier setting.

1. Select the operating band.
2. Push **[FUNCTION]**.
  - Opens the FUNCTION screen.
3. Touch [P.AMP/ATT] to turn this function ON or OFF.



4. To close the FUNCTION screen, push **[EXIT]**.

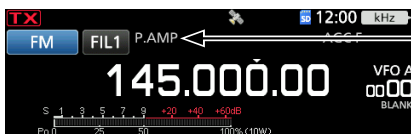

Displayed when a preamp is ON.

**NOTE:** When you use the preamp while receiving strong signals, the receiving signal may be distorted. In such case, turn OFF the preamp.

## Attenuator

### 144, 430, and 1200 MHz bands

The Attenuator prevents a desired signal from becoming distorted when a very strong signal is near the frequency, or when a very strong electric field, such as from a broadcasting station, is near your location.

① Each band memorizes the Preamplifier setting.

1. Select the operating band.
2. Push **[FUNCTION]**.
  - Opens the FUNCTION screen.
3. Touch [P.AMP/ATT] for 1 second.



① Touching [P.AMP/ATT] again turns OFF the Attenuator.

4. To close the FUNCTION screen, push **[EXIT]**.



Displayed when the Attenuator is ON.

① If a strong signal is received and "OVF" (Overflow) is displayed, turn ON the attenuator, or reduce the RF gain until "OVF" disappears. (p. 3-9)

## RIT function

The Receiver Incremental Tuning (RIT) function compensates for differences in frequencies of other stations.

The function shifts your receive frequency up to  $\pm 9.99$  kHz without shifting the transmit frequency.

1. Push **[RIT/ΔTX]**.

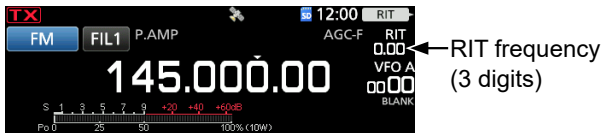

- The RIT function turns ON.

① If the **ΔTX** function turns ON, hold down **[RIT/ΔTX]** for 1 second.

① While using the Fine Tuning function (p. 3-3), the RIT frequency is displayed in 4 digits, instead of 3.

① Pushing **[RIT/ΔTX]** again turns OFF the RIT function.

2. Rotate **[MULTI]** to set the RIT frequency to match the received station's transmit frequency.

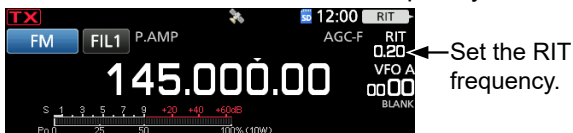

① You can reset the RIT frequency to "0.00" by holding down **[MULTI]** for 1 second.

3. After communicating, push **[RIT/ΔTX]** to turn the RIT function OFF.

### ◇ RIT monitor function

When the RIT function is ON, you can directly monitor the operating frequency by holding down **[XFC]**.

① While monitoring, the RIT function is temporarily turned OFF.

① While monitoring, the Noise Reduction, Notch filter, and Twin PBT settings are temporarily turned OFF.

## Monitor function

### SSB, CW, RTTY, AM, FM, DV, and ATV modes

The Monitor function enables you to monitor your transmit audio. Use this function to check the voice characteristics while adjusting transmit audio parameters.

① You can hear the CW sidetone regardless of the Monitor function setting.

1. Select the operating mode that you want to monitor. (Example: FM)
2. Push **[FUNCTION]**.
  - Opens the FUNCTION screen.
3. Touch **[MONI]** to turn ON the Monitor function.



① Touching **[MONI]** turns the Monitor function ON or OFF.

4. If you want to adjust the monitor audio output, touch **[MONI]** for 1 second.



5. Rotate **[MULTI]** to adjust MONITOR to the clearest audio output between 0% and 100%, while speaking at your normal voice level.

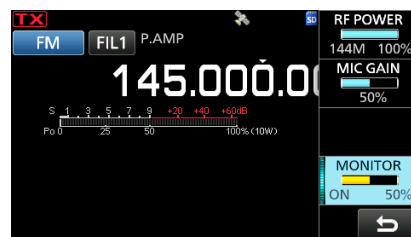

6. To close the Multi-function menu, push **[MULTI]**.

**NOTE:** When using the VOX function, turn OFF the Monitor function. Otherwise, the transmitted audio will echo.

## AFC function

### FM and DV modes

The Automatic Frequency Control (AFC) function tunes the receive frequency to the incoming signal.

- ① This function activates regardless of the squelch condition.
- ① When the Split function is ON, the transmit frequency is not tuned into the incoming signal.
- Push **[AFC]**.
  - Pushing **[AFC]** turns the AFC function ON or OFF.

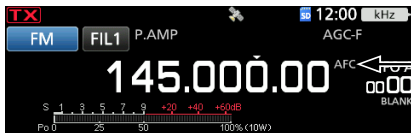

Displayed when the AFC function is ON.

- ① You can also turn the AFC function ON or OFF on the FUNCTION screen.
- ① You can select whether or not to limit the operating range for this function. (Default: ON)

**[MENU]** » **SET > Function > AFC Limit**

When "AFC Limit" is set to "OFF," this function may tune the receive frequency to a strong signal near the desired signal.

## AGC function control

### SSB, CW, RTTY, and AM modes

The Automatic Gain Control (AGC) function controls receiver gain to produce a constant audio output level, even when the received signal strength greatly varies.

① Each mode and band memorizes the AGC setting.

### ◇ Selecting the AGC time constant preset value

The transceiver has FAST, MID, and SLOW preset AGC settings for all modes, except the FM, DV, DD, and ATV modes.

1. Select the operating band and mode.  
(Example: SSB, 144 MHz band)
2. Push **[FUNCTION]**.
  - Opens the FUNCTION screen.
3. Touch **[AGC]** to select the desired time constant.



- ① Touching **[AGC]** selects FAST, MID, or SLOW.
- ① For FM, DV, DD, and ATV modes, FAST is fixed.

4. To close the FUNCTION screen, push **[EXIT]**.

**NOTE:** While you are receiving weak signals, and a strong signal is momentarily received, the AGC function quickly reduces the receiver gain. When that signal disappears, the transceiver may not receive the weak signal because of the AGC action. In that case, select FAST, or touch **[AGC]** for 1 second to open the AGC screen, and then select OFF.

### ◇ Setting the AGC time constant

You can set the preset AGC time constant to a desired value.

1. Select the operating mode. (Example: SSB)
2. Push **[FUNCTION]**.
  - Opens the FUNCTION screen.
3. Touch **[AGC]** for 1 second.



- Opens the AGC (SSB) screen.
4. Touch FAST, MID, or SLOW. (Example: MID)

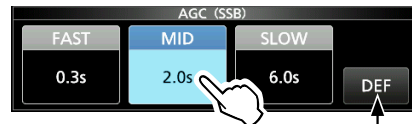

You can reset to the default setting by touching this key for 1 second.

5. Rotate **[MAIN DIAL]** to set the time constant.
6. To close the AGC (SSB) screen, push **[EXIT]**.

### Selectable AGC Time constant (unit: seconds)

Mode	Default	Adjustable time constant
LSB USB	0.3 (FAST)	OFF, 0.1, 0.2, 0.3, 0.5, 0.8, 1.2, 1.6, 2.0, 2.5, 3.0, 4.0, 5.0, or 6.0
	2.0 (MID)	
	6.0 (SLOW)	
CW/ RTTY	0.1 (FAST)	OFF, 0.1, 0.2, 0.3, 0.5, 0.8, 1.2, 1.6, 2.0, 2.5, 3.0, 4.0, 5.0, or 6.0
	0.5 (MID)	
	1.2 (SLOW)	
AM	3.0 (FAST)	OFF, 0.3, 0.5, 0.8, 1.2, 1.6, 2.0, 2.5, 3.0, 4.0, 5.0, 6.0, 7.0, or 8.0
	5.0 (MID)	
	7.0 (SLOW)	
FM/DV/ DD/ATV	0.1 (FAST)	Fixed

## Using the Digital Twin PBT

### SSB, CW, RTTY, and AM modes

To reject interference, the Digital Twin Passband Tuning (PBT) narrows the IF passband width by electronically shifting the IF frequency to slightly above or below the IF center frequency. The IC-905 uses the digital function using the FPGA (Field Programmable Gate Array) filtering method.

① Each mode memorizes the PBT setting.

1. Push **(TWIN PBT)** to select "PBT1."  
 ① Each push selects "PBT1" or "PBT2."



2. Rotate **(TWIN PBT)** to adjust the shift value.
  - The passband width and shift value are displayed.
  - Hold down **(TWIN PBT)** for 1 second to clear the PBT setting.
3. Repeat steps 1 and 2 to adjust the shift value for "PBT2."

### ① Information

- To narrow the IF passband width, shift "PBT1" and "PBT2" to the opposite direction from each other, to narrow the overlapped area.
- To use as the IF Shift function, set "PBT1" and "PBT2" to the same value.
- The PBT is adjustable in 50 Hz steps in the SSB, CW, and RTTY modes, and 200 Hz in the AM mode. The center shift value changes in 25 Hz steps in the SSB, CW, and RTTY modes, and 100 Hz in the AM mode.

**NOTE:** While rotating **(TWIN PBT)**, you may hear some noise. This comes from the FPGA and does not indicate an equipment malfunction.

### ① Information

- A dot "." is displayed on the IF Filter Indicator when you change the IF passband width, using the Digital Twin PBT.

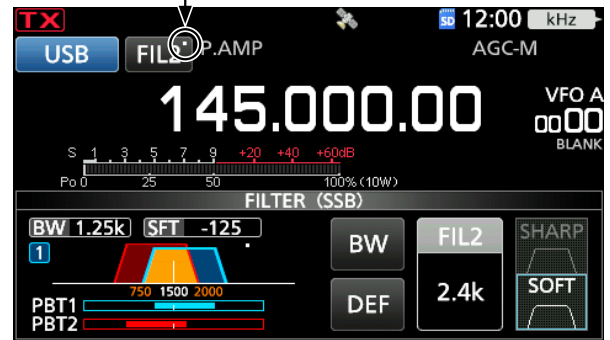

- Touch the filter icon for 1 second to display the current passband width and shift value. Opens the FILTER screen.

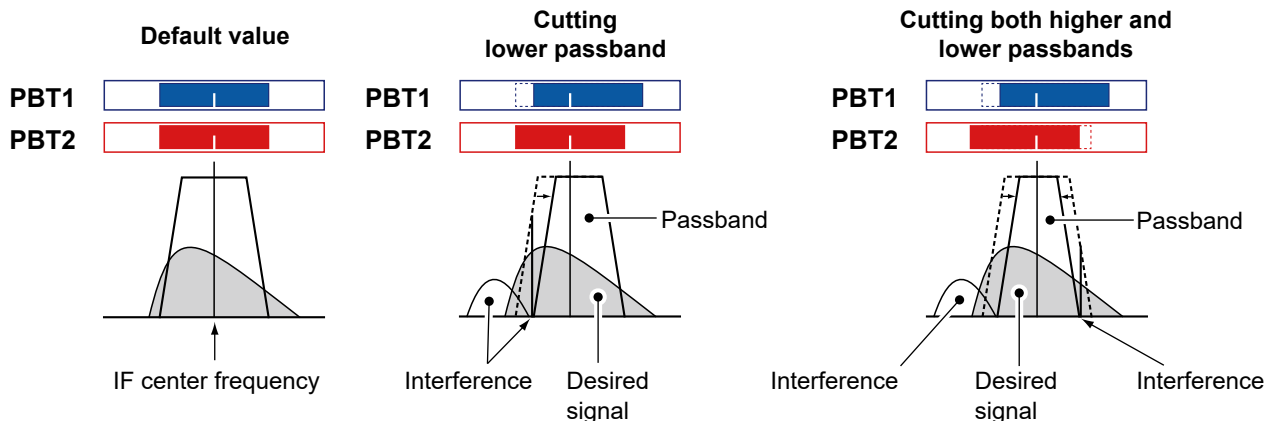
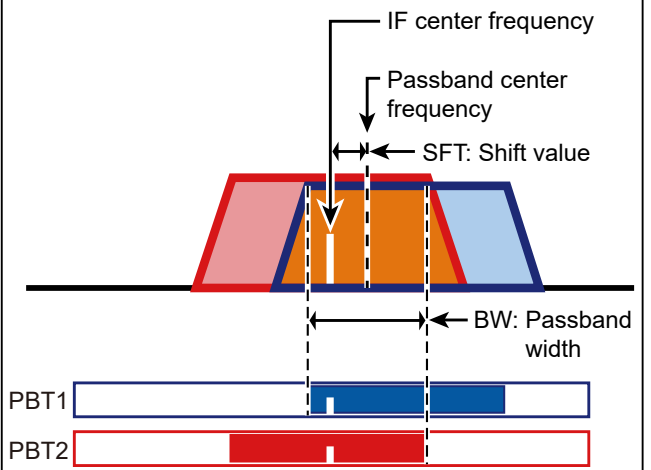
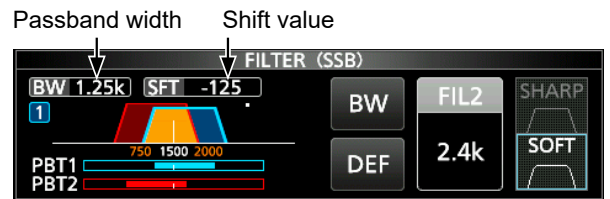

## Selecting the IF filter

### SSB, CW, RTTY, and AM modes

The IC-905 has 3 IF filter passband widths for each mode, and you can select them on the FILTER screen.

You can set the IF filter to wide (FIL 1), mid (FIL 2), or narrow (FIL 3).

1. Select the operating mode. (Example: USB)
2. Touch the filter icon for 1 second.

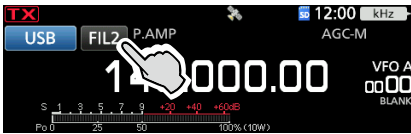

- Opens the FILTER (SSB) screen.

3. Touch the filter icon several times to select FIL 1 (wide), FIL 2 (mid), or FIL 3 (narrow).
4. Touch [BW].

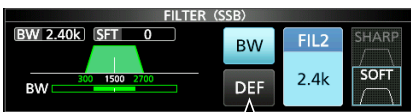

You can reset to the default settings by touching this key for 1 second.

- Selects the passband width mode.
5. Rotate **(MAIN DIAL)** to select the passband width.
    - ① You cannot change the passband width in the FM, FM-D, or DV mode.
    - ① When you change the passband width, the Digital Twin PBT setting value is reset to the center position.
    - ① "BPF" is displayed when a band width less than 500 Hz is selected in the SSB, CW, or RTTY mode.
  6. To close the FILTER screen, push **(EXIT)**.

### TIP:

- When you set the IF filter to FIL2 or FIL3 in the FM mode, the transceiver will transmit in the FM narrow mode.
- When you set the IF filter to FIL2 or FIL3 in the ATV mode, the transmit filter width will narrow.

Mode	IF filter	Selectable range (steps)
SSB	FIL 1 (3.0 kHz)	50 Hz to 500 Hz (50 Hz)/ 600 Hz to 3.6 kHz (100 Hz)
	FIL 2 (2.4 kHz)	
	FIL 3 (1.8 kHz)	
SSB-D	FIL 1 (3.0 kHz)	50 Hz to 500 Hz (50 Hz)/ 600 Hz to 3.6 kHz (100 Hz)
	FIL 2 (1.2 kHz)	
	FIL 3 (500 Hz)	
CW	FIL 1 (1.2 kHz)	50 Hz to 500 Hz (50 Hz)/ 600 Hz to 3.6 kHz (100 Hz)
	FIL 2 (500 Hz)	
	FIL 3 (250 Hz)	
RTTY	FIL 1 (2.4 kHz)	50 Hz to 500 Hz (50 Hz) 600 Hz to 2.7 kHz (100 Hz)
	FIL 2 (500 Hz)	
	FIL 3 (250 Hz)	
AM AM-D	FIL 1 (9.0 kHz)	200 Hz to 10.0 kHz (200 Hz)
	FIL 2 (6.0 kHz)	
	FIL 3 (3.0 kHz)	
FM FM-D DV	FIL 1 (15 kHz)	Fixed
	FIL 2 (10 kHz)	
	FIL 3 (7.0 kHz)	
DD	FIL 1 (150 kHz)	Fixed
ATV	FIL 1 (17 MHz)	Fixed
	FIL 2 (10 MHz)	
	FIL 3 (5 MHz)	

## Selecting the IF filter shape

### SSB and CW modes

You can set the IF filter shape for each mode.

1. Select the operating mode. (Example: USB)
2. Touch the filter icon for 1 second.
  - Opens the FILTER (SSB) screen.
3. Touch [SHARP] or [SOFT].

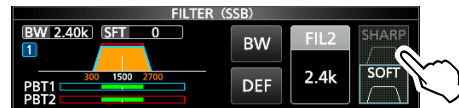

4. To close the FILTER screen, push **(EXIT)**.

### SHARP

This selection is to emphasize the passband width of the filter. The filter has an almost ideal shape factor. Signals that are out of the passband are extremely filtered out, and it gives you better audio quality.

### SOFT

The filter shoulders are roundly formed as in analog filters. This decreases noise components in the high and low frequencies of the filter passband, and increases the S/N of the target signal. These characteristics play an effective role in picking up very weak signals. The shape factor is retained, and the sharpness of the bandpass is excellent.



## Notch Filter

### SSB, CW, RTTY, AM, and FM modes

The IC-905 has Auto Notch and Manual Notch functions.

Auto Notch automatically attenuates beat tones, tuning signals, and so on. It can be used in the SSB, AM, and FM modes.

Manual Notch attenuates beat tones, tuning signals, and so on by manually adjusting the filtering frequency. It can be used in the SSB, CW, RTTY, and AM modes.

### ◇ Selecting the Notch filter type

1. Push **[FUNCTION]**.
  - Opens the FUNCTION screen.
2. Touch **[NOTCH]**.



① Touching **[NOTCH]** changes between “AN (Auto Notch),” “MN (Manual Notch),” and OFF.

3. To close the FUNCTION screen, push **[EXIT]**.



Displayed when Auto Notch is selected.

### ◇ Setting the Manual Notch filter

When Manual Notch is selected, adjust the filtered frequency.

1. Push **[FUNCTION]**.
  - Opens the FUNCTION screen.
2. Touch **[NOTCH]** for 1 second.

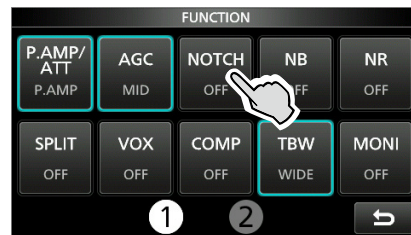

- Opens the NOTCH menu.
- The Manual Notch is automatically selected, and “MN” is displayed.

3. Touch **[WIDTH]** several times to select the Manual Notch filter width from “WIDE,” “MID,” and “NAR.”

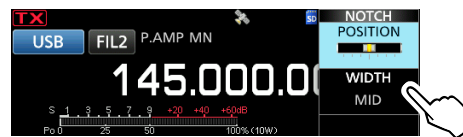

4. Rotate **[MULTI]** slowly, to manually attenuate the frequency.
5. To close the NOTCH menu, push **[EXIT]**.

**NOTE:** While adjusting, noise may be heard. This comes from the FPGA and does not indicate an equipment malfunction.

## Noise Blanker

### SSB, CW, RTTY, and AM modes

The Noise Blanker eliminates pulse-type noise, such as the noise from car ignitions.

1. Push **[FUNCTION]**.
  - Opens the FUNCTION screen.
2. Touch **[NB]**.



① Touching **[NB]** turns this function ON or OFF.

3. To close the FUNCTION screen, push **[EXIT]**.



Displayed when the Noise Blanker is ON.

**NOTE:** When using the Noise Blanker, received signals may be distorted if they are excessively strong, or the noise is other than a pulse type. In that case, turn OFF the Noise Blanker, or shallow the DEPTH on the NB menu. See the description below for details.

### Adjusting the NB level and time

To deal with various types of noise, you can adjust the attenuation level and blanking depth and width in the NB menu.

1. Push **[FUNCTION]**.
  - Opens the FUNCTION screen.
2. Touch **[NB]** for 1 second.



• Turns ON the Noise Blanker and opens the NB menu.

3. Touch the item to adjust. (Example: DEPTH)

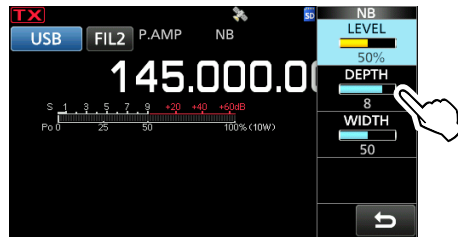

4. Rotate **[MULTI]** to adjust the item. (Example: 8)
5. To close the NB menu, push **[MULTI]**.

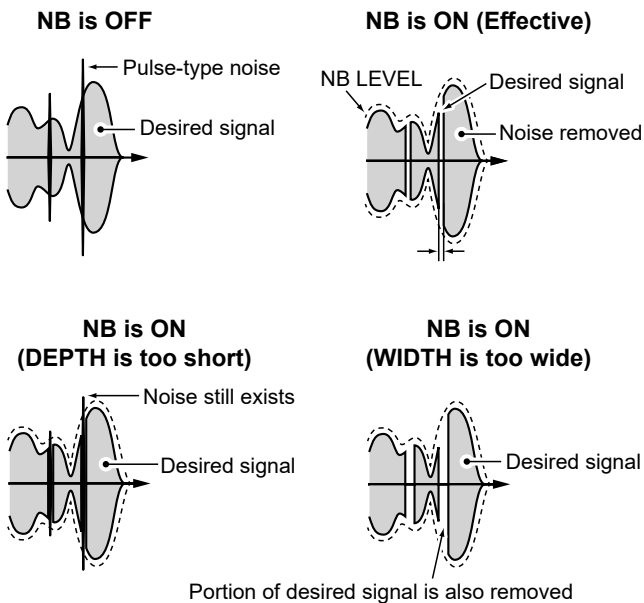

Portion of desired signal is also removed

**LEVEL** \_\_\_\_\_ (Default: 50%)

Adjusts the level where the Noise Blanker activates between 0 and 100%.

**DEPTH** \_\_\_\_\_ (Default: 8)

Adjusts the noise attenuation level to between 1 and 10.

**WIDTH** \_\_\_\_\_ (Default: 50)

Adjusts the blanking duration time to between 1 and 100.

## Noise Reduction

### SSB, CW, RTTY, AM, FM, DV, and ATV modes

The Noise Reduction function reduces random noise components and enhances signal audio.

1. Push **[FUNCTION]**.
  - Opens the FUNCTION screen.
2. Touch **[NR]**.



- ① Touching **[NR]** turns this function ON or OFF.
3. To close the FUNCTION screen, push **[EXIT]**.



### ◇ Adjusting the Noise Reduction level

Adjust the Noise Reduction level to where noise is reduced but the received signal is not distorted.

1. Push **[FUNCTION]**.
  - Opens the FUNCTION screen.
2. Touch **[NR]** for 1 second.
  - Turns ON the Noise Reduction function and opens the NR menu.
3. Rotate **[MULTI]** to adjust the Noise Reduction level to between 0 and 15.

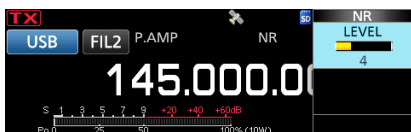

- ① Adjust to a higher level to increase the reduction level, and a lower level to decrease it.
4. To close the NR menu, push **[MULTI]**.

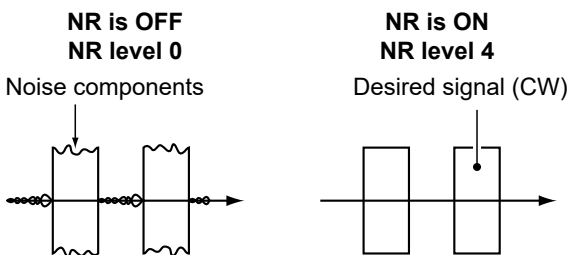

## Setting the transmit filter width

### SSB mode

The transmit filter width for the SSB and SSB-D modes can be set. WIDE (wide), MID (mid), or NAR (narrow) can be selected only in the SSB mode.

- ① The filter settings are memorized for both the ON and OFF states of the Compressor function.

### To change the filter width in the SSB mode:

1. Set the operating mode to USB or LSB.
2. Push **[FUNCTION]**.
  - Opens the FUNCTION screen.
3. Touch **[TBW]**.

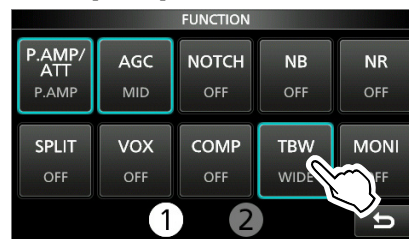

- ① Touching **[TBW]** sets the filter width to WIDE, MID, or NAR.

The transmit filter widths are set to the following values by default.

- SSB (WIDE): 100 Hz to 2900 Hz
- SSB (MID): 300 Hz to 2700 Hz
- SSB (NAR): 500 Hz to 2500 Hz
- SSB-D: 300 Hz to 2700 Hz

- ① You can change the filter width values in the following settings.

<b>[MENU]</b> »	SET > Tone Control/TBW > TX > SSB > <b>TBW (WIDE)</b>
<b>[MENU]</b> »	SET > Tone Control/TBW > TX > SSB > <b>TBW (MID)</b>
<b>[MENU]</b> »	SET > Tone Control/TBW > TX > SSB > <b>TBW (NAR)</b>
<b>[MENU]</b> »	SET > Tone Control/TBW > TX > SSB-D > <b>TBW</b>

## Setting the Speech Compressor

### SSB mode

The Speech Compressor increases the average RF output power, improving readability at the receiving station. This function compresses the transmitter audio input to increase the average audio output level.

① The function is effective for long-distance communication, or when propagation conditions are poor.

### ◇ Setting before using the Speech Compressor function

1. Select the SSB mode. (Example: USB)
2. Push **[FUNCTION]**.
  - Opens the FUNCTION screen.
3. Be sure the Speech Compressor is OFF.
  - ① If it is ON, touch [COMP] to turn it OFF.



4. Push **[EXIT]** to close the FUNCTION screen.
5. Touch the Multi-function meter until the ALC meter is displayed.
  - ① Touching the Multi-function meter sets the meter to Po, SWR, ALC, COMP, Vd, or Id.

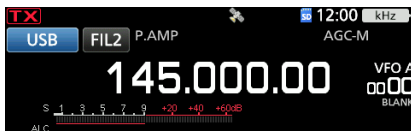

6. Push **[MULTI]** to open the Multi-function menu.
7. Touch **[MIC GAIN]**, and then rotate **[MULTI]** to adjust it by speaking into the microphone to where the ALC meter reads within the 30 to 50% range of the ALC zone.

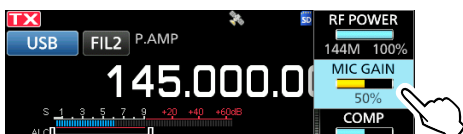

### ◇ Using the Speech Compressor function

1. Touch the Multi-function meter again to display the COMP meter.
2. Push **[FUNCTION]**.
  - Opens the FUNCTION screen.
3. Touch **[COMP]** for 1 second.



- Turns ON the Speech Compressor function and opens the Multi-function menu.
4. While speaking into the microphone at your normal voice level, rotate **[MULTI]** to adjust the Speech Compressor level to where the COMP meter reads within the COMP zone (10 to 20 dB range).
    - ① If the COMP meter peaks exceed the COMP zone, your transmitted voice may be distorted.

Speech Compressor is ON

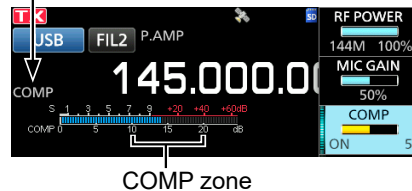



5. To close the Multi-function menu, push **[MULTI]**.

## Split frequency operation

Split frequency operation enables you to transmit and receive on different frequencies in the same band.

There are 2 ways to use Split frequency operation.

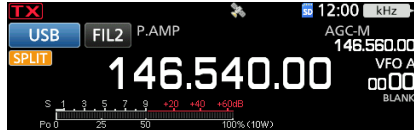
- Use the Quick Split function.
- Use the receive and transmit frequencies set to VFO A and VFO B.

The other station		Your station	
Transmit frequency	USB mode 146.540 MHz	VFO A Receive frequency	
Receive frequency	USB mode 146.560 MHz	VFO B Transmit frequency	

### ◇ Using the Quick Split function

The Quick Split function enables you to automatically equalize the frequency and mode of the VFOs to the displayed VFO, and activate the Split function.

1. Set VFO A's receive frequency and operating mode. (Example: 146.540 MHz in the USB mode)
2. Push **[FUNCTION]**.
  - Opens the FUNCTION screen.
3. Touch **[SPLIT]** for 1 second.

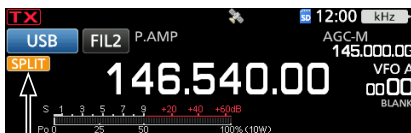

Displayed

- The Quick Split function is turned ON, and the VFO A settings are set to VFO B.

4. While holding down **[XFC]**, set the operating frequency offset between transmit and receive. (Example: 20.00 kHz)



The offset between transmit and receive while holding down **[XFC]**.

### ◇ Using the receive and transmit frequencies set to VFO A and VFO B

1. Set VFO A's receive frequency and operating mode. (Example: 146.540 MHz in the USB mode)

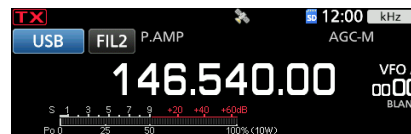

2. Select VFO B, and then set the receive frequency and the operating mode. (Example: 146.560 MHz in the USB mode)

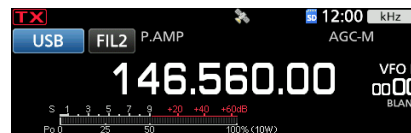

3. Push **[FUNCTION]**.
  - Opens the FUNCTION screen.
4. Touch **[SPLIT]** to turn ON the Split function.
  - ① Touching **[SPLIT]** turns the Split function ON or OFF.
5. To close the FUNCTION screen, push **[EXIT]**.

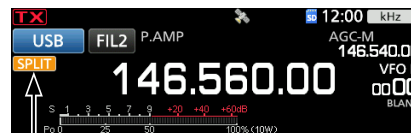

Displayed

6. Return to VFO A.

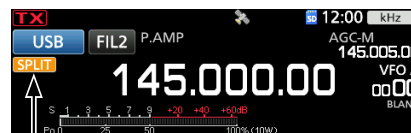

Displayed

- ① The Split frequency operation is ready.

## Split Lock function

To prevent accidentally changing the receive frequency by releasing **[XFC]** while rotating **[MAIN DIAL]**, use the Split Lock function. Using both this function and the Dial Lock function enables you to change only the transmit frequency.

1. Turn ON the Split Lock function.  
**[MENU]** » **SET > Function > SPLIT > SPLIT LOCK**
2. Turn ON the Split function.
3. Hold down **[SPEECH]** for 1 second to turn ON the Dial Lock function.
4. While holding down **[XFC]**, set the transmit frequency.

## Operating CW

### ◇ Setting the CW pitch control

You can set the received CW audio pitch and the CW side tone to suit your preference, without changing the operating frequency.

1. Select the CW mode.
2. Push **[MULTI]** to open the Multi-function menu.
3. Touch **[CW PITCH]**.

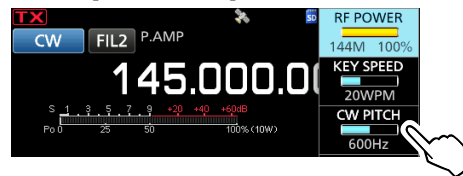

4. Rotate **[MULTI]** to set the CW pitch to between 300 and 900 Hz (in 5 Hz steps).
5. To close the Multi-function menu, push **[MULTI]**.

### ◇ Setting the key speed

You can set the keying speed of the internal electronic keyer.

1. Select the CW mode.
2. Push **[MULTI]** to open the Multi-function menu.
3. Touch **[KEY SPEED]**.

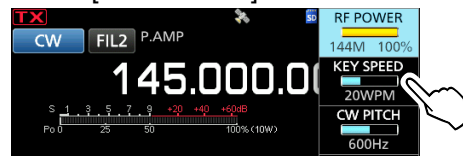

4. Rotate **[MULTI]** to set the key speed to between 6 and 48 Words Per Minute (WPM).
5. To close the Multi-function menu, push **[MULTI]**.

## Operating CW

## ◇ Using the Break-in function

Use the Break-in function in the CW mode to automatically switch between transmit and receive when keying. The IC-905 is capable of operating in the Semi Break-in and Full break-in modes.

**TIP:** “Key Type” is set to “Paddle” by default. You can select the keyer type in the following item.

**MENU** » **KEYER > EDIT/SET > CW-KEY SET > Key Type**

## Semi Break-in operation

In the Semi Break-in mode, the transceiver transmits when keying, and then automatically returns to receive after a preset time after you stop keying.

1. Select the CW mode.
2. Push **BK-IN** several times to select “BKIN.”  
① Pushing **BK-IN** selects “BKIN (Semi Break-in),” “F-BKIN (Full Break-in),” or OFF (no indication).

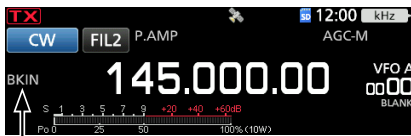

The selected mode (Semi Break-in) is displayed.

3. To adjust the Break-in delay time, hold down **BK-IN** for 1 second.
  - Opens the BKIN menu.
4. Rotate **MULTI** to set to where the transceiver returns to receive after the desired delay time after you stop keying.

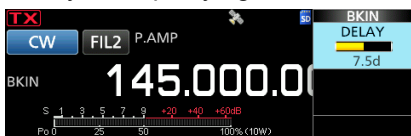

- ① When using a paddle, push **MULTI** to open the Multi-function menu, and then adjust the KEY SPEED (p. 4-12) while operating the paddle.
5. To close the BKIN menu, push **EXIT**.

## Full Break-in operation

In the Full Break-in mode, the transceiver automatically transmits while keying down, and then immediately returns to receive after keying up.

1. Select the CW mode.
2. Push **BK-IN** several times to display “F-BKIN.”  
① Pushing **BK-IN** selects “BKIN (Semi Break-in),” “F-BKIN (Full Break-in),” or OFF (no indication).

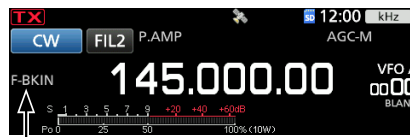

The selected mode (Full Break-in) is displayed.

3. Use a straight key or paddle.  
① In the Full break-in mode, the transceiver automatically returns to receive immediately after you key up. The transceiver receives while keying up.

## ◇ Monitoring the CW side tone

When the transceiver is in standby and the Break-In function is OFF, you can listen to the CW side tone without actually transmitting.

## ① Information

- This enables you to match your transmit frequency exactly to another station's by matching the audio tone.
- You can also use the CW side tone (make sure the Break-in function is OFF) to practice CW sending.
- You can adjust the CW side tone level in the following item.

**MENU** » **KEYER > EDIT/SET > CW-KEY SET > Side Tone Level**

## 4 RECEIVING AND TRANSMITTING

### Operating CW

#### ◇ About the electronic Keyer function

You can set the Memory Keyer function settings, paddle polarity settings, and so on of the Electronic Keyer.

1. Select the CW mode.
2. Open the KEYSER screen.

**MENU** » **KEYER**

3. Touch [EDIT/SET].



- Opens the EDIT/SET screen.

4. Select the desired item to set.

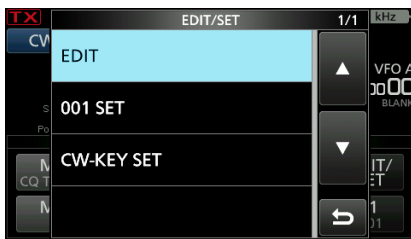

5. To close the KEYSER screen, push **EXIT** several times.

EDIT

#### KEYER MEMORY edit menu

You can edit the Keyer memories M1 to M8.

001 SET

#### KEYER 001 Contest Number menu

You can set the following items.

- Number Style
- Count Up Trigger
- Present Number

CW-KEY SET

#### CW-KEY SET menu

You can set the following items.

- Side Tone Level
- Side Tone Level Limit
- Keyer Repeat Time
- Dot/Dash Ratio
- Rise Time
- Paddle Polarity
- Key Type
- MIC Up/Down Keyer

## Auto Tuning function

### CW mode

You can tune in a CW signal you are receiving using the Auto Tuning function. You can automatically tune by pushing **AUTOTUNE (RX-CS)**. This function is active only in the CW mode.

- ① While using the RIT function, the RIT frequency is automatically tuned by this function.

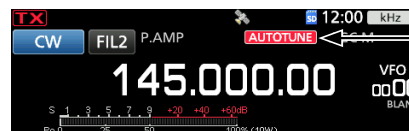

Displayed while tuning

**NOTE:** When receiving a weak signal, or receiving a signal with interference, the Auto Tuning function may tune the receiver to an undesired signal, or may not start to tune. In such case, a warning beep sounds.

- ① The Auto Tuning function tunes the frequency in the IF bandwidth.



## Spectrum scope screen

The spectrum scope enables you to display the activity on the selected band, as well as the relative strengths of various signals in that band.

The transceiver has three spectrum scope modes, the Center mode, the Fixed mode, and the Scroll mode. You can also turn the Waterfall display ON or OFF. In addition, you can select the Mini scope to display the scope in a smaller size on the screen.

### • Center mode screen

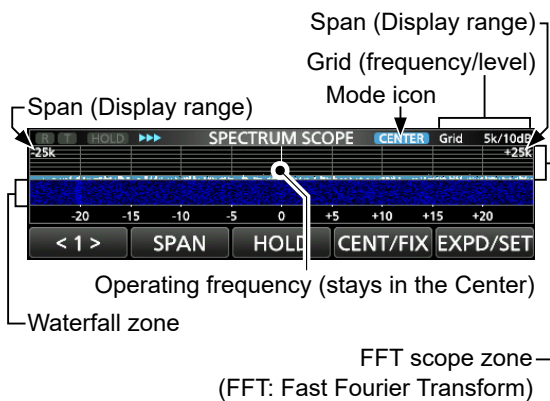

### • Fixed mode screen

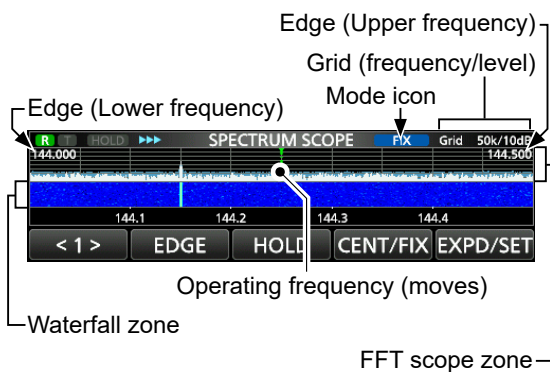

### • Scroll mode screen

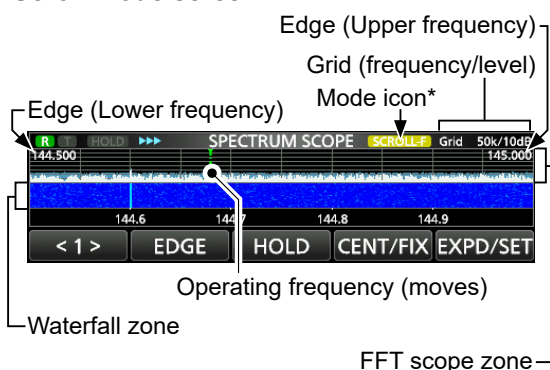

\* When in the SCROLL-C mode, **SCROLL-C** is displayed.

### ◇ Using the Spectrum Scope

Display the SPECTRUM SCOPE screen.

**MENU** » **SCOPE**

MENU 1: Center/Scroll-C mode

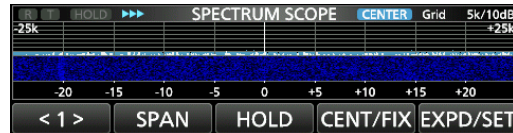

MENU 1: Fix/Scroll-F mode



MENU 2: Center/Fix/Scroll-C/Scroll-F mode



Key	Action	
< 1 > / < 2 >	Selects the Function menus.	
SPAN	Touch	In the Center mode and the Scroll-C mode, opens the scope span window. ① Touch [+] or [-] to select the scope span. ① Touch [SPAN] again to close the window.
	Touch for 1 second	Resets to the $\pm 2.5$ kHz span.
EDGE	In the Fixed mode and the Scroll-F mode, selects the Edge frequencies. ① You can set the upper and lower Edge frequencies in "Fixed Edges" on the SCOPE SET screen by touching [EXPD/SET] for 1 second.	
HOLD	Touch	Turns the Hold function ON or OFF. • [HOLD] and the Marker are displayed. Freezes the current spectrum.
	Touch for 1 second	Clears the Peak Hold level.
CENT/FIX	Touch	Selects the Center or Fixed mode.
	Touch for 1 second	Selects the Scroll mode.
EXPD/SET	Touch	Selects the Expanded or Normal screen.
	Touch for 1 second	Displays the SCOPE SET screen. ① See the Advanced manual for details.
REF	Opens the "REF Level" window. ① Rotate <b>MAIN DIAL</b> to adjust the Reference level. ① Touch again to close the window.	
SPEED	Selects the sweep speed. • "▶▶▶" (FAST), "▶▶" (MID), or "▶" (SLOW).	
MARKER	Selects the Marker.	

## 5 SCOPE OPERATION

### Spectrum scope screen

#### ◇ Center mode

Displays signals around the operating frequency within the selected span. The operating frequency is always displayed in the center of the screen.

1. Display the SPECTRUM SCOPE screen.  
**MENU** » **SCOPE**
2. Touch [CENT/FIX] to select the Center mode.  
 ⓘ Touch [CENT/FIX] to toggle between the Center and Fixed modes.
3. Touch [SPAN] to open the scope span window.
4. Touch [+] or [-] to select the scope span.
  - $\pm 2.5$  kHz,  $\pm 5.0$  kHz,  $\pm 10$  kHz,  $\pm 25$  kHz,  $\pm 50$  kHz,  $\pm 100$  kHz,  $\pm 250$  kHz,  $\pm 500$  kHz,  $\pm 1.0$  MHz,  $\pm 2.5$  MHz,  $\pm 5.0$  MHz,  $\pm 10$  MHz,  $\pm 25$  MHz
  - ⓘ Touch [SPAN] again to close the window.
  - ⓘ Touch [+] for 1 second to select the  $\pm 25$  MHz span (maximum), and Touch [-] for 1 second to select the  $\pm 2.5$  kHz span (minimum).

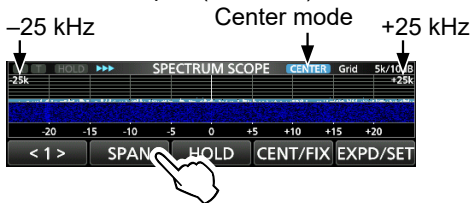

#### ◇ Fixed mode

Displays signals within a specified frequency range. The selected frequency band activity can easily be observed in this mode.

Four Fixed Edge bands can be set for each amateur frequency band covered by the transceiver in the SCOPE SET screen.

1. Display the SPECTRUM SCOPE screen.  
**MENU** » **SCOPE**
2. Touch [CENT/FIX] to select the Fixed mode.  
 ⓘ Touch [CENT/FIX] to toggle between the Center and Fixed modes.
3. Touch [EDGE] several times to select the Edge frequency.
  - ⓘ When the operating frequency moves outside the lower or upper Edge frequency, "<<" or ">>" is displayed in the upper side corners of the SPECTRUM SCOPE screen.
    - <<: The frequency is outside the lower edge.
    - >>: The frequency is outside the higher edge.
  - When the frequency goes further away, "Scope Out of Range" is displayed.

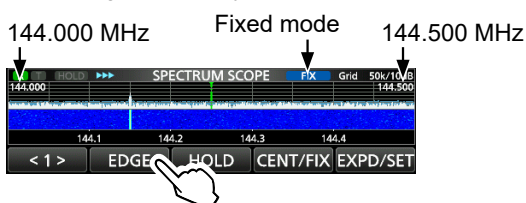

#### ◇ Scroll mode

Displays signals within a selected span. When the operating frequency moves outside of the screen, the displayed frequency range is automatically scrolled.

1. Display the SPECTRUM SCOPE screen.  
**MENU** » **SCOPE**
2. Touch [CENT/FIX] for 1 second to select the Scroll mode.
  - When changing the Center mode to the Scroll mode, "SCROLL-C" is displayed. You can change the scope span by touching [SPAN].
  - When changing the Fixed mode to the Scroll mode, "SCROLL-F" is displayed. You can change the Edge frequencies by touching [EDGE].
3. Touch [CENT/FIX] to return to the previous mode.
  - When returning to the Center mode, the scope span does not return to the previous setting.
  - When returning to the Fixed mode, the Edge frequencies return to the last selected "Fixed Edges." If the operating frequency is below the lower Edge frequency, "<<" or ">>" is displayed in the upper side corners of the SPECTRUM SCOPE screen.

#### ◇ Marker

The Marker displays the operating frequency in the SPECTRUM SCOPE screen.

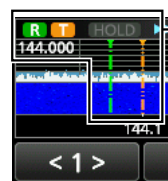

- R:** The RX marker
  - Marks the receive frequency.
- T:** The TX marker
  - Marks the transmit frequency.

#### • About RX Marker

In the Fixed mode and the Scroll mode, the RX Marker displays the operating frequency within a specified frequency range. So, the transceiver always displays the RX marker in the Scope screen.

In the Center mode, the operating frequency stays in the center of the screen. Thus, the transceiver does not display the RX Marker.

- ⓘ When the Hold function is ON, the RX Marker is displayed to indicate the operating frequency's location.

Spectrum scope screen

◇ Touch screen operation

By touching the FFT scope zone or the waterfall zone in the SPECTRUM SCOPE screen, the area will be zoomed in. Then you touch the signal in the zoomed area, you can directly tune your frequency to the signal.

① Holding down **XFC** changes the transmit frequency.

1. Display the SPECTRUM SCOPE screen.

**MENU** » **SCOPE**

2. Touch the Scope screen.

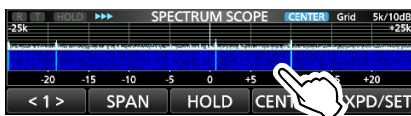

- The area around the touched point is zoomed in.

3. Touch the signal in the zoomed area.

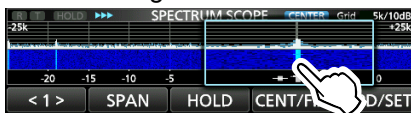

① Information

- In the Center mode, the operating frequency changes to the touched point, and the point moves to the screen center.
- In the Fixed mode, the operating frequency and marker change to the touched point.
- Touch out of the zoomed area to close the zoomed window.

◇ Mini scope screen

The Mini scope screen can be simultaneously displayed with another function displays, such as the RTTY DECODE screen and the AUDIO SCOPE screen.

Push **M.SCOPE** to turn the Mini scope screen ON or OFF.

① Hold down **M.SCOPE** for 1 second to display the SPECTRUM SCOPE screen.

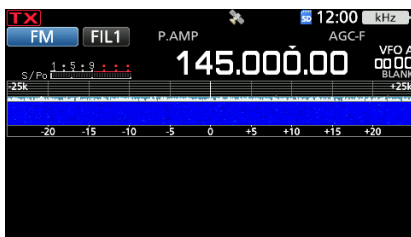

Audio scope screen

This audio scope enables you to display the received signal's frequency component on the FFT scope, and its waveform components on the Oscilloscope. The FFT scope also has a waterfall.

Display the AUDIO SCOPE screen.

**MENU** » **AUDIO**

• AUDIO SCOPE screen

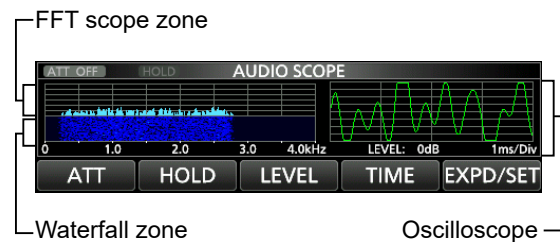

Key	Action	
ATT	Touch	Selects the attenuator for the FFT scope. • 0 (OFF), 10, 20, or 30 dB
	Touch for 1 second	Turns OFF the attenuator. (0 dB)
HOLD	Turns the Hold function ON or OFF. • <b>HOLD</b> is displayed and freezes the current audio spectrum.	
LEVEL	Selects the Oscilloscope level. • 0, -10, -20, or -30 dB	
TIME	Selects the Oscilloscope sweep time. • 1, 3, 10, 30, 100, or 300 ms/Div	
EXPD/SET	Touch	Selects the Expanded or Normal screen.
	Touch for 1 second	Displays the AUDIO SCOPE SET screen. ① See the Advanced manual for details.

The SD cards and SDHC cards are user supplied.

**TIP:** Icom recommends that you save the transceiver's factory default data for backup.

## About the SD cards

You can use an SD card of up to 2 GB, or an SDHC of up to 32 GB. Icom has checked the compatibility of the following cards.

(As of February 2023)

Brand	Type	Memory size
SanDisk®	SD	2 GB
	SDHC	4/8/16/32 GB

- ① The above list does not guarantee the card's performance.
- ① Throughout the rest of this document, the SD cards and SDHC cards are simply called the SD card or the card.

### NOTE:

- Before using the SD card, thoroughly read their instructions.
- If any of the following occur, the card's data may be corrupted or deleted.
  - You remove the card from the transceiver while it is still accessing the card.
  - A power failure occurs, or the power cable is disconnected, while accessing the card.
  - You drop, impact, or vibrate the card.
- Do not touch the contacts of the card.
- The transceiver may take a longer time to recognize a high capacity card.
- The card has a certain lifetime, so data reading or writing may not be possible after using it for a long period of time. In that case, use a new one. We recommend you to make a backup of the data onto another device.
- Icom will not be responsible for any damage caused by data corruption on a card.

## Saving data

You can save the following data onto the card.

- The transceiver's settings
- Communication/receive log and contents
- Automatic answering voice audio in the DV mode
- Voice audio for the Voice TX function
- RTTY decode log
- Captured screens
- Memory channel contents
- Your (UR) call sign memory
- Repeater List
- GPS memory
- Position data from the GPS receiver
- Pictures for the Share Pictures function
- Transmitted and received log of Share Picture

## Inserting

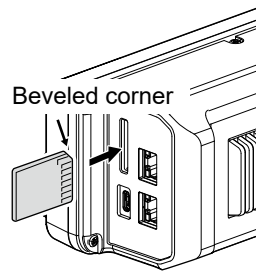

Insert the SD card as shown to the left.

- ① Insert the SD card into the slot until it locks in place, and makes a 'click' sound.
- ① Be sure to check the card orientation before inserting.

### NOTE:

**Before using an SD card for the first time, format it in the transceiver.**

- Formatting a card erases all its data. Before formatting any used card, back up its data onto another device.
- After inserting or formatting, a special folder on the card that you need for operations like updating the firmware is created on the card.

**IMPORTANT:** Even if you have formatted an SD card, some data may remain in the card. When you dispose the card, be sure to physically destroy it to avoid unauthorized access to any data that remains.

## Formatting

Before using an SD card, format it to be used with the transceiver by doing the following steps.

1. Open the SD CARD screen.

**[MENU]** » **[SET > SD Card]**

2. Touch "Format."

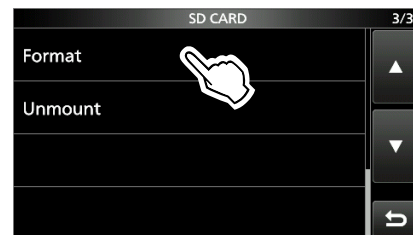

3. Touch [YES] to start formatting.

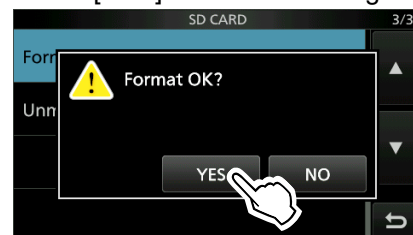

- After formatting, returns to the SD CARD screen.

- ① To cancel formatting, touch [NO].
4. To close the SD CARD screen, push **[EXIT]** several times.

## Saving the setting data

The Memory channels and the transceiver's settings can be saved onto an SD card.

1. Open the SAVE SETTING screen.

**MENU** » **SET > SD Card > Save Setting**

2. Touch “<<New File>>.”



① The file name is automatically set in the following format: Setyyyyymmdd\_xx (yyyy: Year, mm: month, dd: day, xx: serial number).

3. To save the file with the displayed name, touch [ENT].

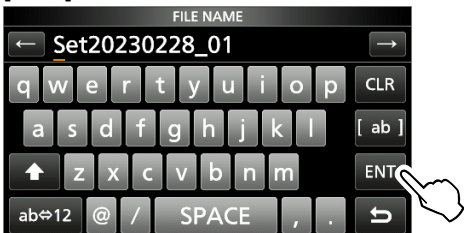

① If you want to change the name, delete the name and reenter it, and then touch [ENT].

4. Touch [YES].

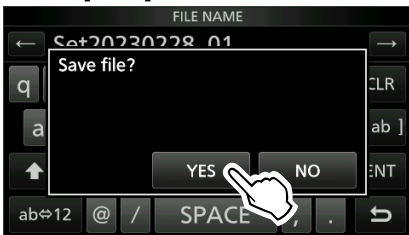

• Saves the data settings.

5. To close the SD CARD screen, push **EXIT** several times.

## Unmounting

Before you remove a card when the transceiver is ON, be sure to electrically unmount it, as shown below. Otherwise, the data may be corrupted or deleted.

1. Open the SD CARD screen.

**MENU** » **SET > SD Card**

2. Touch “Unmount.”

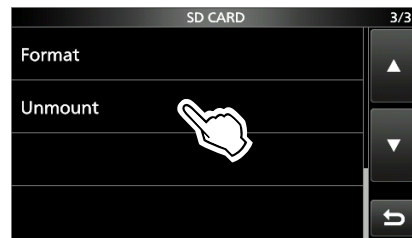

3. Touch [YES] to unmount.

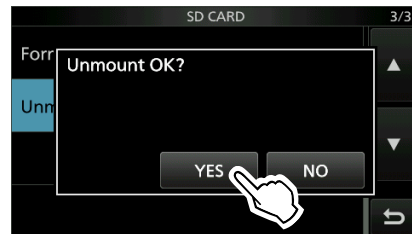

• After unmounting, returns to the SD CARD screen.  
① To cancel unmounting, touch [NO].

4. Remove the card from the transceiver.

• Push in the card until a 'click' sounds to unlock the card, and then pull it out.

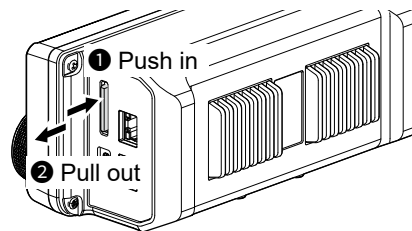

5. To close the SD CARD screen, push **EXIT** several times.

### When the transceiver is OFF

You can remove the card starting from step 4 of the steps described above.

**NOTE:** The built-in GPS receiver cannot calculate its position if it cannot receive signals from the GPS satellites. Refer to page iv for details.

## Confirming the GPS signal receiving

The transceiver has a built-in GPS receiver. You can check your current location, and transmit GPS data in the DV mode. See the Advanced Manual for details.

Confirm the GPS receiver is receiving satellite data.

The GPS icon blinks when searching for satellites.

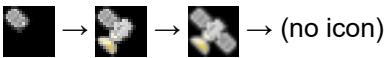

The GPS icon stops blinking when the minimum needed number of satellites are found.



① It may take only a few seconds to receive, or it may take a few minutes, depending on your operating environment.

① Even when "Position Input" is set to "Manual," the icon is displayed.

**MENU** » **GPS > GPS Set > Position Input**

① The IC-905 automatically adjusts the internal reference frequency using the received GPS data as the default setting.

**MENU** » **SET > Function > REF Adjust**

**NOTE:** If you cannot receive GPS data, manually set the date and time. (p. 9-1)

## Checking your location

You can check your current location.

① If you transmit while displaying the GPS POSITION screen, the screen closes.

1. Push **QUICK**.
2. Touch "GPS Position."



• Opens the GPS POSITION screen.

3. Rotate **MAIN DIAL**.

• Changes between the MY (My position), RX (Received position), MEM (GPS Memory position), or ALM (GPS Alarm position) screen.

4. To close the GPS POSITION screen, push **EXIT**.

### GPS POSITION (MY) screen

Your course heading

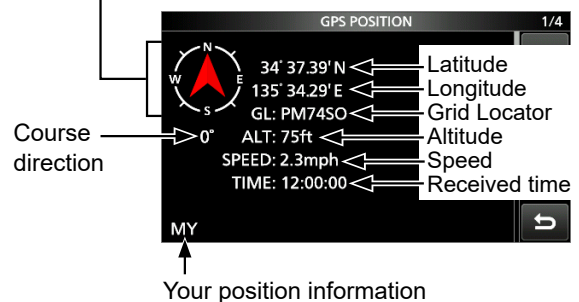

Your position information

① When "Position Input" is set to "Manual," SPEED, Compass, and Compass Direction are not displayed.

## Set mode description

You can use the Set mode to set infrequently changed values or function settings.

**TIP:** The Set mode is constructed in a tree structure. You can go to the next tree level, or go back a level, depending on the selected item.

1. Push **MENU**.

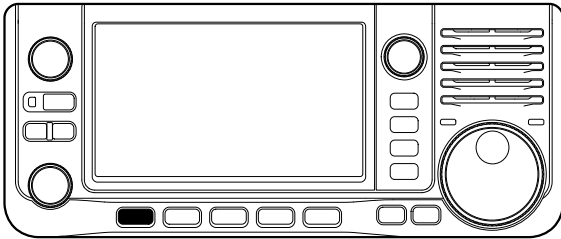

2. Touch **[SET]**.



3. Touch **[▲]** or **[▼]** to scroll through the items.

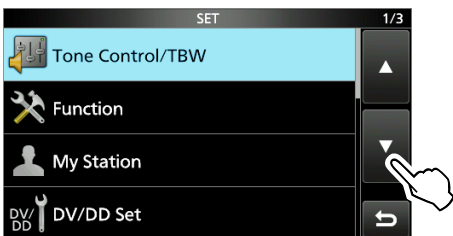

① You can also rotate **MULTI** to scroll through the items.

4. Touch the item to open its setting screen, or to open its next tree level.

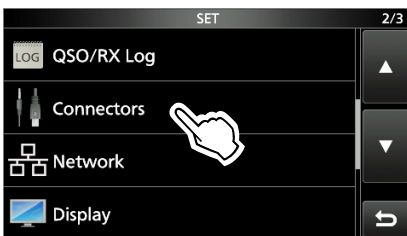

5. Repeat steps 3 and 4 to open the desired item's setting screen.

① To go back a tree level, push **EXIT**.

6. Touch to select or to set the option.

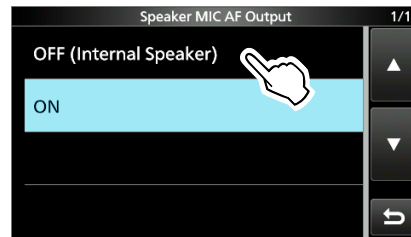

- The selected option is saved, and returns to the previous screen.

7. To close the SET screen, push **EXIT** several times.

**TIP: Resetting to the default setting**

1. Push **QUICK** to display the QUICK MENU screen.
2. Touch "Default" to reset to the default setting.  
① To close the QUICK MENU screen, push **EXIT**.

**NOTE:** The default settings shown below are for the USA transceiver version. The default settings may differ, depending on your transceiver version.

## Tone Control/TBW

**MENU** » **SET > Tone Control/TBW > RX**

### SSB, AM, FM, DV, CW, RTTY

**RX HPF/LPF** (Default: - - - - -)

Sets the cut-off frequencies for the receive audio high-pass filter and low-pass filter, in 100 Hz steps.

① If this item is set, the “RX Bass” and “RX Treble” items are automatically set to “0.”

### SSB, AM, FM, DV, ATV

**RX Bass** (Default: 0)

**RX Treble** (Default: 0)

Sets the bass or treble level of the receive audio.

**MENU** » **SET > Tone Control/TBW > TX**

### SSB, AM, FM, DV, ATV

**TX Bass** (Default: 0)

**TX Treble** (Default: 0)

Sets the bass or treble level of the transmit audio.

### SSB

**TBW (WIDE)** (Default: 100 – 2900)

**TBW (MID)** (Default: 300 – 2700)

**TBW (NAR)** (Default: 500 – 2500)

Sets the transmission passband width to wide, mid, or narrow, by changing the lower and upper cut-off frequencies.

### SSB-D

**TBW** (Default: 300 – 2700)

Sets the transmission passband width by changing the lower and upper cut-off frequencies.

## Function

**MENU** » **SET > Function**

**Beep Level** (Default: 50%)

Sets the beep output level.

① If “Beep (Confirmation)” is set to “OFF,” no beeps sound.

**Beep Level Limit** (Default: ON)

Selects whether or not to limit the volume up to a specified level.

- OFF: Does not limit the volume level.
- ON: Limits the volume level.

**Beep (Confirmation)** (Default: ON)

Turns the Confirmation beep ON or OFF.

- OFF: Turns OFF the function for silent operation.
- ON: A beep sounds when a switch is pushed or the touch panel is touched.

① If “Beep Level” is set to “0%,” no beep sounds.

**Home CH Beep** (Default: ON)

Turns the Home CH Beep ON or OFF.

① In the VFO or Memory mode, when the Home Channel frequency or the Home Channel Memory is selected, the Home CH Beep sounds.

① In the DR screen, when the Home Channel Access repeater is set in FROM, the Home CH Beep sounds.

- OFF: No beep sounds.
- ON: Sounds a beep when you select the Home Channel.

**Band Edge Beep** (Default: ON (Default))

Selects an option for the Band Edge Beep function.

- OFF: Turns OFF the function.
- ON (Default): A beep sounds when you tune out of, or back into the default amateur band’s frequency range.
- ON (User): A beep sounds when you tune out of, or back into a user programmed amateur band’s frequency range.
- ON (User) & TX Limit: A beep sounds when you tune out of, or back into a user programmed amateur band’s frequency range. Transmitting is inhibited outside of the range.

① If “Beep Level” is set to “0%,” no beep sounds.



**FM/DV Center Error** (Default: ON)

Turns the FM/DV Center Error indication ON or OFF. The RX indicator shows the received signal deviation. When an off-center signal is received, the indicator blinks green.

- OFF: Turns OFF the function.
- ON: Turns ON the function.

**Auto Power OFF** (Default: OFF)

Selects whether or not to automatically turn OFF the transceiver after inactivity for this set period of time.

① "AUTO POWER OFF" is displayed and beeps sound 5 seconds before turning OFF the transceiver. If you operate the transceiver during this period of time, the Auto Power OFF timer is reset.

- OFF: Does not turn OFF the transceiver.
- 30/60/90/120min:  
Turns OFF the transceiver after inactivity for this set period of time.

**MENU** » SET > Function > TX Delay

<b>144M</b>	(Default: OFF)
<b>430M</b>	(Default: OFF)
<b>1200M</b>	(Default: OFF)
<b>2400M</b>	(Default: OFF)
<b>5600M</b>	(Default: OFF)
<b>10G</b>	(Default: OFF)

Sets the TX delay time on each band.

① If an external equipment's rise time is slower than that of the IC-905, a reflected wave is produced, and it may damage the IC-905 or the external device. To prevent this, set the appropriate delay time so that no reflected wave or timing damage occurs.

① Select "OFF" for no delay.

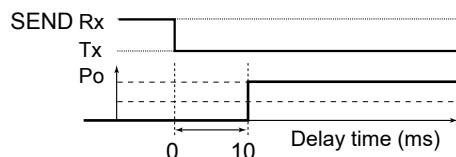
**MENU** » SET > Function**Time-Out Timer** (Default: 10min)

Sets the Time-out Timer to OFF, 3, 5, 10, 20, or 30 minutes to prevent an accidental prolonged transmission.

① Select "OFF" for no time limit.

**PTT Lock** (Default: OFF)

Turns the PTT Lock function ON or OFF. To prevent accidental transmissions, this function inhibits all transmissions.

- OFF: Turns OFF the function.
- ON: Inhibits all transmissions.

**MENU** » SET > Function > SPLIT**Quick SPLIT** (Default: ON)

Turns the Quick SPLIT function ON or OFF.

This function automatically turns ON the SPLIT function, and sets the frequency and mode to the VFO that is not displayed (VFO A or AFO B), according to the SPLIT Offset setting.

- OFF: Turns OFF the function.
- ON: Turns ON the function.

**SPLIT Offset** (Default: 0.000 MHz)

Sets the SPLIT offset between -9.999 and +9.999 MHz. The SPLIT offset is the difference between the receive and transmit frequencies for the Quick SPLIT function.

**SPLIT LOCK** (Default: OFF)

Turns the Split Lock function ON or OFF.

The SPLIT LOCK function enables you to adjust the transmit frequency while holding down **XFC**, even while the Dial Lock function is activated. To prevent accidentally changing the receive frequency by rotating **MAIN DIAL**, use both the SPLIT LOCK and Dial Lock functions (p. 3-8).

- OFF: Turns OFF the function.
- ON: Turns ON the function.

## Function

**MENU** » **SET > Function**

### Auto Repeater (Default: ON (DUP))

① This item is displayed in only the USA version.  
The Auto repeater function automatically turns the duplex operation and tone encoder ON or OFF.

- OFF: Turns OFF the function.
- ON (DUP): Turns ON the duplex settings only.
- ON (DUP, TONE): Turns ON the duplex settings and the tone encoder function.

### RTTY Mark Frequency (Default: 2125)

Selects the RTTY mark frequency.

① When the internal RTTY decoder is used, 2125 Hz is automatically selected.

### RTTY Shift Width (Default: 170)

Selects the RTTY shift width.

① When the internal RTTY decoder is used, 170 Hz is automatically selected.

### RTTY Keying Polarity (Default: Normal)

Selects the RTTY keying polarity.

- Normal: Key open/close = Mark/Space
- Reverse: Key open/close = Space/Mark

### ATV Audio Sub Carrier Frequency (Default: 6.5 MHz)

Sets the audio subcarrier frequency in the ATV mode.

- OFF: Does not receive and transmit audio signal in the ATV mode.
- 4.5 MHz: Sets the subcarrier frequency to 4.5 MHz.
- 6.0 MHz: Sets the subcarrier frequency to 6.0 MHz.
- 6.5 MHz: Sets the subcarrier frequency to 6.5 MHz.

**MENU** » **SET > Function > SPEECH**

### SPEECH Language (Default: English)

Sets the speech language to English or Japanese.

### Alphabet (Default: Normal)

Selects the type of phonetic announcement.

### SPEECH Speed (Default: Fast)

Sets the speech speed to Fast or Slow.

### RX Call Sign SPEECH (Default: ON (Kerchunk))

Turns the RX Call Sign Speech function ON or OFF for calls received in the DV mode.

### RX>CS SPEECH (Default: ON)

Turns the RX>CS Speech function ON or OFF.



### MIC Up/Down SPEECH (Default: OFF)

Turns the Microphone Up/Down Speech function ON or OFF.

- OFF: The frequency or repeater call sign is not announced.
- ON: The frequency or repeater call sign is announced, 1 second after pushing the microphone's [▲]/[▼] key. In the VFO, Memory, or Call channel mode, the frequency is announced. When using the DR function, the repeater call sign is announced.

### S-Level SPEECH (Default: ON)

Turns the S-meter level announcement ON or OFF.

- OFF: The operating mode and the operating frequency are announced when you push .
- ON: The signal strength level, the operating mode, and the operating frequency are announced when you push .

### MODE SPEECH (Default: OFF)

Turns the operating mode announcement ON or OFF.





- OFF: The selected operating mode is not announced.
- ON: The selected operating mode is announced.

### SPEECH Level (Default: 50%)

Sets the Voice Synthesizer audio output level.

**MENU** » **SET > Function****[SPEECH/LOCK] Switch** (Default: SPEECH/LOCK)

Selects  action.

- **SPEECH/LOCK:** Pushing  turns ON the Voice Synthesizer function. Holding down  turns the Lock function ON or OFF.
- **LOCK/SPEECH:** Pushing  turns the Lock function ON or OFF. Holding down  turns ON the Voice Synthesizer function.

**Lock Function** (Default: MAIN DIAL)

This function electronically locks **(MAIN DIAL)** or the panel display\* to prevent accidental changes.

\* Keys and dials are also locked except for **(POWER)** and .

**Memo Pad Quantity** (Default: 5)

Sets the number of memo pad channels to 5 or 10.

**Function of Touch for 1 sec MHz Digits**  
(Default: 1 MHz Step Tuning)

Selects the function when touching the MHz digits for 1 second.

- **Band Stacking Register:** Opens the BAND STACKING REGISTER screen.
- **1 MHz Step Tuning:** Turns the 1 MHz Step Tuning function ON or OFF.

**MAIN DIAL Auto TS** (Default: High)

Sets the Auto Tuning Step function for **(MAIN DIAL)**.

When rapidly rotating **(MAIN DIAL)**, the tuning step automatically changes according to the rotation speed.

- **OFF:** Auto tuning step is turned OFF.
- **Low:** Approximately two times faster.
- **High:** Approximately five times faster when the tuning step is set to 1 kHz or smaller. Approximately two times faster when the tuning step is set to 5 kHz or larger.

**MIC Up/Down Speed** (Default: Fast)

Selects the steps per second when changing an operating frequency by holding down the microphone's **[▲]/[▼]** key.

- **Slow:** Low speed (25 tuning steps/second)
- **Fast:** High speed (50 tuning steps/second)

**AFC Limit** (Default: ON)

Selects whether or not to limit the operating range of the Automatic Frequency Control (AFC) function.

- **OFF:** Turns OFF the function.
- **ON:** Limits the operating range of the AFC function. The limit value differs, depending on the IF filter width as shown below.

IF Filter width	AFC limit value
15 kHz	±10 kHz
10 kHz	±7 kHz
7 kHz	±5 kHz

**[NOTCH] Switch (SSB)** (Default: Auto/Manual)**[NOTCH] Switch (AM)** (Default: Auto/Manual)

Selects the Notch function used in the SSB or AM mode.

- **Auto:** Only the Auto Notch function can be used.
- **Manual:** Only the Manual Notch function can be used.
- **Auto/Manual:** Both the Auto and Manual Notch functions can be used.

**SSB/CW Synchronous Tuning** (Default: OFF)

Turns the Displayed Frequency Shift function ON or OFF. This function automatically shifts the frequency to match the CW pitch when the operating mode is toggled between SSB and CW.

- **OFF:** Turns OFF the function.
- **ON:** When the operating mode is changed between SSB and CW, the operating frequency shifts by the offset amount.

**CW Normal Side** (Default: USB)

Selects the carrier point in the CW normal mode.

- **LSB:** Sets the carrier point to the LSB side.
- **USB:** Sets the carrier point to the USB side.

**Power OFF Setting (for Remote Control)**  
(Default: Shutdown only)

Selects whether or not to display the Standby/Shutdown option dialog after holding down **(POWER)** for 1 second.

- **Shutdown only:** Shuts down the transceiver when you turn it OFF.
- **Standby/Shutdown:** Displays the Standby/Shutdown option dialog when you turn it OFF.

## Function

**MENU** » **SET > Function > Front Key Customize**

**[VOX/BK-IN]** (Default: VOX/BK-IN)  
**[AUTOTUNE/RX>CS/AFC]**  
 (Default: AUTOTUNE/RX>CS/AFC)

The function assignments for the **[VOX]** / **[BK-IN]** and **[AUTOTUNE/RX-CS]** / **[AFC]** keys on the front panel can be changed.  
 ① See page 8-7 about the functions.

**MENU** » **SET > Function > Remote MIC Key**

**[A]** (Default: Home CH)  
**[B]** (Default: VFO/MEMO)  
**[▲]** (Default: UP (VFO: kHz))  
**[▼]** (Default: DOWN (VFO: kHz))

The function assignments for the **[A]**, **[B]**, **[▲]**, and **[▼]** keys on the HM-243 speaker microphone can be changed.  
 ① See page 8-8 about the functions.

**Mode Select** (Default:  SSB/ CW/ RTTY/ AM/  
 FM/ DV/ DD/ ATV)

Selects whether or not to enable to select the mode by pushing the microphone's key that "MODE" is assigned to.  
 ① Displays "✓" when the mode is selectable.

**MENU** » **SET > Function**

**Keyboard Type** (Default: Full Keyboard)  
 Sets the keyboard entry type to Ten-Key or Full Keyboard.

**Full Keyboard Layout** (Default: English)  
 Sets the on-screen keyboard layout to English, German, or French.

**Screen Capture [POWER] Switch** (Default: OFF)  
 Assigns the Screen Capture function to **[POWER]**.  
 • OFF: **[POWER]** does not act as the Screen Capture key.  
 • ON: **[POWER]** acts as the Screen Capture key.  
 ① When both "Screen Capture [POWER] Switch" and "Screen OFF [POWER] Switch" are set to ON, pushing **[POWER]** displays the dialog to select "Screen OFF" or "Screen Capture."

**Screen Capture File Type** (Default: PNG)  
 Sets the file format for the Screen Capture function to PNG or BMP.

## REF Adjust

Adjusts the internal reference frequency.  
 ① While synchronizing to the received GPS data, "REF Adjust (Synchronizing to GPS)" is displayed, and you cannot manually adjust the internal reference frequency. To manually adjust, touch **[Cancel Sync]** to cancel the GPS synchronization.

## My Station

**MENU** » **SET > My Station**

### My Call Sign (DV)

The transceiver has a total of 6 memories to save your own call signs for use in the DV mode. You can enter a call sign of up to 8 digits. Also, a note of up to 4 characters, for operating transceiver type, area, and so on, can be entered.

### TX Message (DV)

The transceiver has a total of 5 memories to save short messages for simultaneous transmission in the DV mode.  
 Enter a message of up to 20 alphanumeric characters for each memory.  
 ① To transmit no message, select "OFF."

### My Call Sign (DD)

The transceiver has a total of 6 memories to save your own call signs for use in the DD mode. You can enter a call sign of up to 8 digits. Also, a note of up to 4 characters, for operating transceiver type, area, and so on, can be entered.

## The assignable key functions for Front Key

## [VOX/BK-IN]

Function	Description
TRANSMIT	Push to toggle between transmit and receive.
VOX/BK-IN*	Push to turn the VOX function in the Voice operation modes and the Break-in function in the CW mode ON or OFF.
P.AMP/ATT	<b>In the 144, 430, or 1200 MHz band</b> <ul style="list-style-type: none"> <li>Push to turn ON or OFF, and select one of two receive RF preamplifiers.</li> <li>Hold down for 1 second to turn the Attenuator ON or OFF.</li> </ul>
NOTCH*	Push to turn the Notch function ON or OFF, and select the Notch function type.
NB*	Push to turn the Noise Blanker ON or OFF.
NR*	Push to turn the Noise Reduction function ON or OFF.
SPLIT	<ul style="list-style-type: none"> <li>Push to turn the Split function ON or OFF.</li> <li>Hold down for 1 second to turn ON the Quick Split function.</li> </ul>
A/B	<ul style="list-style-type: none"> <li>Push to select the VFO A or VFO B.</li> <li>Hold down for 1 second to set the displayed VFO's frequency to the VFO that is not displayed.</li> </ul>
VFO/MEMO	<ul style="list-style-type: none"> <li>Push to select the VFO mode and the Memory mode.</li> <li>Hold down for 1 second to copy the Memory channel contents to the VFO.</li> </ul>
CD	Push to open the received call history.
PRESET	Push to open the PRESET screen.
Home CH	Push to directly select the Home Channel that is set to the selected mode (VFO/Memory) or DR screen. ①While in the Call channel mode, or when no Home CH is set, an error beep sounds.
Temporary Skip	Push to set the frequency to be skipped while scanning. The selected frequencies are temporarily skipped for faster scanning.
Voice/Keyer/RTTY Memory 1	<b>In the SSB, AM, FM, DV, or ATV mode</b> <ul style="list-style-type: none"> <li>Push to transmit the voice audio recorded on the SD card once.</li> <li>Hold down for 1 second to repeatedly transmit the voice audio.</li> </ul>
Voice/Keyer/RTTY Memory 2	①This key function can also be used on the DR screen. ①If the voice audio is not saved in the Voice TX memory (T1 ~ T4), this function is disabled. <b>In the CW mode</b> <ul style="list-style-type: none"> <li>Push to transmit the Keyer memory content once.</li> </ul>
Voice/Keyer/RTTY Memory 3	<ul style="list-style-type: none"> <li>Hold down for 1 second to repeatedly transmit the memory content.</li> </ul> ①If the Keyer memory content (M1 ~ M4) is not entered, this function is disabled.
Voice/Keyer/RTTY Memory 4	<b>In the RTTY mode</b> Push to transmit the RTTY memory content once. ①If the RTTY memory content (RT1 ~ RT4) is not entered, this function is disabled.

## [AUTOTUNE/RX&gt;CS/AFC]

Function	Description
AUTOTUNE/RX>CS/AFC	<b>In the CW mode</b> Push to automatically tune the operating frequency to a close-by CW signal. <b>In the FM or DV mode</b> Push to turn the Auto Frequency Control function ON or OFF. <b>In the DV or DD mode</b> Hold down for 1 second to display the RX History list.
CD/RX>CS	<ul style="list-style-type: none"> <li>Push to open the received call history.</li> <li>In the DV or DD mode, hold down for 1 second to display the RX History list.</li> </ul>
PRESET/RX>CS	<ul style="list-style-type: none"> <li>Push to open the PRESET screen.</li> <li>In the DV or DD mode, hold down for 1 second to display the RX History list.</li> </ul>
Home CH/RX>CS	<ul style="list-style-type: none"> <li>Push to directly select the Home Channel that is set to the selected mode (VFO/Memory) or DR screen. ①While in the Call channel mode, or when no Home CH is set, an error beep sounds.</li> <li>In the DV or DD mode, hold down for 1 second to display the RX History list.</li> </ul>
Temporary Skip/RX>CS	<ul style="list-style-type: none"> <li>Push to set the frequency to be skipped while scanning. The selected frequencies are temporarily skipped for faster scanning.</li> <li>In the DV or DD mode, hold down for 1 second to display the RX History list.</li> </ul>

\* Hold down for 1 second to open its function menu.

The assignable key functions for Remote MIC Key

Function	Description
---	No function
UP	Push to increase the frequency (in 50 Hz steps*), Memory channel, repeater, or select the next station call sign. * When the Tuning Step function is ON, increases the frequency in the selected Tuning Step.
DOWN	Push to decrease the frequency (in 50 Hz steps*), Memory channel, repeater, or select the previous station call sign. * When the Tuning Step function is ON, increases the frequency in the selected Tuning Step.
UP (VFO: kHz)	Push to increase the frequency (in the selected Tuning Step), Memory channel, repeater, or select the next station call sign.
DOWN (VFO: kHz)	Push to decrease the frequency (in the selected Tuning Step), Memory channel, repeater, or select the previous station call sign.
VOL UP	Push to increase the volume level.
VOL DOWN	Push to decrease the volume level.
XFC	Hold down for 1 second to monitor signals.
CALL	Push to select the Call channel mode.
VFO/MEMO	<ul style="list-style-type: none"> <li>Push to select the VFO mode and the Memory mode.</li> <li>Hold down for 1 second to copy the Memory channel contents to the VFO.</li> </ul>
DR	Push to turn the DR function ON or OFF.
FROM/TO (DR)	<b>In the DR screen</b> Push to select "FROM" or "TO."
Home CH	Push to directly select the Home Channel that is set to the selected mode (VFO/Memory) or DR screen. ① While in the Call channel mode, or when no Home CH is set, an error beep sounds.
BAND/GROUP UP	<b>In the VFO mode</b> <ul style="list-style-type: none"> <li>Push to increase an operating band.</li> <li>Hold down for 1 second to recall the Band Stacking Register contents.</li> </ul> <b>In the Memory mode</b> Push to increase the Memory group.
BAND/GROUP DOWN	<b>In the VFO mode</b> <ul style="list-style-type: none"> <li>Push to decrease an operating band.</li> <li>Hold down for 1 second to recall the Band Stacking Register contents.</li> </ul> <b>In the Memory mode</b> Push to decrease the Memory group.
SCAN	<ul style="list-style-type: none"> <li>Push to start the previously selected scan. While scanning, push to stop the scan.</li> <li>Hold down for 1 second to open the SCAN SELECT screen.</li> </ul>

Function	Description
Temporary Skip	Push to set the frequency to be skipped while scanning. The selected frequencies are temporarily skipped for faster scanning.
SPEECH	Push to announce the frequency, operating mode, or call sign. ① In the VFO, Memory, or Call channel mode, the frequency and the operating mode are announced. ① In the DR screen, the call sign is announced. If Simplex is selected, the frequency is announced.
MODE	<ul style="list-style-type: none"> <li>Push to select the operating mode.</li> <li>Hold down to toggle USB and LSB, CW and CW-R, or RTTY and RTTY-R.</li> </ul>
RF Power	Push to adjust the transmit output power.
Voice/Keyer/RTTY Memory 1	<b>In the SSB, AM, FM, DV, or ATV mode</b> <ul style="list-style-type: none"> <li>Push to transmit the voice audio recorded on the SD card once.</li> <li>Hold down for 1 second to repeatedly transmit the voice audio.</li> </ul> ① This key function can also be used on the DR screen. ① If the voice audio is not saved in the Voice TX memory (T1 ~ T4), this function is disabled.
Voice/Keyer/RTTY Memory 2	<b>In the CW mode</b> <ul style="list-style-type: none"> <li>Push to transmit the Keyer memory content once.</li> <li>Hold down for 1 second to repeatedly transmit the memory content.</li> </ul> ① If the Keyer memory content (M1 ~ M4) is not entered, this function is disabled.
Voice/Keyer/RTTY Memory 3	<b>In the RTTY mode</b> Push to transmit the RTTY memory content once. ① If the RTTY memory content (RT1 ~ RT4) is not entered, this function is disabled.
Voice/Keyer/RTTY Memory 4	<b>In the RTTY mode</b> Push to transmit the RTTY memory content once. ① If the RTTY memory content (RT1 ~ RT4) is not entered, this function is disabled.
T-CALL	Push to transmit a 1750 Hz Tone. (Only for European version.)
RX>CS	<b>In the DV or DD mode</b> <ul style="list-style-type: none"> <li>Push to display the RX History list.</li> <li>Hold down for 1 second to set the last calling station's call sign to "TO" (destination).</li> </ul>
TS	<ul style="list-style-type: none"> <li>Push to turn the Tuning Step function ON or OFF.</li> <li>Hold down for 1 second to open the TS screen.</li> </ul>
MPAD	<ul style="list-style-type: none"> <li>Push to sequentially call up the contents in the Memo Pads.</li> <li>Hold down for 1 second to save the displayed contents into the Memo Pad.</li> </ul>
SPLIT	<ul style="list-style-type: none"> <li>Push to turn the Split function ON or OFF.</li> <li>Hold down for 1 second to turn ON the Quick Split function.</li> </ul>
A/B	<ul style="list-style-type: none"> <li>Push to select the VFO A or VFO B.</li> <li>Hold down for 1 second to set the displayed VFO's frequency to the VFO that is not displayed.</li> </ul>

## DV/DD Set

**MENU** » **SET > DV/DD Set**

### Standby Beep

(Default: ON (to me:Alarm/High Tone))

Turns the Standby Beep function ON or OFF.

This function sounds a beep after a received signal disappears, in the DV mode.

- OFF: Does not sound a beep after a received signal disappears.
- ON: Sounds a beep after a received signal disappears.
- ON (to me:High Tone):  
Sounds a high pitched beep when a received signal that is addressed to your call sign (MY) disappears. When any other received signal disappears, a regular beep sounds.
- ON (to me:Alarm/High Tone):  
Sounds alarm (PiRoPiRoPiRo) when a received signal that is addressed to your call sign (MY) disappears. When any other received signal disappears, a regular beep sounds.

① The standby beep sounds even when “Beep (Confirmation)” is set to “OFF.”

① The standby beep output level depends on the “Beep level” setting.

### Auto Reply

(Default: OFF)

Sets the Automatic Reply function to ON, OFF, or Voice. This function automatically replies to a call addressed to your own call sign (MY), even if you are away from the transceiver.

- OFF: Turns OFF the function.
- ON: Replies with your own call sign (MY). (No audio reply is sent)
- Voice: Replies with your call sign (MY) and any Auto Reply message recorded on the SD card (up to 10 seconds). If no SD card is inserted, or no message is recorded, only your call sign is transmitted. The transmitted audio can be monitored.

① When “ON” or “Voice” is selected, the Automatic Reply function is automatically turned OFF when you push the microphone’s [PTT].

### DV Data TX

(Default: Auto)

Selects whether to manually or automatically transmit data in the DV mode.

- PTT: Push the microphone’s [PTT] to manually transmit data.
- Auto: When data is input from a PC through the [USB] port, the transceiver automatically transmits it.

**MENU** » **SET > DV/DD Set > DV Fast Data**

### Fast Data

(Default: OFF)

Selects whether or not to use the DV Fast Data function for data communication in the DV mode.

The DV Fast Data function uses the data and the audio frames to send data approximately 3.5 times faster than the normal speed. So, no audio can be sent.

- OFF: Sends data at a slow speed (approximately 950 bps).
- ON: Sends data at a fast speed (approximately 3480 bps).

① Even if “ON” is selected, when you push the microphone’s [PTT], the data is sent at the slow speed, because the audio frame is used for the audio transmission. The GPS data speed is set in “GPS Data Speed.”

### GPS Data Speed

(Default: Slow)

Sets the GPS data speed when the data is sent using the DV Fast Data function.

- Slow: Sends GPS data in the slow speed (approximately 950 bps).
- Fast: Sends GPS data in the fast speed (approximately 3480 bps).

### TX Delay (PTT)

(Default: 2sec)

Sets the time for when the transceiver returns to receive after sending DV data in the DV Fast Data mode using the microphone’s [PTT].

- OFF: After releasing [PTT], the transceiver returns to receive.
- 1 ~ 10sec: After releasing [PTT], the transceiver sends data using the DV Fast Data mode for this set period. When the TX data is completely sent within this set period, the transceiver automatically returns to receive.

**NOTE:** This function is usable only when “DV Data TX” is set to “PTT.”

## DV/DD Set

**MENU** » **SET > DV/DD Set**

### Digital Monitor (Default: Auto)

Selects a receive mode when **XFC** is pushed in the DV mode.

- Auto: Receives in the DV mode or the FM mode, depending on the received signal.
- Digital: Receives in the DV mode.
- Analog: Receives in the FM mode.

### Digital Repeater Set (Default: ON)

Turns the Digital Repeater Set function ON or OFF. When accessing a repeater that has a call sign that is different than the transceiver's setting, this function reads the repeater's transmit signal and automatically sets the repeater call sign.

- OFF: Turns OFF the function.
- ON: Automatically sets the repeater call sign.

### DV Auto Detect (Default: OFF)

Turns the DV mode Automatic Detect function ON or OFF. When in the DV mode, if you receive a non-digital signal, this function automatically sets the operating mode to the FM mode.

- OFF: Turns OFF the function. The operating mode is fixed to the DV mode.
- ON: Automatically selects the FM mode for temporary operation.

### RX Record (RPT) (Default: ALL)

The transceiver can record the data of up to 50 individual calls. When the received signal includes a status message ("UR?" or "RPT?") that is sent back from the access repeater, you can record up to 50 messages, or only the last call, in the Received Call Record.

- ALL: Records up to 50 calls.
- Latest Only: Records only the last call.

### BK (Default: OFF)

The Break-in (BK) function enables you to break into a conversation, where the two other stations are communicating with call sign squelch enabled.

- OFF: Turns OFF the function.
- ON: Turns ON the function.

① The BK function is automatically turned OFF when the transceiver is turned OFF.

### EMR (Default: OFF)

The Enhanced Monitor Request (EMR) function enables all transceivers that receive an EMR signal in the DV mode automatically open their squelch to receive the signal.

- OFF: Turns OFF the function.
- ON: Turns ON the function.

① The EMR function is automatically turned OFF when the transceiver is turned OFF.

### EMR AF Level (Default: 50%)

Sets the audio output level when an EMR communication mode signal is received.

When an EMR signal is received, the audio will be heard at the programmed level, or the transceiver's audio level, whichever is higher. To disable the setting, set to "0."

**NOTE:** After an EMR signal disappears, the audio level will remain at the EMR level. In this case, rotate **(AF/RF/SQ)** to adjust the audio level.

### DD TX Inhibit (Power ON) (Default: ON)

Selects the TX INHIBIT setting when the transceiver is turned ON.

- OFF: Sets to OFF.
- ON: Sets to ON.

### DD Packet Output (Default: Normal)

Sets the condition for outputting the packets in the DD mode.

- Normal: Outputs packets when:
  - A call addressed to your own call sign or a non-call sign specific call (CQCQCQ) is received.
  - An EMR signal is received.
  - A break-in call is received.
- All: Outputs all packets.



## QSO/RX Log

**MENU** » **SET > QSO/RX Log**

### QSO Log (Default: OFF)

Selects whether or not to make a communication log on an SD card.

The communication log is made on an SD card, and saved in the “csv” format.

① This function requires an SD card (User supplied).

- OFF: The QSO Log function is OFF.
- ON: The transceiver makes a log on the SD card. The transceiver starts making a log when you begin talking.

#### TIP:

- The folder name is automatically created, as [IC-905\QsoLog].
- The file name is automatically created, as shown in the example below:  
Log start date and time: 28th February 2023 15:30:00  
File name: 20230228\_153000.csv
- The log contents are not displayed on the transceiver.
- You can display the log contents on a PC.

### RX History Log (Default: OFF)

Selects whether or not to make a DV mode’s receive history log on an SD card.

The receive history log is made on an SD card, and saved in the “csv” format.

① This function requires an SD card (User supplied).

- OFF: The RX History Log function is OFF.
- ON: The transceiver makes a DV mode’s receive history log on the SD card. The transceiver starts making a receive history log when you finish talking.

#### TIP:

- The folder name is automatically created, as [IC-905\RxLog].
- The file name is automatically created, as shown in the example below:  
Log start date and time: 28th February 2023 15:30:00  
File name: 20230228\_153000.csv
- The log contents are not displayed on the transceiver.
- You can display the log contents on a PC.

**MENU** » **SET > QSO/RX Log > CSV Format**

### Separator/Decimal (Default: Sep[,.] Dec[.])

① The default value may differ, depending on the transceiver version.

Selects the separator and the decimal character for the CSV format.

- Sep [,] Dec [.]: Separator is “,” and Decimal is “.”
- Sep [.] Dec [.]: Separator is “.” and Decimal is “.”
- Sep [.] Dec [,]: Separator is “.” and Decimal is “,”

### Date (Default: mm/dd/yyyy)

① The default value may differ, depending on the transceiver version.

Selects the date format from “yyyy/mm/dd,” “mm/dd/yyyy,” and “dd/mm/yyyy.” (y: year, m: month, d: day)

## 8 SET MODE

The call log contents are shown below:

Contents	Example		Descriptions
TX/RX	TX	RX	Transmission and reception
Date	2/28/2023 13:51:48	2/28/2023 13:51:48	Date and time the call was started.
Frequency	438.010000	438.010000	Operating frequency
Mode	DV	DV	Operating mode (USB/USB-D/LSB/LSB-D/CW/CW-R/RTTY/RTTY-R/AM/AM-D/ FM/FM-D/DV/DD/ATV)
My Latitude	34.764667	34.764667	Your latitude (unit: degrees) (+: North latitude, -: South latitude)
My Longitude	135.375333	135.375333	Your longitude (unit: degrees) (+: East longitude, -: West longitude)
My Altitude	50.5	50.5	Your altitude (unit: meters) Records to one decimal place.
RF Power	20%	(Blank)	TX output power level
S meter	(Blank)	S0	The relative signal strength of the receive signal (in 16 levels)
RPT Call Sign	JP3YHJ	JP3YHJ A	Repeater call sign (DV mode only)
TX Call Sign	CQCQCQ	(Blank)	TX Call sign (DV mode only)
RX Call Sign	(Blank)	JA3YUA A/905	RX Call sign/Note (DV mode only)
RX Latitude	(Blank)	34.764667	Caller's latitude, if sent. (unit: degrees) (+: North latitude, -: South latitude) Records only when you receive in the DV mode.
RX Longitude	(Blank)	135.375333	Caller's longitude, if sent. (unit: degrees) (+: East longitude, -: West longitude) Records only when you receive in the DV mode.
RX Altitude	(Blank)	30.5	Caller's altitude, if sent. (unit: meters) Records only when you receive in the DV mode.

The RX log contents are shown below:

Contents	Example	Descriptions
Frequency	438.010000	RX Frequency
Mode	DV	Operating mode (DV mode is fixed)
Caller	JA3YUA A	Call sign of the caller station (up to 8 characters)
/	905	Note after the call sign (up to 4 characters)
Called	CQCQCQ	Call sign of the called station
Rx RPT1	JP3YHH G	Access repeater call sign of the caller station, or the gateway repeater call sign of your local area repeater.
Rx RPT2	JP3YHH A	Access repeater call sign of the called station
Message	Hello CQ D-STAR!	Message included in the received call (up to 20 characters)
Status	(Blank)	Normal: blank, Uplink: "RPT UP", Access repeater reply: "UR?" or "RPT?"
Received date	2/28/2023 13:51:48	Date and time the call was received Depending on the setting, the format may differ.
BK	*	BK call: "**", Normal call: Blank
EMR	*	EMR call: "**", Normal call: Blank
Latitude	34.764667	Caller's latitude, if sent. (unit: degrees) (+: North latitude, -: South latitude)
Longitude	135.375333	Caller's longitude, if sent. (unit: degrees) (+: East longitude, -: West longitude)
Altitude	30.5	Caller's altitude, if sent. (unit: meters) Records to one decimal place.
SSID	-A	Caller's SSID, if sent. (0, -1 to -15, -A to -Z)
D-PRS Symbol	Car	Icon: Converts to text, None: Code
Course	123	Caller's course (unit: degrees)
Speed	23.5	Caller's speed (unit: km/h) Records to one decimal place.
Power	49	TX power (unit: watts)
Height	24	Antenna height (unit: meters)
Gain	6	Antenna gain (unit: dB)
Directivity	Omni	Antenna directivity (Omni, 45, 90, 135, 180, 225, 270, 315, or 360)
Object/Item Name	HAM FES	Object name or Item name (up to 9 characters)
Data Type	Live Object	Data type of Object or Item (Live or Kill)
Temperature	20.5	Temperature (unit: °C) Records to one decimal places.
Rainfall	253.7	Rainfall (unit: mm) Records to one decimal places.
Rainfall (24 Hours)	253.7	Rainfall (24 Hours) (unit: mm) Records to one decimal places.
Rainfall (Midnight)	253.7	Rainfall (Midnight) (unit: mm) Records to one decimal places.
Wind Direction	315	Wind Direction (unit: degrees)
Wind Speed	10.0	Wind Speed (unit: m/s) Records to one decimal place.
Gust Speed	10.0	Gust Speed (unit: m/s) Records to one decimal place.
Barometric	1013.0	Barometric (unit: hPa) Records to one decimal place.
Humidity	85	Humidity (unit: %)
GPS Time Stamp	12:00:00	Time data that the caller station acquires along with the position data
GPS Message	Osaka City/IC-905	Caller is "NMEA": Records the GPS message Caller is "D-PRS": Records the D-PRS comment

## Connectors

**MENU** » **SET > Connectors**

### Speaker MIC AF Output (Default: ON)

Selects the AF Output device when the speaker microphone is connected.

- OFF (Internal Speaker): Sets the internal speaker as the AF Output device.
- ON: Sets the speaker microphone as the AF Output device.

### SP Jack Function (Default: Speaker)

Selects the audio output from the [EXT-SP] jack.

- Speaker: The audio is output from only the Left channel through the amplifier for a speaker.
- Phone: The audio is output from only the Left channel through the amplifier for a headphone.
- Phone (L+R): The audio is output from the Right and Left channels through the amplifier for a headphone.

### Phones Level (Default: 0)

Sets the audio output level ratio of the headphone and internal speaker between -15 and +15.

**MENU** » **SET > Connectors > USB/AV-OUT AF/IF Output**

① The signal is output from the [AV-OUT] jack only when in the ATV mode.

### Output Select (Default: AF)

Selects the signal output from the [USB] port and the [AV-OUT] jack.

- AF: An AF signal is output.
- IF: A 12 kHz IF signal is output.

### AF Output Level (Default: 50%)

Sets the AF output level of the [USB] port and the [AV-OUT] jack, when "Output Select" of USB is set to "AF."

### AF SQL (Default: OFF (Open))

Selects whether or not to output the audio from the [USB] port and the [AV-OUT] jack, depending on the squelch state, when "Output Select" of USB is set to "AF."

- OFF (Open): The squelch is always open, regardless of the transceiver's squelch level.
- ON: The squelch opens and closes, according to the transceiver's squelch level.

### AF Beep/Speech... Output (Default: OFF)

Sets the Beep and Speech audio output setting of the [USB] port and the [AV-OUT] jack, when "Output Select" of USB is set to "AF."

- OFF: The beep and speech audio are not output.
- ON: The beep and speech audio are output.

### IF Output Level (Default: 50%)

Sets the IF output level of the [USB] port and the [AV-OUT] jack, when "Output Select" of USB is set to "IF."

**MENU** » **SET > Connectors > LAN AF/IF Output**

### Output Select (Default: AF)

Selects the signal output from the [LAN] connector.

- AF: An AF signal is output.
- IF: A 12 kHz IF signal is output.

### AF SQL (Default: ON)

Selects whether or not to output the audio from the [LAN] connector, depending on the squelch state, when "Output Select" of LAN is set to "AF."

- OFF (Open): The squelch is always open, regardless of the transceiver's squelch level.
- ON: The squelch opens and closes, depending on the transceiver's squelch level.

**MENU** » **SET > Connectors > MOD Input**

### USB MOD Level (Default: 50%)

### LAN MOD Level (Default: 50%)

Sets the modulation input level of each interface.

### DATA OFF MOD (Default: MIC,USB)

### DATA MOD (Default: USB)

In the SSB, AM, or FM mode, selects the connector(s) to input the modulation signal when the Data mode is OFF, or ON.

### AV-IN MOD Level (Default: 50%)

Sets the modulation input level of the Audio terminal on the [AV-IN] jack.

### ATV MOD (Default: MIC, AV-IN)

Selects the connector(s) to input the modulation signal when in the ATV mode.

**MENU** » SET > Connectors > **SEND Output**

<b>144M</b>	(Default: ON)
<b>430M</b>	(Default: ON)
<b>1200M</b>	(Default: ON)
<b>2400M</b>	(Default: ON)
<b>5600M</b>	(Default: ON)
<b>10G</b>	(Default: ON)

Selects whether or not to switch the SEND terminal output level of the controller's [SEND] jack and the RF unit's [ACC] socket (SEND pin) to the Low level when transmitting.

- OFF: Does not switch to Low level.
- ON: Switches to Low level.

**MENU** » SET > Connectors > **USB SEND/Keying**

**TIP:** This is the setting for the terminal used for data communication when you operate the transceiver using software on a PC.

When you connect the transceiver to the PC with a USB cable, 2 COM ports are recognized on the PC. To confirm USB (A)/USB (B), open the COM port properties, and confirm the "Value" on the "Details" tab.

**USB SEND** (Default: OFF)

Sets the USB terminal of the controller to receive the SEND signal from the software on the PC. Select the same terminal as the terminal set by the software.

- ① You cannot select the terminal which is already selected in the "USB Keying (CW)" or "USB Keying (RTTY)" item.

**USB Keying (CW)** (Default: OFF)

Sets the USB terminal of the controller to receive the CW Keying signal from the software on the PC. Select the same terminal as the terminal set by the software.

- ① You cannot select the terminal which is already selected in the "USB SEND" or "USB Keying (RTTY)" item.

**USB Keying (RTTY)** (Default: OFF)

Sets the USB terminal of the controller to receive the RTTY Keying signal from the software on the PC. Select the same terminal as the terminal set by the software.

- ① You cannot select the terminal which is already selected in the "USB SEND" or "USB Keying (CW)" item.

**MENU** » SET > Connectors > **External Keypad**

<b>VOICE</b>	(Default: OFF)
<b>KEYER</b>	(Default: OFF)
<b>RTTY</b>	(Default: OFF)

Enables each memory (voice, keyer, RTTY) transmission using an external keypad.

**MENU** » SET > Connectors > **CI-V****CI-V Address** (Default: AC)

Sets the CI-V address in hexadecimal code.

- ① "AC" is the default address of the IC-905.

**CI-V Transceive** (Default: ON)

Turns the Transceive function ON or OFF.

- OFF: The status is not output.
- ON: The status is output. When you change a setting on the transceiver, the same change is automatically set on other connected transceivers or receivers, and vice versa.

**CI-V USB Echo Back** (Default: OFF)

Turns the Data Echo Back function ON or OFF, when remotely controlling the IC-905 through the [USB] CI-V port.

**MENU** » SET > Connectors > **USB (B) Function****USB (B) Function** (Default: OFF)

The transceiver has 2 virtual COM ports, A and B. In this item, sets the function to be assigned to USB (B).

- ① USB (A) is used for programming, or CI-V operation.
- ① When connecting to a USB port on your PC that is installed the USB driver, USB (A) and USB (B) are named as "IC-905 Serial Port A (CI-V)" and "IC-905 Serial Port B."
- OFF: Does not assign the function to USB (B).
  - RTTY Decode: Outputs the decoded data of the RTTY signal.
  - DV Data: Inputs or outputs low speed data for the DV mode.
  - Weather: Inputs the weather data entries.

**GPS Out** (Default: OFF)

Selects whether or not to output the position data to USB (B).

- OFF: Does not output the position data to USB (B).
  - ON: Outputs the position data to USB (B).
- ① It is valid when "USB (B) Function" is set to "OFF" or "DV Data."

## Connectors

**MENU** » **SET > Connectors**

**MIC Jack 8V Output** (Default: OFF)

Selects whether or not to output 8 V from the [MIC] jack.

- OFF: Output 3.3 V from the [MIC] jack.
- ON: Output 8 V from the [MIC] jack.

**REF OUT** (Default: Auto (CX-10G:ON))

Sets the timing of the reference frequency signal output from the [REF OUT 10 MHz/-10 dBm] connector on the RF unit.

- Auto (CX-10G:ON): Automatically outputs the reference signal only when the optional CX-10G is connected.
- ON: Outputs the reference signal anytime.

## Network

**MENU** » **SET > Network**

**DHCP (Valid after Restart)** (Default: ON)

Turns the DHCP function ON or OFF.

- OFF: Uses a static IP address.
- ON: Uses the DHCP function. If a DHCP server is in your network environment, the IP address is automatically obtained.

**IP Address (Valid after Restart)** (Default: 192.168.0.10)

Sets the static IP address.

① You cannot set the same address as "Default Gateway."

**Subnet Mask (Valid after Restart)** (Default: 255.255.255.0(24 bit))

Sets the subnet mask to connect to your PC or Local Area Network (LAN), through your Router.

**Default Gateway (Valid after Restart)** (Default: . . . .)

Sets the Default Gateway of the IC-905.

When you remotely control the IC-905 or use the Internal Gateway function, a Default Gateway setting is required.

**Primary DNS Server (Valid after Restart)** (Default: . . . .)

Sets the Primary DNS Server address.

**2nd DNS Server (Valid after Restart)** (Default: . . . .)

If there are two DNS server addresses, sets the secondary DNS server address.

**Network Name**

If you are operating the IC-905 using the optional RS-BA1 or transferring a picture to the IC-905 using the optional ST-4001W, enter a network name of up to 15 characters.

**MENU** » **SET > Network > Remote Settings**

**Network Control (Valid after Restart)** (Default: OFF)

Selects whether or not to remotely control the IC-905.

- OFF: Disables remote control of the IC-905.
- ON: Enables remote control of the IC-905.

**Control Port (UDP) (Valid after Restart)**

(Default: 50001)

Sets a port number for the control signal transfers between the IC-905 and the remote station, when you remotely control the IC-905.

**Serial Port (UDP) (Valid after Restart)**

(Default: 50002)

Sets a port number for the serial data transfers between the IC-905 and the remote station, when you remotely control the IC-905.

**Audio Port (UDP) (Valid after Restart)**

(Default: 50003)

Sets a port number for the audio signal transfers between the IC-905 and the remote station, when you remotely control the IC-905.

**Internet Access Line (Valid after Restart)**

(Default: FTTH)

Selects the Internet access line setting for the IP remote control.

**MENU** » SET > Network > Remote Settings > **Network User1**

**MENU** » SET > Network > Remote Settings > **Network User2**

**Network User1 ID****Network User2 ID**

Sets a user name of up to 16 characters to use when you remotely control the IC-905.

**Network User1 Password****Network User2 Password**

Sets a user password.

- ① The password must include a minimum of 8 characters and a maximum of 16 characters.
- ① You cannot use a password that consists of only the same characters.

**Network User1 Administrator** (Default: NO)

**Network User2 Administrator** (Default: NO)

Selects whether or not to set the user as an administrator.

Only an authorized user can disconnect communication between the IC-905 and the remote station.

**MENU** » SET > Network > **Remote Settings**

**Network Radio Name** (Default: IC-905)

Sets the IC-905's name of up to 16 characters that is displayed in the remote control software, when you remotely control the IC-905.

## Display

**MENU** » **SET > Display**

### LCD Backlight

Sets the LCD backlight brightness.

- ① When "(Auto Adjusting)" is displayed to the right of the screen title, the backlight brightness is automatically adjusted using the ambient light sensor. Touching [Auto Adjust] turns this function ON or OFF. (Default: ON)
- ① **DO NOT** cover the sensor when the Auto Adjust function is ON.

### Screen Saver (Default: 60min)

Sets the Screen Saver function.

This function activates and automatically turns OFF the screen when no operation is performed for the preset period of time.

### Screen OFF [POWER] Switch (Default: ON)

Selects whether or not to turn OFF the screen by pushing **POWER**.

- OFF: Pushing **POWER** does not turn OFF the screen.
- ON: Pushing **POWER** turns OFF the screen.
- ① When the screen is OFF by pushing **POWER**, keys and dials are also locked except for pushing **POWER** and rotating **(AF/RF/SQL)**.
- ① When both "Screen Capture [POWER] Switch" and "Screen OFF [POWER] Switch" are set to ON, pushing **POWER** displays the dialog to select "Screen OFF" or "Screen Capture."

### Meter Peak Hold (Default: ON)

Turns the Meter Peak Hold function ON or OFF.

### Multi-func. Meter Voltage Display (Default: VD)

Selects the voltage meter displayed on the Multi-function meter.

- DC IN: Displays the voltage of the external power source.
- VD: Displays the drain voltage of the final amplifier MOS-FETs.

### Memory Name (Default: ON)

Turns the Memory name display in the Memory mode ON or OFF.

### Group Name Popup (Default: ON)

Selects whether or not to display the group name when you change the memory channel group.

### RX Call Sign Display (Default: Normal)

In the DV mode, selects whether or not to display the call sign and the message of the caller station when a call is received.

- OFF: Does not display the caller station's call sign and message.
- Normal: The caller station's call sign and message automatically scroll once, and then disappear.
- RX Hold: The caller station's call sign and message automatically scroll once, and then the call sign is displayed on the controller's display until the signal disappears.
- Hold: The caller station's call sign and message automatically scroll once, and then the call sign is displayed on the controller's display until the signal disappears. When the signal disappears, the call sign and the message are each repeatedly displayed for 2 seconds.

- ① When "Normal," "RX Hold," or "Hold" is selected, and if the call sign and name of the caller station is programmed in your memory, the programmed name is displayed after displaying the call sign.

### RX Position Indicator (Default: ON)

Selects whether or not to display the indicator when position data is included in the signal received in the DV mode.

- OFF: No indicator is displayed, even though the position data is included in the received signal.
- ON: The indicator is displayed when the position data is included in the received signal.

- ① When "RX Call Sign Display" is set to "OFF," the indicator is not displayed, even though position data is included in the received signal.

### RX Position Display (Default: ON)

Selects whether or not to display in a dialog when the caller station's position data is included in the signal received in the DV mode.

- OFF: No data is displayed in a dialog.
- ON: When the caller station's position data is included in the signal, its data is displayed in a dialog.

- ① The time period to display the dialog depends on the "RX Position Display Timer" setting.



**MENU** » **SET > Display****RX Position Display Timer** (Default: 10sec)

Sets the RX position data's time period to display in a dialog.

- 5/10/15/30sec: Displays the caller's position for this set period of time.
- Hold: Displays the caller's position until you operate the transceiver.

**Reply Position Display** (Default: ON)

Selects whether or not to display the caller's position when it is included in the Auto Reply signal.

- OFF: Does not display the caller's position.
- ON: Automatically displays the caller's position.

**RX Picture Indicator** (Default: ON)

Selects whether or not to display the RX Picture Indicator when a picture is included in the received signal.

- OFF: No indicator is displayed, even if a picture is included in the received signal.
- ON: The indicator is displayed when a picture is included in the received signal.

① When "RX Call Sign Display" is set to "OFF," the indicator is not displayed, even if a picture is included in the received signal.

**DV RX Backlight** (Default: ON)

Turns the DV RX Backlight function ON or OFF. In the DV mode, this function turns ON the screen while displaying the calling station's call sign or a received message.

- OFF: The function is OFF.
- ON: The screen automatically turns ON when displaying the calling station's call sign or a received message. The screen stays ON while the call sign or message is scrolling.

**TX Call Sign Display** (Default: Your Call Sign)

Selects whether or not to display My or Your call sign while transmitting.

- OFF: Turns OFF the function.
- Your Call Sign: Displays and scrolls the call sign of the target station.
- My Call Sign: Displays and scrolls your own call sign.

① When "Your Call Sign" is selected, and if the call sign and name of the caller station is programmed in your memory, the programmed name is displayed after the call sign.

**Scroll Speed** (Default: Fast)

Sets the scrolling speed of the message, call sign, or other text, that are displayed on the controller's display to "Slow" or "Fast."

**Opening Message** (Default: ON)

Selects whether or not to display the opening message at power ON.

**Power ON Check** (Default: ON)

Selects whether or not to display the RF Power level and the power source voltage at power ON.

① When the external DC power source voltage is above 15.6V, "HI Voltage" is displayed.

**MENU** » **SET > Display > Display Unit****Latitude/Longitude** (Default: ddd° mm.mm')

Selects the format to display the latitude and the longitude.

**Altitude/Distance** (Default: ft/mi)

① The default value may differ, depending on the transceiver version.

Selects the format to display the distance and elevation.

**Speed** (Default: mph)

① The default value may differ, depending on the transceiver version.

Selects the format to display the speed.

**Temperature** (Default: °F)

① The default value may differ, depending on the transceiver version.

Selects the format to display the temperature.

**Barometric** (Default: inHg)

① The default value may differ, depending on the transceiver version.

Selects the format to display the barometric pressure.

**Rainfall** (Default: inch)

① The default value may differ, depending on the transceiver version.

Selects the format to display the amount of rainfall.

**Wind Speed** (Default: mph)

① The default value may differ, depending on the transceiver version.

Selects the format to display the wind speed.

## Display

**MENU** » **SET > Display****Display Language** (Default: English)

① This item is displayed only when the “System Language” item is set to “Japanese.”

Sets the screen display language type to English or Japanese.

**System Language** (Default: English)

Sets the system language of the transceiver.

- English: The system language of the transceiver is English. Only alphabetical characters (A to Z, a to z, 0 to 9) and symbols (! “ # \$ % & ‘ ( ) \* + , - . / : ; < = > ? @ [ \ ] ^ \_ ` { | } ~) can be displayed. If Japanese characters (Kanji, Hiragana, and Katakana) are included, the display shows “=” or “\_” instead of that character. In that case, you can only delete “=” or “\_” in the transceiver’s edit mode.
- Japanese: The system language of the transceiver is Japanese. Kanji, Hiragana, and Katakana characters, and the 2-bytes symbols can be displayed. To display such characters in the DR screen or Menu mode, set “Display Language” to “Japanese.”

① When this item is set to “English,” “Display Language” is not displayed.

When you set the system language of the transceiver to Japanese, the transceiver has the capability to display both English and Japanese characters.

HOWEVER, if you select Japanese, all menu items throughout the transceiver system will be displayed in only Japanese characters.

There will be no English item names. Unless you are fluent in reading Japanese characters, use this feature with extreme caution.

If you have changed the transceiver’s language to Japanese and do not understand the menu system in the new setting, you will have to change the language back to English by doing a partial reset of the transceiver CPU. A partial reset will not clear your call sign databases.

To do a partial reset of the CPU, do the following steps:

1. Push **MENU**.
2. Touch **[SET]**.
3. Touch the item (with the “etc” icon) shown below.



4. Touch the bottom item shown below.



5. Touch the upper item shown below.



6. Touch the left item.

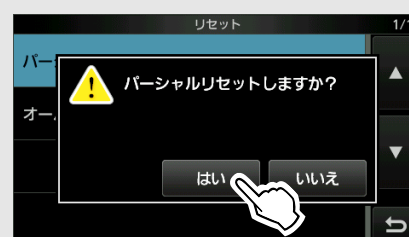

- The transceiver displays “PARTIAL RESET,” then the partial reset is completed.

## Time Set

**MENU** » SET > Time Set > **Date/Time**

### Date

Sets the date (Year/Month/Day).

① The day of the week is automatically set.

### Time

Sets the current time.

① The time is displayed in the 24 hour format.

### <<NTP TIME SYNC>>

Synchronizes the internal clock with the time management server.

① To use this function, you need an Internet connection and default gateway settings.

### NTP Function (Default: ON)

Automatically obtains the current time from the NTP server.

### NTP Server Address (Default: time.nist.gov)

Sets NTP server address.

### GPS Time Correct (Default: Auto)

Selects whether or not the time data is automatically corrected by a received GPS sentence.

**MENU** » SET > **Time Set**

### UTC Offset (Default: ±0:00)

Sets the UTC offset time.

## SD Card

**MENU** » SET > **SD Card**

### Load Setting

Selects the saved data file to load.

### Save Setting

Saves the setting data onto an SD card.

**MENU** » SET > SD Card > **Import/Export**

### Import

Import the Memory channel contents, UR call sign, repeater list, or GPS memory data in the CSV format file.

### Export

Export the Memory channel contents, UR call sign, repeater list, or GPS memory data in the CSV format file.

**MENU** » SET > SD Card > Import/Export > **CSV Format**

### Separator/Decimal (Default: Sep [,] Dec [.] )

① The default value may differ, depending on the transceiver version.

Selects the separator and the decimal character for the CSV format.

- Sep [,] Dec [.]: Separator is “,” and Decimal is “.”
- Sep [;] Dec [.]: Separator is “;” and Decimal is “.”
- Sep [;] Dec [,]: Separator is “;” and Decimal is “,”

### Date (Default: mm/dd/yyyy)

① The default value may differ, depending on the transceiver version.

Selects the date format from “yyyy/mm/dd,” “mm/dd/yyyy,” and “dd/mm/yyyy.” (y: year, m: month, d: day)

**MENU** » SET > **SD Card**

### SD Card Info

Displays the SD card capacity and the time remaining for voice recording.

### Screen Capture View

Displays the selected screen capture.

### SD Card

**MENU** » **SET > SD Card**

#### TX/RX Picture View

Displays the pictures that are saved on the SD card.

- ① The transceiver cannot display the picture while transmitting picture data.
- ① The transceiver can display up to 500 pictures.

#### Firmware Update

Displays the Firmware Update mode.

#### Firmware Update (CX-10G)

Displays the CX-10G's Firmware Update mode.

#### Format

Formats the SD card.

If you use a brand new SD card, be sure to format it in the transceiver.

#### Unmount

Unmounts the SD card.

Before you remove a card when the transceiver is ON, be sure to electrically unmount it. Otherwise, the data may be corrupted or deleted.

### Others

**MENU** » **SET > Others > Information**

#### Version

Displays the transceiver firmware's version number.

#### MAC Address (Controller)

Displays the controller's MAC address.

#### MAC Address (RF Unit)

Displays the RF unit's MAC address.

#### SERIAL NO. (Controller)

Displays the controller's serial number.

#### SERIAL NO. (RF Unit)

Displays the RF unit's serial number.

#### SERIAL NO. (CX-10G)

Displays the CX-10G's serial number.

**MENU** » **SET > Others > Clone**

#### Clone Mode

Selects to enter the clone mode to read or write the CS-905 data from or to the PC.

- ① Restart the transceiver to cancel the clone mode.

**MENU** » **SET > Others**

#### Touch Screen Calibration

Touch to adjust the touch screen.

- ① See the Advanced Manual for details.

**MENU** » **SET > Others > Reset**

#### Partial Reset

Resets operating settings to their default values (VFO frequency, VFO settings, menu contents).

- ① See page 10-2 for details.

#### All Reset

Clears all data and returns all settings to their factory defaults. Memory channel contents, filter setting, and so on will all be cleared, so you will need to rewrite your operating settings.

- ① See page 10-2 for details.

## Setting the date and time

### ◇ Setting the date

1. Open the “Date” screen.  
**[MENU]** » **[SET > Time Set > Date/Time > Date]**
2. Touch [+] or [-] to set the date.
3. Touch [SET] to save the date.



4. To close the DATE/TIME screen, push **[EXIT]** several times.

### ◇ Setting the current time

1. Open the “Time” screen.  
**[MENU]** » **[SET > Time Set > Date/Time > Time]**
2. Touch [+] or [-] to set the current time.
3. Touch [SET] to save the time.

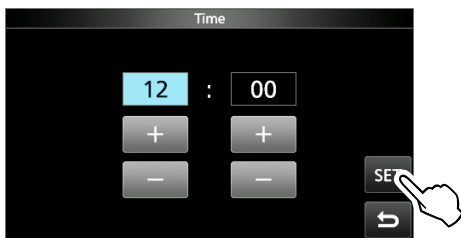

4. To close the DATE/TIME screen, push **[EXIT]** several times.

### ◇ Setting the UTC offset

1. Open the “UTC Offset” screen.  
**[MENU]** » **[SET > Time Set > UTC Offset]**
2. Touch [+] or [-] to set the UTC offset.
3. Touch **[⇒]** to save the UTC offset.



4. To close the TIME SET screen, push **[EXIT]** several times.

### NOTE: The backup battery for the internal clock

The IC-905 has a rechargeable Lithium battery to back up the internal clock. If you connect the transceiver to a power source, the battery is charged, and it keeps the correct clock setting. However, if you do not connect the transceiver to a power source for a long period of time, the battery will discharge. In that case, the transceiver resets the internal clock.

The battery is charged while connecting to a power source, whether the transceiver's power is ON or OFF.

# 10 MAINTENANCE

## Cleaning



**DO NOT** use harsh solvents such as benzene or alcohol when cleaning, because they will damage the transceiver surfaces.



If the transceiver becomes dusty or dirty, wipe it clean with a dry, soft cloth.

## Replacing fuse

A fuse is installed in each fuse holder of the supplied DC power cable, to protect the transceiver. If the transceiver does not turn ON because a fuse blows, find and repair the cause of the problem. Then replace any blown fuse with a new, adequately rated fuse. (FGBO)

① Spare fuses are supplied with the transceiver.

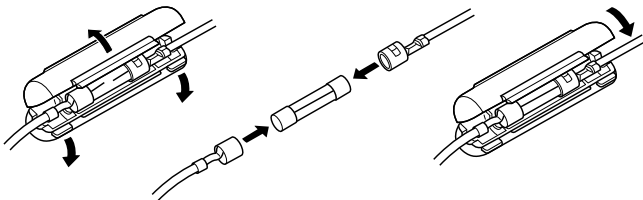

### ⚠ WARNING!

- Disconnect the DC power cable from the external power source before replacing the fuse.
- **NEVER** use fuses other than specified ones.

### Fuse Coding explanation

Fuse Coding: FUSE 250 V 8 A

Fuse Voltage Rating: 250 Volts

Fuse Current Rating: 8 Amperes

## Resetting

Occasionally, erroneous information may be displayed. This may be caused by static electricity or by other factors.

If this problem occurs, turn OFF the transceiver.

After waiting a few seconds, turn ON the transceiver again.

If the problem still exists, perform a **Partial reset**, as described to the right.

If the problem still exists after a Partial reset, perform an **All reset**, also described to the right.

**NOTE:** An All reset clears all data and returns all settings to their factory defaults. Save memory channel content, setting status, and so on, onto an SD card before an All reset. (p. 6-2)

### After performing a Partial reset

A Partial reset resets operating settings to their default values (VFO frequency, VFO settings, menu contents) without clearing the items listed below:

- Memory channel contents
- Keyer memory contents
- RTTY memory contents
- Call sign memories
- Message contents
- DTMF memory contents
- GPS memory contents
- Repeater list contents
- Network settings
- REF Adjust
- User Band Edges
- Fixed Edges
- Allowed call sign list contents
- Preset memory content

### After performing an All reset

An All reset clears all data and returns all settings to their factory defaults. Memory channel contents, filter settings, and so on will all be cleared, so you will need to rewrite your operating settings unless you have a backup.

Resetting

◇ Partial reset

1. Open the RESET screen.  
**MENU** » **SET > Others > Reset**
2. Touch “Partial Reset.”



3. Touch [YES].

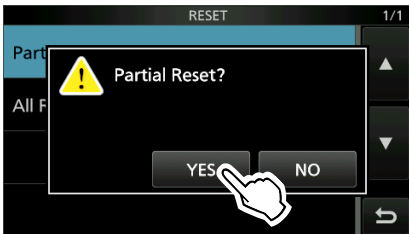

① After resetting, the default VFO mode screen is displayed.

◇ All reset

1. Open the RESET screen.  
**MENU** » **SET > Others > Reset**
2. Touch “All Reset.”

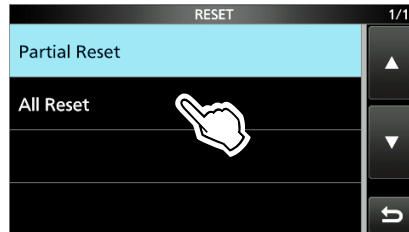

3. Touch [NEXT].

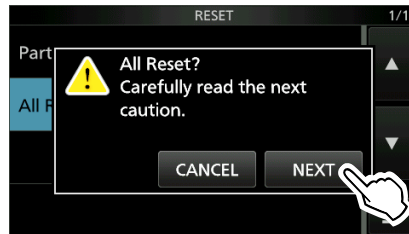

4. After carefully reading the displayed message, touch [YES] to perform the All reset.



① After resetting, the default VFO mode screen is displayed.

10

**When you cannot enter the Set mode**  
 If a touch screen operation error or an unexpected operation occurs, you cannot enter the Set mode. In this case, perform an All reset, as described below:

1. Turn OFF the transceiver.
2. While holding down **RIT/ATX** and **XFC**, push **POWER**.

① If you cannot turn the transceiver ON or OFF by using **POWER**, perform an All reset by connecting an external power source while holding down **RIT/ATX** and **XFC**.

## Troubleshooting

The following chart is designed to help you solve problems that are not equipment malfunctions. If you are unable to locate the cause of a problem or solve it through the use of this chart, contact your nearest Icom Dealer or Service Center.

① See the Advanced Manual for the problems when communicating through a repeater.

① “AM” indicates the PDF type Advanced manual.

① “CG” indicates the Connection guide.

Problem	Possible cause	Solution	REF.
Power does not turn ON when <b>POWER</b> is pushed.	The power cable is not properly connected.	Properly reconnect the DC power cable.	p. 2-2
	The external power supply is turned OFF.	Turn ON the external power supply.	–
	A DC power cable fuse is blown.	Find and repair the cause of the problem, and then replace the damaged fuse with a new one.	p. 10-1
No sound is heard from the speaker.	The audio level is too low.	Rotate <b>(AF/RF/SQL)</b> clockwise to obtain a suitable listening level.	p. 3-1
	The squelch is closed.	Adjust the squelch level.	p. 3-9
	The external speaker is connected.	Disconnect the external speaker.	–
	In the FM mode, the Tone Squelch function is turned ON.	Turn OFF the Tone Squelch function.	AM
	In the ATV mode, “ATV Audio Sub Carrier Frequency” is set to “OFF.”	Set “ATV Audio Sub Carrier Frequency” to other than “OFF.”	AM
Sensitivity is too low, and only strong signals are heard.	The Attenuator is activated.	Turn OFF the Attenuator.	p. 4-1
	RF gain control is set too low. (“RFG” is displayed.)	Set the RF gain higher until “RFG” just goes off.	p. 3-9
	The antenna is defective, or the coaxial cable is defective.	Repair the problem and then reconnect the antenna.	–
	You are using an antenna that is not suitable for the band you have selected.	Connect an antenna suitable for the operating band.	p. 13-5
	The squelch is closed.	Adjust the squelch level.	p. 3-9
The transceiver automatically switches to transmit while receiving.	The VOX function is ON.	Push <b>(VOX)</b> to turn OFF the VOX function.	AM
	The VOX gain is set too high.	Adjust the VOX gain.	
	The transceiver receives the SEND signal from the software on the PC.	Confirm the “USB SEND” setting.	p. 8-15
No power output or the output power is too low.	The operating frequency is outside a ham band.	Set the frequency to a ham band.	p. 3-3
	The transmit output power is set too low.	Adjust the RF POWER in the Multi-function menu.	p. 3-11
	The modulation input signal level is set too low.	Adjust the MIC GAIN level in the Multi-function menu.	p. 3-9
	The output power is limited because of power amplifier protection.	Stop transmitting, and then wait until the temperature of the power amplifier FET drops sufficiently.	AM
	The microphone is bad, or the [MIC] jack is shorted or defective.	Test the microphone and check the [MIC] jack.	p. 13-1
	The antenna SWR is more than 3:1.	Adjust the antenna for an SWR of less than 3:1.	AM
	In the ATV mode, the input from [AV-IN] is excessive (over deviation). The TX indicator blinks red.	Set “AV-IN Video Input Level” to a lower level.	AM



Troubleshooting

Problem	Possible cause	Solution	REF.
The transmit signal is unclear or distorted in the SSB mode.	The transceiver's microphone gain is too high.	Adjust the MIC GAIN level so that the meter reading swings between 30 and 50% of the ALC scale.	p. 3-9
The received audio in the SSB mode is unclear or distorted.	The incorrect sideband is selected.	Toggle between USB and LSB.	p. 3-2
	The PBT function is activated.	Hold down to clear the <b>(TWIN PBT)</b> settings.	p. 4-5
Cannot contact with another station, even if receiving and transmitting seem normal.	The Split function is ON, and the transmit and receive frequencies are different. ( <b>SPLIT</b> is displayed.)	Touch [SPLIT] in the FUNCTION screen to turn OFF the Split function.	p. 4-11
	The RIT function or the ΔTX function is ON, and the transmit and receive frequencies are different. ("RIT" or "ΔTX" is displayed.)	Push <b>(RIT/ΔTX)</b> to turn OFF the function.	p. 4-2
There is no response after transmitting.	The Duplex function is ON, and the transmit and receive frequencies are different.	Touch [DUP] several times in the FUNCTION screen to turn OFF the Duplex function.	AM
The operating frequency does not change when rotating <b>(MAIN DIAL)</b> .	The Dial Lock function is ON.	Hold down <b>(SPEECH)</b> to turn OFF the Dial Lock function.	p. 3-8
In the VFO mode, the operating frequency is not properly changed by rotating <b>(MULTI)</b> .	The function assigned to <b>(MULTI)</b> is wrong.	Push <b>(RIT/ΔTX)</b> to turn OFF the RIT or ΔTX function.	p. 4-2
		Hold down <b>(MULTI)</b> to assign the kHz Tuning Control or Select the Memory Channel function.	p. 1-8
The display turns OFF.	The Screen Saver function is ON. (The POWER indicator blinks green.)	Operate something (push key, and so on) to reset the screen saver startup time.	p. 8-18
The backlight brightness automatically changes.	The Auto Adjust function is ON.	Touch [Auto Adjust] in the "LCD Backlight" screen to turn OFF the Auto Adjust function. ("Auto Adjusting" disappears.)	p. 8-18
A Programmed scan does not start.	The same frequencies have been set in the scan edges (00 ~ 24).	Set different frequencies in the scan edges.	AM
A Memory scan does not start.	No, or only 1 memory channel is set.	Set at least 2 memory channels.	AM
A Select memory scan does not start.	No, or only 1 memory channel is assigned as a Select channel.	Assign at least 2 memory channels as Select channels for the scan.	AM
While operating in the Memory mode, you changed the operating frequency, mode, and so on, but a selected memory channel contents are not changed.	They were not overwrite already in the selected memory.	When you want to save the changed settings, touch [MW] for 1 second to write them into the memory channel on the VFO/MEMORY screen.	AM
Cannot hear the speech after pushing <b>(SPEECH)</b> .	The speech level is too low.	Adjust "SPEECH Level" in the Speech setting.	p. 8-4
"OVF" is displayed.	An excessively strong signal is being received.	Set the RF gain lower. ("RFG" is displayed.)	p. 3-9
		Turn ON the Attenuator.	p. 4-1
		Turn OFF the Preamplifier (P.AMP OFF).	p. 4-1
The spectrum scope's sensitivity is too low, and only strong signals are displayed.	The reference level is too low.	Set the reference level to a higher level.	p. 5-1

## Troubleshooting

Problem	Possible cause	Solution	REF.
Cannot transmit voice memories.	"DATA OFF MOD" is set to "USB" or "LAN" by control from an external device, and so on.	Set "DATA OFF MOD" to "MIC,USB" (default) or "MIC."	p. 8-14
Cannot save TX/RX histories or sound data.	An SD card is not inserted.	Insert an SD card.	p. 6-1
"No SD Card is found." is displayed.	An SD card is not recognized.	Confirm that an SD card is inserted. Reinsert an SD card. Exchange with a new SD card.	p. 6-1
"- No File -" is displayed on the FIRMWARE UPDATE screen.	The firmware file is in an incorrect folder.	Copy the firmware file into the IC-905 folder.	AM
	The firmware file name is different.	Download the firmware file again.	
	The SD card is not formatted.	Format the SD card.	p. 6-1
The touch screen is not working correctly.	The touched point and the detected point may be different.	Calibrate the touch screen on the OTHERS screen.	AM
The current time is reset.	The transceiver has not been used for a long time, with the DC power cable disconnected.	Connect the transceiver to the power source to charge the backup battery of the internal clock.	p. 9-1
Even when turning ON the NTP function, the clock is not automatically set.	The transceiver is not connected to the Internet.	Confirm the network settings.	p. 13-3
	The transceiver IP address is wrong.	Turn ON the DHCP function to automatically get the IP address, or set the correct IP address.	p. 8-16
"The RF unit is not detected. Check connection and restart the IC-905." is displayed.	The RF unit is not connected properly.	Reconnect the RF unit properly.	CG
	A communication error occurred between the controller and the RF unit due to interference with the radio waves transmitted from other devices.	Take measures against the interference.	-
"A communication error occurred between the controller and the RF unit. Please restart the IC-905." is displayed, even when restarting the transceiver.	The controller cannot communicate with the RF unit.	Reinstall the firmware update.	AM
In the ATV mode, the received or transmitted video are corrupted or distorted.	When inputting PAL or SECAM video, "ATV Audio Sub Carrier Frequency" is set to "4.5 MHz," and interference occurs with audio and video signals.	Change the input device to a one that uses a compatible video format standard.	-
		Set "ATV Audio Sub Carrier Frequency" to other than "4.5 MHz."	AM

## ◇ General

- Frequency coverage (unit: MHz):

USA version

Receiver/Transmitter	144.000000 ~ 148.000000
	430.000000 ~ 450.000000
	1240.000000 ~ 1300.000000
	2300.000000 ~ 2309.999999
	2390.000001 ~ 2450.000000
	5650.000000 ~ 5925.000000

EUR version

Receiver/Transmitter	144.000000 ~ 146.000000
	430.000000 ~ 440.000000
	1240.000000 ~ 1300.000000
	2300.000000 ~ 2450.000000
	5650.000000 ~ 5850.000000

① **BE SURE** to check your local regulations or laws to select the appropriate operating frequency.

- Operating modes: USB/LSB (J3E), CW (A1A), RTTY (F1B), AM (A3E), FM (F2D/F3E), DV (F7W), DD (F1D), and ATV (F3F/F8W)
- Number of memory channels: 500 channels (in up to 100 groups)
- Number of program scan channels: 25 channels (2 edge frequencies in each channel)
- Number of call channels: 12 channels (2 channels in each of the 6 bands)
- Number of repeater memories: 2500
- Number of GPS memories: 300
- Antenna impedance: 50 Ω unbalanced
- Antenna connector: SMA (50 Ω) × 2 (for the 2400/5600 MHz band)  
Type-N × 1 (for the 144/430/1200 MHz band)
- Power source requirement:
 

Controller	13.8 V DC (±15%)
------------	------------------
- Operating temperature range:
 

Controller	0°C ~ 50°C, 32°F ~ 122°F
RF unit	-10°C ~ +55°C, 14°F ~ 131°F
- Frequency stability: Less than ±65 ppb  
(Total deviation including variations in operating temperature.)
- Frequency resolution: 1 Hz (minimum)
- Power consumption:
 

Receive	Standby	2 A (typical)
	Maximum audio	Less than 3 A
Transmit	Maximum power	Less than 5.5 A

 (When using an external DC power (13.8 V DC) and supplied control cable)
- Dimensions (projections not included):
 

Controller	200.0 (W) × 83.5 (H) × 82.0 (D) mm, 7.9 (W) × 3.3 (H) × 3.2 (D) in
RF unit	172.0 (W) × 87.0 (H) × 210.0 (D) mm, 6.8 (W) × 3.4 (H) × 8.3 (D) in
- Weight (approximate, without the supplied accessories):
 

Controller	940 g, 2.1 lb
RF unit	3.2 kg, 7.1 lb

# 11 SPECIFICATIONS

## ◇ Receiver

- Receive system:
 

144/430 MHz band	RF Direct Sampling
1200/2400/5600 MHz band	Down Conversion IF Sampling
- Intermediate frequency:
 

1200 MHz band	1st 331 ~ 371 MHz
2400/5600 MHz band	1st 914 MHz band, 2nd 346 MHz band
- Sensitivity:
 

SSB/CW (Filter: SOFT, 10 dB S/N)	
144/430/1200/2400 MHz band	Less than -19 dB $\mu$ V (0.11 $\mu$ V)
5600 MHz band	Less than -16 dB $\mu$ V (0.15 $\mu$ V)
AM (at 10 dB S/N)	
144/430/1200/2400 MHz band	Less than 0 dB $\mu$ V (1.0 $\mu$ V)
5600 MHz band	Less than +3 dB $\mu$ V (1.4 $\mu$ V)
FM (at 12 dB SINAD)	
144/430/1200/2400 MHz band	Less than -15 dB $\mu$ V (0.17 $\mu$ V)
5600 MHz band	Less than -12 dB $\mu$ V (0.25 $\mu$ V)
DV (1% BER (PN9))	
144/430/1200/2400 MHz band	Less than -9 dB $\mu$ V (0.35 $\mu$ V)
5600 MHz band	Less than -6 dB $\mu$ V (0.50 $\mu$ V)
DD (1% BER (PN9))	
1200/2400 MHz band	Less than +4 dB $\mu$ V (1.58 $\mu$ V)
5600 MHz band	Less than +7 dB $\mu$ V (2.23 $\mu$ V)

① Preamp is ON in the 144 MHz, 430 MHz, and 1200 MHz bands.
- Sensitivity for the European version:
 

SSB/CW (BW=2.4 kHz, Filter: SOFT, 12 dB SINAD)	
144/430/1200/2400/5600 MHz band	Less than -6 dB $\mu$ Vemf
AM (BW=4 kHz, 60% Modulation, 12 dB SINAD)	
144/430/1200/2400/5600 MHz band	Less than 0 dB $\mu$ Vemf
FM (BW=7 kHz, 60% Modulation, 12 dB SINAD)	
144/430/1200/2400/5600 MHz band	Less than -6 dB $\mu$ Vemf

① Preamp is ON in the 144 MHz, 430 MHz, and 1200 MHz bands.
- Selectivity (Filter: SHARP):
 

SSB (BW=2.4 kHz)	More than 2.4 kHz/-3 dB
	Less than 3.6 kHz/-60 dB
CW (BW=500 Hz)	More than 500 Hz/-3 dB
	Less than 700 Hz/-60 dB
RTTY (BW=500 Hz)	More than 500 Hz/-3 dB
	Less than 700 Hz/-60 dB
AM (BW=6 kHz)	More than 6.0 kHz/-3 dB
	Less than 15 kHz/-60 dB
FM (BW=15 kHz)	More than 12.0 kHz/-6 dB
	Less than 20 kHz/-60 dB
DV (Channel spacing=12.5 kHz)	Less than -50 dB
DD (Channel spacing=300 kHz)	Less than -40 dB
- Spurious and image rejection:
 

SSB/CW	
144/430 MHz band	More than 70 dB
1200/2400/5600 MHz band	More than 50 dB
AM/FM/DV	
144/430 MHz band	More than 60 dB
1200/2400/5600 MHz band	More than 50 dB
DD	
1200/2400/5600 MHz band	More than 50 dB

- Audio output power:
  - Internal speaker More than 0.53 W (12  $\Omega$  load, 1 kHz, 10% distortion)
  - External speaker More than 0.2 W (8  $\Omega$  load, 1 kHz, 10% distortion)
  - [AV-OUT] jack More than -6 dBV (maximum audio, 600  $\Omega$  load) (audio),  
1 V<sub>p-p</sub> (test pattern) (video)
- AF output impedance:
  - [EXT-SP] jack 8  $\Omega$
  - [AV-OUT] jack 600  $\Omega$  (audio), 75  $\Omega$  (video)
- RIT variable range:  $\pm$ 9.999 kHz
- ANF attenuation: More than 30 dB (with 1 kHz single tone)
- MNF attenuation: More than 70 dB
- NR attenuation: More than 6 dB (noise rejection in SSB)

### ◇ Transmitter

- Transmit output power:
  - 144/430 MHz band
    - SSB, CW, FM, RTTY, DV 10 W
    - AM 2.5 W
  - 1200 MHz band
    - SSB, CW, FM, RTTY, DV, DD, ATV 10 W
    - AM 2.5 W
  - 2400/5600 MHz band
    - SSB, CW, FM, RTTY, DV, DD, ATV 2 W
    - AM 0.5 W
- Modulation system:
  - SSB Digital PSN modulation
  - FM Digital Reactance modulation
  - AM Digital Low power modulation
  - DV Digital GMSK modulation
  - DD Digital GMSK modulation
  - ATV Digital Reactance modulation
- Spurious emission:
  - Spurious domain emission
    - 144 MHz band Less than -60 dBc
    - 430 MHz band Less than -60 dBc
    - 1200 MHz band Less than -53 dBc
    - 2400 MHz band Less than -46 dBc
    - 5600 MHz band Less than -46 dBc
  - Out-of-band domain emission
    - 144 MHz band Less than -60 dBc
    - 430 MHz band Less than -60 dBc
    - 1200 MHz band Less than -50 dBc
    - 2400 MHz band Less than -43 dBc
    - 5600 MHz band Less than -43 dBc
- Carrier suppression: More than 50 dB
- Unwanted sideband suppression: More than 50 dB
- Microphone impedance: 2.2 k $\Omega$  (When using PTT by the [MIC] jack, 1.2 k $\Omega$ )
- AV-IN video signal level: 1 V<sub>p-p</sub> (typical, 75 $\Omega$  load)

① All stated specifications are typical and subject to change without notice or obligation.

① See the CX-10G Instruction manual about the specifications on the 10 GHz band.

# 12 OPTIONS

## Options

(As of February 2023)

### Speaker microphone

**HM-243** SPEAKER MICROPHONE  
The same as supplied.

### Antennas

**AH-24** 2.4 GHz COLLINEAR ANTENNA  
**AH-56** 5.6 GHz COLLINEAR ANTENNA  
**AH-100** 10 GHz COLLINEAR ANTENNA  
**AH-109PB** 10 GHz PARABOLA ANTENNA

### Software

**RS-BA1 Version 2** IP REMOTE CONTROL SOFTWARE  
① The RS-BA1 will be compatible with the IC-905 in the near future.

**NOTE:** To remotely control transceivers using the RS-BA1 software, **BE SURE** to comply with your local regulations.

### Cables

**OPC-2513** CONTROL CABLE  
Approximately 20 m, 65.6 feet  
**OPC-2509** CONTROL CABLE  
Approximately 50 m, 164.0 feet

### Other

**CX-10G** TRANSVERTER

### About the free download software

CS-905	PROGRAMMING SOFTWARE
RS-MS3A (For Android™ devices)	TERMINAL MODE/ACCESS POINT MODE SOFTWARE
RS-MS3W (For Windows)	TERMINAL MODE/ACCESS POINT MODE SOFTWARE
ST-4001A (For Android™ devices)	PICTURE UTILITY SOFTWARE
ST-4001I (For iOS devices)	PICTURE UTILITY SOFTWARE
ST-4001W (For Windows)	PICTURE UTILITY SOFTWARE

You can download each manual and guide from the Icom website.

<https://www.icomjapan.com/support/>

Before using, read each manual and guide, and use it according to the instructions.

① To add or expand a function, or to improve the performance, the software version may be upgraded. Before you update your software version, see the instructions and cautions described on the Icom website.

## Controller

### ◇ [ELEC-KEY]

Connect a Paddle key or Straight key.

① You can select the key type.

**MENU** » **KEYER > EDIT/SET > CW-KEY SET > Key Type**

- Paddle key

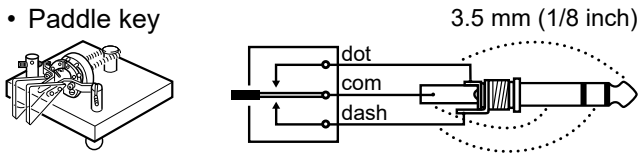

- Straight key

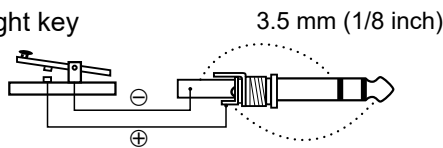

By connecting an external keypad to [KEY] with a circuit as shown below, you can send the content from one of the 8 memories. You can send the content from a CW Keyer Memory (M1 ~ M8), SSB/AM/FM/DV/ATV Voice Memory (T1 ~ T8), or RTTY Memory (RT1 ~ RT8) to be transmitted.

- Push a switch to send the memory content.
- Hold down the switch for 1 second to repeatedly send the memory content.

① To use the external keypad, turn ON the following item.

**MENU** » **SET > Connectors > External Keypad**

① The external keypad shown below is not supplied by Icom.

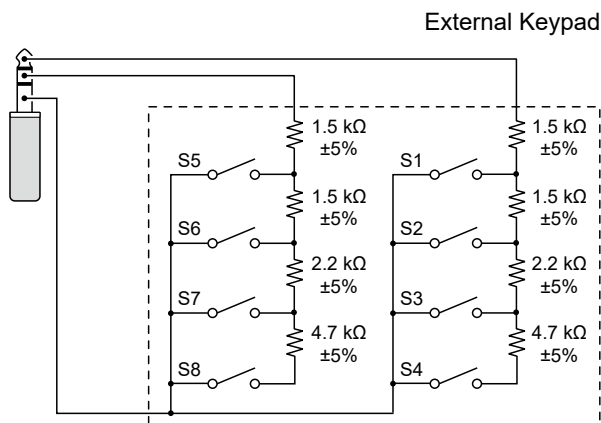

**TIP:** You can alternate between an external keypad and a Paddle key or Straight key, when connecting them in parallel.

### ◇ [EXT-SP]

Connect standard stereo headphones or an external speaker.

The output impedance and output level differ, depending on the amplifier that is used.

① You can change the amplifier that is used. Set the following item according to the connected device.

**MENU** » **SET > Connectors > SP Jack Function**

3.5 mm (1/8 inch)

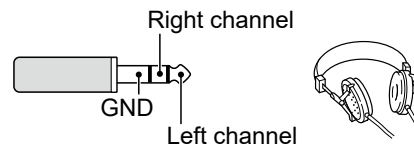

When using the amplifier for a speaker:

- Output impedance: 8 Ω
- Output level: More than 200 mW (8 Ω load, 10% distortion)

When using the amplifier for a headset:

- Output impedance: 16 Ω
- Output level: More than 5 mW (16 Ω load, 10% distortion)

### ◇ [MIC-SP]

Connect a supplied speaker microphone's speaker plug.

① You can select the audio output device when the speaker microphone is connected.

**MENU** » **SET > Connectors > Speaker MIC AF Output**

3.5 mm (1/8 inch)

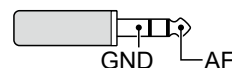

- Output impedance: 8 Ω
- Output level: More than 200 mW (8 Ω load, 10% distortion)

### ◇ [MIC]

Connect a supplied speaker microphone's plug or an external microphone's plug.

2.5 mm GND +3.3 V/+8 V input\*

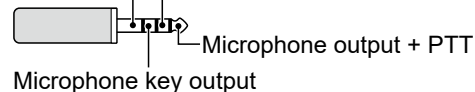

\* You can select from +3.3 V (through 470 Ω) and +8.0 V (Maximum 10 mA)

**MENU** » **SET > Connectors > MIC Jack 8V Output**

① Confirm that the transceiver is OFF before connecting or disconnecting optional equipment.

# 13 CONNECTOR INFORMATION

## Controller

### ◇ [AV-IN]

Connects to an external device, such as a camera, to input audio and video.

3.5 mm (1/8 inch)

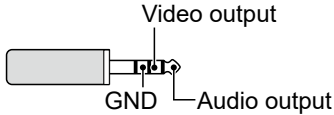

Audio:

- Input impedance: 600Ω
- Input level: -10 dBV ±3 dB

Video:

- Input impedance: 75 Ω

### ◇ [AV-OUT]

Connects to an external device, such as a monitor, for displaying the received audio and video.

3.5 mm (1/8 inch)

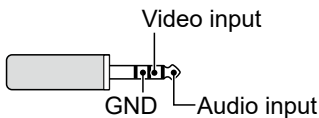

Audio:

- Output impedance: 600 Ω
- Output level: -10 dBV ±3 dB

Video:

- Output impedance: 75 Ω

① The audio and video are output only when in the ATV mode.

① You can change the audio signal output type and output level.

**MENU** » SET > Connectors > **USB/AV-OUT AF/IF Output**

① You can change the video signal output level.

**MENU** » VIDEO > SET > Video Level > **AV-OUT Video Output Level**

### ◇ [SEND]

An external unit controls the transceiver. When the SEND pin goes to ground, the transceiver transmits.

- Input voltage (RX): 2.0 to 20.0 V
- Input voltage (TX): -0.5 to +0.8 V
- Current flow: Maximum 20 mA

The pin goes low when the transceiver transmits.

- Output voltage (TX): Less than 0.1 V
- Current flow: Maximum 200 mA

3.5 mm (1/8 inch)

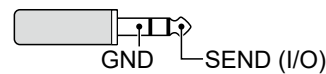

When the SEND terminal controls an inductive load, such as a relay, a counter-electromotive force can malfunction or damage the transceiver. To prevent this, we recommend adding a switching diode, such as a 1SS133, on the load side of the circuit to absorb the counter-electromotive force.

① When the diode is added, a delay in relay switching may occur. Be sure to check its switching action before operating.

① Be sure to connect the Negative terminal of the Power source for Relay to the [SEND] jack's GND terminal.

#### Example: [SEND/ALC] jack

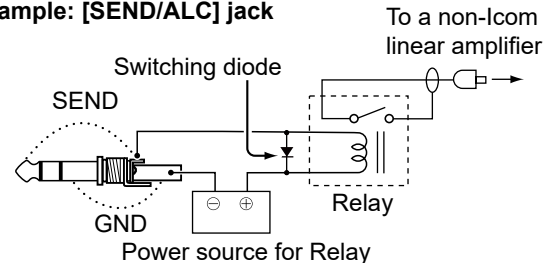



## Controller

## ◇ [LAN]

- Time synchronization by an NTP server.
- Outputting the demodulated AF signal or 12 kHz IF signal.
- Remotely controlling using optional RS-BA1 software (compatible in the near future).
- Gateway communication (D-STAR)
- Data communication (DD mode)
- Picture transferring from a PC or a mobile device.

① You can select the output signal from AF and IF signals.

**MENU** » **SET > Connectors > LAN AF/IF Output**

**About the LED indication**① **LINK/ACT**

- Lights green when a cable is connected.
- Does not light when a cable is not connected.
- Blinks green while communicating.

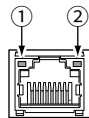
② **Speed**

- Lights green while communicating in 100BASE-TX.
- Does not light while communicating in 10BASE-T, or when a cable is not connected.

## ◇ [RF UNIT]

Connects to the RF unit with a supplied control cable.

**About the LED indication**① **LINK/ACT**

- Lights green when a cable is connected.
- Does not light when a cable is not connected.
- Blinks yellow while communicating.

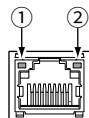

- ② • Lights orange the RF unit is connected.
- Does not light when the RF unit is not connected.

## ◇ [USB]

Use the USB Type-C port for:

- Outputting decoded RTTY data.
- Outputting a demodulated AF signal or 12 kHz IF signal.
- Inputting an AF modulation signal.
- Inputting weather data for weather station transmission.
- Interface for remote control using CI-V commands.
- Cloning setting data using the CS-905 software.
- Remotely controlling using optional RS-BA1 software (compatible in the near future).
- Using the External Gateway function.

① You can change the signal output type and output level.

**MENU** » **SET > Connectors > USB/AV-OUT AF/IF Output**

You can download the USB driver and installation guide from the Icom website.

<https://www.icomjapan.com/support/>

## RF unit

### ◇ [ACC]

Connects to devices to control an external unit or to control the transceiver.

① **DO NOT** connect anything to NC pins.

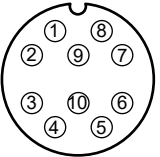
ACC	Pin No.	Name	Description	Specifications	
 <p>10-pin Bottom panel view</p>	1	NC	–	–	
	2	NC	–	–	
	3	GND	Connects to ground.	–	
	4	NC	–	–	
	5	NC	–	–	
	6	NC	–	–	
	7	ALC	ALC voltage input.	Input impedance: More than 10 kΩ Input level: –4 ~ 0 V Input voltage: Less than 30 V Input current: Less than 0.5 mA	
	8	GND	Connects to ground.	–	
	9	SEND	Input/output pin.	An external unit controls the transceiver. When this pin goes to ground, the transceiver transmits. The pin goes low when the transceiver transmits.	Voltage: Less than 30 V (Reverse voltage: 80 V) Open circuit voltage: 5 V Voltage (TX): –0.5 ~ +0.8 V Current flow: Maximum 2.27 mA
	10	NC	–	–	

### When connecting an external unit

When connecting an external unit, use a supplied accessory connector.

① Usable cable diameter: 4.5 ~ 6.5 mm (0.2 ~ 0.3 in)

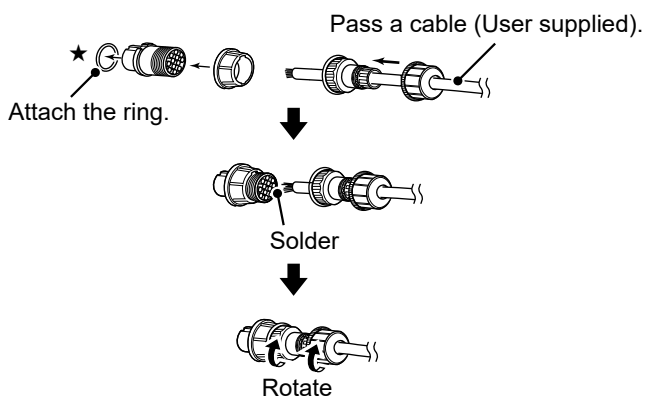

**NOTE:** Attach the ring (★). Otherwise the dust-protection and water jet resistance cannot be guaranteed.

## RF unit

## ◇ [REF OUT 10 MHz/-10 dBm]

Outputs a 10 MHz signal as a reference frequency signal.



Type BNC

- Output frequency: 10 MHz
- Output impedance: 50  $\Omega$  (unbalanced)
- Output level: -10 dBm (approximate)

## ◇ [GPS ANT]

Connect a supplied GPS antenna.



Type SMA

- Input impedance: 50  $\Omega$  (unbalanced)
- Output voltage: 3.3 V

## ◇ [144/430/1200 MHz ANT]

Connect an antenna for the 144 MHz, 430 MHz, and 1200 MHz bands.

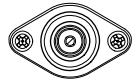

Type N

- Input/Output impedance: 50  $\Omega$  (unbalanced)

## ◇ [2400 MHz ANT]

Connect an antenna for the 2400 MHz band.



Type SMA

- Input/Output impedance: 50  $\Omega$  (unbalanced)

## ◇ [5600 MHz ANT]

Connect an antenna for the 5600 MHz band.



Type SMA

- Input/Output impedance: 50  $\Omega$  (unbalanced)

# INSTALLATION NOTES

For amateur base station installations it is recommended that the forward clearance in front of the antenna array is calculated relative to the EIRP (Effective Isotropic Radiated Power). The clearance height below the antenna array can be determined in most cases from the RF power at the antenna input terminals.

As different exposure limits have been recommended for different frequencies, a relative table shows a guideline for installation considerations.

Below 30 MHz, the recommended limits are specified in terms of V/m or A/m fields as they are likely to fall within the near-field region. Similarly, the antennas may be physically short in terms of electrical length and that the installation will require some antenna matching device which can create local, high intensity magnetic fields. Analysis of such MF installations is best considered in association with published guidance notes such as the FCC OET Bulletin 65 Edition 97-01 and its annexes relative to amateur transmitter installations. The EC recommended limits are almost identical to the FCC specified 'uncontrolled' limits and tables exist that show pre-calculated safe distances for different antenna types for different frequency bands. Further information can be found at <http://www.arrl.org/>.

• **Typical amateur radio installation**

Exposure distance assumes that the predominant radiation pattern is forward and that radiation vertically downwards is at unity gain (sidelobe suppression is equal to main lobe gain). This is true of almost every gain antenna today.

Exposed persons are assumed to be beneath the antenna array and have a typical height of 1.8 m.

The figures assume the worst case emission of a constant carrier.

For the bands 10 MHz and higher the following power density limits have been recommended:

- 10–400 MHz      2 W/sq m
- 435 MHz        2.2 W/sq m

**EIRP clearance heights by frequency band**

Watts	10–2 m	70 cm	23 cm	13 cm and beyond
1	2.1 m	2 m	2 m	2 m
10	2.8 m	2.7 m	2.5 m	2.3 m
25	3.4 m	3.3 m	2.7 m	2.5 m
100	5 m	4.7 m	3.6 m	3.2 m
1000	12 m	11.5 m	7.3 m	6.3 m

**Forward clearance, EIRP by frequency band**

Watts	10–2 m	70 cm	23 cm	13 cm and beyond
100	2 m	2 m	1.1 m	0.7 m
1,000	6.5 m	6 m	3.5 m	3 m
10,000	20 m	18 m	11 m	7 m
100,000	65 m	60 m	35 m	29 m

In all cases any possible risk depends on the transmitter being activated for long periods. (actual recommendation limits are specified as an average during 6 minutes)

Normally the transmitter is not active for long periods of time. Some radio licenses will require that a timer circuit automatically cuts the transmitter after 1–2 minutes etc.

Similarly some types of emission, i.e., SSB, CW, AM etc. have a lower 'average' output power and the assessed risk is even lower.

1/4 Tuning function ..... 3-4  
 1 MHz Step Tuning function ..... 3-3

**A**

AFC function ..... 4-3  
 AGC function ..... 4-4  
 All reset ..... 10-2  
 Attenuator ..... 4-1  
 Audio scope ..... 5-3  
 Auto Power OFF ..... 8-3  
 Auto Tuning Step function ..... 3-4

**B**

Band Edge ..... 3-6  
 Band Edge Beep ..... 3-6, 8-2  
 Band Stacking Register ..... 3-2  
 Break-in function ..... 4-13

**C**

Call channel mode ..... 3-1  
 Cleaning ..... 10-1  
 Clock  
     Current time ..... 9-1  
     Date ..... 9-1  
     UTC offset ..... 9-1  
 Connectors (Set mode) ..... 8-14  
 CW  
     Pitch control ..... 4-12  
     Side tone ..... 4-13

**D**

Data mode ..... 3-2  
 DC power supply ..... 2-2  
 Dial Lock function ..... 3-8  
 Digital Twin PBT ..... 4-5  
 Display ..... 1-5  
 Display (Set mode) ..... 8-18  
 DV/DD Set (Set mode) ..... 8-9

**E**

Electronic Keyer function ..... 4-14  
 Entering and editing ..... vii

**F**

Filter  
     IF filter ..... 4-6  
     Notch Filter ..... 4-7  
     Transmit filter width ..... 4-9  
 Fine Tuning function ..... 3-3  
 Frequency  
     Directly entering ..... 3-4  
     Using the Main Dial ..... 3-3  
 Function (Set mode) ..... 8-2  
 Fuse ..... 10-1

**G**

GPS ..... 7-1

**K**

Keyboard  
     Entering and editing ..... vii  
     Keyboard type ..... vii, 8-6

**M**

Memory mode ..... 3-1  
 MENU screen ..... 1-7  
 Meter ..... 3-10

Microphone gain ..... 3-9  
 Microphone plate ..... 2-1  
 Monitor function ..... 4-2  
 Multi-function dial ..... 1-8  
 Multi-function menu ..... 1-8  
 My Station (Set mode) ..... 8-6

**N**

Network (Set mode) ..... 8-16  
 Noise Blanker ..... 4-8  
 Noise Reduction ..... 4-9  
 Noise squelch ..... 3-9  
 NTP Function ..... 8-21

**O**

Operating band ..... 3-2  
 Operating mode ..... 3-2  
 Options ..... 12-1  
 Oscilloscope ..... 5-3  
 Others (Set mode) ..... 8-22

**P**

Partial reset ..... 10-2  
 Power ON or OFF ..... 3-1  
 Preamplifiers ..... 4-1

**Q**

QSO/RX Log (Set mode) ..... 8-11  
 QUICK MENU ..... 1-7  
 Quick Split function ..... 4-11, 8-3

**R**

Resetting ..... 10-1  
 RF gain ..... 3-9  
 RIT function ..... 4-2

**S**

SD card ..... 6-1  
 SD Card (Set mode) ..... 8-21  
 S-meter squelch ..... 3-9  
 Spectrum scope  
     Center mode ..... 5-2  
     Fixed mode ..... 5-2  
     Marker ..... 5-2  
     Mini scope screen ..... 5-3  
     Scroll mode ..... 5-2  
 Speech Compressor ..... 4-10  
 Split frequency operation ..... 4-11  
 Split Lock function ..... 4-12, 8-3  
 SQL level ..... 3-9  
 Squelch ..... 3-9

**T**

Time Set (Set mode) ..... 8-21  
 Tone Control/TBW (Set mode) ..... 8-2  
 Transmit output power ..... 3-11  
 Troubleshooting ..... 10-3  
 Tuning Step function ..... 3-3  
 TX PWR LIMIT ..... 3-11

**V**

VFO mode ..... 3-1  
 Volume level ..... 3-1

# ABOUT THE LICENSES

Information on the open source software being used by this product.

## **COPYRIGHT NOTICE, DISCLAIMER, and LICENSE:**

If you modify libpng you may insert additional notices immediately following this sentence.

This code is released under the libpng license.

libpng versions 1.2.6, August 15, 2004, through 1.6.12, June 12, 2014, are Copyright (c) 2004, 2006-2014 Glenn Randers-Pehrson, and are distributed according to the same disclaimer and license as libpng-1.2.5 with the following individual added to the list of Contributing Authors:

Cosmin Truta

libpng versions 1.0.7, July 1, 2000, through 1.2.5, October 3, 2002, are Copyright (c) 2000-2002 Glenn Randers-Pehrson, and are distributed according to the same disclaimer and license as libpng-1.0.6 with the following individuals added to the list of Contributing Authors:

Simon-Pierre Cadieux  
Eric S. Raymond  
Gilles Vollant

and with the following additions to the disclaimer:

There is no warranty against interference with your enjoyment of the library or against infringement. There is no warranty that our efforts or the library will fulfill any of your particular purposes or needs. This library is provided with all faults, and the entire risk of satisfactory quality, performance, accuracy, and effort is with the user.

libpng versions 0.97, January 1998, through 1.0.6, March 20, 2000, are Copyright (c) 1998, 1999, 2000 Glenn Randers-Pehrson, and are distributed according to the same disclaimer and license as libpng-0.96, with the following individuals added to the list of Contributing Authors:

Tom Lane  
Glenn Randers-Pehrson  
Willem van Schaik

libpng versions 0.89, June 1996, through 0.96, May 1997, are Copyright (c) 1996, 1997 Andreas Dilger Distributed according to the same disclaimer and license as libpng-0.88, with the following individuals added to the list of Contributing Authors:

John Bowler  
Kevin Bracey  
Sam Bushell  
Magnus Holmgren  
Greg Roelofs  
Tom Tanner

libpng versions 0.5, May 1995, through 0.88, January 1996, are Copyright (c) 1995, 1996 Guy Eric Schalnat, Group 42, Inc.

For the purposes of this copyright and license, "Contributing Authors" is defined as the following set of individuals:

Andreas Dilger  
Dave Martindale  
Guy Eric Schalnat  
Paul Schmidt  
Tim Wegner

The PNG Reference Library is supplied "AS IS". The Contributing Authors and Group 42, Inc. disclaim all warranties, expressed or implied, including, without limitation, the warranties of merchantability and of fitness for any purpose. The Contributing Authors and Group 42, Inc. assume no liability for direct, indirect, incidental, special, exemplary, or consequential damages, which may result from the use of the PNG Reference Library, even if advised of the possibility of such damage.

Permission is hereby granted to use, copy, modify, and distribute this source code, or portions hereof, for any purpose, without fee, subject to the following restrictions:

1. The origin of this source code must not be misrepresented.
2. Altered versions must be plainly marked as such and must not be misrepresented as being the original source.
3. This Copyright notice may not be removed or altered from any source or altered source distribution.

The Contributing Authors and Group 42, Inc. specifically permit, without fee, and encourage the use of this source code as a component to supporting the PNG file format in commercial products. If you use this source code in a product, acknowledgment is not required but would be appreciated.

A "png\_get\_copyright" function is available, for convenient use in "about" boxes and the like:

```
printf("%s", png_get_copyright(NULL));
```

Also, the PNG logo (in PNG format, of course) is supplied in the files "pngbar.png" and "pngbar.jpg (88x31)" and "pngnow.png" (98x31).

Libpng is OSI Certified Open Source Software. OSI Certified is a certification mark of the Open Source Initiative.

The contributing authors would like to thank all those who helped with testing, bug fixes, and patience. This wouldn't have been possible without all of you.

Thanks to Frank J. T. Wojcik for helping with the documentation.

## **License for CMSIS-RTOS RTX Implementation**

Copyright (c) 1999-2009 KEIL, 2009-2013 ARM Germany GmbH All rights reserved.

Redistribution and use in source and binary forms, with or without modification, are permitted provided that the following conditions are met:

- Redistributions of source code must retain the above copyright notice, this list of conditions and the following disclaimer.
- Redistributions in binary form must reproduce the above copyright notice, this list of conditions and the following disclaimer in the documentation and/or other materials provided with the distribution.
- Neither the name of ARM nor the names of its contributors may be used to endorse or promote products derived from this software without specific prior written permission.

THIS SOFTWARE IS PROVIDED BY THE COPYRIGHT HOLDERS AND CONTRIBUTORS "AS IS" AND ANY EXPRESS OR IMPLIED WARRANTIES, INCLUDING, BUT NOT LIMITED TO, THE IMPLIED WARRANTIES OF MERCHANTABILITY AND FITNESS FOR A PARTICULAR PURPOSE ARE DISCLAIMED. IN NO EVENT SHALL COPYRIGHT HOLDERS AND CONTRIBUTORS BE LIABLE FOR ANY DIRECT, INDIRECT, INCIDENTAL, SPECIAL, EXEMPLARY, OR CONSEQUENTIAL DAMAGES (INCLUDING, BUT NOT LIMITED TO, PROCUREMENT OF SUBSTITUTE GOODS OR SERVICES; LOSS OF USE, DATA, OR PROFITS; OR BUSINESS

INTERRUPTION) HOWEVER CAUSED AND ON ANY THEORY OF LIABILITY, WHETHER IN CONTRACT, STRICT LIABILITY, OR TORT (INCLUDING NEGLIGENCE OR OTHERWISE) ARISING IN ANY WAY OUT OF THE USE OF THIS SOFTWARE, EVEN IF ADVISED OF THE POSSIBILITY OF SUCH DAMAGE.

## **ZLIB DATA COMPRESSION LIBRARY**

zlib 1.2.8 is a general purpose data compression library. All the code is thread safe. The data format used by the zlib library is described by RFCs (Request for Comments) 1950 to 1952 in the files <http://tools.ietf.org/html/rfc1950> (zlib format), [rfc1951](http://tools.ietf.org/html/rfc1951) (deflate format) and [rfc1952](http://tools.ietf.org/html/rfc1952) (gzip format).

All functions of the compression library are documented in the file `zlib.h` (volunteer to write man pages welcome, contact [zlib@gzip.org](mailto:zlib@gzip.org)). A usage example of the library is given in the file `test/example.c` which also tests that the library is working correctly. Another example is given in the file `test/minigzip.c`. The compression library itself is composed of all source files in the root directory.

To compile all files and run the test program, follow the instructions given at the top of `Makefile.in`. In short ".configure; make test", and if that goes well, "make install" should work for most flavors of Unix. For Windows, use one of the special makefiles in `win32/` or `contrib/vstudio/`. For VMS, use `make_vms.com`.

Questions about zlib should be sent to [zlib@gzip.org](mailto:zlib@gzip.org), or to Gilles Vollant [info@winimage.com](mailto:info@winimage.com) for the Windows DLL version. The zlib home page is <http://zlib.net/>. Before reporting a problem, please check this site to verify that you have the latest version of zlib; otherwise get the latest version and check whether the problem still exists or not.

PLEASE read the zlib FAQ [http://zlib.net/zlib\\_faq.html](http://zlib.net/zlib_faq.html) before asking for help.

Mark Nelson [markn@jeee.org](mailto:markn@jeee.org) wrote an article about zlib for the Jan. 1997 issue of Dr. Dobbs's Journal; a copy of the article is available at <http://marknelson.us/1997/01/01/zlib-engine/>.

The changes made in version 1.2.8 are documented in the file `ChangeLog`.

Unsupported third party contributions are provided in directory `contrib/`.

Zlib is available in Java using the `java.util.zip` package, documented at <http://java.sun.com/developer/technicalArticles/Programming/compression/>.

A Perl interface to zlib written by Paul Marquess [pmqs@cpan.org](mailto:pmqs@cpan.org) is available at CPAN (Comprehensive Perl Archive Network) sites, including <http://search.cpan.org/~pmqs/IO-Compress-Zlib/>.

A Python interface to zlib written by A.M.Kuchling [amk@amk.ca](mailto:amk@amk.ca) is available in Python 1.5 and later versions, see <http://docs.python.org/library/zlib.html>.

zlib is built into tcl: <http://wiki.tcl.tk/4610>.

An experimental package to read and write files in `.zip` format, written on top of zlib by Gilles Vollant [info@winimage.com](mailto:info@winimage.com), is available in the `contrib/minizip` directory of zlib.

Notes for some targets:

- For Windows DLL versions, please see `win32/DLL_FAQ.txt`
- For 64-bit Irix, `deflate.c` must be compiled without any optimization. With `-O`, one libpng test fails. The test works in 32 bit

mode (with the `-n32` compiler flag). The compiler bug has been reported to SGI.

- zlib doesn't work with gcc 2.6.3 on a DEC 3000/300LX under OSF/1 2.1 it works when compiled with cc.

- On Digital Unix 4.0D (formerly OSF/1) on AlphaServer, the `cc` option `-std1` is necessary to get `gzprintf` working correctly. This is done by `configure`.

- zlib doesn't work on HP-UX 9.05 with some versions of `/bin/cc`. It works with other compilers. Use "make test" to check your compiler.

- `gzopen` is not supported on RISCOS or BEOS.

- For PalmOS, see <http://palmzlib.sourceforge.net/>

## **Acknowledgments:**

The deflate format used by zlib was defined by Phil Katz. The deflate and zlib specifications were written by L. Peter Deutsch. Thanks to all the people who reported problems and suggested various improvements in zlib; they are too numerous to cite here.

## **Copyright notice:**

(C) 1995-2013 Jean-loup Gailly and Mark Adler

This software is provided 'as-is', without any express or implied warranty. In no event will the authors be held liable for any damages arising from the use of this software.

Permission is granted to anyone to use this software for any purpose, including commercial applications, and to alter it and redistribute it freely, subject to the following restrictions:

1. The origin of this software must not be misrepresented; you must not claim that you wrote the original software. If you use this software in a product, an acknowledgment in the product documentation would be appreciated but is not required.
2. Altered source versions must be plainly marked as such, and must not be misrepresented as being the original software.
3. This notice may not be removed or altered from any source distribution.

Jean-loup Gailly Mark Adler  
[jloop@gzip.org](mailto:jloop@gzip.org) [madler@alumni.caltech.edu](mailto:madler@alumni.caltech.edu)

If you use the zlib library in a product, we would appreciate "not" receiving lengthy legal documents to sign. The sources are provided for free but without warranty of any kind. The library has been entirely written by Jean-loup Gailly and Mark Adler; it does not include third-party code.

If you redistribute modified sources, we would appreciate that you include in the file `ChangeLog` history information documenting your changes. Please read the FAQ for more information on the distribution of modified source versions.

## mbed TLS

### Apache License

Version 2.0, January 2004

<http://www.apache.org/licenses/>

### TERMS AND CONDITIONS FOR USE, REPRODUCTION, AND DISTRIBUTION

#### 1. Definitions.

"License" shall mean the terms and conditions for use, reproduction, and distribution as defined by Sections 1 through 9 of this document.

"Licensor" shall mean the copyright owner or entity authorized by the copyright owner that is granting the License.

"Legal Entity" shall mean the union of the acting entity and all other entities that control, are controlled by, or are under common control with that entity. For the purposes of this definition, "control" means (i) the power, direct or indirect, to cause the direction or management of such entity, whether by contract or otherwise, or (ii) ownership of fifty percent (50%) or more of the outstanding shares, or (iii) beneficial ownership of such entity.

"You" (or "Your") shall mean an individual or Legal Entity exercising permissions granted by this License.

"Source" form shall mean the preferred form for making modifications, including but not limited to software source code, documentation source, and configuration files.

"Object" form shall mean any form resulting from mechanical transformation or translation of a Source form, including but not limited to compiled object code, generated documentation, and conversions to other media types.

"Work" shall mean the work of authorship, whether in Source or Object form, made available under the License, as indicated by a copyright notice that is included in or attached to the work (an example is provided in the Appendix below).

"Derivative Works" shall mean any work, whether in Source or Object form, that is based on (or derived from) the Work and for which the editorial revisions, annotations, elaborations, or other modifications represent, as a whole, an original work of authorship. For the purposes of this License, Derivative Works shall not include works that remain separable from, or merely link (or bind by name) to the interfaces of, the Work and Derivative Works thereof.

"Contribution" shall mean any work of authorship, including the original version of the Work and any modifications or additions to that Work or Derivative Works thereof, that is intentionally submitted to Licensor for inclusion in the Work by the copyright owner or by an individual or Legal Entity authorized to submit on behalf of the copyright owner. For the purposes of this definition, "submitted" means any form of electronic, verbal, or written communication sent to the Licensor or its

representatives, including but not limited to communication on electronic mailing lists, source code control systems, and issue tracking systems that are managed by, or on behalf of, the Licensor for the purpose of discussing and improving the Work, but excluding communication that is conspicuously marked or otherwise designated in writing by the copyright owner as "Not a Contribution."

"Contributor" shall mean Licensor and any individual or Legal Entity on behalf of whom a Contribution has been received by Licensor and subsequently incorporated within the Work.

2. Grant of Copyright License. Subject to the terms and conditions of this License, each Contributor hereby grants to You a perpetual, worldwide, non-exclusive, no-charge, royalty-free, irrevocable copyright license to reproduce, prepare Derivative Works of, publicly display, publicly perform, sublicense, and distribute the Work and such Derivative Works in Source or Object form.
3. Grant of Patent License. Subject to the terms and conditions of this License, each Contributor hereby grants to You a perpetual, worldwide, non-exclusive, no-charge, royalty-free, irrevocable (except as stated in this section) patent license to make, have made, use, offer to sell, sell, import, and otherwise transfer the Work, where such license applies only to those patent claims licensable by such Contributor that are necessarily infringed by their Contribution(s) alone or by combination of their Contribution(s) with the Work to which such Contribution(s) was submitted. If You institute patent litigation against any entity (including a cross-claim or counterclaim in a lawsuit) alleging that the Work or a Contribution incorporated within the Work constitutes direct or contributory patent infringement, then any patent licenses granted to You under this License for that Work shall terminate as of the date such litigation is filed.
4. Redistribution. You may reproduce and distribute copies of the Work or Derivative Works thereof in any medium, with or without modifications, and in Source or Object form, provided that You meet the following conditions:
  - (a) You must give any other recipients of the Work or Derivative Works a copy of this License; and
  - (b) You must cause any modified files to carry prominent notices stating that You changed the files; and
  - (c) You must retain, in the Source form of any Derivative Works that You distribute, all copyright, patent, trademark, and attribution notices from the Source form of the Work, excluding those notices that do not pertain to any part of the Derivative Works; and
  - (d) If the Work includes a "NOTICE" text file as part of its distribution, then any Derivative Works that You distribute must include a readable copy of the attribution notices contained within such NOTICE file, excluding those notices that do not pertain to any part of the Derivative Works, in at least one of the following places: within a

NOTICE text file distributed as part of the Derivative Works; within the Source form or documentation, if provided along with the Derivative Works; or, within a display generated by the Derivative Works, if and wherever such third-party notices normally appear. The contents of the NOTICE file are for informational purposes only and do not modify the License. You may add Your own attribution notices within Derivative Works that You distribute, alongside or as an addendum to the NOTICE text from the Work, provided that such additional attribution notices cannot be construed as modifying the License.

You may add Your own copyright statement to Your modifications and may provide additional or different license terms and conditions for use, reproduction, or distribution of Your modifications, or for any such Derivative Works as a whole, provided Your use, reproduction, and distribution of the Work otherwise complies with the conditions stated in this License.

5. Submission of Contributions. Unless You explicitly state otherwise, any Contribution intentionally submitted for inclusion in the Work by You to the Licensor shall be under the terms and conditions of this License, without any additional terms or conditions. Notwithstanding the above, nothing herein shall supersede or modify the terms of any separate license agreement you may have executed with Licensor regarding such Contributions.
6. Trademarks. This License does not grant permission to use the trade names, trademarks, service marks, or product names of the Licensor, except as required for reasonable and customary use in describing the origin of the Work and reproducing the content of the NOTICE file.
7. Disclaimer of Warranty. Unless required by applicable law or agreed to in writing, Licensor provides the Work (and each Contributor provides its Contributions) on an "AS IS" BASIS, WITHOUT WARRANTIES OR CONDITIONS OF ANY KIND, either express or implied, including, without limitation, any warranties or conditions of TITLE, NON-INFRINGEMENT, MERCHANTABILITY, or FITNESS FOR A PARTICULAR PURPOSE. You are solely responsible for determining the appropriateness of using or redistributing the Work and assume any risks associated with Your exercise of permissions under this License.
8. Limitation of Liability. In no event and under no legal theory, whether in tort (including negligence), contract, or otherwise, unless required by applicable law (such as deliberate and grossly negligent acts) or agreed to in writing, shall any Contributor be liable to You for damages, including any direct, indirect, special, incidental, or consequential damages of any character arising as a result of this License or out of the use or inability to use the Work (including but not limited to damages for loss of goodwill, work stoppage, computer failure or malfunction, or any and all other commercial damages or

losses), even if such Contributor has been advised of the possibility of such damages.

9. Accepting Warranty or Additional Liability. While redistributing the Work or Derivative Works thereof, You may choose to offer, and charge a fee for, acceptance of support, warranty, indemnity, or other liability obligations and/or rights consistent with this License. However, in accepting such obligations, You may act only on Your own behalf and on Your sole responsibility, not on behalf of any other Contributor, and only if You agree to indemnify, defend, and hold each Contributor harmless for any liability incurred by, or claims asserted against, such Contributor by reason of your accepting any such warranty or additional liability.

#### END OF TERMS AND CONDITIONS

APPENDIX: How to apply the Apache License to your work.

To apply the Apache License to your work, attach the following boilerplate notice, with the fields enclosed by brackets "[]" replaced with your own identifying information. (Don't include the brackets!) The text should be enclosed in the appropriate comment syntax for the file format. We also recommend that a file or class name and description of purpose be included on the same "printed page" as the copyright notice for easier identification within third-party archives.

Copyright 2016, Arthur Teplitzki 2013, Edmodo, Inc.

Licensed under the Apache License, Version 2.0 (the "License");

you may not use this file except in compliance with the License.

You may obtain a copy of the License at

<http://www.apache.org/licenses/LICENSE-2.0>

Unless required by applicable law or agreed to in writing, software distributed under the License is distributed on an "AS IS" BASIS, WITHOUT WARRANTIES OR CONDITIONS OF ANY KIND, either express or implied.

See the License for the specific language governing permissions and limitations under the License.

