

Trinidad II

MODEL SBE-30CB



SERVICE MANUAL

SBE

®

TABLE OF CONTENTS

1. GENERAL

- 1.1 Customer Service 1
- 1.2 Parts Orders 1
- 1.3 Factory Returns 1

2. SPECIFICATIONS

- 2.1 General 2
- 2.2 Receiver 2
- 2.3 Transmitter 3

3. INSTALLATION

- 3.1 Installation
- 3.2 Antenna Tuning
- 3.3 Accessories
- 3.4 Final Checkout

4. CIRCUIT DESCRIPTION

- 4.1 Introduction 6
- 4.2 Receiver 6
- 4.3 Transmitter 8

5. SERVICING

- 5.1 Introduction 10
- 5.2 Test Signals 10
- 5.3 Troubleshooting 11

6. PARTS LIST 22

BACK POCKET:

SCHEMATIC DIAGRAM
SERVICE BULLETINS

ILLUSTRATIONS

- 4-1 SBE-30CB Transceiver Block Diagram 9
- 5-1 Performance Verification Procedure 12
- 5-2 Recommended Test Instruments 13
- 5-3 SBE-30CB Synthesizer Mixing Scheme 14
- 5-4 Transmitter Test Connection 15
- 5-5 Receiver Test Connection 15
- 5-6 Receiver Alignment Procedure 16
- 5-7 AGC Voltages versus RF Input Level 16
- 5-8 Alignment Layout 17
- 5-9 Receiver Injection Voltages 17
- 5-10 Transmitter Alignment Procedure 18
- 5-11 Transmitter Alignment Waveforms 19
- 5-12 Modulation Waveforms 20
- 5-13 Component Layout 21

SUBJECT	NUMBER

SECTION 1 GENERAL

1.1 CUSTOMER SERVICE

The SBE Technical Services Department functions as a source of information on the application, installation and use of SBE products. In addition, the Technical Services Department provides technical consultation on service problems and availability of local and factory repair facilities.

In any communications to the Technical Services Department, please include a complete description of your problems or needs, including model and serial numbers of the unit or units in question, accessories being used, any modifications or attachments in use, or any non-standard installation details.

For assistance on any of the above matters, please contact SBE, Incorporated, Technical Services Department, 220 Airport Boulevard, Watsonville, California 95076. Phone: 408/722-4177.

1.2 PARTS ORDERS

SBE original replacement parts are available from the Factory Parts Department at 1045 Main Street, Watsonville, California 95076.

When ordering parts, please supply the following information:

Model number of the unit.
Serial number of the unit.
Part number.
Description of the part.

1.3 FACTORY RETURNS

Repair services are available locally through SBE Certified Service Stations across the country. A list of these Service Stations is available upon request from the Technical Services Department. Do not return any merchandise to the Factory without authorization from the Factory.

SECTION 2
SPECIFICATIONS

2.1 GENERAL

Compliance	F.C.C. Type Accepted (Part 95, Class D)
Channels	23
Frequency Range	(26.965 - 27.255) MHz
Frequency Control	Crystals, Synthesized
Frequency Tolerance	±0.003%
Operating Temperature Range	-30°C to +50°C
Humidity	95%
Input Voltage	120 VAC or (11.7 - 15.9) VDC positive or negative ground
Microphone	Dynamic
Size	Height: 2" (53mm) Width: 6¼" (160mm) Depth: 7-7/8" (200mm)
Weight	3 lbs., 1.36 Kg.
Power Consumption	40 watts, Full Modulation
Fuse	2A fast blow (Type 3AG or A.G.C.)

2.2 RECEIVER

Sensitivity	0.7μV for 10db S+N/N
Selectivity	-6db @ ±6 KHz, -50db @ ±10 KHz
IF Frequency	10 MHz, 455 KHz
AGC Response	Less than 10db for 10-100,000μV
Squelch Threshold	Less than 1μV
Audio Power Output	2 watts
External Speaker	(Not Supplied) 4 or 8Ω. Disables internal speaker when connected.
Squelch Range	200μV (Minimum)

2.3 TRANSMITTER

Power Output	4 watts
Modulation	95-100%
Modulator Response	300-2500 Hz
Output Impedance	50 Ω , unbalanced
Emission	6A3

SECTION 3 INSTALLATION

3.1 GENERAL

The first step in the installation of the SBE-30CB is to select a site which is convenient and permits accessibility to a good antenna location. The selection of an antenna system and its mounting location are the most critical factors in determining performance.

A vertical ground plane antenna will provide the most uniform horizontal coverage. This type of antenna is best suited for communications with a mobile unit. For point-to-point operation where both stations are fixed, a directional beam antenna will usually increase communication range since this type of antenna concentrates energy in one direction. Beam antennas also allow the receiver to "listen" in only one direction thus reducing interfering signals. F.C.C. regulations limit antenna height of directionals to 20 feet above ground or any formation and omnidirectionals and supporting structure to 60 feet above ground.

3.2 ANTENNA TUNING

The final step in installation is to trim the antenna for minimum S.W.R. The recommended method of antenna tuning is to use an in-line wattmeter or S.W.R. bridge to adjust the antenna for minimum reflected power on channel 11. A properly tuned antenna system will present a suitable load to the transceiver and will insure that maximum power is transferred from the radio to the antenna. If the antenna system in use presents a poor load, as indicated by a high S.W.R. reading, transmitter range will be substantially reduced and damage to the transmitter final amplifier may occur. Poor S.W.R. can usually be corrected by altering the antenna's electrical length in accordance with the manufacturer's instruction. Extremely high S.W.R. readings may be indicative of a defective transmission line, antenna, or connections.

To determine whether the antenna should be lengthened or shortened, test the S.W.R. on channels 1 and 23. If the S.W.R. is the highest on channel 23, the antenna is too long and if highest on channel 1, the antenna is too short. When the antenna system has been tuned correctly, channel 11 should have the lowest S.W.R. and channels 1 and 23 will be slightly higher.

3.3 ACCESSORIES

EMERGENCY DC POWER

If it is anticipated that the unit may be used in the event of a power failure, a 12 volt storage battery may be connected to the terminal strip on the rear panel. Connect the negative and positive battery terminals to the corresponding points on the terminal strip using #14 or larger wire. In the event of AC power failure, the unit will automatically draw primary power from the battery source. When AC power is restored, the unit will automatically return to normal AC operation. It is not necessary to disconnect the emergency DC power source when the AC line is being used. It is recommended that a means to keep the storage battery fully charged be provided.

PUBLIC ADDRESS

An external 8 Ω 4 watt speaker may be connected to the PA jack located on the rear panel of the unit when it is to be used as a public address system. The speaker should be directed away from the microphone to prevent acoustical feedback.

EXTERNAL SPEAKER

The external speaker jack on the rear panel is used for remote receiver monitoring. The external speaker may be 4 or 8 Ω impedance and should be rated at 3 watts power dissipation. When the external speaker is plugged in, the internal speaker is disconnected. Suitable units are the model SBE-1SP Non-amplified speaker or SBE-1SP/AMP Amplified speaker.

ALTERNATE MICROPHONE INSTALLATION

A desk microphone may be installed with the unit. For best results, a low impedance dynamic type microphone or a transistorized preamplified microphone is recommended. The SBE 100X Preamplified Base Station Microphone or the SBE 200X Non-amplified Base Station Microphone may be ordered and are ready to plug into the unit. If another microphone is selected refer to the schematic diagram for the proper wiring connections to the microphone jack.

3.4 FINAL CHECKOUT

Make an operational checkout of the transceiver to insure operation of it and all the accessories installed. Contact other stations and inquire about their location and their reception of your signal. If an omnidirectional antenna is used, the distance to other stations contacted should be about the same in all directions. A directional antenna should reach more distant stations in the direction in which it is beamed. Also inquire whether the stations contacted are omnidirectional or directional and if directional which way they are beamed.

SECTION 4

CIRCUIT DESCRIPTION

4.1 INTRODUCTION

The SBE-30CB is an AM transceiver with a dual-conversion receiver using intermediate frequencies of 10 MHz and 455 KHz.

Refer to the block and schematic diagrams while following the circuit description.

TRANSMIT MODE is initiated by pressing the push-to-talk switch which energizes relay RL-1 which:

DISABLES:

- RX RF AMP (Q4),
- 1st RX MIXER (Q5),
- 2nd RX MIXER (Q6),
- 1st IF AMP (Q7),
- 2nd IF AMP (Q8),
- RX OSCILLATOR (Q1),
- 1st RX AUDIO (Q9),
- SPEAKER SP-1,

ENABLES:

- TX OSCILLATOR (Q3),
- TX MIXER (Q15),
- RX PROTECTION DIODE (D1).

When the push-to-talk switch is released, the transceiver is in RECEIVE MODE and the above states are reversed.

4.2 RECEIVER

In receive mode, an RF signal is fed from the antenna to the RF AMP (Q4). The amplified RF signal is then fed to Q5 – the 1st mixer – where it is mixed with an injection signal from the MASTER OSCILLATOR Q2 about 10 MHz below the receive channel frequency. The resultant 10 MHz 1st IF is selected by L1 and L2 and fed to Q6 – the 2nd mixer – where it is mixed with an injection signal from the RX OSCILLATOR Q1 455 KHz below the 10 MHz 1st IF. The ceramic filter FL-1 selects the 455 KHz signal and feeds it to the 1st IF AMP Q7 which then feeds it to the 2nd IF AMP Q8. The output of Q8 is fed through C24 to the AGC detection diodes D3 and D4, through C85 to the S METER detection diodes D15 and D16, and through C22 to the audio detection diodes D5 and D6. After passing through the AUTOMATIC NOISE LIMITER, the detected audio signal is applied across potentiometer VR1 – the volume control. The audio signal developed on the VR1 wiper is then fed to audio amplifier stage Q10 which then feeds Q11. The output of Q11 drives Q12 which is transformer coupled to push-pull speaker driver amplifier Q13 and Q14.

AUTOMATIC GAIN CONTROL CIRCUIT

The AGC (Automatic Gain Control) on the SBE-30CB reduces the gain of the receiver in response to a strong signal by lowering the bias on the RF and IF amplifiers.¹ The AGC voltage is developed at the R2, R19 junction and filtered by C25. With a weak receiver input signal – less than 1 μ V – diodes D3

and D4 are forward biased by current through R2, R27, R28 and R19. About 1.5 volts of AGC appear at the C25, R19 junction. As the input signal increases, the signal at the top of C24 increases. When the signal at the top of C24 swings negative, current flows through D3 on to C24. As the signal swings positive, C24 discharges through D4. The increase in current through R2, R27, R28 decreases the AGC voltage. The AGC voltage is then fed through R1 and the secondary of T1 to the base of Q4, through R5 and the secondary of T2 to the base of Q5, through R19 and L2 to the base of Q6, and through R12 to the base of Q7.

THE AUDIO DETECTOR

The AUDIO DETECTOR on the SBE-30CB demodulates the received signal. The output of the 2nd IF AMP is fed from the top of the primary T5 through C22 to the detector diodes D5 and D6. When the signal at the top of T5 swings negative, D5 conducts current on to C22. As the signal swings positive, C22 discharges through D6 and charges C26. The voltage on C26 thus tends to follow the peak-to-peak voltage of the received signal and is thus the demodulated audio signal which is then fed through the AUTOMATIC NOISE LIMITING circuit, through C28 to the top of VR1 – the volume control, and from the wiper of VR1 through C39 to Q10 – the first stage of audio.

AUTOMATIC NOISE LIMITER CIRCUIT

The ANL circuit prevents impulse noise, such as ignition noise, from being amplified. The audio output voltage from the detector diodes D5 and D6 is reduced about 1/3 by voltage divider R20 and R21 and then fed to the cathode of D7 – the ANL diode. The audio output from the detector diodes is also fed through R22 to C27 where it is filtered and then fed through R23 to the anode of D7. Since the audio signal is positive, the signal at the anode of D7 is normally more positive than the cathode and the diode is forward biased providing a low impedance path for the audio to the first audio stage, Q10. When a noise pulse appears in the output of the detector, the time constant of R22 and C27 prevents the anode of D7 from responding as fast as the cathode. The cathode of D7 is thus driven more positive than the anode causing D7 to become backed biased. D7 then becomes a high impedance that blocks the noise.

SQUELCH CIRCUIT

The squelch circuit shuts the audio off when the received signal is less than the threshold level as determined by the SQUELCH CONTROL. If Q9 – the SQUELCH AMP – is off, R29, R30, and R31 form a voltage divider network that provides the proper forward bias to the base of Q10 – the first audio stage – permitting it to amplify the audio signal fed from the detector. Raising the wiper on VR2 – the SQUELCH CONTROL – tends to forward bias the base of Q9 which turns Q9 on. When Q9 is on, the forward bias is removed from the base of Q10 thus preventing amplification of the audio signal. As the received signal becomes stronger, however, the AGC voltage lowers the bias on Q9 which then permits Q10 to amplify audio. Thus raising the wiper on VR2 increases the threshold level a signal must overcome to “break squelch” – turn Q9 off and permit Q10 to amplify audio.

S METER CIRCUIT

In receive mode, meter M1 functions as an S-METER, and indicates relative strength of the received signal. When the signal swings positive at the top of the T5 secondary, current flows through D16 on to C85. As the signal swings negative, C85 discharges through D15 and charges C84. The voltage on C84 thus tends to follow the received signal strength. C84 discharges through VR5 – the S METER ADJ – to meter M1.

4.3 TRANSMITTER

In transmit mode, the output of the MASTER OSCILLATOR Q2 and the TX OSCILLATOR Q3 are mixed in the TX MIXER D12. The output of D12 is then fed through BAND PASS FILTER L4, and T8 (26.965 - 27.255 MHz) to the TX BUFFER Q15. The output of the BUFFER feeds the TX AMP Q16 which in turn feeds the TX DRIVER Q17. The TX DRIVER then feeds the TX FINAL Q18. The output of the TX FINAL is then fed through a low pass filter, L8, C78, L10, C80, L11 and C81, and a second harmonic trap CV1 and L12, to the antenna. Modulation is accomplished by driving the collector of the TX DRIVER and TX FINAL by modulated B+ derived from the lower secondary of T7 – the AUDIO OUTPUT transformer.

FREQUENCY MIXING SCHEME

Channel Selector switch S2 selects one of six crystals (X5 - X10) to set the MASTER OSCILLATOR Q2 frequency about 10MHz below the selected channel frequency. (See Table 5-3.) The output of Q2 is fed to the 1st MIXER Q5 to produce the 1st IF. S2 also selects one of four crystals (X1 - X4) for the RX OSCILLATOR Q1. The output of Q1 is fed to the 2nd MIXER Q6 to produce the 455 KHz 2nd IF. One of four crystals (X11 - X14) is also selected by S2 for the TX OSCILLATOR Q3. The outputs of the TX and MASTER OSCILLATORS are mixed in TX MIXER diode D12. The sum of the frequencies from these oscillators is selected to produce the transmitter frequency.

OVERMODULATION LIMITER

The OML regulates the gain of the audio amplifier so as to accommodate a wide range of voice levels without overmodulating the carrier. The audio signal is fed from the secondary of the audio output TRANSFORMER T2 to D18 where it is rectified; it is then filtered by C116, R40, and C43, and fed to the emitter of Q11 – the MIC AMP – through the OML adjustment VR4. As the sound level into the MIC increases, the voltage at the emitter of Q11 will rise and thus lower the amplification of the sound input.

OSCILLATORS

Crystal oscillators Q1, Q2 and Q3 are common collector, colpitts circuits. Outputs are taken from the emitters. The collectors of Q1, Q2 and Q3 are at AC ground.

RF OUTPUT METER

In transmit mode, meter M1 functions as a transmitter power output indicator. A small sample of the transmitter's RF output signal is fed by C82 to network R64, D14, and C11 where it is rectified and filtered and then fed through VR6 – the RFO ADJ – to meter M1.

FIG. 4-1 SBE-30CB TRANSCEIVER BLOCK DIAGRAM

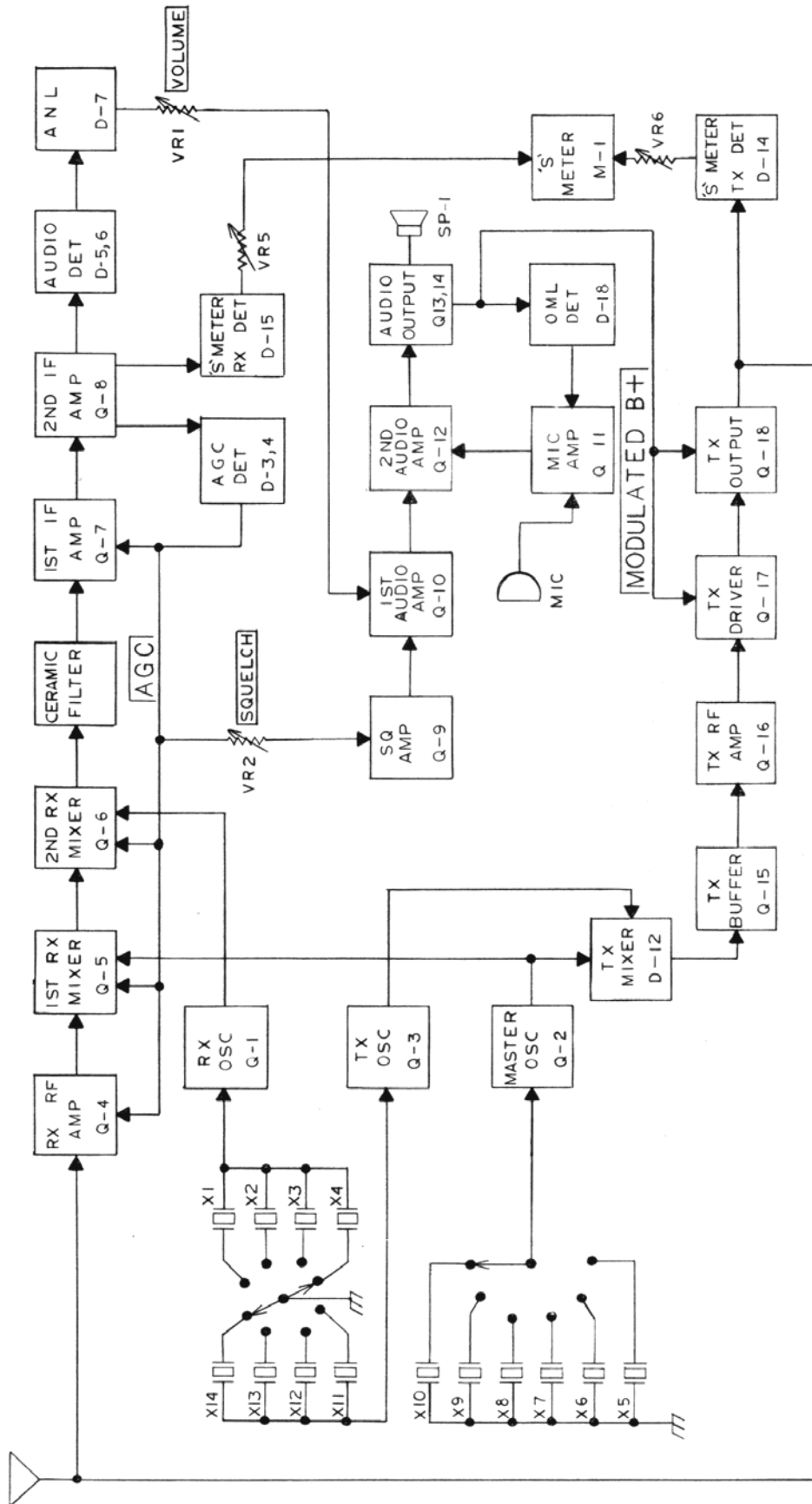

SECTION 5

SERVICING

5.1 INTRODUCTION

Read this section carefully before attempting any repair of the SBE-30CB. Refer to the circuit description, block and schematic diagrams. The transistor case diagrams are shown on the schematic diagram. Refer to these diagrams before checking transistors. Component layout and location prints are provided to aid troubleshooting and alignment. Use only recommended replacement parts. Refer to the parts list in the back of this book. **Never replace blown fuses with higher rated ones or fast acting with slow blow.** To check operation of the unit, refer to Table 5-1, PERFORMANCE VERIFICATION PROCEDURE. Figures 5-4, -5, TRANSMITTER TEST CONNECTION and RECEIVER TEST CONNECTION respectively, show the proper manner to connect the unit to test instruments for performance verification or alignment. Table 5-2 lists RECOMMENDED TEST INSTRUMENTS. Tables 5-10, -6 show the proper TRANSMITTER ALIGNMENT PROCEDURE and RECEIVER ALIGNMENT PROCEDURE respectively. Figure 5-8, ALIGNMENT LAYOUT is placed next to the alignment procedures to show alignment adjustments at a glance.

5.2 TEST SIGNALS

OSCILLOSCOPE WAVEFORMS are shown which were taken from various points in the SBE-30CB during normal operation into a dummy load. CHECK POINT numbers next to the waveform pictures correspond to numbers in boxes on both the schematic diagram and component layout drawing. Figure 5-11 shows RF amplification through a properly aligned transmitter. Figure 5-12 shows 50%, 100% and overmodulation respectively. Notice that the waveform at the ANODE of D12 – the TX MIXER – contains several frequency components. Also notice that the waveform at the collector of Q18 – the TX FINAL – is unsymmetrical (Figure 5-11e). This is proper since the TX FINAL operates class C for greater efficiency. Figure 5-11f shows how the output should look at the dummy load.

VOLTAGE MEASUREMENTS are shown on the schematic diagram for normal operation. All voltages were measured with an AC VTVM having $10M\Omega$ input impedance. Voltage measurements on high impedance RF points should be taken through a choke. While any choke about $100\mu H$ is suitable, SBE part number 8000-00011-0018 ($150\mu H$) may be ordered from the factory. Mini-test clips are very useful for making voltage measurements in hard to reach places.

RECEIVER INJECTION VOLTAGES are given in Table 5-9 together with CHECK POINT numbers which correspond to numbers in boxes on both the schematic diagram and component layout drawing. This table specifies the voltage level, carrier frequency and particular points in the receiver string at which a 30% - 1 KHz modulated signal injected through a .01 MFD capacitor should produce 2 VAC of audio across the speaker or 8Ω load plugged into the speaker jack, EXT SP. While the value of this capacitor is not critical, capacitive coupling of the signal generator to the circuit is necessary to prevent grounding out the transistor biases.

Before setting up to measure RECEIVER INJECTION VOLTAGES, small hand-held "all-purpose signal generators" can be used to provide a quick check of the receiver string. Basically, these devices generate pulses rich in harmonics from AF to RF to test whether a stage is working.

AGC VOLTAGES versus RF INPUT LEVEL are shown in Table 5-7. This table should be consulted before any adjustments are made on the squelch circuit since squelch is a function of AGC.

5.3 TROUBLESHOOTING

Troubleshooting the SBE-30CB transceiver is not essentially different than troubleshooting any other electronic device. Be a detective; suspect everything and everyone. Carefully inspect the unit for evidence of overheated components, cold solder joints, or tampering. Understand thoroughly the circuit description and block diagram. Try to start big and isolate the problem. Devise tests that will divide the transceiver in two and isolate the trouble to a particular half. Continue to divide into two parts until the trouble is located. For example, it is determined that a problem exists in a particular transceiver. The unit is divided into:

TRANSMITTER – RECEIVER.

Suppose that the receiver functions properly but there is no carrier when the transmitter is keyed. Since the receiver audio works, it can be assumed that all of the audio amplifier is good except the MIC AMP Q10 – the condition of which is yet unknown. The MASTER OSCILLATOR can be assumed working since it is used by both the transmitter and receiver. After checking the TX/RX relay RL-1 and transmitter B+, the transmitter is then divided into:

BEFORE TX AMP – TX AMP and AFTER.

Figure 5-11, TRANSMIT ALIGNMENT WAVEFORMS, shows typical waveforms taken at various points in an SBE-30CB transmitter during normal operation. Place an oscilloscope probe on the collector of Q15. If a signal is present and doesn't differ significantly from the waveform picture then the problem exists after Q15. Keep dividing until the trouble is found.

This technique is sometimes called, "partitioning," "boxing-in-the-trouble," "divide and conquer," or "binary search"; it is mandatory for complex electronic systems, but can save time and energy on almost any electronic device.

A blown fuse should only be replaced by one of the proper rating and type. If the fuse blows again, replace it, but place an Ω meter at the power terminals in place of the supply. Make certain that the + side of the Ω meter is connected to the red power wire of the SBE-30CB. Some VOM's place the - side of the Ω meter out the red test jack. Observe that D17 protects the unit from a reversed supply.

The second harmonic trap (L12 and CV1) is adjusted at the Factory; field adjustment should not be attempted without proper equipment. Failure of particular channels to work or be on frequency probably indicates a defective crystal. Refer to Table 5-3 SYNTHESIZER MIXING SCHEME. Notice that the same Transmit and Receive crystals are used every fourth channel while each Master crystal is used on four adjacent channels. Check channel selector switch, S2, by swapping crystals.

FIG. 5-1 PERFORMANCE VERIFICATION PROCEDURE

TRANSMITTER

INITIAL SET-UP

Connect the SBE-30CB to 120 volts AC. Connect a wattmeter, dummy load and oscilloscope to the antenna jack.

STEP 1

Key the transmitter and observe that the wattmeter indicates an output of at least 3 watts and that the RFO meter indicates about the same.

STEP 2

Whistle into microphone with transmitter keyed. Check for 90-100% modulation.

STEP 3

Connect counter to dummy load and check transmit frequencies on channels 1, 2, 3, 4, 8, 12, 16, and 20. (See Table 5-3.)

RECEIVER

INITIAL SET-UP

Connect SBE-30CB to 120 volts AC. Connect RF signal generator to the antenna jack and set to 27.085 MHz 30% - 1 KHz modulation. Set the unit to channel 11. Turn the volume control full clockwise and the squelch control full counterclockwise. Connect 8Ω load to external speaker jack, EXT SP and connect AC VTVM to 8Ω load. (See Figure 5-5.)

STEP 1

Adjust signal generator for $0.7\mu V$ output. Verify that at least 2 VAC appear across the 8Ω load.

STEP 2

Increase signal generator output to $200\mu V$. Rotate squelch knob full clockwise. Receiver should squelch.

STEP 3

Adjust signal generator for $100\mu V$. S-METER should read about 9.

FIG. 5-2 RECOMMENDED TEST INSTRUMENTS

<u>TEST INSTRUMENT</u>	<u>REQUIRED SPECIFICATIONS</u>	<u>USE</u>	<u>RECOMMENDED INSTRUMENT TYPE</u>
R.F. Signal Generator	Output frequency: 26.965 to 27.255 MHz. Output level calibrated from .1 microvolts to 500,000 microvolts. Internal modulation capability of 30% minimum at 1 KHz. (Calibrated)	Receiver service and alignment.	Hewlett-Packard Model 606A or B. Wavetek Model 3000.
Oscilloscope	Vertical bandwidth of 25 MHz or greater at 3db point. Triggered sweep capability.	Transmitter and receiver test and alignment.	Tektronics Model T932. Tektronics Model 465. Hewlett-Packard Model 180. Phillips Model PM3260E.
Frequency Counter	Frequency range DC to 30 MHz. Sensitivity: 10mv R.M.S. at 30 MHz. Overall timebase accuracy $\pm .002\%$, 6 digit resolution.	Transmitter frequency check and synthesizer troubleshooting.	Heath-Schlumberger Model SM128A
Wattmeter	5 watts full scale into 50 ohm load $\pm 5\%$ accuracy.	Measure power output and S.W.R.	Bird Model 43 with type 5A element. (May be terminated with antenna load)
AC VTVM	-40 to +20db range.	Measure audio output.	Heath Model IM-21.
Audio Oscillator	400 Hz to 4000 Hz output: Adjustable level, 0-1 volt output impedance 600 ohm.	Audio and modulator tests.	Hewlett-Packard Model 204C. Heath Model SG18A.
DC Power Supply	13.8 volt DC $\pm 10\%$ at 2 amperes.	Voltage for servicing.	Heath Model SP2720 (SBE Model SBE-1AC may be used if available.)

TABLE 5-3 SBE-30CB SYNTHESIZER MIXING SCHEME

CH.	CH. FREQ.	MASTER OSC. XTAL FREQ.	TX OSC. XTAL FREQ.	RX OSC. XTAL FREQ.
1	26.965	X5 = 16.965	X11 = 10,000	X1 = 9.545
2	26.975		X12 = 10,010	X2 = 9.555
3	26.985		X13 = 10,020	X3 = 9.565
4	27.005		X14 = 10,040	X4 = 9.585
5	27.015	X6 = 17.015	X11	X1
6	27.025		X12	X2
7	27.035		X13	X3
8	27.055		X14	X4
9	27.065	X7 = 17.065	X11	X1
10	27.075		X12	X2
11	27.085		X13	X3
12	27.105		X14	X4
13	27.115	X8 = 17.115	X11	X1
14	27.125		X12	X2
15	27.135		X13	X3
16	27.155		X14	X4
17	27.165	X9 = 17.165	X11	X1
18	27.175		X12	X2
19	27.185		X13	X3
20	27.205		X14	X4
21	27.215	X10 = 17.215	X11	X1
22	27.225		X12	X2
23	27.255		X14	X4

RECEIVE:

$$(\text{CH FREQ}) - (\text{M.O. FREQ}) - (\text{RX OSC FREQ}) = 455 \text{ KHz}$$

TRANSMIT:

$$(\text{M.O. FREQ}) + (\text{TX OSC FREQ}) = (\text{CH FREQ})$$

FIG. 5-4 TRANSMITTER TEST CONNECTION

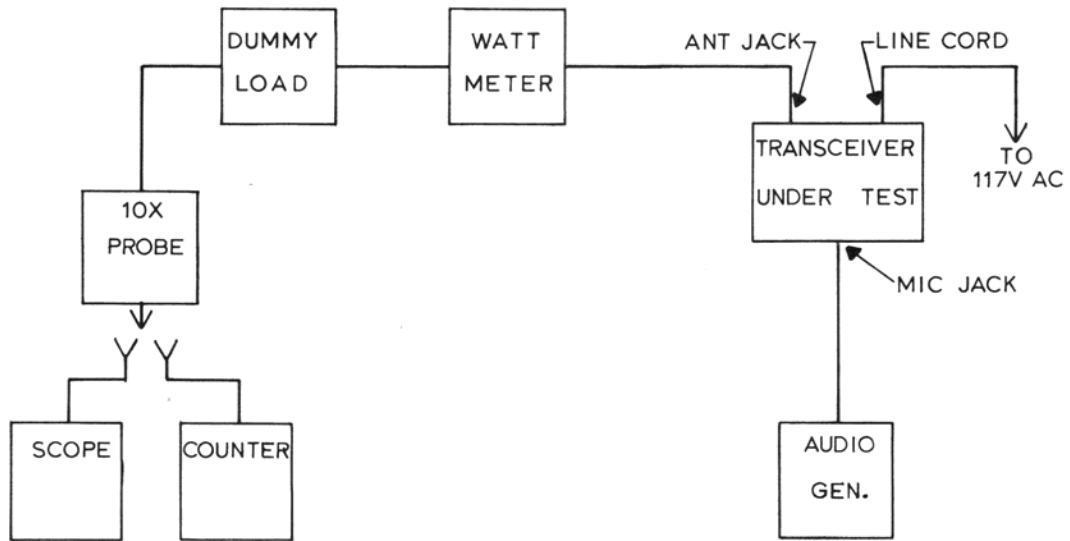

FIG. 5-5 RECEIVER TEST CONNECTION

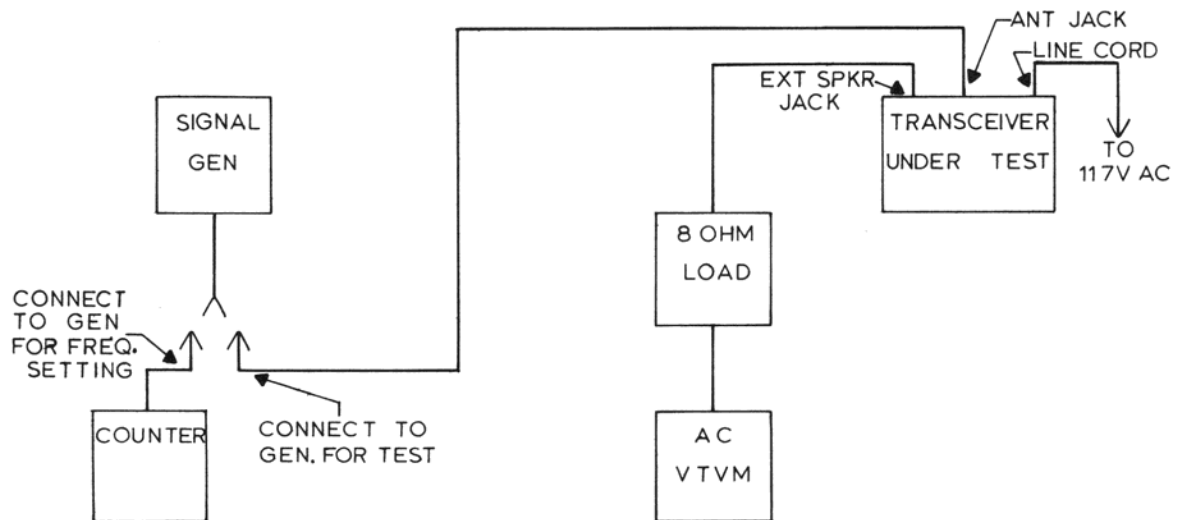

FIG. 5-6 RECEIVER ALIGNMENT PROCEDURE

INITIAL SET-UP	
<p>Connect an AC VTVM across the speaker or 8Ω load plugged into J3 EXT SP. Connect the RF signal generator to the antenna jack, set to 27.085 MHz 30% - 1 KHz modulation. Set the Channel Select SW to channel 11. Turn the squelch control full counterclockwise and the volume control full clockwise.</p>	
<u>STEP 1</u>	
<p>Adjust the RF output level of the signal generator to a level sufficient to produce about 2 VAC on the AC VTVM. Adjust T1, T2, L1, L2, T3, T4 and T5 for maximum indications on the AC VTVM. If at any time during the alignment procedure the audio level increases to more than 4 VAC, reduce the generator output level. Repeat adjustment until $0.7 \mu\text{V}$ RF signal produces about 2 VAC on the AC VTVM.</p>	
<u>STEP 2</u>	
<p>Turn squelch control full clockwise. Increase the RF signal to $300\mu\text{V}$. Squelch should break. If squelch fails to break, adjust VR3 to break squelch.</p>	
<u>STEP 3</u>	
<p>Turn squelch control full counterclockwise. Set RF signal generator to 10 MHz. Adjust 10 MHz trap L9 for minimum indication on the AC VTVM.</p>	
<u>STEP 4</u>	
<p>Set RF signal generator to $100 \mu\text{V}$ at 27.085 MHz. Adjust VR5 to make the S METER indicate 9.</p>	

TABLE 5-7 AGC VOLTAGES versus RF INPUT LEVEL

INPUT LEVEL (1)	AGC VOLTAGES (2)
$1\mu\text{V}$	+1.35
$10\mu\text{V}$	+1.21
$100\mu\text{V}$	+0.97
$1000\mu\text{V}$	+0.82
$10,000\mu\text{V}$	+0.74
0.1V	+0.70

(1) Channel Frequency at Antenna Jack.

(2) Measured with $10M\Omega$ input at junction R19 and C25.

FIG. 5-8 ALIGNMENT LAYOUT

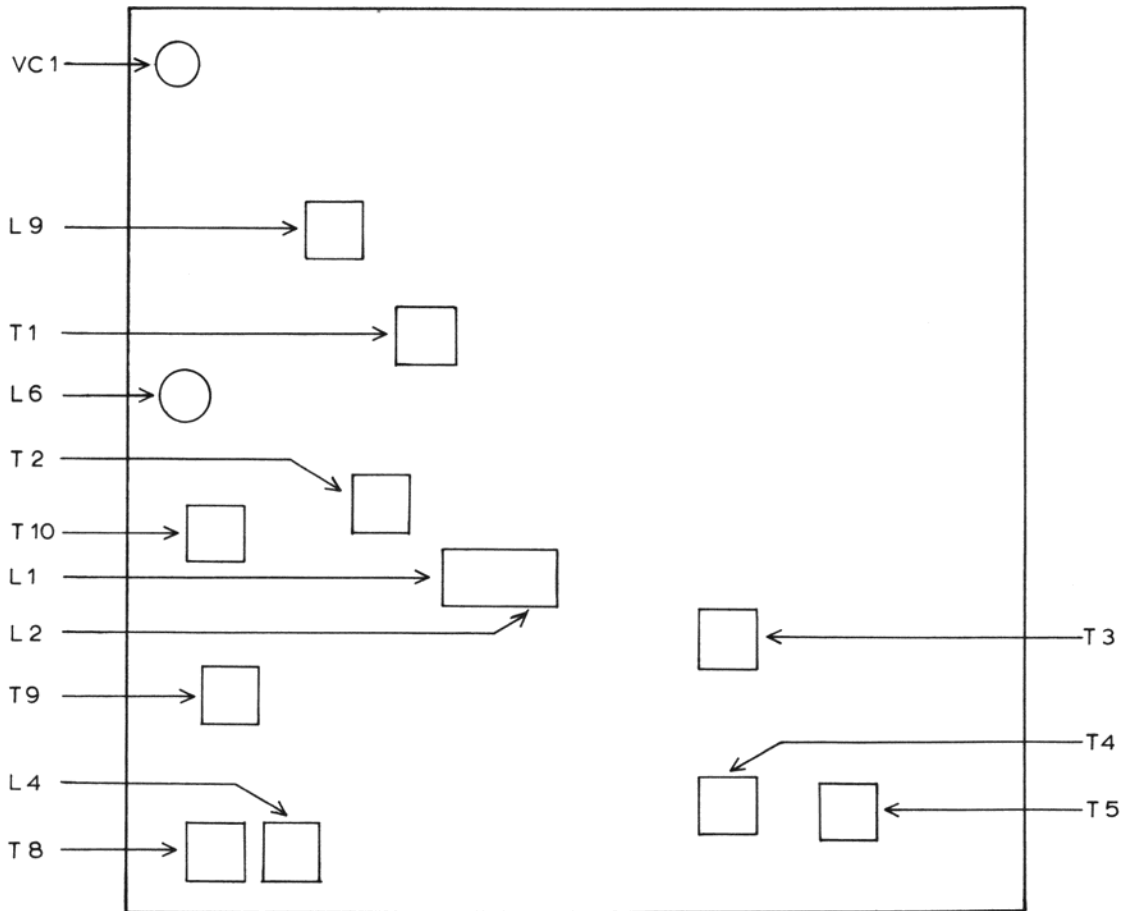

TABLE 5-9 RECEIVER INJECTION VOLTAGES

All injection voltages are at 30% - 1 KHz modulation at the specified frequency fed through a .01 MFD capacitor, and should produce at least 2 VAC audio output measured across the speaker or across an 8Ω load connected at EXT SP J2. Typical audio output voltages are given.

INJECTION POINT	INJECTION LEVEL	FREQUENCY	AUDIO OUTPUT
ANT JACK J1	1μV	Channel Freq.	4.6V
Base of Q4 - CP1 *	1μV	Channel Freq.	4.0V
Base of Q5 - CP2	10μV	Channel Freq.	2.8V
Base of Q6 - CP3	100μV	10.02 MHz	3.4V
Base of Q7 - CP4	300μV	455 MHz	5.0V
Base of Q8 - CP5	3000μV	455 MHz	2.5V

* CP numbers correspond to numbers in boxes on schematic diagram and component location drawing.

FIG. 5-10 TRANSMITTER ALIGNMENT PROCEDURE

INITIAL SET-UP
Connect the transceiver to 120 volts AC. Connect an audio oscillator to the MIC input, a wattmeter and dummy load to the antenna jack, an oscilloscope to the dummy load, and set the channel selector to channel 11. (See Figure 5-5.)
<u>STEP 1</u> With no modulation, key the transmitter and adjust L4, L6, T8, T9, and T10 for maximum wattmeter indication.
<u>STEP 2</u> Alternately, switch channel selector to channel 1 and 23. Adjust L4 and T8 for least change in wattmeter indication.
<u>STEP 3</u> Adjust L8 and L10 for maximum wattmeter indication not to exceed 4 watts.
<u>STEP 4</u> Set the audio oscillator to 1 KHz. Adjust output level for about 80% modulation. While observing scope, adjust L8 and L10 for best modulation symmetry.
<u>STEP 5</u> Adjust the audio oscillator's level for 50% modulation. Read level on AC VTVM and increase level until the AC VTVM reads 8 times as great (about 18db). Adjust VR4 for 100% modulation.
<u>STEP 6</u> Remove audio oscillator. Adjust VR6 until RFO METER reads the same as wattmeter.

FIG. 5-11 TRANSMITTER ALIGNMENT WAVEFORMS

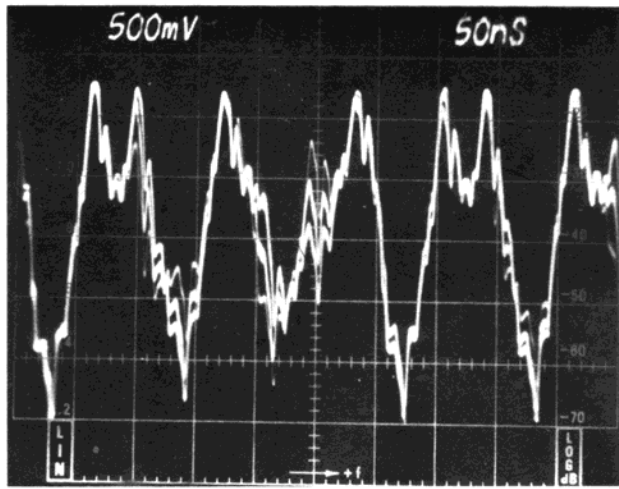

(a) D12 ANODE-TX MIXER 6

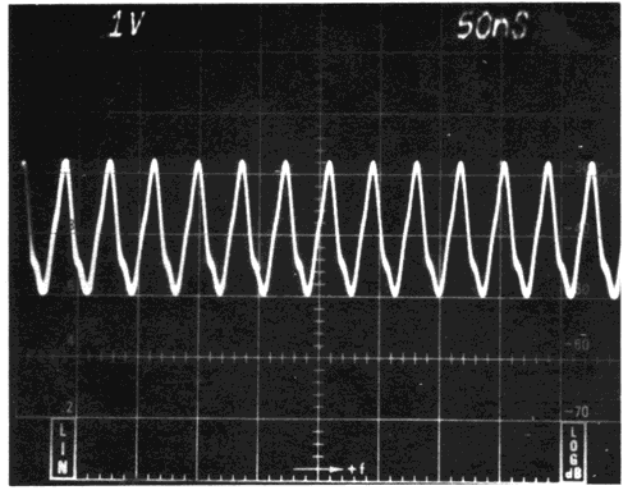

(b) Q15 COLLECTOR-TX BUFFER 7

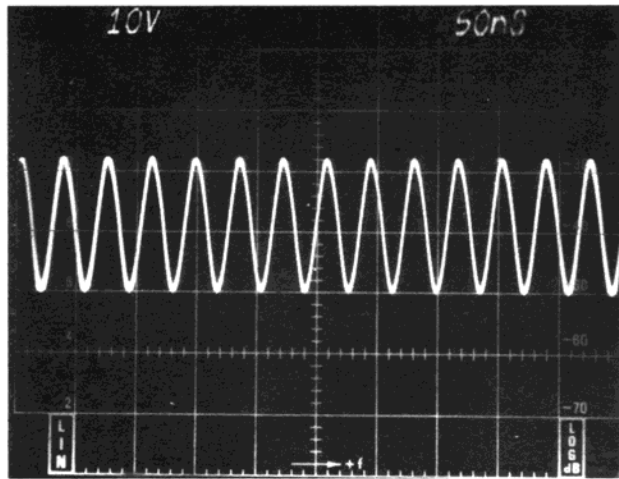

(c) Q 16 COLLECTOR-TX AMP 8

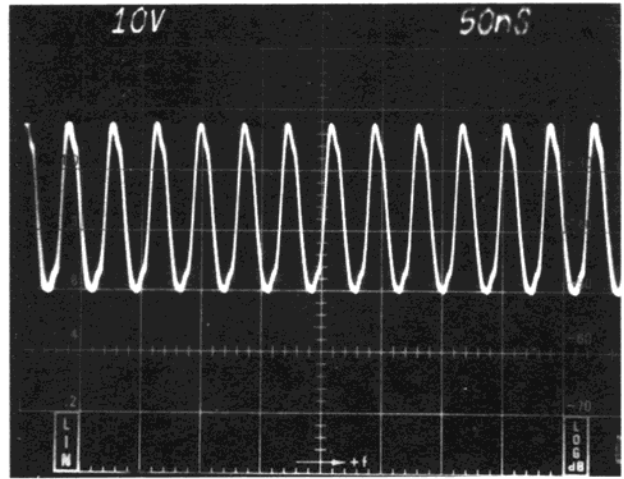

(d) Q17 COLLECTOR-TX DRIVER 9

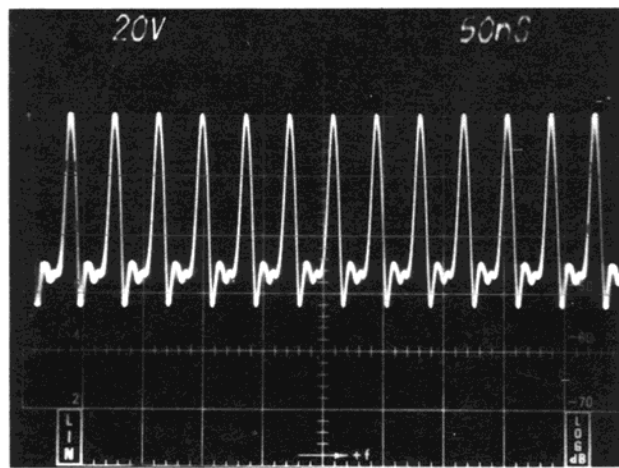

(e) Q18 COLLECTOR-TX FINAL 10

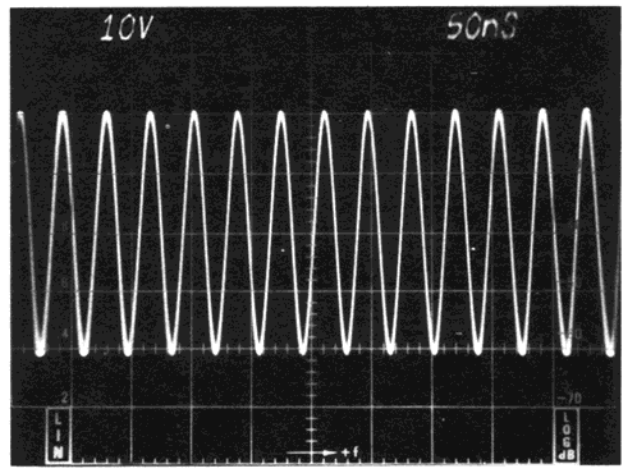

(f) ANTENNA JACK

FIG. 5-12 MODULATION WAVEFORMS

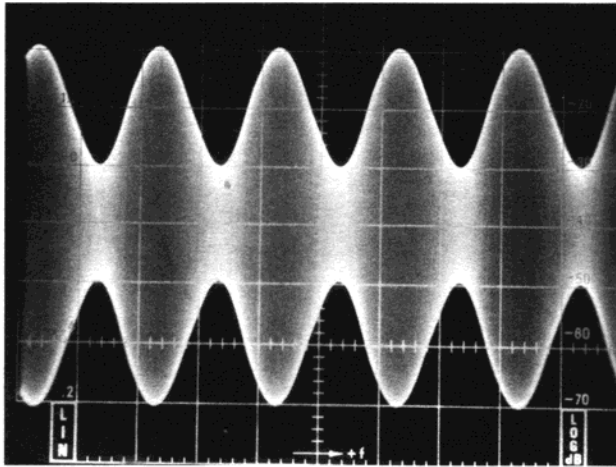

50% MODULATION

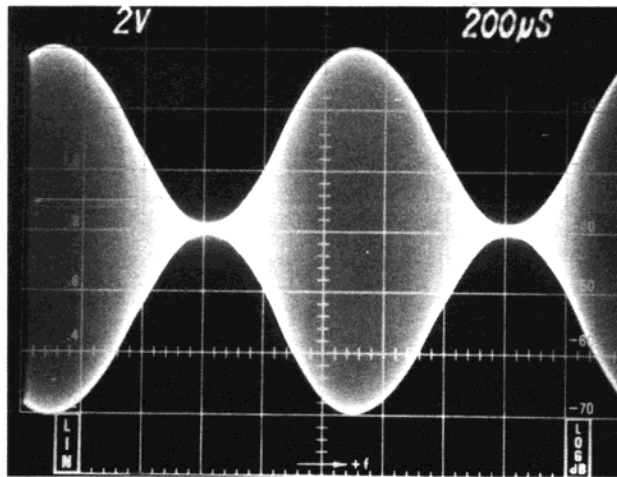

100% MODULATION

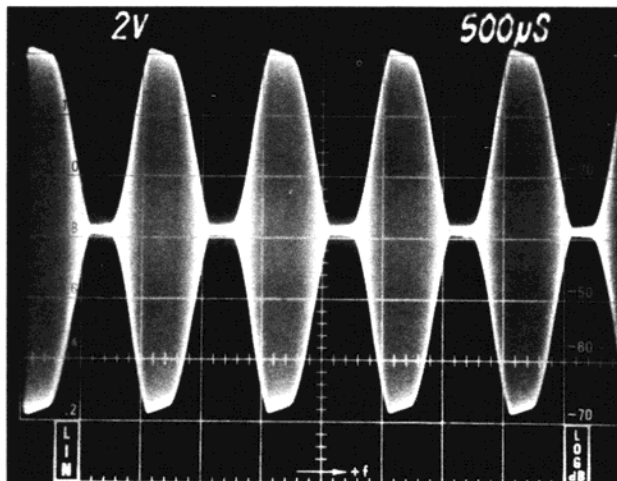

OVERMODULATION

FIG. 5-13 COMPONENT LAYOUT

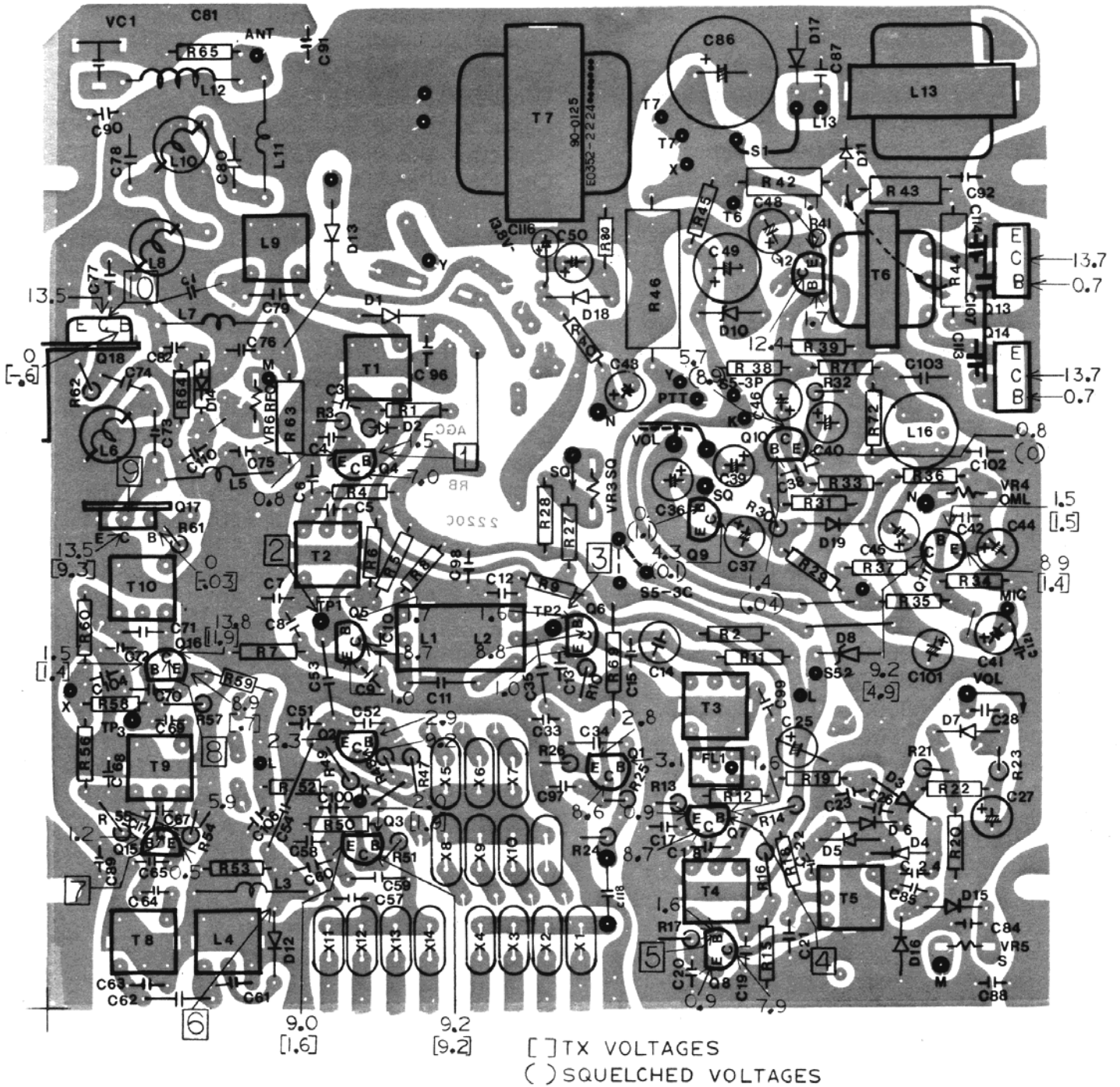

SBE-30CB TRINIDAD II PARTS LIST

<u>SYMBOL #</u>	<u>PART #</u>	<u>DESCRIPTION</u>
C1	8000-00004-016	Capacitor, Fixed, 20pfd, ±10%, 50V, Mica
C3	8000-00006-079	Capacitor, Fixed, 0.01mfd, 50V, Cer.
C4	8000-00006-079	Capacitor, Fixed, 0.01mfd, 50V, Cer.
C5	8000-00004-024	Capacitor, Fixed, 30pfd, ±10%, 50V, Mica
C6	8000-00006-079	Capacitor, Fixed, 0.01mfd, 50V, Cer.
C7	8000-00006-079	Capacitor, Fixed, 0.01mfd, 50V, Cer.
C8	8000-00006-079	Capacitor, Fixed, 0.01mfd, 50V, Cer.
C9	8000-00006-079	Capacitor, Fixed, 0.01mfd, 50V, Cer.
C10	8000-00006-079	Capacitor, Fixed, 0.01mfd, 50V, Cer.
C11	8000-00004-028	Capacitor, Fixed, 1pfd, ±10%, 50V, Mica
C12	8000-00004-003	Capacitor, Fixed, 0.04mfd, ±10%, 50V, Mylar
C13	8000-00004-003	Capacitor, Fixed, 0.04mfd, ±10%, 50V, Mylar
C14	8000-00004-014	Capacitor, Fixed, 1500pfd, ±10%, 50V, Styrol
C15	8000-00006-079	Capacitor, Fixed, 0.01mfd, 50V, Cer.
C17	8000-00004-003	Capacitor, Fixed, 0.04mfd, ±10%, 50V, Mylar
C18	8000-00004-003	Capacitor, Fixed, 0.04mfd, ±10%, 50V, Mylar
C19	8000-00004-003	Capacitor, Fixed, 0.04mfd, ±10%, 50V, Mylar
C20	8000-00004-003	Capacitor, Fixed, 0.04mfd, ±10%, 50V, Mylar
C21	8000-00004-003	Capacitor, Fixed, 0.04mfd, ±10%, 50V, Mylar
C22	8000-00004-020	Capacitor, Fixed, 100pfd, ±10%, 50V, Mica
C23	8000-00004-003	Capacitor, Fixed, 0.04mfd, ±10%, 50V, Mylar
C24	8000-00006-077	Capacitor, Fixed, 0.001mfd, 50V, Cer.
C25	8000-00006-065	Capacitor, Fixed, 10mfd, 16V, Elect.
C26	8000-00006-077	Capacitor, Fixed, 0.001mfd, 50V, Cer.
C27	8000-00011-002	Capacitor, Fixed, 2.2mfd, 16V, Elect.
C28	8000-00006-079	Capacitor, Fixed, 0.01mfd, 50V, Cer.
C32	8000-00006-273	Capacitor, Fixed, 35pfd, ±10%, 50V, Mica
C33	8000-00004-041	Capacitor, Fixed, 150pfd, ±10%, 50V, Mica
C34	8000-00004-017	Capacitor, Fixed, 500pfd, ±10%, 50V, Mica
C35	8000-00006-272	Capacitor, Fixed, 5.6pfd, ±10%, 50V, Mica
C36	8000-00006-064	Capacitor, Fixed, 4.7mfd, 16V, Elect.
C37	8000-00006-063	Capacitor, Fixed, 1mfd, 16V, Elect.
C38	8000-00006-079	Capacitor, Fixed, 0.01mfd, 50V, Cer.
C39	8000-00006-063	Capacitor, Fixed, 1mfd, 16V, Elect.
C40	8000-00006-065	Capacitor, Fixed, 10mfd, 16V, Elect.
C41	8000-00006-292	Capacitor, Fixed, 0.47mfd, 16V, Elect.
C42	8000-00006-079	Capacitor, Fixed, 0.01mfd, 50V, Cer.
C43	8000-00006-064	Capacitor, Fixed, 4.7mfd, 16V, Elect.
C44	8000-00006-065	Capacitor, Fixed, 10mfd, 16V, Elect.
C45	8000-00006-063	Capacitor, Fixed, 1mfd, 16V, Elect.
C46	8000-00006-063	Capacitor, Fixed, 1mfd, 16V, Elect.
C48	8000-00006-067	Capacitor, Fixed, 100mfd, 16V, Elect.
C49	8000-00006-164	Capacitor, Fixed, 220mfd, 16V, Elect.
C50	8000-00006-064	Capacitor, Fixed, 4.7mfd, 16V, Elect.
C51	8000-00012-004	Capacitor, Fixed, 65pfd, ±10%, 50V, Mica
C52	8000-00004-027	Capacitor, Fixed, 220pfd, ±10%, 50V, Mica
C53	8000-00004-002	Capacitor, Fixed, 15pfd, ±10%, 50V, Mica
C54	8000-00006-050	Capacitor, Fixed, 5pfd, ±10%, 50V, Mica
C58	8000-00004-020	Capacitor, Fixed, 100pfd, ±10%, 50V, Mica

<u>SYMBOL #</u>	<u>PART #</u>	<u>DESCRIPTION</u>
C59	8000-00004-017	Capacitor, Fixed, 500pfd, $\pm 10\%$, 50V, Mica
C60	8000-00004-016	Capacitor, Fixed, 20pfd, $\pm 10\%$, 50V, Mica
C61	8000-00004-007	Capacitor, Fixed, 10pfd, $\pm 10\%$, 50V, Mica
C62	8000-00006-277	Capacitor, Fixed, 1pfd, $\pm 10\%$, 50V, Mica
C63	8000-00004-006	Capacitor, Fixed, 24pfd, $\pm 10\%$, 50V, Mica
C64	8000-00006-077	Capacitor, Fixed, 0.001mfd, 50V, Cer.
C65	8000-00006-079	Capacitor, Fixed, 0.01mfd, 50V, Cer.
C67	8000-00004-006	Capacitor, Fixed, 24pfd, $\pm 10\%$, 50V, Mica
C68	8000-00006-079	Capacitor, Fixed, 0.01mfd, 50V, Cer.
C69	8000-00006-077	Capacitor, Fixed, 0.001mfd, 50V, Cer.
C70	8000-00006-079	Capacitor, Fixed, 0.01mfd, 50V, Cer.
C71	8000-00004-041	Capacitor, Fixed, 150pfd, $\pm 10\%$, 50V, Mica
C72	8000-00006-079	Capacitor, Fixed, 0.01mfd, 50V, Cer.
C73	8000-00004-006	Capacitor, Fixed, 24pfd, $\pm 10\%$, 50V, Mica
C74	8000-00004-020	Capacitor, Fixed, 100pfd, $\pm 10\%$, 50V, Mica
C75	8000-00006-079	Capacitor, Fixed, 0.01mfd, 50V, Cer.
C76	8000-00006-079	Capacitor, Fixed, 0.01mfd, 50V, Cer.
C77	8000-00006-079	Capacitor, Fixed, 0.01mfd, 50V, Cer.
C78	8000-00006-275	Capacitor, Fixed, 270pfd, $\pm 10\%$, 50V, Mica
C79	8000-00004-023	Capacitor, Fixed, 300pfd, $\pm 10\%$, 50V, Mica
C80	8000-00012-006	Capacitor, Fixed, 200pfd, $\pm 10\%$, 50V, Mica
C81	8000-00006-274	Capacitor, Fixed, 75pfd, $\pm 10\%$, 50V, Mica
C82	8000-00004-028	Capacitor, Fixed, 1pfd, $\pm 10\%$, 50V, Mica
C84	8000-00004-003	Capacitor, Fixed, 0.04mfd, $\pm 10\%$, 50V, Mylar
C85	8000-00004-023	Capacitor, Fixed, 300pfd, $\pm 10\%$, 50V, Mica
C86	8000-00006-068	Capacitor, Fixed, 1000mfd, 16V, Elect.
C88	8000-00004-012	Capacitor, Fixed, 0.047mfd, 50V, Cer.
C89	8000-00004-012	Capacitor, Fixed, 0.047mfd, 50V, Cer.
C90	8000-00004-012	Capacitor, Fixed, 0.047mfd, 50V, Cer.
C92	8000-00004-012	Capacitor, Fixed, 0.047mfd, 50V, Cer.
C93	8000-00004-012	Capacitor, Fixed, 0.047mfd, 50V, Cer.
C96	8000-00006-079	Capacitor, Fixed, 0.01mfd, 50V, Cer.
C97	8000-00006-079	Capacitor, Fixed, 0.01mfd, 50V, Cer.
C100	8000-00006-079	Capacitor, Fixed, 0.01mfd, 50V, Cer.
C101	8000-00006-164	Capacitor, Fixed, 220mfd, 16V, Elect.
C102	8000-00006-276	Capacitor, Fixed, 0.047mfd, $\pm 10\%$, 50V, Mylar
C103	8000-00004-018	Capacitor, Fixed, 0.1mfd, $\pm 10\%$, 50V, Mylar
C105	8000-00006-079	Capacitor, Fixed, 0.01mfd, 50V, Cer.
C106	8000-00006-079	Capacitor, Fixed, 0.01mfd, 50V, Cer.
C107	8000-00006-079	Capacitor, Fixed, 0.01mfd, 50V, Cer.
C110	8000-00006-079	Capacitor, Fixed, 0.01mfd, 50V, Cer.
C113	8000-00006-079	Capacitor, Fixed, 0.01mfd, 50V, Cer.
C114	8000-00006-079	Capacitor, Fixed, 0.01mfd, 50V, Cer.
C115	8000-00004-017	Capacitor, Fixed, 500pfd, $\pm 10\%$, 50V, Mica
C116	8000-00006-065	Capacitor, Fixed, 10mfd, 16V, Elect.
C117	8000-00006-079	Capacitor, Fixed, 0.01mfd, 50V, Cer.
C118	8000-00004-017	Capacitor, Fixed, 500pfd, $\pm 10\%$, 50V, Mica
C119	8000-00006-079	Capacitor, Fixed, 0.01mfd, 50V, Cer.
C120	8000-00006-079	Capacitor, Fixed, 0.01mfd, 50V, Cer.
C121	8000-00006-079	Capacitor, Fixed, 0.01mfd, 50V, Cer.
C201	8000-00011-113	Capacitor, Fixed, 0.0022mfd, 150V, Cer.
C202	8000-00011-113	Capacitor, Fixed, 0.0022mfd, 150V, Cer.

<u>SYMBOL #</u>	<u>PART #</u>	<u>DESCRIPTION</u>
C203	8000-00011-102	Capacitor, Fixed, 3300mfd, 35V, Elect.
C204	8000-00006-067	Capacitor, Fixed, 100mfd, 16V, Elect.
C205	8000-00006-079	Capacitor, Fixed, 0.01mfd, 50V, Cer.
CV1	8000-00004-204	Capacitor, Var., 10pfd, Max., Cer., Trimmer
D1	8000-00038-008	Diode, WG713
D2	8000-00006-007	Diode, 1N60
D3	8000-00006-007	Diode, 1N60
D4	8000-00006-007	Diode, 1N60
D5	8000-00006-007	Diode, 1N60
D6	8000-00006-007	Diode, 1N60
D7	8000-00004-064	Diode, 1S84
D8	8000-00011-043	Diode, BZ090
D10	8000-00011-043	Diode, BZ090
D11	8000-00011-045	Diode, 1S1211
D12	8000-00006-281	Diode, 1S2473
D13	8000-00030-010	Diode, 1N4002
D14	8000-00006-007	Diode, 1N60
D15	8000-00006-007	Diode, 1N60
D16	8000-00006-007	Diode, 1N60
D18	8000-00006-007	Diode, 1N60
D19	8000-00006-007	Diode, 1N60
D201	8000-00030-010	Diode, 1N4002
D202	8000-00030-010	Diode, 1N4002
D203	8000-00011-103	Diode, BZ071
D204	8000-00011-103	Diode, BZ071
D205	8000-00011-104	Diode, V03C
FL1	8000-00006-291	Ceramic Filter, LF-A8
L1	8000-00012-032	Transformer, IF, 42K-10
L2	8000-00012-032	Transformer, IF, 42K-10
L3	8000-00004-053	Choke Coil, 22 μ h
L4	8000-00012-023	HF Coil, 507SY1
L5	8000-00030-011	Choke Coil, 2.5 μ h
L6	8000-00006-285	HF Coil, S-18 (Violet)
L7	8000-00004-055	Choke Coil, 0.65 μ h
L8	8000-00030-017	HF Coil, S-18 (White)
L9	8000-00012-029	HF Coil, Z343QD
L10	8000-00030-017	HF Coil, S-18 (White)
L11	8000-00011-016	Choke Coil, 0.22 μ h
L12	8000-00004-059	Choke Coil, 0.85 μ h
L13	8000-00011-022	Choke Coil, K-10
L16	8000-00006-284	Choke Coil, K-58
Q1	8000-00006-003	Transistor, 2SC710
Q2	8000-00006-003	Transistor, 2SC710
Q3	8000-00006-003	Transistor, 2SC710
Q4	8000-00006-003	Transistor, 2SC710
Q5	8000-00006-003	Transistor, 2SC710
Q6	8000-00006-003	Transistor, 2SC710

<u>SYMBOL #</u>	<u>PART #</u>	<u>DESCRIPTION</u>
Q7	8000-00006-003	Transistor, 2SC710
Q8	8000-00006-Q03	Transistor, 2SC710
Q9	8000-00006-003	Transistor, 2SC710
Q10	8000-00006-003	Transistor, 2SC710
Q11	8000-00032-027	Transistor, 2SD187
Q12	8000-00006-003	Transistor, 2SC710
Q13	8000-00004-087	Transistor, 2SC1014
Q14	8000-00004-087	Transistor, 2SC1014
Q15	8000-00006-003	Transistor, 2SC710
Q16	8000-00006-003	Transistor, 2SC710
Q17	8000-00006-278	Transistor, 2SC495T
Q18	8000-00006-279	Transistor, 2SC1678
Q201	8000-00006-190	Transistor, E0961
Q202	8000-00006-280	Transistor, 2SC1364
R44	8000-00006-271	Resistor, Fixed, 0.5 Ω , 1W, Oxide Film
R46	8000-00006-270	Resistor, Fixed, 200 Ω , 2W, \pm 10%, Carbon
R101	8000-00032-005	Resistor, Fixed, 150 Ω , 1W, Oxide Film
RL1	8000-00030-022	Relay, HTC-12
T1	8000-00006-287	HF Coil, C360DD
T2	8000-00006-288	HF Coil, P362AT
T3	8000-00012-033	IF Transformer, A086AD
T4	8000-00012-034	IF Transformer, EIA 227B
T5	8000-00012-035	IF Transformer, EIA 146D
T6	8000-00004-119	Input Transformer, A01A
T7	8000-00006-290	Output Transformer, E52
T8	8000-00012-024	HF Coil, 507S3Y
T9	8000-00006-286	HF Coil, C305BD
T10	8000-00006-289	HF Coil, C042DD
VR1	8000-00006-282	Resistor, Var., 10K Ω D type w/switch
VR2	8000-00006-283	Resistor, Var., 10K Ω B type
VR3	8000-00004-097	Resistor, Var., 10K Ω 2T, Trimmer
VR4	8000-00004-097	Resistor, Var., 10K Ω 2T, Trimmer
VR5	8000-00004-093	Resistor, Var., 50K Ω 2T, Trimmer
VR6	8000-00004-094	Resistor, Var., 100K Ω 2T, Trimmer
X1	8000-00012-043	Crystal, 9.545 MHz, HC25/U
X2	8000-00012-044	Crystal, 9.555 MHz, HC25/U
X3	8000-00012-045	Crystal, 9.565 MHz, HC25/U
X4	8000-00012-046	Crystal, 9.585 MHz, HC25/U
X5	8000-00012-047	Crystal, 16.965 MHz, HC25/U
X6	8000-00012-048	Crystal, 17.015 MHz, HC25/U
X7	8000-00012-049	Crystal, 17.065 MHz, HC25/U
X8	8000-00012-050	Crystal, 17.115 MHz, HC25/U
X9	8000-00012-051	Crystal, 17.165 MHz, HC25/U
X10	8000-00012-052	Crystal, 17.215 MHz, HC25/U
X11	8000-00012-053	Crystal, 10.000 MHz, HC25/U
X12	8000-00012-054	Crystal, 10.010 MHz, HC25/U
X13	8000-00012-055	Crystal, 10.020 MHz, HC25/U
X14	8000-00012-056	Crystal, 10.040 MHz, HC25/U

<u>SYMBOL #</u>	<u>PART #</u>	<u>DESCRIPTION</u>
	8000-00006-115	Knob, Channel
	8000-00006-204	Knob, Volume & Squelch
	8000-00006-293	Channel Disk
	8000-00006-294	Heat Sink, Final
	8000-00006-295	Heat Sink, Driver
	8000-00006-296	Front Bezel
	8000-00004-260	Lamp Grommet
	8000-00006-090	Antenna Connector
	8000-00004-153	Microphone
	8000-00011-124	Fuse Holder
	8000-00006-091	Fuse, 2A
	8000-00011-056	Pilot Lamp 14V, 75ma
	8000-00006-297	Meter A-56
	8000-00006-298	Speaker
	8000-00004-070	Microphone Jack
	8000-00004-164	Microphone Plug
	8000-00004-157	Microphone Hook
	8000-00006-299	F.C.C. Label
	8000-00011-135	Power Supply, PCB
	8000-00006-255	Rotary Switch 24T
	8000-00006-157	AC Power Cord
	8000-00011-128	DC Terminal
	8000-00006-154	Switch, Lever
	8000-00006-088	Jack for Ext. Speaker
	8000-00006-301	Terminal Strip
	8000-00006-302	Fuse w/pigtails
	8000-00006-305	Cabinet
	8000-00006-306	Mount, Channel Switch
	8000-00006-307	Mount, Speaker
	8000-00006-308	Mount, Lever Switch
	8000-00006-309	Mount, Meter
	8000-00006-310	Speaker Grill
	8000-00006-116	Channel Window
	8000-00006-311	Front Overlay
	8000-00006-312	Plate, Brand SBE
	8000-00006-313	Front rubber foot
	8000-00011-137	Rear rubber foot
	8000-00006-314	Meter Insulator
	8000-00006-203	Cord Stopper
	8000-00006-315	Styrofoam Box
	8000-00006-316	Display Box
	8000-00006-317	PCB Relay
	8000-00006-318	Plastic Screw to Mount 2SC1014

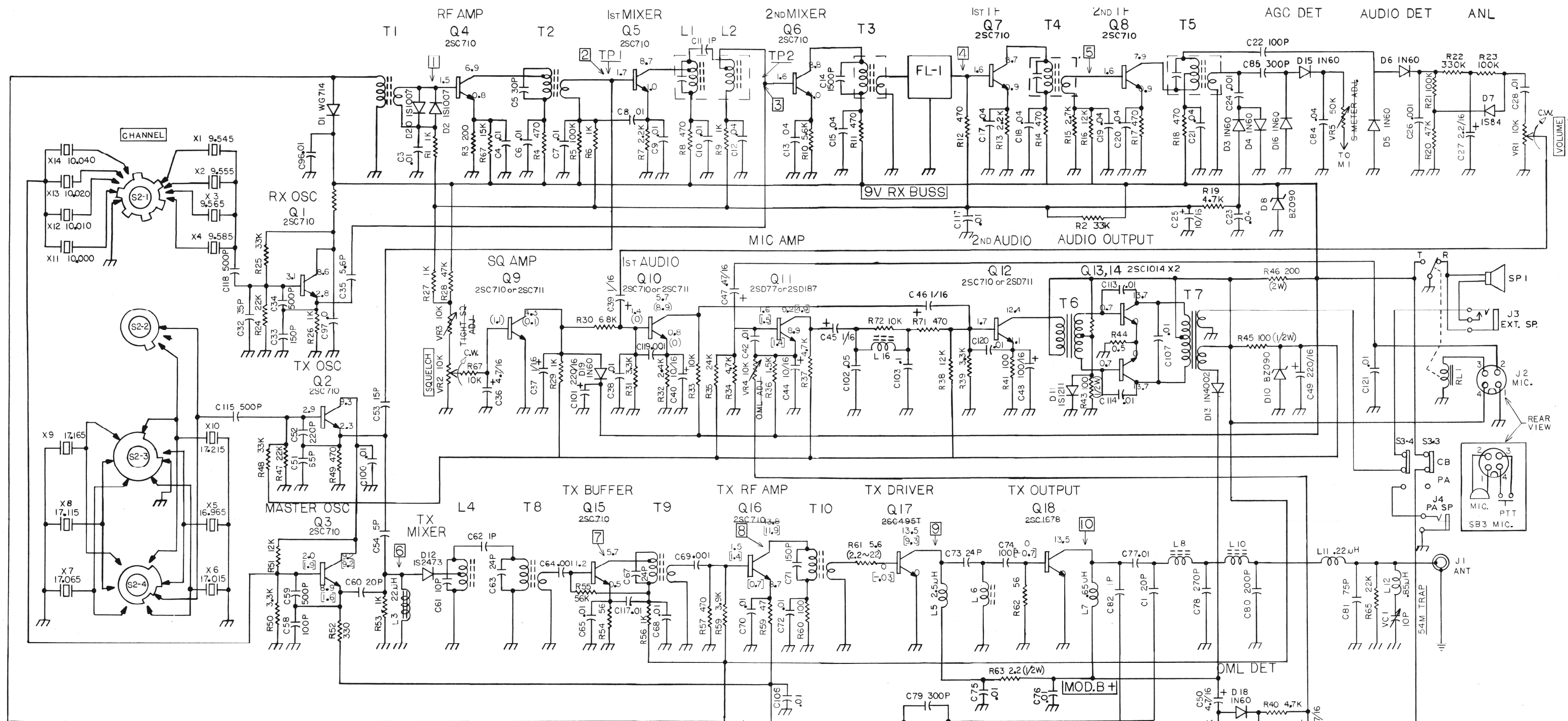

TRANSISTOR CASE DIAGRAMS (BOTTOM VIEW)

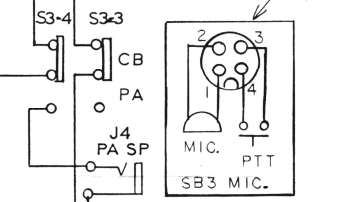
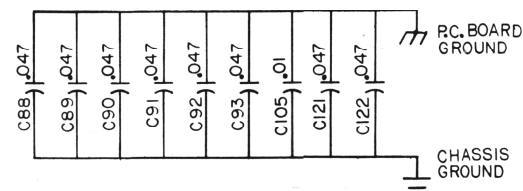
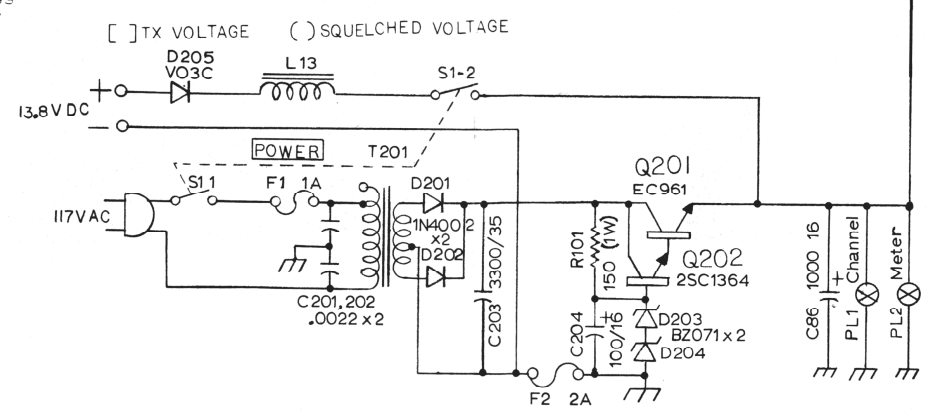
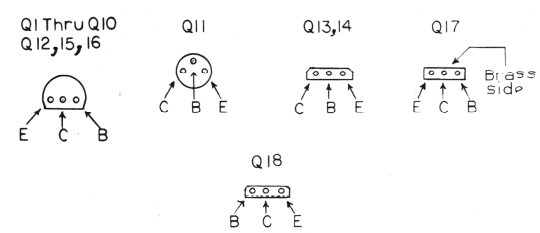

VOLUME

J1 ANT

J2 MIC

J3 EXT. SP

J4 PA SP

J5 MIC

SB3 MIC

REAR VIEW

SP1

EXT. SP

MIC

PTT

SB3 MIC

REAR VIEW

SP1

EXT. SP

MIC

PTT

SB3 MIC

REAR VIEW

SP1

EXT. SP

MIC

PTT

SB3 MIC

REAR VIEW

SP1

EXT. SP

MIC

PTT

SB3 MIC

REAR VIEW

SP1

EXT. SP

MIC

PTT

SB3 MIC

REAR VIEW

SP1

EXT. SP

MIC

PTT

SB3 MIC

REAR VIEW

SP1

EXT. SP

MIC

PTT

SB3 MIC

REAR VIEW

SP1

EXT. SP

MIC

PTT

SB3 MIC

REAR VIEW

SP1

EXT. SP

MIC

PTT

SB3 MIC

REAR VIEW

SP1

EXT. SP

MIC

PTT

SB3 MIC

REAR VIEW

SP1

EXT. SP

MIC

PTT

SB3 MIC

REAR VIEW

SP1

EXT. SP

MIC

PTT

SB3 MIC

REAR VIEW

SP1

EXT. SP

MIC

PTT

SB3 MIC

REAR VIEW

SP1

EXT. SP

MIC

PTT

SB3 MIC

REAR VIEW

SP1

EXT. SP

