

# SERVICE MANUAL

SBE 27 CB/A  
Sidebender IV

SBE 39 CB  
Sidebender V

SBE 40 CB  
Console V

SBE, INC.  
220 AIRPORT BLVD.  
WATSONVILLE, CA 95076

## RECEIVER

### INITIAL SET-UP

Connect the unit to an appropriate 13.8VDC or 117VAC power source. Connect RF signal generator to the antenna jack and set to 27.205 MHz. Set the unit to channel 20. Turn the volume control full clockwise, the squelch control full counterclockwise, RF gain control full clockwise, scan switch to the OFF position and center clarifier. Connect 8 ohm load to external speaker jack, EXT SP, and connect AC voltmeter to 8 ohm load. (See Figure 5-?)

---

#### Step 1

Set the mode selector to AM. Adjust signal generator for 1.0uV output with 30% - 1 KHz modulation. Verify that at least 4VAC appear across the 8 ohm load.

---

#### Step 2

Increase signal generator output to 200uV. Rotate squelch control knob full clockwise. Receiver should squelch.

---

#### Step 3

Adjust signal generator for 100uV. S meter should read approximately S-9.

---

#### Step 4

Remove connection from external speaker jack if used. Adjust signal generator for 0.5uV output with no modulation. Set the mode selector to LSB. Rotate clarifier back and forth. Tone should be heard at one end of the clarifier.

---

#### Step 5

Repeat step 4 in USB.

---

#### Step 6

Rotate the squelch control slow clockwise. Check squelch meter to insure that meter is indicating proper squelch action.

---

#### Step 7

Adjust squelch control to mute background noise. Place scan switch to the on position and insure that the unit scans through all 40 channels.

---

### NOISE BLANKER ALIGNMENT

1. Connect oscilloscope to junction anode D306 and cathode D308.
2. Inject 24.5 MHz RF signal at antenna connector. Peak L301, T302, and T303.
3. Inject RF signal 100 KHz above channel frequency (27.065 = 27.165). Null T301.
4. With signal generator still set at 100 KHz above channel frequency, and at a level of 1mv, connect a VOM to collector Q302 and adjust T304 for a null.

## AM MODE

RECEIVE INJECTION VOLTAGES

<u>INJECTION POINT</u>	<u>INJECTION LEVEL</u>	<u>FREQUENCY</u>	<u>AUDIO VOLTAGE</u>
Antenna Jack	1uV	27.205 MHz	>2V @ $\frac{1}{2}$ Volume
Q101 gate 1	10uV	27.205 MHz	>2V @ $\frac{1}{2}$ Volume
Q102 gate	30uV	7.8 MHz	72V @ $\frac{1}{2}$ Volume
Q201 base	30uV	7.8 MHz	72V @ $\frac{1}{2}$ Volume
Q202 base	100uV	7.8 MHz	72V @ $\frac{1}{2}$ Volume
Q203	1000uV	7.8 MHz	72V @ $\frac{1}{2}$ Volume

## TRANSMITTER ALIGNMENT PROCEDURE

### INITIAL SET-UP

Connect unit with appropriate 13.8VDC or 117VAC power source. Turn on and select AM mode. Connect a suitable RF load to the antenna output terminals.

---

#### Step 1

Connect a DC voltmeter to TP1. Select channel 1 AM mode and adjust L901 for an observed voltage of 2.0 volts  $\pm$  0.1 volts.

---

#### Step 2

Connect a digital frequency counter to the 19 MHz output (C914). Select channel 20 AM receive mode and set the clarifier control to the 12:00 o'clock position. Adjust L905 for an observed frequency of 19.405 MHz.

---

#### Step 3

Maintaining the set up as in step 2, switch to USB receive mode and adjust L904 for an observed frequency of 19.4075 MHz.

---

#### Step 4

Maintaining the set up as in step 2, switch to AM mode and key the transmitter. Adjust VR801 for an observed frequency of 19.4025 MHz.

---

#### Step 5

Switch the digital frequency counter to the transmitter output. Connect an audio signal generator to the microphone input and inject a 1000 Hertz tone. Select channel 20, LSB mode and key the transmitter. Adjust CV701 for an observed frequency of 27.204 MHz.

---

#### Step 6

Maintaining the set up as in step 5, switch to USB and key the transmitter. Adjust L703 for an observed frequency of 27.206 MHz.

---

#### Step 7

After completing the steps outlined above, select channel 20, USB mode and connect either a watt meter or a peak reading RF voltmeter such as a Hewlett Packard HP-410B to the antenna output terminals.

---

### Step 8

Disable the ALC system by rotating VR302.

---

### Step 9

Connect an audio signal generator to the microphone input and inject a 1000 Hertz signal. Key the transmitter and adjust the audio level to produce approximately 15 watts PEP.

---

### Step 10

Tune the following in sequence for maximum RF output, reducing the audio drive whenever the output power goes over 15 watts PEP.

A.	L801	(VCO output)
B.	L902	(VCO buffer amp)
C.	T201	(IF AMP)
D.	T503, 502	(27 MHz filter)
E.	T501	(Interstage 27 KHz xfmr)
F.	L507	(Interstage "T" network coil)
G.	L505	(Interstage "T" network coil)
H.	L502	(Output Z-matching coil)

---

### Step 11

Repeat adjustments G and H once more to optimize the impedance match.

---

### Step 12

Connect a two tone audio signal generator to the microphone input, setting the tones at 500 Hertz and 2400 Hertz with relative amplitudes set to produce a close-to-equal amplitude RF resultant.

---

### Step 13

Key the transmitter and increase the audio composite level to the point where no further increase in power output is noted. Adjust ALC VR302 for a reading of 11-12 watts PEP (23.5-24.5 volts).

---

### Step 14

Change to the AM mode and apply a 1 KHz tone to the mike input.

---

### Step 15

With an oscilloscope attached to the antenna terminals, key the transmitter and observe the modulation envelope. Set the audio level for a 50% modulation.

---

Step 16

Increase the audio input by 20db (10 times the voltage).

---

Step 17

Adjust OML control VR803 for less than 100% modulation (no clipping of the envelope either on the positive or negative peaks). Adjust VR2 OML module output level for a 1db drop in modulation percentage.

---

Step 18

Using a spectrum analyzer or frequency selective voltmeter, sample the RF output at the second harmonic (=54 MHz) and adjust CV101 for a null of this spurious emission.

---

Step 19

Switch back to the USB or LSB mode and key the transmitter with the audio input grounded to prevent modulation.

---

Step 20

With a sensitive voltmeter or spectrum analyzer adjust VR701 and VR724 for minimum transmitted carrier.

---

Step 21

Using a spectrum analyzer, adjust L509 for minimum 19 MHz output.

---

AGC VOLTAGE VERSUS RF INPUT LEVEL MEASURED AT Q401 SOURCE

<u>INPUT LEVEL @ ANTENNA JACK</u>	<u>AGC VOLTAGE</u>
NC	1.85
1uV	1.69
10uV	1.36
100uV	1.18
1000uV	1.00
10,000uV	0.85



	MODE		f vco	flo	f ref	fif	
1 26.965	AM	TX	19.1625	7.8025	9.9987	N/A	
		RX	19.1650	N/A	10.0000	7.8000	
	USB	TX	19.1675	7.7975	9.9987	N/A	
		RX	19.1675	7.7975	9.9987	7.7975	
	LSB	TX	19.1625	7.8025	9.9987	N/A	
		RX	19.1625	7.8025	9.9987	7.8025	
2 26.975	AM	TX	19.1725				
		RX	19.1750				
	USB	TX	19.1775				
		RX	19.1775				
	LSB	TX	19.1725				
		RX	19.1725				
3 26.985	AM	TX	19.1825				
		RX	19.1850				
	USB	TX	19.1875				
		RX	19.1875				
	LSB	TX	19.1825				
		RX	19.1825				
4 27.005	AM	TX	19.2025				
		RX	19.2050				
	USB	TX	19.2075				
		RX	19.2075				
	LSB	TX	19.2025				
		RX	19.2025				
5 27.015	AM	TX	19.2125				
		RX	19.2150				
	USB	TX	19.2175				
		RX	19.2175				
	LSB	TX	19.2125				
		RX	19.2125				
6 27.025	AM	TX	19.2225				
		RX	19.2250				
	USB	TX	19.2275				
		RX	19.2275				
	LSB	TX	19.2225				
		RX	19.2225				
7 27.035	AM	TX	19.2325				
		RX	19.2350				
	USB	TX	19.2375				
		RX	19.2375				
	LSB	TX	19.2325				
		RX	19.2325				
8 27.055	AM	TX	19.2525				
		RX	19.2550				
	USB	TX	19.2575				
		RX	19.2575				
	LSB	TX	19.2525				
		RX	19.2525				

same as Channel 1

same as Channel 1

same as Channel 1

same as Channel 1

same as Channel 1

same as Channel 1

same as Channel 1

	MODE		f vco	flo	f ref	fif
9 27.065	AM	TX	19.2625	<i>same as Channel 1</i>		
		RX	19.2650			
	USB	TX	19.2675			
		RX	19.2675			
	LSB	TX	19.2625			
		RX	19.2625			
10 27.075	AM	TX	19.2725	<i>same as Channel 1</i>		
		RX	19.2750			
	USB	TX	19.2775			
		RX	19.2775			
	LSB	TX	19.2725			
		RX	19.2725			
11 27.085	AM	TX	19.2825	<i>same as Channel 1</i>		
		RX	19.2850			
	USB	TX	19.2875			
		RX	19.2875			
	LSB	TX	19.2825			
		RX	19.2825			
12 27.105	AM	TX	19.3025	<i>same as Channel 1</i>		
		RX	19.3050			
	USB	TX	19.3075			
		RX	19.3075			
	LSB	TX	19.3025			
		RX	19.3025			
13 27.115	AM	TX	19.3125	<i>same as Channel 1</i>		
		RX	19.3150			
	USB	TX	19.3175			
		RX	19.3175			
	LSB	TX	19.3125			
		RX	19.3125			
14 27.125	AM	TX	19.3225	<i>same as Channel 1</i>		
		RX	19.3250			
	USB	TX	19.3275			
		RX	19.3275			
	LSB	TX	19.3225			
		RX	19.3225			
15 27.135	AM	TX	19.3325	<i>same as Channel 1</i>		
		RX	19.3350			
	USB	TX	19.3375			
		RX	19.3375			
	LSB	TX	19.3325			
		RX	19.3325			
16 27.155	AM	TX	19.3525	<i>same as Channel 1</i>		
		RX	19.3550			
	USB	TX	19.3575			
		RX	19.3575			
	LSB	TX	19.3525			
		RX	19.3525			

	MODE		f vco	flo	f ref	fif
17 27.165	AM	TX	19.3625	<i>same as Channel 1</i>		
		RX	19.3650			
	USB	TX	19.3675			
		RX	19.3675			
	LSB	TX	19.3625			
		RX	19.3625			
18 27.175	AM	TX	19.3725	<i>same as Channel 1</i>		
		RX	19.3750			
	USB	TX	19.3775			
		RX	19.3775			
	LSB	TX	19.3725			
		RX	19.3725			
19 27.185	AM	TX	19.3825	<i>same as Channel 1</i>		
		RX	19.3850			
	USB	TX	19.3875			
		RX	19.3875			
	LSB	TX	19.3825			
		RX	19.3825			
20 27.205	AM	TX	19.4025	<i>same as Channel 1</i>		
		RX	19.4050			
	USB	TX	19.4075			
		RX	19.4075			
	LSB	TX	19.4025			
		RX	19.4025			
21 27.215	AM	TX	19.4125	<i>same as Channel 1</i>		
		RX	19.4150			
	USB	TX	19.4175			
		RX	19.4175			
	LSB	TX	19.4125			
		RX	19.4125			
22 27.225	AM	TX	19.4225	<i>same as Channel 1</i>		
		RX	19.4250			
	USB	TX	19.4275			
		RX	19.4275			
	LSB	TX	19.4225			
		RX	19.4225			
23 27.255	AM	TX	19.4525	<i>same as Channel 1</i>		
		RX	19.4550			
	USB	TX	19.4575			
		RX	19.4575			
	LSB	TX	19.4525			
		RX	19.4525			
24 27.255	AM	TX	19.4325	<i>same as Channel 1</i>		
		RX	19.4350			
	USB	TX	19.4375			
		RX	19.4375			
	LSB	TX	19.4325			
		RX	19.4325			

	MODE		f vco	flo	f ref	fif
25 27.245	AM	TX	19.4425	<i>same as Channel 1</i>		
		RX	19.4450			
	USB	TX	19.4475			
		RX	19.4475			
	LSB	TX	19.4425			
		RX	19.4425			
26 27.265	AM	TX	19.4625	<i>same as Channel 1</i>		
		RX	19.4650			
	USB	TX	19.4675			
		RX	19.4675			
	LSB	TX	19.4625			
		RX	19.4625			
27 27.275	AM	TX	19.4725	<i>same as Channel 1</i>		
		RX	19.4750			
	USB	TX	19.4775			
		RX	19.4775			
	LSB	TX	19.4725			
		RX	19.4725			
28 27.285	AM	TX	19.4825	<i>same as Channel 1</i>		
		RX	19.4850			
	USB	TX	19.4875			
		RX	19.4875			
	LSB	TX	19.4825			
		RX	19.4825			
29 27.295	AM	TX	19.4925	<i>same as Channel 1</i>		
		RX	19.4950			
	USB	TX	19.4975			
		RX	19.4975			
	LSB	TX	19.4925			
		RX	19.4925			
30 27.305	AM	TX	19.5025	<i>same as Channel 1</i>		
		RX	19.5050			
	USB	TX	19.5075			
		RX	19.5075			
	LSB	TX	19.5025			
		RX	19.5025			
31 27.315	AM	TX	19.5125	<i>same as Channel 1</i>		
		RX	19.5150			
	USB	TX	19.5175			
		RX	19.5175			
	LSB	TX	19.5125			
		RX	19.5125			
32 27.325	AM	TX	19.5225	<i>same as Channel 1</i>		
		RX	19.5250			
	USB	TX	19.5275			
		RX	19.5275			
	LSB	TX	19.5225			
		RX	19.5225			

	MODE		f vco	flo	f ref	fif
33 27.335	AM	TX	19.5325	<i>same as Channel 1</i>		
		RX	19.5350			
	USB	TX	19.5375			
		RX	19.5375			
	LSB	TX	19.5325			
		RX	19.5325			
34 27.345	AM	TX	19.5425	<i>same as Channel 1</i>		
		RX	19.5450			
	USB	TX	19.5475			
		RX	19.5475			
	LSB	TX	19.5425			
		RX	19.5425			
35 27.355	AM	TX	19.5525	<i>same as Channel 1</i>		
		RX	19.5550			
	USB	TX	19.5575			
		RX	19.5575			
	LSB	TX	19.5525			
		RX	19.5525			
36 27.365	AM	TX	19.5625	<i>same as Channel 1</i>		
		RX	19.5650			
	USB	TX	19.5675			
		RX	19.5675			
	LSB	TX	19.5625			
		RX	19.5625			
37 27.375	AM	TX	19.5725	<i>same as Channel 1</i>		
		RX	19.5750			
	USB	TX	19.5775			
		RX	19.5775			
	LSB	TX	19.5725			
		RX	19.5725			
38 27.385	AM	TX	19.5825	<i>same as Channel 1</i>		
		RX	19.5850			
	USB	TX	19.5875			
		RX	19.5875			
	LSB	TX	19.5825			
		RX	19.5825			
39 27.395	AM	TX	19.5925	<i>same as Channel 1</i>		
		RX	19.5950			
	USB	TX	19.5975			
		RX	19.5975			
	LSB	TX	19.5925			
		RX	19.5925			
40 27.405	AM	TX	19.6025	<i>same as Channel 1</i>		
		RX	19.6050			
	USB	TX	19.6075			
		RX	19.6075			
	LSB	TX	19.6025			
		RX	19.6025			

MC14568  
IC901

MC14526  
IC902

Pin #	4	5	6	7	2	14	11	5	
	P <sub>4</sub> P <sub>3</sub> P <sub>2</sub> P <sub>1</sub>				P <sub>4</sub> P <sub>3</sub> P <sub>2</sub> P <sub>1</sub>				N=
CH									
1	1	0	1	0	0	1	1	1	167
2	1	0	1	0	0	1	0	1	165
3	1	0	1	0	0	0	1	1	163
4	1	0	0	1	1	1	1	1	159
5	1	0	0	1	1	1	0	1	157
6	1	0	0	1	1	0	1	1	155
7	1	0	0	1	1	0	0	1	153
8	1	0	0	1	0	1	0	1	149
9	1	0	0	1	0	0	1	1	147
10	1	0	0	1	0	0	0	1	145
11	1	0	0	0	1	1	1	1	143
12	1	0	0	0	1	0	1	1	139
13	1	0	0	0	1	0	0	1	137
14	1	0	0	0	0	1	1	1	135
15	1	0	0	0	0	1	0	1	133
16	1	0	0	0	0	0	0	1	129
17	0	1	1	1	1	1	1	1	127
18	0	1	1	1	1	1	0	1	125
19	0	1	1	1	1	0	1	1	123
20	0	1	1	1	0	1	1	1	119
21	0	1	1	1	0	1	0	1	117
22	0	1	1	1	0	0	1	1	115
23	0	1	1	0	1	1	0	1	109
24	0	1	1	0	1	1	1	1	111
25	0	1	1	1	0	0	0	1	113
26	0	1	1	0	1	0	1	1	107
27	0	1	1	0	1	0	0	1	105
28	0	1	1	0	0	1	1	1	103
29	0	1	1	0	0	1	0	1	101
30	0	1	1	0	0	0	1	1	99
31	0	1	1	0	0	0	0	1	97
32	0	1	0	1	1	1	1	1	95
33	0	1	0	1	1	1	0	1	93
34	0	1	0	1	1	0	1	1	91
35	0	1	0	1	1	0	0	1	89
36	0	1	0	1	0	1	1	1	87
37	0	1	0	1	0	1	0	1	85
38	0	1	0	1	0	0	1	1	83
39	0	1	0	1	0	0	0	1	81
40	0	1	0	0	1	1	1	1	79

AM/LSB  
5V

USB  
0V

MIXING SCHEME

	fvco	flo	fref	fif
	VCO	Local Osc.	Reference Osc.	Receive IF Freq.
transmit	19.1625 MHz	7.8025 MHz	9.9987 MHz	N/A
AM receive	19.1650 MHz	N/A	10.000 MHz	7.800 MHz
transmit	19.1625 MHz	7.8025 MHz	9.9987 MHz	N/A
LSB receive	19.1625 MHz	7.8025 MHz	9.9987 MHz	7.8025 MHz
transmit	19.1675 MHz	7.7975 MHz	9.9987 MHz	N/A
USB receive	19.1675 MHz	7.7975 MHz	9.9987 MHz	7.7975 MHz

$$frx - fvco = fif$$

$$fvco + flo = flx$$

IC804

Pin #	17	18	19	20	21	22	23
	B <sub>2</sub>	B <sub>1</sub>	B <sub>0</sub>	A <sub>3</sub>	A <sub>2</sub>	A <sub>1</sub>	A <sub>0</sub>

CH

1	0	0	0	0	0	0	1
2	0	0	0	0	0	1	0
3	0	0	0	0	0	1	1
4	0	0	0	0	1	0	0
5	0	0	0	0	1	0	1
6	0	0	0	0	1	1	0
7	0	0	0	0	1	1	1
8	0	0	0	1	0	0	0
9	0	0	0	1	0	0	1
10	0	0	1	0	0	0	0
11	0	0	1	0	0	0	1
12	0	0	1	0	0	1	0
13	0	0	1	0	0	1	1
14	0	0	1	0	1	0	0
15	0	0	1	0	1	0	1
16	0	0	1	0	1	1	0
17	0	0	1	0	1	1	1
18	0	0	1	1	0	0	0
19	0	0	1	1	0	0	1
20	0	1	0	0	0	0	0
21	0	1	0	0	0	0	1
22	0	1	0	0	0	1	0
23	0	1	0	0	0	1	1
24	0	1	0	0	1	0	0
25	0	1	0	0	1	0	1
26	0	1	0	0	1	1	0
27	0	1	0	0	1	1	1
28	0	1	0	1	0	0	0
29	0	1	0	1	0	0	1
30	0	1	1	0	0	0	0
31	0	1	1	0	0	0	1
32	0	1	1	0	0	1	0
33	0	1	1	0	0	1	1
34	0	1	1	0	1	0	0
35	0	1	1	0	1	0	1
36	0	1	1	0	1	1	0
37	0	1	1	0	1	1	1
38	0	1	1	1	0	0	0
39	0	1	1	1	0	0	1
40	1	0	0	0	0	0	0

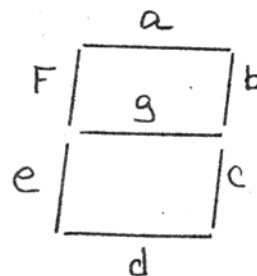

IC804-5

$\frac{15}{f}$   $\frac{14}{g}$   $\frac{13}{a}$   $\frac{12}{b}$   $\frac{11}{c}$   $\frac{10}{d}$   $\frac{9}{e}$

3 = 1 0 0 0 0 0 1



# BLOCK DIAGRAM DIGITAL PLL SYNTHESIZER

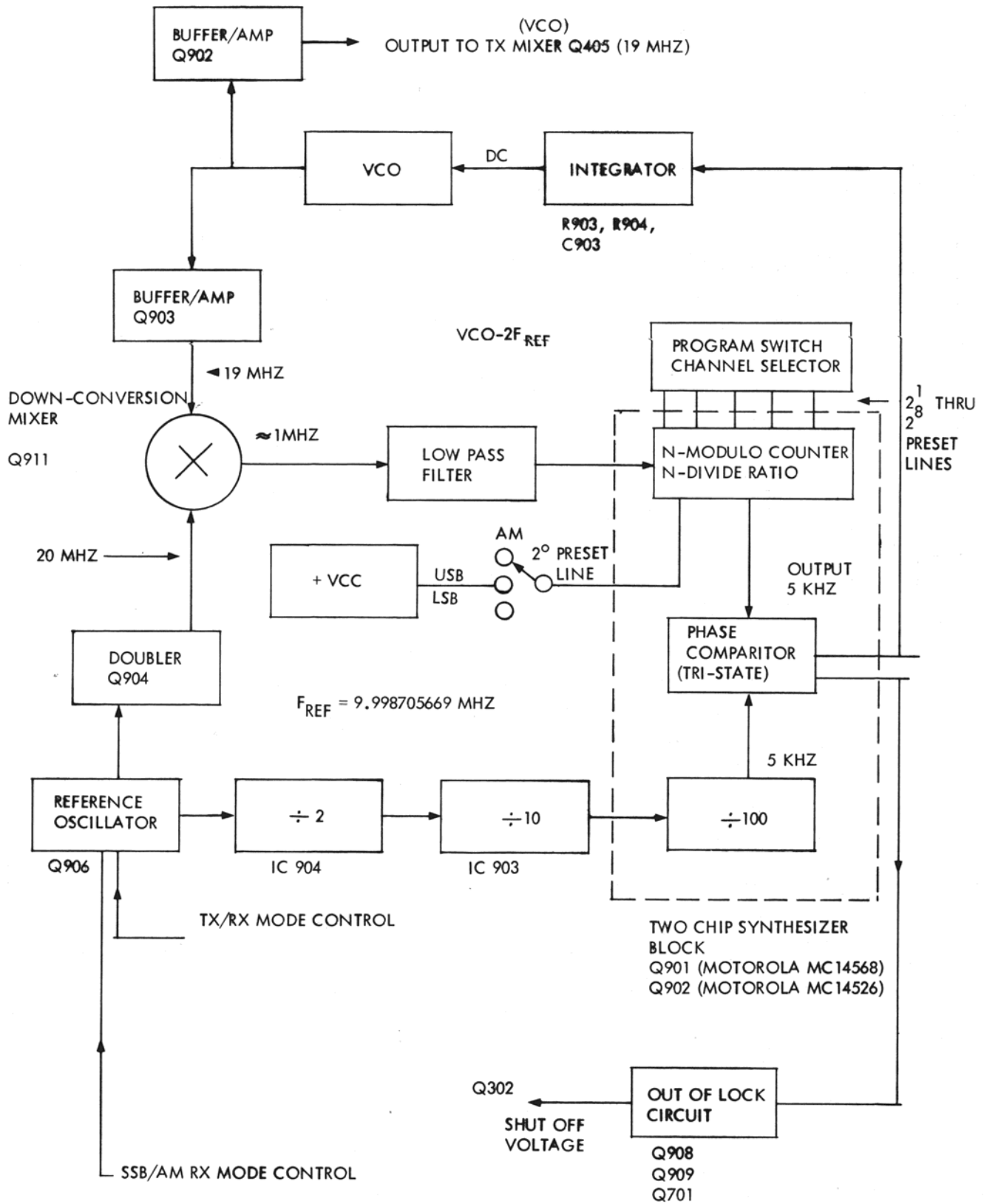

# BLOCK DIAGRAM RECEIVER SIGNAL FLOW

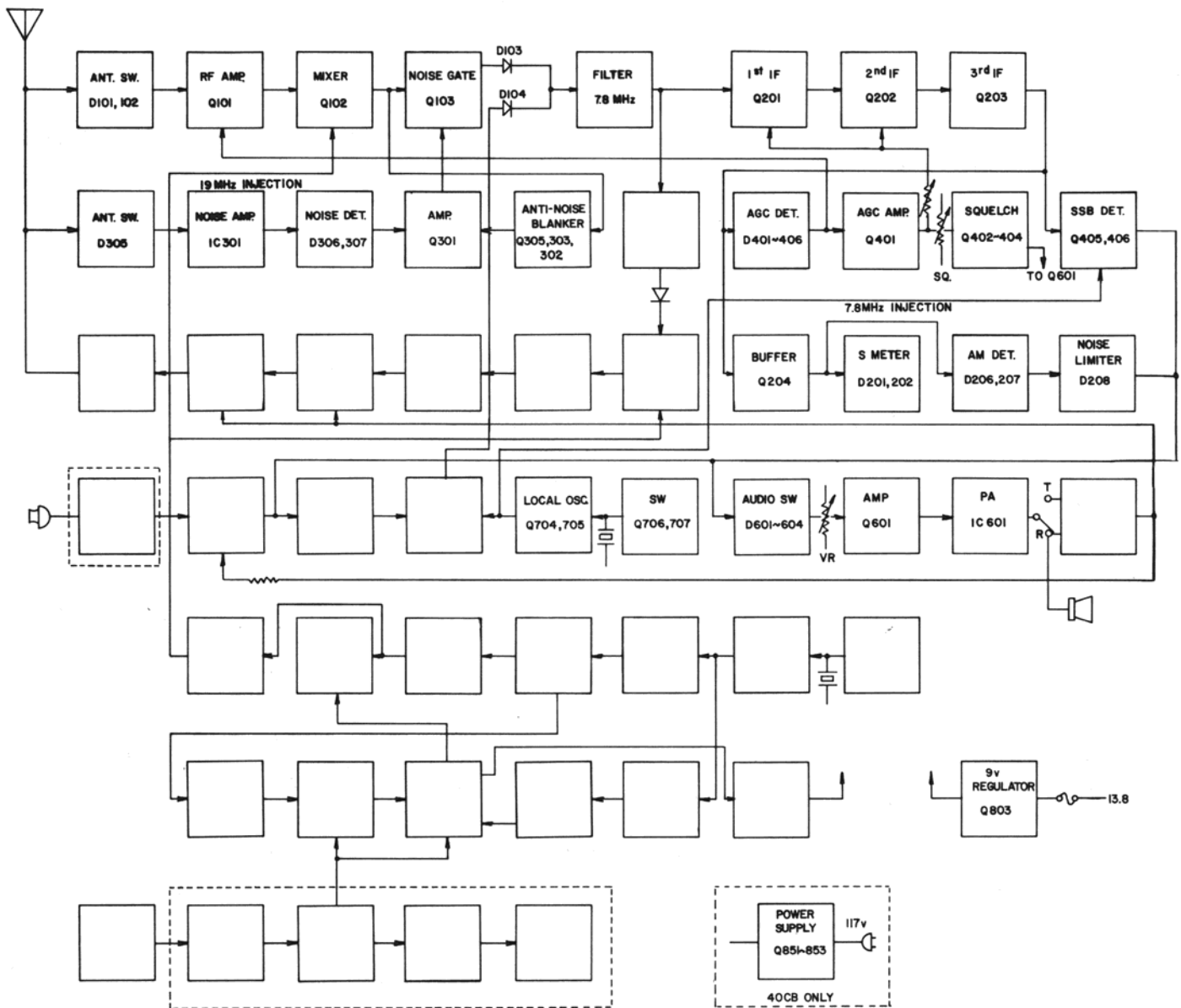

# BLOCK DIAGRAM TRANSMIT SIGNAL FLOW

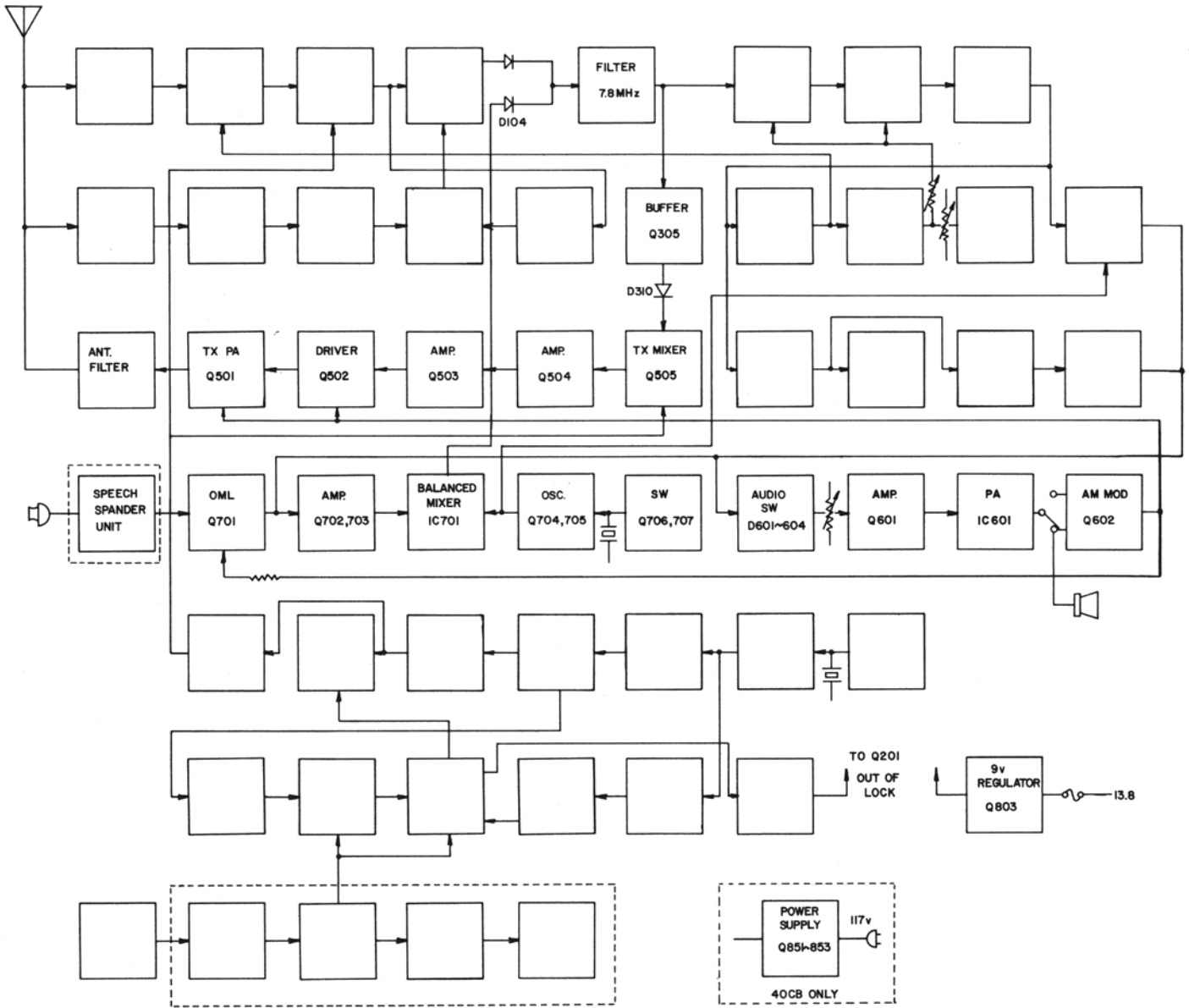

# BLOCK DIAGRAM PLL SIGNAL FLOW

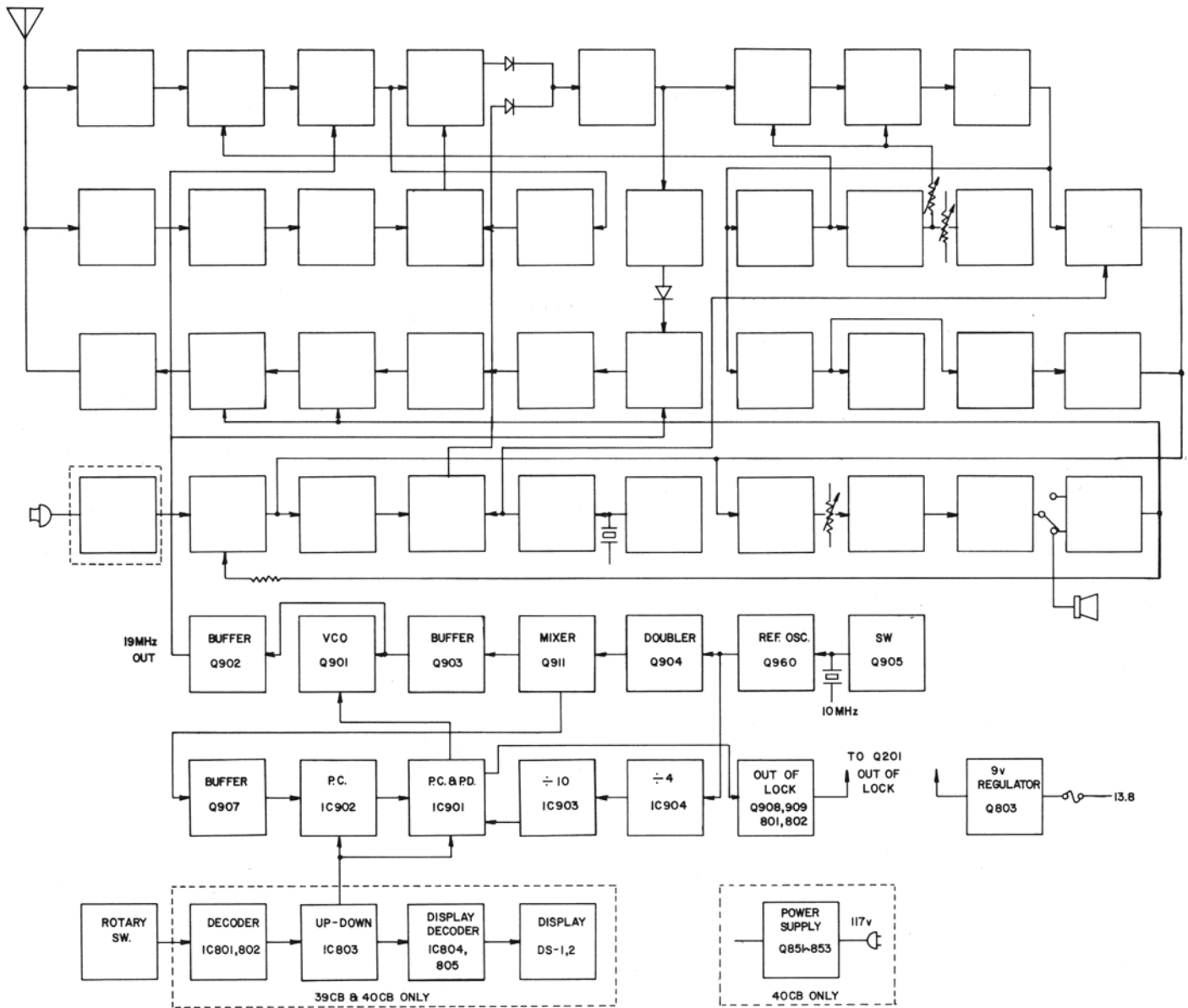

# SYNTHESIZER SCHEMATIC

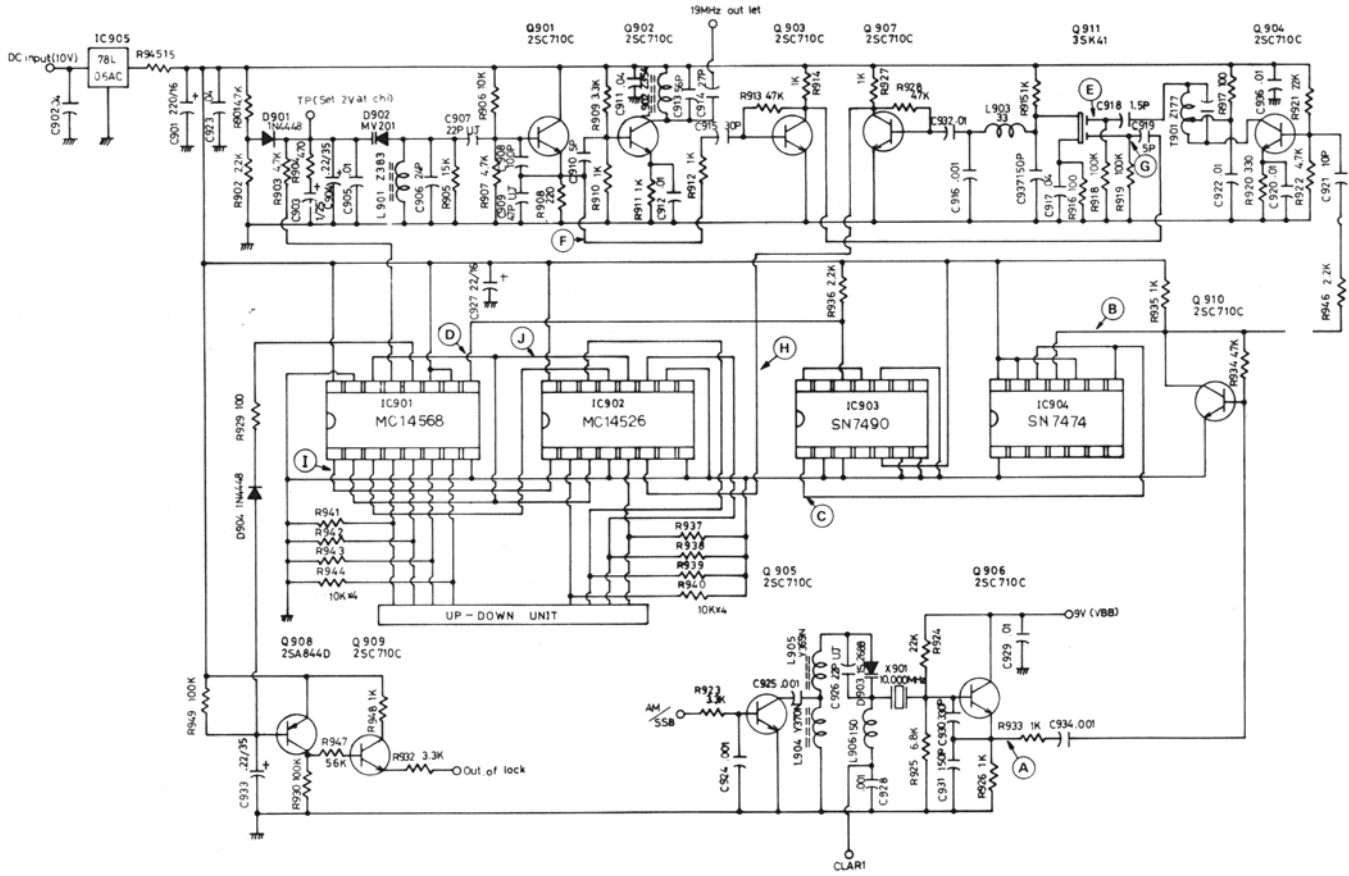

## SYNTHESIZER WAVEFORMS

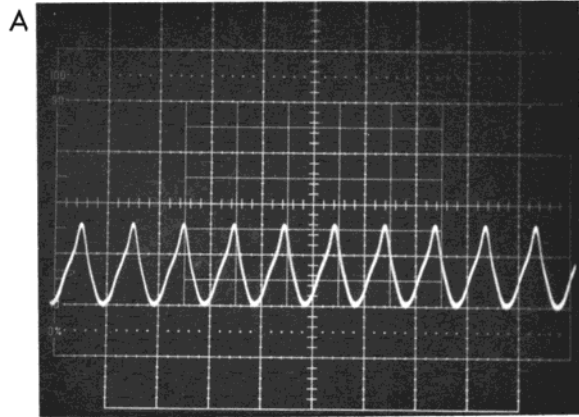

VERTICAL: 0.1vpc,  
HORIZONTAL: 0.1us, FREQ: 10.0 MHZ

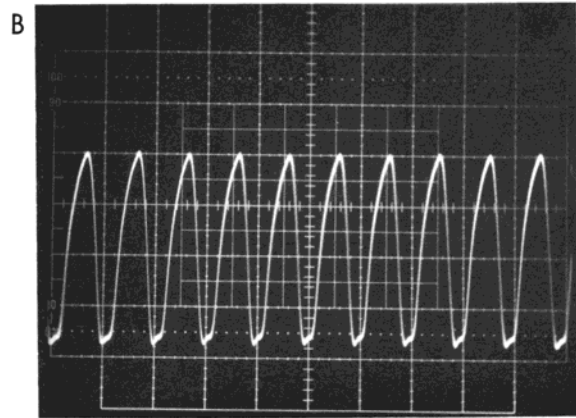

VERTICAL: 0.1vpc,  
HORIZONTAL: 0.1us, FREQ: 10.0 MHZ

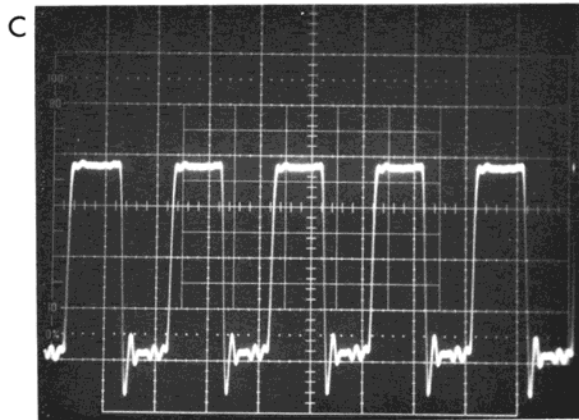

VERTICAL: 0.1vpc,  
HORIZONTAL: 0.1us, FREQ: 5.0 MHZ

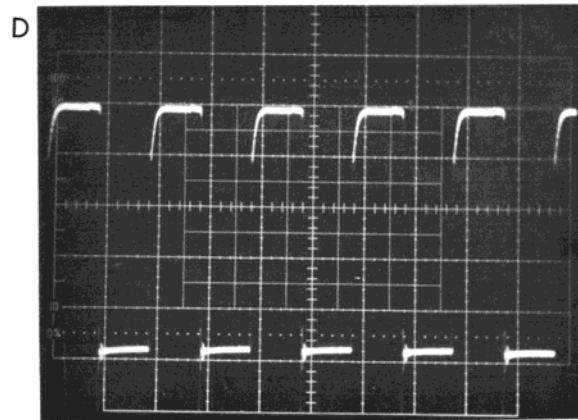

VERTICAL: 0.1vpc,  
HORIZONTAL: 1.0us, FREQ: 500 KHZ

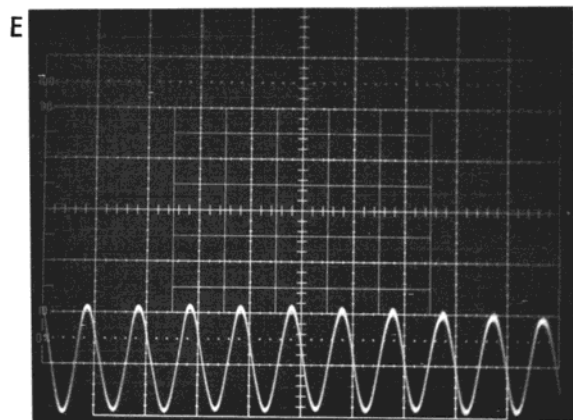

VERTICAL: 20 mvpc,  
HORIZONTAL: 0.05us, FREQ: 20 MHZ

All waveforms taken with 10x1 probe scope  
vertical in DC mode with o ref line 1cm  
from bottom.

Radio controls as follows  
Mode - AM Rx  
Ch - 20  
Clarifier - center

## SYNTHESIZER WAVEFORMS

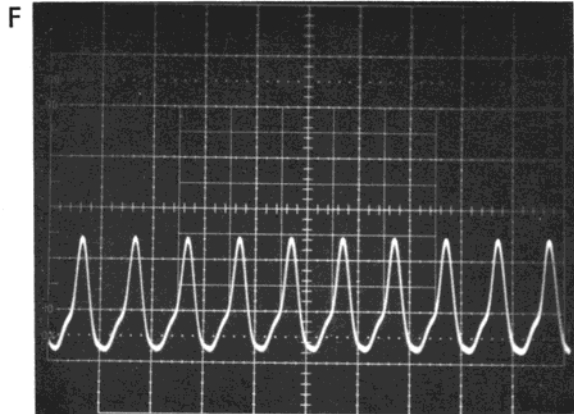

VERTICAL: 0.1vpc,  
HORIZONTAL: 0.05 $\mu$ s, FREQ: 19.405 MHz

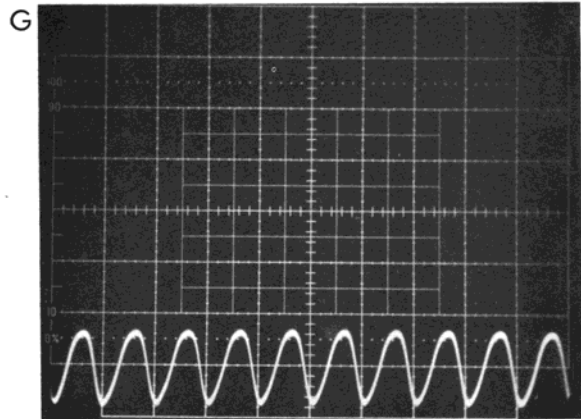

VERTICAL: 0.05 vpc,  
HORIZONTAL: 0.05 $\mu$ s, FREQ: 19.405 MHz

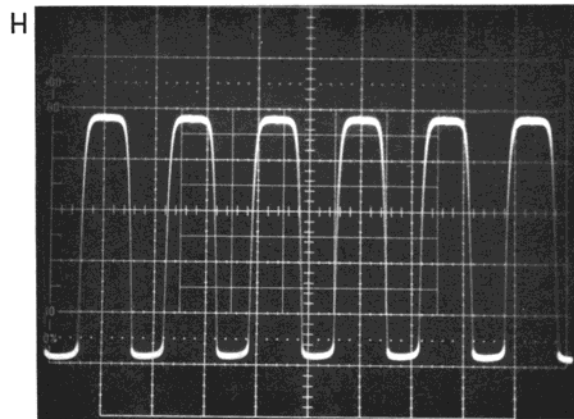

VERTICAL: 0.1vpc,  
HORIZONTAL: 1.0 $\mu$ s, FREQ: 595 KHZ

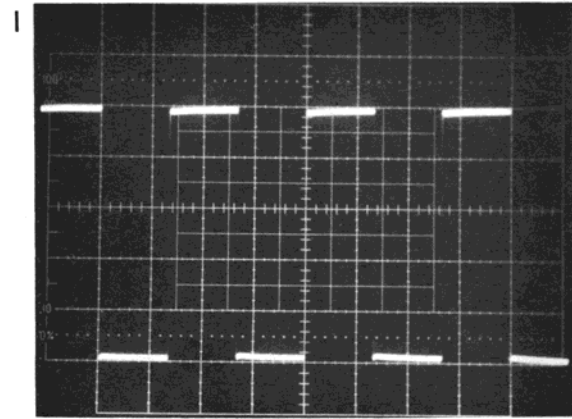

VERTICAL: 0.1vpc,  
HORIZONTAL: 10.0 $\mu$ s, FREQ: 35 KHZ

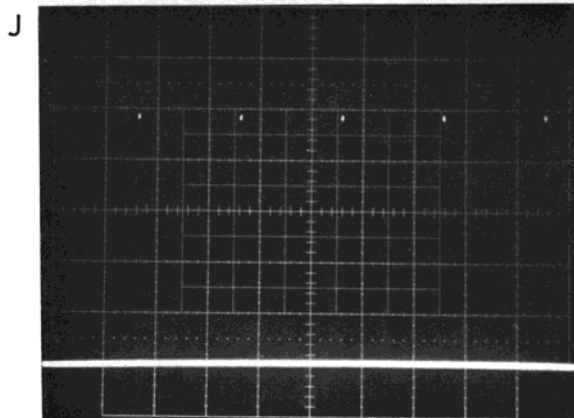

VERTICAL: 0.1vpc,  
HORIZONTAL: 0.1ms, FREQ: 5 KHZ

All waveforms taken with 10x1 probe scope  
vertical in DC mode with o ref line 1cm  
from bottom.

Radio controls as follows  
Mode - AM Rx  
Ch - 20  
Clarifier - center







# COMPONENT ALIGNMENT LOCATION

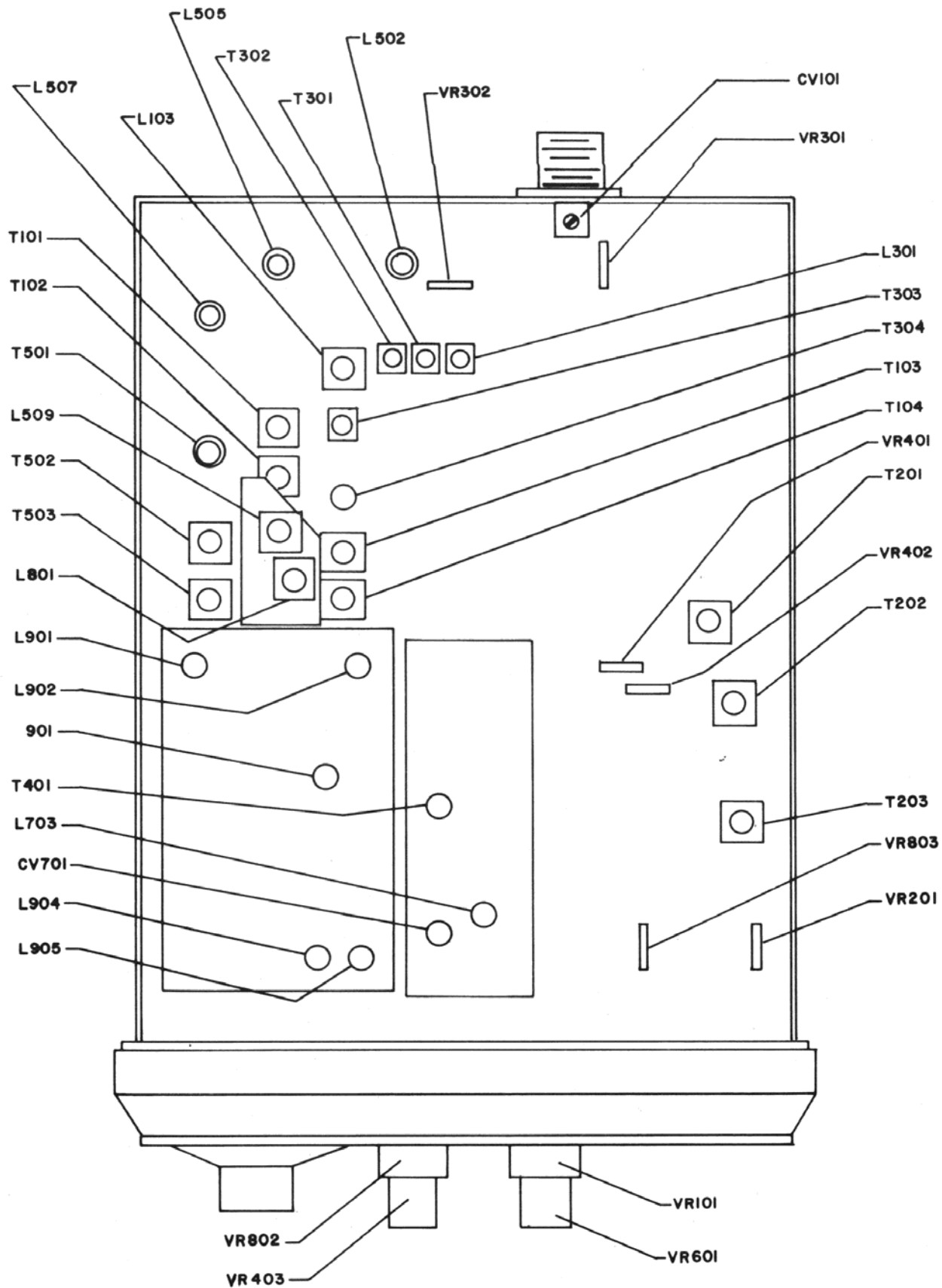





# COMPONENT ALIGNMENT LOCATION

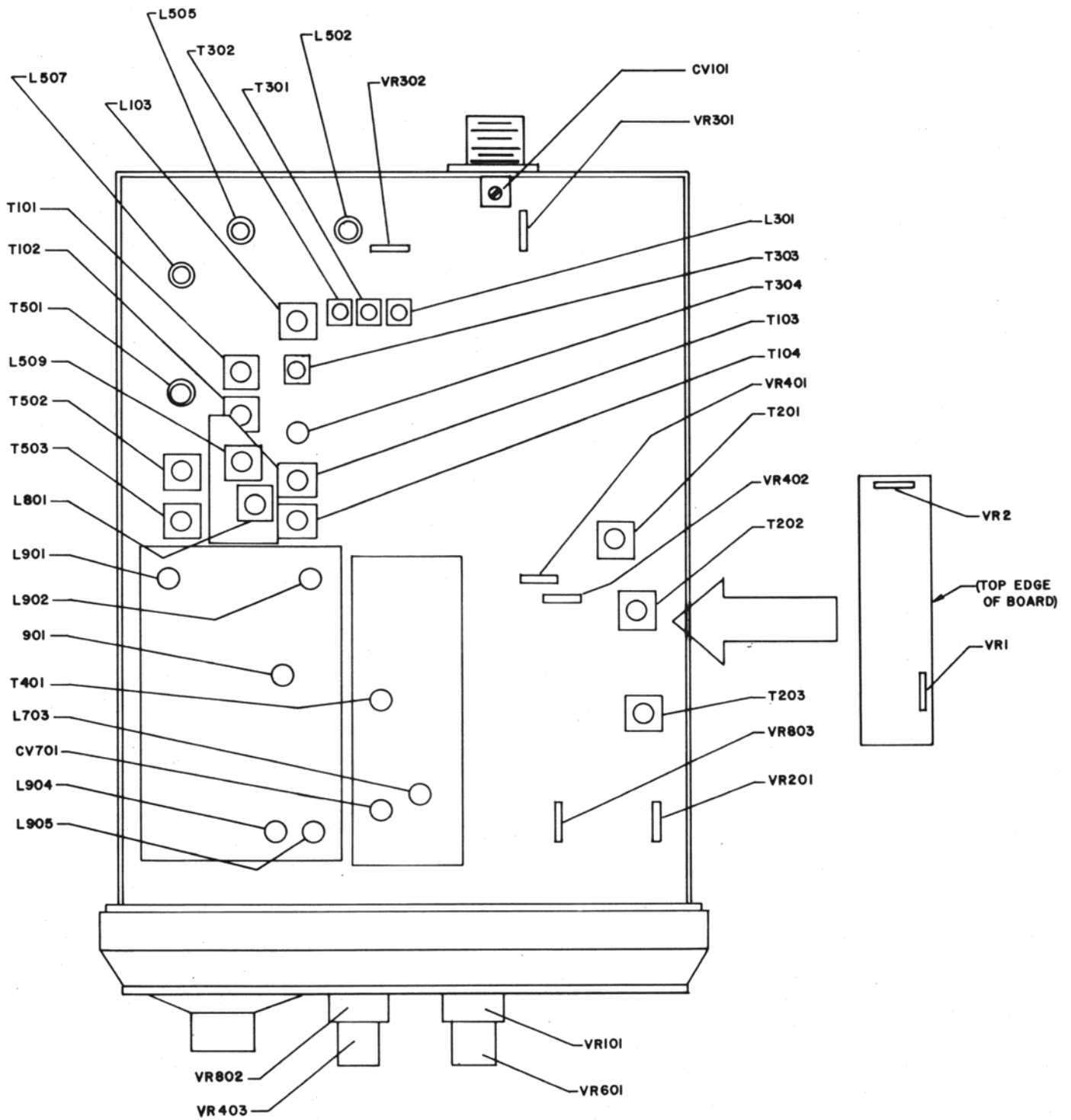

COMPONENT ALIGNMENT LOCATION  
TOP VIEW SBE-40CB

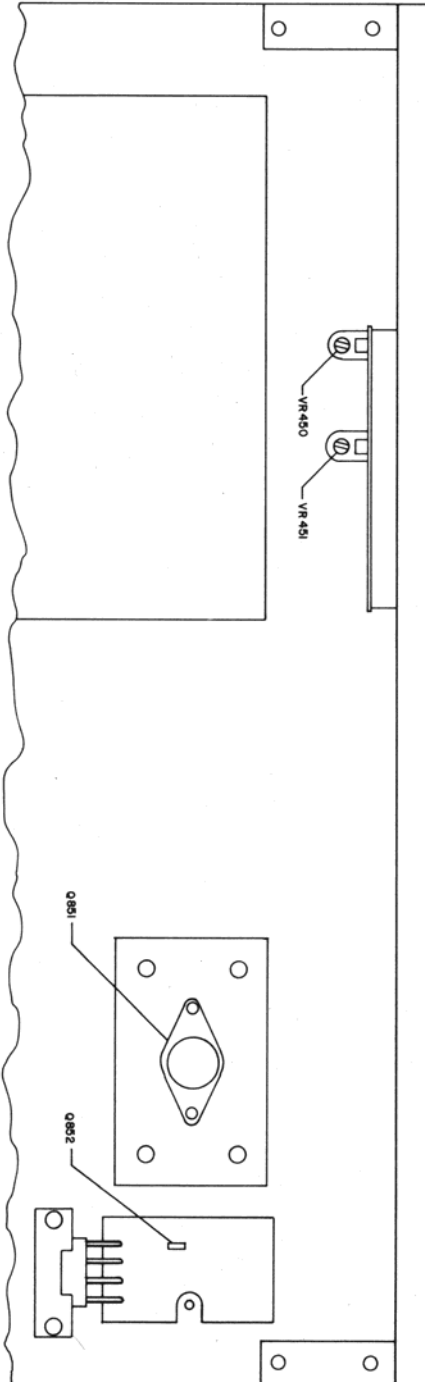

# COMPONENT LAYOUT LOCATION BOTTOM VIEW SBE-40CB

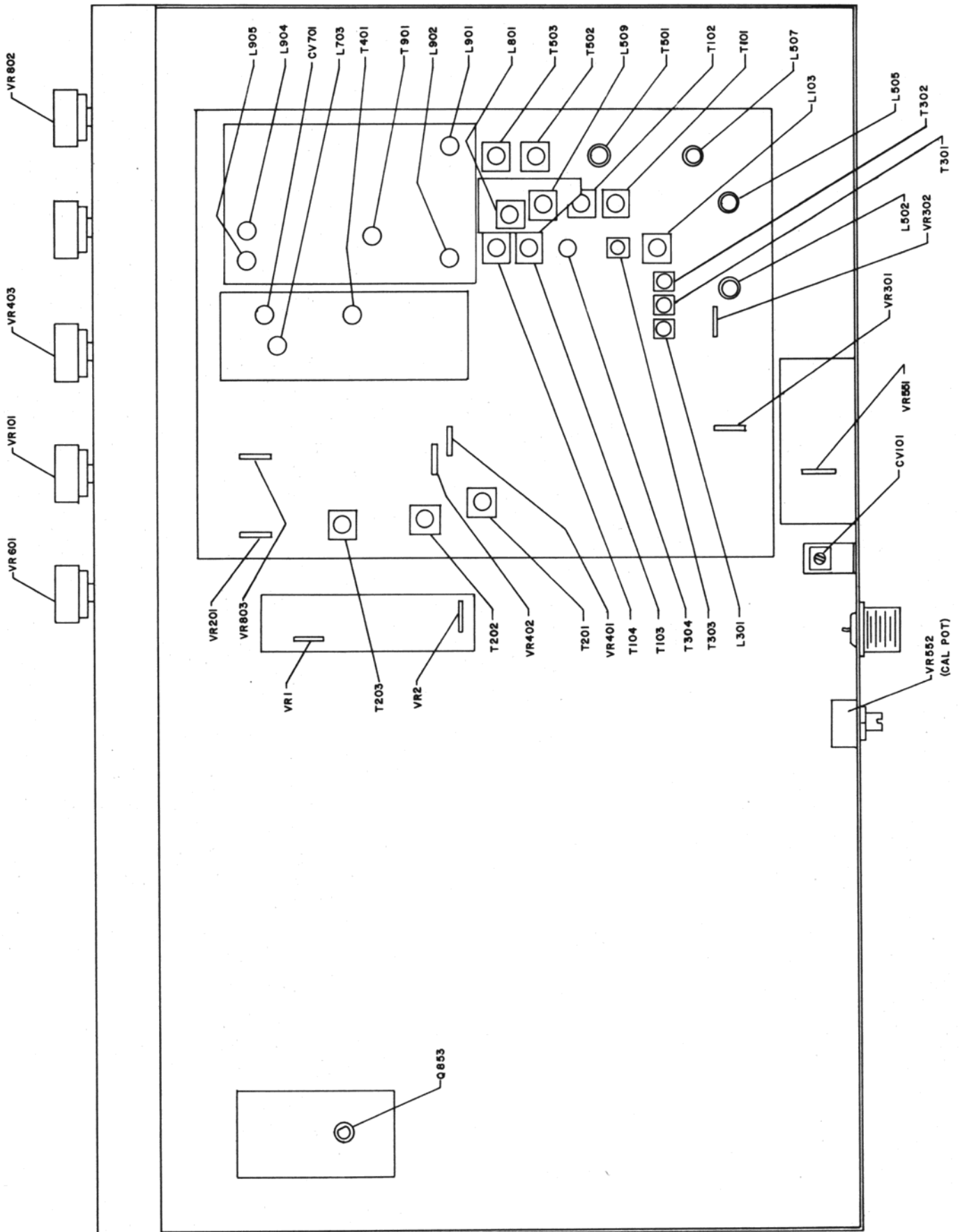

## SPEECH SPANDER SCHEMATIC

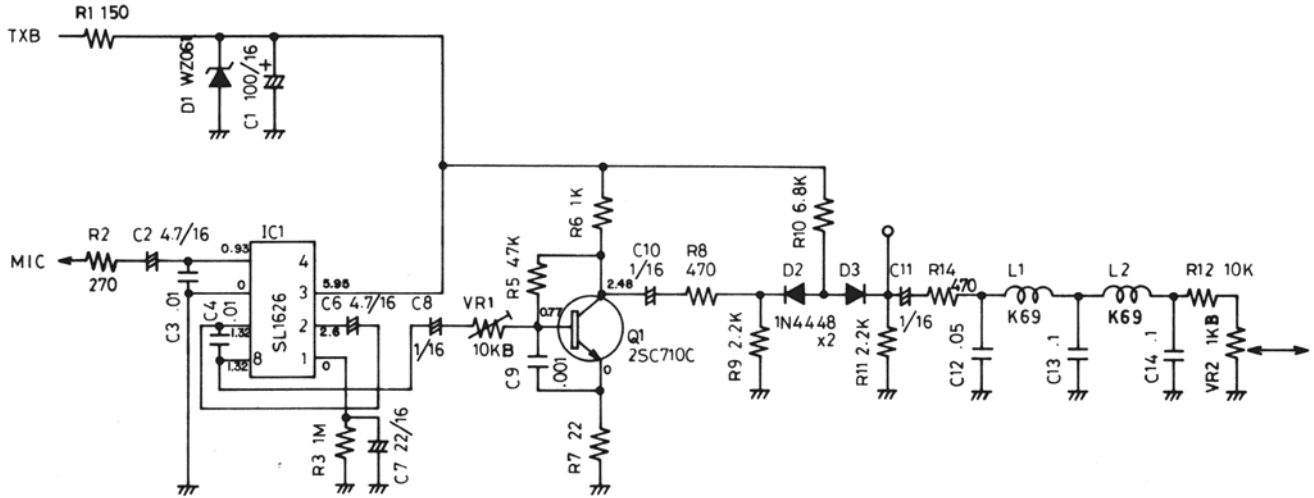

HIGHEST NO.	VACANT
R 14	R 4
VR 2	R 13
C 14	C 5
Q 1	
D 3	
IC-1	

## SPEECH SPANDER COMPONENT LOCATION

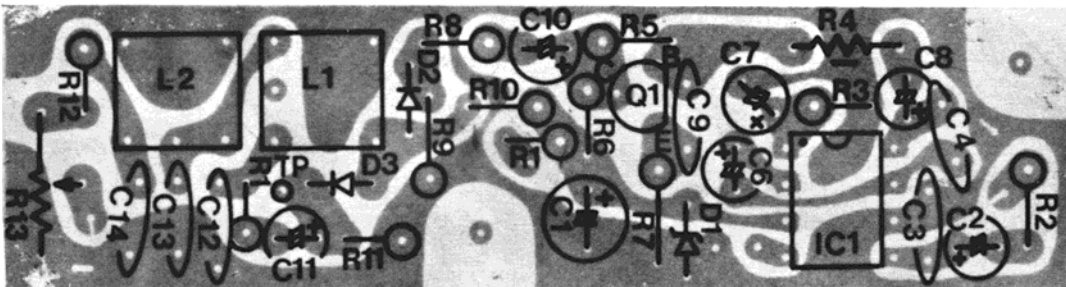

# UP-DOWN UNIT SCHEMATIC

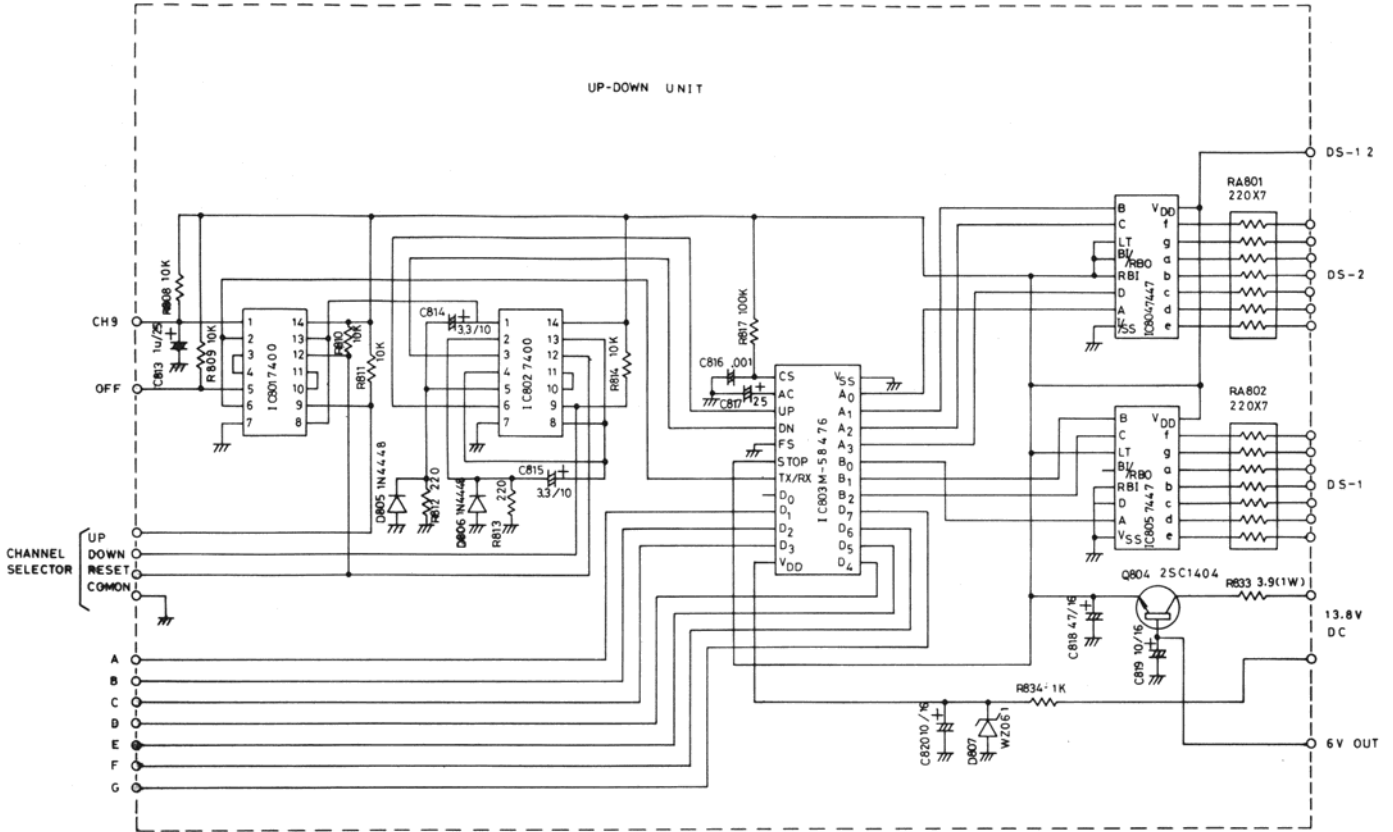



# SCHEMATIC DIAGRAM SBE-27CB/A

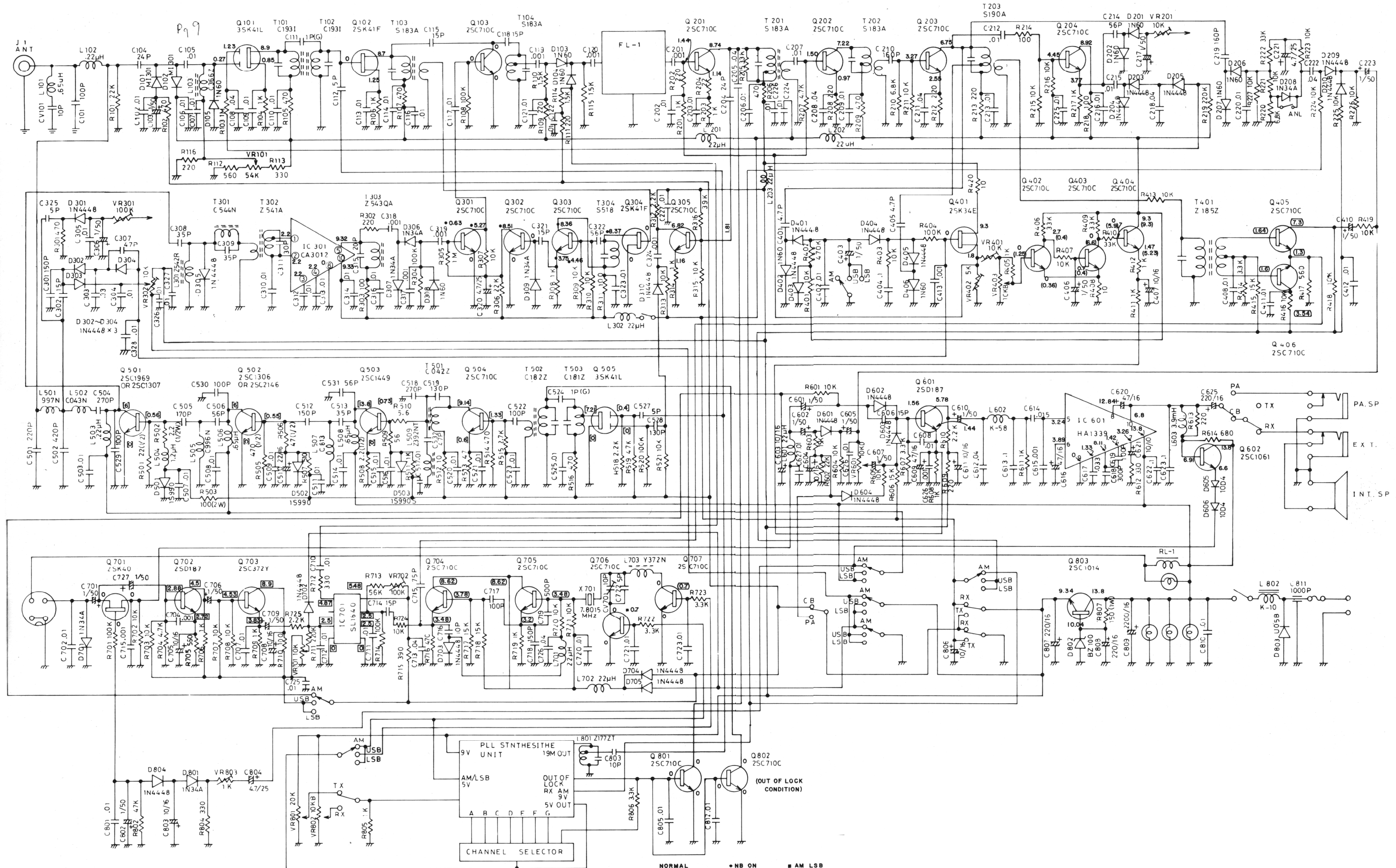

( ) SQUELCHED ( ) USB  
 [ ] TX □ TX USB  
 \* NB ON ■ AM LSB

