

CS IMPORT

Zone Industrielle B.P.36 - 34540 BALARUC
Tél: (67) 53.22.88 - Télex: 490 534 F

**1011001, McKinley.
40 Canaux.**

AM.FM . SSB.



**Manuel Technique
de Maintenance**

EURO PRESIDENT

A

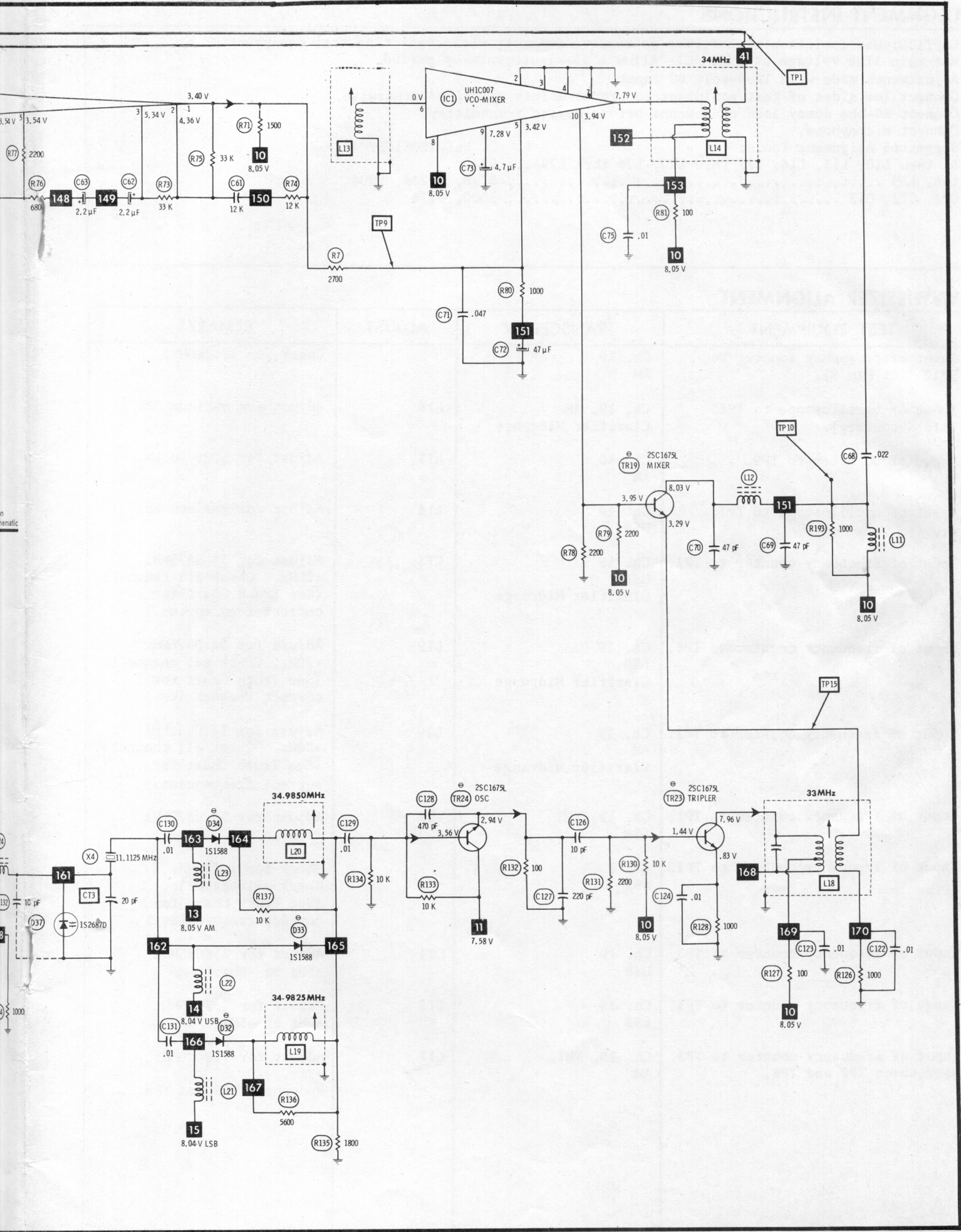

ALIGNMENT INSTRUCTIONS

CAUTION: Use isolation transformer or observe polarity when connecting test equipment. Maintain line voltage at 120V AC. Allow a 15-minute warm-up period.
 Adjustments made with 13.8-volt DC input.
 Connect low sides of test equipment to ground unless specified otherwise.
 Connect 50-ohm dummy load or antenna before keying transmitter.
 Connect microphone.
 Suggested Alignment Tools: GC ELECTRONICS:
 L1 thru L10, L13, L14, L17 thru L20, L26 thru L29 ... 9440
 L36, L39 8728, 8728A, 9304
 CT1, CT2, CT3 5000, 8276

SYNTHESIZER ALIGNMENT

TEST EQUIPMENT	TRANSCIVER	ADJUST	REMARKS
Input of frequency counter to TP12 (IC2 Pin 8).	Ch. 19 AM		Check for 10.240MHz.
Input of oscilloscope to TP15 (L18 Secondary).	Ch. 19, AM Clarifier Midrange	L18	Adjust for maximum RF.
Input of DC meter to TP9.	Ch. 40 AM	L13	Adjust for 5.00 volts.
Input of oscilloscope to TP1.	Ch. 19 USB	L14	Adjust for maximum RF.
Input of frequency counter to TP1.	Ch. 19 USB Clarifier Midrange	CT3	Adjust for 34.9875MHz +20Hz. Check all channels. (See Truth Chart for correct frequencies.)
Input of frequency counter to TP1.	Ch. 19 LSB Clarifier Midrange	L19	Adjust for 34.9825MHz +20Hz. Check all channels. (See Truth Chart for correct frequencies.)
Input of frequency counter to TP1.	Ch. 19 AM Clarifier Midrange	L20	Adjust for 34.9850MHz +20Hz. Check all channels. (See Truth Chart for correct frequencies.)
Input of frequency counter to TP1.	Ch. 19, XMT LSB	VR3	Adjust for 34.9825MHz +20Hz.
Input of frequency counter to TP10.	Ch. 1 USB		Check for 1.430MHz. Check all channels. (See Truth Chart for correct frequencies.)
Input of frequency counter to TP3.	Ch. 19 USB	CT1	Adjust for 7.8025MHz +5Hz or -0Hz.
Input of frequency counter to TP3.	Ch. 19 LSB	CT2	Adjust for 7.7975MHz +0Hz or -5Hz.
Input of frequency counter to TP3. Disconnect TP7 and TP8.	Ch. 19, XMT AM	L17	Adjust for 7.8000MHz +5Hz. Reconnect TP7 and TP8.

RECEIVER ALIGNMENT

Connect an AC VTVM or AF wattmeter across speaker voice coil.
 Adjust volume control to obtain a suitable indication.
 Set generator output low enough to prevent AGC limiting.
 Mode AM, RF Gain maximum, Squelch MINIMUM, Clarifier Midrange, NB Off.

AM

TEST EQUIPMENT	TRANSCEIVER	ADJUST	REMARKS
Output of signal generator thru .01uF to TP13 (TR10 Collector). 7.8MHz, 1000Hz @ 30% modulation.	Ch. 19	L3,L4	Adjust for maximum output.
Output of signal generator thru .01uF to antenna input. 27.185MHz,1000Hz @ 30% modulation.	Ch. 19	L5,L6,L7, L8,L9,L10	Adjust for maximum output. If necessary readjust L3 and L4 for maximum.
Output of signal generator thru .01uF to antenna input. 27.185MHz,1000Hz @ 30% modulation.	Ch. 19	L1,L2	Set generator output for 10db signal to noise plus noise ratio of receiver. Inject a 100pps, 1uSec. pulse width signal at antenna input. Switch Noise Blanker on and adjust for maximum amplitude pulses.
Input of oscilloscope to TP14 (TR6 Emitter).			

RECEIVER ALIGNMENT

Connect an AC VTVM or AF wattmeter across speaker voice coil.
 Adjust volume control to obtain a suitable indication.
 Set generator output low enough to prevent AGC limiting.
 Mode USB, RF Gain Maximum, Squelch MINIMUM, Clarifier Midrange, NB Off.

SSB

TEST EQUIPMENT	TRANSCEIVER	ADJUST	REMARKS
Output of signal generator thru .01uF to TP13 (TR10 Collector). 7.8025MHz, no modulation.	Ch. 19	L3,L4	Adjust for maximum output.
Output of signal generator thru .01uF to antenna input. 27.186MHz, no modulation.	Ch. 19	L5,L6,L7, L8,L9,L10	Adjust for maximum output. If necessary readjust L3 and L4 for maximum.

RECEIVER ADJUSTMENTS

Connect an AC VTVM or AF wattmeter across speaker voice coil.
 Adjust volume control to obtain a suitable indication.
 Mode AM, RF Gain Maximum, Squelch MINIMUM, Clarifier Midrange, NB Off.

TEST EQUIPMENT	TRANSCEIVER	ADJUST	REMARKS
Output of signal generator thru .01uF to antenna input. 27.185MHz,1000Hz @ 30% modulation. Output 1000uV.	Ch. 19 Squelch Maximum	VR2	SQUELCH RANGE Adjust so that squelch just breaks.
Output of signal generator thru .01uF to antenna input. 27.185MHz,1000Hz @ 30% modulation. Output 100uV.	Ch. 19	VR1	SIG METER Adjust for 9 on SIG scale of meter.

TRANSMITTER ALIGNMENT

Connect an RF wattmeter and 50-ohm, 25-watt dummy load to antenna connector.
 NOTE: Be sure to check transmit frequency and power on all active channels after alignment of transmitter.
 See page 4 for channel frequencies.

TEST EQUIPMENT	TRANSCEIVER	ADJUST	REMARKS
Input of RF wattmeter and 50-ohm, 25 watt dummy load to antenna input. Inject a two tone 50mV signal at MIC input.	Ch. 19 USB Mike Gain Maximum	L26,L27, L28,L29, L36	Set VR7 to MINIMUM. Adjust for maximum RF output.
Input of spectrum analyzer or harmonic meter to antenna input.	Ch. 19 AM Mike Gain MINIMUM	L39	Adjust for MINIMUM at 54MHz (2nd harmonic).

TRANSMITTER ADJUSTMENTS

Connect an RF wattmeter and 50-ohm, 25-watt dummy load to antenna connector.
 NOTE: Be sure to check transmit frequency and power on all active channels after adjustment of transmitter.
 See page 4 for channel frequencies.

TEST EQUIPMENT	TRANSCEIVER	ADJUST	REMARKS
Insert a 0-150mA DC current meter at TP8. No modulation.	Ch. 19 USB Mike Gain MINIMUM	VR8	RF DRIVER BIAS Adjust for 35mA idle current. Reconnect TP8.
Insert a 0-150mA DC current meter at TP7. No modulation.	Ch. 19 USB Mike Gain MINIMUM	VR9	RF FINAL BIAS Adjust for 45mA idle current. Reconnect TP7.
Input of RF wattmeter and 50-ohm, 25 watt dummy load to antenna input. No modulation.	Ch. 19 USB Mike Gain MINIMUM	VR5	CARRIER BALANCE Adjust for MINIMUM RF output. Check LSB and readjust if necessary for MINIMUM RF output.
Input of RF wattmeter and 50-ohm, 25-watt dummy load to antenna input. Inject a two tone, 50mV signal at MIC input.	Ch. 19 USB Mike Gain Maximum	VR7	RF ALC Adjust for 11.0 watts PEP RF output maximum.
Input of RF wattmeter and 50-ohm, 25 watt dummy load to antenna input. No modulation.	Ch. 19, AM Mike Gain MINIMUM	VR6	AM POWER Adjust for 4.0 watts RF output maximum.
Input of RF wattmeter and 50-ohm, 25 watt dummy load to antenna input. No modulation.	Ch. 19, AM Mike Gain MINIMUM	VR10	TX PWR METER Adjust so that PWR Meter agrees with RF wattmeter.

TRUTH CHART

C H A N N E L	1 = 7.98 Volts 0 = 0 Volts						DIVIDER INPUT IN MHz AT TP10	AM REC VCO OUTPUT IN MHz AT TP1	USB REC VCO OUTPUT IN MHz AT TP1	LSB REC VCO OUTPUT IN MHz AT TP1
	IC2 PROGRAM DIVIDER									
	PINS									
	11	12	13	14	15	16				
1	0	0	1	1	1	1	1.430	34.765	34.7675	34.7625
2	0	1	0	0	0	0	1.440	34.775	34.7775	34.7725
3	0	1	0	0	0	1	1.450	34.785	34.7875	34.7825
4	0	1	0	0	1	1	1.470	34.805	34.8075	34.8025
5	0	1	0	1	0	0	1.480	34.815	34.8175	34.8125
6	0	1	0	1	0	1	1.490	34.825	34.8275	34.8225
7	0	1	0	1	1	0	1.500	34.835	34.8375	34.8325
8	0	1	1	0	0	0	1.520	34.855	34.8575	34.8525
9	0	1	1	0	0	1	1.530	34.865	34.8675	34.8625
10	0	1	1	0	1	0	1.540	34.875	34.8775	34.8725
11	0	1	1	0	1	1	1.550	34.885	34.8875	34.8825
12	0	1	1	1	0	1	1.570	34.905	34.9075	34.9025
13	0	1	1	1	1	0	1.580	34.915	34.9175	34.9125
14	0	1	1	1	1	1	1.590	34.925	34.9275	34.9225
15	1	0	0	0	0	0	1.600	34.935	34.9375	34.9325
16	1	0	0	0	1	0	1.620	34.955	34.9575	34.9525
17	1	0	0	0	1	1	1.630	34.965	34.9675	34.9625
18	1	0	0	1	0	0	1.640	34.975	34.9775	34.9725
19	1	0	0	1	0	1	1.650	34.985	34.9875	34.9825
20	1	0	0	1	1	1	1.670	34.005	34.0075	35.0025
21	1	0	1	0	0	0	1.680	35.015	35.0175	35.0125
22	1	0	1	0	0	1	1.690	35.025	35.0275	35.0225
23	1	0	1	1	0	0	1.720	35.055	35.0575	35.0525
24	1	0	1	0	1	0	1.700	35.035	35.0375	35.0325
25	1	0	1	0	1	1	1.710	35.045	35.0475	34.0425
26	1	0	1	1	0	1	1.730	35.065	35.0675	35.0625
27	1	0	1	1	1	0	1.740	35.075	35.0775	35.0725
28	1	0	1	1	1	1	1.750	35.085	35.0875	35.0825
29	1	1	0	0	0	0	1.760	35.095	35.0975	35.0925
30	1	1	0	0	0	1	1.770	35.105	35.1075	35.1025
31	1	1	0	0	1	0	1.780	35.115	35.1175	35.1125
32	1	1	0	0	1	1	1.790	35.125	35.1275	35.1225
33	1	1	0	1	0	0	1.800	35.135	35.1375	35.1325
34	1	1	0	1	0	1	1.810	35.145	35.1475	35.1425
35	1	1	0	1	1	0	1.820	35.155	35.1575	35.1525
36	1	1	0	1	1	1	1.830	35.165	35.1675	35.1625
37	1	1	1	0	0	0	1.840	35.175	35.1775	35.1725
38	1	1	1	0	0	1	1.850	35.185	35.1875	35.1825
39	1	1	1	0	1	0	1.860	35.195	35.1975	35.1925
40	1	1	1	0	1	1	1.870	35.205	35.2075	35.2025

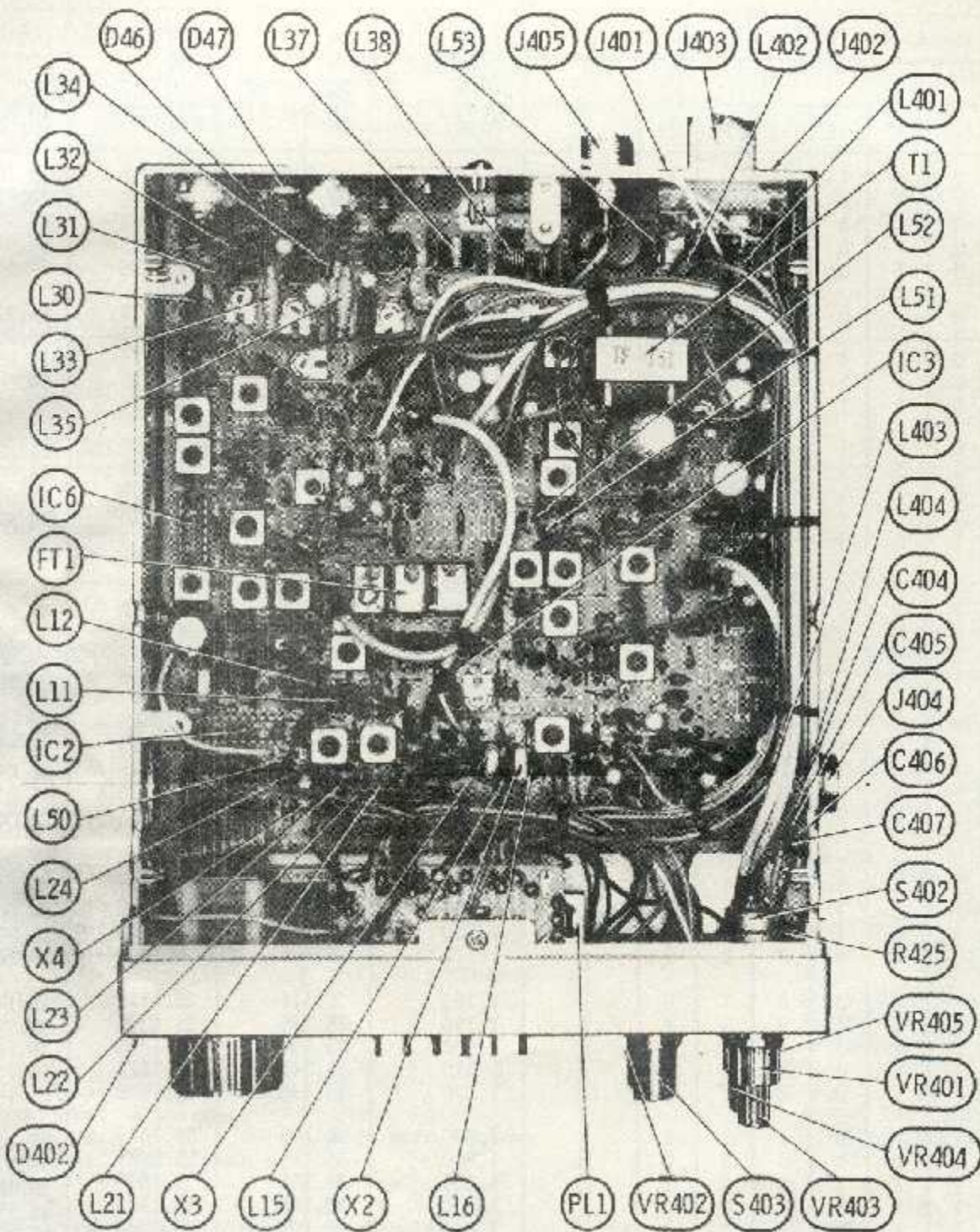

CHASSIS - BOTTOM

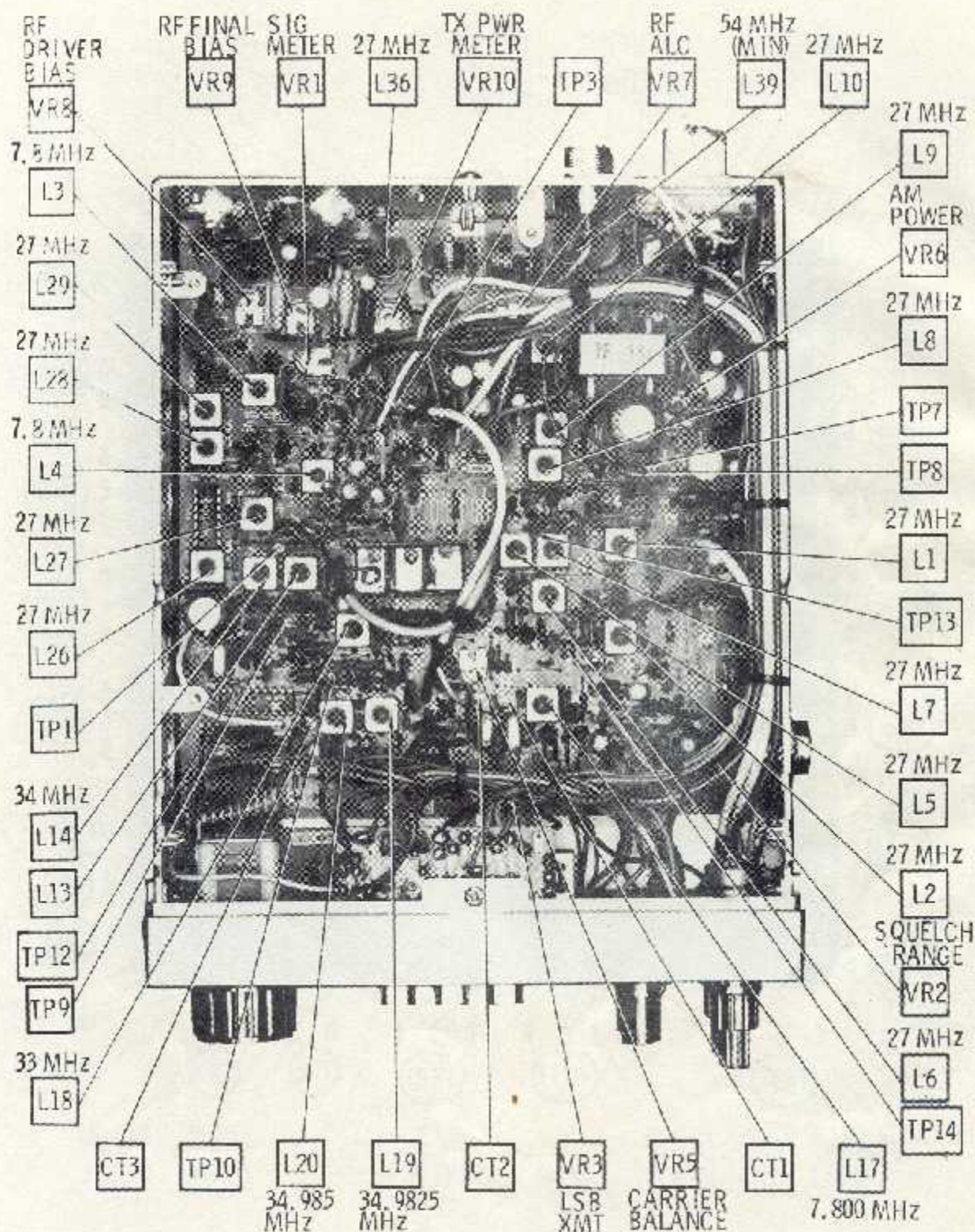

CHASSIS - BOTTOM

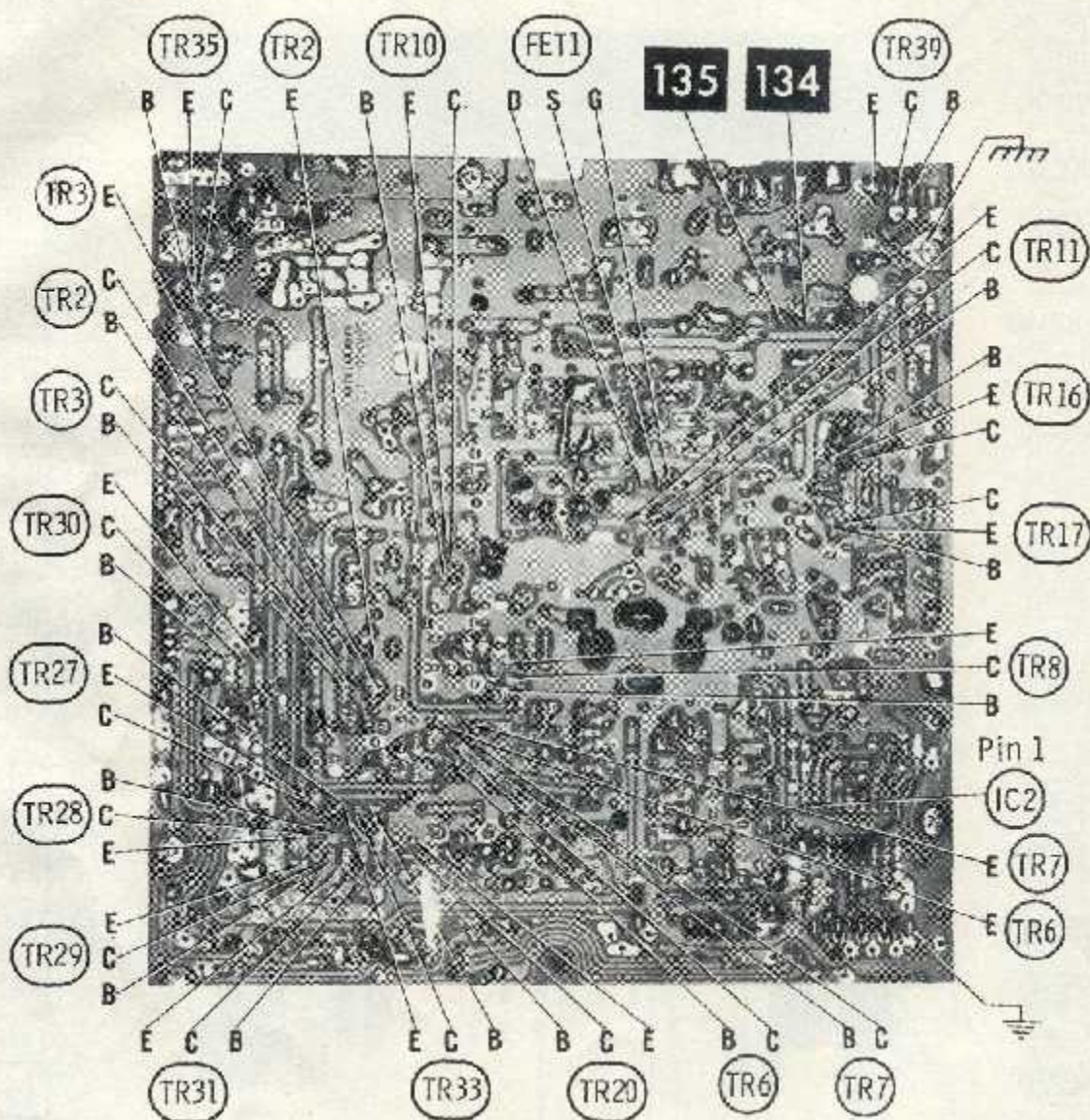

MAIN BOARD

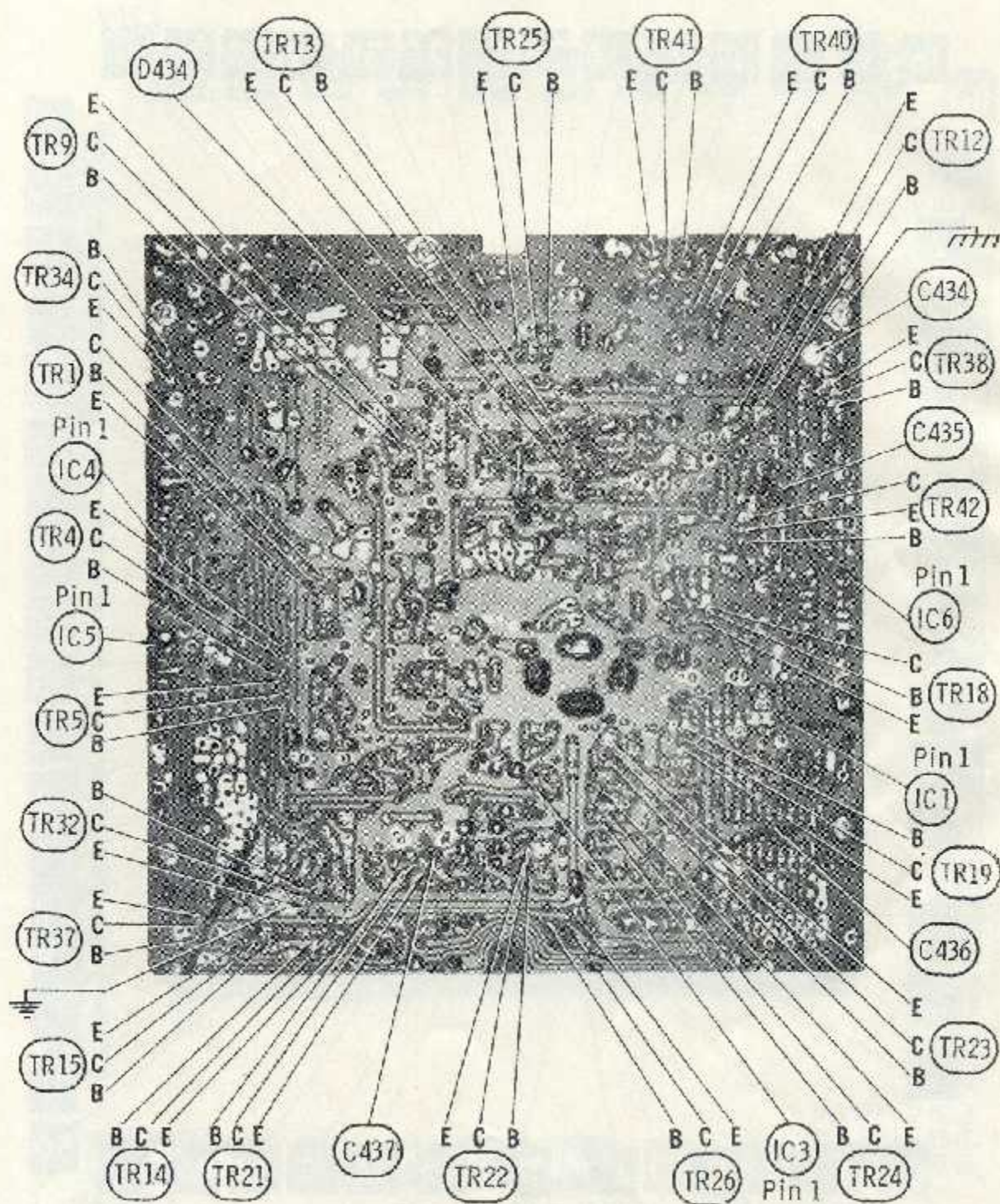

MAIN - BOARD

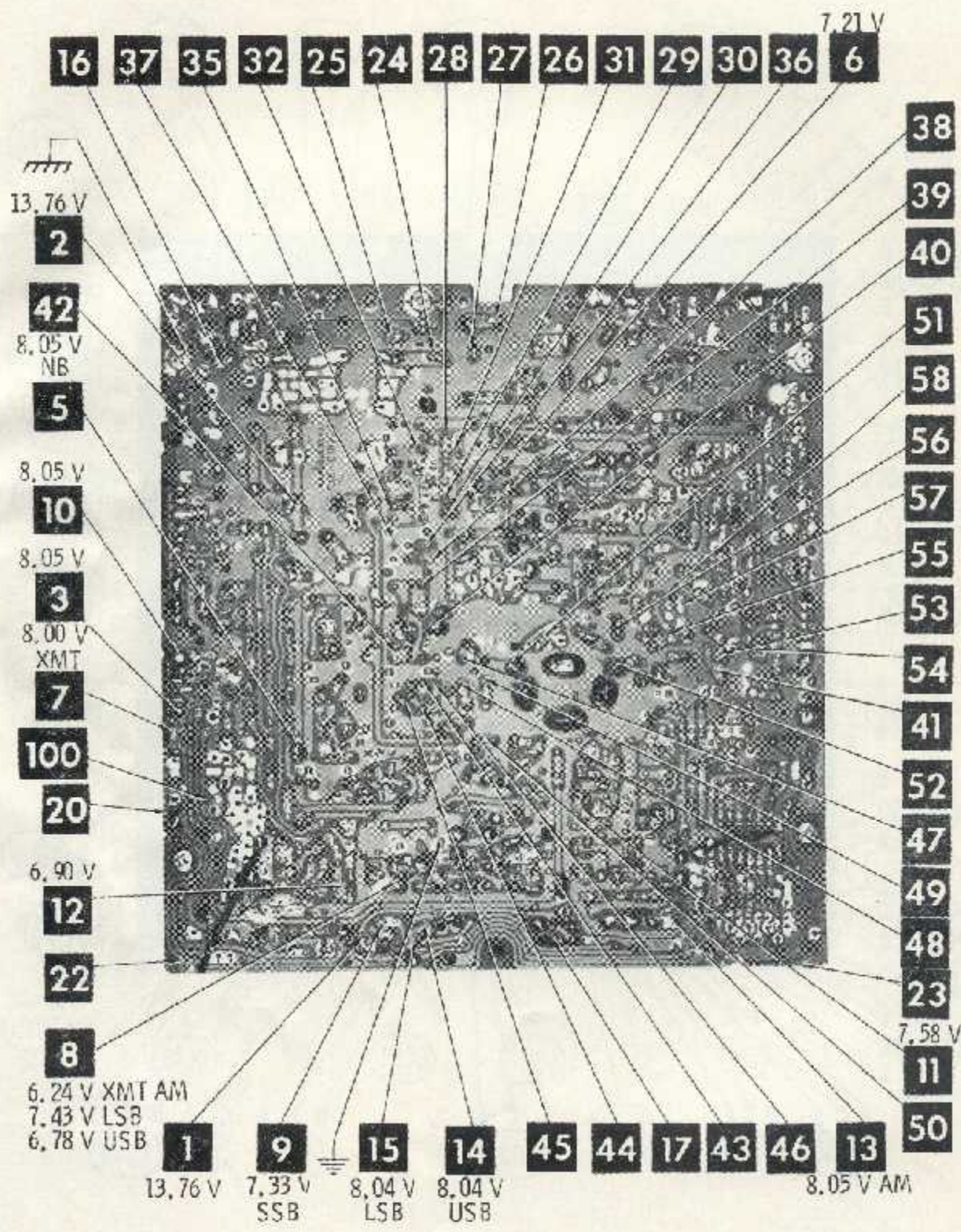

MAIN BOARD

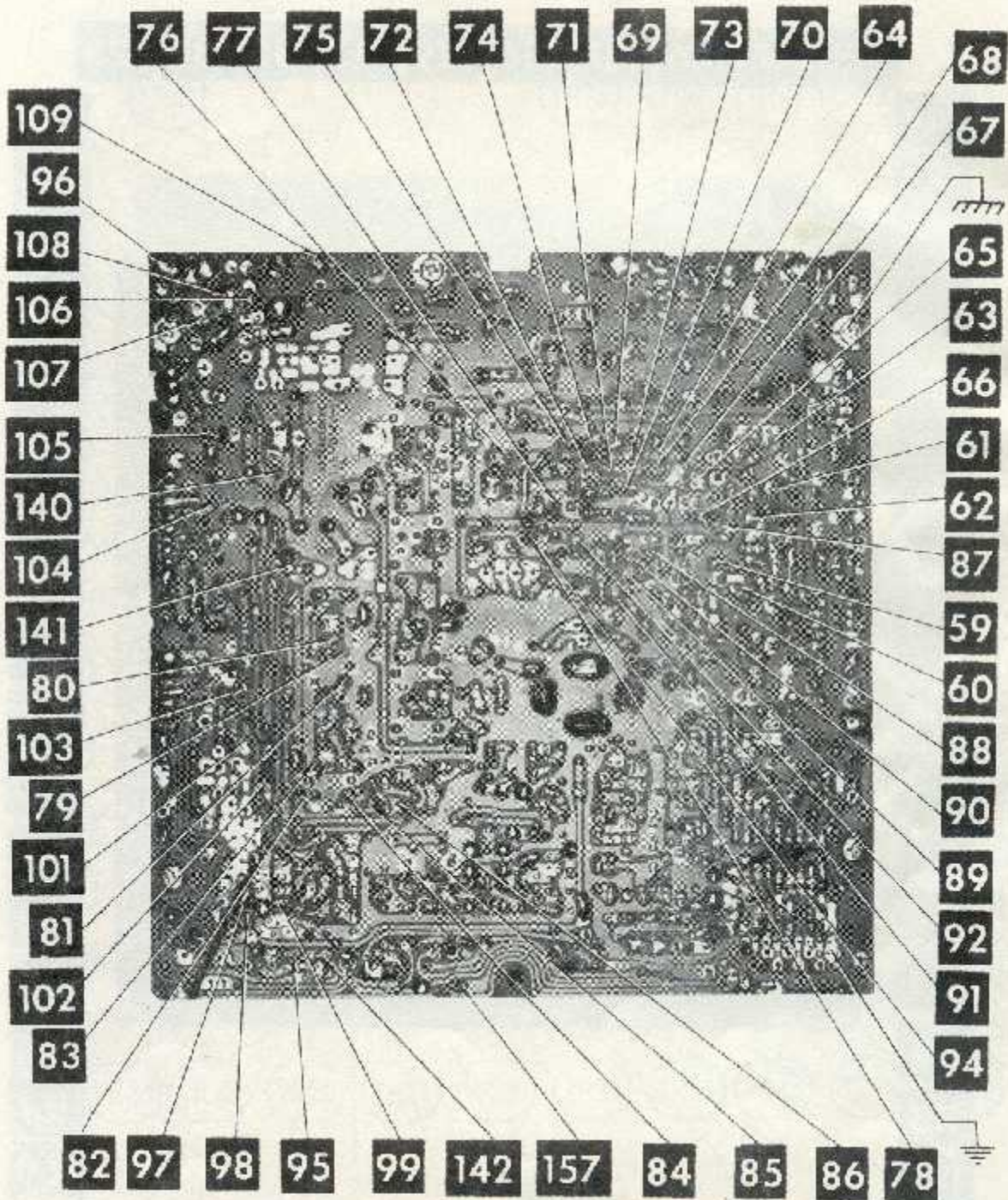

MAIN - BOARD

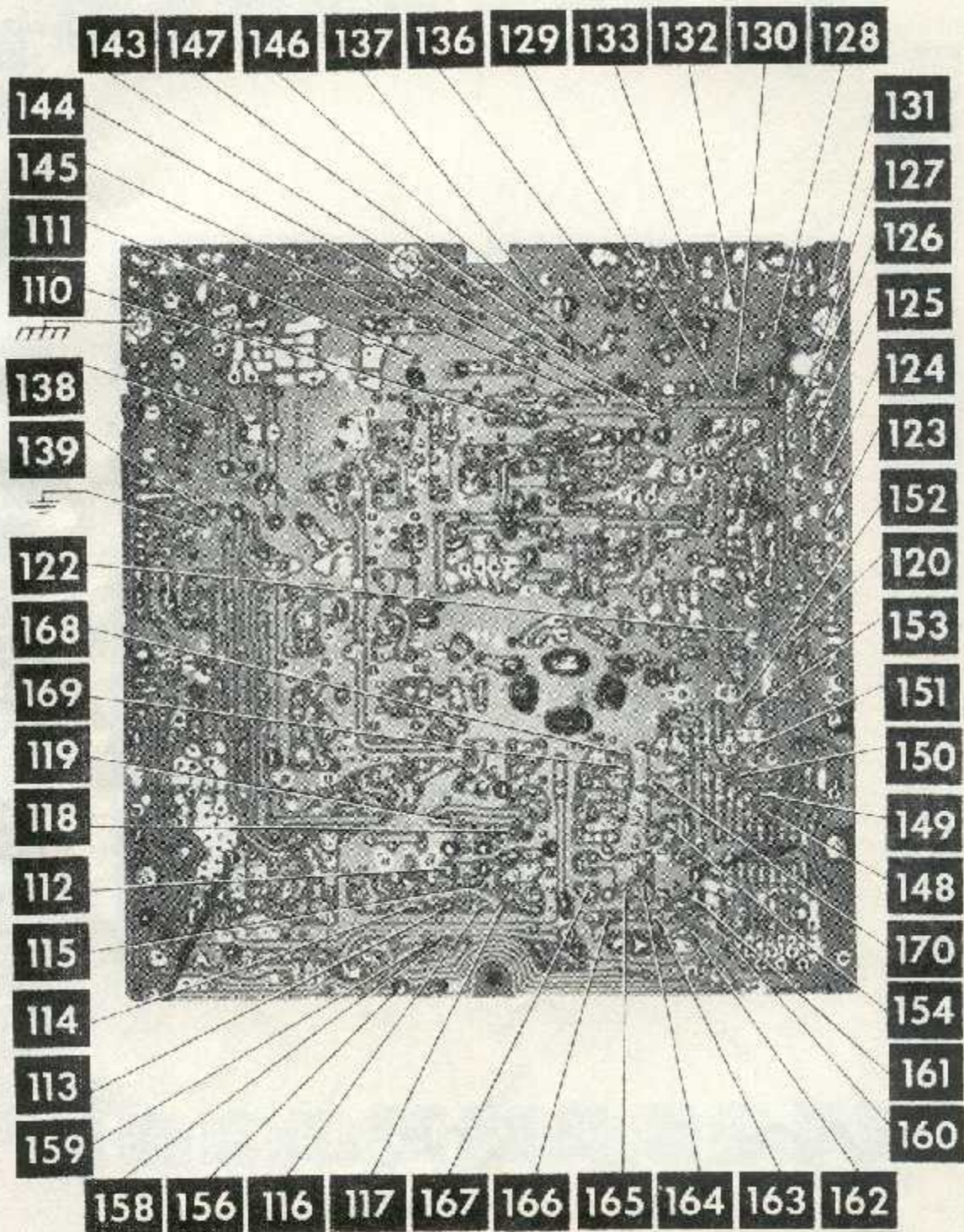

MAIN BOARD

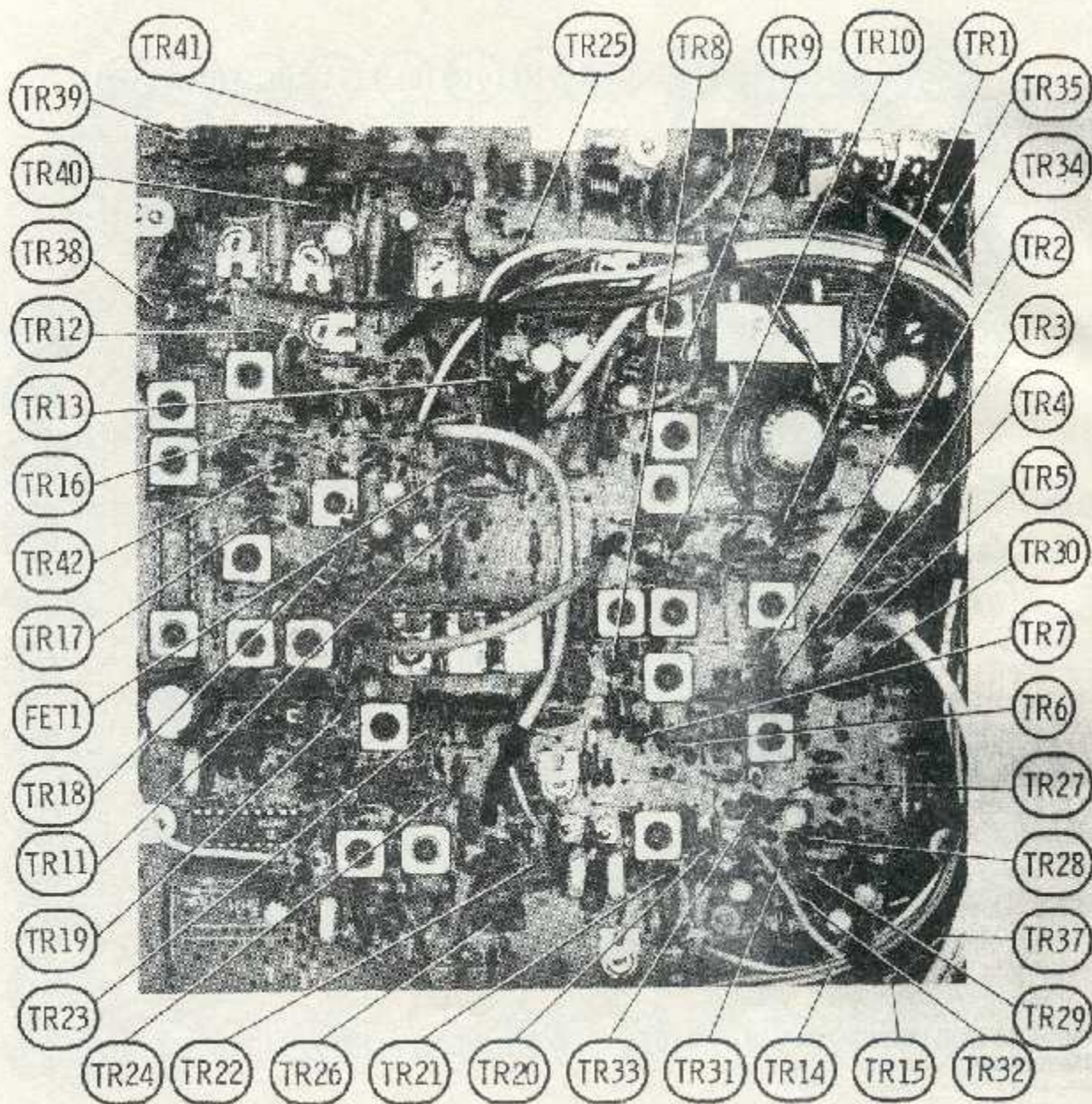

MAIN - BOARD

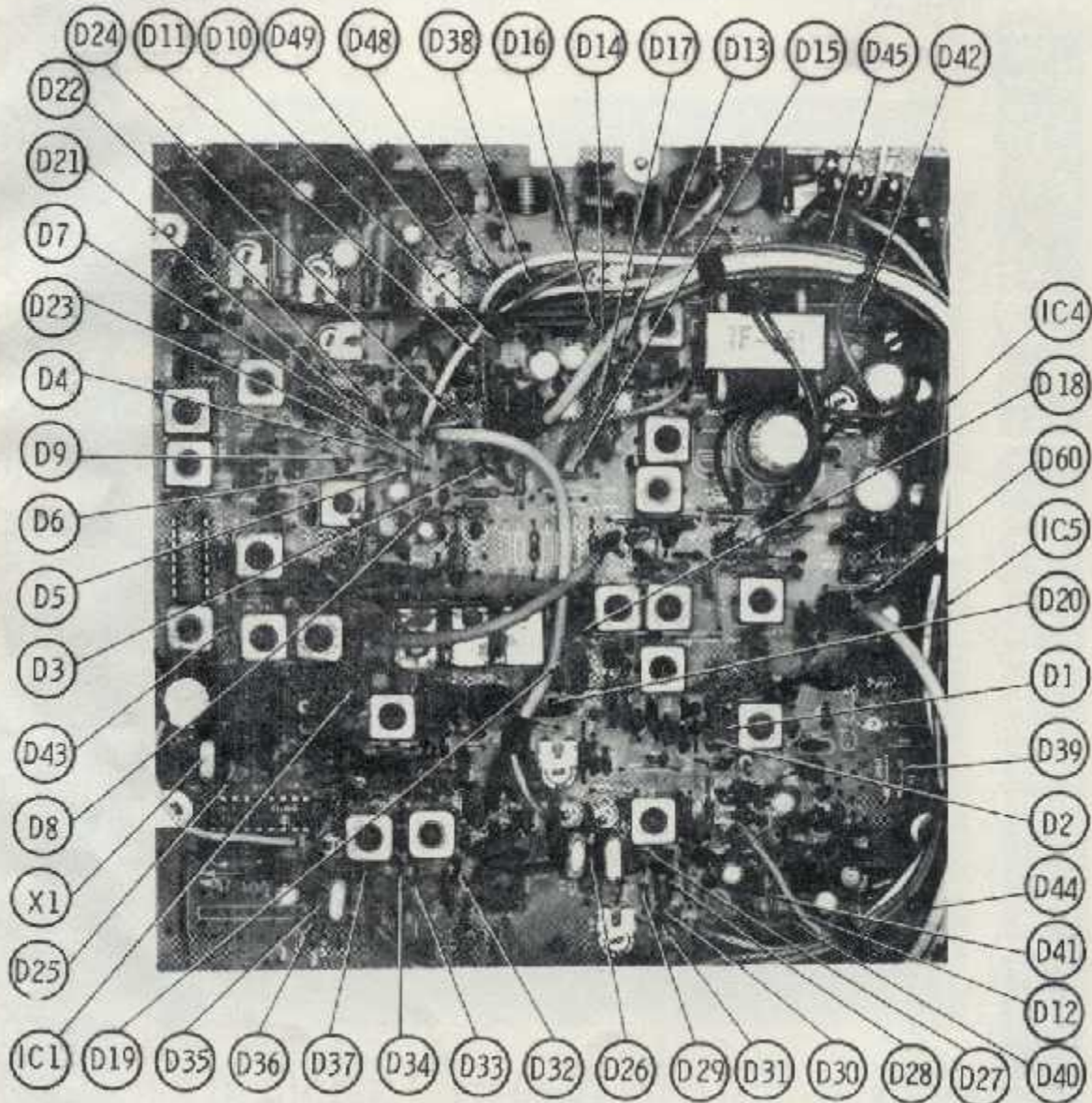

MAIN - BOARD

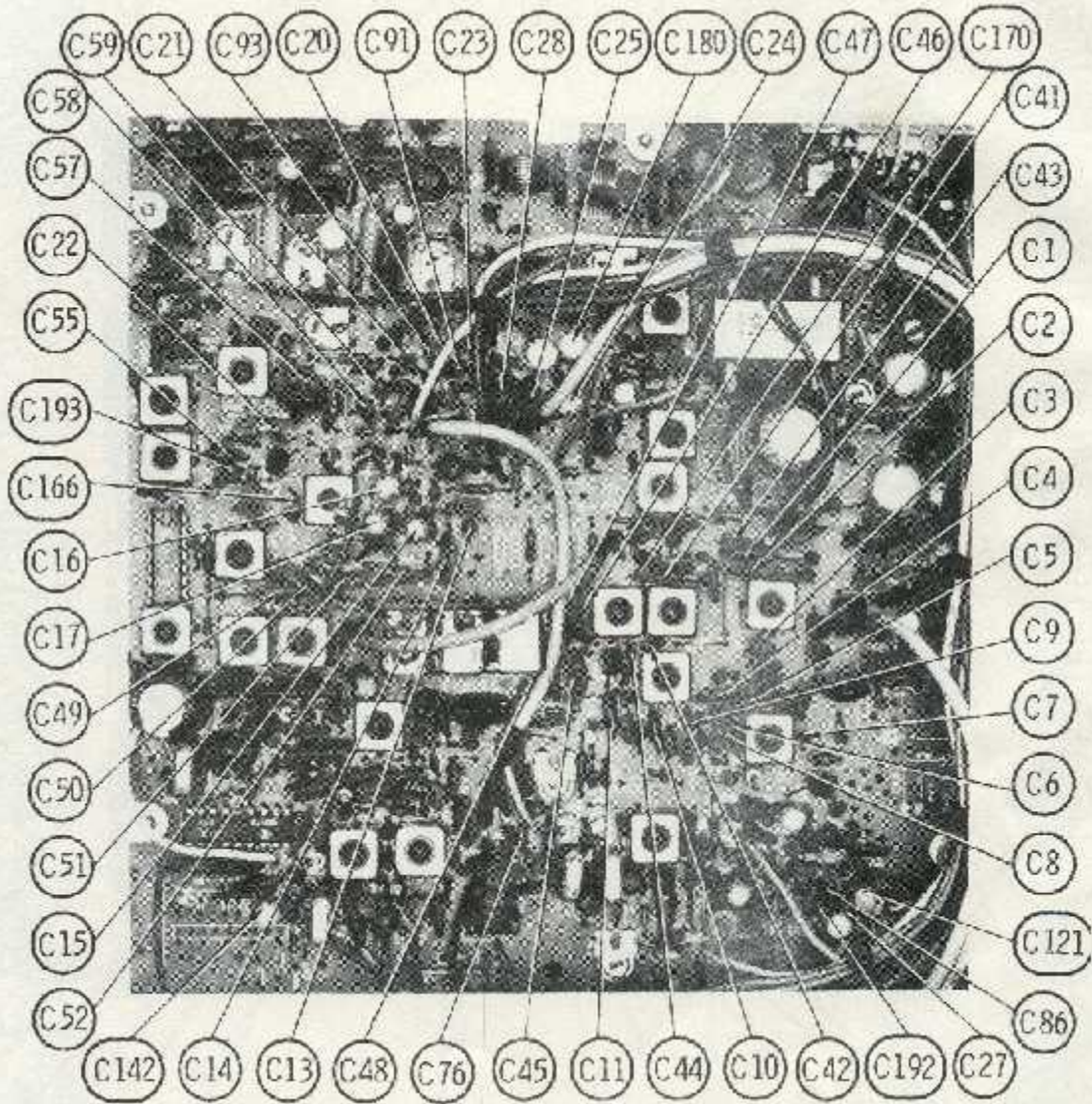

MAIN - BOARD

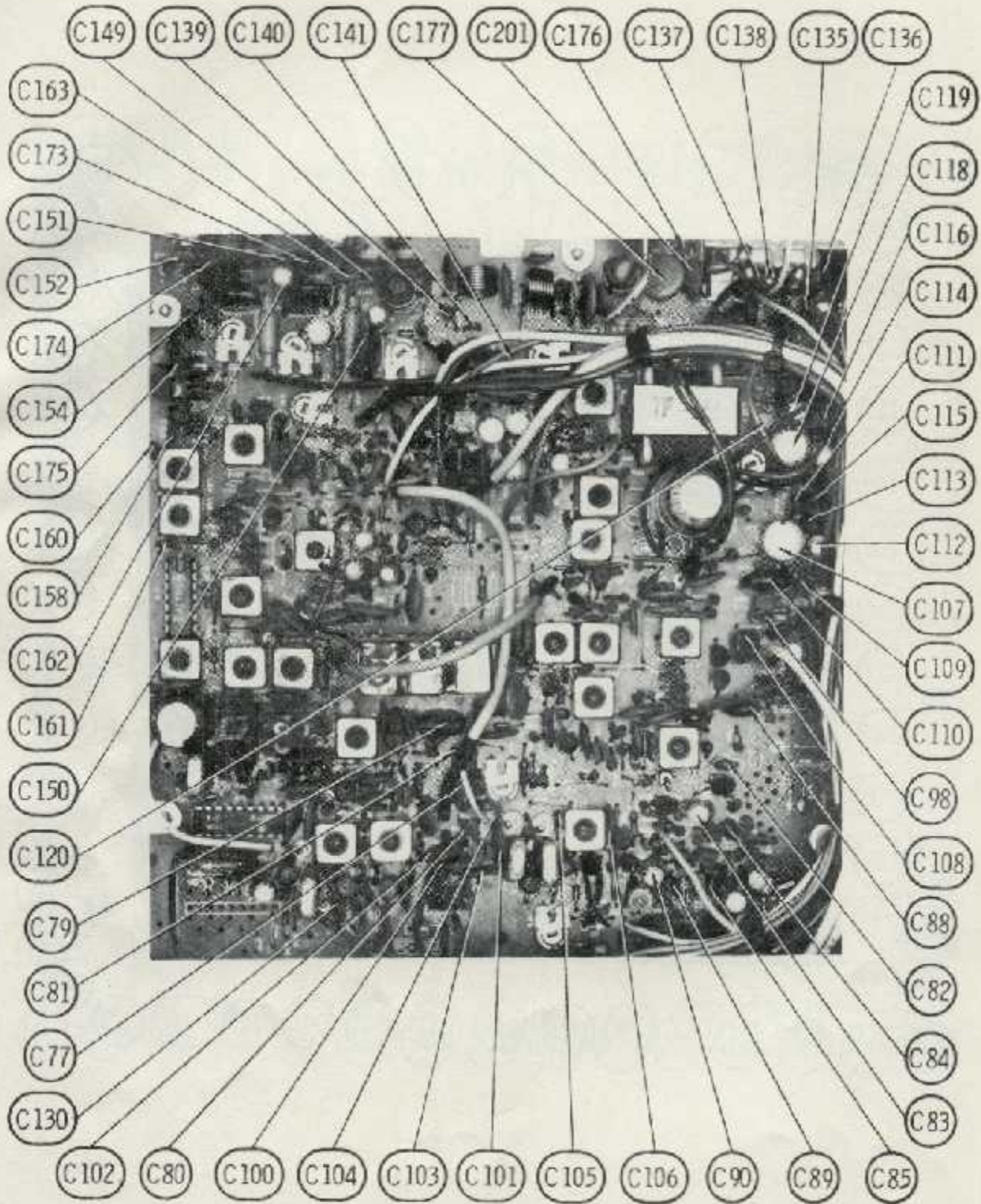

MAIN - BOARD

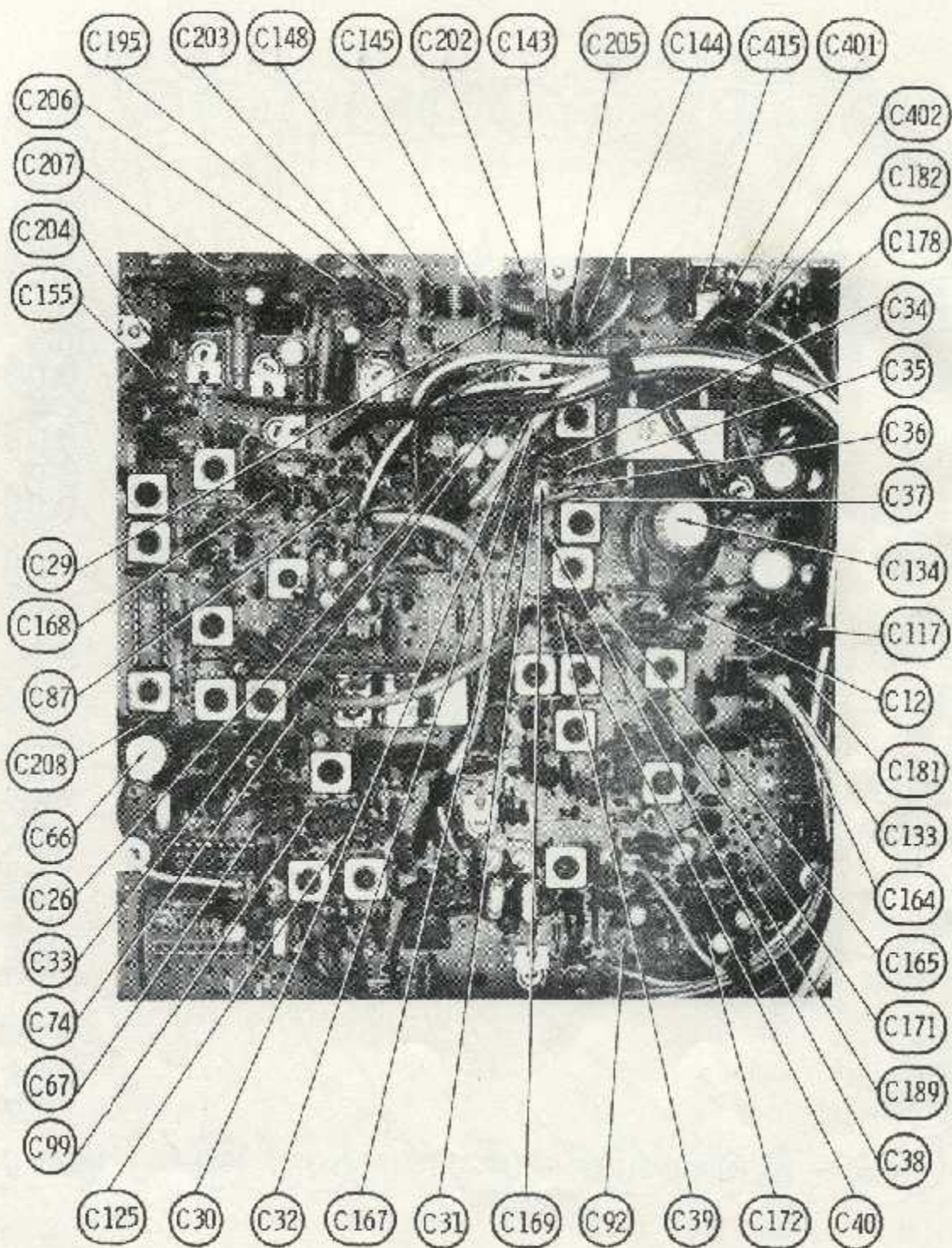

MAIN - BOARD

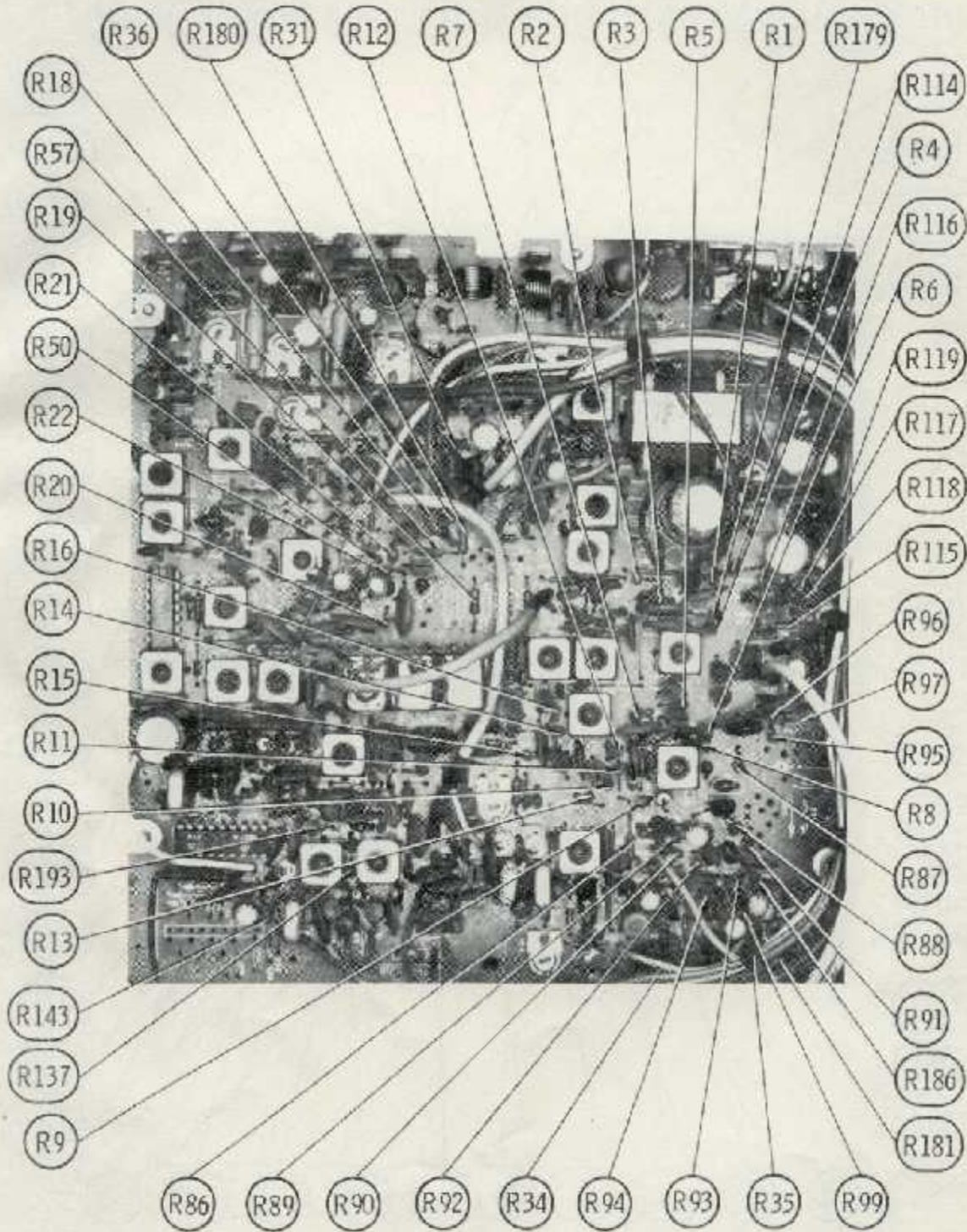

MAIN - BOARD

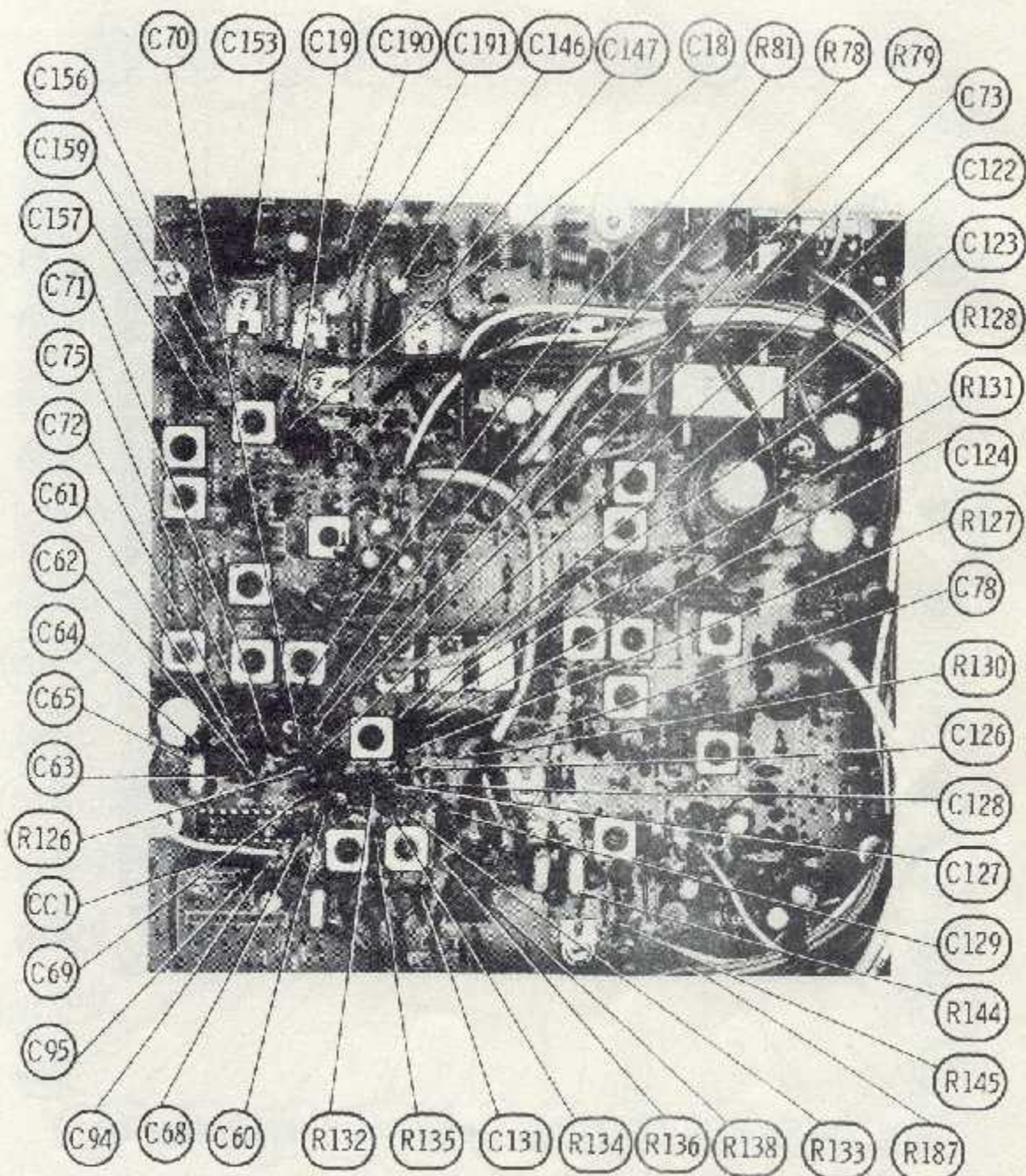

MAIN - BOARD

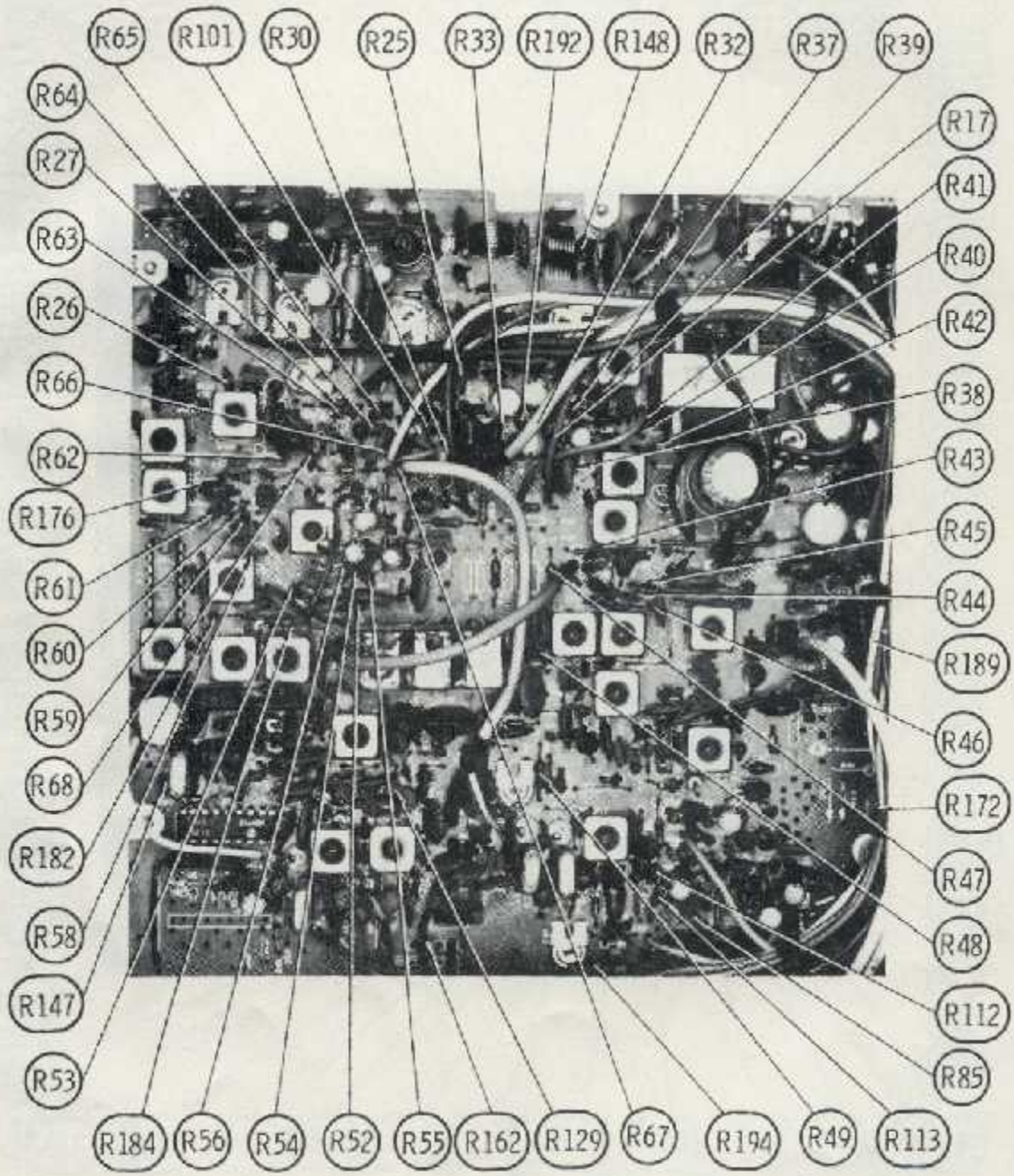

MAIN - BOARD

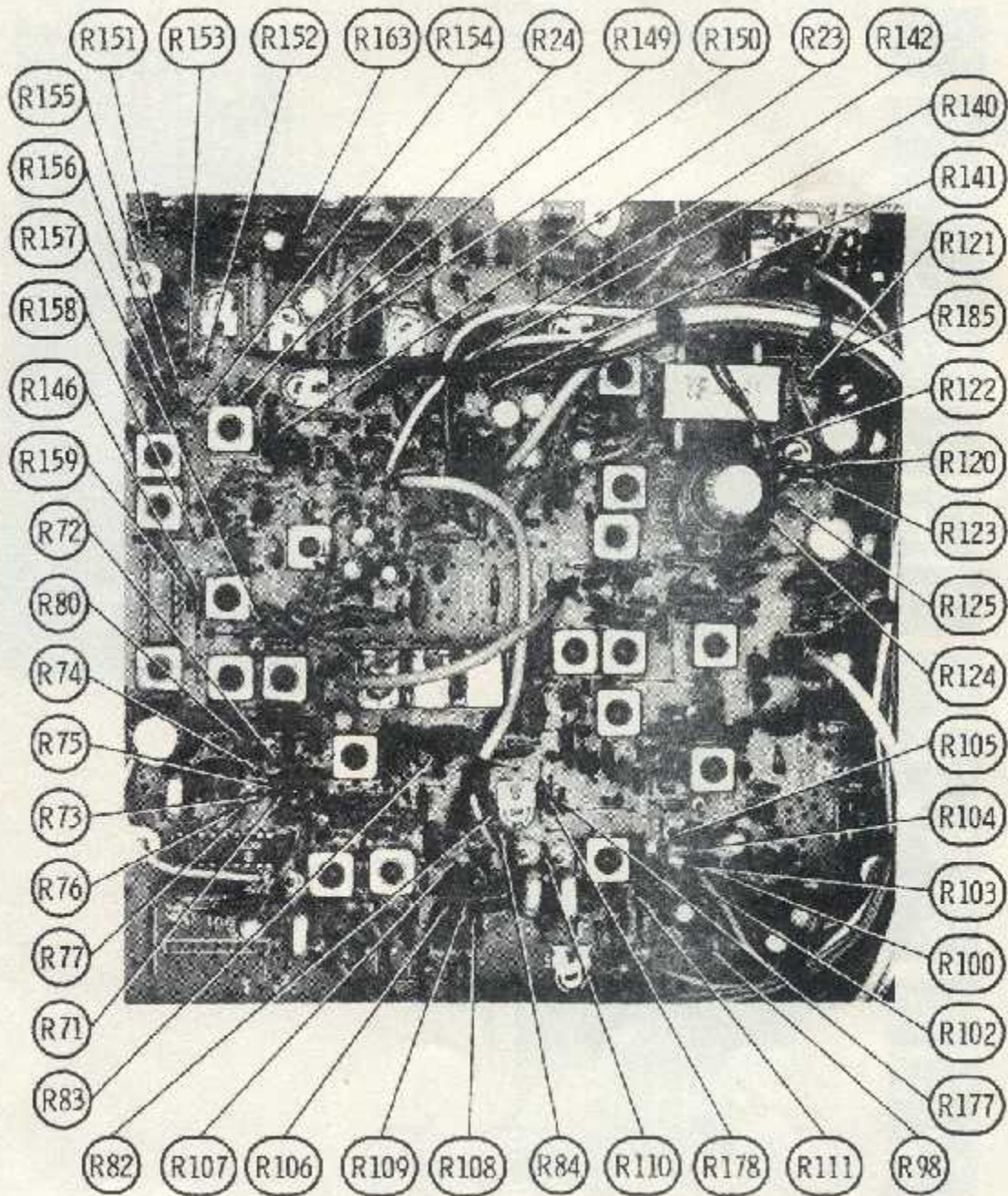

MAIN - BOARD

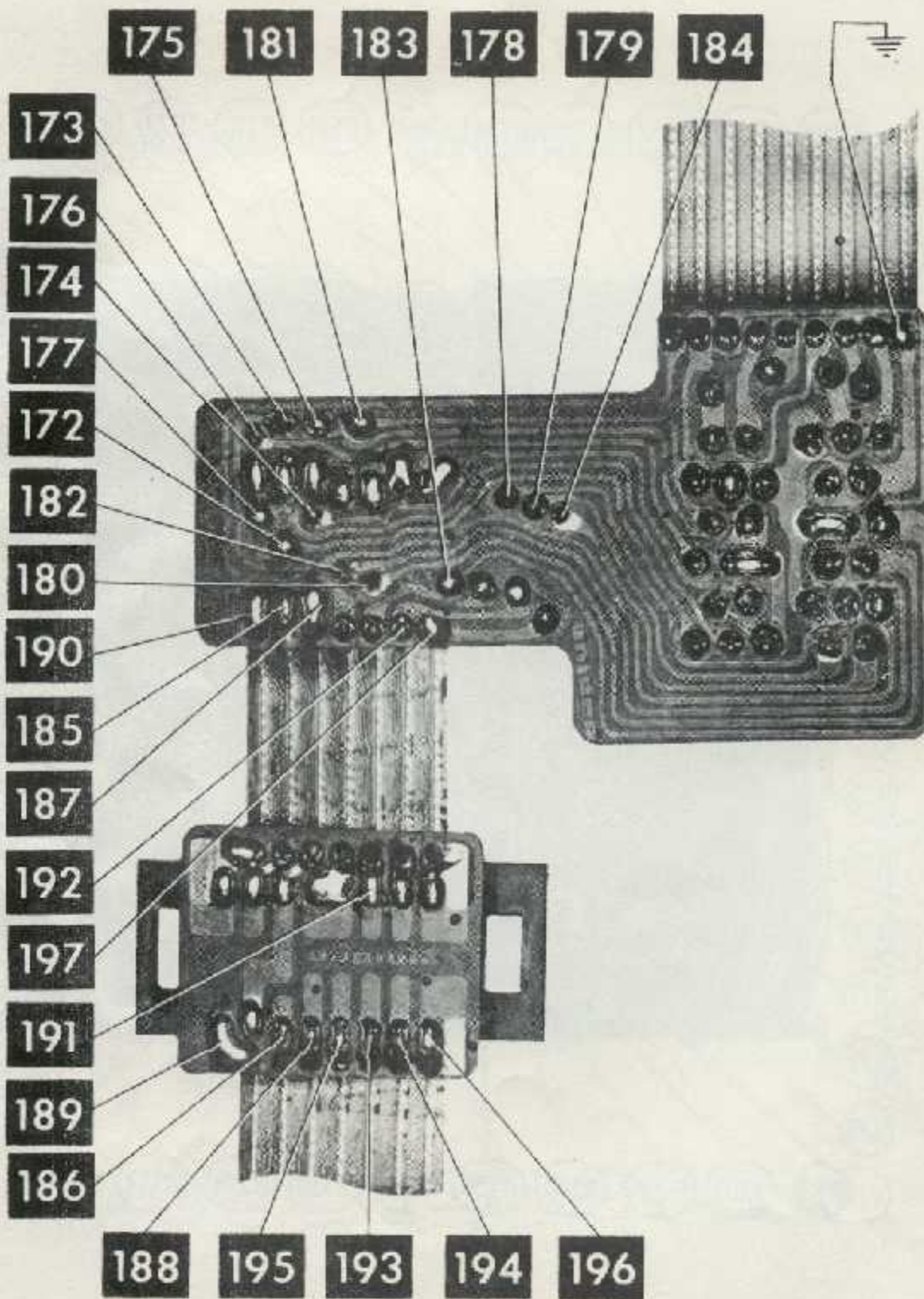

CH. SELECTOR & READOUT BOARD

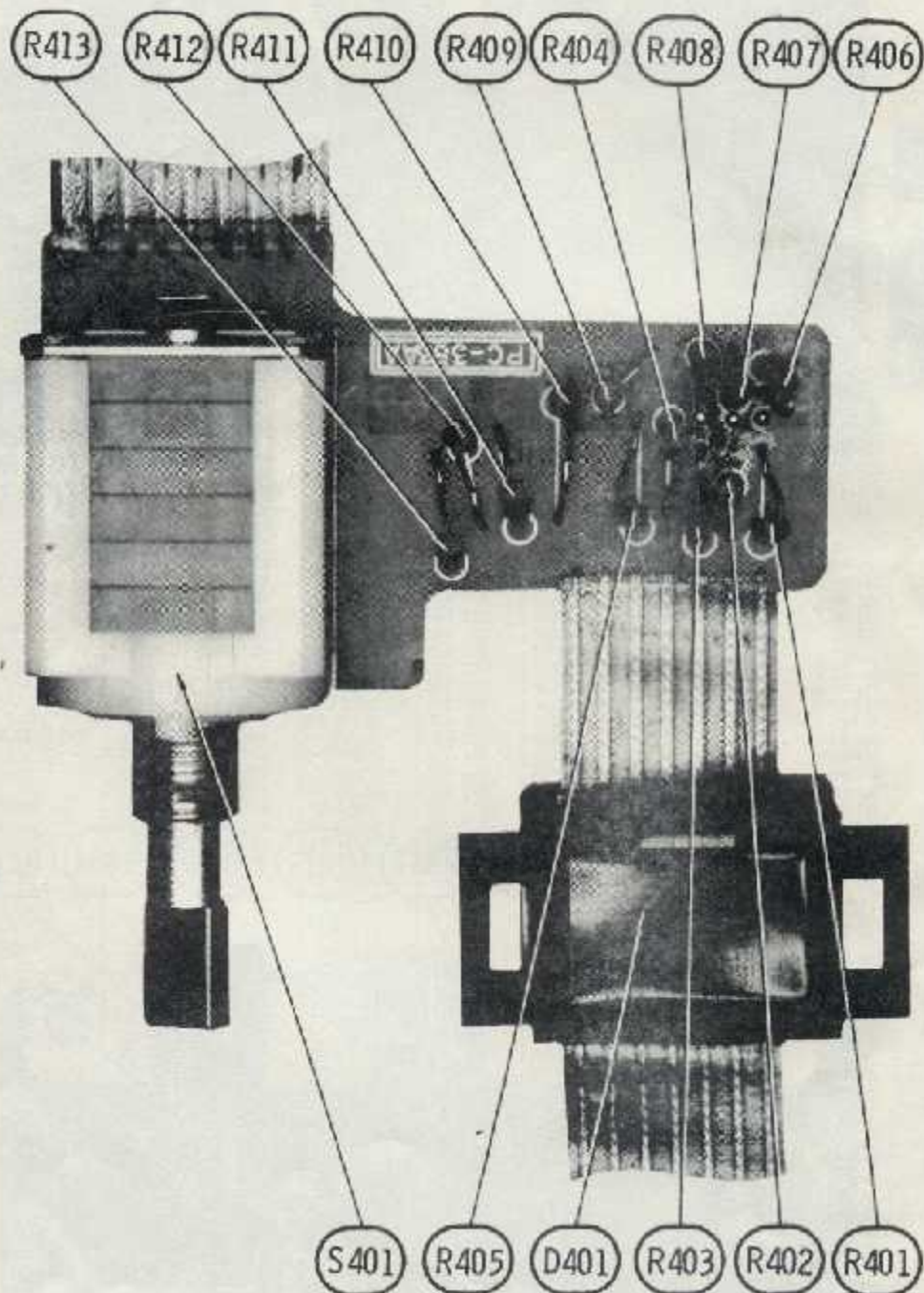

CH. SELECTOR & READOUT BOARD

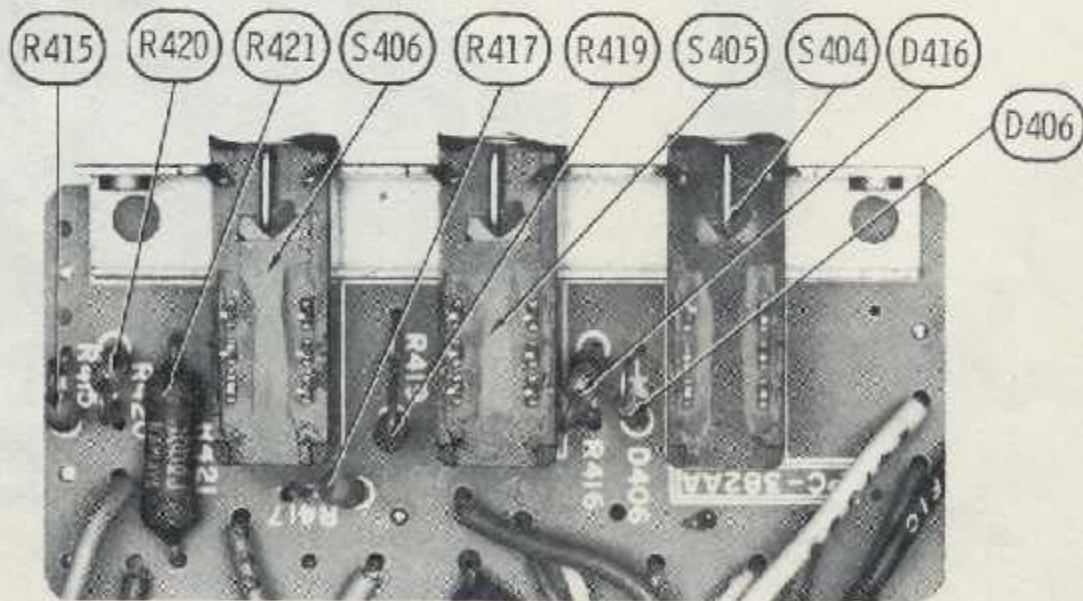
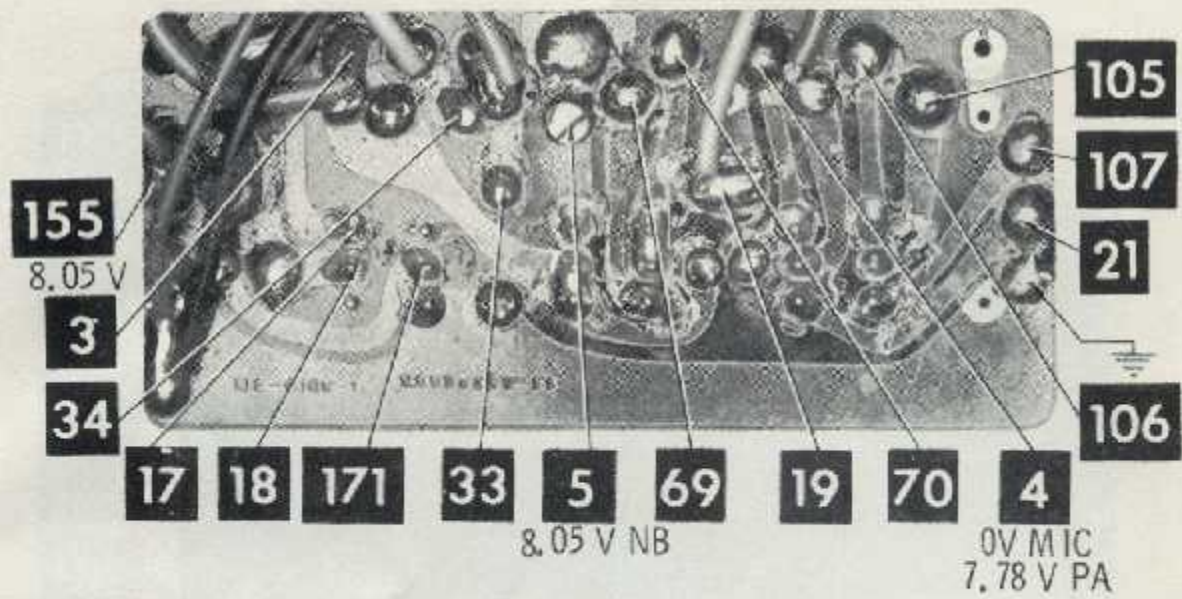

SWITCH BOARD

WIRING DATA

General-use hook-up wire (available in 5 colors)	BELDEN No. 8523	Coiled Microphone Cable	
Shielded hook-up wire (spiral wrapped)	BELDEN No. 8421	3-conductor (1 shielded)	23AWG BELDEN No. 9471 (5')
(braided)	BELDEN No. 8401		BELDEN No. 9497 (5')
Speaker Cable (available in 4 colors)	BELDEN No. 8792		BELDEN No. 9472 (7-1/2')
Bonding Strap	BELDEN No. 8672		26AWG BELDEN No. 9466 (5')
AC Power Cord	(6') BELDEN No. 17105		31AWG BELDEN No. 9468 (10')
	(9') BELDEN No. 17109	4-conductor (unshielded)	23AWG BELDEN No. 9415 (5')
		5-conductor (1 shielded)	26AWG BELDEN No. 9457 (5')
			BELDEN No. 9465 (7-1/2')

SEMICONDUCTORS (Select replacement transistor for best results)

ITEM No.	TYPE No.	MFG. PART No.	REPLACEMENT DATA									
			GENERAL ELECTRIC PART No.	MALLOY PART No.	MOTOROLA PART No.	RAYTHEON PART No.	RCA PART No.	SPRAGUE PART No.	SYLVANIA PART No.	THORNDARSON PART No.	WORKMAN PART No.	ZENITH PART No.
01	1N60	2000-316	1N60	PTC206	HEPR9135	REN 109	SK3088	RT-263	EC6109	1N60	MEP134	ZEN-430
02	1N60	2000-316	1N60	PTC206	HEPR9135	REN 109	SK3088	RT-263	EC6109	1N60	MEP134	ZEN-430
03	1S1588 1S2473 1S2472 1S953	2000-332	GE-514	PTC214	HEPR0602	REN 177	SK3100	RT-218	EC6519	1N4148	MEP925	
04	1S1588 1S2473 1S2472 1S953	2000-332	GE-514	PTC214	HEPR0602	REN 177	SK3100	RT-218	EC6519	1N4148	MEP925	
05	1S1588 1S2473 1S2472 1S953	2000-332	GE-514	PTC214	HEPR0602	REN 177	SK3100	RT-218	EC6519	1N4148	MEP925	
06	1S1588 1S2473 1S2472 1S953	2000-332	GE-514	PTC214	HEPR0602	REN 177	SK3100	RT-218	EC6519	1N4148	MEP925	
07	1S1588 1S2473 1S2472 1S953	2000-332	GE-514	PTC214	HEPR0602	REN 177	SK3100	RT-218	EC6519	1N4148	MEP925	
08	1S1588 1S2473 1S2472 1S953	2000-332	GE-514	PTC214	HEPR0602	REN 177	SK3100	RT-218	EC6519	1N4148	MEP925	
09	1N60	2000-316	1N60	PTC206	HEPR9135	REN 109	SK3088	RT-263	EC6109	1N60	MEP134	ZEN-430
010	1S1588 1S2473 1S2472 1S953	2000-332	GE-514	PTC214	HEPR0602	REN 177	SK3100	RT-218	EC6519	1N4148	MEP925	
011	1S1588 1S2473 1S2472 1S953	2000-332	GE-514	PTC214	HEPR0602	REN 177	SK3100	RT-218	EC6519	1N4148	MEP925	
012	1S1588 1S2473 1S2472 1S953	2000-332	GE-514	PTC214	HEPR0602	REN 177	SK3100	RT-218	EC6519	1N4148	MEP925	
013	MC301 1S2186 BA243 BA244	2000-341			HEPR2500	REN 177	SK3100	RT-218	EC6519	1N4148	MEP925	ZEN-450
014	MC301 1S2186 BA243 BA244	2000-341			HEPR2500	REN 177	SK3100	RT-218	EC6519	1N4148	MEP925	ZEN-450
015	1S1588 1S2473 1S2472 1S953	2000-332	GE-514	PTC214	HEPR0602	REN 177	SK3100	RT-218	EC6519	1N4148	MEP925	ZEN-450
016	1S1588 1S2473 1S2472 1S953	2000-332	GE-514	PTC214	HEPR0602	REN 177	SK3100	RT-218	EC6519	1N4148	MEP925	ZEN-450
017	1S1588 1S2473 1S2472 1S953	2000-332	GE-514	PTC214	HEPR0602	REN 177	SK3100	RT-218	EC6519	1N4148	MEP925	ZEN-450
018	1S1588 1S2473 1S2472 1S953	2000-332	GE-514	PTC214	HEPR0602	REN 177	SK3100	RT-218	EC6519	1N4148	MEP925	ZEN-450
019	1S1588 1S2473 1S2472 1S953	2000-332	GE-514	PTC214	HEPR0602	REN 177	SK3100	RT-218	EC6519	1N4148	MEP925	ZEN-450
020	1S1588 1S2473 1S2472 1S953	2000-332	GE-514	PTC214	HEPR0602	REN 177	SK3100	RT-218	EC6519	1N4148	MEP925	ZEN-450
021	1N60	2000-316	1N60	PTC206	HEPR9135	REN 109	SK3088	RT-263	EC6109	1N60	MEP134	ZEN-430
022	1N60	2000-316	1N60	PTC206	HEPR9135	REN 109	SK3088	RT-263	EC6109	1N60	MEP134	ZEN-430
023	1S1588 1S2473 1S2472 1S953	2000-332	GE-514	PTC214	HEPR0602	REN 177	SK3100	RT-218	EC6519	1N4148	MEP925	
024	1S1588 1S2473 1S2472 1S953	2000-332	GE-514	PTC214	HEPR0602	REN 177	SK3100	RT-218	EC6519	1N4148	MEP925	

SEMICONDUCTORS (Select replacement transistor for best results) (cont)

ITEM No.	TYPE No.	MFR PART No.	REPLACEMENT DATA										
			GENERAL ELECTRIC PART No.	MALLORY PART No.	MOTOROLA PART No.	RAYTHEON PART No.	RCA PART No.	SPRAGUE PART No.	SYLVANIA PART No.	THORNTON PART No.	WORKMAN PART No.	ZENITH PART No.	
IC1	640007	2000-059											
IC2	636719	2000-050											
IC3	A4612	2000-051											
IC4	TA7202T	2000-032											
IC5	M75756	2000-033											
IC6	5042F	2000-034											
71	5816751	2000-213	6E-213	PTC132*	HEP50025*	REN 123A*	5K3246	RT-300	ECG229*		MEP556*	ZEN-127	
	581640		6E-61*	PTC136*	HEP50014*	REN 107	5K3122	RT-134	ECG107	25C460	MEP460	121-222	
	581639		6E-61*	PTC136*	HEP50015*	REN 123A*	5K3444	RT-308	ECG123A*	25C839	MEP736*	121-2900*	
	25C 674		6E-61	PTC132*	HEP50015*	REN 107	5K3246	RT-308	ECG229*	25C935	MEP556*		
	25C 730		6E-17*	PTC136*	HEP50025*	REN 107	5K3018*	RT-107A	ECG115*		MEP535	121-303	
	25C1675.L		6E-213	PTC132*	HEP50025*	REN 123A*	5K3246	RT-306	ECG229*		MEP906*	ZEN-127	
	581640		6E-61*	PTC136*	HEP50014*	REN 107	5K3122	RT-134	ECG107	25C460	MEP460	121-222	
72	581639	2000-213	6E-61*	PTC132*	HEP50015*	REN 123A*	5K3444	RT-306	ECG123A*	25C839	MEP736*	121-2900*	
	581674		6E-10*	PTC121*	HEP50015*	REN 199	5K3124	RT-107A	ECG199	25C975	MEP556	ZEN-119	
	25C 730		6E-17*	PTC136*	HEP50025*	REN 107	5K3018*	RT-107A	ECG115*		MEP535	121-303	
	25C1730.L		6E-17*	PTC136*	HEP50025*	REN 107	5K3018*	RT-107A	ECG115*		MEP535	121-303	
	25C 675		6E-213	PTC132*	HEP50025*	REN 123A*	5K3246	RT-306	ECG229*		MEP906*	ZEN-127	
	25C1674		6E-61	PTC132*	HEP50010*	REN 107	5K3246	RT-306	ECG229*	25C535	MEP460	121-222	
	25C460		6E-61*	PTC136*	HEP50014*	REN 107	5K3122	RT-134	ECG107	25C460	MEP460	121-222	
73	581639	2000-214	6E-61*	PTC132*	HEP50015*	REN 123A*	5K3444	RT-306	ECG123A*	25C839	MEP736*	121-2900*	
	25C1730.L		6E-17*	PTC136*	HEP50025*	REN 107	5K3018*	RT-107A	ECG115*		MEP535	121-303	
	25C 675		6E-213	PTC132*	HEP50025*	REN 123A*	5K3246	RT-306	ECG229*		MEP906*	ZEN-127	
	25C1674		6E-61	PTC132*	HEP50010*	REN 107	5K3246	RT-306	ECG229*	25C535	MEP460	121-222	
	25C460		6E-61*	PTC136*	HEP50014*	REN 107	5K3122	RT-134	ECG107	25C460	MEP460	121-222	
	581639		6E-61*	PTC132*	HEP50015*	REN 123A*	5K3444	RT-306	ECG123A*	25C839	MEP736*	121-2900*	
	74		25C9460	2000-235	6E-212	PTC121*	HEP50015*	REN 199	5K3124	RT-107A	ECG199	25C945	MEP1945
25C945A		6E-212	PTC121*		HEP50015*	REN 199	5K3124	RT-107A	ECG199	25C945	MEP1945	121-2900*	
25C458		6E-210*	PTC121*		HEP50009*	REN 123A*	5K3122	RT-187	ECG289	25C458	MEP458	121-2900*	
25C372		6E-61*	PTC121*		HEP50015*	REN 123A*	5K3444	RT-306	ECG123A*	25C372	MEP372	121-2900*	
25C900		6E-62	PTC139*		HEP50015*	REN 199	5K3124	RT-302	ECG199	25C900	MEP66	ZEN-119	
25C828		6E-61*	PTC139*		HEP50015*	REN 199	5K3444	RT-302	ECG199	25C828	MEP828	ZEN-119	
25C1740		6E-62	PTC121*		HEP50015*	REN 123A*	5K3122	RT-109*	ECG123A*		MEP736*	121-2972	
75	25C945A	2000-235	6E-212	PTC121*	HEP50015*	REN 199	5K3124	RT-107A	ECG199	25C945	MEP1945	121-2900*	
	25C458		6E-210*	PTC121*	HEP50009*	REN 123A*	5K3122	RT-187	ECG289	25C458	MEP458	121-2900*	
	25C372		6E-61*	PTC121*	HEP50015*	REN 123A*	5K3444	RT-306	ECG123A*	25C372	MEP372	121-2900*	
	25C900		6E-62	PTC139*	HEP50015*	REN 199	5K3124	RT-302	ECG199	25C900	MEP66	ZEN-119	
	25C828		6E-61*	PTC139*	HEP50015*	REN 199	5K3444	RT-302	ECG199	25C828	MEP828	ZEN-119	
	25C1740		6E-62	PTC121*	HEP50015*	REN 123A*	5K3122	RT-109*	ECG123A*		MEP736*	121-2972	
	25C945A		6E-212	PTC121*	HEP50015*	REN 199	5K3124	RT-107A	ECG199	25C945	MEP1945	121-2900*	
76	25C458	2000-213	6E-61*	PTC121*	HEP50009*	REN 123A*	5K3122	RT-187	ECG289	25C458	MEP458	121-2900*	
	25C372		6E-61*	PTC121*	HEP50015*	REN 123A*	5K3444	RT-306	ECG123A*	25C372	MEP372	121-2900*	
	25C900		6E-62	PTC139*	HEP50015*	REN 199	5K3124	RT-302	ECG199	25C900	MEP66	ZEN-119	
	25C828		6E-61*	PTC139*	HEP50015*	REN 199	5K3444	RT-302	ECG199	25C828	MEP828	ZEN-119	
	25C1740		6E-62	PTC121*	HEP50015*	REN 123A*	5K3122	RT-109*	ECG123A*		MEP736*	121-2972	
	25C460		6E-61*	PTC136*	HEP50014*	REN 107	5K3122	RT-134	ECG107	25C460	MEP460	121-222	
	25C839		6E-61*	PTC132*	HEP50015*	REN 123A*	5K3444	RT-306	ECG123A*	25C839	MEP736*	121-2900*	
77	25C 674	2000-214	6E-61	PTC132*	HEP50015*	REN 107	5K3246	RT-306	ECG229*	25C935	MEP556*		
	25C 730		6E-17*	PTC136*	HEP50025*	REN 107	5K3018*	RT-107A	ECG115*		MEP535	121-303	
	25A753		6E-48	PTC144*	HEP50015*	REN 123A*	5K3122	RT-107A	ECG115*		MEP60*	121-888	
	25A955		6E-221*	PTC103*	HEP50013*	REN 159*	5K3456	RT-303	ECG159*	25A955	MEP955	ZEN-106	
	25A564		6E-65	PTC103*	HEP50019*	REN 234	5K3114	RT-303	ECG234	25A564	MEP564	ZEN-879	
	25C945A		6E-212	PTC121*	HEP50015*	REN 199	5K3124	RT-107A	ECG199	25C945	MEP1945	121-2900*	
	25C458		6E-210*	PTC121*	HEP50009*	REN 123A*	5K3122	RT-187	ECG289	25C458	MEP458	121-2900*	
78	25C372	2000-235	6E-61*	PTC121*	HEP50015*	REN 123A*	5K3444	RT-306	ECG123A*	25C372	MEP372	121-2900*	
	25C900		6E-62	PTC139*	HEP50015*	REN 199	5K3124	RT-302	ECG199	25C900	MEP66	ZEN-119	
	25C828		6E-61	PTC139*	HEP50015*	REN 199	5K3444	RT-302	ECG199	25C828	MEP828	ZEN-119	
	25C620		6E-35	PTC118	HEP50020	REN 162	5K3115	RT-139	ECG162		MEP707		
	25C1740		6E-62	PTC121*	HEP50015*	REN 123A*	5K3122	RT-109*	ECG123A*		MEP736*	121-2972	
	25C1874.L		6E-61	PTC132*	HEP50010*	REN 107	5K3246	RT-308	ECG229*	25C935	MEP556*		
	25C1730		6E-17*	PTC136*	HEP50025*	REN 107	5K3018*	RT-107A	ECG115*		MEP535	121-303	
79	25C1858	2000-240	6E-17*	PTC136*	HEP50025*	REN 107	5K3018*	RT-107A	ECG115*		MEP535	121-303	
	25C710		6E-213*	PTC132*	HEP50016*	REN 123A*	5K3444	RT-309*	ECG123A*	25C710	MEP710	121-2900*	
	25C1675.L		6E-213*	PTC132*	HEP50025*	REN 123A*	5K3246	RT-309*	ECG229*		MEP956*	ZEN-127	
	25C460		6E-214	PTC132*	HEP50020*	REN 161	5K3039*	RT-134	ECG107	25C717*	MEP66	ZEN-104	
	25C839		6E-61*	PTC132*	HEP50015*	REN 123A*	5K3444	RT-308	ECG123A*	25C839	MEP736*	121-2900*	
	25C1674		6E-6*	PTC132*	HEP50010*	REN 107	5K3246	RT-308	ECG229*	25C535	MEP460	121-222	
	25C1730		6E-17*	PTC136*	HEP50025*	REN 107	5K3018*	RT-107A	ECG115*		MEP535	121-303	
710	25C945A	2000-235	6E-212	PTC121*	HEP50015*	REN 199	5K3124	RT-107A	ECG199	25C945	MEP1945	121-2900*	
	25C458		6E-210*	PTC121*	HEP50009*	REN 123A*	5K3122	RT-187	ECG289	25C458	MEP458	121-2900*	
	25C372		6E-61*	PTC121*	HEP50015*	REN 123A*	5K3444	RT-306	ECG123A*	25C372	MEP372	121-2900*	
	25C900		6E-62	PTC139*	HEP50015*	REN 199	5K3124	RT-302	ECG199	25C900	MEP66	ZEN-119	
	25C828		6E-61	PTC139*	HEP50015*	REN 199	5K3444	RT-302	ECG199	25C828	MEP828	ZEN-119	
	25C620		6E-35	PTC118	HEP50020	REN 162	5K3115	RT-139	ECG162		MEP707		
	25C1740		6E-62	PTC121*	HEP50015*	REN 123A*	5K3122	RT-109*	ECG123A*		MEP736*	121-2972	
711	25C945A	2000-235	6E-212	PTC121*	HEP50015*	REN 199	5K3124	RT-107A	ECG199	25C945	MEP1945	121-2900*	
	25C458		6E-210*	PTC121*	HEP50009*	REN 123A*	5K3122	RT-187	ECG289	25C458	MEP458	121-2900*	
	25C372		6E-61*	PTC121*	HEP50015*	REN 123A*	5K3444	RT-306	ECG123A*	25C372	MEP372	121-2900*	
	25C900		6E-62	PTC139*	HEP50015*	REN 199	5K3124	RT-302	ECG199	25C900	MEP66	ZEN-119	
	25C828		6E-61	PTC139*	HEP50015*	REN 199	5K3444	RT-302	ECG199	25C828	MEP828	ZEN-119	
	25C620		6E-35	PTC118	HEP50020	REN 162	5K3115	RT-139	ECG162		MEP707		
	25C1740		6E-62	PTC121*	HEP50015*	REN 123A*	5K3122	RT-109*	ECG123A*		MEP736*	121-2972	
712	25C945A	2000-213	6E-212	PTC121*	HEP50015*	REN 199	5K3124	RT-107A	ECG199	25C945	MEP1945	121-2900*	
	25C458		6E-210*	PTC121*	HEP50009*	REN 123A*	5K3122	RT-187	ECG289	25C458	MEP458	121-2900*	
	25C372		6E-61*	PTC121*	HEP50015*	REN 123A*	5K3444	RT-306	ECG123A*	25C372	MEP372	121-2900*	
	25C900		6E-62	PTC139*	HEP50015*	REN 199	5K3124	RT-302	ECG199	25C900	MEP66	ZEN-119	
	25C828		6E-61	PTC139*	HEP50015*	REN 199	5K3444	RT-302	ECG199	25C828	MEP828	ZEN-119	
	25C620		6E-35	PTC118	HEP50020	REN 162	5K3115	RT-139	ECG162		MEP707		
	25C1740		6E-62	PTC121*	HEP50015*	REN 123A*	5K3122	RT-109*	ECG123A*		MEP736*	121-2972	
713	25C945A	2000-235	6E-212	PTC121*	HEP50015*	REN 199	5K3124	RT-107A					

SEMICONDUCTORS (Select replacement transistor for best results) (cont)

ITEM No.	TYPE No.	MFG. PART No.	REPLACEMENT DATA									
			GENERAL ELECTRIC PART No.	MALLORY PART No.	MOTOROLA PART No.	RAYTHEON PART No.	RCA PART No.	SPRAGUE PART No.	SYLVANIA PART No.	THORDARSON PART No.	WORKMAN PART No.	ZENITH PART No.
TR16	25C1730, L	2000-214	GE-17*	PTC135*	HEP50025*	REN 107	SK3018*	RT-107A	ECG316*		WEP535	121-888
	25C1675		GE-213	PTC132*	HEP50025*	REN 123A*	SK3246	RT-308	ECG229*		WEP956*	ZEN-127
	25C1674		GE-61	PTC132*	HEP50010*	REN 107	SK3246	RT-308	ECG229*	25C835	WEP956*	
	25C839		GE-61*	PTC135*	HEP50014*	REN 107	SK3122	RT-134	ECG107	25C460	WEP460	121-722
TR17	25C1675, L	2000-213	GE-61*	PTC132*	HEP50015*	REN 123A*	SK3444	RT-308	ECG123A*	25C839	WEP736*	121-29000*
	25C839		GE-213	PTC132*	HEP50025*	REN 123A*	SK3246	RT-308	ECG229*		WEP956*	ZEN-127
	25C839		GE-61*	PTC135*	HEP50014*	REN 107	SK3122	RT-134	ECG107	25C460	WEP460	121-722
	25C1674		GE-61*	PTC132*	HEP50015*	REN 123A*	SK3444	RT-308	ECG123A*	25C839	WEP736*	121-29000*
TR18	25C1675, L	2000-240	GE-61	PTC132*	HEP50010*	REN 107	SK3246	RT-308	ECG229*	25C535	WEP535	121-888
	25C1342		GE-61*	PTC132*	HEP50014*	REN 229*	SK3018*	RT-109A*	ECG229*		WEP956*	ZEN-127
	25C1675		GE-213	PTC132*	HEP50025*	REN 123A*	SK3246	RT-308	ECG229*		WEP956*	ZEN-127
	25C839		GE-60*	PTC132*	HEP50016*	REN 229	SK3018	RT-308	ECG229*	25C930	WEP956*	ZEN-127
TR19	25C1675	2000-213	GE-213	PTC122*	HEP50025*	REN 123A*	SK3246	RT-308	ECG229*		WEP956*	ZEN-127
	25C839		GE-61*	PTC135*	HEP50014*	REN 107	SK3122	RT-134	ECG107	25C460	WEP460	121-722
	25C1674		GE-61*	PTC132*	HEP50015*	REN 123A*	SK3444	RT-308	ECG123A*	25C839	WEP736*	121-29000*
	25C1730		GE-61	PTC132*	HEP50010*	REN 107	SK3246	RT-308	ECG229*	25C535	WEP956*	
TR20	25C945A0	2000-235	GE-17*	PTC136*	HEP50025*	REN 107	SK3018*	RT-107A	ECG316*		WEP535	121-888
	25C839		GE-212	PTC121*	HEP50015*	REN 199	SK3124	RT-107A	ECG199	25C945	WEP1945	121-29000
	25C1674		GE-210*	PTC121*	HEP50009*	REN 123A*	SK3122	RT-187	ECG289	25C945	WEP1945	121-29000*
	25C372		GE-61*	PTC121*	HEP50015*	REN 123A*	SK3444	RT-308	ECG123A*	25C372	WEP372	121-29000*
TR21	25C1675, L	2000-213	GE-62	PTC139*	HEP50015*	REN 199	SK3124	RT-302	ECG199	25C900	WEP66	ZEN-119
	25C1740		GE-62	PTC121*	HEP50015*	REN 123A*	SK3122	RT-187	ECG289	25C828	WEP828	ZEN-119
	25C1675, L		GE-213	PTC132*	HEP50025*	REN 123A*	SK3246	RT-308	ECG229*	25C460	WEP460	121-722
	25C839		GE-61*	PTC135*	HEP50015*	REN 107	SK3444	RT-308	ECG123A*	25C839	WEP736*	121-29000*
TR22	25C1675, L	2000-213	GE-17*	PTC135*	HEP50025*	REN 107	SK3018*	RT-107A	ECG316*		WEP535	121-888
	25C839		GE-61*	PTC132*	HEP50015*	REN 123A*	SK3444	RT-308	ECG229*		WEP956*	ZEN-127
	25C1674		GE-210*	PTC121*	HEP50009*	REN 199	SK3124	RT-107A	ECG199	25C945	WEP1945	121-29000*
	25C1730		GE-17*	PTC136*	HEP50025*	REN 107	SK3018*	RT-107A	ECG316*		WEP535	121-888
TR23	25C1675, L	2000-213	GE-213	PTC132*	HEP50025*	REN 123A*	SK3246	RT-308	ECG229*	25C839	WEP736*	121-29000*
	25C460		GE-61*	PTC135*	HEP50014*	REN 107	SK3122	RT-134	ECG107	25C460	WEP460	121-722
	25C839		GE-61*	PTC132*	HEP50015*	REN 123A*	SK3444	RT-308	ECG123A*	25C839	WEP736*	121-29000*
	25C1674		GE-61	PTC132*	HEP50010*	REN 107	SK3246	RT-308	ECG229*	25C535	WEP956*	
TR24	25C1675, L	2000-213	GE-17*	PTC135*	HEP50025*	REN 107	SK3018*	RT-107A	ECG316*		WEP535	121-888
	25C460		GE-213	PTC132*	HEP50025*	REN 123A*	SK3246	RT-308	ECG229*	25C460	WEP460	121-722
	25C839		GE-61*	PTC135*	HEP50014*	REN 107	SK3444	RT-308	ECG123A*	25C839	WEP736*	121-29000*
	25C1674		GE-61	PTC132*	HEP50010*	REN 107	SK3246	RT-308	ECG229*	25C535	WEP956*	
TR25	25C1675, L	2000-213	GE-17*	PTC135*	HEP50025*	REN 107	SK3018*	RT-107A	ECG316*		WEP535	121-888
	25C460		GE-213	PTC132*	HEP50025*	REN 123A*	SK3246	RT-308	ECG229*		WEP956*	ZEN-127
	25C839		GE-61*	PTC135*	HEP50014*	REN 107	SK3122	RT-134	ECG107	25C460	WEP460	121-722
	25C1674		GE-61*	PTC132*	HEP50015*	REN 123A*	SK3444	RT-308	ECG123A*	25C839	WEP736*	121-29000*
TR26	25C496-0	2000-241	GE-17*	PTC135*	HEP50025*	REN 107	SK3018*	RT-107A	ECG316*		WEP535	121-888
	25C1845		GE-336	PTC904	HEP53001*	REN 295	SK3253	RT-114*	ECG289	25C495	WEP880	800-767
	25D471		GE-268	PTC144*		REN 288	SK3124		ECG289	25C495	WEP910	121-1014
	25C2238		GE-336	PTC904		REN 295	SK3253		ECG289	25C495	WEP910	800-767
TR27	25C945A0	2000-235	GE-212	PTC121*	HEP50015*	REN 199	SK3124	RT-107A	ECG199	25C945	WEP1945	121-29000
	25C839		GE-212	PTC121*	HEP50015*	REN 199	SK3124	RT-107A	ECG199	25C945	WEP1945	121-29000
	25C458		GE-210*	PTC121*	HEP50009*	REN 123A*	SK3122	RT-187	ECG289	25C458	WEP458	121-29000*
	25C372		GE-61*	PTC121*	HEP50015*	REN 123A*	SK3444	RT-308	ECG123A*	25C372	WEP372	121-29000*
TR28	25C945A0	2000-235	GE-62	PTC139*	HEP50015*	REN 199	SK3124	RT-302	ECG199	25C900	WEP66	ZEN-119
	25C1740		GE-61*	PTC135*	HEP50015*	REN 199	SK3444	RT-302	ECG199	25C828	WEP828	ZEN-119
	25C945A0		GE-62	PTC121*	HEP50015*	REN 123A*	SK3122	RT-109*	ECG123A*		WEP736*	121-972
	25C945A		GE-212	PTC121*	HEP50015*	REN 199	SK3124	RT-107A	ECG199	25C945	WEP1945	121-29000
TR29	25C945A0	2000-235	GE-210*	PTC121*	HEP50009*	REN 123A*	SK3122	RT-187	ECG289	25C458	WEP458	121-29000*
	25C372		GE-61*	PTC121*	HEP50015*	REN 123A*	SK3444	RT-308	ECG123A*	25C372	WEP372	121-29000*
	25C900		GE-62	PTC139*	HEP50015*	REN 199	SK3124	RT-302	ECG199	25C900	WEP66	ZEN-119
	25C828		GE-61*	PTC135*	HEP50015*	REN 199	SK3444	RT-302	ECG199	25C828	WEP828	ZEN-119
TR30	25A733	2000-218	GE-62	PTC121*	HEP50015*	REN 123A*	SK3122	RT-109*	ECG123A*		WEP736*	121-972
	25A495		GE-212	PTC121*	HEP50015*	REN 199	SK3124	RT-107A	ECG199	25C945	WEP1945	121-29000
	25A564		GE-210*	PTC121*	HEP50009*	REN 123A*	SK3122	RT-187	ECG289	25C458	WEP458	121-29000*
	25C372		GE-61*	PTC121*	HEP50015*	REN 123A*	SK3444	RT-308	ECG123A*	25C372	WEP372	121-29000*
TR31	25A733	2000-218	GE-65	PTC103*	HEP50019*	REN 234	SK3114	RT-303	ECG234	25A564	WEP564	121-879
	25A495		GE-48	PTC144*	HEP50012*	REN 259*	SK3114	RT-115*	ECG129*		WEP60*	
	25A564		GE-221*	PTC103*	HEP50019*	REN 156*	SK3466	RT-303	ECG159*	25A495	WEP495	ZEN-106
	25C372		GE-65	PTC103*	HEP50019*	REN 234	SK3114	RT-303	ECG234	25A564	WEP564	121-879
TR32	25C945A0	2000-235	GE-62	PTC139*	HEP50015*	REN 199	SK3124	RT-302	ECG199	25C900	WEP66	ZEN-119
	25C945A		GE-212	PTC121*	HEP50015*	REN 199	SK3124	RT-107A	ECG199	25C945	WEP1945	121-29000
	25C458		GE-210*	PTC121*	HEP50009*	REN 123A*	SK3122	RT-187	ECG289	25C458	WEP458	121-29000*
	25C372		GE-61*	PTC121*	HEP50015*	REN 123A*	SK3444	RT-308	ECG123A*	25C372	WEP372	121-29000*

SEMICONDUCTORS (Select replacement transistor for best results) (cont)

ITEM No.	TYPE No.	MFG. PART No.	REPLACEMENT DATA									
			GENERAL ELECTRIC PART No.	MALLORY PART No.	MOTOROLA PART No.	RAYTHEON PART No.	RCA PART No.	SPRAGUE PART No.	SYLVANIA PART No.	THORNDARSON PART No.	WCRKMAN PART No.	ZENITH PART No.
TR33	25C9450Q	2000-235	GE-212	PTC121*	HEP50015*	REN 199	SK3122	RT-107A	ECG199	25C945	WEP1945	121-2900
	25C945A		GE-212	PTC121*	HEP50015*	REN 199	SK3122	RT-107A	ECG199	25C945	WEP1945	121-2900
	25L484		GE-210*	PTC121*	HEP50009*	REN 123A*	SK3122	RT-167	ECG289	25C458	WEP458	121-2900*
	25L372		GE-61*	PTC121*	HEP50015*	REN 123A*	SK3444	RT-308	ECG123A*	25C372	WEP372	121-2900*
	25C300		GE-62	PTC139*	HEP50015*	REN 199	SK3122	RT-302	ECG199	25C900	WEP56	ZEN-119
	25C328		GE-61*	PTC139*	HEP50015*	REN 199	SK3444	RT-302	ECG199	25C828	WEP828	ZEN-119
	25C1740		GE-62	PTC121*	HEP50015*	REN 123A*	SK3122	RT-109*	ECG123A*	25C828	WEP736*	121-972
	25C1415C		GE-66	PTC167	HEP50027	REN 152	SK3054	RT-197	ECG152		WEP745	
	25C325		GE-28	PTC110	HEP50027	REN 136	SK3197	RT-197	ECG186	25C325	WEP751	
	25C1036		GE-28	PTC110	HEP50041	REN 136	SK3197	RT-166	ECG186A	25C1036	WEP1036	
TR35	25C9450Q	2000-235	GE-61*	PTC121*	HEP50015*	REN 199	SK3054	RT-197	ECG186	25C325	WEP745	121-907-02
	25C945A		GE-212	PTC121*	HEP50015*	REN 199	SK3122	RT-107A	ECG199	25C945	WEP1945	121-2900
	25C458		GE-210*	PTC121*	HEP50009*	REN 123A*	SK3122	RT-187	ECG289	25C458	WEP458	121-2900*
	25C372		GE-61*	PTC121*	HEP50015*	REN 123A*	SK3444	RT-308	ECG123A*	25C372	WEP372	121-2900*
	25C300		GE-62	PTC139*	HEP50015*	REN 199	SK3122	RT-302	ECG199	25C900	WEP56	ZEN-119
	25C328		GE-61*	PTC139*	HEP50015*	REN 199	SK3444	RT-302	ECG199	25C828	WEP828	ZEN-119
	25C1740		GE-62	PTC121*	HEP50015*	REN 123A*	SK3122	RT-109*	ECG123A*	25C828	WEP736*	121-972
	25C450C		GE-210*	PTC121*	HEP50009*	REN 123A*	SK3197	RT-187	ECG289	25C458	WEP458	121-2900*
	25C468		GE-210*	PTC121*	HEP50009*	REN 123A*	SK3122	RT-187	ECG289	25C468	WEP468	121-2900*
	25C945		GE-212	PTC121*	HEP50015*	REN 199	SK3122	RT-107A	ECG199	25C945	WEP1945	121-2900
TR36	25C9450Q	2000-235	GE-61*	PTC121*	HEP50015*	REN 123A*	SK3122	RT-107A	ECG199	25C945	WEP1945	121-2900
	25C945A		GE-210*	PTC121*	HEP50009*	REN 123A*	SK3122	RT-187	ECG289	25C458	WEP458	121-2900*
	25C458		GE-210*	PTC121*	HEP50009*	REN 123A*	SK3122	RT-187	ECG289	25C458	WEP458	121-2900*
	25C372		GE-61*	PTC121*	HEP50015*	REN 123A*	SK3444	RT-308	ECG123A*	25C372	WEP372	121-2900*
	25C300		GE-62	PTC139*	HEP50015*	REN 199	SK3122	RT-302	ECG199	25C900	WEP56	ZEN-119
	25C328		GE-61*	PTC139*	HEP50015*	REN 199	SK3444	RT-302	ECG199	25C828	WEP828	ZEN-119
	25C1740		GE-62	PTC121*	HEP50015*	REN 123A*	SK3122	RT-109*	ECG123A*	25C828	WEP736*	121-972
	25C945		GE-212	PTC121*	HEP50015*	REN 199	SK3122	RT-107A	ECG199	25C945	WEP1945	121-2900
	25C468		GE-210*	PTC121*	HEP50009*	REN 123A*	SK3197	RT-187	ECG289	25C468	WEP468	121-2900*
	25C945		GE-212	PTC121*	HEP50015*	REN 199	SK3122	RT-107A	ECG199	25C945	WEP1945	121-2900
TR37	25C9450Q	2000-235	GE-61*	PTC121*	HEP50015*	REN 123A*	SK3122	RT-107A	ECG199	25C945	WEP1945	121-2900
	25C945A		GE-210*	PTC121*	HEP50009*	REN 123A*	SK3122	RT-187	ECG289	25C458	WEP458	121-2900*
	25C458		GE-210*	PTC121*	HEP50009*	REN 123A*	SK3122	RT-187	ECG289	25C458	WEP458	121-2900*
	25C372		GE-61*	PTC121*	HEP50015*	REN 123A*	SK3444	RT-308	ECG123A*	25C372	WEP372	121-2900*
	25C300		GE-62	PTC139*	HEP50015*	REN 199	SK3122	RT-302	ECG199	25C900	WEP56	ZEN-119
	25C328		GE-61*	PTC139*	HEP50015*	REN 199	SK3444	RT-302	ECG199	25C828	WEP828	ZEN-119
	25C1740		GE-62	PTC121*	HEP50015*	REN 123A*	SK3122	RT-109*	ECG123A*	25C828	WEP736*	121-972
	25C945		GE-212	PTC121*	HEP50015*	REN 199	SK3122	RT-107A	ECG199	25C945	WEP1945	121-2900
	25C468		GE-210*	PTC121*	HEP50009*	REN 123A*	SK3197	RT-187	ECG289	25C468	WEP468	121-2900*
	25C945		GE-212	PTC121*	HEP50015*	REN 199	SK3122	RT-107A	ECG199	25C945	WEP1945	121-2900
TR38	25C1973	2000-210	GE-335	PTC186	HEP50009*	REN 235	SK3250	RT-146	ECG235	25C773	WEP773	
	25C1306		GE-215	PTC186	HEP50009*	REN 235	SK3197	RT-146	ECG235	25C1306	WEP1306	
	25C2020		GE-215	PTC186	HEP50009*	REN 235	SK3197	RT-146	ECG235	25C1306	WEP1306	
	25C2184		GE-215	PTC186	HEP50009*	REN 235	SK3197	RT-146	ECG235	25C1306	WEP1306	
	25L2156		GE-215	PTC186	HEP50009*	REN 235	SK3197	RT-146	ECG235	25C1306	WEP1306	
	25L195-3		GE-57	PTC163	HEP50009*	REN 295	SK3251	RT-162	ECG255	25C496	WEP496	
	25L456		GE-57	PTC163	HEP50009*	REN 295	SK3251	RT-162	ECG255	25C496	WEP496	
	25L1846		GE-335	PTC904	HEP50009*	REN 295	SK3251	RT-162	ECG255	25C496	WEP496	
	25Q471		GE-268	PTC144*	HEP50031*	REN 289	SK3124	RT-114*	ECG269		WEP910	800-757
	25C2236		GE-268	PTC144*	HEP50031*	REN 289	SK3124	RT-114*	ECG269		WEP910	121-1014
TR41	25C1969B	2000-242	GE-215	PTC186	HEP50015*	REN 235	SK3197	RT-158	ECG236	25C1969	WEP1969	121-1014
	25C1969		GE-215	PTC186	HEP50015*	REN 235	SK3197	RT-158	ECG236	25C1969	WEP1969	121-1014
	25C1307		GE-215	PTC186	HEP50015*	REN 235	SK3197	RT-158	ECG236	25C1307	WEP1307	
	25L1817		GE-215	PTC186	HEP50015*	REN 235	SK3239	RT-158	ECG236	25C1307	WEP1307	
	25C2043		GE-215	PTC186	HEP50015*	REN 235	SK3239	RT-158	ECG236	25C1307	WEP1307	
	25C2195		GE-216	PTC186	HEP50015*	REN 235	SK3239	RT-158	ECG236	25C1307	WEP1307	
	25C1675L		GE-213	PTC132*	HEP50025*	REN 123A*	SK3246	RT-308	ECG229*	25C1675	WEP1675	ZEN-127
	25C1675		GE-213	PTC132*	HEP50025*	REN 123A*	SK3246	RT-308	ECG229*	25C1675	WEP1675	ZEN-127
	25C460		GE-214	PTC132*	HEP50025*	REN 161	SK3133*	RT-134	ECG316*	25C460	WEP460	ZEN-104
	25C839		GE-61*	PTC132*	HEP50015*	REN 123A*	SK3444	RT-308	ECG123A*	25C839	WEP839	121-2900*
TR42	25C1674	2000-213	GE-61	PTC132*	HEP50015*	REN 123A*	SK3444	RT-308	ECG123A*	25C839	WEP839	121-2900*
	25C1730		GE-62	PTC121*	HEP50015*	REN 123A*	SK3122	RT-109*	ECG123A*	25C839	WEP839	121-972

* Lead configuration may vary from original.

ELECTROLYTIC CAPACITORS

ITEM No.	RATING	REPLACEMENT DATA				
		MFG. PART No.	CORNELL-DUBILIER PART No.	MALLORY PART No.	SPRAGUE PART No.	
					Q-LINE	GENERAL LINE
C7	.22 16V	1800-503		TDK2748050FL	Q0T1-10	S050-R229
C13	.1 25V	1800-509		TDK104M050FL	Q0T1-2	S050-R139
C15	2.2 25V	1800-303	PC2-100	YTT282A50	QW1-19	EV-1617
C18	.47 50V	1800-301	PC1-50	YTT47A63	QW1-3	EV-1610
C17	.47 50V	1800-301	PC1-50	YTT47A63	QW1-3	EV-1610
C19	.22 16V	1800-503		TDK224M050EL	Q0T1-10	S050-R220
C24	.47 10V	1800-324	PC50-16	YTT47D16	QW1-73	EV-1226
C25	.47 10V	1800-324	PC50-16	YTT47D16	QW1-73	EV-1226
C27	.47 50V	1800-301	PC1-50	YTT47A63	QW1-3	EV-1610
C59	1 25V	1800-506		TDK105M035EL		S035-19
C62	2.2 25V	1800-503		TDK225M035FL		S035-2R29
C63	2.2 25V	1800-503		TDK225M035FL		S035-2R29
C66	1000 10V	1800-332	PC1000-15	YTT1000L10	QW1-119	EV-1150
C72	.47 10V	1800-507		TDK475M010EL	Q0T1-48	S010-4R70
C73	.47 25V	1800-304	PC5-50	YTT4R7950	QW1-27	EV-1319
C83	2.2 25V	1800-303	PC2-100	YTT282A50	QW1-19	EV-1617
C84	22 5.3V	1800-610		TDK225M015FL	Q0T1-62	S015-224
C90	10 16V	1800-306	PC10-25	YTT10825	QW1-41	EV-1822
C92	.47 10V	1800-324	PC50-16	YTT47D16	QW1-73	EV-1226
C107	220 10V	1800-525	PC250-17*	YTT220F10	QW1-115	EV-1140
C109	.1 25V	1800-609		TDK104M050FL	Q0T1-2	S050-R109

ELECTROLYTIC CAPACITORS (cont)

ITEM No.	RATING	REPLACEMENT DATA				
		MFR. PART No.	CORNELL-DUBILIER PART No.	MALLORY PART No.	SPRAGUE PART No.	
					Q-LINE	GENERAL LINE
C112	4.7 25V	1800-304	PC5-50	VTT4R7050	QV1-27	EV-1319
C113	22 6.3V	1800-610		TOC226M015FL	QV1-62	5015-229
C114	47 10V	1800-324		VTT47016	QV1-73	EV-1226
C117	10 25V	1000-330	PC50-16	VTT10B25	QV1-43	EV-1322
C118	470 10V	1800-327	PC10-25	VTT10B25	QV1-149	EV-1150
C119	1 50V	1800-302	PC500-16	VTT1470K15	QV1-11	EV-1515
C120	10 16V	1800-306	PC1-50	VTT1A50	QV1-41	EV-1222
C121	.47 50V	1800-301	PC10-25	VTT10B25	QV1-3	EV-1510
C133	10 16V	1000-306	PC1-50	VTT10B25	QV1-41	EV-1222
C134	1000 25V	1800-333	4SR1000-25*	VTT1000M25	QV1-195	EV-1360
C142	.47 50V	1800-301	PC1-50	VTT1000M25	QV1-3	EV-1510
C145	1 50V	1800-302	PC1-50	VTT1A50	QV1-11	EV-1515
C162	1 50V	1800-302	PC1-50	VTT1A50	QV1-11	EV-1515
C164	10 25V	1000-330	PC10-25	VTT10B25	QV1-43	EV-1322
C169	1 50V	1800-302	PC1-50	VTT1A50	QV1-11	EV-1515
C180	22 10V	1800-331	PC25-25	VTT25R15	QV1-55	EV-1224
C191	47 10V	1800-324	PC50-16	VTT47016	QV1-73	EV-1226
C193	1 25V	1800-606		TOC105M035CL		3035-19
C434	47 10V	1800-324	PC50-16	VTT47016	QV1-73	EV-1226

* Axial replacement for radial device.

CAPACITORS

ITEM No.	RATING	MFR. PART No.	REPLACEMENT DATA				
			CENTRALAB PART No.	CORNELL-DUBILIER PART No.	MALLORY PART No.	SPRAGUE PART No.	
						Q-LINE	GENERAL LINE
C1	.022 50V		DC-203	MGP02	TA120	OC2-157	TG-520
C2	.022 50V		DC-203	MGP02	TA120	OC2-157	TG-520
C3	.001 50V		DD-102G	GP1000	GP210	OC2-81	56A-010
C4	.022 50V		DC-203	MGP02	TA120	OC2-157	TG-520
C5	.022 50V		DC-203	MGP02	TA120	OC2-157	TG-520
C6	.001 50V		DD-102G	GP1000	GP210	OC2-81	56A-010
C8	52 NPO 50V		DTZ-82	NP082	CN0462		10TCC-082
C9	.001 50V		DC-103	MGP01	TA110	OC2-141	TG-510
C10	100 N220 50V	1800-009			*		10TCR-T10
C11	.022 50V		DC-203	MGP02	TA120	OC2-157	TG-520
C12	.022 50V		DC-203	MGP02	TA120	OC2-157	TG-520
C14	.022 50V		DC-203	MGP02	TA120	OC2-157	TG-520
C18	.022 50V		DC-203	MGP02	TA120	OC2-157	TG-520
C20	.022 50V		DC-203	MGP02	TA120	OC2-157	TG-520
C21	5 NPO 50V		DTZ-4R7	NP04P7	CN0547		10TCC-V47
C22	3 NPO 50V		DTZ-3R3	NP03P3	CN0533		10TCC-V33
C23	3 NPO 50V		DTZ-3R3	NP03P3	CN0533		10TCC-V33
C25	.033 50V			DPMS6533	EMF6133		6PS-533
C28	.1 50V			DPMS2P1	EMF1A010	QF1-215	1PB-P10
C29	12 NPO 50V				CN0412		10TCC-Q12
C30	.001 50V		DD-102G	GP1000	GP210	OC2-81	56A-010
C31	.001 50V		DD-102G	GP1000	GP210	OC2-81	56A-010
C32	.001 50V		DD-102G	GP1000	GP210	OC2-81	56A-010
C33	.0047 50V		DD-472	GP4700	GP247		56A-047
C34	.001 50V		DD-102G	GP1000	GP210	OC2-81	56A-010
C35	.0047 50V		DD-472	GP4700	GP247		56A-047
C36	4 NPO 50V		DTZ-4R7	NP04P7	CN0547		10TCC-V47
C37	.0047 50V		DD-472	GP4700	GP247		56A-047
C38	2 NPO 50V		DTZ-2R2	NP02P2	CN0522		10TCC-V22
C39	.001 50V		DD-102G	GP1000	GP210	OC2-81	56A-010
C40	.001 50V		DD-102G	GP1000	GP210	OC2-81	56A-010
C41	.001 50V		DD-102G	GP1000	GP210	OC2-81	56A-010
C42	2 NPO 50V		DTZ-2R2	NP02P2	CN0522		10TCC-V22
C43	33 NPO 50V		DTZ-33	NP033	CN0433		10TCC-C33
C44	2 NPO 50V		DTZ-2R2	NP02P2	CN0522		10TCC-V22
C45	.022 50V		DC-203	MGP02	TA120	OC2-157	TG-520
C46	.022 50V		DC-203	MGP02	TA120	OC2-157	TG-520
C47	.022 50V		DC-203	MGP02	TA120	OC2-157	TG-520
C48	.01 50V		DC-103	MGP01	TA110	OC2-141	TG-510
C49	.022 50V		DC-203	MGP02	TA120	OC2-157	TG-520
C50	.022 50V		DC-203	MGP02	TA120	OC2-157	TG-520
C51	.022 50V		DC-203	MGP02	TA120	OC2-157	TG-520
C52	.022 50V		DC-203	MGP02	TA120	OC2-157	TG-520
C54	.047 50V			DPMS2547	EMF1A147	QF1-171	1PB-547
C55	.022 50V			DPMS2522	EMF1A122	QF1-122	1PB-522
C56	.022 50V		DC-203	MGP02	TA120	OC2-157	TG-520
C57	27 NPO 50V				CN0427		10TCC-Q27
C58	.001 50V			DPMS6D1	EMF1A210	QF1-1	1PB-010
C50	.01 50V		DC-103	MGP01	TA110	OC2-141	TG-510
C61	.1 50V			DPMS2P1	EMF1A010	QF1-215	1PB-P10
C64	18 NPO 50V				CN0418		10TCC-Q18
C65	10 NPO 50V		DTZ-10	NP010	CN0410		10TCC-Q10
C67	.01 50V		DC-103	MGP01	TA110	OC2-141	TG-510
C68	.022 50V		DC-203	MGP02	TA120	OC2-157	TG-520
C69	47 NPO 50V		DTZ-47	NP047	CN0447		10TCC-Q47

CAPACITORS (cont)

ITEM No.	RATING	MFR. PART No.	REPLACEMENT DATA				
			CENTRALAB PART No.	CORNELL-DUBILIER PART No.	MALLORY PART No.	SPRAGUE PART No.	
						Q LINE	GENERAL LINE
C70	47 NPO 50V		DTZ-47	NP047	CND447		10TCC-047
C71	.047 50V			DFMS2547	EMF1A147	QF1-171	1PB-547
C74	.01 50V		DC-103	NGP01	TA110	QC2-141	TG-S10
C75	.01 50V		DC-103	NGP01	TA110	QC2-141	TG-S10
C76	15 NPO 50V		DTZ-15	NP015	CND415		10TCC-015
C77	.01 50V		DC-103	NGP01	TA110	QC2-141	TG-S10
C78	.01 50V		DC-103	NGP01	TA110	QC2-141	TG-S10
C79	.1 50V			DFMS2P1	EMF1A010	QF1-215	1PB-P10
C80	4 NPO 50V		DTZ-4R7	NP0MP7	CND547		10TCC-V47
C81	270 N750 50V				CN7327		10TCU-T27
C82	.0047 50V			WFF1D47	EMF1A247	QF1-57	1PB-047
C85	.0047 50V			WFF1D47	EMF1A247	QF1-57	1PB-047
C86	.033 50V			DFMS6533	EMF6133		6FS-533
C87	.022 50V		DC-203	NGP02	TA120	QC2-157	TG-S20
C88	.047 50V			DFMS2547	EMF1A147	QF1-171	1PB-547
C89	.01 50V			WFF1S1	EMF1A110	QF1-91	1PB-S10
C91	.0022 50V			DFMS6022	EMF6222		6FS-022
C93	.01 50V			WFF1S1	EMF1A110	QF1-91	1PB-S10
C94	.01 50V		DC-103	NGP01	TA110	QC2-141	TG-S10
C95	.01 50V		DC-103	NGP01	TA110	QC2-141	TG-S10
C98	.001 50V		DD-1026	GP1000	GP210	QC2-R1	5GA-D10
C99	.01 50V		DC-103	NGP01	TA110	QC2-141	TG-S10
C100	.01 50V		DC-103	NGP01	TA110	QC2-141	TG-S10
C101	.001 50V		DD-1026	GP1000	GP210	QC2-B1	5GA-D10
C102	100 NPO 50V		DTZ-100	NP0100	LM0310		10TCC-T10
C103	.01 50V		DC-103	NGP01	TA110	QC2-141	TG-S10
C104	18 NPO 50V			NP018	CND418		10TCC-018
C105	10 NPO 50V		DTZ-10	NP010	CND410		10TCC-010
C106	.01 50V		DC-103	NGP01	TA110	QC2-141	TG-S10
C108	.047 50V			DFMS2547	EMF1A147	QF1-171	1PB-547
C110	.1 50V			DFMS2P1	EMF1A010	QF1-215	1PB-P10
C111	.022 50V			DFMS2S22	EMF1A122	QF1-127	1PB-S22
C115	.001 50V			DFMS601	EMF1A210	QF1-1	1PB-010
C116	.1 50V			DFMS2P1	EMF1A010	QF1-215	1PB-P10
C122	.01 50V		DC-103	NGP01	TA110	QC2-141	TG-S10
C123	.01 50V		DC-103	NGP01	TA110	QC2-141	TG-S10
C124	.01 50V		DC-103	NGP01	TA110	QC2-141	TG-S10
C125	.01 50V		DC-103	NGP01	TA110	QC2-141	TG-S10
C126	10 NPO 50V		DTZ-10	NP010	CND410		10TCC-010
C127	220 50V		30-221		GP322		10T5-T22
C128	470 50V		30-471	GP470	GP347		10T5-T47
C129	.01 50V		DC-103	NGP01	TA110	QC2-141	TG-S10
C130	.01 50V		DC-103	NGP01	TA110	QC2-141	TG-S10
C131	.01 50V		DC-103	NGP01	TA110	QC2-141	TG-S10
C132	.01 50V		DTZ-10	NP010	CND410		10TCC-010
C135	.0047 50V		30-472	GP4700	GP247		5GA-047
C136	.0047 50V		30-472	GP4700	GP247		5GA-047
C137	.0047 50V		30-472	GP4700	GP247		5GA-047
C138	.0047 50V		30-472	GP4700	GP247		5GA-047
C139	.1 NPO 50V				CND510		10TCC-V10
C140	10 NPO 50V		DTZ-10	NP010	CND410		10TCC-010
C141	.0047 50V		30-472	GP4700	GP247		5GA-047
C143	50 NPO 50V		DTZ-50	NP050	CND450		10TCC-050
C144	30 NPO 50V				CND430		10TCC-030
C145	180 N220 50V	1800-116					10TCR-018
C147	1 NPO 50V				CND510		10TCC-V10
C148	390 N750 50V		DTN-390				10TCU-T39
C149	330 N750 50V			DFMS601	EMF210		6FS-010
C150	.1 50V			DFMS2P1	EMF1A010	QF1-215	1PB-P10
C151	470 N750 50V		DTN-470				10TCU-T47
C152	.0047 50V		30-472	GP4700	GP247		5GA-047
C153	.1 50V			DFMS2P1	EMF1A010	QF1-215	1PB-P10
C154	.0047 50V		30-472	GP4700	GP247		5GA-047
C155	.0047 50V		30-472	GP4700	GP247		5GA-047
C156	.0047 50V		30-472	GP4700	GP247		5GA-047
C157	.0047 50V		30-472	GP4700	GP247		5GA-047
C158	47 NPO 50V		DTZ-47	NP047	CND447		10TCC-047
C159	330 N750 50V		DTN-330	N330	CN7333		10TCU-T33
C160	1.5 NPO 50V		DTZ-1R5	NP01P5	CND515		10TCC-V15
C161	.01 50V			WFF1S1	EMF1A110	QF1-91	1PB-S10
C163	120 N220 50V	1800-121					10TCR-T12
C165	.001 50V		30-1026	GP1000	GP210	QC2-81	5GA-D10
C166	18 NPO 50V			NP018	CND418		10TCC-018
C167	.022 50V		DC-203	NGP02	TA120	QC2-157	TG-S20
C168	.047 50V			DFMS2547	EMF1A147	QF1-171	1PB-547
C170	100 50V		30-101	GP100	GP310		10T5-T10
C171	55 NPO 50V				CND455		10TCC-055
C172	.001 50V		30-1026	GP1000	GP210	QC2-01	5GA-D10
C173	.0047 50V		30-472	GP4700	GP247		5GA-047
C174	330 N750 50V		DTN-330	N330	CN7333		10TCU-T33
C175	33 NPO 50V		DTZ-33	NP033	CND433		10TCC-033
C176	.001 50V		30-1026	GP1000	GP210	QC2-81	5GA-D10
C177	.022 50V		DC-203	NGP02	TA120	QC2-157	TG-S20
C178	.001 50V		30-1026	GP1000	GP210	QC2-81	5GA-D10
C181	.01 50V		DC-103	NGP01	TA110	QC2-141	TG-S10

CAPACITORS (cont)

ITEM No.	RATING	MFR. PART No.	REPLACEMENT DATA				
			CENTRALAB PART No.	CORNELL-DUBILIER PART No.	MALLORY PART No.	SPRAGUE PART No.	
						G-LINE	GENERAL LINE
C192	.047 50V		DC-503	MGP05	TA150	CC2-207	TG-590
C199	.01 50V		DC-103	MGP01	TA110	CC2-141	TG-510
C190	.047 50V		DC-503	MGP05	TA150	CC2-207	TG-590
C192	.001 50V		DD-1026	GP1000	SP210	CC2-81	56A-D10
C194	.033 50V			DFM56533	EMF6133		6A5-533
C195	47 NFO 50V		DT2-47	NFO47	CND47		10TCC-047
C202	.0047 50V		DD-472	GP4700	GP247		56A-D47
C203	.0047 50V		DD-472	GP4700	GP247		56A-D47
C204	.0047 50V		DD-472	GP4700	GP247		56A-D47
C205	.0047 50V		DD-472	GP4700	GP247		56A-D47
C206	.022 50V		DC-203	MGP02	TA120	CC2-157	TG-520
C207	.1 50V		DC-104	MGP1	TA010	CC2-233	TG-P10
C208	.022 50V		DC-203	MGP02	TA120	CC2-157	TG-S20
C401	.01 50V		DC-103	MGP01	TA110	CC2-141	TG-S10
C402	.022 50V		DC-203	MGP02	TA120	CC2-157	TG-S20
C403	.001 50V		DD-1025	GP1000	GP210	CC2-81	56A-D10
C404	.001 50V		DD-1025	GP1000	GP210	CC2-81	56A-D10
C405	.001 50V		DD-1026	GP1000	GP210	CC2-81	56A-D10
C406	.001 50V		DD-1026	GP1000	GP210	CC2-81	56A-D10
C407	.001 50V		DD-1026	GP1000	GP210	CC2-81	56A-D10
C415	.001 50V		DD-1026	GP1000	GP210	CC2-81	56A-D10
C435	.022 50V		DC-203	MGP02	TA120	CC2-157	TG-S20
C436	.0047 50V			MNF1047	DMF1247	DF1-57	1PB-D47
C437	22 50V		DT2-22	RPC22	CW422		10TCC-022
C67	50V	1800-103					
C11	20 50V	1800-203					
C12	20 50V	1800-203					
C13	20 50V	1800-203					

*Not normally in distributor's stock. Available thru distributor on order to manufacturer.

CONTROLS (All wattages 1/2 watt, or less, unless listed)

ITEM No.	FUNCTION	RESISTANCE	REPLACEMENT DATA			
			MFR. PART No.	CENTRALAB PART No.	MALLORY PART No.	TRW PART No.
VR1	Sig Meter	10K	1900-203	T-10K(3)	MTC14L1(3)	U25CR103B
VR2	Squelch Range	1000	1900-230			U25CR102B
VR3	LSB XMT	3000	1900-215			U25CR503B
VR5	Carrier Balance	10K	1900-203	T-10K(3)	MTC14L1(3)	U25CR103B
VR6	AM Power	5000	1900-201			U25CR502B
VR7	RF ALC	10K	1900-203	T-10K(3)	MTC14L1(3)	U25CR103B
VR8	RF Driver Bias	500	1900-235			U25CR501B
VR9	RF Final Bias	5000	1900-201			U25CR502B
VR10	TX Power Meter	100K	1900-211			U25CR104B
VR401	Squelch	100K	1900-121(18)			
VR403	Volume/Power Switch	10K				
VR402	Clarifier	20K	1900-126			
VR404	RF Gain	10K	1900-127(19)			
VR405	Mix Gain	10K				

(3) For horizontal mounting, bend the two outside terminals to fit PC board. Use jumper to connect center terminal to PC board.

(18) Includes VR401, VR403 and Power Switch.

(19) Includes VR404 and VR405.

COILS (RF-IF)

ITEM No.	FUNCTION	REPLACEMENT DATA			REMARKS
		PART No.	OTHER IDENTIFICATION	MILLER PART No.	
L1	Noise Blanker (23MHz)	2200-022	LA038	CBS512-7TC	
L2	Noise Blanker (23MHz)	2200-029	LA179		
L3	IF (7.8MHz)	2200-064	LA255		
L4	IF (7.8MHz)	2200-065	LA253		
L5	IF (7.8MHz)	2200-066	LA262		
L6	IF (7.8MHz)	2200-067	LA257		
L7	IF (7.8MHz)	2200-068	LA258		
L8	Rec RF (27MHz)	2200-069	LA259		
L9	Rec RF (27MHz)	2200-070	LA260		
L10	Rec Ant (27MHz)	2200-071	LA261		

COILS (RF-IF) (cont)

ITEM No.	FUNCTION	REPLACEMENT DATA			REMARKS
		PART No.	OTHER IDENTIFICATION	MILLER PART No.	
L11	RF Choke (270uH)	2200-040	L2012-4		
L12	RF Choke (100uH)	2200-202	L2012-1		
L13	VCO	2200-072	LA216		
L14	VCO (34MHz)	2200-065	LA195		
L15	RF Choke (470uH)	2200-040	L2012-4		
L16	RF Choke (470uH)	2200-040	L2012-4		
L17	Carrier Shift (2.8MHz)	2200-073	LA223		
L18	Trippole (35MHz)	2200-074	LA256		
L19	Osc (11.1125MHz)	2200-075	LA217		
L20	Osc (11.1125MHz)	2200-076	LA218		
L21	RF Choke (470uH)	2200-040	L2012-4		
L22	RF Choke (470uH)	2200-040	L2012-4		
L23	RF Choke (470uH)	2200-040	L2012-4		
L24	RF Choke (470uH)	2200-040	L2012-4		
L25	RF Choke (100uH)	2200-202	L2012-1		
L26	Balance Mix (78MHz)	2200-077	LA219		
L27	Balance Mix (35 Hz)	2200-028	LA150		
L28	Mixer (27MHz)	2200-078	LA220		
L29	Mixer (27MHz)	2200-079	LA254		
L30	ANT Driver (27MHz)	2200-061	LD095		
L31	RF Choke	2200-060	LD096		
L35	RF Choke	2200-060	L3098		
L36	Final	2200-034	LC019	CE305	
L37	RF Choke	2200-038	LC051		
L38	RF Choke	2200-036	LC051		
L39	TVI Trap (54MHz)	2200-034	LC019	CE305	
L401	RF Choke	2200-035	LD013		
L402	RF Choke	2200-035	LD013		
L403	RF Choke	2200-059	LD069		

FILTER CHOKE

ITEM No.	RATINGS			REPLACEMENT DATA			NOTES
	CURRENT (Measured)	DC RES.	INDUCTANCE (DC CURRENT 1000→)	MFR. PART No.	THORDARSON PART No.	TRIAD PART No.	
T1	2.8	.194	2.25mH	TF-151(1)			(1) Number on unit.

SPEAKER

ITEM No.	TYPE	REPLACEMENT DATA		NOTES
		MFR. PART No.	QUAM PART No.	
SP401	3 1/2" PH 8 Ohms	3103-007	3A0528	

EURO PRESIDENT MODEL 1011001 Mc KINLEY

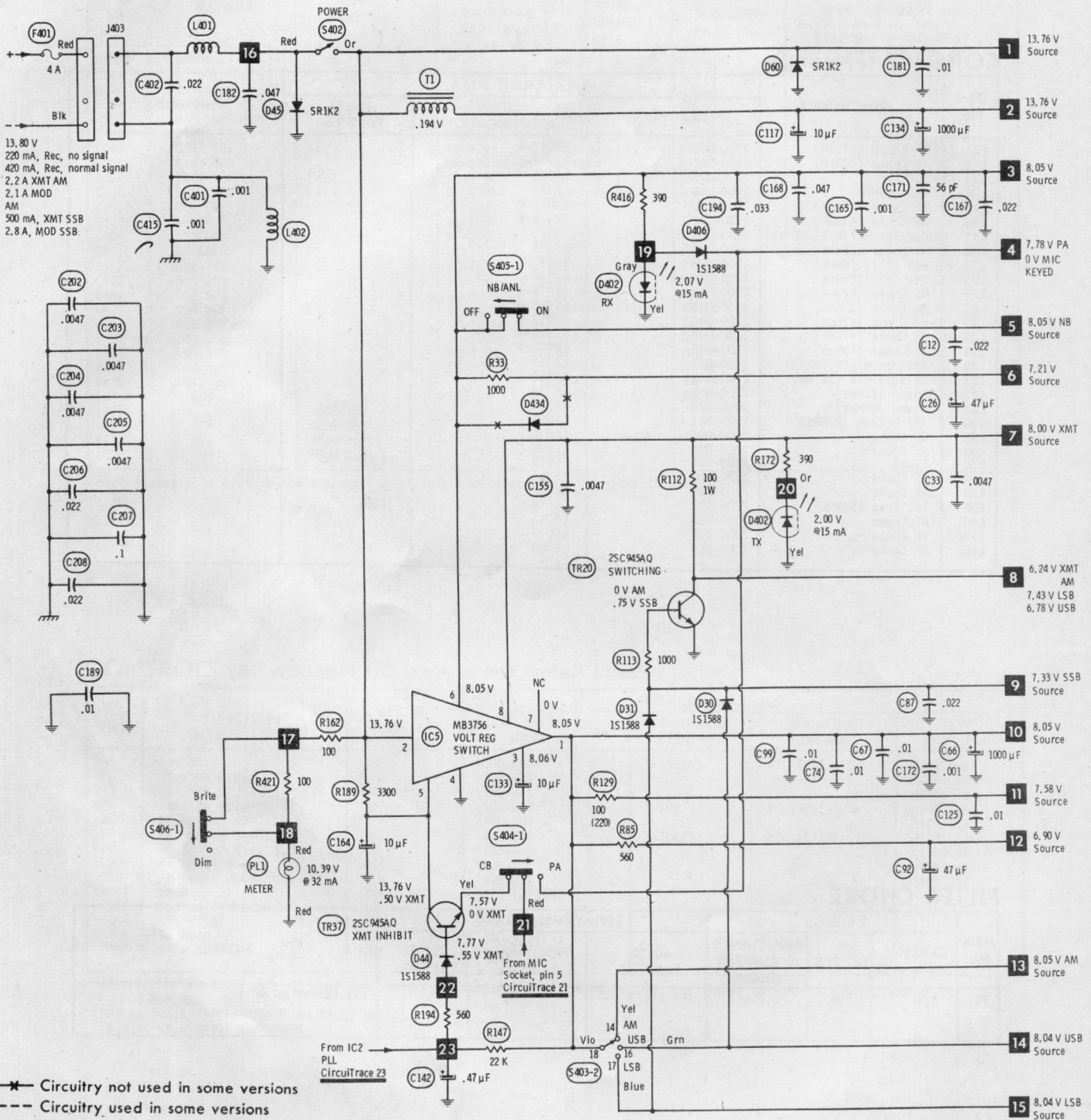

- Circuitry not used in some versions
- - - Circuitry used in some versions
- ⊙ See parts list
- ⊛ Nominal value
- ⊕ Ground
- ⊞ Chassis
- ▽ Common tie point

Measurements made in Channel 1 with switching as shown unless noted. Item numbers in rectangles appear in the alignment/adjustment instructions. Supply voltage maintained as shown at input. Voltages measured with digital meter, no signal. Controls adjusted for normal operation. Arrow at control indicates direction of advance. Terminal identification may not be found on unit. Resistors are 1/2W or less, 5% unless noted. Value in () used in some versions.

A PHOTOFAC STANDARD NOTATION SCHEMATIC

WITH **CIRCUITRACE**

© Howard W. Sams & Co., Inc. 1978

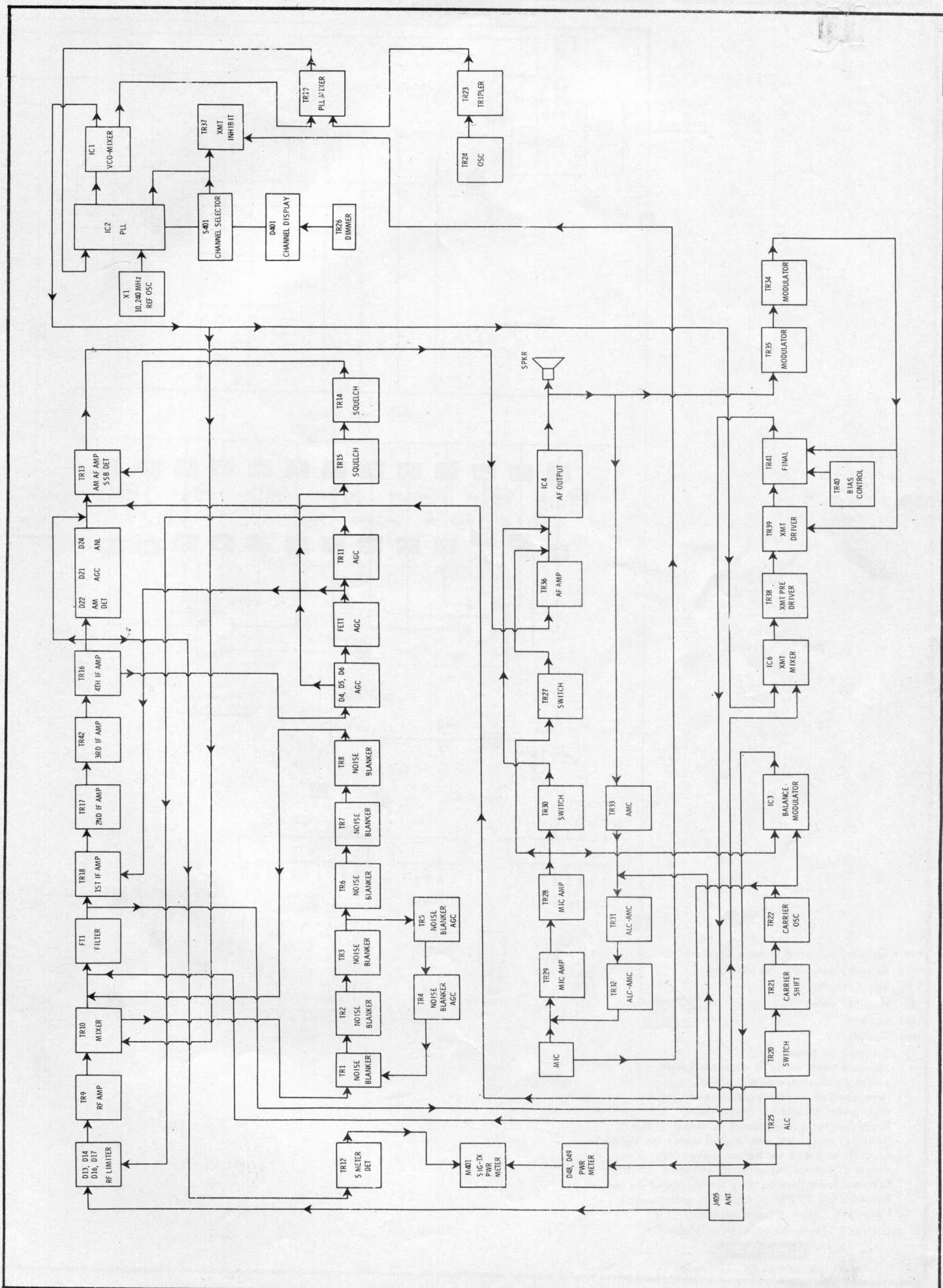

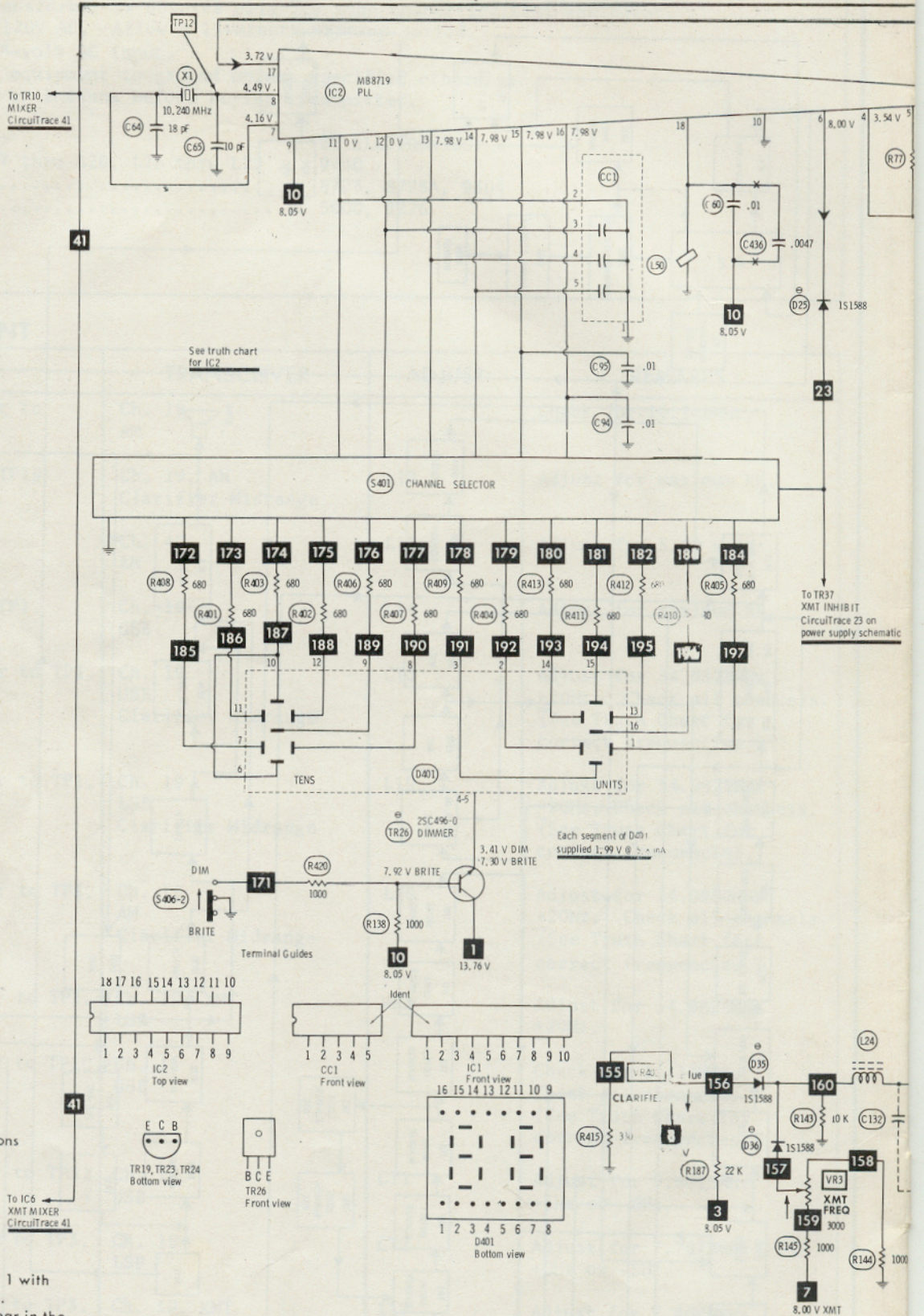

- ✖ Circuitry not used in some versions
 - Circuitry used in some versions
 - ⊕ See parts list
 - ⊛ Nominal value
 - ⊕ Ground
 - ⊕ Chassis
 - ▽ Common tie point
- Measurements made in Channel 1 with switching as shown unless noted. Item numbers in rectangles appear in the alignment/adjustment instructions. Supply voltage maintained as shown at input. Voltages measured with digital meter, no signal. Controls adjusted for normal operation. Arrow at control indicates direction of advance. Terminal identification may not be found on unit. Resistors are 1/2W or less, 5% unless noted. Value in () used in some versions.

A PHOTOFACIT STANDARD NOTATION SCHEMATIC

WITH **CircuitTrace**

© Howard W. Sams & Co., Inc. 1978

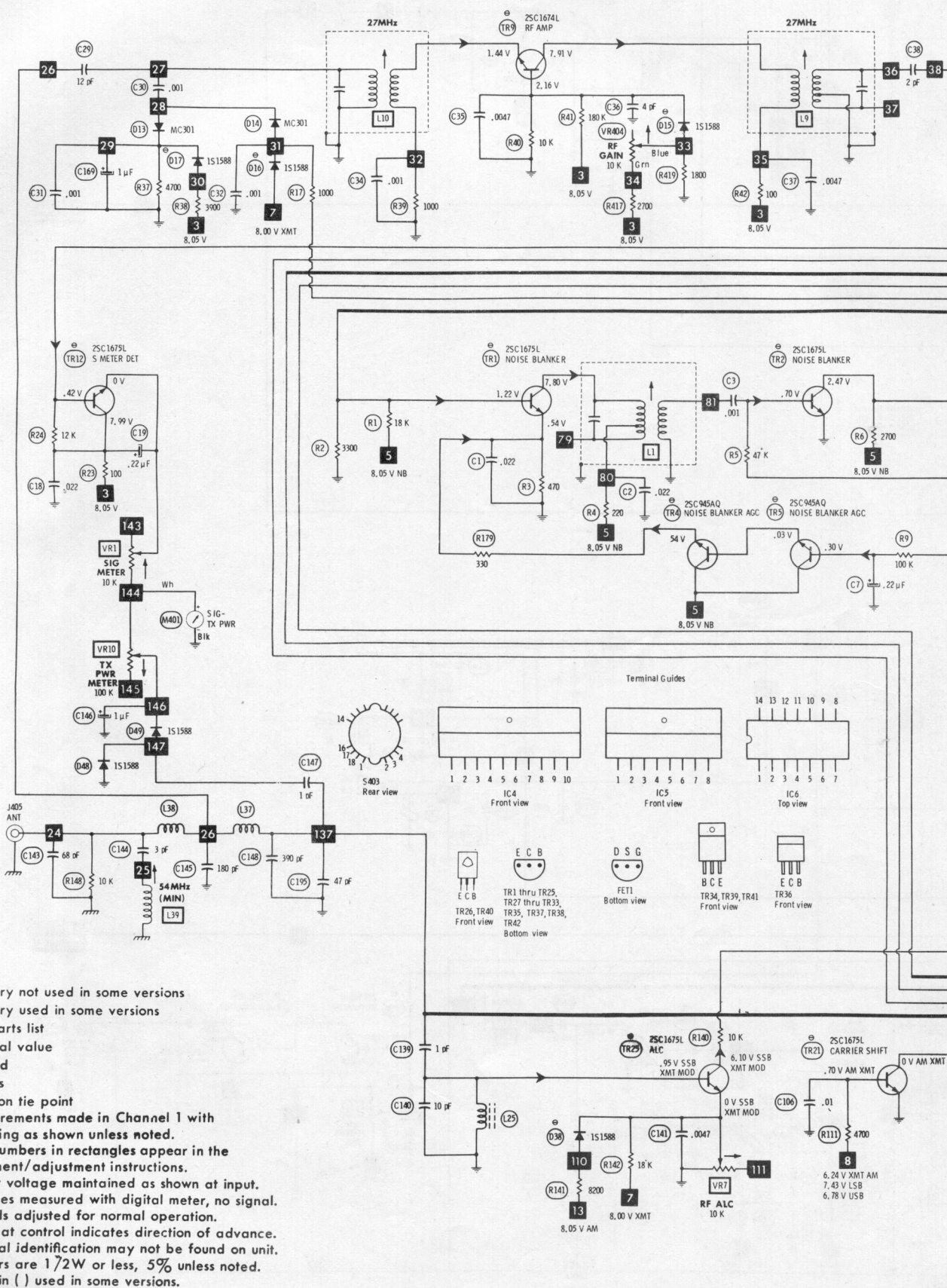

* Circuitry not used in some versions
 - - - Circuitry used in some versions
 ⊕ See parts list
 * Nominal value
 ⊕ Ground
 ▭ Chassis
 ▽ Common tie point
 Measurements made in Channel 1 with switching as shown unless noted.
 Item numbers in rectangles in the alignment/adjustment instructions.
 Supply voltage maintained as shown at input.
 Voltages measured with digital meter, no signal.
 Controls adjusted for normal operation.
 Arrow at control indicates direction of advance.
 Terminal identification may not be found on unit.
 Resistors are 1/2W or less, 5% unless noted.
 Value in () used in some versions.

A PHOTOFAC STANDARD NOTATION SCHEMATIC
 WITH **CIRCUITRACE**[®]
 © Howard W. Sams & Co., Inc. 1978

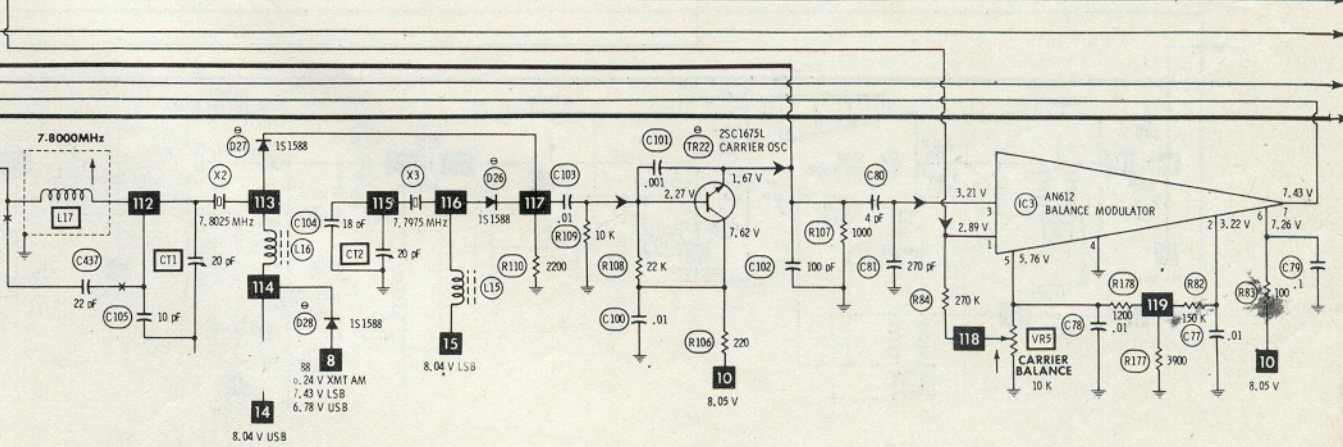
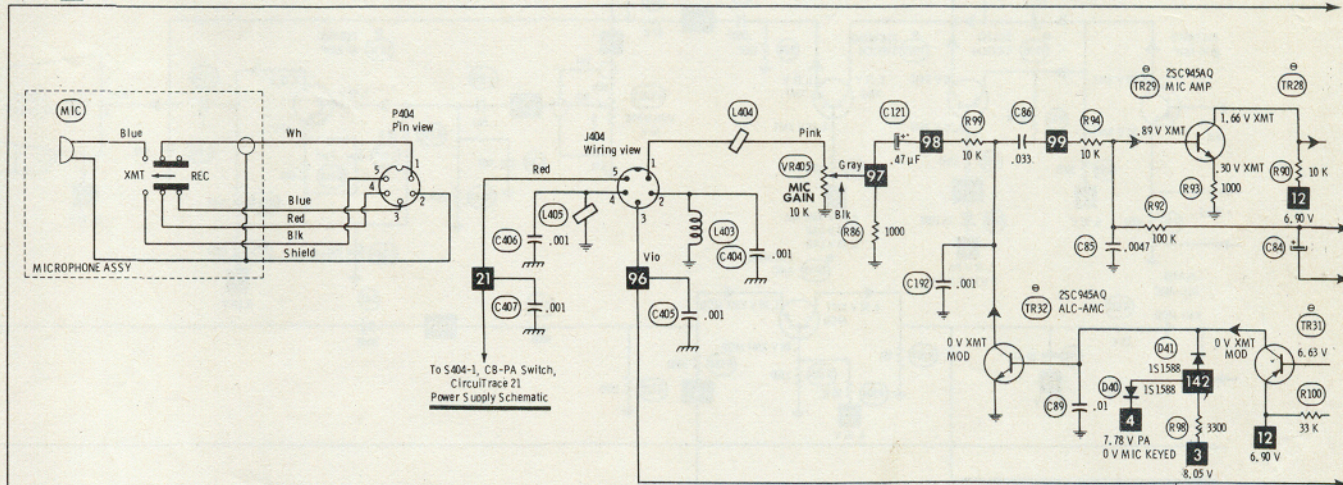
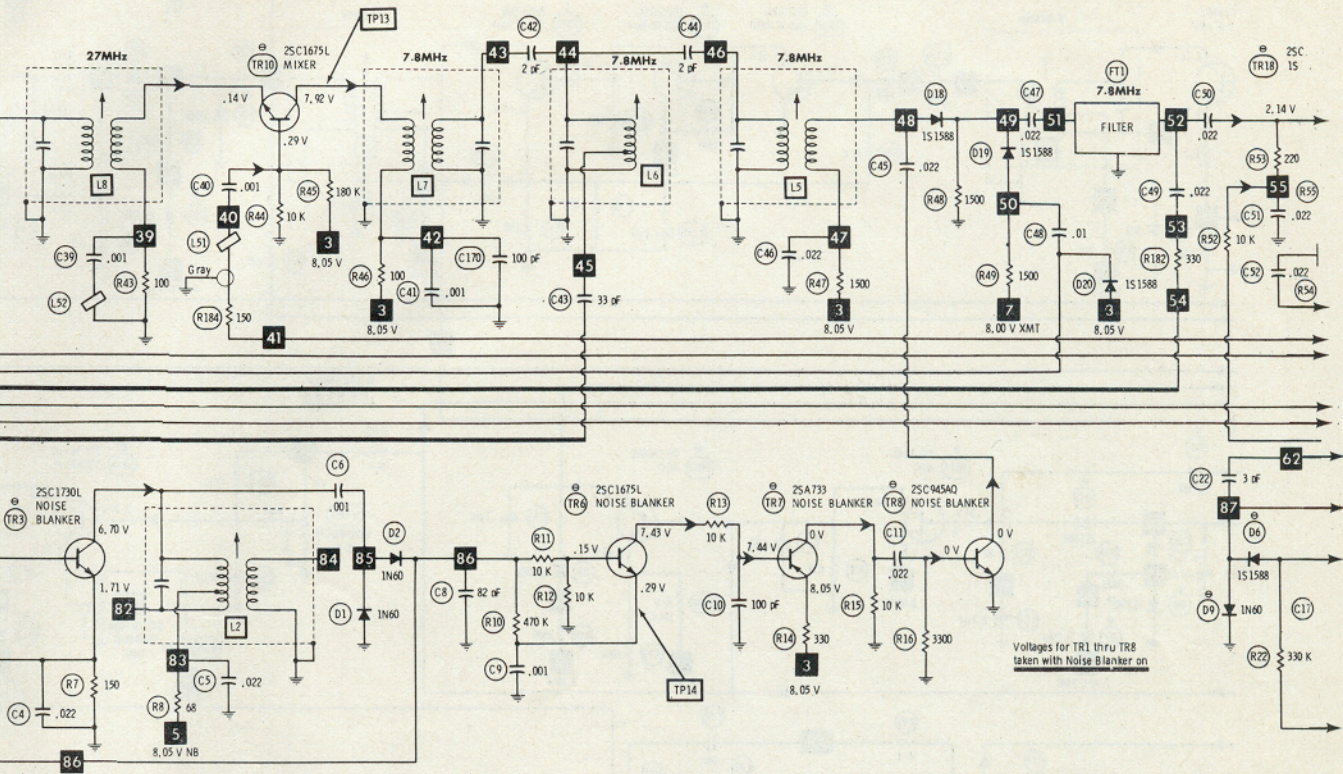

1/20

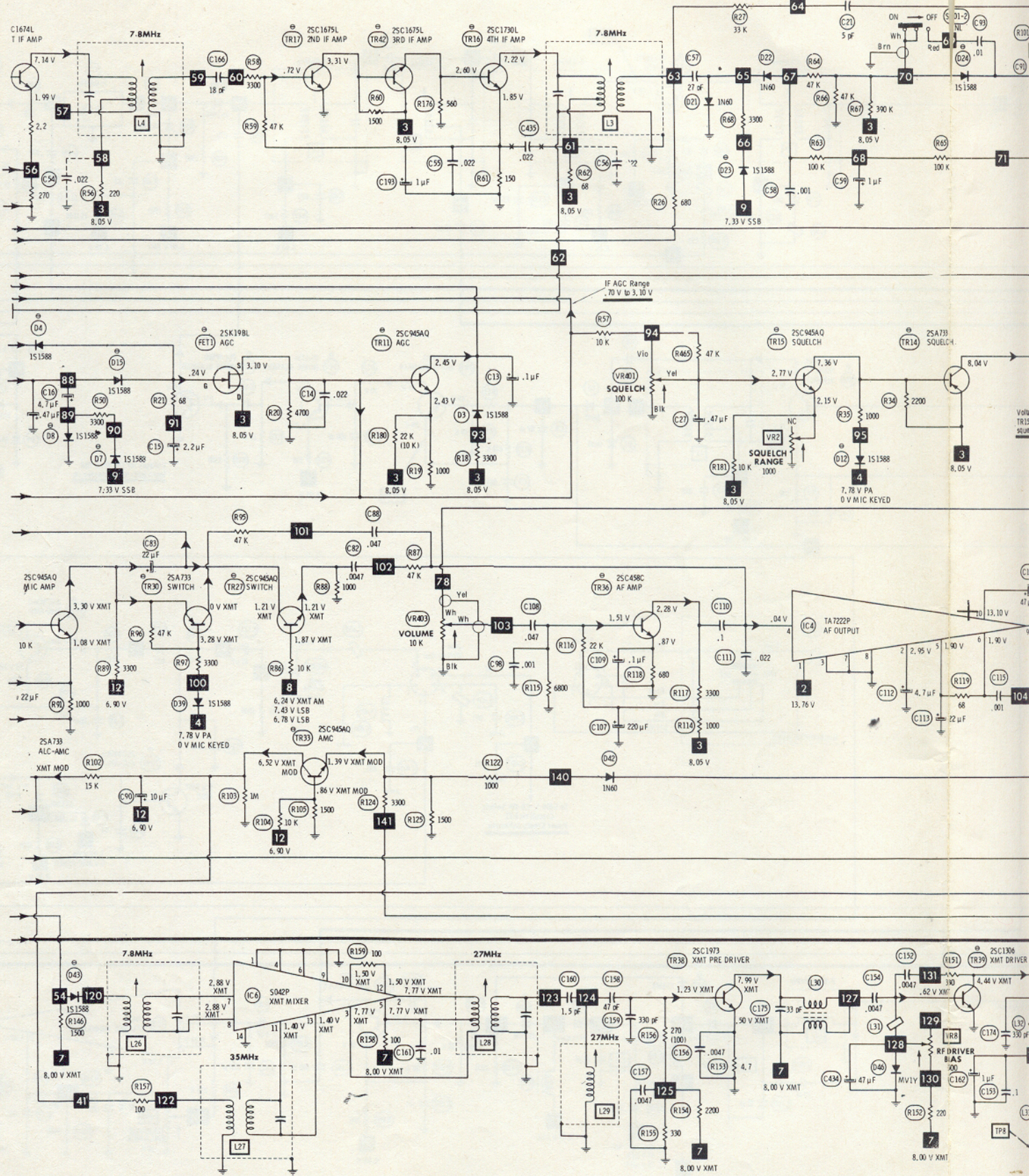

2 bis

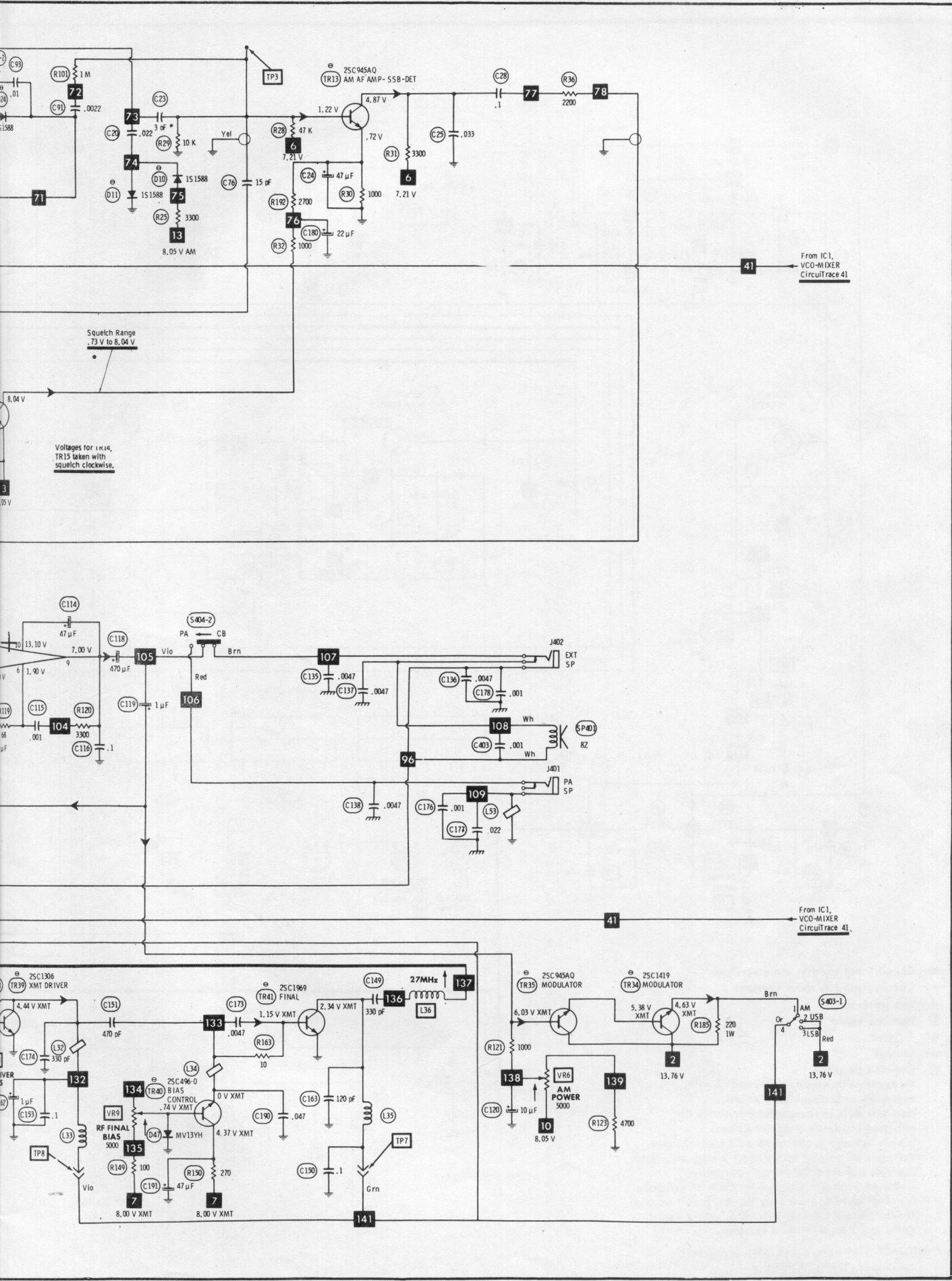

FUSE DEVICES

ITEM No.	DESCRIPTION	REPLACEMENT DATA						
		PART No.		BUSS PART No.		LITTELFUSE PART No.		WORKMAN PART No.
		DEVICE	HOLDER	DEVICE	HOLDER	DEVICE	HOLDER	DEVICE
F401	4 AMP		2700-001	AGC4	HDJ	311004	150145	

MICROPHONE

ITEM No.	REPLACEMENT DATA				CONNECTION DATA						
	MFGR. PART No.	GC PART No.	GC NOISE CANCEL	GC POWER	GC CONNECTOR	GC Red	GC Shield	GC Yellow	GC Blue	GC White	GC Black
Mic	3200-004	18-032	18-034	18-010		1	2	5	3	NC	4

MISCELLANEOUS

ITEM No.	PART NAME	PART No.	NOTES
D401	LED	2000-306	Channel Display TLR321
D402	LED	2000-343	TX/RX (2.07V @ 15mA) TLRG101
FL1	Filter	2200-306	7.8MHz
J401	Jack	1100-021	PA
J402	Jack	1100-021	External Speaker
J403	Jack	1100-003	Power
J404	Jack	1100-022	Microphone
J405	Jack	1100-018	Antenna
L31	Ferrite Bead	2200-052	LD-087
L32	Ferrite Bead	2200-108	LD101-1
L34	Ferrite Bead	2200-052	LD-087
L50	Ferrite Bead	2200-103	LD077
L51	Ferrite Bead	2200-103	LD077
L52	Ferrite Bead	2200-103	LD077
L53	Ferrite Bead	2200-103	LD077
L404	Ferrite Bead	2200-103	LD077
L405	Ferrite Bead	2200-103	LD077
M401	Meter	2900-009	S/Rf
S401	Switch	3000-110	Channel Selector
S402	Switch		Power (Part of Volume Control)
S403	Switch	3000-111	AM/USB/LSB
S404	Switch	3000-008	CB/PA
S405	Switch	3000-008	NB/ANL
S406	Switch	3000-008	Dimmer
X1	Crystal	2100-001	10.240MHz
X2	Crystal	2100-010	7.8025MHz
X3	Crystal	2100-011	7.7975MHz
X4	Crystal	2100-012	11.1125MHz
	Printed Circuit Board	3500-026	Channel Selector Switch
	Printed Circuit Board	3500-027	Channel Display
	Printed Circuit Board	3500-028	Push Switch
	Printed Circuit Board	3500-029	Microphone

CABINETS & CABINET PARTS (When ordering specify model, chassis & color)

ITEM	PART No.	ITEM	PART No.
Cabinet, Top	3300-116	Knob, Channel Selector	1300-001
Cabinet, Bottom	3300-117	Knob, Volume or RF Gain	1300-012
Mounting Bracket	3300-209	Knob, Squelch or Mike Gain	1300-011
Microphone Hanger	3300-401	Knob, Mode	1300-004
Escutcheon	3300-511	Knob, Clarifier	1300-002
Channel Display Window	3400-107	Knob, Push Switch	1300-003

