

((P))

PRICE \$ 2.50

# SERVICE MANUAL

PACE CB 166  
MOBILE TRANSCEIVER  
27 MHz CITIZENS BAND



**PATHCOM INC.**

PACE TWO-WAY RADIO PRODUCTS

24049 S. Frampton Ave., Harbor City, California 90710

L2073-276

**TABLE OF CONTENTS**

	Page
LIMITED WARRANTY . . . . .	ii
LIMITED 2-YEAR FACTORY SERVICE PROGRAM . . . . .	ii
LIST OF TABLES AND ILLUSTRATIONS . . . . .	iv
<b>SECTION</b>	
I. GENERAL INFORMATION . . . . .	1-1
GENERAL DESCRIPTION . . . . .	1-1
SPECIFICATIONS . . . . .	1-1
II. INSTALLATION PROCEDURES . . . . .	2-1
GENERAL . . . . .	2-1
MOUNTING SUGGESTIONS . . . . .	2-1
INSTALLATION INSTRUCTIONS . . . . .	2-3
ANTENNA AND CABLING CONNECTIONS . . . . .	2-3
III. PRINCIPLES OF OPERATION . . . . .	3-1
GENERAL . . . . .	3-1
OVERALL SYSTEM OPERATION . . . . .	3-1
DIGITAL SYNTHESIZER . . . . .	3-1
RECEIVER . . . . .	3-7
TRANSMITTER . . . . .	3-8
ANTENNA AND POWER SWITCHING . . . . .	3-9
IV. MAINTENANCE PROCEDURES . . . . .	4-1
GENERAL . . . . .	4-1
PREVENTIVE MAINTENANCE . . . . .	4-1
CORRECTIVE MAINTENANCE . . . . .	4-1
TROUBLESHOOTING . . . . .	4-1
FREQUENCY CHECK . . . . .	4-5
LOGIC CHECK OF PROGRAM SWITCH . . . . .	4-6
MODULATION CHECK . . . . .	4-7
V. ADJUSTMENT AND ALIGNMENT . . . . .	5-1
GENERAL . . . . .	5-1
TEST EQUIPMENT . . . . .	5-1
PRELIMINARY SETUP . . . . .	5-1
VCO ADJUSTMENT . . . . .	5-1
TRANSMITTER ALIGNMENT . . . . .	5-2
RECEIVER ALIGNMENT . . . . .	5-4
VI. ILLUSTRATIONS AND PARTS LIST . . . . .	6-1
GENERAL . . . . .	6-1

## LIST OF TABLES

Table	Page
1-1. TECHNICAL SPECIFICATIONS . . . . .	1-1
4-1. TEST EQUIPMENT REQUIRED . . . . .	4-2
4-2. RECEIVER VOLTAGE CHART . . . . .	4-3
4-3. TRANSMITTER VOLTAGE CHART . . . . .	4-4
4-4. SYNTHESIZER AND OSCILLATOR VOLTAGE CHART . . . . .	4-4
4-5. VCO FREQUENCIES . . . . .	4-5
4-6. PROGRAM SWITCH TRUTH TABLE . . . . .	4-6
6-1. PARTS LIST . . . . .	6-1
A-1. INTEGRATED CIRCUIT CROSS-REFERENCE . . . . .	A-1

## LIST OF ILLUSTRATIONS

Figure	
2-1. MOUNTING INSTRUCTIONS . . . . .	2-2
2-2. SUGGESTED MOUNTING POSITIONS FOR BASE STATION INSTALLATION . . . . .	2-3
2-3. CONNECTOR LOCATIONS . . . . .	2-4
3-1. CB 166 BLOCK DIAGRAM . . . . .	3-2
3-2. BASIC PLL SYSTEM USED IN CB 166 . . . . .	3-3
3-3. VCO CIRCUIT . . . . .	3-3
3-4. BINARY COUNTER . . . . .	3-4
3-5. REFERENCE OSCILLATOR CIRCUIT . . . . .	3-5
3-6. OUT-OF-LOCK CIRCUITRY . . . . .	3-6
3-7. PHASE DETECTOR CIRCUIT . . . . .	3-6
3-8. AGC CIRCUIT . . . . .	3-7
3-9. ANTENNA AND POWER SWITCHING . . . . .	3-9
4-1. RF PROBE . . . . .	4-2
4-2. MODULATION DETECTOR . . . . .	4-7
4-3. DIRECT MODULATION MONITOR . . . . .	4-8
5-1. PLL AND TRANSMITTER ADJUSTMENT LOCATIONS . . . . .	5-3
5-2. RECEIVER ADJUSTMENT LOCATIONS . . . . .	5-5
6-1. PARTS LOCATOR . . . . .	6-4
6-2. SCHEMATIC . . . . .	6-4
PHASE-FREQUENCY DETECTOR . . . . .	A-2
QUADRUPLE 2-INPUT NAND GATE . . . . .	A-3
DUAL 4-INPUT NAND BUFFER . . . . .	A-4
DUAL D TYPE EDGE TRIGGERED FLIP-FLOP . . . . .	A-5
4-BIT BINARY COUNTER . . . . .	A-6
SYNCHRONOUS 4-BIT COUNTER . . . . .	A-7

**SECTION I**

**GENERAL INFORMATION**

**1.1 GENERAL DESCRIPTION**

This manual contains installation, service, and maintenance information for the PACE Model CB 166 Mobile Transceiver manufactured by PATHCOM INC. It also includes a circuit description and all necessary information required to perform a troubleshooting analysis and a complete alignment of the PACE Model CB 166.

Twenty-three channel CB operation is made possible with only one crystal using digital integrated circuit modules in a phase-locked loop circuit.

**1.2 SPECIFICATIONS**

Technical specifications for the PACE CB 166 Mobile Transceiver is shown in Table 1-1.

**Table 1-1  
Technical Specifications**

<b>GENERAL</b>	
Number of Channels . . . . .	23
Operating Voltage . . . . .	12 V nominal DC $\pm$ ground
Frequency Range . . . . .	26.965 to 27.255 MHz
Microphone . . . . .	Dynamic, with plug-in connector
Speaker . . . . .	3" round dynamic, 8 $\Omega$
Antenna Impedance . . . . .	50 $\Omega$
Size . . . . .	Approximately 6-5/8" x 1-7/8" x 9"
Weight . . . . .	Approximately 4 lbs. (with accessories)
<b>RECEIVER</b>	
Sensitivity . . . . .	0.5 $\mu$ V for 10 dB $\frac{s+n}{n}$
Adjacent Channel Rejection . . . . .	50 dB minimum
Spurious Rejection (Major Image) . . . . .	50 dB minimum
Squelch Sensitivity (Threshold) . . . . .	1 $\mu$ V minimum
Audio Output . . . . .	2 W
<b>TRANSMITTER</b>	
Compliance . . . . .	FCC Type Number 42227, Part 95
Power Output . . . . .	4 W (maximum legal power)
Modulation . . . . .	85% minimum guaranteed sine wave (typically 95%)
Harmonic Suppression (TV Interference) . . . . .	50 dB
All specifications subject to change without notice.	

**NOTES**

## SECTION II INSTALLATION PROCEDURES

### 2.1 GENERAL

This section contains installation instructions for the PACE Model CB 166 Mobile Transceiver,

To those readily familiar with transistorized CB radio equipment, there is a tendency to install and operate the equipment without reading the details in the instruction manual. To avoid disappointment and improper performance, a thorough study of this manual is recommended. In particular, the following precautionary notes should be strictly observed.

*Do not* attempt transmitter adjustments or alignment unless you hold a valid first- or second-class FCC Radiotelephone License.

*Do not* attempt to connect the power cord to a primary source with the power switch on. Determine system polarity before connection. The CB 166 is wired for positive or negative ground systems. The red lead is (+) positive. The black lead is (-) negative.

*Do not* connect the antenna with the power on.

*Do not* key the transmitter without an antenna connected.

*Do not* replace the fuse with any other type than originally supplied with the transceiver.

*Do not* attempt alignment of the transmitter to the antenna. Loss of modulation power and inefficient operation (possibly resulting in transistor burnout) may occur unless the factory prescribed tuning procedure is followed. Maximum efficiency of an installation can only be accomplished when the antenna has a VSWR of less than 1.5:1. The antenna should be tuned, trimmed, or replaced, if necessary, to achieve this.

### 2.2 MOUNTING SUGGESTIONS

The Model CB 166 Transceiver can be mounted in any position without affecting its performance. The desired method and location of mounting should be determined before attempting the installation.

When selecting the mounting position, keep the following in mind:

1. The controls must be convenient and visible.
2. The location should not interfere with the driver or operator's normal functions.
3. The transceiver should not be mounted in the way of heater ducts, air-conditioning outlets, or direct blast air inlets.
4. The transceiver should be protected from rain and spray.

### 2.2.1 Under Dashboard Mount

The ideal location in a mobile unit is directly under the dashboard. A mounting bracket and hardware are provided for this purpose. Mounting instructions are shown in Figure 2-1.

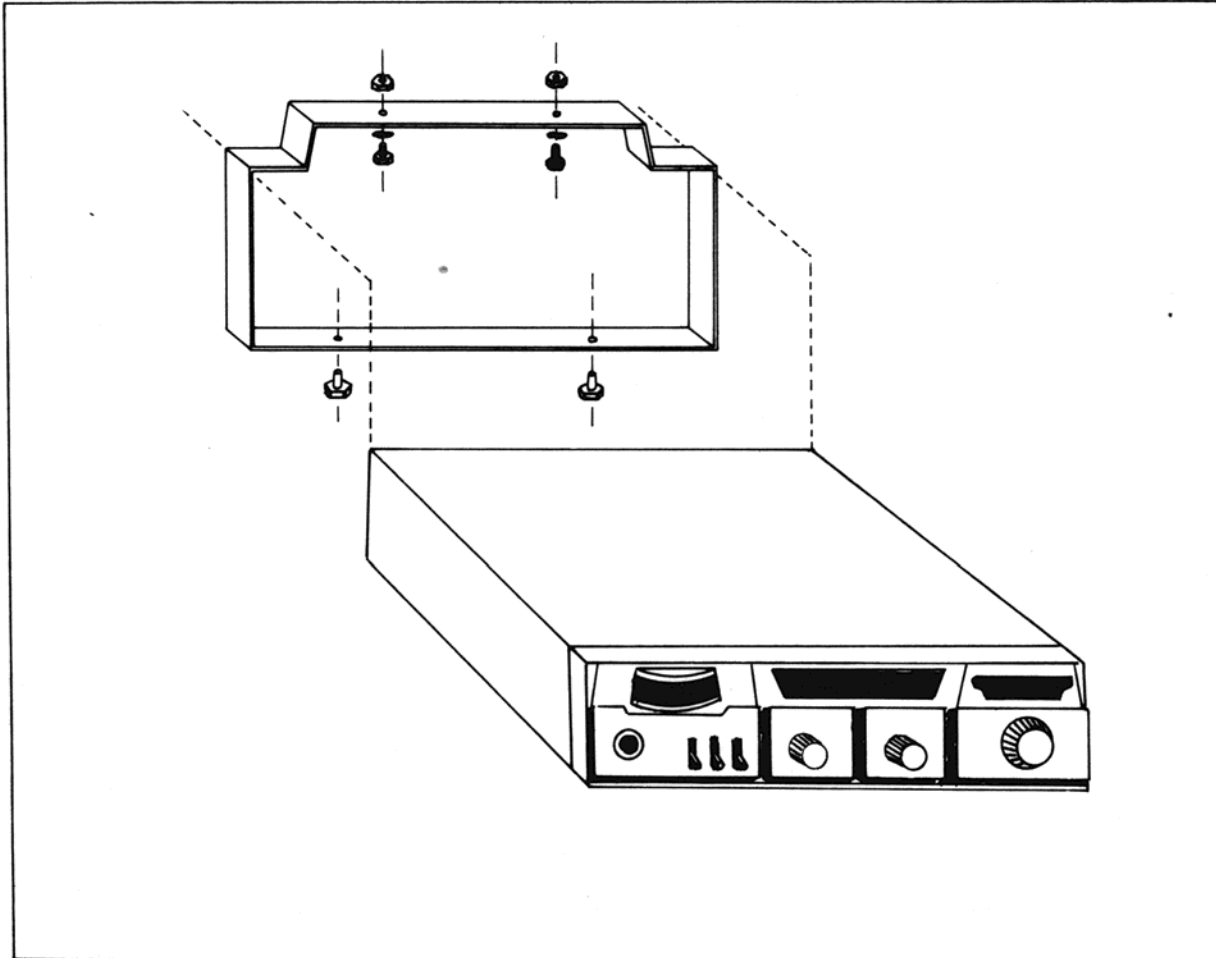

Figure 2-1 Mounting Instructions

### 2.2.2 Base Station Mount

When used as a base station (with appropriate power supply), the unit may be placed on a desk or permanently located in one of the positions shown in Figure 2-2, using the bracket and hardware.

#### NOTE

*If no external speaker is used, be sure the internal speaker is not mounted against a flat surface, as this will block the sound.*

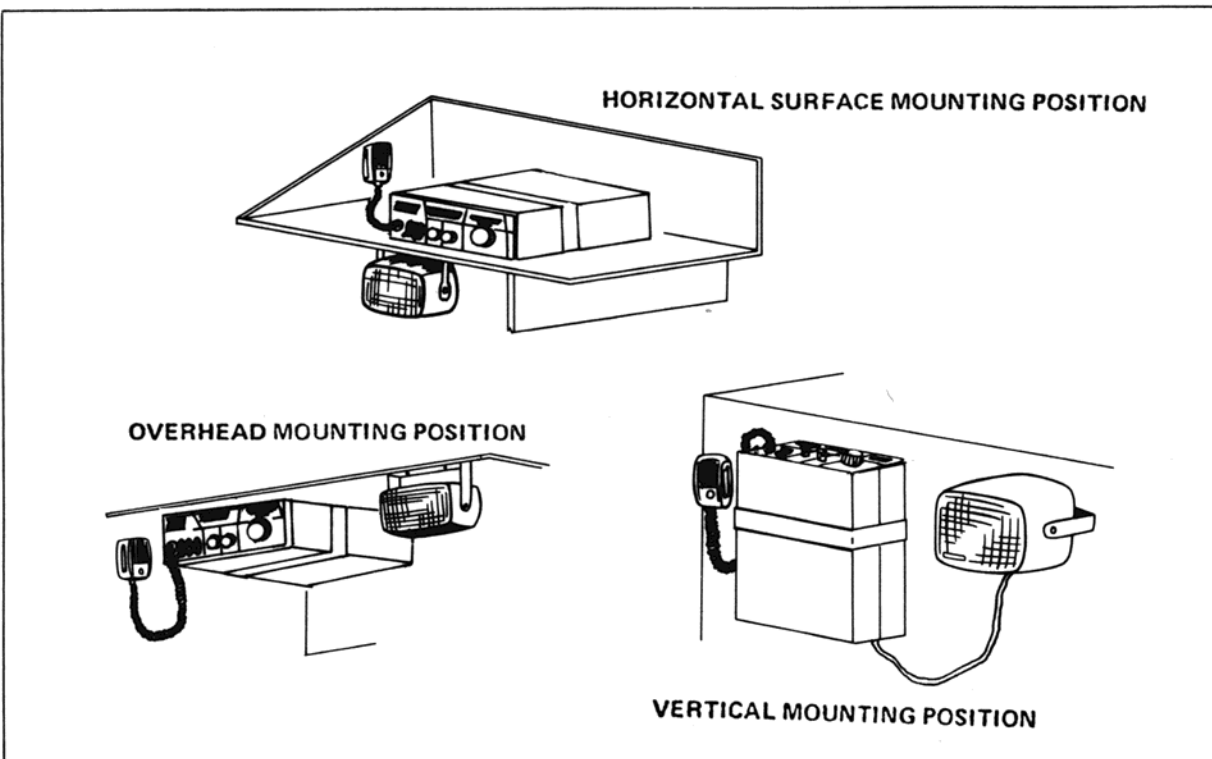

Figure 2-2 Suggested Mounting Positions for Base Station Installation

## 2.3 INSTALLATION INSTRUCTIONS

### 2.3.1 Transceiver Installation

As described in Section 2.2, the transceiver may be mounted in any desired position. Positioning of the microphone should be taken into consideration. As a general rule, the transceiver should be at least three feet from the antenna to prevent RF feedback.

## 2.4 ANTENNA AND CABLING CONNECTIONS

All connections to the CB 166 except for the microphone, are made through connectors located on the rear panel. Refer to Figure 2-3 for connector locations.

### 2.4.1 Antenna Installation

For runs of over 20 feet, use RG 8/U antenna transmission line. RG 58/U may be used for 20 feet or less. Connect the antenna to the coaxial cable connector located on the rear panel (see Figure 2-3).

The length of the cable from the antenna to the radio is, contrary to popular belief, not important. What is important is that the antenna have low VSWR. If a shortened type of antenna is used, it is mandatory that the VSWR be checked. A *Bird 43* VSWR bridge (or a similar type instrument) can be used. If the VSWR is greater than 1.5:1, the antenna must be adjusted in accordance with the manufacturer's instructions. If the antenna is a 1/4 wave nonadjustable type, the cable connections and the ground at the antenna mount should be checked.



Do not attempt VSWR checks if the vehicle is parked closer than 35 feet from a large fence, metal building, etc.

### 2.4.2 Power Connections

The transceiver is designed to operate from a nominal 12 volt DC source. This unit may be installed in vehicles which have either positive or negative ground. Since all passenger vehicles and most trucks use 12 volt negative ground systems, the power line is filtered for best noise limiting under negative ground installations, with the fuse in the red (+) line.

#### NOTE

*When installing in 12 volt positive ground systems, the red lead is still connected to the positive terminal and the black lead to the negative terminal. This means your grounded lead is fused, which will still give you the same over-current protection.*

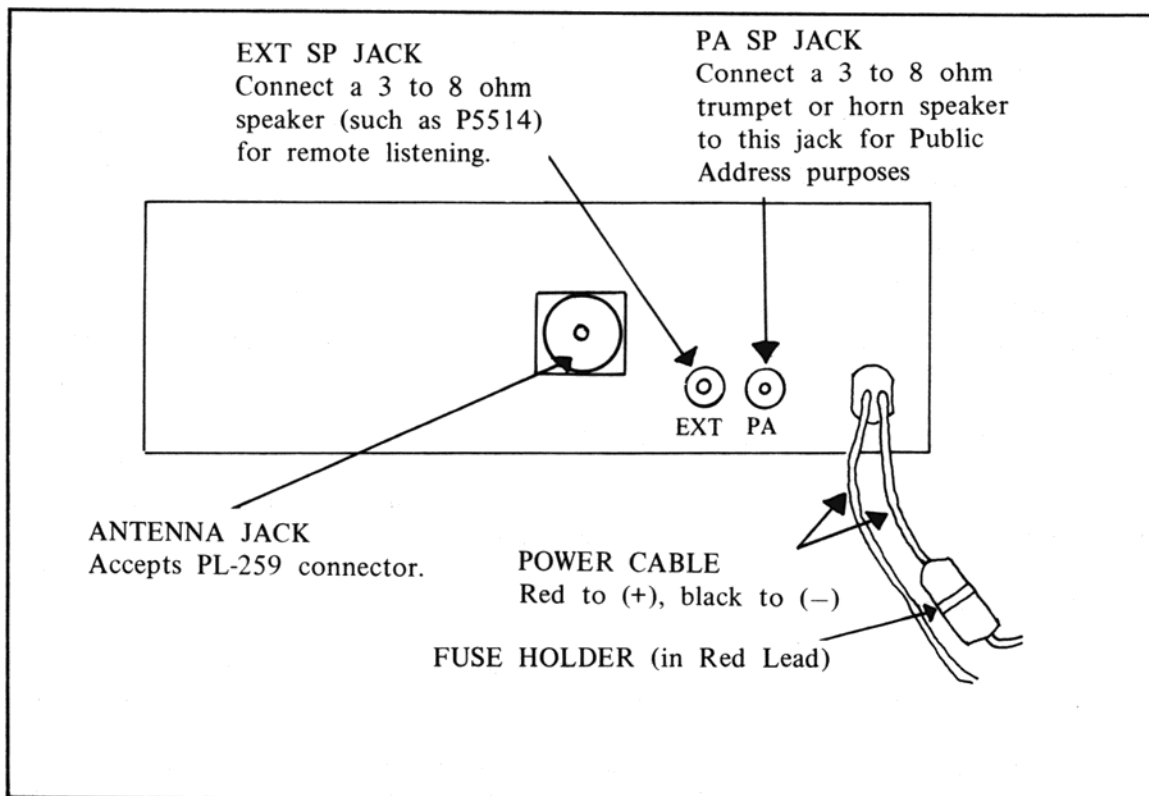

Figure 2-3 Connector Locations

The transceiver will operate over the nominal input voltage range of 10–16 volts continuous operation. Performance varies according to voltage levels, so care should be made in insuring that a level of 13.8 volts is maintained, which is the designed voltage level of this unit for maximum proper performance.

Connect the power cord to a well regulated source, such as an ammeter terminal or ignition switch. With this method, the transceiver is only operational when the ignition switch is on. Thus, any unauthorized person is prevented from operating your unit. “Tapping off” of dome or “courtesy” light wires is not recommended as these circuits are usually wired very lightly and some power loss would be encountered. Always install the black wire between the radio chassis and vehicle chassis or system ground to reduce noise pickup.

### 2.4.3 Speaker Installation

#### CAUTION

*The speaker used must be isolated from ground. Two leads are required from speaker to jack. Use proper speaker plug that does not make contact with rear panel.*

#### A. EXTERNAL SPEAKER CONNECTION

The EXT SPKR jack functions in the CB position and can be used to operate an external speaker for receiving purposes. Any suitable speaker of 3 to 8 ohms is satisfactory. The PACE P5514 has been especially designed to overcome vehicle and engine noise in this type of application, and is also weather-resistant. Its acoustic output is much greater than that of normal internal speakers.

#### NOTE

*The P5514 comes equipped with a phono plug on the end. An adapter must be used for the miniature phone jack on the transceiver.*

#### B. PUBLIC ADDRESS (P.A.) SPEAKER CONNECTION

A trumpet or horn speaker of 3 to 8 ohms impedance is desirable for this purpose. Connect the speaker to a suitable length of cable using a standard miniature phone plug. The miniature phone plug is inserted in the P.A. jack.

**NOTES**

**SECTION III  
PRINCIPLES OF OPERATION****3.1 GENERAL**

This section provides a general description of the PACE CB 166 operating principles. Overall system operation and major circuits are described.

**3.2 OVERALL SYSTEM OPERATION**

Figure 3-1 is a block diagram of the CB 166 and illustrates overall system operation. The radio receiver and transmitter share the same antenna and use a common Phase-Locked Loop (PLL) digital synthesizer. Transmit and receive frequencies are derived for 23 channels with the use of a single crystal.

Receiver IF frequency is obtained by a dual-conversion process. The PLL voltage controlled oscillator (VCO) is mixed with the incoming signal to produce a 1st-IF of 10.695 MHz. The 1st-IF is then mixed with 10.240 MHz from the reference oscillator (in the synthesizer) to produce the 2nd-IF of 455 kHz. This is amplified and filtered in a 2-stage IF amplifier. The audio signal is then detected, after which it is amplified and fed to a loudspeaker.

The transmitter frequency is derived by mixing the outputs of the VCO and the reference oscillator. The 27 MHz output goes through a bandpass amplifier and is then fed to the driver and final amplifier where it is modulated and coupled to the antenna.

**3.3 DIGITAL SYNTHESIZER**

This part describes the PLL oscillator and digital synthesizer circuits which are common to the transmitter and receiver circuits.

**3.3.1 The Basic PLL Circuit**

The basic PLL circuit used in the CB 166 is illustrated in the block diagram of Figure 3-2. The PLL circuit is a feedback system which consists of a phase detector, low pass filter, a programmable divider, and a VCO. The output from the programmable divider is fed to the phase detector where it is compared with a 10 kHz signal derived from the reference oscillator.

When the channel selector switch is set for a particular frequency, the divider is programmed to divide the VCO output by a value of N which will produce 10 kHz. If the VCO is off frequency, the phase detector will produce an error correction voltage which is fed back to the VCO. This completes the loop and causes the frequency of the VCO to more closely approach the desired frequency. The VCO continues to change frequency until its output locks in on the desired frequency.

**3.3.2 Voltage-Controlled Oscillator (Figure 3-3)**

The VCO consists of transistor Q18 and associated components. This is a free-running oscillator whose frequency is determined by CR27 and L5. CR27 is a voltage variable capacitor and is controlled by the correction voltage from the phase-locked loop. The output from Q18 is coupled to buffer Q19 and onto VCO output Q20. The output from Q20 is then fed to the first receiver mixer Q2 via C320, and to the transmitter mixer Q21 via C322.

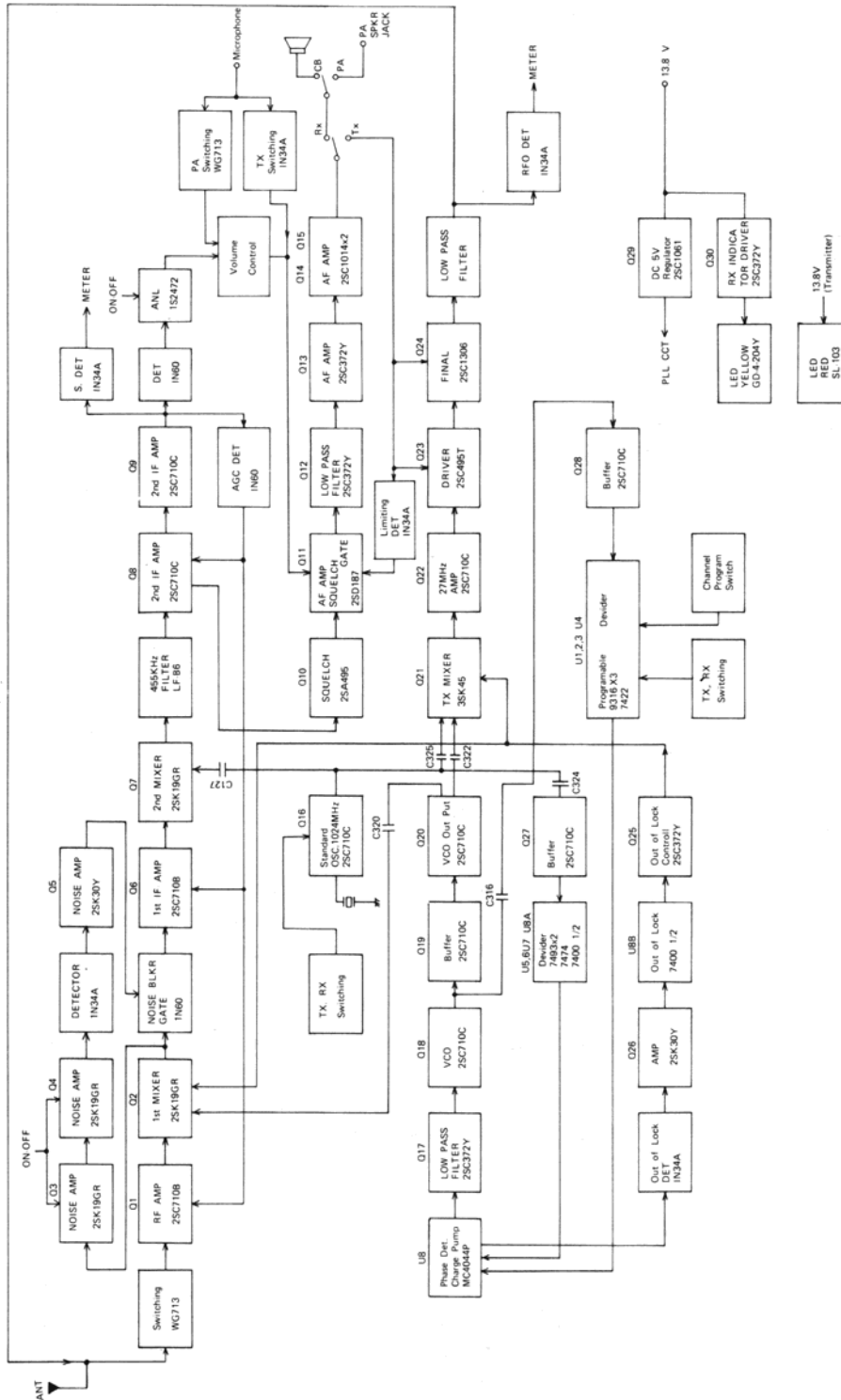

Figure 3-1 CB 166 Block Diagram

**3.3.3 Programmable Divider**

IC's U1 through U4 form a synchronous 4-bit binary counter. Its function is to divide the frequency output (from the VCO) down to 10 kHz for comparison with 10 kHz from the reference oscillator. See Figure 3-2. The division factor N is preset by the setting of the channel program switch. Thus, N has a different value for each channel selected (N may go as high as 4,095). For example, when Channel 1 is selected, the desired receiver output frequency from the VCO is 16.270 MHz, and the value of N selected is 1627. For Channel 23, the VCO receiver frequency is 16.730 MHz and N is 1673.

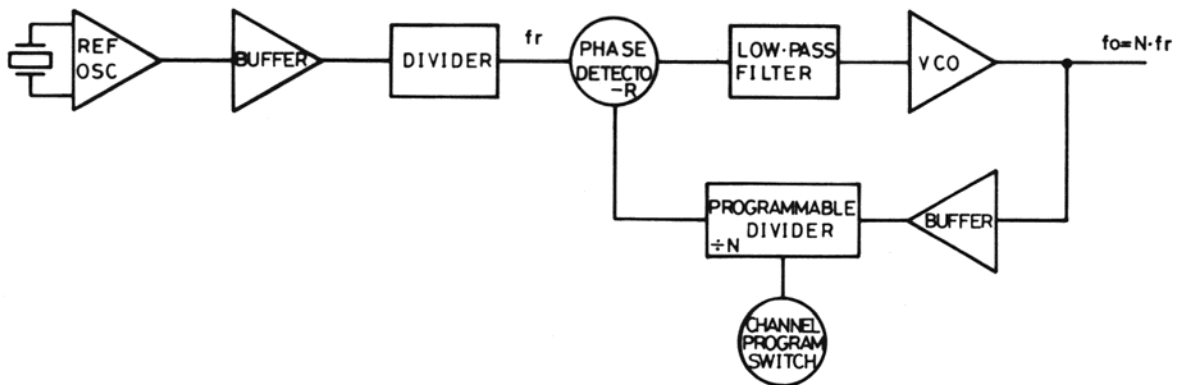

Figure 3-2 Basic PLL System Used in CB 166

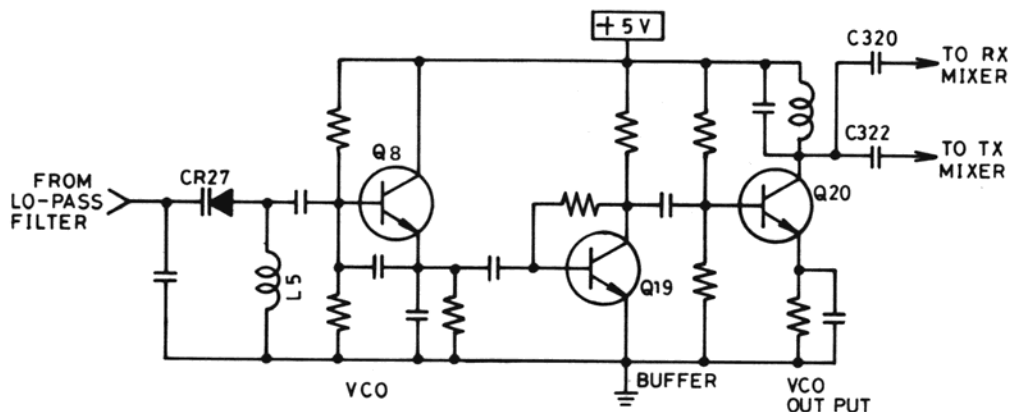

Figure 3-3 VCO Circuit

U4 is a dual 4-input NAND gate. It is used to reset the binary counter to start counting again. Refer to Figure 3-4. When the appropriate signals have been applied to the inputs of the gates, a short duration pulse is applied to the  $\overline{PE}$  terminals of U1, U2, and U3 to achieve this, each time a counting cycle has been completed.

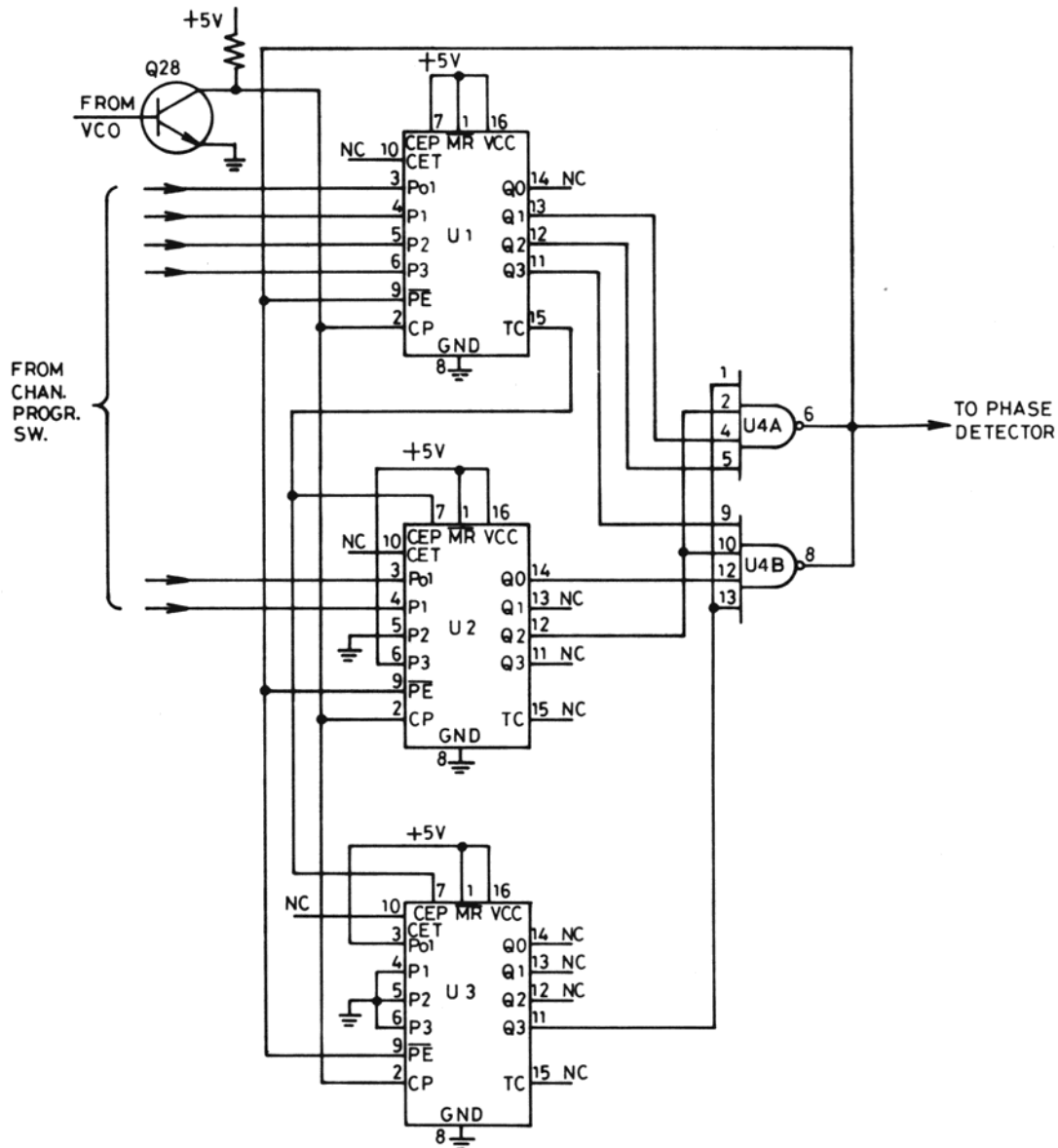

Figure 3-4 Binary Counter

### 3.3.4 Reference Oscillator

Reference Oscillator Q16 and associated circuitry performs three functions:

- (a) It acts as the second local oscillator in receive mode.
- (b) It is mixed with the VCO output in the transmitter mixer to provide the channel frequency.
- (c) After division, it provides the reference frequency,  $f_r$ , for the PLL circuit.

This is a crystal controlled oscillator, whose basic frequency is 10.240 MHz in the receive mode. In the transmit mode, CR26 is forward biased, inserting L4, R305, R306, and C306 into the circuit. This shifts the frequency down to 10.238 MHz.

The output from Q16 is taken from its emitter, and is coupled to the various circuits listed as shown in Figure 3-5.

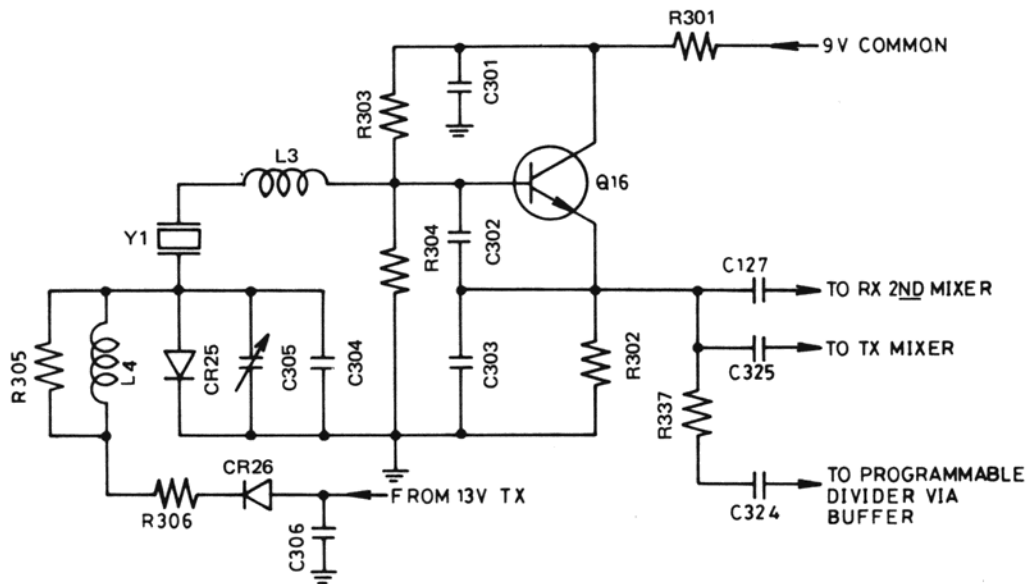

Figure 3-5 Reference Oscillator Circuit

### 3.3.5 Out of Lock Circuitry

As was previously described, the VCO is a free-running oscillator until it is locked in by the PLL circuit. When switching to another channel, noise may be heard in the receiver until the frequency is locked in. The out-of-lock circuitry has been added to prevent this. Refer to Figure 3-6.



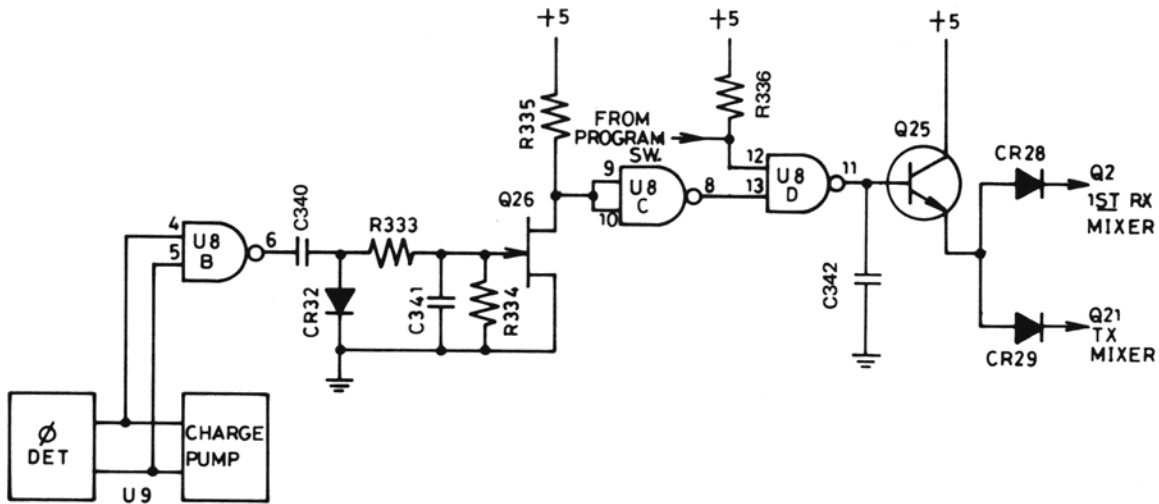

Figure 3-6 Out-of-Lock Circuitry

Under out-of-lock conditions a difference frequency appears at the output of U8 Gate B. This is rectified by CR32 so that a negative bias is applied to Q26 cutting that transistor off. Consequently, Q25 is biased into saturation, so that diodes CR28 and CR29 are forward biased. Positive voltages are then applied to the sources of RX mixer Q2 and TX mixer Q21, cutting them off.

**3.3.6 Phase Detector (Figure 3-7)**

The output pulse from the programmable divider is compared with a 10 kHz pulse from the reference oscillator in U9-A. Charge pump, U9-B, translates any phase difference into a DC bias voltage which is fed to the voltage variable capacitor, CR27, in the VCO. Thus, it either pumps the frequency up if too low, or down if too high. No correction voltage is supplied if there is no phase difference, and the frequency is locked in.

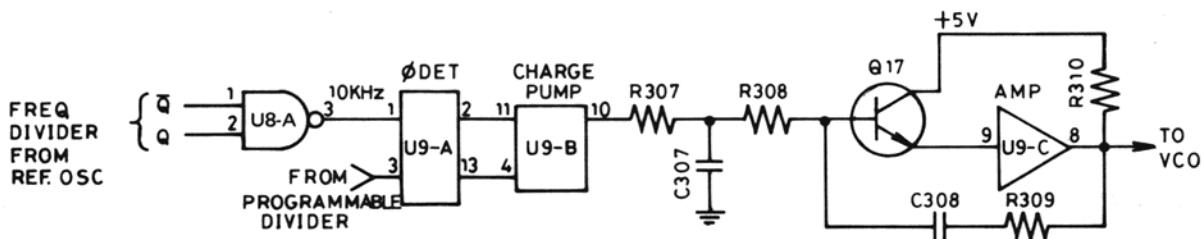

Figure 3-7 Phase Detector Circuit

## 3.4 RECEIVER (REFER TO SCHEMATIC IN SECTION VI)

### 3.4.1 RF and IF Circuits

The incoming RF signal is fed from the antenna to RF amplifier Q1 via antenna matching network (C423, L16, and C420) and transformer T1. After amplification, the RF signal is coupled through T2 to the gate of mixer Q2. The VCO frequency is injected into the source of Q2 via C320 which results in a frequency of 10.695 MHz at the drain. This 1st-IF is coupled through noise blanker gate diode CR8 to the 1st-IF amplifier Q6 and then fed to 2nd mixer Q7. A frequency of 10.240 MHz from the reference oscillator is injected into the gate of Q7 via C127. These frequencies are mixed in Q7 to produce a 2nd-IF of 455 kHz. Ceramic filter, LF-B6, eliminates any unwanted signals and passes only the desired signal. This frequency is then amplified in the 2-stage 2nd-IF amplifier Q8 and Q9.

### 3.4.2 Detector and Automatic Noise Limiter (ANL)

After amplification, the 455 kHz signal is fed to detector diodes CR9 and CR10 via C138. The detected audio signal then passes through ANL diode CR14 to volume control R158.

When there are no noise pulses present in the signal, ANL noise diode CR14 is forward biased due to the charge on C140, and the signal is permitted to pass. When a noise pulse is present CR14 becomes reverse biased due to the time constant of C140 and R133. The noise pulse is then blocked from passing through to the audio amplifier.

### 3.4.3 Automatic Gain Control (AGC)

Under static conditions (no signal) a positive voltage, supplied through R154, is present on the AGC line. See Figure 3-8. When a signal is received, a negative voltage is produced by rectifier diodes CR11 and CR12. The negative voltage corresponds to the level of the received signal. This decreases the bias applied to Q1, Q6, and Q8 to prevent saturation of these stages when a strong signal is received.

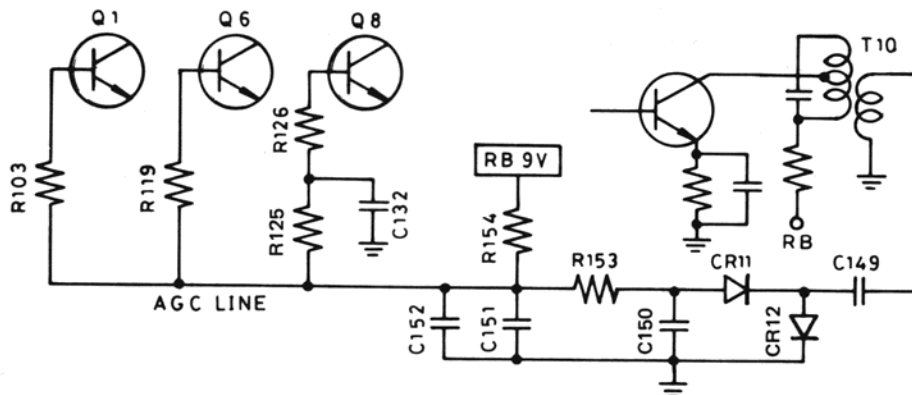

Figure 3-8 AGC Circuit

#### **3.4.4 Squelch**

When a strong signal is received, AGC voltage to Q8 is lowered and the collector current is decreased. The increased voltage from the collector of Q8 is fed through R156 and squelch control R157 to the base of squelch gate Q10 which is a PNP transistor. This causes Q10 to cut off so that its collector goes down. The emitter of 1st audio amplifier Q11 goes down so that it operates at the normal level. R156 is adjusted for tight squelch sensitivity.

#### **3.4.5 Audio Amplifier**

After amplification in Q11, the audio is fed to active low-pass filter Q12 and then to audio driver Q13. The audio power amplifier, Q14 and Q15, increases the audio power sufficiently to drive the 8 ohm speaker.

#### **3.4.6 "S" Meter**

CR13, connected to the secondary of T10, produces a positive rectified voltage whose amplitude corresponds to the level of the incoming signal. This is fed through R155 to the "S" meter. R155 is adjusted for a reading of 9 "S" units, on the meter, with an input signal of 100  $\mu$ V.

#### **3.4.7 Noise Blanker Circuit**

A portion of the IF signal (including noise) is fed through C111 to noise amplifier Q3. T5 is tuned to 9.5 MHz to pass the noise component, while T6 is tuned to 10.695 MHz to block the intelligence component of the signal. The noise is amplified by Q4 and rectified by CR4 and CR5. Positive pulses cause Q5 to become forward biased so that it goes into conduction. This causes CR8 to become reverse biased so that impulse noises are blanked out and only the desired signal is permitted to pass.

### **3.5 TRANSMITTER**

#### **3.5.1 27 MHz Carrier Amplifier**

Transmitter mixer Q21 is a dual-gate MOSFET. This circuit provides maximum rejection of unwanted products. The VCO output is coupled to G2 while the output from reference oscillator Q16 is coupled to G1. Inductors L8 and L9 are tuned to 27 MHz to eliminate unwanted frequencies. The carrier signal is amplified by band-pass amplifier Q22, driver Q23, and final power amplifier Q24. The carrier is modulated in Q23 and Q24 and coupled to the antenna via harmonic filter L14, L15, L16, C419, C420, and C422.

#### **3.5.2 Modulator**

In transmit mode, the audio amplifier is used to provide modulation. When the P-T-T switch is pressed, CR16 is forward biased and provides a signal path for audio from the microphone. From CR16, the signal is fed to the base of audio amplifier Q11. Amplified audio from the secondary of T12 then modulates TX driver Q23 and TX power amplifier Q24.

### 3.5.3 Modulation Limiter

A portion of the modulation signal is picked up through C215 and rectified by diodes CR20 and CR21. The rectified negative voltage is filtered and applied to the base of audio amplifier Q11. The negative bias increases in proportion to the increase of percent modulation. This is done to prevent exceeding 100% modulation. R207 is adjusted for 100% modulation.

### 3.5.4 Power Meter Circuit

Power output signals are coupled through C424 to CR33 where it is rectified, and filtered by C425. This positive DC voltage is then fed to the meter via limiting potentiometer R413.

## 3.6 ANTENNA AND POWER SWITCHING

In the CB 166, antenna switching is accomplished by switching diode CR1, instead of relay switch contacts. This method eliminates the possibility of RF leakage through the switch.

In the normal (receive) mode (see Figure 3-9), +9 V is applied to the cathode of CR1 so that it is reverse biased and signals from the antenna are permitted to pass through T1 to the RF amplifier. No power is supplied to the TX mixer and bandpass amplifier; and, since the power output stage is Class C, this stage is cut off. Therefore, there are no TX antenna currents present that will affect the receiver.

When the P-T-T switch is pressed, the cathode of CR1 is grounded, forcing it into conduction. This shorts out the input to T1, effectively disconnecting the receiver RF amplifier from the antenna. At the same time, the +9 V is removed from the receiver circuits and +13.8 V applied to the transmitter circuits.

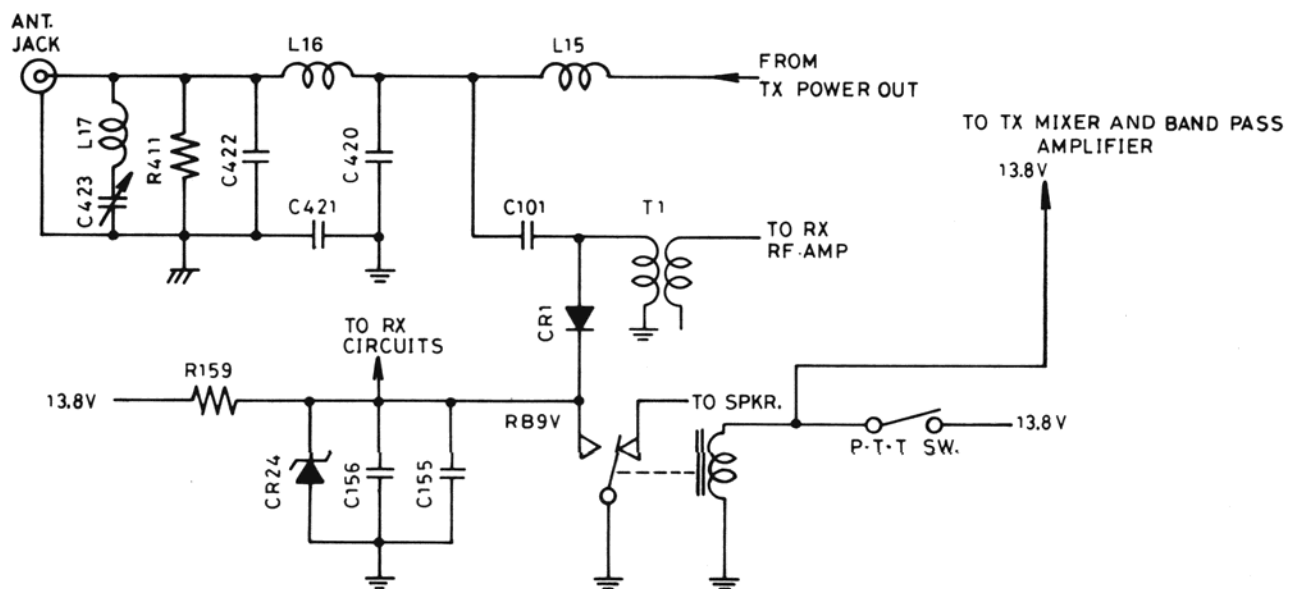

Figure 3-9 Antenna and Power Switching

**NOTES**

**SECTION IV  
MAINTENANCE PROCEDURES****4.1 GENERAL**

This section contains maintenance instructions for the PACE Model CB 166. The procedures given in this section assume a general knowledge of AM type communications transceivers and a familiarization with transistors and integrated circuits.

**4.1.1 Tools and Techniques**

A list of recommended tools and test equipment required for maintenance operations is presented in Table 4-1. Aside from the items listed, hand tools and equipment commonly used in the maintenance of electronic equipment are sufficient for maintenance operations.

It is recommended that maintenance adjustments and repairs be performed only by experienced personnel familiar with the equipment. In some cases, minor changes in voltage levels may be corrected by adjusting potentiometers located in the affected circuits. Standard practices in the electronic industry should be observed in checking and/or replacing system components.

**4.1.2 Parts Identification**

For PC board component location, refer to illustrations and schematics in Section VI.

**4.2 PREVENTIVE MAINTENANCE**

The receiver requires minimal maintenance due to the nonmechanical nature of the equipment. However, a preventive maintenance program consisting of electrical checks is recommended as an aid in obtaining maximum operating efficiency from the system.

**4.3 CORRECTIVE MAINTENANCE**

Corrective maintenance operations entail transceiver checks and adjustments which are not part of preventive maintenance procedures. Operational malfunctions which require corrective maintenance may usually be corrected by an adjustment or PC board replacement. If necessary to make repairs at the component level, such repairs should be made by maintenance technicians who are familiar with the equipment and electronic repair techniques. Refer to Section V for alignment and adjustment procedures.

**4.4 TROUBLESHOOTING**

It is recommended that a functional analysis approach be used to locate the cause of the transceiver malfunction. Troubleshooting can be simplified by reference to the schematic diagrams in Section VI. Integrated circuit information is provided in Appendix A to aid in troubleshooting the phase-locked loop synthesizer.

Standard troubleshooting procedures, such as signal injection and signal tracing, should be used in locating faulty circuits. Once the trouble has been isolated to a particular circuit, the defective component can be localized by voltage and resistance measurements. Refer to voltage charts in Tables 4-2 through 4-4. Tables 4-2 and 4-3 provide DC voltages for all transistors in receiver and transmitter. Separate voltages are given where squelched conditions apply. Synthesizer and oscillator voltages are shown in Table 4-4.

**Table 4-1**  
**Test Equipment Required**

ITEM	MODEL OR DESCRIPTION
Power Source . . . . .	Regulated 13.8 V DC Power Supply ( <i>Hewlett-Packard</i> Model 624B or equivalent)
Wattmeter . . . . .	50 $\Omega$ , 25 W ( <i>Bird Electronics</i> Model 43 or equivalent)
Audio Generator . . . . .	Frequency Range: 200 Hz to 5 kHz minimum
Frequency Counter . . . . .	DC to 30 MHz minimum ( <i>Hewlett-Packard</i> Model 4245L or equivalent)
Oscilloscope . . . . .	30 MHz bandpass or DC coupled scope with detector ( <i>Tektronix</i> Model 545B or equivalent)
Vacuum Tube Voltmeter . . . . .	1 mV to 50 V AC or more ( <i>Hewlett-Packard</i> Model 410B or equivalent)
RF Signal Generator . . . . .	Capable of tuning 455 kHz, 7.8 MHz and 27 MHz CB frequencies ( <i>Hewlett-Packard</i> Model 606B or equivalent)
DC Voltmeter (Multimeter) . . . . .	High impedance input ( <i>RCA</i> WV-98C or equivalent)
RF Probe* . . . . .	For use with multimeter

\*If no probe is available for the multimeter, one may be fabricated as shown in Figure 4-1.

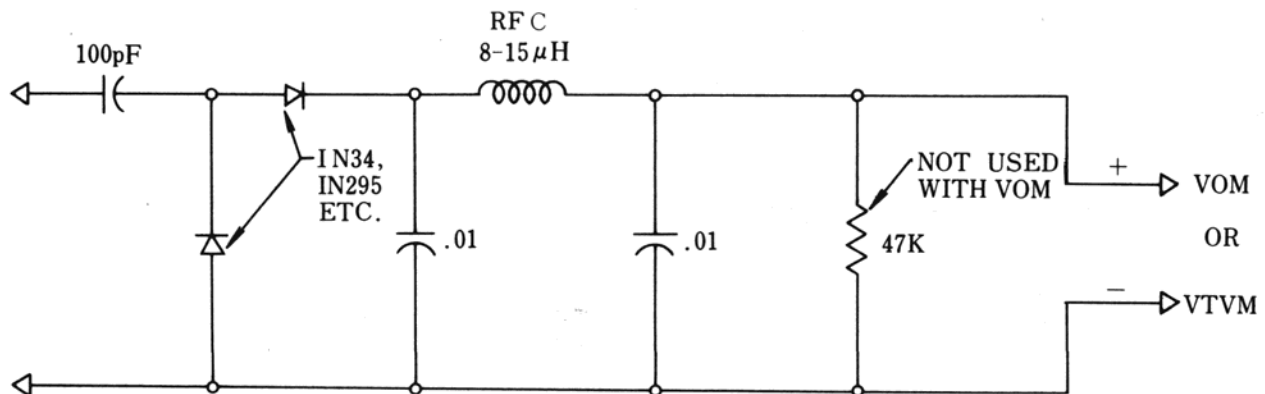

**Figure 4-1** RF Probe

Voltages were measured with an ohmmeter having a 20,000 ohm/volt sensitivity, with 13.8 V  $\pm$  5% DC input to the transceiver. All voltages are positive unless otherwise indicated, and have a tolerance of  $\pm$  20%.

Before proceeding with the troubleshooting procedures, the entire installation should be checked for defective antenna connections and loose or broken supply cables and plugs.

**Table 4-2**  
**Receiver Voltage Chart**

TRANSISTOR AND FUNCTION	TYPE	CONDITION	DC VOLTAGE VOLTS			
			EMITTER OR SOURCE	BASE OR GATE 1	GATE 2	COLLECTOR OR DRAIN
Q1 RF AMP.	NPN	RX MODE	0.7	1.3		8.2
		RX MODE	0.1	0.2		0
		PA MODE	0.75	1.35		8.2
Q2 1ST MIXER	FET	RX & PA MODES	2.7	0		8.5
		TX MODE	0	0		0
Q3 NOISE AMP.	FET	RX & PA MODES	1.6	0		8.5
		TX MODE	0	0		0
Q4 NOISE AMP.	FET	RX & PA MODES	0	0		8.9
		TX MODE	0	0		0
Q5 NOISE AMP.	FET	RX & PA MODES	0.3	0		4.9
		TX MODE	0	0		0
Q6 1ST-IF AMP.	NPN	RX & PA MODES	0.7	1.3		8.5
		TX MODE	0	0		0
Q7 2ND MIXER	FET	RX & PA MODES	2.5	0		8.5
		TX MODE	0	0		0
Q8 2ND-IF AMP.	NPN	RX MODE	0.7	1.3		6.0
		TX MODE	0	0		0
		PA MODE	2.0	1.3		8.0
Q9 2ND-IF AMP.	NPN	RX & PA MODES	1.4	2.0		7.0
		TX MODE	0	0		0
Q10 SQUELCH	PNP	RX & PA MODES SQ OFF	8.9	9.0		1.75
		TX MODE SQ OFF	0	0		0.6
		RX MODE SQ ON	8.9	8.1		8.8
		TX MODE SQ ON	0	0.2		0.8
		PA MODE SQ ON	8.9	8.1		2.6
		RX MODE SQ OFF	1.9	2.0		6.2
		TX MODE SQ OFF	1.7	1.7		1.3
Q11 SQUELCH GATE	NPN	PA MODE SQ OFF	1.9	1.85		1.55
		RX MODE SQ ON	3.5	2.0		8.9
		TX MODE SQ ON	1.7	1.7		1.35
		PA MODE SQ ON	1.9	1.85		1.7
		ALL MODES	3.0	3.5		9.0
Q12 LOW PASS FILTER	NPN	ALL MODES	0.9	1.5		12.2
Q13 AUDIO DRIVER	NPN	ALL MODES	0.05	0.7		13.8
Q14/Q15 AUDIO OUT.	NPN	ALL MODES	7.6	8.0		12.5
Q30 RX IND. DRIVER	NPN	RX & PA MODES	7.6	8.0		12.5
		TX MODE	0	0		13.0



**Table 4-3**  
**Transmitter Voltage Chart**

TRANSISTOR AND FUNCTION	TYPE	CONDITION	DC VOLTAGE VOLTS			
			EMITTER OR SOURCE	BASE OR GATE 1	GATE 2	COLLECTOR OR DRAIN
Q21 TX MIXER	DUAL-GATE FET	RX & PA MODES	0	0	0	0
		TX MODE	0.7	0	0	13.8
Q22 BAND PASS AMP.	NPN	RX & PA MODES	0	0		0
		TX MODE	1.0	1.7		12.0
Q23 TX DRIVER	NPN	RX & PA MODES	0	0		13.8
		TX MODE	0	0.1		13.8
Q24 TX FINAL	NPN	ALL MODES	0	0		13.8

**Table 4-4**  
**Synthesizer and Oscillator Voltage Chart**

TRANSISTOR AND FUNCTION	TYPE	CONDITION	DC VOLTAGE VOLTS			
			EMITTER OR SOURCE	BASE OR GATE 1	GATE 2	COLLECTOR OR DRAIN
Q16 REF. OSC.	NPN	ALL MODES	2.0	2.25		7.5
Q17 LOW PASS FILTER	NPN	ALL MODES	1.4	1.9		5.9
Q18 VCO	NPN	ALL MODES	1.2	1.5		5.1
Q19 BUFFER	NPN	ALL MODES	0	2.8		3.3
Q20 VCO OUTPUT	NPN	ALL MODES	0.65	1.2		5.1
Q25 OUT-OF-LOCK CONTROL	NPN	ALL MODES	0	0		5.1
		ON CHANNEL 22A	3.3	4.0		5.1
Q26 O-O-L AMP.	DUAL-GATE FET	ALL MODES	0	0	0	0.7
Q27 REF. OSC. BUFFER	NPN	ALL MODES	0	0.7		2.0
Q28 VCO BUFFER	NPN	ALL MODES	0	0.4		3.0
Q29 5 V DC REG.	NPN	ALL MODES	5.1	5.7		13.8

IC	DC VOLTAGE IN VOLTS*															
	PIN NUMBER															
	1	2	3	4	5	6	7	8	9	10	11	12	13	14	15	16
U1	5.1	2.5	0	5.0	5.0	5.0	5.1	0	5.1	1.5	1.8	1.8	1.8	1.6	0	0
U2	5.1	2.5	5.0	5.0	0	5.1	0	0	5.1	1.6	2.0	2.0	2.0	2.0	0.4	5.1
U3	5.1	2.5	5.1	0	0	0	0	0	5.1	0.4	0	2.5	2.5	2.0	0	5.1
U4	0	1.6	1.6	1.6	1.6	0	5.1	0	5.1	1.6	1.6	0	2.0	0		
U5	1.5	0	0	0	5.1	0	0	1.6	1.6	0	1.6	1.6	0	2.0		
U6	2.5	0	0	0	5.1	0	0	2.5	2.5	1.0	2.5	2.5	0	1.6		
U7	5.1	2.0	2.0	5.1	2.0	2.0	0	2.0	2.0	5.1	2.5	2.0	5.1	5.1		
U8	2.0	2.0	4.0	4.0	4.0	0	0	4.0	0.8	0.8	0	5.0	4.0	5.1		
U9	4.0	4.0	5.1	4.0	2.0	0	0	2.0	1.5	2.0	4.0	4.0	4.0	0		

\*All IC voltages were measured with the transceiver in RX mode on Channel 1.

**4.5 FREQUENCY CHECK**

Since the frequencies (RX and TX) for all channels are dependent upon the phase-locked loop synthesizer, off-frequency reception or transmission could be attributed to that circuit.

To check channel frequencies, connect a 50 ohm dummy load to the antenna jack. Then connect a frequency counter to the dummy load through an appropriate attenuator. The frequency for each channel should be within  $\pm 500$  Hz as shown in Column A of Table 4-5.

If any of the frequencies are off, both the reference oscillator and VCO frequency outputs should be checked. VCO frequencies for the various channels can be checked by moving the frequency counter to the source of 1st mixer Q2. Frequencies within  $\pm 500$  Hz of those shown in Column B should be measured. TX frequencies, shown in Column C, can be measured at gate 1 of TX mixer Q21.

**Table 4-5**  
**VCO Frequencies**

<b>CHANNEL</b>	<b>CHANNEL FREQUENCY IN MHz</b>	<b>RX VCO OUT FREQUENCY IN MHz</b>	<b>TX VCO OUT FREQUENCY IN MHz</b>
1	26.965	16.270	16.727
2	26.975	16.280	16.737
3	26.985	16.290	16.747
4	27.005	16.310	16.767
5	27.015	16.320	16.777
6	27.025	16.330	16.787
7	27.035	16.340	16.797
8	27.055	16.360	16.817
9	27.065	16.370	16.827
10	27.075	16.380	16.837
11	27.085	16.390	16.847
12	27.105	16.410	16.867
13	27.115	16.420	16.877
14	27.125	16.430	16.887
15	27.135	16.440	16.897
16	27.155	16.460	16.917
17	27.165	16.470	16.927
18	27.175	16.480	16.937
19	27.185	16.490	16.947
20	27.205	16.510	16.967
21	27.215	16.520	16.977
22	27.225	16.530	16.987
23	27.255	16.560	17.017

#### 4.6 LOGIC CHECK OF PROGRAM SWITCH

If the transmit or receive frequency does not correspond to that of the channel selected (on one of several channels), the cause is probably in the switching. A truth table of inputs to the programmable dividers for each channel in receive mode is given in Table 4-6. This will aid in locating the fault.

The following definitions apply to the truth table:

- (a) Logic "0" = Low = Less than 0.3 V (Switch Closed)
- (b) Logic "1" = High = More than 3.0 V (Switch Open)

Colors indicated at the heads of the columns correspond to the wire colors from the switch to the PC board. Therefore, measurements can be made at the switch contacts.

**Table 4-6**  
**Program Switch Truth Table**

COLOR	U3				U2				U1				GRN
	—	—	—	—	—	—	—	BLU	YEL	ORN	RED	BRN	
TERM	6	5	4	3	6	5	4	3	6	5	4	3	
CHAN	IN A	IN B	IN C	IN D	IN A	IN B	IN C	IN D	IN A	IN B	IN C	IN D	
1	0	0	0	1	1	0	1	1	1	1	1	0	1
2	0	0	0	1	1	0	1	1	1	1	0	1	1
3	0	0	0	1	1	0	1	1	1	1	0	0	1
4	0	0	0	1	1	0	1	1	1	0	1	0	1
5	0	0	0	1	1	0	1	1	1	0	0	1	1
6	0	0	0	1	1	0	1	1	1	0	0	0	1
7	0	0	0	1	1	0	1	1	0	1	1	1	1
8	0	0	0	1	1	0	1	1	0	1	0	1	1
9	0	0	0	1	1	0	1	1	0	1	0	0	1
10	0	0	0	1	1	0	1	1	0	0	1	1	1
11	0	0	0	1	1	0	1	1	0	0	1	0	1
12	0	0	0	1	1	0	1	1	0	0	0	0	1
13	0	0	0	1	1	0	1	0	1	1	1	1	1
14	0	0	0	1	1	0	1	0	1	1	1	0	1
15	0	0	0	1	1	0	1	0	1	1	0	1	1
16	0	0	0	1	1	0	1	0	1	0	1	1	1
17	0	0	0	1	1	0	1	0	1	0	1	0	1
18	0	0	0	1	1	0	1	0	1	0	0	1	1
19	0	0	0	1	1	0	1	0	1	0	0	0	1
20	0	0	0	1	1	0	1	0	0	1	1	0	1
21	0	0	0	1	1	0	1	0	0	1	0	1	1
22	0	0	0	1	1	0	1	0	0	1	0	0	1
X	0	0	0	1	1	0	1	0	0	0	0	1	0
23	0	0	0	1	1	0	1	0	0	0	0	1	1

## 4.7 MODULATION CHECK

There are three satisfactory methods of checking modulation:

1. A high frequency (30 MHz) oscilloscope, which can be directly coupled by a small capacitor to the antenna jack.
2. A low frequency scope with provisions for direct connection to the deflection plates. A twisted pair, with a 1½ turn link on the end, should be used for coupling. Connect the open end to the deflection plates and then orient the link near the power amplifier coils in the transceiver to obtain a deflection on the screen.
3. A linear detector and a DC oscilloscope would probably be the easiest method to use, and the most accurate, unless a high frequency oscilloscope is available. A suitable detector is shown in Figure 4-2A.

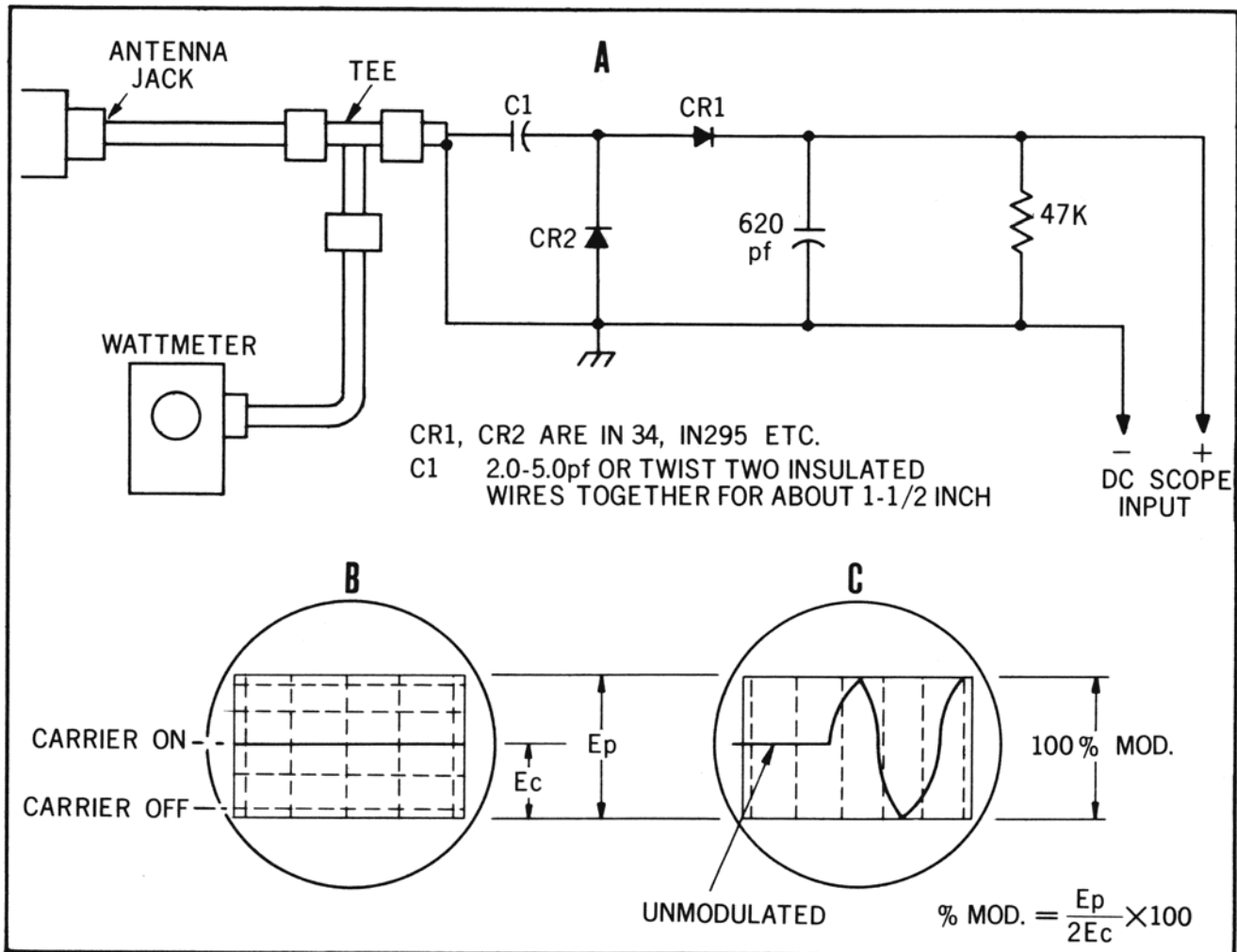

Figure 4-2 Modulation Detector

Inexpensive modulation indicators of the meter type have been found to be of irregular accuracy and of no value in checking for parasitics, etc., and, therefore, should not be relied upon.

If a high frequency scope is used, connect the probe to the antenna jack directly through a 20–50 pF capacitor. While transmitting a carrier only, adjust the gain to produce a pattern on the scope of about one-half the usable screen area.

Apply modulation and observe the maximum height of the modulated waveform. For 100% modulation,  $E_p = 2 E_m$ , etc. It is more important that the peak (positive going) portion be analyzed since the “trough” or negative going portion will always perform correctly when the peaks are present.

If a low frequency scope using a direct connection to the plates is employed, the same adjustment procedures apply.

To use the DC scope and detector of Figure 4-2A, adjust the position control with the carrier off to place the trace on a reference line near the bottom of the scope face. See Figure 4-2B. Then feed the unmodulated carrier to the detector and adjust the gain to place the trace in the center of the scope face. It may be necessary to switch the transmitter off and on several times to adjust the trace properly, since on most scopes the position and gain controls will interact.

A 100% modulated transmitter will produce a peak-to-peak envelope equal to twice the shift between the carrier and no carrier traces. See Figure 4-2C. When checking modulation, do not over-drive. Whistle into the microphone with increasing loudness so that maximum modulation is reached without clipping.

Talking into the microphone in a normal manner should produce continuous peaks of 80–90% modulation.

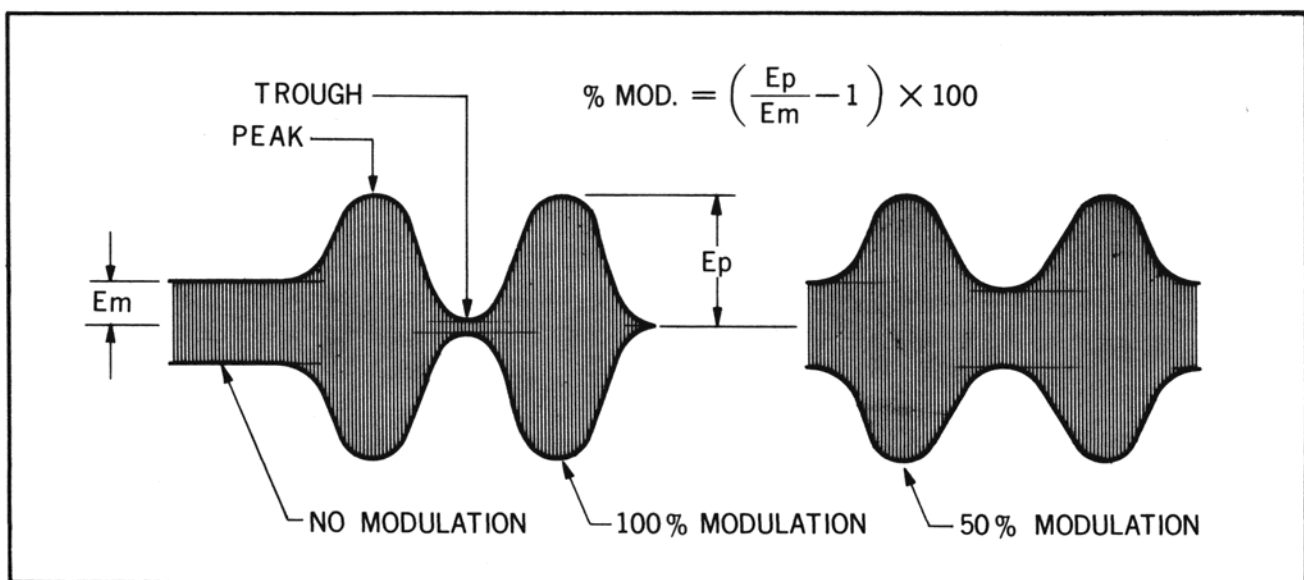

Figure 4-3 Direct Modulation Monitor

**SECTION V  
ADJUSTMENT AND ALIGNMENT**

**5.1 GENERAL**

The PACE CB 166 Transceiver is factory aligned to provide optimum performance. It will not normally require realignment unless major components have been replaced or if the receiver sensitivity has dropped below the specified 0.5 microvolts for 10 dB quieting, or if there is a malfunction of the transmitter.

**NOTE**

*Transmitter tuning adjustments must be made by a technician holding an appropriate FCC license.*

It is recommended that the transceiver be returned to the factory for realignment. However, correct alignment procedures are given in the following paragraphs where this is not feasible.

**5.2 TEST EQUIPMENT**

The transceiver alignment should not be undertaken unless precision equipment is available. Table 4-1 provides a list of recommended test equipment and tools.

**5.3 PRELIMINARY SETUP**

- a. Set the front panel controls as follows:

<u>Control</u>	<u>Setting</u>
SQUELCH	Maximum CCW
VOLUME/OFF	Maximum CCW
PA/CB SW.	CB Position

- b. Connect a regulated DC voltage source of 13.8 volts to the DC power cord (plus to red wire).
- c. Connect a wattmeter and 50 ohm dummy load to the antenna jack. Refer to the wattmeter instruction manual for correct hook up.

**5.4 VCO ADJUSTMENT**

**NOTE**

*This adjustment has been precisely set at the factory and the coil sealed with wax. Do not readjust unless one of the critical tuning components has been replaced.*

- a. Set the channel selector switch to Channel 1.

- b. Connect a DC voltmeter to the cathode of CR27 (TP1). Refer to Figure 5-1.
- c. Turn the transceiver power on.
- d. Adjust L5 for a reading of 2.0 volts on the meter. Use the most sensitive scale for accuracy.
- e. Disconnect the voltmeter.

## 5.5 TRANSMITTER ALIGNMENT

### 5.5.1 Preliminary

- a. Connect a frequency counter to the dummy load across the antenna jack through an appropriate attenuator.
- b. Connect an RF millivoltmeter to the base of Q22. See Figure 5-1.
- c. Preset trimmer C423 to its approximate mid-position.

### 5.5.2 Alignment

- a. Set the channel selector switch to Channel 13.
- b. Adjust L8 and L9 for a maximum indication on the millivoltmeter.
- c. Move the RF millivoltmeter to the base of Q23, and adjust T13 for a maximum reading. Disconnect the millivoltmeter.
- d. Adjust L10, L14, and L15 for a maximum power indication on the wattmeter. This will be about 6 watts.
- e. Detune L14 (clockwise) to reduce the power slightly, then readjust L15 for a maximum power indication.
- f. Repeat step e until the power output comes down to 4 watts. This is the maximum allowable power.
- g. Detune L10 (clockwise) to reduce the power output by 0.1 to 0.2 watts. This provides reduced modulation distortion, and diminishes the possibility of exceeding the maximum allowable power.
- h. Using a spectrum analyzer, adjust C423 for minimum second harmonic (54 MHz) spurious emission.

### 5.5.3 Modulation Limiter Adjustment

- a. Connect an audio generator, set for 2.5 kHz, to the microphone input.
- b. Connect an oscilloscope to the antenna jack (see Section 4.7).
- c. Adjust the generator output level to produce 50% modulation.
- d. Increase the output level of the generator by 16 dB.

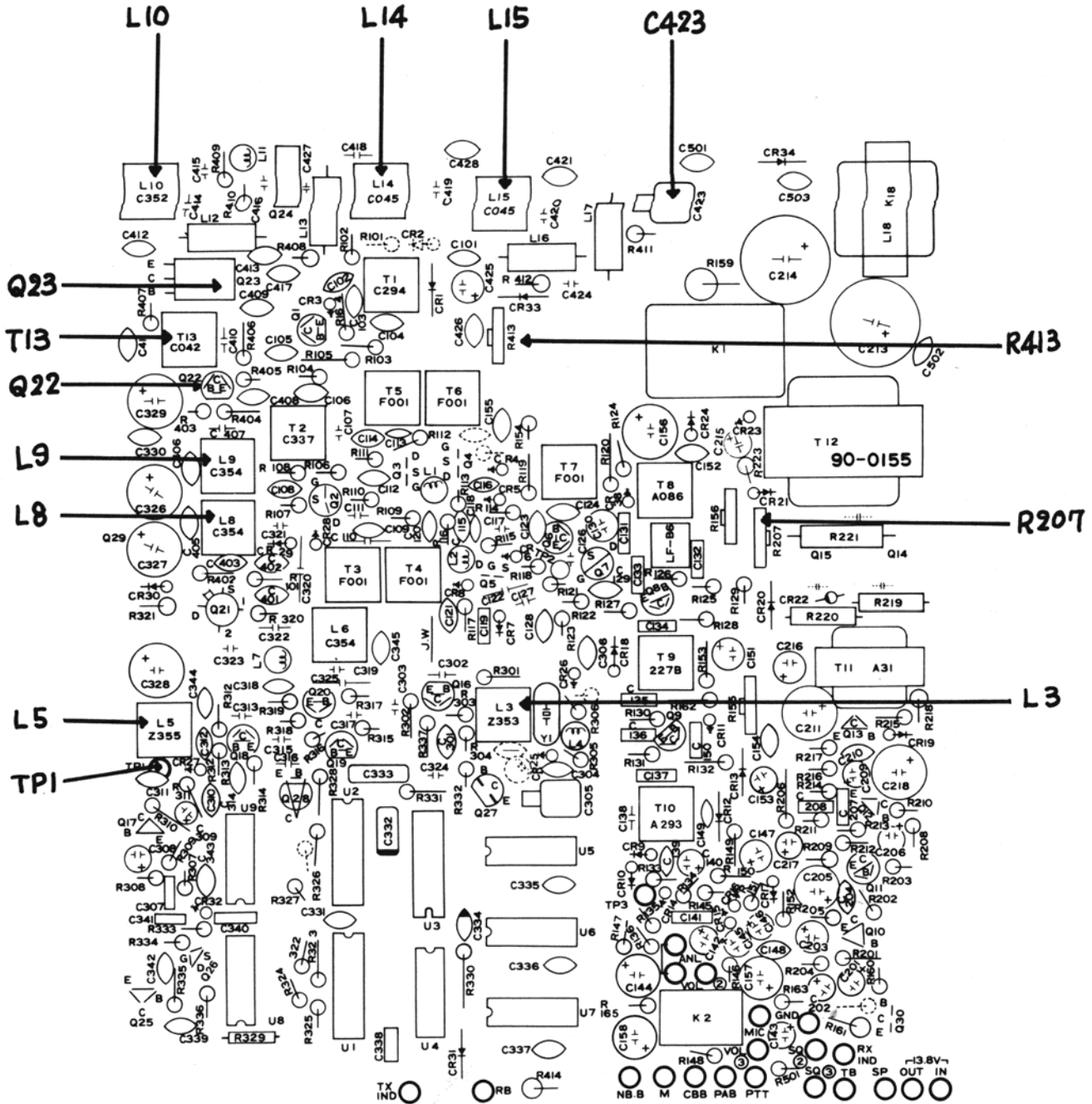

Figure 5-1 PLL and Transmitter Adjustment Locations



- e. Adjust R207 to obtain a maximum of 100% modulation. If set for 95%, this will prevent over-modulation.
- f. Disconnect the generator and oscilloscope.

#### 5.5.4 Reference Oscillator Frequency Adjustment (For Transmit)

- a. Set the channel selector switch to Channel 13 and key the transmitter.
- b. Adjust L3 for a reading, on the frequency counter, of exactly 27.115000 MHz.
- c. Check all other channel frequencies to see that they are within  $\pm 500$  Hz from the assigned center frequency as listed in Column A of Table 4-5.

#### 5.5.5 RF Power Meter Adjustment

- a. Key the transmitter with no modulation.
- b. Adjust R413 for a reading of 4 on the RFO meter scale.

### 5.6 RECEIVER ALIGNMENT

Refer to Figure 5-2 for alignment and testpoint locations.

#### 5.6.1 2nd-IF (455 kHz) Adjustment

- a. Connect a signal generator to TP2 (gate of Q7) through a ceramic 0.047  $\mu$ F capacitor.
- b. Tune the signal generator to 455 kHz and adjust the output for a maximum of 100  $\mu$ V.
- c. Adjust T8, T9, and T10 for a maximum reading on the "S" meter. Reduce the signal generator output, as necessary, to keep the "S" meter at its approximate mid-scale.

#### 5.6.2 RF and 1st-IF Adjustment

- a. Connect an 8-ohm dummy load and an AC VTVM to the external speaker jack through a miniature phone plug.
- b. Connect the signal generator output directly to the antenna connector. Tune the signal generator to 27.115 MHz with 30% modulation of a 1 kHz signal.
- c. Turn the channel selector switch to Channel 13.
- d. Adjust the output level of the signal generator for a sufficient output level to cause a mid-scale indication on the meter. (Select the most sensitive scale.)
- e. Adjust T1, T2, T3, T4, and T7 for a maximum indication on the voltmeter. Decrease the generator output level, as necessary, to prevent overdriving the meter.

- f. Reduce the generator output level to 0.5  $\mu$ V, and adjust L6 for a maximum indication on the voltmeter.
- g. Repeat step e.

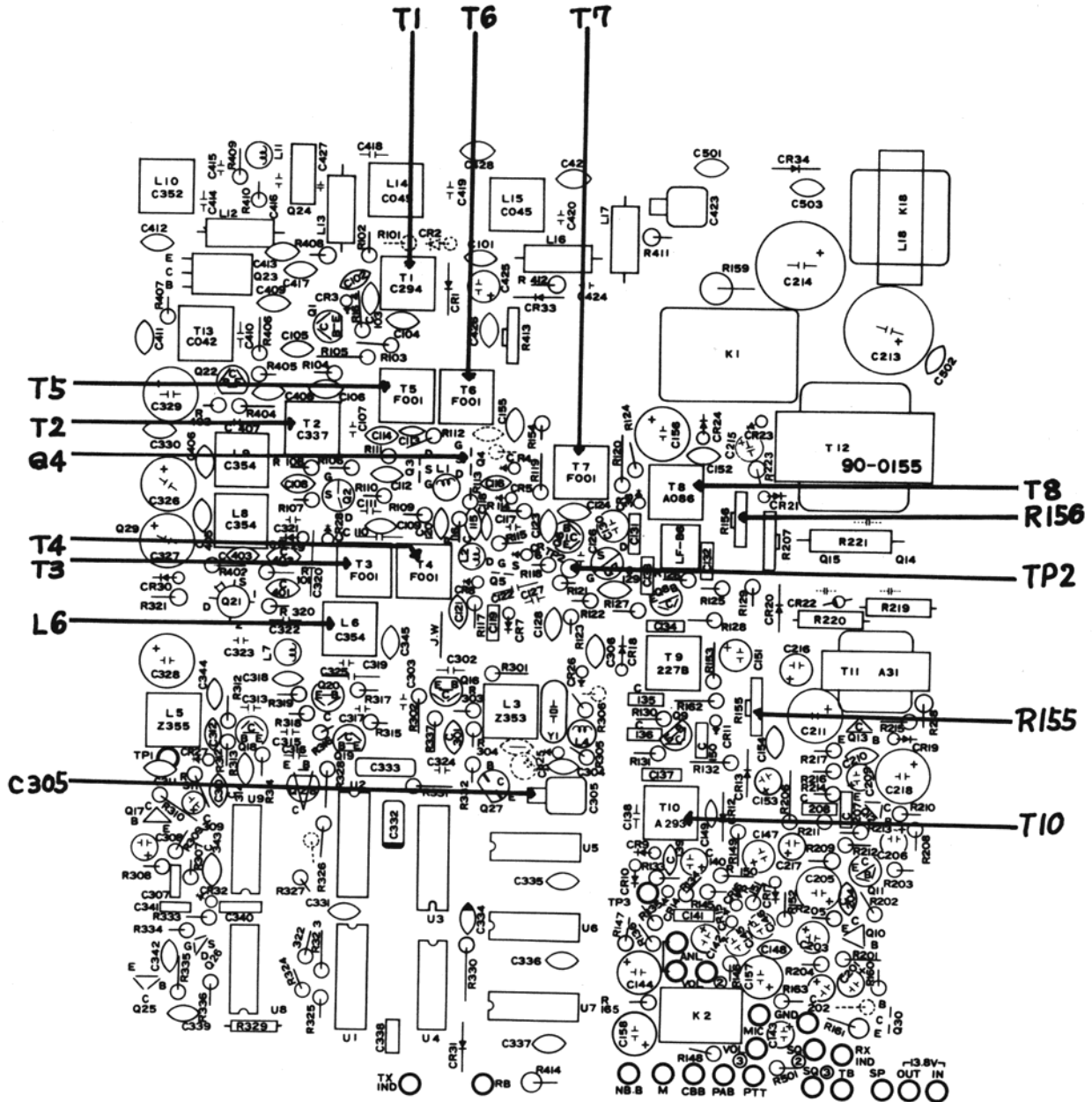

Figure 5-2 Receiver Adjustment Locations

### 5.6.3 Tight Squelch Sensitivity Adjustment

- a. Leave all instruments connected as shown for previous step.
- b. Turn the squelch control fully clockwise.
- c. Adjust the signal generator output level to 1000  $\mu\text{V}$ .
- d. Adjust trimmer potentiometer R156 until an indication of audio output just starts to appear on the VTVM.

### 5.6.4 "S" Meter Adjustment

- a. Leave all instruments connected as shown for previous step.
- b. Turn the squelch control fully counterclockwise.
- c. Set the signal generator output level to 100  $\mu\text{V}$ .
- d. Adjust trimmer potentiometer R155 for an S9 reading on the "S" meter.

### 5.6.5 Noise Blanker Adjustment

- a. Leave all instruments connected as shown for previous step.
- b. Connect the RF probe from the oscilloscope to the drain of Q4.
- c. Turn the noise blanker switch on.
- d. Set the RF signal generator frequency to 25.8 MHz without modulation, and adjust the output level until a signal indication starts to appear on the oscilloscope.
- e. Adjust T5 for a maximum signal indication on the oscilloscope.
- f. Reset the RF signal generator frequency to 26.3 MHz.
- g. Adjust T6 for a minimum signal indication on the oscilloscope.
- h. Disconnect all instruments.

### 5.6.6 Reference Oscillator Frequency Adjustment (for Receive)

- a. Connect the 50 ohm dummy load to the antenna jack.
- b. Connect the frequency counter to TP2.
- c. Adjust trimmer capacitor C305 for a frequency reading of 10.240 MHz.
- d. Disconnect all instruments.

This completes the alignment procedure.

## SECTION VI ILLUSTRATIONS AND PARTS LIST

### 6.1 GENERAL

The schematics and parts locators in this section are for the PACE CB 166 Transceiver. Part numbers and descriptions are keyed to schematic reference numbers. Standard value resistors and capacitors may be purchased from any electronic parts distributor, and are not listed. If required, these parts may be ordered from PACE by specifying the schematic reference number and its description.

**Table 6-1  
Parts List**

Reference Number	Description	Part Number
<b>CAPACITORS</b>		
C119, 131 thru 137, 141, 150 . . .	Mylar, 0.04 $\mu\text{F}$ . . . . .	IP 22-0018
C140, 146, 309 . . . . .	Electrolytic, 0.22 $\mu\text{F}$ 25 V . . . . .	IP 22-0044
C142, 147, 151, 157 . . . . .	Electrolytic, 10 $\mu\text{F}$ 16 V . . . . .	IP 22-0004
C143, 145, 153, 203, 206, 209, 215, 308, 425 . . . . .	Electrolytic, 1 $\mu\text{F}$ 50 V . . . . .	IP 22-0001
C144, 205 . . . . .	Electrolytic, 47 $\mu\text{F}$ 16 V . . . . .	IP 22-0006
C156, 211, 218, 326, 328, 329 . . .	Electrolytic, 220 $\mu\text{F}$ 16 V . . . . .	IP 22-0009
C158, 327 . . . . .	Electrolytic, 100 $\mu\text{F}$ 16 V . . . . .	IP 22-0008
C201, 202, 216, 217 . . . . .	Electrolytic, 4.7 $\mu\text{F}$ 25 V . . . . .	IP 22-0003
C207 . . . . .	Mylar, 0.03 $\mu\text{F}$ . . . . .	IP 22-0068
C208, 307, 341 . . . . .	Mylar, 0.02 $\mu\text{F}$ . . . . .	IP 22-0017
C213, 214 . . . . .	Electrolytic, 1000 $\mu\text{F}$ 16 V . . . . .	IP 22-0051
C305 . . . . .	Variable, 40 pF . . . . .	IP 22-0046
C332 . . . . .	Mylar, 0.1 $\mu\text{F}$ . . . . .	IP 22-0047
C333 . . . . .	Mylar, 0.2 $\mu\text{F}$ . . . . .	IP 22-0069
C338 . . . . .	Mylar, 0.0047 $\mu\text{F}$ . . . . .	IP 22-0036
C340 . . . . .	Mylar, 0.001 $\mu\text{F}$ . . . . .	IP 22-0014
C423 . . . . .	Variable, 10 pF . . . . .	IP 22-0045
<b>RESISTORS</b>		
R155, 156, 207 . . . . .	Semi-fixed, 10 k $\Omega$ . . . . .	IP 24-0005
R157 . . . . .	Variable, 10 k $\Omega$ (B) . . . . .	IP 24-0017
R158 . . . . .	Variable, 10 k $\Omega$ (D) . . . . .	IP 24-0049
R159 . . . . .	Oxide-Film, 200 $\Omega$ 2 W . . . . .	IP 23-0011
R221 . . . . .	Oxide-Film, 1 $\Omega$ 1 W . . . . .	IP 23-0019
R408 . . . . .	2.2 $\Omega$ 1/2 W . . . . .	IP 23-0018
R413 . . . . .	Semi-fixed, 100 k $\Omega$ . . . . .	IP 24-0002

Table 6-1 (continued)

## DIODES, TRANSISTORS AND INTEGRATED CIRCUITS

CR1, 15, 17, 18, 21, 26, 28, 29, 31 . . . . .	Diode, WG713 . . . . .	IP 20-0145
CR2 thru 7, 16, 20, 25, 32, 33, 37, 38 . . . . .	Diode, 1N34A . . . . .	IP 20-0015
CR8 thru 13 . . . . .	Diode, 1N60 . . . . .	IP 20-0060
CR14 . . . . .	Diode, 1S2472 . . . . .	IP 20-0021
CR19, 24 . . . . .	Diode, BZ090 . . . . .	IP 20-0019
CR22 . . . . .	Diode, 1S1211 . . . . .	IP 20-0023
CR23, 34 . . . . .	Diode, 1N4002 . . . . .	IP 20-0120
CR27 . . . . .	Diode, MV-201 . . . . .	IP 20-0204
CR30 . . . . .	Diode, 1S331 . . . . .	IP 20-0203
CR35 . . . . .	L.E.D., Yellow . . . . .	IP 28-0010
CR36 . . . . .	L.E.D., SL103 . . . . .	IP 28-0011
Q1, 6 . . . . .	Transistor, 2SC710B . . . . .	IP 20-0001
Q2, 3, 4, 7 . . . . .	Transistor, 2SK19GR . . . . .	IP 20-0012
Q5, 26 . . . . .	Transistor, 2SK30Y . . . . .	IP 20-0078
Q8, 9, 16, 18, 19, 20, 22, 27, 28 .	Transistor, 2SC710C . . . . .	IP 20-0002
Q10 . . . . .	Transistor, 2SA495Y . . . . .	IP 20-0159
Q11 . . . . .	Transistor, 2SD187R . . . . .	IP 20-0076
Q12, 13, 17, 25, 30 . . . . .	Transistor, 2SC372Y . . . . .	IP 20-0006
Q14, 15 . . . . .	Transistor, 2SC1014 . . . . .	IP 20-0172
Q21 . . . . .	Transistor, 3SK45B . . . . .	IP 20-0157
Q23 . . . . .	Transistor, 2SC495 . . . . .	IP 20-0103
Q24 . . . . .	Transistor, 2SC1306 . . . . .	IP 20-0155
Q29 . . . . .	Transistor, 2SC1061 . . . . .	IP 20-0007
U1, 2, 3 . . . . .	Integrated Circuit, 9316/74161 . . . . .	IP 20-0209
U4 . . . . .	Integrated Circuit, 74H22/9H22 . . . . .	IP 20-0208
U5, 6 . . . . .	Integrated Circuit, 7493/9393 . . . . .	IP 20-0207
U7 . . . . .	Integrated Circuit, 7474 . . . . .	IP 20-0206
U8 . . . . .	Integrated Circuit, 7400/9N00 . . . . .	IP 20-0205
U9 . . . . .	Integrated Circuit, MC4044P . . . . .	IP 20-0210

## CHOKES, INDUCTORS AND TRANSFORMERS

L1, 2 . . . . .	RF Choke, 470 $\mu$ H . . . . .	IP 21-0195
L3 . . . . .	RF Coil, Z353Z . . . . .	IP 21-0279
L4 . . . . .	RF Choke, 22 $\mu$ H . . . . .	IP 21-0072
L5 . . . . .	RF Coil, Z355N . . . . .	IP 21-0281
L6, 8, 9 . . . . .	RF Coil, C354N . . . . .	IP 21-0280
L7 . . . . .	RF Choke, 3.3 $\mu$ H . . . . .	IP 21-0183
L10 . . . . .	RF Coil, C352Z . . . . .	IP 21-0282
L11 . . . . .	RF Choke, 10 $\mu$ H . . . . .	IP 21-0073
L12 . . . . .	RF Choke, 2.5 $\mu$ H R . . . . .	IP 21-0227
L13 . . . . .	RF Choke, 0.65 $\mu$ H . . . . .	IP 21-0071
L14, 15 . . . . .	RF Coil, C045Z . . . . .	IP 21-0096
L16 . . . . .	RF Choke, 0.22 $\mu$ H . . . . .	IP 21-0098
L17 . . . . .	RF Choke, 0.85 $\mu$ H . . . . .	IP 21-0099
L18 . . . . .	AF Choke, K-18 . . . . .	IP 21-0112

Table 6-1 (continued)

T1	RF Transformer, C294D	IP 21-0236
T2	RF Transformer, C337B	IP 21-0277
T3 thru 7	RF Transformer, F001A	IP 21-0239
T8	RF Transformer, A086A	IP 21-0198
T9	RF Transformer, 227B	IP 21-0244
T10	RF Transformer, A293A	IP 21-0278
T11	AF Transformer, A-31	IP 21-0075
T12	AF Transformer, E-67	IP 21-0283
T13	RF Transformer, C042D	IP 21-0093

## MISCELLANEOUS

DS1, 2	Lamp, 16 V 40 mA	IP 28-0009
FL1	Filter, LF-B6 455 kHz	IP 31-0048
J1, 2	Jack, Speaker	IP 26-0005
J3	Jack, Antenna	IP 26-0013
J4	Jack, Microphone	IP 26-0014
K1	Relay, 12 V	IP 32-0007
K2	Relay, 12 V	IP 32-0009
M1	Meter, A-36	IP 27-0011
S1	Switch, 24-Position Rotary	IP 25-0043
S2, 3, 4	Switch, Lever DP-DT	IP 25-0044
Y1	Crystal, 10.240 MHz	IP 31-0090
	Bezel, Front	IP 30-0167
	Bracket, Mounting	IP 30-0175
	Cabinet	IP 30-0174
	Hanger, Microphone	IP 30-0061
	Mounting Screw	IP 30-0176
	Knob, Channel Selector	IP 30-0165
	Knob, VOL and SQ	IP 30-0166
	Microphone, 1368WT	IP 29-0016
	Speaker, 8 $\Omega$ 2 W	IP 29-0017
	Panel, Channel	IP 30-0169
	Panel, CB 166	IP 30-0168
	Panel, Connector	IP 30-0172
	Panel, Squelch	IP 30-0170
	Panel, Volume	IP 30-0171

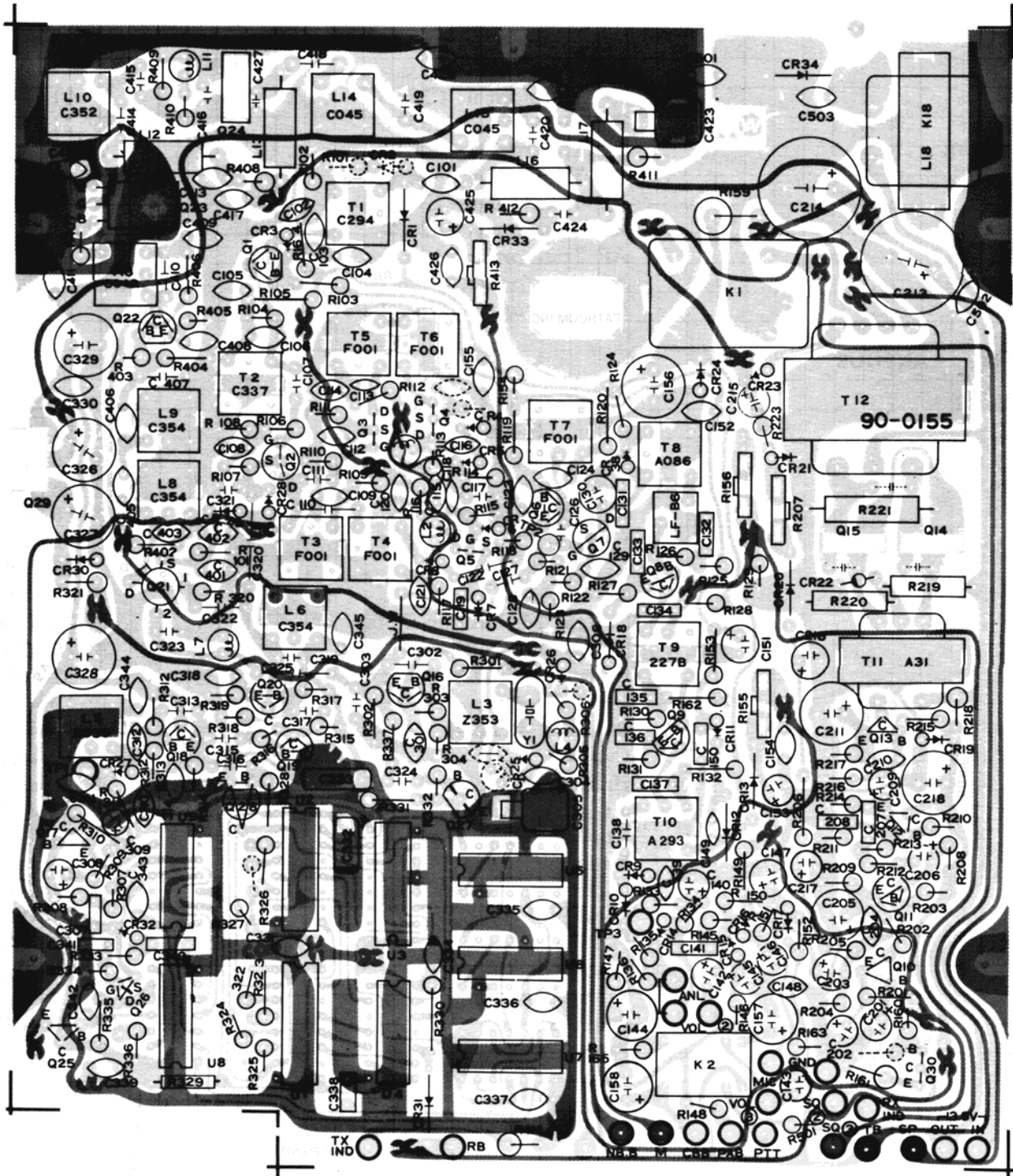

Figure 6-1 Parts Locator

**APPENDIX A  
INTEGRATED CIRCUIT INFORMATION**

This appendix contains information on the integrated circuits (IC's) used in the CB 166 Mobile Transceiver. Table A-1 is a cross-referenced list (commercial type number vs. PACE part number) of the IC type used.

Data sheets are provided for each integrated circuit type. Each data sheet includes the schematic diagram and logic symbol of the IC.

**Table A-1  
Integrated Circuit Cross-Reference**

<b>PACE PART NUMBER</b>	<b>PART DESCRIPTION</b>	<b>COMMERCIAL PART NUMBER</b>
IP 20-0205	Quadruple 2-Input Nand Gate	7400/9N00
IP 20-0206	Dual D Type Edge Triggered Flip-Flop	7474
IP 20-0207	4-Bit Binary Counter	7493/9393
IP 20-0208	4-Input Nand Buffer	SN7422N
IP 20-0209	4-Bit Counter	9316/74161
IP 20-0210	Phase-Frequency Detector	MC4044P



PHASE-FREQUENCY DETECTOR

<p style="text-align: center;"><b>LOGIC SYMBOL</b></p> <p style="margin-top: 10px;">VCC = Pin 14 GND = Pin 7</p>	<table border="1" style="width: 100%; border-collapse: collapse;"> <tr> <td style="width: 50%; text-align: center;">                 PACE PART NO. IP 20-0210             </td> <td style="width: 50%; text-align: center;">                 MANUFACTURERS TYPE NO. MC 4044P             </td> </tr> </table> <div style="text-align: center; margin-top: 20px;"> </div>	PACE PART NO. IP 20-0210	MANUFACTURERS TYPE NO. MC 4044P
PACE PART NO. IP 20-0210	MANUFACTURERS TYPE NO. MC 4044P		

**FUNCTIONS**

RF—Reference Frequency Input VF—Variable Frequency Input U1, D1—Phase/Frequency Detector Outputs U2, D2—Phase Detector Outputs	PU, PD—Charge Pump Inputs UF, DF—Charge Pump Outputs A—Amplifier Input B—Amplifier Output
---	--

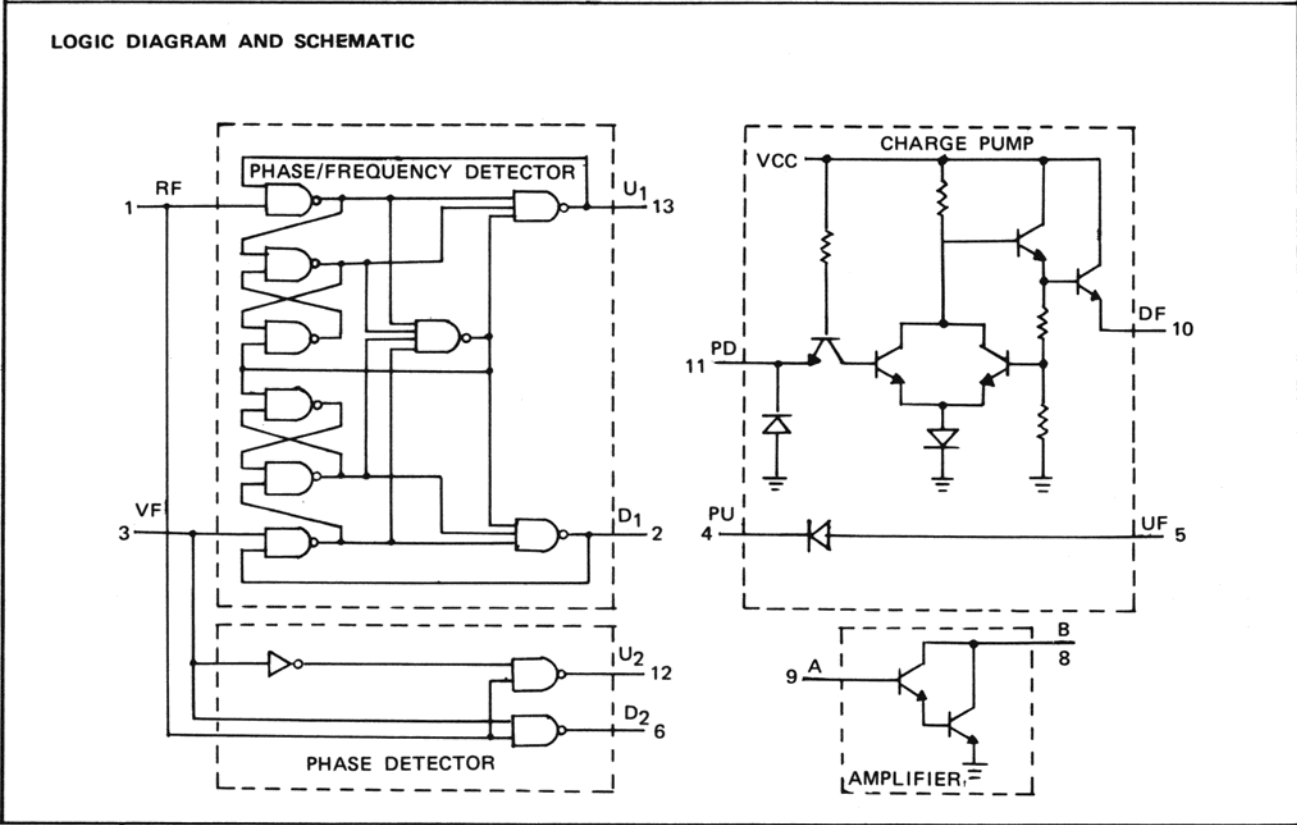

**QUADRUPLE 2-INPUT NAND GATE**

PACE PART NO.	MANUFACTURERS TYPE NO.
IP 20-0205	9N00/7400



POSITIVE LOGIC

$$Y = \overline{A \cdot B}$$

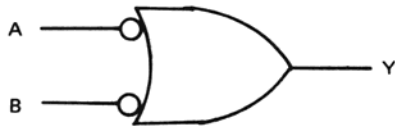

NEGATIVE LOGIC

$$Y = \overline{\overline{A} + \overline{B}}$$

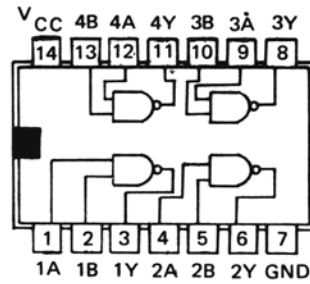

**SCHEMATIC (EACH GATE)**

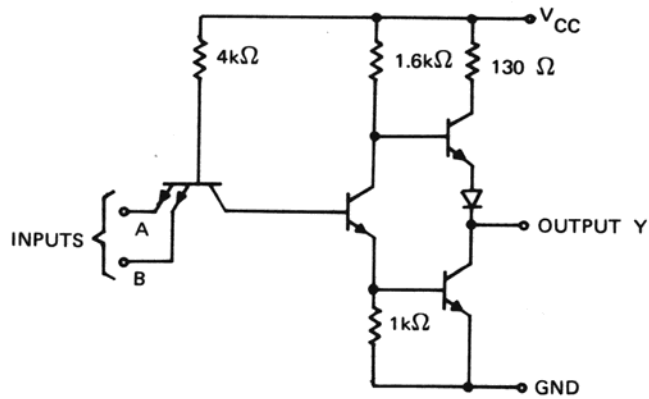

NOTE: COMPONENT VALUES SHOWN ARE NOMINAL

DUAL 4-INPUT NAND BUFFER

PACE PART NO.	MANUFACTURERS TYPE NO.
IP 20-0208	TI, SN7422N



POSITIVE LOGIC

$$Y = \overline{ABCD}$$

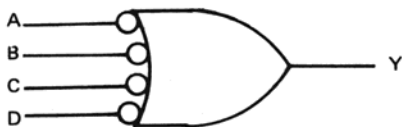

NEGATIVE LOGIC

$$Y = \overline{A + B + C + D}$$

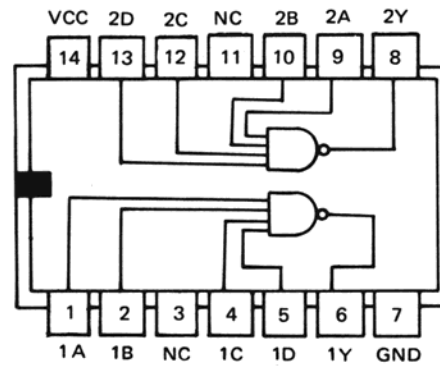

SCHEMATIC (EACH GATE)

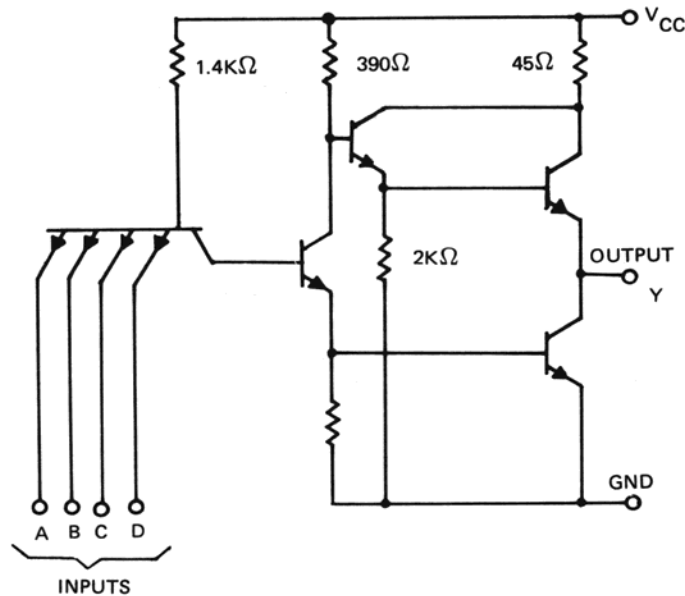

NOTE: COMPONENT VALUES SHOWN ARE NOMINAL.

**DUAL D TYPE EDGE TRIGGERED FLIP-FLOP**

**LOGIC FUNCTION**

PACE  
PART NO.

MANUFACTURERS  
TYPE NO.

IP 20-0206

9N74/7474

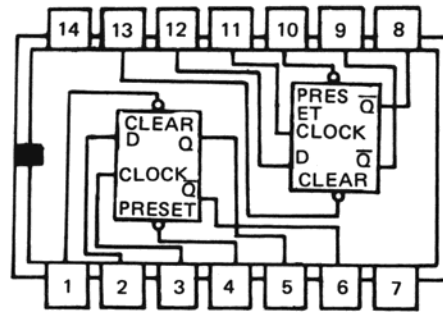
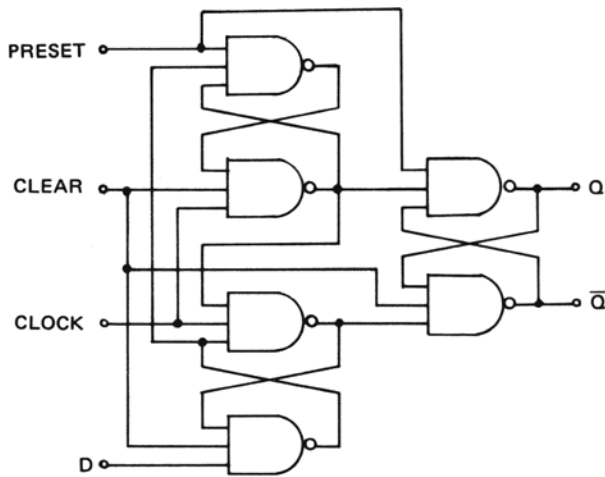

**SCHEMATIC (EACH FLIP-FLOP)**

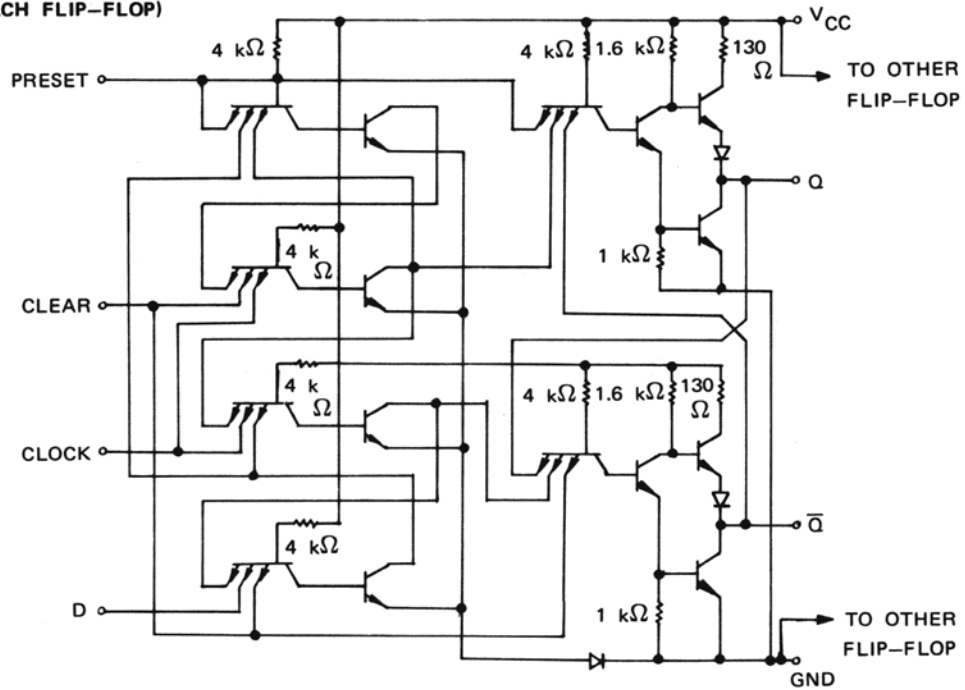

NOTE: COMPONENT VALUES SHOWN ARE NOMINAL.

4-BIT BINARY COUNTER

PACE PART NO.	MANUFACTURERS TYPE NO.
IP 20-0207	9393/7492

LOGIC SYMBOL

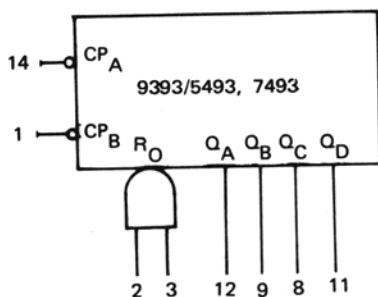

V<sub>CC</sub> = Pin 5  
 GND = Pin 10  
 N.C. = Pins 4, 6, 7, 13

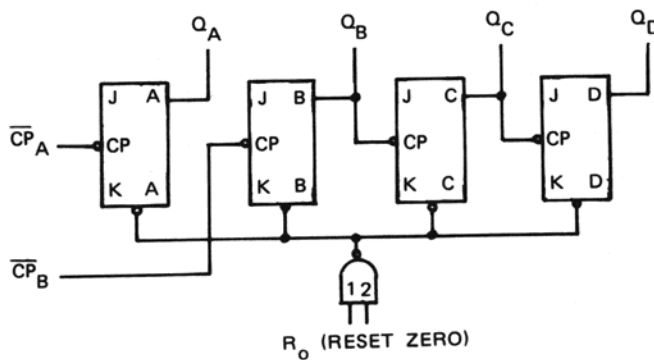
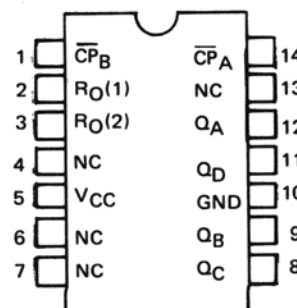

**SYNCHRONOUS 4-BIT COUNTER**

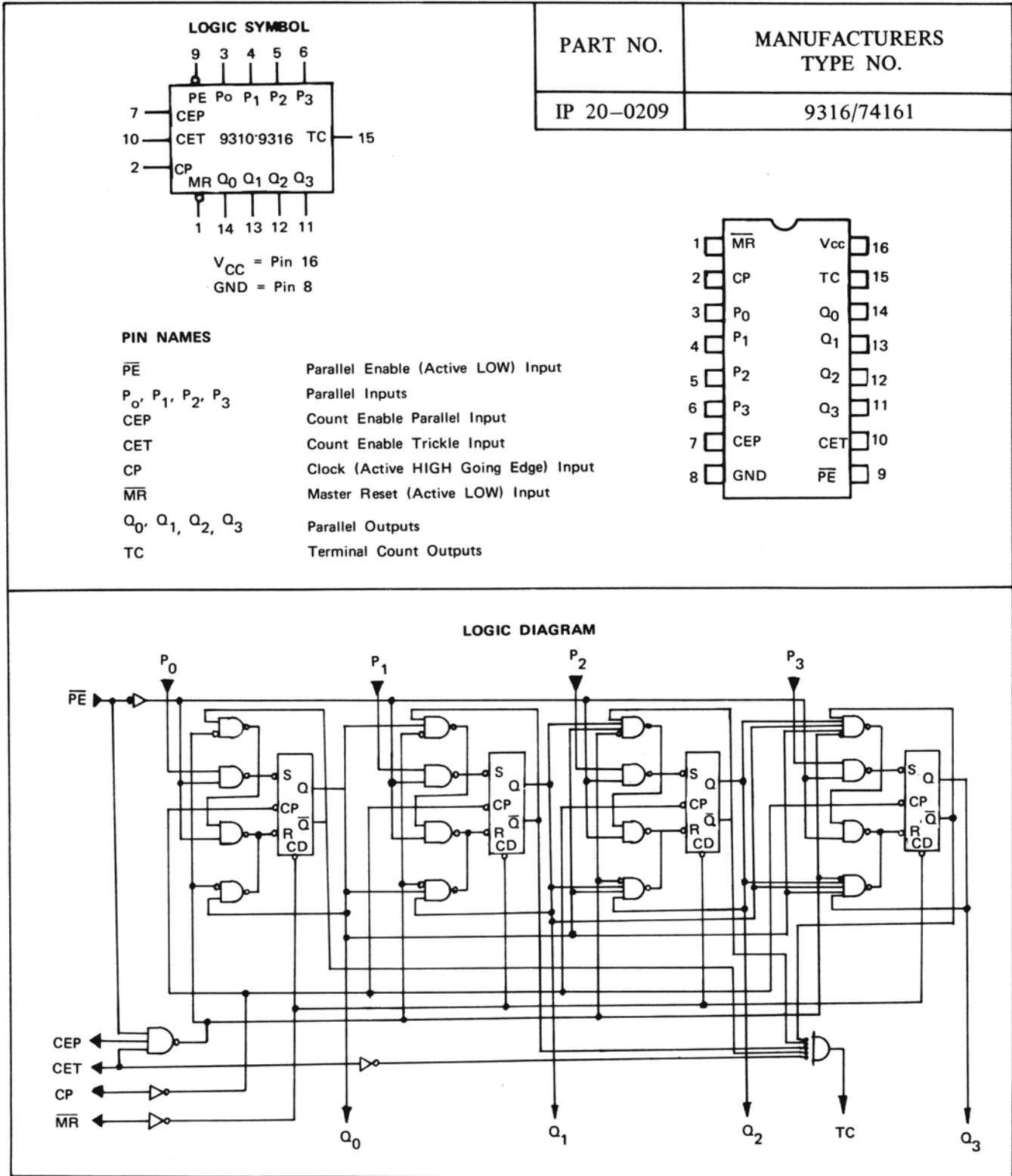

**LOGIC DIAGRAM**

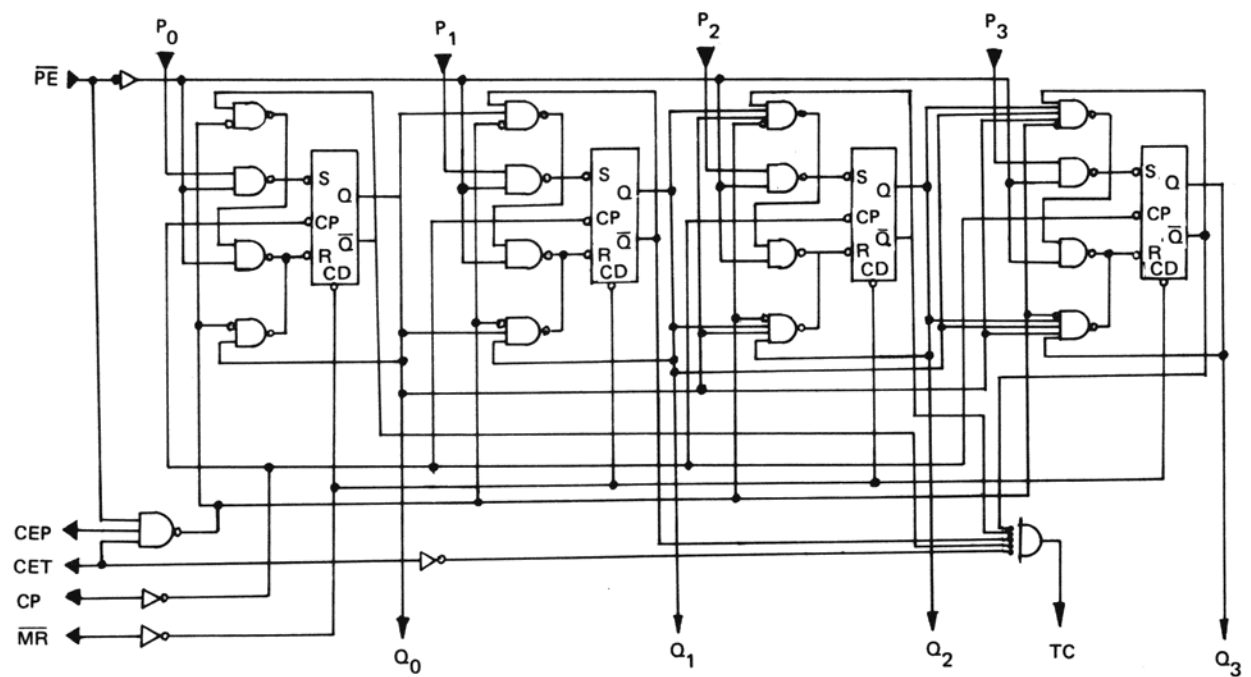

**NOTES**