



LAFAYETTE

MODEL HB-525E

5-Watt

Mobile Two-Way Radio



Stock No.99-32369WX

**23-CHANNEL
SOLID-STATE
CB TRANSCEIVER**

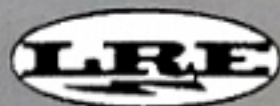

INSTALLATION AND OPERATING MANUAL

SPECIFICATIONS

RECEIVER			
CIRCUIT TYPE	Dual conversion superheterodyne; Crystal frequency synthesizer provides 23 crystal controlled transmit and receive channels. "Delta" tuning of ± 2 KHz on each channel plus mechanical filter.		
SENSITIVITY	0.5 μ V for 10 db S/N to N ratio at 30% at 1000 Hz modulation.		
SELECTIVITY	6 db down at ± 2.5 KHz; 45 db down at ± 8 KHz.		
INTERMEDIATE FREQUENCY	1st IF: 11.275 MHz. 2nd IF: 455 KHz.		
AUDIO OUTPUT	2.7 watts into ext. spkr. jack.		
AUXILIARY CIRCUITS	Series gate noise limiter, Variable squelch, PA., EX., S/P-RF meter.		
TRANSMITTER			
FINAL STAGE D.C POWER INPUT	5 watts maximum.		
RANGE BOOST	Yields high average modulation at average voice levels.		
CARRIER DEVIATION	Exceeds FCC requirements.		
HARMONICS SUPPRESSION	Exceeds FCC requirements.		
ANTENNA MATCHING	Nominal 50 Ω (may be used with 30-100 Ω antennas).		
SEMI-CONDUCTORS			
TRANSISTORS	TR1~TR3:	2SCF11	Silicon Planar
	TR4~TR6:	2SCF5	Silicon Planar
	TR7:	2SCF6	Epitaxial Silicon Planar
	TR8:	2SCF8	Epitaxial Silicon Planar
	TR9:	2SCF2	Silicon Planar
	TR10~TR13, 17:	2SCF11	Silicon Planar
	TR14:	2SBF1	Germanium
	TR15:	2SDF1	Germanium.
	TR16:	2SBF1A	Germanium
	TR18, 19:	2SBF5	Germanium
DIODES	D1:	1S1555	Silicon
	D2-D5, 7, 8, 10:	1S34	Germanium
	D6:	RD-9A	Zener
	D9:	VO-6C	Silicon
GENERAL			
POWER SUPPLY	12.6 volts DC, negative or positive ground (with internal switching).		
ACCESSORIES	1) Push-to-talk dynamic microphone.		
	2) DC power cable (1.5 amp fused).		
	3) Mobile mounting bracket.		

GENERAL INSTRUCTIONS

The Lafayette HB-525E Transceiver is a combination transmitter and receiver designed for use in Class "D" operation in the 27 MHz Citizens Radio service. It is designed to meet the Federal Communications Commission requirements applicable to equipment operating in this service under class "D" emission, and not to be used for any other purpose. Part 95 of the FCC regulations defines operation in this service and the licensee is required to read and understand these regulations prior to operating a CB transmitter. Copies of Manual VI (covering the FCC regulations for the Citizens Band Radio Service) includes Part 95 and are available for \$1.25 from the Superintendent of Documents, U. S. Government Printing Office, Washington, D. C. A station license may be obtained by submitting a properly completed Station License Application, Form 505, as directed.

It is illegal to operate the transmitter section of this transceiver prior to receiving a valid station license and "call sign". A properly completed Identification Card FCC Form 452-C must be attached to the transmitter.

The unit will provide economical and reliable two-way radio communication in its intended application if installed and operated in accordance with instructions contained herein.

GENERAL DESCRIPTION

The HB-525E is an extremely compact all-transistor 2-way radio providing 23 crystal-controlled transmit and receive channels in the 27 MHz Citizens Band.

Designed and built for reliable, trouble-free performance, the HB-525E uses rugged, heat-resistant transistors in all critical areas. Current drain on 12 volts DC is exceptionally low, permitting continuous mobile operation for long periods of time . . . even with the automobile's motor switched off.

The HB-525E is designed to operate from 12 volt DC (positive or negative ground), but may also be operated from 105-120 volts 50/60 Hz AC when used with the optional solid-state AC power supply unit Model HB-502. The transceiver may also be operated from a 6 volt DC source when used with the optional DC converter unit, Model HB-505.

RECEIVER

The receiver is a highly sensitive and selective double-conversion superheterodyne incorporating a high-quality Mechanical Filter in the 455 KHz IF section for high adjacent channel rejection. The receiver may be operated on any channel in the Citizens Band by means of a front panel selector switch. A squelch control is incorporated which can be used to "quiet" the receiver when no signal is being received and, being variable, can be adjusted for varying degrees of sensitivity to signals. Also included is a full-time Automatic Noise Limiter which materially reduces ignition noise and other undesirable noise interference, and an S/P-RF meter for indicating strength of received signal (s).

The internal audio stage amplifier and speaker may be used for AUX operation in conjunction with an external source through the EX jack.

TRANSMITTER

The transmitter may be operated on any channel (crystal-controlled) in the Citizens Band and uses a 6-stage circuit (excluding the frequency synthesizer) to develop the legal maximum of 5 watts plate power input to the final RF stage. A special feature in the transmitter is the fulltime "Range-Boost" circuit which concentrates more audio power into the sidebands by providing high average modulation on all syllables. This results in a greater effective range of the transmitted signal at all times. A push-to-talk dynamic microphone (supplied) offers convenient transmit-receive switching which operates through a relay for dependable operation. The microphone and audio stages may be used for public address operation in conjunction with an external PA speaker. The S/P-RF meter indicates relative power output (P-RF).

DC POWER SUPPLY

As supplied, the HB-525E is ready for connection to a 12 volt DC, negative ground system (most U. S. vehicles now employ this system). However, the transceiver may be operated with a positive ground system by simply interchanging two wires terminated with push-on lugs in the unit. DC power is fed to the HB-525E by means of a plug-in cord. For safety, one lead (red) is equipped with an in-line fuse of 1.5 amps.

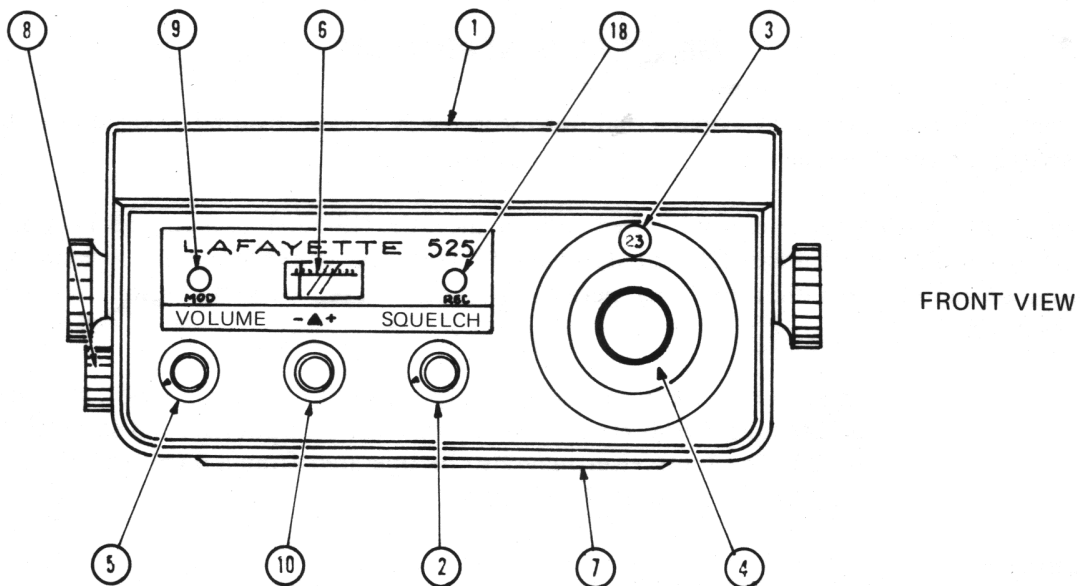

OPERATING CONTROLS AND FEATURES

- (1) MOUNTING BRACKET Specially designed bracket simplifies mobile installation - has "quick-release" feature for fast removal of transceiver.
- (2) SQUELCH This control is used to "quiet" the receiver during "no-signal" conditions. Degree of sensitivity to incoming signals is adjustable. Full clockwise provides maximum squelch;

- (3) CHANNEL INDICATOR Illuminated window shows channel selected.
- (4) CHANNEL/PA/EX Rotary switch selects one of 23 channels for transmit and receive operation, as well as PA and EX (Auxiliary).
- (5) VOLUME/ON-OFF Varies the sound output from the speaker. Also incorporates an "on-off" power switch at the extreme counter-clockwise position.
- (6) S/P-RF METER Indicates signal strength of received signal and is automatically switched to indicate relative power output when in transit mode.
- (7) SPEAKER PM-type 4 x 6" oval speaker located behind grille on underside.
- (8) MICROPHONE SOCKET Four-pin socket for attachment of push-to-talk microphone (supplied).
- (9) TRANSMIT INDICATOR Lamp lights up in the transmit mode. Also acts as modulation indicator.
- (10) DELTA TUNE 3-position switch (-2.0 KHz, Normal, +2.0 KHz) which permits "fine" tuning for reception of stations that are slightly off frequency.

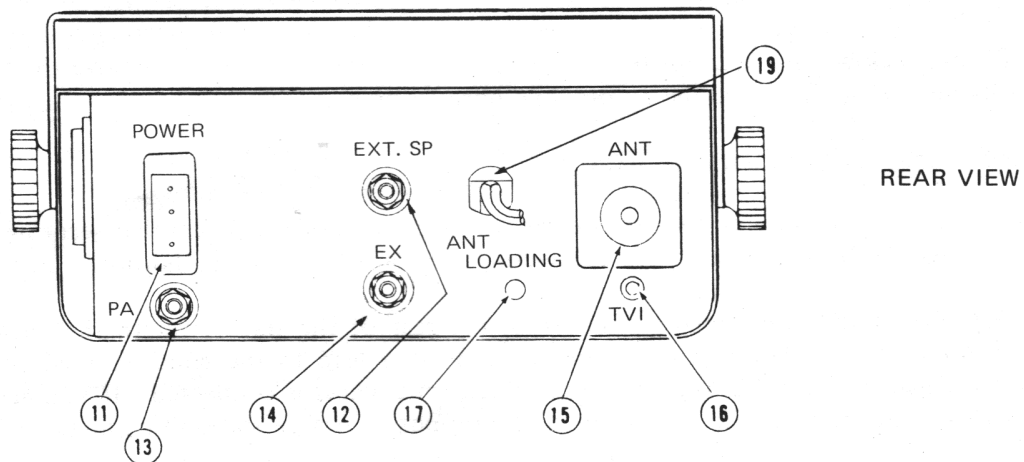

- (11) DC POWER SOCKET DC power for the transceiver supplied through this socket.
- (12) EXT SPKR/PHONES Allows use of headphone for private listening. Insertion of plug automatically silences internal speaker.

- (13) PA OPERATION Insertion of plug into PA jack, (16~32 ohms external speaker) permits PA operation when channel selector is placed in PA position.
- (14) AUX OPERATION Insertion of Plug into EX jack, permits AUX operation when channel selector is placed in EX position.
- (15) ANTENNA RECEPTACLE. For antenna lead-in cable with matching PL-259 connector.
- (16) TVI TRAP Adjustable coil for minimizing TV interference. Preset at factory and does not usually require readjustment.
- (17) ANTENNA LOADING Adjustment for matching unit to the antenna – assures maximum radiated output.
- (18) RECEIVE INDICATOR. Lamp Lights up in the receive mode.
- (19) BURGLAR ALARM LEADS Two leads for use of alarm circuit.

BURGLAR ALARM CIRCUIT

The transceiver is equipped with a built-in switching circuit designed to discourage the removal of the unit by unauthorized persons. This switching circuit, which operates upon removal of the left-hand knurled thumbscrew from the transceiver, terminates in two zip-cord leads at the rear of the unit. When these leads are connected to the automobile horn circuit and ground, as indicated below, any attempt to remove the thumbscrew in order to remove the transceiver from its mounting will cause the automobile horn to blow.

CONNECTING THE ALARM LEADS

NOTE: Be sure to mount the transceiver in the automobile with knurled securing screws at each side tightened before connecting the alarm leads to the horn circuit.

Connect one of the two zip-cord leads from the rear of the transceiver to the chassis of the vehicle (or metal dashboard, etc.). Connect the other lead to the same terminal on the horn relay to which the horn button lead from the steering wheel is connected. If you are in doubt about this connection, check with your local automotive service station or garage.

IMPORTANT: Be sure to install these leads as inconspicuously as possible so that they are concealed from view.

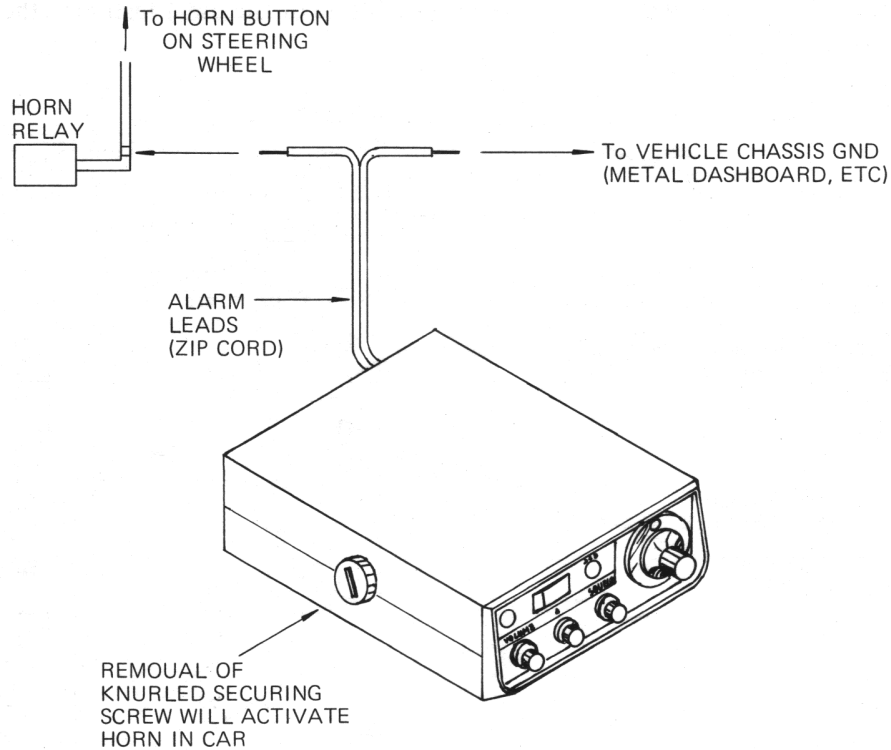

MOBILE INSTALLATION

DC POWER SUPPLY

WARNING: As supplied, the HB-525E is wired to operate from a battery source of 12.6 volts DC, on negative ground systems. Connecting the unit to a positive ground vehicle without making the necessary internal wiring change will blow 1.5A primary fuse. Before making any power connections you must determine whether the vehicle has a negative or positive ground electrical system and follow the appropriate instructions below.

NEGATIVE GROUND SYSTEMS

Connect the fused power lead (RED) of the DC power cord to the positive or "hot" side of the electrical system. Points normally available for this purpose are the accessory post on the ignition switch, the voltage regulator side of the ammeter or the accessory side of the fuse block. The other lead (BLACK) should be connected to the metal firewall or any other point that is connected to the vehicle chassis.

POSITIVE GROUND SYSTEMS

Before using the HB-525E for operation in vehicles with a positive ground electrical system, the following internal wiring change must be made.

1. Place the transceiver upside down (speaker grille upward) with the front control panel facing you.

- Remove the four Phillips head screws (two on each side of the unit) fastening the uppermost chassis cover.

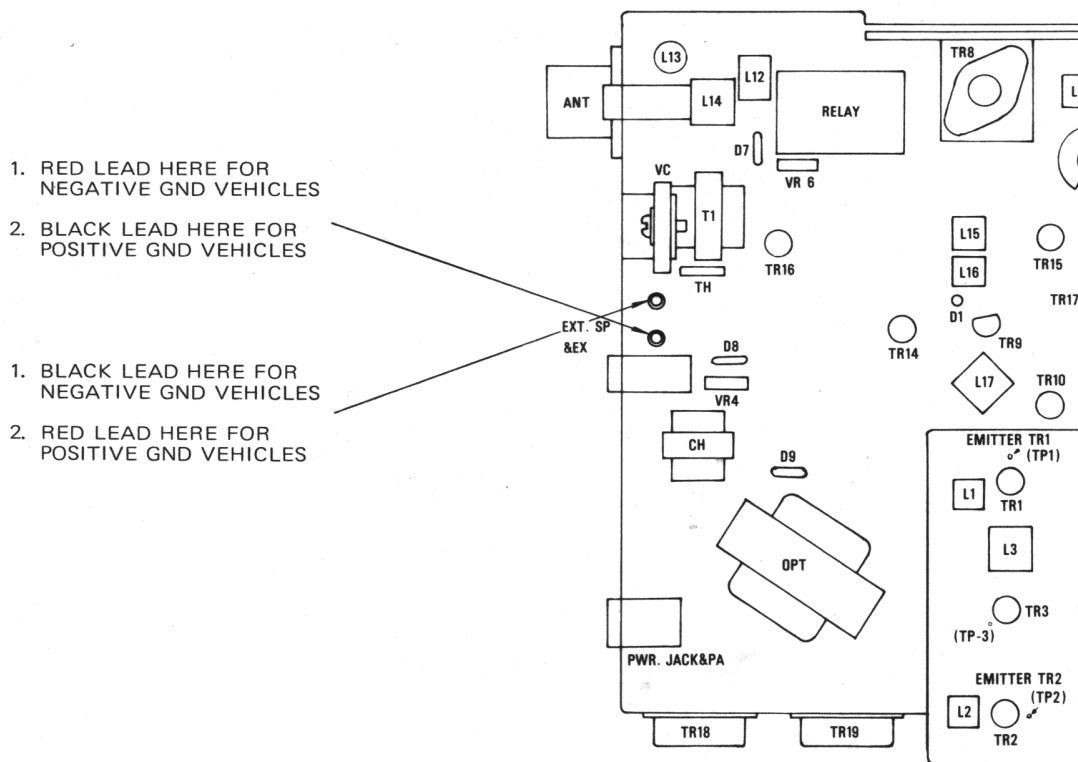

FIGURE 1

- Remove the chassis cover with caution because the speaker is connected directly into the unit by means of two leads terminated with push-type lugs.
- Refer to Figure 1 which shows the location of the two leads (red and black) which must be interchanged for positive ground operation. Each lead is attached to its terminal by a push-on type lug. To remove, simply pull steadily on the lug. Interchange the two leads as indicated in the diagram and push each lug down over its assigned terminal.
- Replace the chassis cover, making sure the speaker leads are properly attached to the speaker terminals and have not become loose.

Connect the DC power cord as follows: Connect the fused (red) lead to the vehicle "hot" point or source (in the case of positive ground vehicles this is the negative battery side). Connect the black lead to the vehicle chassis, or any other point that is connected to the chassis.

ATTACHING THE POWER CORD TO THE TRANSCEIVER

The plug at the end of the DC power cord is attached to the socket at the rear of the transceiver. Notice that the pins are unequally spaced, allowing the plug to be inserted only in one direction.

TRANSCEIVER MOUNTING

Before installing the transceiver in a car, truck, boat, etc., be sure to choose a location which is convenient to the operating controls, and will not interfere with the normal functions of the driver. The transceiver may be mounted to the underside of the instrument panel or dashboard of a car, truck, etc., by means of the special bracket that is supplied with the transceiver. Attach the bracket to the underside of the instrument panel using four self-threading screws (See Fig. 2). Secure the transceiver to the bracket by means of the large knurled thumbscrews the oval slot in the bracket will permit the unit to be tilted to a position which provides the operator with a better view of the front panel.

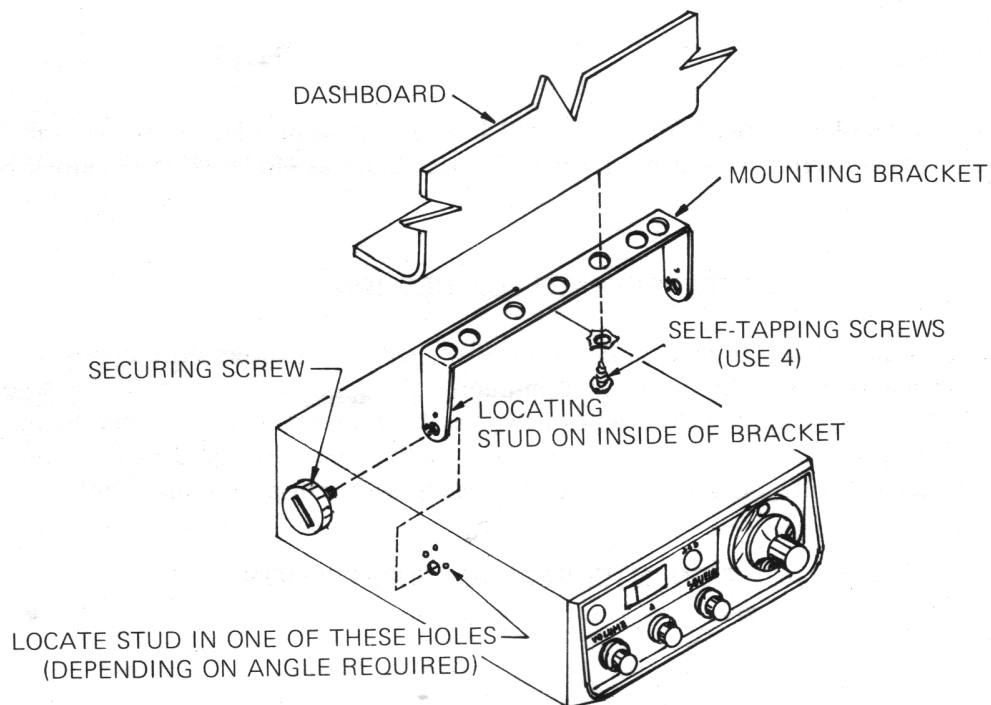

FIGURE 2. MOBILE INSTALLATION

MICROPHONE BRACKET

The small size of the HB-525E prohibits mounting a microphone bracket directly to the chassis. We recommend, therefore, that the microphone bracket be attached to the dashboard of the automobile or in any other convenient location. If one desires to do this without drilling holes, a magnetic mounting plate may be used and the microphone bracket attached to it.

MICROPHONE CONNECTION

Insert the 4-pin plug at the end of the coiled cord into the microphone socket at the side of the transceiver.

ANTENNA CONNECTION

The antenna lead-in cable (RG-58/U or RG-8/U) should be terminated with a PL-259 type male coaxial connector which should then be attached to the matching SO-239 connector at the rear of the transceiver.

AC POWER CONNECTION

As supplied, the HB-525E is designed to operate from a 12 volt DC battery source. For AC operation (house current), the solid-state power supply unit Model HB-502 is required.

The AC line cord from the power supply unit should be connected to an outlet supplying 105-120 volts 50/60 Hz AC.

6 VOLT DC OPERATION

The transceiver may also be operated from a 6 volt DC source by using a DC converter available for this purpose. This converter is available from Lafayette Radio as Model HB-505 (Stock No. 99-2084).

TV INTERFERENCE SUPPRESSION

This transceiver is equipped with a built-in series-resonant trap which offers little opposition to the transmitter output frequency but which will minimize any spurious emissions at the second harmonic (54 MHz). This trap, which is adjustable, has been preset at the factory to insure minimum TV interference, and should not require further adjustment. A procedure for adjusting the trap (when necessary) will be found in the section dealing with transmitter alignment.

AUTO IGNITION INTERFERENCE SUPPRESSION

AUTO

Your transceiver is equipped with a full-time Automatic Noise Limiter designed to provide efficient reduction of ignition noise. Ignition interference should not therefore be a problem in most cases. However, sufficient noise may be generated by some vehicles to make it necessary to install additional suppression. Several noise suppressor kits are available (such as Lafayette HP-204, Stock No. 42-0905) which include all necessary parts and instructions. Alternatively, you can take the vehicle to a skilled auto radio technician who will be able to carry out the suppression for you.

ANTENNAS

The results obtained with your new Lafayette Citizens Band Transceiver will be greatly determined by the efficiency of the antenna system used. Due to the complexity of the subject, it is not within the scope of this manual to provide detailed information on antenna systems. Although this section does contain some general information which may be of value to the beginning CB enthusiast, we suggest you purchase one of the numerous books available which covers this subject in greater detail. The Howard W. Sams publication by David E. Hicks, "CB Radio

Antenna Guidebook”, is particularly recommended. This book offers a complete guide to the selection and installation of CB antennas and includes a great deal of information that will be useful in obtaining optimum results with your antenna system.

MOBILE ANTENNAS

The type of antenna best suited for mobile service is a vertically polarized whip antenna. The vertical whip is non-directional and can be of the loaded type (top, center or base loaded), or a full quarter-wave, the latter usually being more efficient. Both types use the metal body of the vehicle as a “ground plane”. There are a number of locations that may be used for the installation of an antenna on a car. Four of the most popular locations are those shown in Figure 3.

FRONT COWL MOUNTING

Front cowl mounting offers a number of advantages. The CB antenna can be mounted in place of the regular auto radio antenna and will thus provide the minimum of installation problems. The antenna can then be used for both the CB and standard auto radio by employing any of the commercially made two-way couplers available (such as the Lafayette HP-202, Stock No. 42-0903). In this location you can install a short loaded whip, with only a small loss of efficiency.

The horizontal radiation pattern in such a location is slightly irregular, radiation being slightly greater in the direction of the rear fender opposite to the side on which the front cowl antenna is mounted.

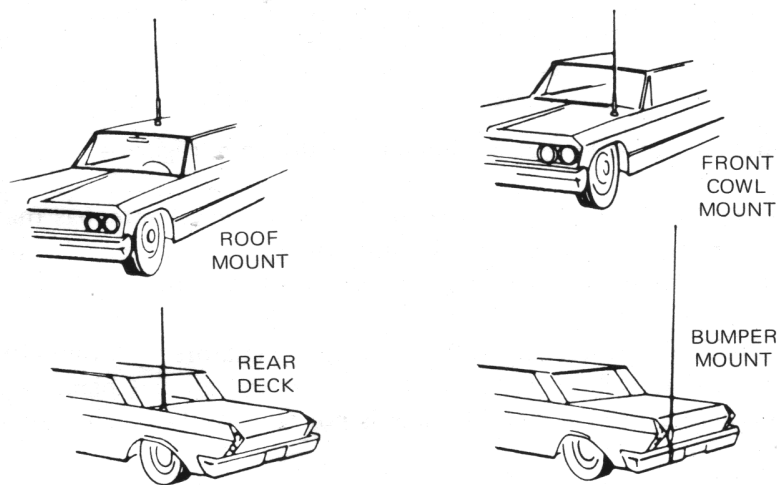

FIGURE 3.

ROOF MOUNTING

Roof mounting is actually the best location because it provides an almost perfect omnidirectional radiation pattern. However, even the use of a shorter loaded whip on the roof of a vehicle is impractical in this location.

REAR DECK MOUNTING

Rear deck mounting permits the use of a full quarter-wave antenna or a shorter, loaded whip. The radiation pattern in such a location is somewhat irregular, radiation being slightly greater in the direction of the front fender opposite to the side on which the rear deck antenna is mounted.

BUMPER MOUNTING

This arrangement uses the rear bumper of the car and is by far the most practical for use with full 108-inch quarter-wave whips. Another advantage is that removal of the antenna is simple and leaves no holes in the car body. The radiation pattern produced by an antenna mounted on the left rear bumper is fairly irregular, with greatest radiation being in two directions – one to the right and forward slightly, the other to the rear and left slightly.

BASE STATION ANTENNAS

SHORT RANGE

The Lafayette HE-19 (Lafayette Stock No. 99-3015) is a small base loaded whip designed for short range communications work – intercommunication between buildings, etc. It mounts directly in the back of the transceiver. Extended, it measures 45”, closed 15”.

LONG RANGE

There are three basic types of long-range antennas as shown in Figure 4.

1. Vertical Ground Plane Antennas. These are omnidirectional antennas that provide optimum performance for contacting other fixed stations using vertical type antennas in addition to all mobile stations. For medium-long range communications work.
2. Coaxial Antennas. These are high efficiency type radiators with omnidirectional characteristics, performing as well in most applications as the ground plane type. Ideal for those installations where a vertical ground plane is not feasible. For medium-long range communications work.

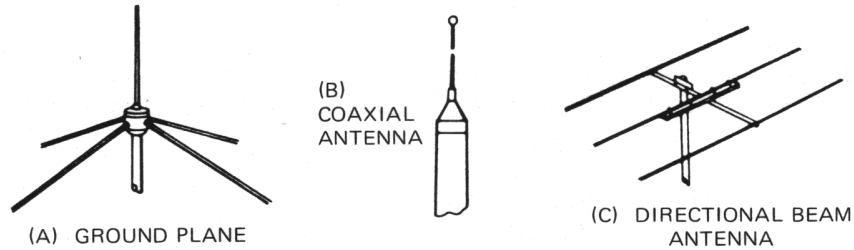

FIGURE 4.

3. Directional Beam Antennas. Highly efficient and directional antennas generally intended for fixed-to-fixed long range communications. An average three-element beam provides an equivalent of 8 db increase in transmitter power.

OPERATING INSTRUCTIONS

NEVER ATTEMPT TO TRANSMIT WITHOUT AN ANTENNA CONNECTED TO THE TRANSCEIVER.

Make sure the transceiver is properly installed for base or mobile operation (as indicated previously) and that the antenna and power source are connected. If you have not already done so, plug in the microphone.

RECEIVING

Rotate squelch control to the extreme counter-clockwise position, and select desired channel. Rotate the volume control knob until the switch operates. Advance the volume control to about 1/3 setting. Since the transceiver is fully transistorized, operation will be instantaneous. Adjust to a comfortable listening level. The receiver is now ready to operate.

SQUELCH ADJUSTMENT

The Squelch control is used to eliminate any annoying background noise when no signals are present. To adjust the SQUELCH control properly during reception, turn up SQUELCH until background noise just disappears. At this point, the receiver will be quiet under "no-signal" conditions, but an incoming signal will overcome the squelch action and be heard. Since this control is variable, it can be used to provide varying degrees of sensitivity to incoming signals. As the control is advanced (from counter-clockwise position), the squelch action is progressively increased and progressively stronger incoming signals are needed to overcome it. To receive extremely weak signals or to disable the squelch circuit, simply turn the control fully counter-clockwise.

NOTE: In areas of high noise, you may have to slightly increase the setting of the Squelch control in order to achieve a "quiet" condition. However, under these conditions an extremely weak signal may not be able to overcome the squelch action and will not be heard. If severe noise is generated by your own vehicle, proper vehicle ignition suppression should be carried out.

DELTA TUNING

The ▲ TUNE control acts as a “fine tuning” control (± 2 KHz) and may be used for reception of a station that is slightly off-frequency. Try all position and select the one that provides best reception.

IMPORTANT NOTE: When better reception is obtained with the ▲ TUNE control in either the plus or minus position, there is always the possibility that the station you are receiving is actually on an adjacent channel. While this is not usual, it can occur when the received station is off frequency or when the incoming signal is of sufficient strength to overcome the normal high selectivity of the receiver. To determine whether you are actually tuned to the correct channel, simply switch to each adjacent channel in turn, and note whether better reception (and higher “S” reading) is obtained with the ▲ Tune switch in the normal (center) position.

EXT. SP JACK

The recommended plug for this jack is a “TINI-PLUG” subminiature phone plug, available from Lafayette under catalog number 34-6031. The impedance of earphones or speakers connected to this jack should be 16 ~ 32 ohms. Insertion of a plug into the jack automatically silences the internal speaker.

TRANSMITTING

Before operating the transmitter the following **MUST** be done:

1. A valid Class “D” Citizens Band equipment license shall be posted at the main control (fixed) station location.
2. A properly filled out and SIGNED mobile identification card, 452C, must be affixed to the unit.
3. Rules Part 95 must be obtained, read and understood.

To transmit, depress the push-to-talk button on the microphone. The channel indicator dial light will go out and a colored lamp on the front panel will light up, indicating that you are on the air. Hold the microphone 3 to 5 inches from the mouth and slightly to one side so that the voice does not project directly into the microphone (this provides best results). Speak at a normal level – **NEVER RAISE YOUR VOICE OR SHOUT INTO THE MICROPHONE**. A design feature of this transceiver is that high average modulation can be achieved easily at normal voice levels.

During periods of transmission, the receiver is silenced and reception is therefore impossible. In the same way, your signal cannot be heard by another station when he is transmitting -- each must take turns. To receive again, simply release the microphone push-to-talk button.

NOTE: If you are using the HB-502 AC power supply, you may observe a slight “flickering” of the transceiver dial light during transmit. This is normal and should be disregarded.

AUX OPERATION

The impedance at the EX jack is 100K ohms. Input levels of 300 millivolts will produce full output and can be controlled by the VOLUME control. SQUELCH control should be turned to the fully counter clockwise position.

PUBLIC ADDRESS OPERATION

Special provision has been made for Public Address (PA) operation, utilizing the microphone and audio stages in the transceiver. For PA operation, you should use an external 16-32 ohm speaker connected to the "PA" jack. Use Lafayette catalog No. 34-6031 jack. Set the channel Selector to PA, press the push-to-talk button on the microphone and talk into it – your voice will be heard from the external speaker (which may be mounted on the exterior of a car or building). NOTE: As soon as the microphone push-button is released, the transceiver will return to the normal receive mode to provide CB reception. Note also that the Volume control on the transceiver does not control the speaker output when microphone push-to-talk switch is depressed.

OPERATING PROCEDURES

A Citizens Band station is NOT intended to be a replacement for a ham station. Transmission of a "CQ" (calling any station) to alert any station that might be listening is in violation of Citizen Band Regulations (except in an emergency). For information on permissible types of communications, you should always refer to Part 95 of the FCC Rules and Regulations.

When a licensed system consists of several mobile units (cars, boats, etc.), it is common practice to designate the control station by the assigned call letters and arbitrarily assign numbers to the mobile units. An example of a typical exchange might then be as follows:

Station 1... "This is 2W9374, unit one calling unit two mobile."
Station 2... "2W9374 unit one, this is 2W9374 unit two, 10-2 over."
Station 1... "What is your 10-20 unit two?"
Station 2... "10-20 is Elm and Maple Streets."
Station 1... "Proceed to service call at 999 Market Street. 10-4?"
Station 1... "2W9374 unit one is clear."

For convenience, the National "10-Code" is listed as follows:

GENERAL PROCEDURE

- | | | | |
|---------|---------------------------------------------------------|---------|-----------------------------------------|
| 10 - 1 | Receiving poorly | 10 - 14 | Correct time |
| 10 - 2 | Signals good | 10 - 15 | Make a pickup of at |
| 10 - 3 | Stop transmitting -- channel in use by others | 10 - 16 | Have picked up or have in possession |
| 10 - 4 | OK -- affirmative -- message received | 10 - 17 | Urgent (business) |
| 10 - 5 | Relay message | 10 - 18 | Anything for us |
| 10 - 6 | Operator busy, stand by | 10 - 19 | Nothing for you -- return to station |
| 10 - 7 | Out of service | 10 - 20 | What is your location? |
| 10 - 8 | In service -- subject to call | 10 - 21 | Call me by landline |
| 10 - 9 | Repeat transmission -- poor reception | 10 - 22 | Report in person to |
| 10 - 10 | Transmission completed -- subject to call (standing by) | 10 - 23 | Stand by |
| 10 - 11 | Speaking too rapidly | 10 - 24 | Finished with last assignment |
| 10 - 12 | Officials or visitors present | 10 - 25 | Do you have contact with |
| 10 - 13 | Advise road and weather conditions | 10 - 26 | Disregard last information |
| | | 10 - 27 | Moving to channel |

EMERGENCY OR UNUSUAL

- 10 - 30 Does not conform to rules and regulations
- 10 - 33 Emergency traffic at this station
- 10 - 34 Trouble at this station, help needed
- 10 - 35 Confidential information
- 10 - 36 Accident at
- 10 - 37 Wrecker needed at
- 10 - 38 Ambulance needed at
- 10 - 39 Convoy or escort
- 10 - 70 Fire
- 10 - 79 Report progress of fire

TECHNICAL

- 10 - 91 Too weak, talk closer to mic
- 10 - 92 Too loud, talk farther from mic
- 10 - 93 Frequency check
- 10 - 94 Give a test: J1 with voice -- J2 without voice (carrier)

TRANSMITTER IDENTIFICATION CARD

When you have received your license, you are required to fill out the Transmitter Identification Card, FCC Form 452-C which has been supplied. Fill out the card as indicated and attach to the outside of the transceiver.

1. Enter your call sign which is on the left hand corner of your license. The unit designation should agree with the number of stations licensed to you.
2. Enter the name of the licensee.
3. Enter here the home address of individual or address of business if license is kept at a business location.
4. Already answered.
5. The date of expiration on the license should be entered here.
6. Sign the card in this space.

SERVICE AND ALIGNMENT

As an aid to the service technician, this manual contains a layout diagram identifying transistors, transformers, coils, etc., a schematic diagram with voltages, and a functional block diagram. Also included are instructions for aligning the receiver and transmitter sections.

RECEIVER ALIGNMENT

To align the receiver portion of the HB-525E transceiver refer to the layout diagram for location of alignment points and proceed as follows:

455 KHz IF ALIGNMENT

1. Connect signal generator to anode of D2.
2. Connect AC VTVM to speaker terminals.
3. Set signal generator to 455 KHz \pm 1 KHz.
4. Apply power to unit and adjust signal generator output to produce a reading of 0.5 volts on the AC VTVM.
5. Adjust mechanical filter (MF), L20, L22 and L23 for maximum output on VTVM.

NOTE: Reduce output of signal generator as necessary to keep VTVM reading around 0.5 volts.

11.275 MHz IF ALIGNMENT

1. Connect signal generator to base of transistor TR-10.
2. Connect AC VTVM to speaker terminals.
3. Set signal generator to 11.275 MHz. (\pm 1 KHz)

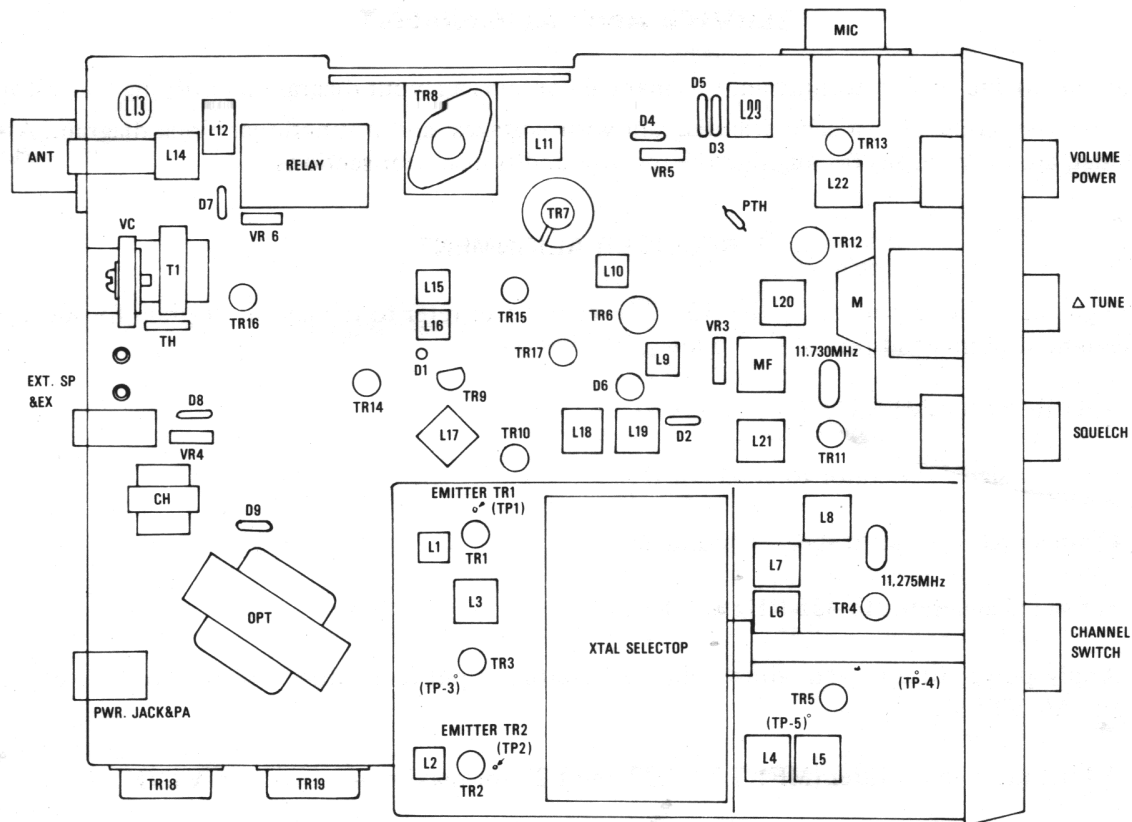

4. Adjust L18 and L19 for maximum output as read on VTVM. Reduce signal generator output as necessary to keep the VTVM reading around 0.5 volts.

CAUTION: All coil cores in this unit have been sealed with wax. Before attempting to adjust each core, be sure to melt the wax so as to permit free movement. Failure to do this may result in damaged cores.

LOCAL OSCILLATOR ALIGNMENT

1. Connect a DC VTVM between the emitter of TR-1 (TP-1) and ground.
2. Adjust the core of L1 to the bottom of the coil (maximum inductance).
3. Turn core of L1 in a counter-clockwise direction until the local oscillator begins to oscillate. This will be indicated by a reading on the VTVM.
4. Turn core two more turns in a counter-clockwise direction. VTVM should now read approximately + 2.5 volts.

SYNTHESIZER OSCILLATOR ALIGNMENT

1. Connect a DC VTVM between the emitter of TR-2 (TP-2) and ground.
2. Adjust the core of L2 to the bottom of the coil.
3. Turn the core of L2 in a counter-clockwise direction until the oscillator begins to oscillate. This will be indicated by a reading on the VTVM.
4. Turn core two more turns in a counter-clockwise direction. VTVM should now read approximately + 1.3 volts.

RF ALIGNMENT (Place delta tune switch in center position)

1. Connect signal generator to antenna connector.
2. Connect AC VTVM across speaker terminals.
3. Set signal generator to 27.115 MHz, modulated 30% with a 1 KHz tone. Set signal generator output to 10 μ V.
4. Set transceiver to channel 13 and vary signal generator frequency around 27.115 MHz to produce a maximum reading on the AC VTVM.
5. Adjust L15, L16 and L17 to produce maximum output on AC VTVM.
6. Reduce generator output to approximately 1 μ V. Adjust L3, L4, L5, L15, L16, L17, L18, L19, MF (mechanical filter), L20, L22, and L23 for maximum reading on VTVM.

SQUELCH ADJUSTMENT

1. Connect signal generator to antenna connector.
2. Set squelch control to the maximum clockwise position.
3. Set signal generator output to 10 mV. Adjust potentiometer VR-3 for opening the squelch.

TRANSMITTER ALIGNMENT

OSCILLATORS

The synthesizer and local oscillators are used for both receive and transmit functions of the transceiver. These oscillators have already been adjusted during alignment procedures for the receiver and thus require no further alignment.

ALIGNMENT PROCEDURE

1. Connect a 50 ohm wattmeter to the antenna connector on the transceiver.

2. Set transceiver channel selector to 13.
3. Apply power to transceiver (12.6 volts DC). Depress microphone button and adjust cores of L6, L7, L8, L9, L10 and L11 for maximum on VTVM.

NOTE: Adjustment of L10 is fairly critical. Misadjustment of this coil can reduce the transmitter output to zero.

4. Check power output on all channels. If low on some channels, readjust L6, L7, L8, L9, L10 and L11 for equal output on channels 1 and 23. This will usually ensure equal output on all 23 channels.
5. Adjust L12, L13 and VC for maximum output on the wattmeter.

NOTE: L12 is adjusted by either compressing or expanding the coil turns. Use a non-metallic tuning tool to spread the wire turns.

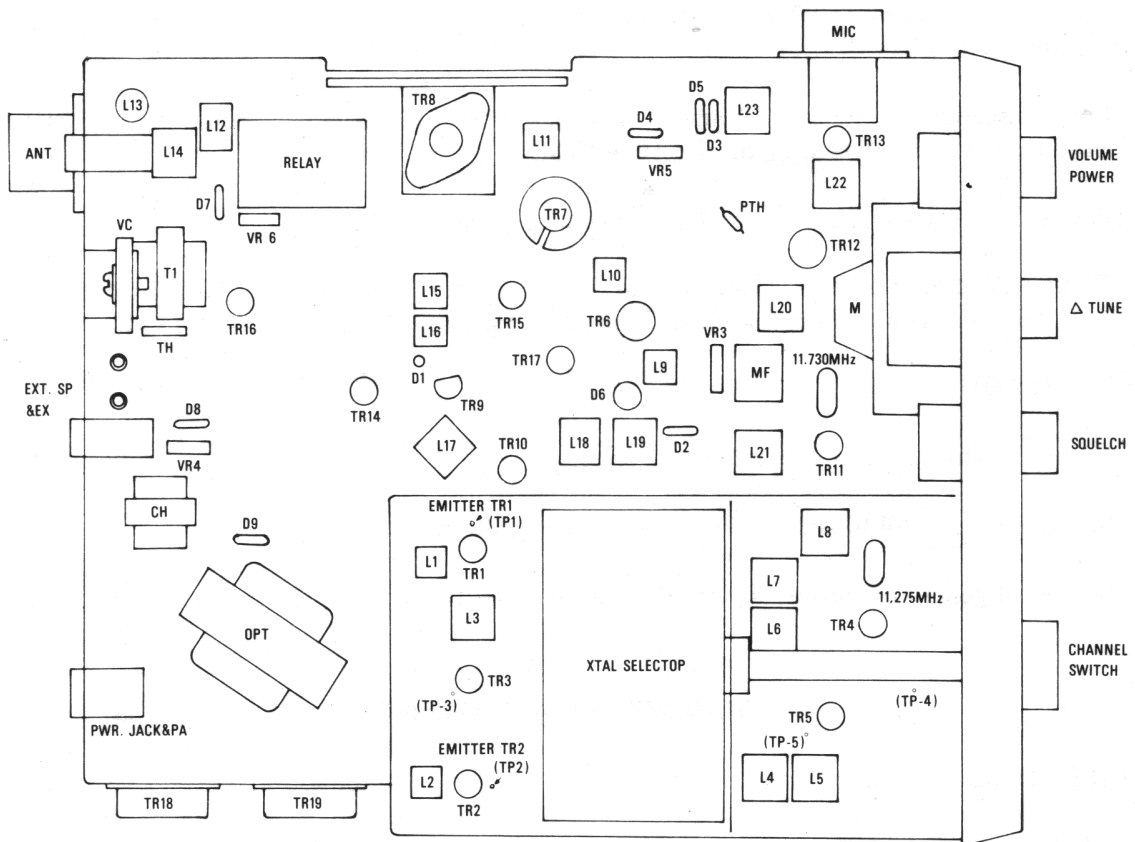

6. The transceiver may be peaked for maximum RF power output at the actual installation with the antenna connected by re-adjusting VC for maximum radiated power on an RF field strength meter.

MODULATION ADJUSTMENT

1. Connect a modulation monitor to the transceiver.
2. Connect an audio generator between ground and the center pin on the microphone connector on the transceiver. Set generator frequency to 1 KHz and adjust output level to 10 mV.
3. Apply power to transceiver and depress microphone button. Adjust potentiometer VR-4 to produce 80% modulation as indicated by the modulation monitor.

NOTE: Following above steps will produce 100% modulation on voice signals. In no case shall the modulation exceed 100%.

TVI ADJUSTMENT

1. Use a TV receiver set to channel 2 as an indicator.
2. Depress transceiver microphone button and adjust L14 (rear of transceiver) for minimum interference on TV receiver.

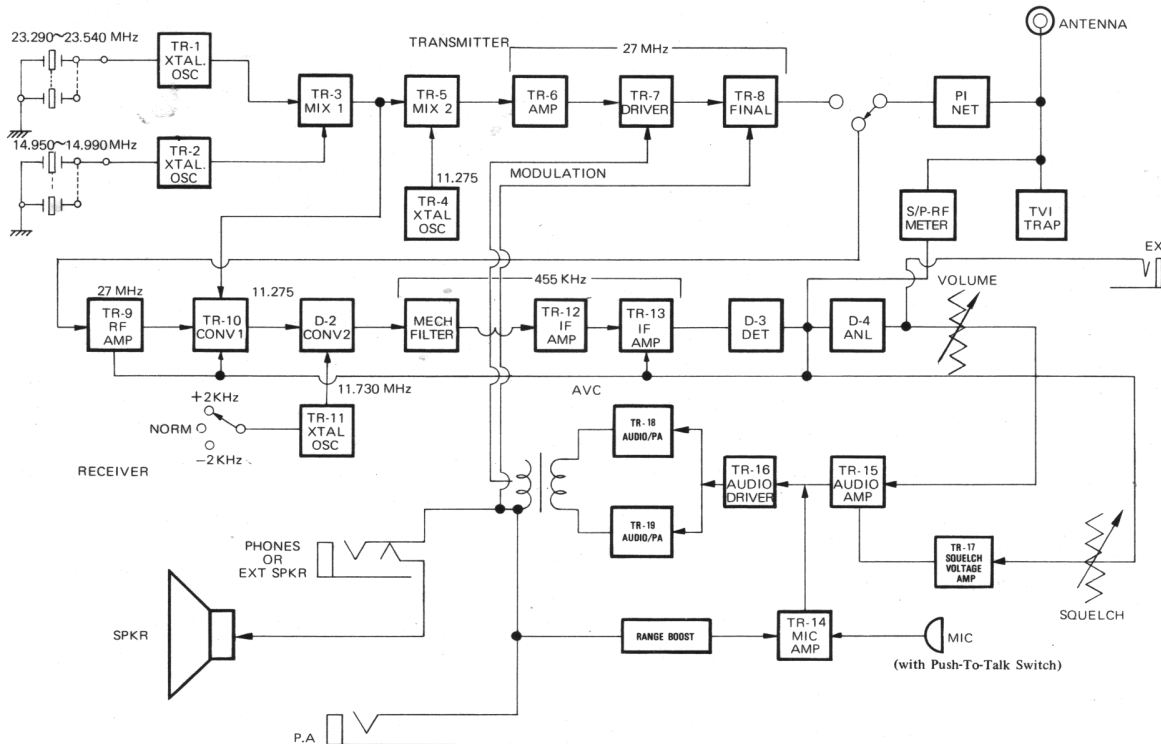

FUNCTIONAL BLOCK DIAGRAM

RETURNING THE UNIT FOR REPAIR

If you wish to return the unit for repair (either in or out of warranty), we recommend that you return the transceiver to the Lafayette store from which it was purchased. If the unit is to be shipped to our main office for service, please read the instructions which follow.

SHIPPING INSTRUCTIONS

Pack the unit very carefully to avoid damage in transit, preferably in its original carton. If the original carton is not available, use a sturdy carton with least 3 inches of shredded paper or excelsior around the unit. In the latter case, wrap the unit in paper first to avoid particles of packing material getting into it. Include with the unit a letter explaining exactly what difficulties you have encountered [remember to add extra First Class postage and indicate on the outside of the carton that First Class-Mail is enclosed]. Ship by prepaid express if possible and mark ELECTRONIC EQUIPMENT – FRAGILE. Clearly address the carton as follows:

SERVICE DIVISION
LAFAYETTE RADIO ELECTRONICS CORP.
150 Engineers Road
Hauppauge, L.I., N.Y. 11787

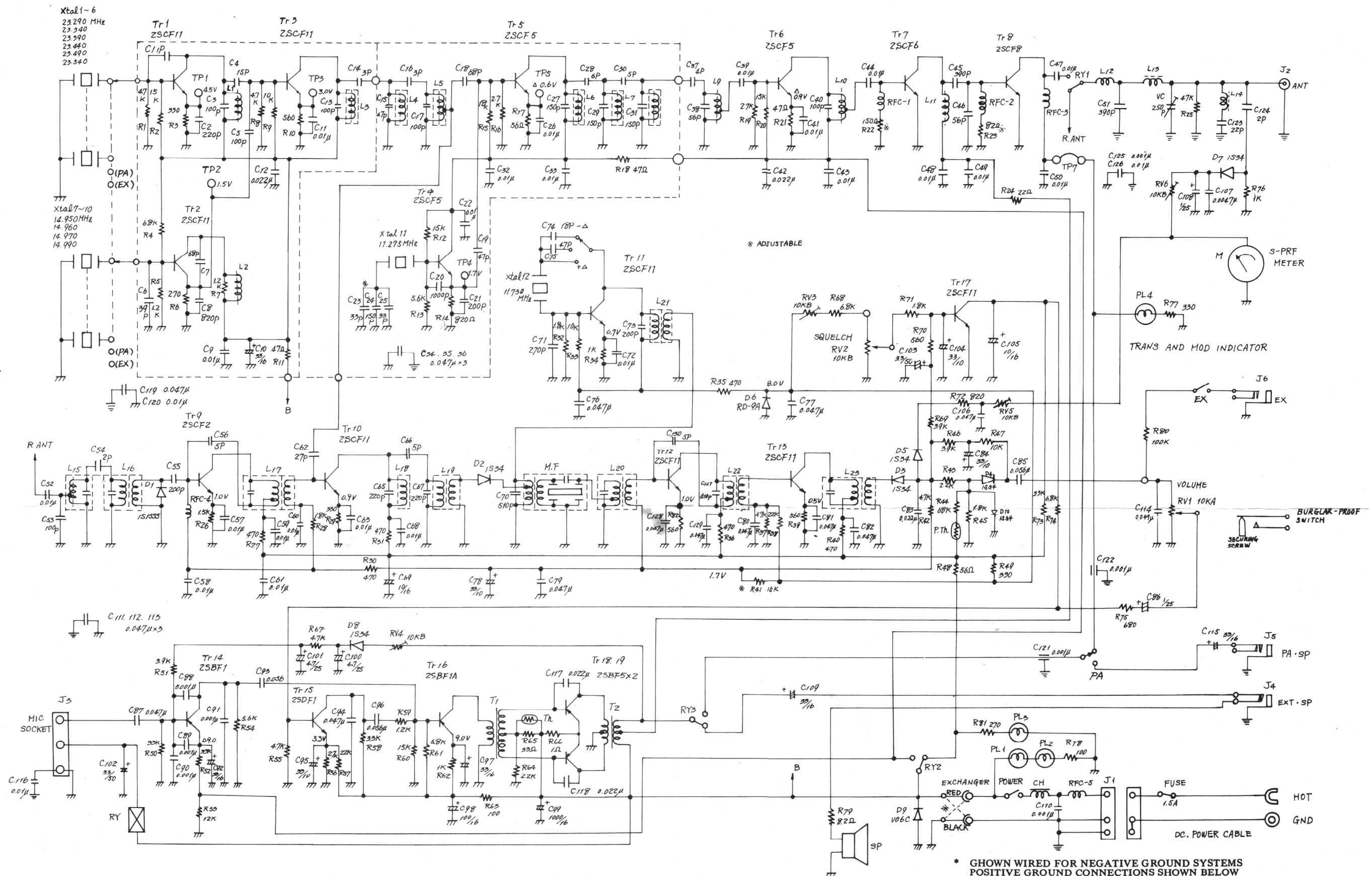

- * All measurements are D.C. and obtained with NO SIGNAL INPUT and volume controls at extreme minimum position.
- * All measurements obtained using Tester (Impedance: Higher than 20,000 ohms)
- * All measurements are relative to chassis ground.
- * All unmarked polarity measurements are positive to chassis ground.
- * If measurements obtained are in excess of plus/minus 20 percent of values shown then reason for difference should be corrected.
- * Δ VOLTAGE DURING TRANSMIT

LAFAYETTE HB-525E CB TRANCEIVER

Printed in Japan
II-Jan./1971

* SHOWN WIRED FOR NEGATIVE GROUND SYSTEMS
POSITIVE GROUND CONNECTIONS SHOWN BELOW

