



OWNER'S MANUAL



**Model KCB-4000
40 Channel Mobile
CB Transceiver**

FOR UNDER-DASH INSTALLATION

introduction

Your new KCB-4000 Citizens Band Transceiver is a 40 Channel, 4 Watt unit designed for mobile use and approved for Class "D" licensed operation. For maximum enjoyment of your new transceiver and for many years of troublefree operation, read your owner's manual carefully before installing or operating this unit.

controls

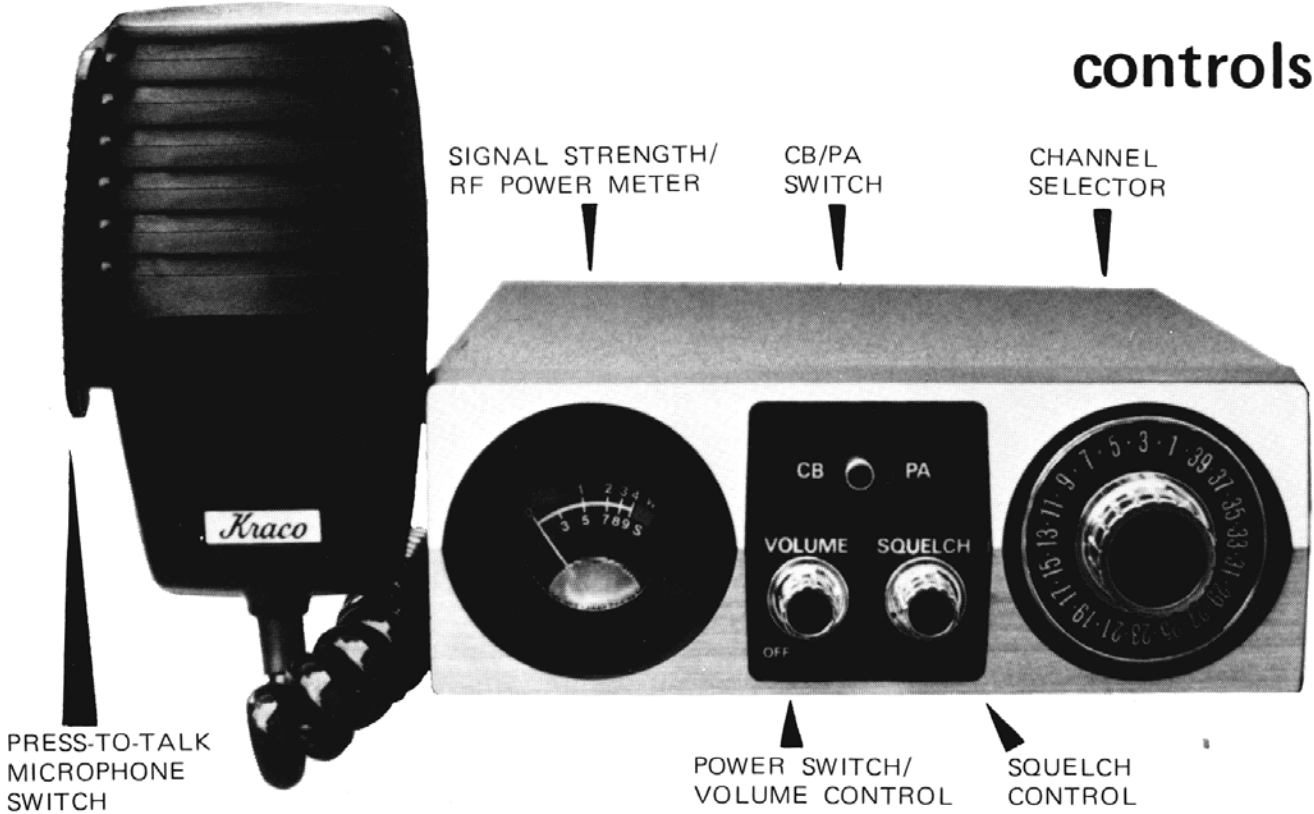

rear panel features

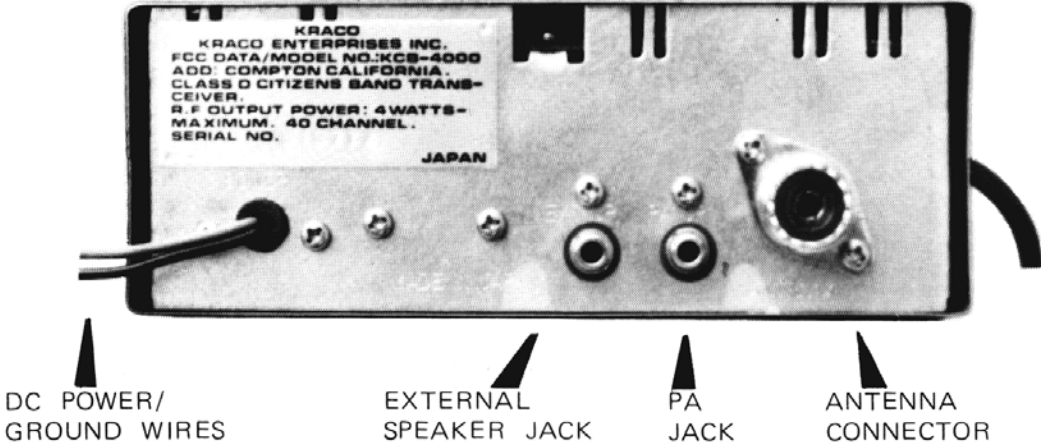

control functions

POWER SWITCH/VOLUME CONTROL

This control operates conventionally; rotate knob clockwise to turn power on and to increase volume. Transmit power is not affected by the volume control.

SQUELCH CONTROL

This control is used to eliminate high frequency background noise during CB reception (see CB Operation).

CB/PA SWITCH

Select CB or PA (Public Address) function.

CB CHANNEL SELECTOR

With this control you can select any of the 40 CB channels. The illuminated area at the top of the dial indicates the channel selected.

S/RF METER

This dual function meter indicates relative signal strength (lower scale) during CB reception, and relative output power (upper scale) while transmitting.

MICROPHONE SWITCH

“Press-To-Talk” in both CB and PA mode. Release switch when receiving CB broadcasts.

inputs/outputs

EXTERNAL SPEAKER JACK

Accepts standard mini-plug for 8 ohm external speaker or earphone (not supplied).

PA JACK

Accepts standard mini-plug for 8 ohm PA speaker (not supplied).

DC POWER/GROUND WIRES

(See Electrical Connections)

ANTENNA CONNECTOR

Accepts standard PL-259 coaxial antenna plug (see Electrical Connections).

CB operation

F.C.C. REQUIREMENTS

This transceiver is designed for use under F.C.C. Rules and Regulations, Vol. VI, Part 95 and you are prohibited from operating this transceiver until you obtain your Citizens Band Class D License. This license is obtained by filing Application Form 505 (supplied with the unit) with the F.C.C. along with the proper filing fee. You are also required to read and understand Part 95 of the F.C.C. Rules and Regulations and all licensees are required to maintain an up-to-date copy of these rules. Subscription(s) must be filed with the Superintendent of Documents, Government Printing Office, Washington, D. C. 20402.

Adjustments to the transmitter circuit of the transceiver may be made only by or under the supervision of a person holding a current commercial first or second class radio operator license. Replacement or substitution of crystals, transistors or other components must be made only by components supplied by KRACO ENTERPRISES INC., 505E. Euclid Ave., Compton, Ca 90224.

Preparing to Transmit or Receive:

- Make sure that a proper CB antenna is attached.
Select CB mode with the CB/PA Switch.

TO RECEIVE

1. Turn the Power Switch on and increase the volume slightly.
2. Select a CB station with the 40 channel CB Selector Knob.
Note: CB Emergency calls may be monitored on Channel 9.
3. Increase volume to a comfortable listening level, then adjust the Squelch Control.
Squelch Adjust: During a time when only background noise is present on the station, rotate the Squelch Control knob slowly clockwise just until background noise disappears.

TO TRANSMIT

Hold the microphone three to four inches from your lips.
Press the button on the side of the microphone while talking.
Speak in a normal voice directly into the microphone.

Remember to release the microphone button to receive.

Note: Transmit emergency calls on Channel 9 only.
(You may use an other channel if Ch. 9 is busy or if there is no response).

TO OPERATE PA

Note: For PA operation, an 8 ohm PA Speaker (not supplied) must be plugged into the PA Jack at the rear of the unit. To adjust volume a separate volume control (not supplied) must be connected to the PA Speaker. The volume control on the KCB-4000 does not affect public address operation.

1. Turn the Power Switch on and increase the volume slightly, using the separate volume control for the PA Speaker.
2. Press the button on the side of the microphone while talking. Speak directly into the microphone and adjust PA Speaker volume control as desired.

installation

CHOOSING A MOUNTING LOCATION

Choose a location for the transceiver so that the controls are within easy reach of the driver. Make sure that the location does not in any way interfere with driving. A special bracket is supplied to provide easy mounting to the underside of the dash as shown below. The bracket can also be inverted for floor or console mounting.

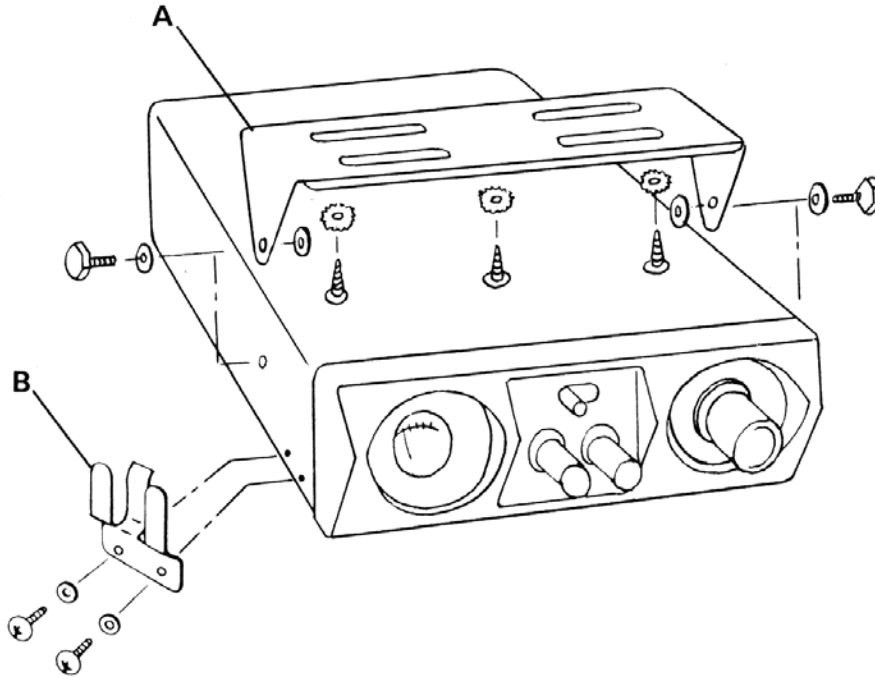

1. Using Bracket A as a template, mark the locations of the holes to be drilled.
MAKE SURE THAT THE AREA TO BE DRILLED IS CLEAR OF WIRES OR OTHER OBSTRUCTIONS BEHIND THE PANEL.
2. Drill three or four 5/32" dia. holes (at least three).
3. Attach Bracket A to vehicle panel, using the large self-tapping screws and lockwashers supplied.
4. Attach Microphone Hanger B to either side of the transceiver with two small self-tapping screws and washers supplied (holes are pre-drilled in the transceiver).
5. Secure the transceiver to Bracket A with hex head screws and washers as indicated in the figure.
6. Secure all electrical connections (overleaf).

electrical connections

Before operating the transceiver you must connect a proper antenna system. Operating the transceiver without an antenna or a 50 ohm dummy load may cause damage to the expensive RF power transistors.

The antenna is one of the most important factors in the operation of the transceiver at its full efficiency. The choice of CB antenna type and mounting method will largely depend on the type of vehicle, mounting location, etc. We recommend you consult either with the dealer from whom you purchased the transceiver, or any other CB/Amateur radio supply shop; they will meet your specific needs.

Note: THIS UNIT IS FOR USE ONLY WITH A 12 VOLT DC NEGATIVE OR POSITIVE GROUND ELECTRICAL SYSTEM.

To determine the type of electrical system in your vehicle, inspect the battery. The battery should appear as shown:

To determine polarity, look for Positive (+) or Negative (-) mark near or on top of the ground terminal post. The ground terminal post is also usually slightly larger than the 12 V terminal post.

A 12 VOLT BATTERY (EXCEPT FOR SEALED TYPE) HAS 6 FILLER CAPS

GROUND CABLE
(ATTACHED TO ENGINE
BLOCK OR METAL BODY
STRUCTURE)

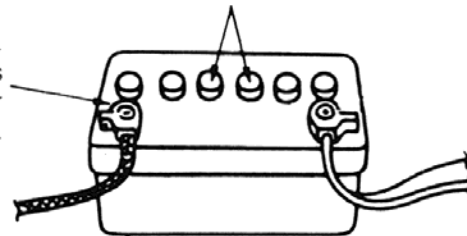

12 V. CABLE
(ATTACHED TO STARTER
MOTOR AND VOLTAGE
REGULATOR)

If you are not certain of the polarity of the electrical system of your car, please consult with your automobile dealer.

CAUTION: TO AVOID POSSIBLE INJURY AND TO PREVENT DAMAGE TO YOUR TRANSCEIVER OR TO YOUR AUTOMOBILE, DISCONNECT BOTH CABLES AT THE BATTERY TERMINALS BEFORE PROCEEDING WITH ANY OF THE FOLLOWING INSTRUCTIONS.

TURN UNIT OFF BEFORE MAKING
ELECTRICAL CONNECTIONS.

NEGATIVE GROUND SYSTEM

1. Connect the BLACK lead from the transceiver to the metal chassis ground of the vehicle.
2. Connect the RED (fused) lead from the transceiver to any convenient Positive (hot) side of the electrical system.

POSITIVE GROUND SYSTEM

1. Connect the RED (fused) lead from the transceiver to the metal chassis ground of the vehicle.
2. Connect the BLACK lead from the transceiver to any convenient Negative (hot) side of the electrical system.

Note: The accessory terminals on the ignition switch are often used so that power to the transceiver can be turned off or on with the ignition key.

specifications

GENERAL

Circuitry	24 Transistors, 1 IC's, 19 Diodes, 2 Vari-Cap, 1 Zeners
Frequency Control	P.L.L. (Phase Locked Loop) Frequency Synthesizing System
Channels	40 Channels Installed
Mode of Operation	AM
Power Source Voltage	13.8 V DC
Speaker	3" Dynamic, 8 ohm
Microphone	Dynamic 500 ohm

RECEIVER SECTION

Receiving System	Dual Conversion System
Sensitivity	0.7 uV for 10 dB S/N
Selectivity	More than 45 dB down at +10 KHz
Spurious Rejection	-45 dB (except image)
Audio Output Power	3.0 Watts at 8 ohms
Squelch Range	0.7 uV to 300 uV
IF 1st	10.695 MHz
2nd	455 KHz

TRANSMITTER SECTION

Modulation System	High Level Class B
RF Output Power (at 13.8 V)	4 Watts (F.C.C. Maximum)
Frequency Tolerance	$\pm 0.005\%$
Spurious Rejection	Exceeds -60 dB

Limited Warranty

This warranty gives you specific legal rights, and you may also have other rights which vary from state to state. Kraco warrants this product to be free from defects in material and workmanship under normal use and service. This warranty is limited to the replacement of defective parts, provided that defect occurs within 90 days from date of purchase and provided that product is returned immediately to Kraco. We will repair free of charge replace at no charge any unit which our examination shall disclose to be defective and under warranty. This warranty shall be valid only when a purchaser has filled in and has on file at the factory a warranty registration card. If no warranty card is on file, a sales receipt showing the date of purchase must accompany the article being returned.

The provisions of this warranty shall not apply to any part which is used for a purpose for which it is not designed nor which shall have been repaired or altered in any way so as to affect adversely its performance and reliability; nor shall this warranty apply to any part which has been subject to misuse, neglect or accident.

Kraco does not authorize any other person to assume any other liability in connection with its product and the implied warranty of merchantability and fitness as limited to the duration of this warranty.

Your unit will be serviced on an in-warranty basis within the guarantee period for the correction of warranted defects if the unit is returned postage prepaid and packaged in the original shipping carton with \$5.00 to cover handling, return postage and insurance. Please send a check or money order only-no stamps. Do not return the unit to your dealer. Return your unit with a description of the problem to:

Kraco Warranty Department, 505 East Euclid Avenue, Compton, California, 90224

To Return Units Out of Warranty: Return the unit postage prepaid, packaged in the original shipping carton. Include in the package a description of the problem and if desired, a request for an estimate of repair costs. Unless a request for an estimate is included, the unit will be repaired as necessary. \$20.00 (labor) plus parts, will be charged for repairs to all CB units and CB combination units. The repaired unit will be returned to the customer with an itemized bill, C.O.D.

Owner's Record

Model Number _____

Serial Number _____

Purchase Date _____

Purchased From _____