

SERVICE MANUAL SERVICE MANUAL

SERVICE MANUAL 29 PLUS



DELUXE MOBILE CB RADIO with ELECTRONIC TUNING
7-SEGMENT BAR GRAPH MULTI-FUNCTION METER
"DYNA-MIKE" and CHANNEL SAVER
PUSHBUTTON DIRECT/INSTANT TUNING of CHANNELS 9 and 19

 **Cobra**[®]

CONSUMER ELECTRONICS GROUP
DYNASCAN CORPORATION
6500 WEST CORTLAND STREET
CHICAGO, ILLINOIS 60635

TABLE OF CONTENTS

SPECIFICATIONS	3
BLOCK DIAGRAM	5
CIRCUIT DESCRIPTIONS	6
PHASE LOCK LOOP	6
PLL CIRCUIT	6
CIRCUIT FOR PREVENTION OF UNAUTHORIZED FREQUENCY EMISSION	7
RX OPERATIONS (Refer to block and schematic diagrams)	9
TX OPERATION (Refer to block and schematic diagrams)	9
PA OPERATION	9
CHANNEL 9 CIRCUIT	9
ALIGNMENT PROCEDURE	10
TROUBLESHOOTING HINTS	14
PLL CIRCUIT TROUBLESHOOTING HINTS	16
ADDITIONAL PARTS ON THE BOTTOM	17
MAIN P.C. BOARD (TOP VIEW)	18
MAIN P.C. BOARD (BOTTOM VIEW)	19
FRONT P.C. BOARD (TOP & BOTTOM)	20
LED P.C. BOARD (TOP & BOTTOM)	20
WIRING DIAGRAM	22
COPPER PATTERN LAYOUT	23
ELECTRICAL PARTS LIST	24
MECHANICAL PARTS LIST	36
VOLTAGE CHART	35
TRANSISTOR VOLTAGE CHART	38
IC VOLTAGE CHART	40
SEMI-CONDUCTOR LEAD IDENTIFICATION	42
IC INTERNAL DIAGRAMS	43
EXPLODED VIEW	37
SCHEMATIC DIAGRAM	46

SPECIFICATIONS

GENERAL

Channels	40.
Frequency Range	26.965 to 27.405 MHz.
Frequency Control	Phase-Locked Loop (PLL) synthesizer.
Frequency Tolerance	0.005%
Operating Temp. Range	-30°C to +50°C.
Microphone	Plug-in type; dynamic.
Input Voltage	13.8 V DC nom. Positive or negative ground.
Current Drain	Transmit: AM full mod., 1.5 A. (maximum). Receive: (Squelched, 0.4 A; full audio output 1.2 A. (nominal). Channel Saver: Unit off 25 mA.
Size	8½"D × 7¼"W × 2¼"H. (216 mm×185 mm×56 mm)
Weight	4 lbs., 10 oz.
Antenna Connector	UHF, SO-239.
Semiconductors	41 transistors, 38 diodes, 6 integrated circuits, 21 LEDs.
Meter	Indicates relative power output and received signal strength.

TRANSMITTER

Power Output	4 watts.
Modulation	High-and low-level Class B amplitude.
Frequency	300 to 2500 Hz.
Output Impedance	50 ohms, unbalanced.

RECEIVER

Sensitivity	Less than 1 μ V for 10 dB (S+N)/N.
Selectivity	6 dB @ 7 KHz, 60 dB @ 10 KHz.
Image Rejection	80 dB, typical.
Adjacent Ch. Rejection	60 dB, typical.
IF Frequencies	Double conversion, 1st: 10.695 MHz. 2nd: 455 KHz.
Automatic Gain Control (AGC)	Less than 10 dB change in audio output for inputs from 10 to 50,000 microvolts.
Squelch	Adjustable; threshold less than 1 μ V.
Audio Output Power	4 watts.
Frequency Response	300-3000 Hz.
Distortion	Less than 7% @ 3 watts @ 1000 Hz.
Built-in Speaker	8 ohms, round.
External Speaker	8 ohms; disables internal speaker when connected.

PA SYSTEM

Power Output

4 watts into external speaker.

External Speaker for PA

8 ohms; a separate jack is provided.

(SPECIFICATIONS SUBJECT TO CHANGE WITHOUT NOTICE)

BLOCK DIAGRAM 29 PLUS

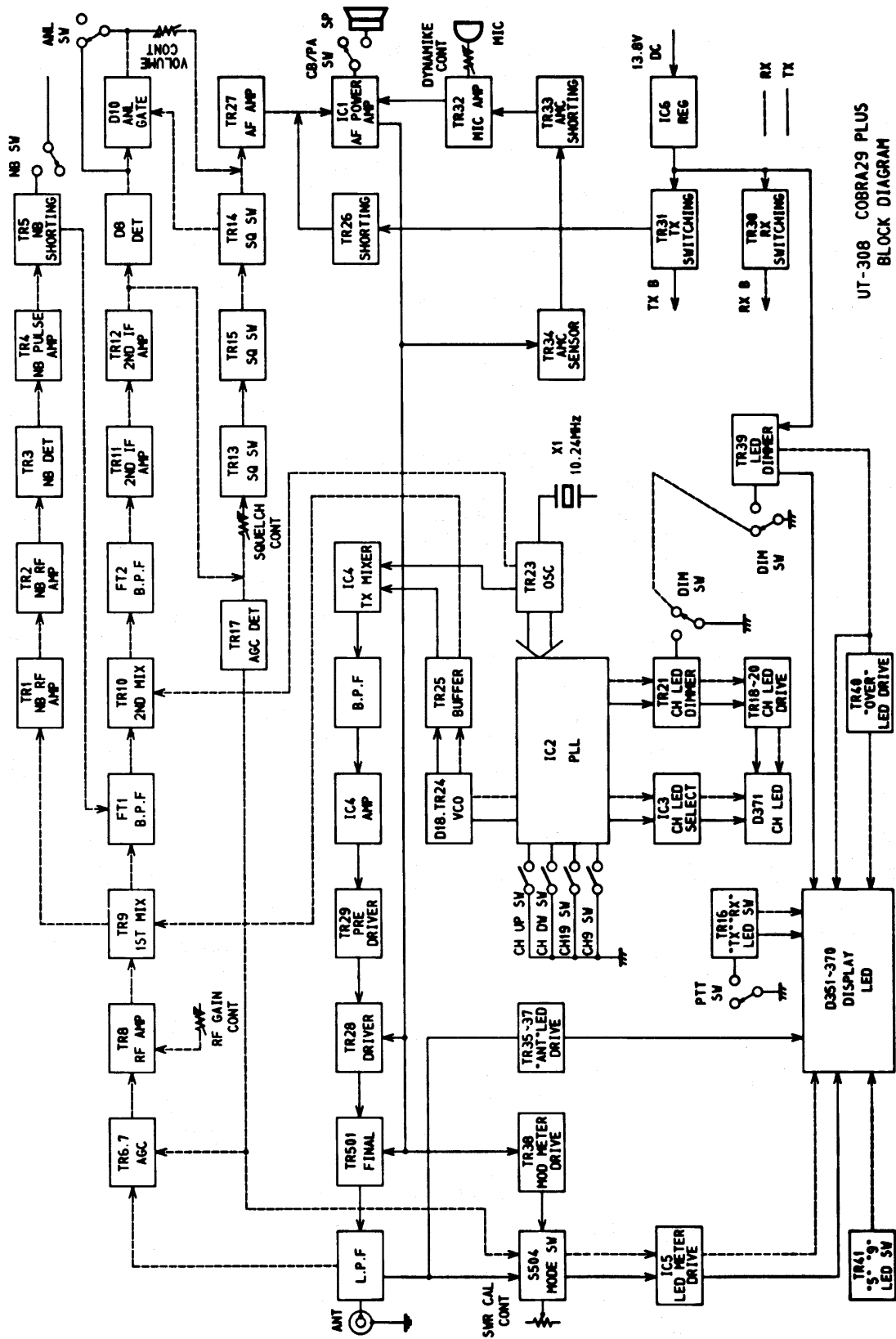

UT-308 COBRA29 PLUS
BLOCK DIAGRAM

CIRCUIT DESCRIPTIONS

1. PHASE LOCK LOOP

The PLL circuit shown below precisely controls the transmit frequency for each channel and generates a precise 1st local mixer frequency for the selected channel of the receiver. The 7 major parts are the Voltage Controlled Oscillator (VCO), 1/N Divider, Phase Detector, Low Pass Filter, Reference Oscillator (10.24 MHz), 1/2048 Divider and Channel ROM (Read Only Memory).

PLL CIRCUIT

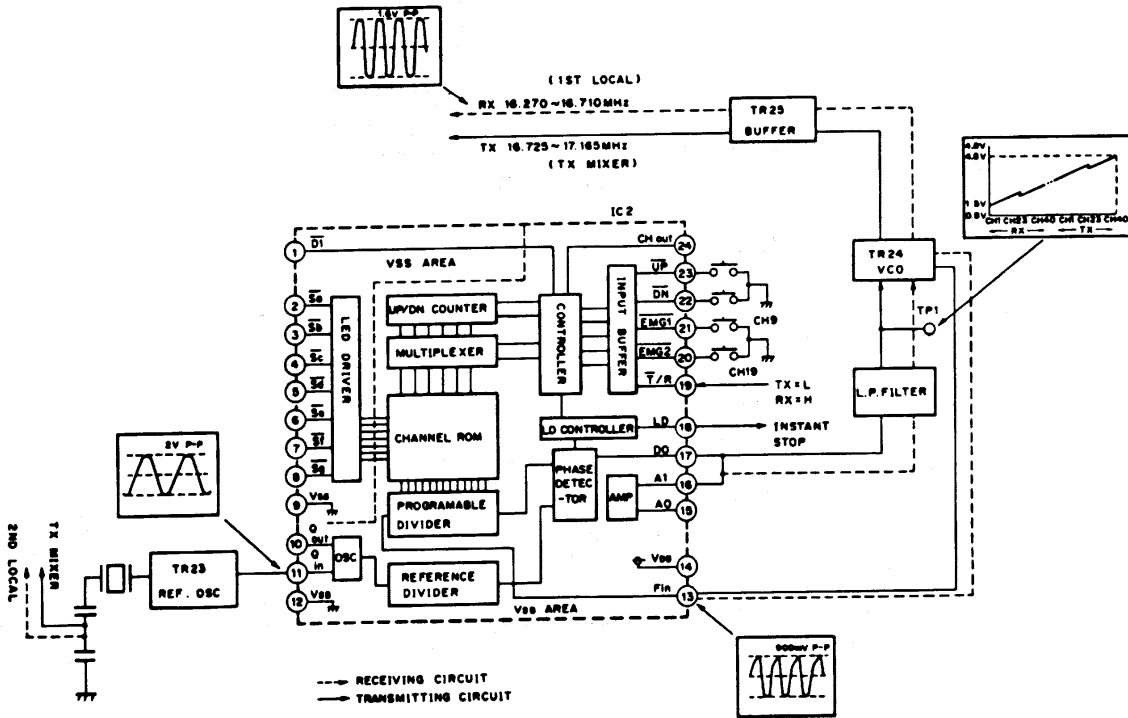

The VCO is an oscillator which controls oscillation frequency in accordance with input voltage change. The VCO output is mixed with a signal in the transmitter or receiver circuitry. A portion of the VCO frequency is fed to IC2 (1/N divider).

"N" for the 1/N divider is determined by the Channel Up/Down switch whose output is selected by a Channel ROM.

As shown in the frequency chart, N is different between transmit and receive modes, since only one crystal is used with this PLL circuitry.

The output from the 1/N divider is fed to the Phase Detector. The frequency from the reference OSC, 10.24 MHz, is divided to 5 kHz by the 1/2048 divider and applied to another input of the Phase Detector.

The Phase Detector compares the phase difference between these two input signals (both 5 kHz), generating an error voltage (DO), which acts on the VCO to bring the two frequencies exactly in-phase. When this condition occurs, the PLL circuit is locked.

A Low Pass Filter integrates the output of the Phase Detector which controls the VCO frequency. The program divider 1/N changes the frequency of the VCO (Fvco) in 10 kHz increments. For Example Channel No. 1 transmit divide Ratio "N" is programmed to 3345.

Therefore $F_{vco} = 5 \times 3345 = 16.725$ (MHz).

Fvco is determined the same way for all other channels as shown in table A.

Channel Selection Program

The Up/Down channel switches change the input voltage at either pin #22 or pin #23 of IC2 to select the desired channel. The divide ratio of the programmable frequency divider in IC2 is then determined through a code converter and the state of the transmit/receive mode switch (T/R) in IC2. The PTT switch determines the state of T/R in IC2 by changing the voltage at pin #19 from HIGH (receive) to LOW (transmit). The change between the two modes produces a 455 kHz change in VCO frequency.

Transmitter Output Frequency

The transmitter local oscillator of 10.24 MHz is produced by TR23 and crystal X1. The transmitter mixer IC4 mixes the local oscillator frequency 10.24 MHz, which is fed into pin #4 of IC4 and PLL Local Oscillator frequency (Fvco) produced by TR24/D18, which is fed into pin #1 of IC3. The sum of these two frequencies determines the transmitter carrier frequency (Ft). $F_t = F_{vco} + 10.24$ (MHz)

Receiver IF/Mixers

The 1st IF/Mixer TR9 receives the PLL local oscillator (Fvco) and receiver RF frequency (Fr) to produce 10.695 MHz.

$1ST\ IF = Fr - VCO = 10.695$ MHz.

The 2nd IF/Mixer (TR10) receives the 1st IF frequency (10.695 MHz) and local oscillator frequency (10.24 MHz) to produce the 2ND IF frequency, 455 kHz.

$2ND\ IF = 10.695 - 10.24 = 455$ (kHz).

2. CIRCUIT FOR PREVENTION OF UNAUTHORIZED FREQUENCY EMISSION

This Transceiver has a built-in circuit which prevents transmission of unauthorized frequencies during the time the PLL circuit is not locked.

When the PLL circuit is not locked or the program data input is not for channel 1–40, Pin 18 in IC2 produces a low level digital control signal. This signal is fed to Pin 7 of IC4 transmitter mixer through D31 diode. When this signal is at low level, IC4 is disabled; and no RF signals are fed to the next stages.

IC2 is designed internally to operate only with valid data required for channel 1–40, thereby eliminating the RF signal output, and preventing any unauthorized frequencies.

TABLE A: FREQUENCY CHART OF Fvco AND DIVIDE RATIO N

Antenna Frequency (MHz)	Channel Number	For Transmit (Pin 19 of IC2=L)		For Receive (Pin 19 of IC2=H)	
		Divide Ratio (N)	VCO Frequency (MHz)	Divide Ratio (N)	VCO Frequency (MHz)
26.965	1	3345	16.725	3254	16.270
26.975	2	3347	16.735	3256	16.280
26.985	3	3349	16.745	3258	16.290
27.005	4	3353	16.765	3262	16.310
27.015	5	3355	16.775	3264	16.320
27.025	6	3357	16.785	3266	16.330
27.035	7	3359	16.795	3268	16.340
27.055	8	3363	16.815	3272	16.360
27.065	9	3365	16.825	3274	16.370
27.075	10	3367	16.835	3276	16.380
27.085	11	3369	16.845	3278	16.390
27.105	12	3373	16.865	3282	16.410
27.115	13	3375	16.875	3284	16.420
27.125	14	3377	16.885	3286	16.430
27.135	15	3379	16.895	3288	16.440
27.155	16	3383	16.915	3292	16.460
27.165	17	3385	16.925	3294	16.470
27.175	18	3387	16.935	3296	16.480
27.185	19	3389	16.945	3298	16.490
27.205	20	3393	16.965	3302	16.510
27.215	21	3395	16.975	3304	16.520
27.225	22	3397	16.985	3306	16.530
27.255	23	3403	17.015	3312	16.560
27.235	24	3399	16.995	3308	16.540
27.245	25	3401	17.005	3310	16.550
27.265	26	3405	17.025	3314	16.570
27.275	27	3407	17.035	3316	16.580
27.285	28	3409	17.045	3318	16.590
27.295	29	3411	17.055	3320	16.600
27.305	30	3413	17.065	3322	16.610
27.315	31	3415	17.075	3324	16.620
27.325	32	3417	17.085	3326	16.630
27.335	33	3419	17.095	3328	16.640
27.345	34	3421	17.105	3330	16.650
27.355	35	3423	17.115	3332	16.660
27.365	36	3425	17.125	3334	16.670
27.575	37	3427	17.135	3336	16.680
27.385	38	3429	17.145	3338	16.690
27.395	39	3431	17.155	3340	16.700
27.405	40	3433	17.165	3342	16.710

3. RX OPERATIONS (Refer to block and schematic diagrams)

In the receive mode, switching transistor TR30 is turned ON to supply B+ voltage to the receiver section. TR33 is turned ON to mute the mic input. The transmit B+ switching transistor TR31 is OFF disabling the transmitter mixer IC4 and TR26 RX Audio mute transistor. The TX predriver TR29 is turned OFF by applying a B+ voltage to its emitter. The 2nd IF Amp TR12 modulated signal output is demodulated by detector diode D8. The recovered audio is amplified by TR27, fed to the power amp IC1 and then to the speaker. The output of TR12 also drives or controls the output levels of the AGC detector TR17 and the squelch circuit. When a Low RF signal is received by the antenna, the output of the AGC line is low and TR6 and TR7 are OFF allowing maximum RF signal to reach TR8 and maximum IF gain of TR10. When the RF signal strength increases, the AGC line voltage increases and causes current to flow through TR5 and TR6. This attenuates the RF input signal level to TR8, and decreases the gain of TR10, thereby preventing overload distortion and cross modulation deterioration. TR12 drives diode D9, producing a negative voltage at C31 to offset the squelch preset level and turn OFF TR13. Current flows through TR15 causing TR14 to turn "OFF" and unsquelch the output. Automatic Noise Limiting (ANL) is performed by diode D10.

4. TX OPERATION (Refer to block and schematic diagrams)

In transmit mode, switching transistor TR31 is turned ON to supply Bias voltages to TX mixer IC4 and to turn "ON" TR26 to mute receive output. TR30 is turned "OFF" allowing TR29 and TR32 (mic amp) to turn "ON". Mic input signal is amplified by TR32 and fed to IC1 to drive the modulation Xformer T1 secondary which causes the TX stages B+ voltage to vary with mic signal amplitude. Automatic modulation control (AMC) is accomplished by level shift diode D20, TR33 and TR34. When mic input signal increases above a critical level, D20 conducts current causing TR34 to turn on TR33 which attenuates the mic input level, controlling the modulation level.

5. PA OPERATION

In PA standby mode the receiver is "ON" and incoming signals can be monitored on the PA speaker. When the PTT switch is ON, the signal flows through the Dynamike control to TR32 and IC1 to PA speaker. The transmitter section is OFF due to nonconducting TR31.

6. CHANNEL 9 CIRCUIT

When the CH 9 switch is ON, Pin 21 of IC2 is set low to activate channel 9 only.

ALIGNMENT PROCEDURE

1. PLL SECTION ALIGNMENT

1.1 Test Equipment Required

DC Power Supply (13.8 V)
 DC Voltmeter
 Oscilloscope
 Dummy Load (50 ohm) & Attenuator

1.2 Alignment Procedures

STEP	PRESET TO	ADJUSTMENT	REMARKS
1	CH : 40 Mode : TX	L8	Connect DC Voltmeter to TP1. Adjust for 4.5 V. After alignment, lock the core of L8 with paraffin.
2	CH : 19 Mode : RX	L9	Connect Oscilloscope probe to TP2. Adjust for maximum reading on Oscilloscope.

1.3 Test Equipment Connection

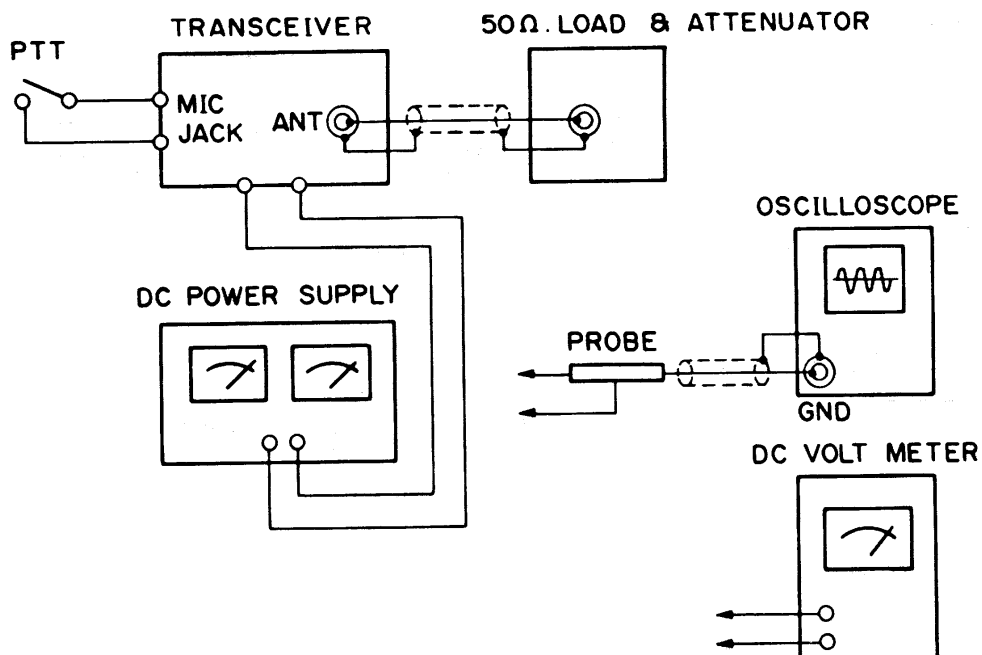

2. TRANSMITTER SECTION ALIGNMENT

2.1 Test Equipment Required

DC Power Supply (13.8 V)
 AF Generator (Audio Frequency Oscillator)
 Oscilloscope
 RF Power Meter
 Dummy Load (50 ohm, 200 ohm)

2.2 Preset to

- a) CH 9 : OFF
- b) PA : OFF
- c) DYNAMIKE : Maximum (fully clockwise)
- d) S-RF/MOD/CAL/SWR : S-RF

2.3 Alignment Procedures

STEP	PRESET TO	ADJUSTMENT	REMARKS
1	CH : 19 No mod.	L16, L17 and L18	Connect Oscilloscope probe to TP3. Adjust coils for maximum reading.
2	CH : 19 No mod.	L15 and L12	Connect RF Power Meter to Antenna Jack (J501). Adjust coils for maximum reading.
3	CH : 19 No mod.	L12	Adjust for 4.0W on RF Power Meter.
4	CH : 19 No mod.	VR3	1. Reduce DC volt to obtain 3.1W on RF Power Meter. 2. Adjust VR3 to the point at which 6th digit LED just lights.
5	CH : 19 1 kHz 80% mod. MODE SW : MOD.	VR5	Same as STEP 4.
6	CH : 19 No mod.	VR4	Connect 200 ohm Dummy Load to Antenna Jack (J501). Adjust to the point at which ANT LED just lights.

2.4 Test Equipment Connection

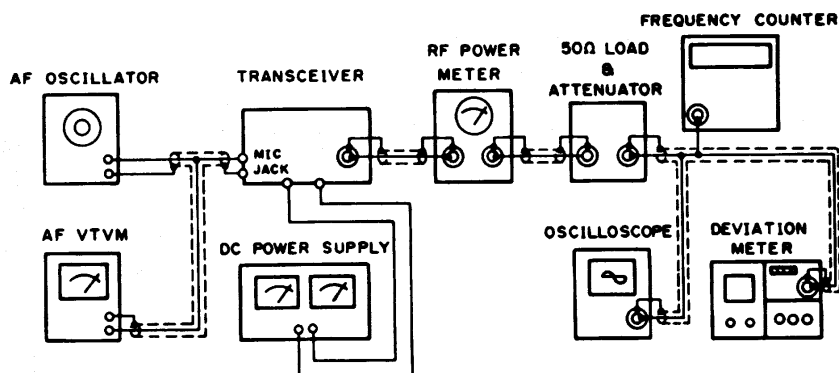

3. RECEIVER SECTION ALIGNMENT

3.1 Test Equipment Required

DC Power Supply (13.8 V)
 S.S.G. (Standard Signal Generator, with Attenuator)
 AF Voltmeter
 Oscilloscope
 Dummy Load (8 ohm)

3.2 Preset to

- a) CH 9 : OFF
- b) PA : OFF
- c) ANL : OFF
- d) NB : OFF
- e) SQUELCH : Minimum (fully counterclockwise)
- f) RF GAIN : Maximum (fully clockwise)
- g) S-RF/MOD/CAL/SWR : S-RF
- h) S.S.G. : 27.185 MHz (19 CH)
 modulation 1 kHz 30%

3.2 Alignment Procedures

STEP	PRESET TO	ADJUSTMENT	REMARKS
1	CH : 19 VOLUME : Max. S.S.G. : Mod.on	L2, L3, L4, L5, L6, L7	Connect S.S.G. to Antenna Jack(J501). Connect AF Voltmeter and Oscilloscope to EXT SP Jack (J3). Adjust coils for maximum reading. During this alignment, decrease RF signal so that AF voltage will not exceed 2V.
2	CH : 18 NB : ON S.S.G. : 100 μ V No mod.	L1	Connect probe of Oscilloscope to TP4. Adjust for maximum reading.
3	CH : 19 S.S.G. : 100 μ V No mod.	VR1	Adjust until S9 of Transceivers LED Meter just lights.
4	CH : 19 VOLUME : Max. SQUELCH : Max. S.S.G. : 1 mV w/ 30% mod.	VR2	Connect AF Voltmeter and Oscilloscope to EXT SP Jack (J3). Adjust so that the AF signal will just appear on Oscilloscope.

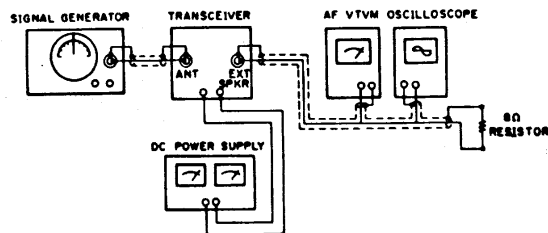

ALIGNMENT POINTS

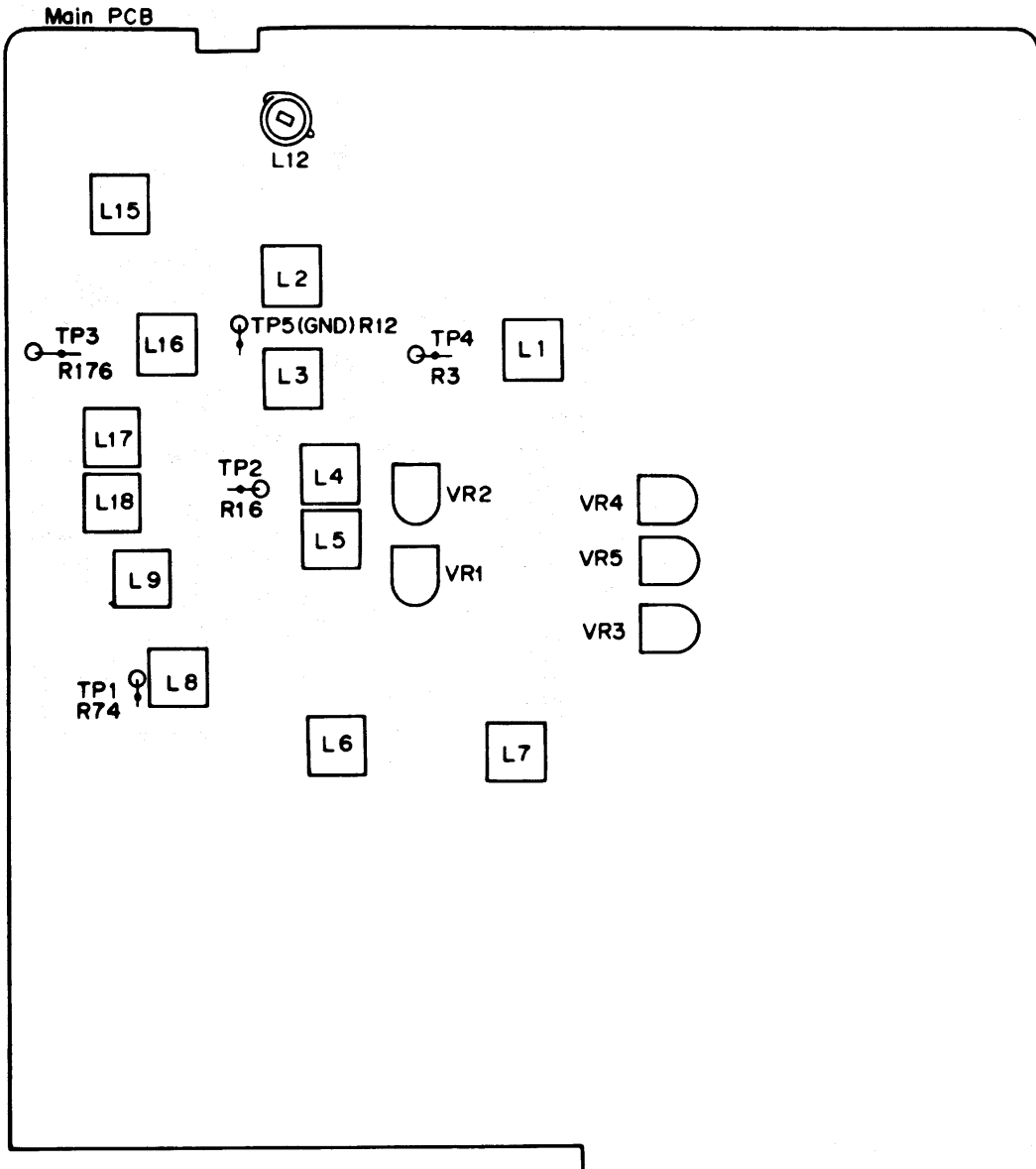

TROUBLESHOOTING HINTS

UNIT WILL NOT TURN ON

1. Blown fuse.
2. Defective Power Switch.
3. Defect in Power Supply Circuit.

NO SOUND RECEIVED

1. Defective external speaker jack.
2. Bad contact in the microphone jack.
3. Bad PTT switch in the microphone.
4. Unlocked PLL circuit or improper alignment.
5. Defective PA switch.

NO TRANSMISSION

1. Defective microphone jack.
2. Defective PTT switch on microphone.
3. Unlocked PLL circuit or improper alignment.
4. Defective PA switch.

NO TX MODULATION

1. Defective microphone and/or circuit.
2. Defect in modulation circuit.

FOR MORE HINTS, SEE BELOW

NO TRANSMISSION

- Connect current meter in series with power cable. Check current reading for transmit mode:
- A. If current reads more than 1 ampere (but less than 2 A.), the final output transistor is OK. Check for bad contacts or short circuits between PC Board and Antenna Connector. A current reading of less than 0.5 A indicates no drive to Final Transistor. Check drive or early RF stages.
 - B. Defective PLL?
Check voltage at Pin 18 of IC2. If less than 5 V, PLL is unlocked. If more than 5 V, PLL is OK.
 - C. Short Circuit in Transmitter Circuit?
Voltage on Pin 1 of IC6 should be less than 7 V in TX mode, and should increase to more than 7 V in RX mode.
 - D. If voltage reading is more than 7 V on TR31 collector, it is OK. If voltage of more than 2 V is measured at the D21 anode, check microphone circuit.
 - E. If RF voltage (27 MHz) is more than 1.5 V P-P at TP3, previous stages are OK.
 - F. No voltage readings at TR28 and TR501 collector: check D19 or T-1.
 - G. No Channel LED light: If one particular segment does not light, the LED is defective. If LED does not light in any channel position, check IC3.

CHANNEL UP/DOWN SWITCH INOPERATIVE

If channel does not go up or down when Channel Up/Down Switch is pressed, check IC2 and connection of Channel Up/Down Switch.

CHANNEL LED DOES NOT LIGHT

If one particular channel does not light, check molex, LED, or Channel Up/Down Switch. If no channel lights, check IC3 or molex.

NO TX MODULATION

If receiver operates correctly, but there is no TX modulation, the problem should be in TR32, TR33, TR34, or a short circuit in the microphone circuit. Audio power IC1 is used both for TX and RX modes.

NO RECEPTION

Before troubleshooting, check Squelch Control full CCW, RF Gain Control full CW, and microphone connected.

- A) Connect Signal Generator to antenna. Check that Signal Strength Meter (S meter) LEDs light.

S meter LEDs light.

Antenna is OK through IF stage; check circuit through ANL, Squelch and Audio amplifier. During the illumination of S meter, negative voltage should be present at anode of D8 diode if Detector circuit is normal.

S meter LEDs do not light.

To check PLL:

1. 16 MHz frequency should be present at TP2 (0.9 V P-P or more).
2. The frequencies shown in the frequency chart should be correct when the Channel Up-Down Switch is changed from CH 1 through CH 40.
3. 10.24 MHz frequency should be present at C51 (0.4 V P-P or more). If PLL is OK, check circuit through TR8, TR9, TR10, TR11 and TR12.

- B) Check Audio stage for operation: Connect Speaker to PA Speaker Jack, and set PA-CB switch to PA. If there is an audible click when the PTT switch is pressed, Audio stage is OK. If there is no audible click, IC1 Audio Amplifier is defective, or T-1 transformer is bad. (Transformer DC resistance should be approximately 0.5 ohm for both primary and secondary windings.)

- C) Defective Audio Power IC?
If voltage at Pin 6 is 7 V (VCC/2), IC1 is OK.

- D) Squelch constantly "on".
If voltage at the base of TR14 is 0 V, TR27 is defective. If reading is less than 0.7 V, check TR15 circuit and/or Squelch control ground connection for cold solder.

PLL CIRCUIT TROUBLESHOOTING HINTS

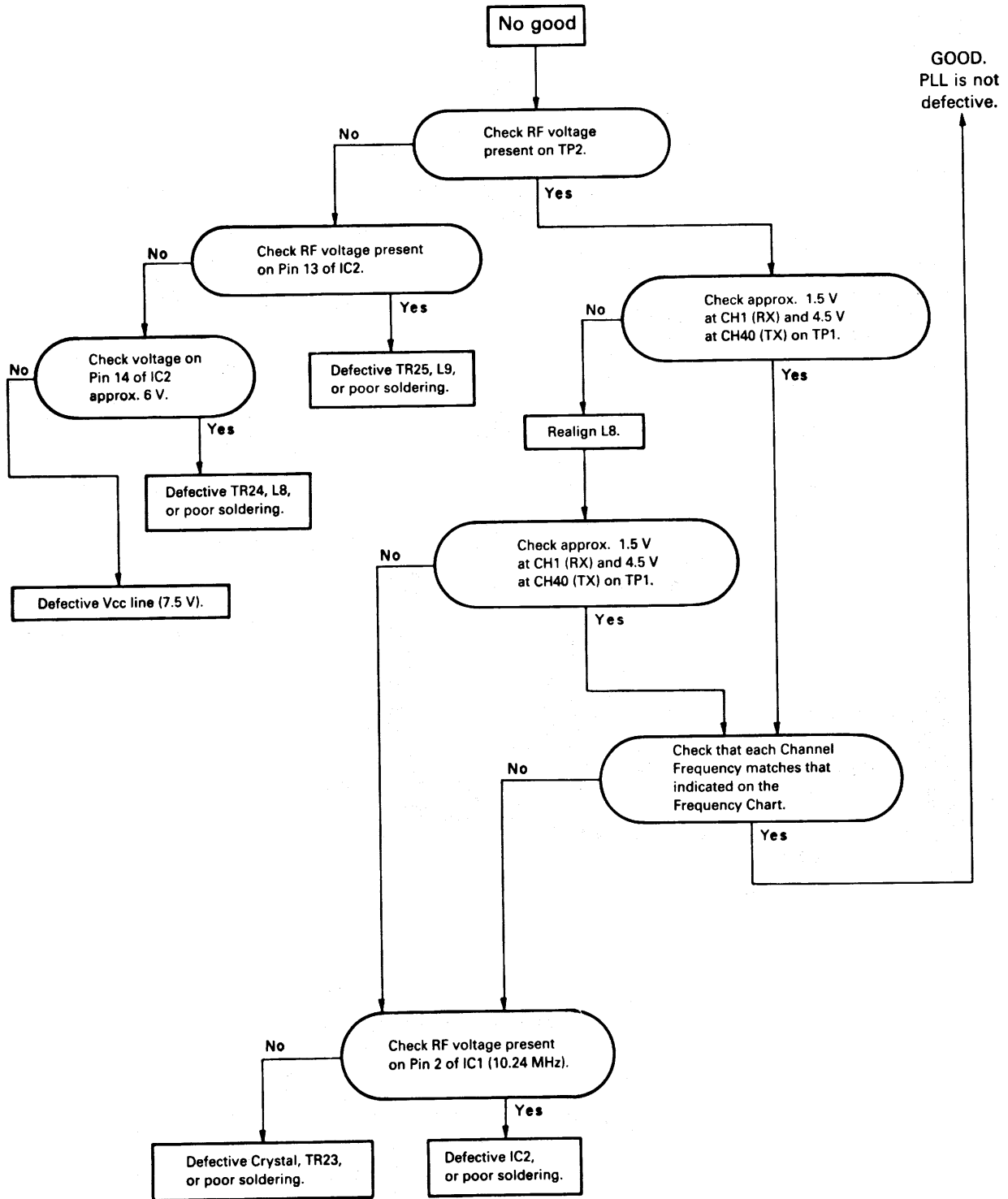

ADDITIONAL PARTS ON THE BOTTOM

MAIN P.C. BOARD

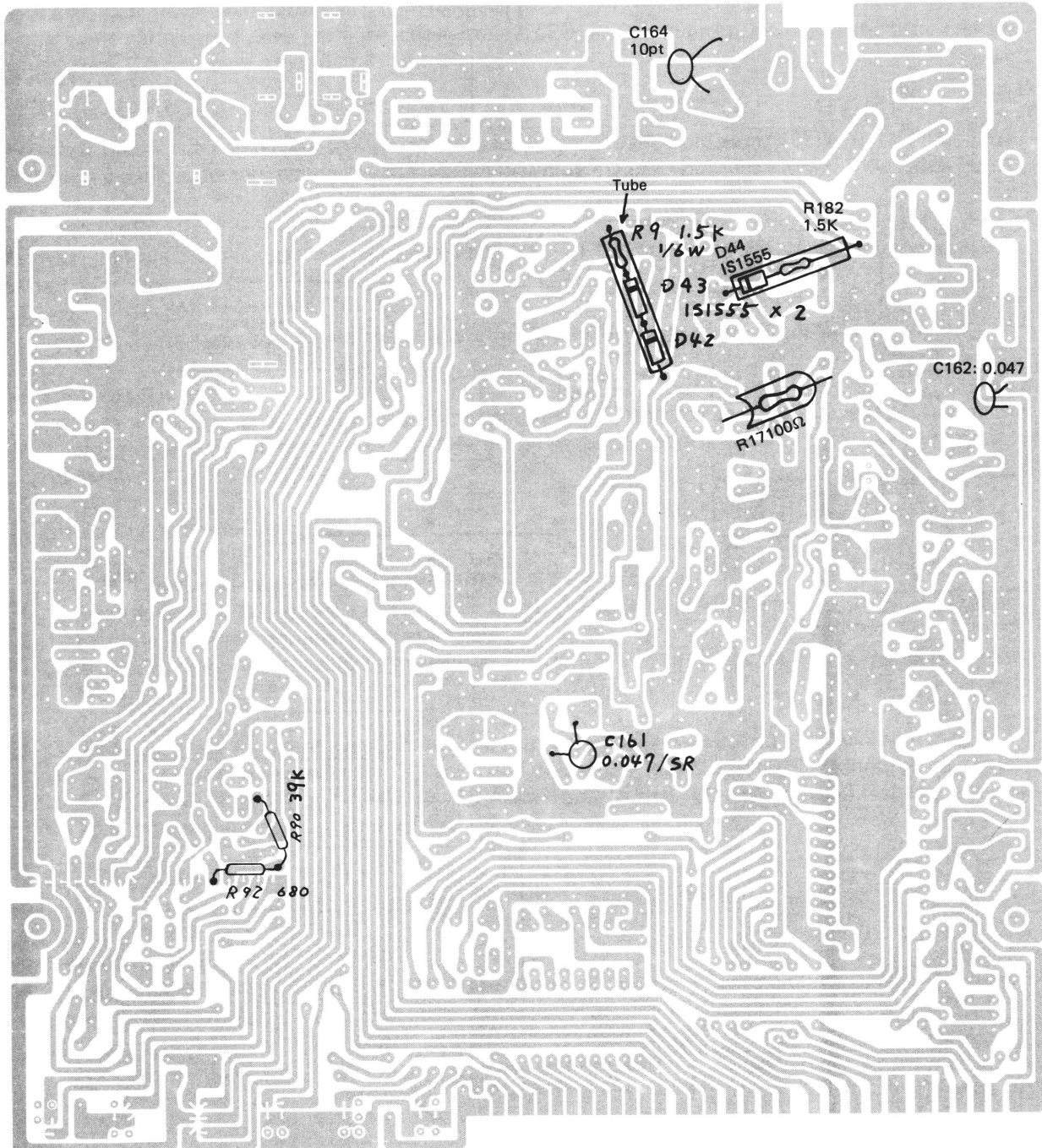

MAIN P.C. BOARD (TOP VIEW)

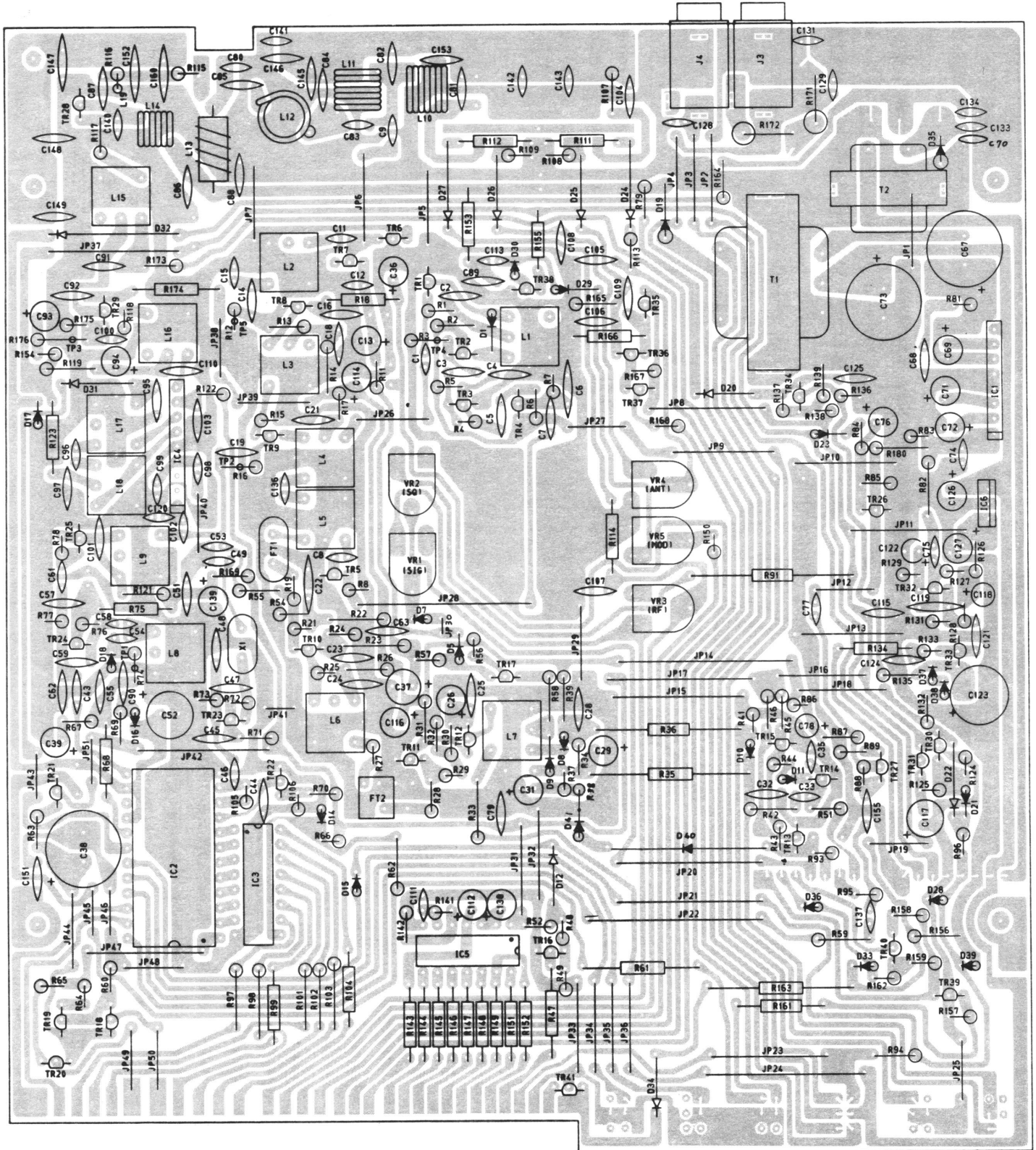

MAIN P.C. BOARD (BOTTOM VIEW)

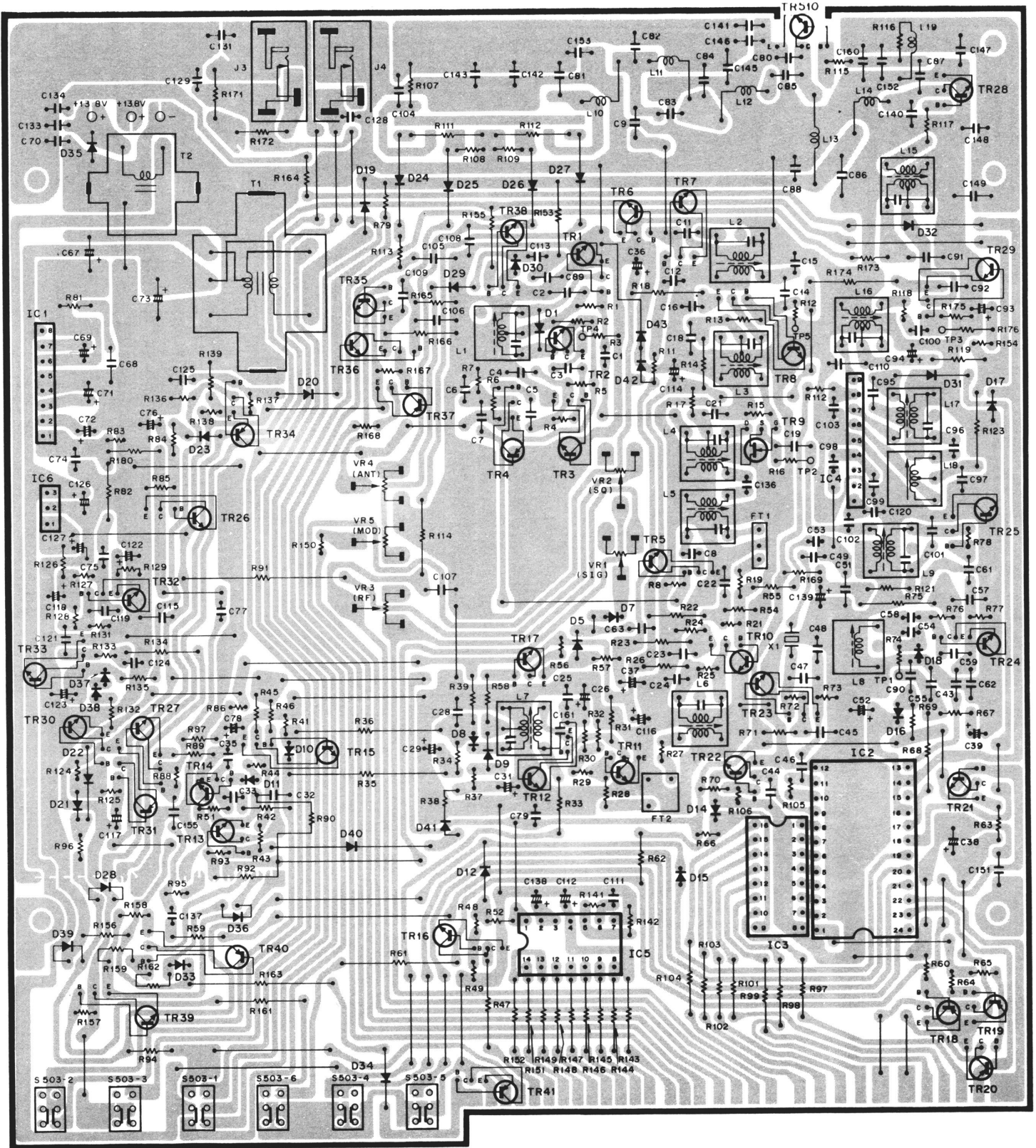

FRONT P.C. BOARD (TOP & BOTTOM)

(TOP VIEW)

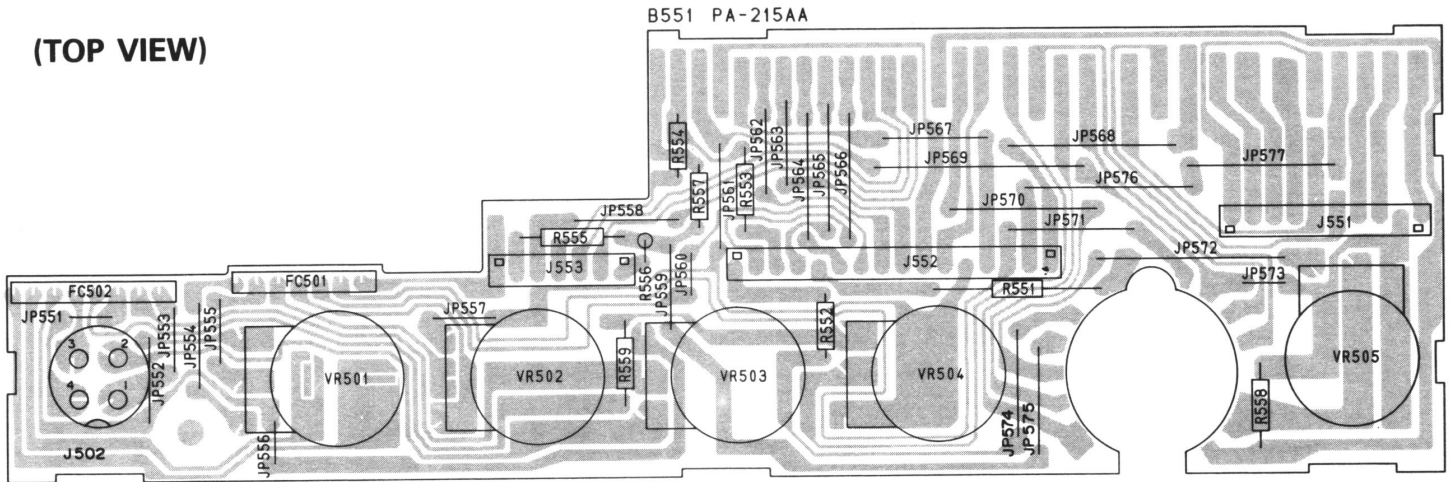

LED P.C. BOARD (TOP & BOTTOM)

(TOP VIEW)

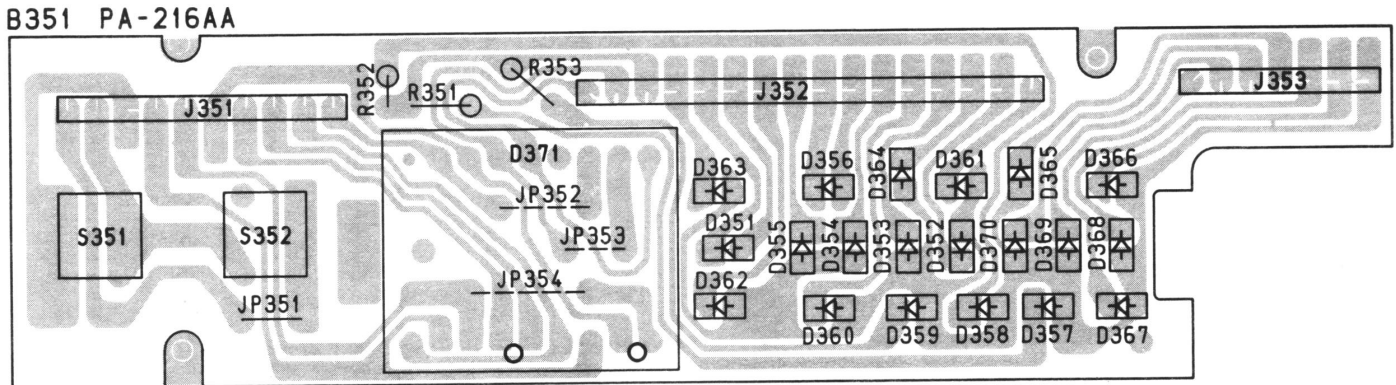

(BOTTOM VIEW)

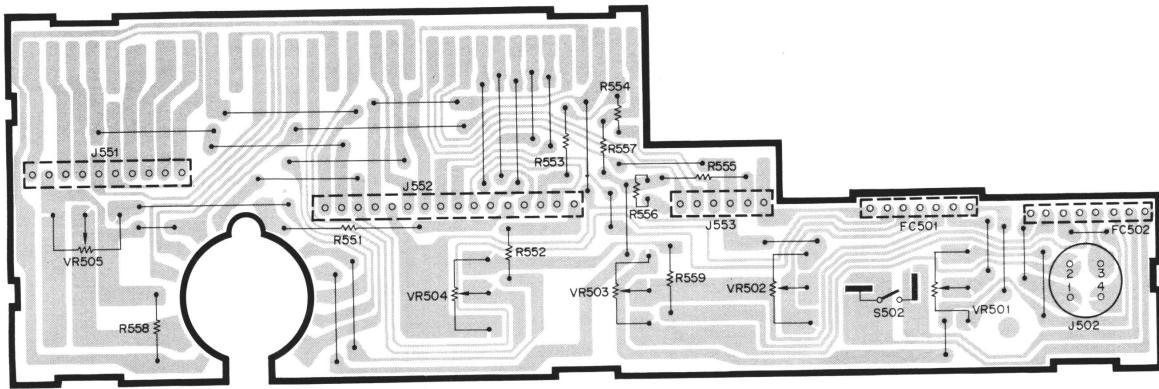

(BOTTOM VIEW)

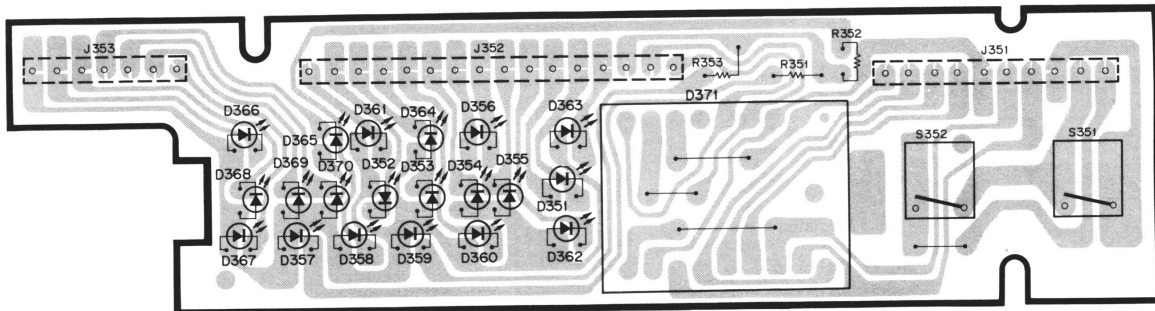

WIRING DIAGRAM

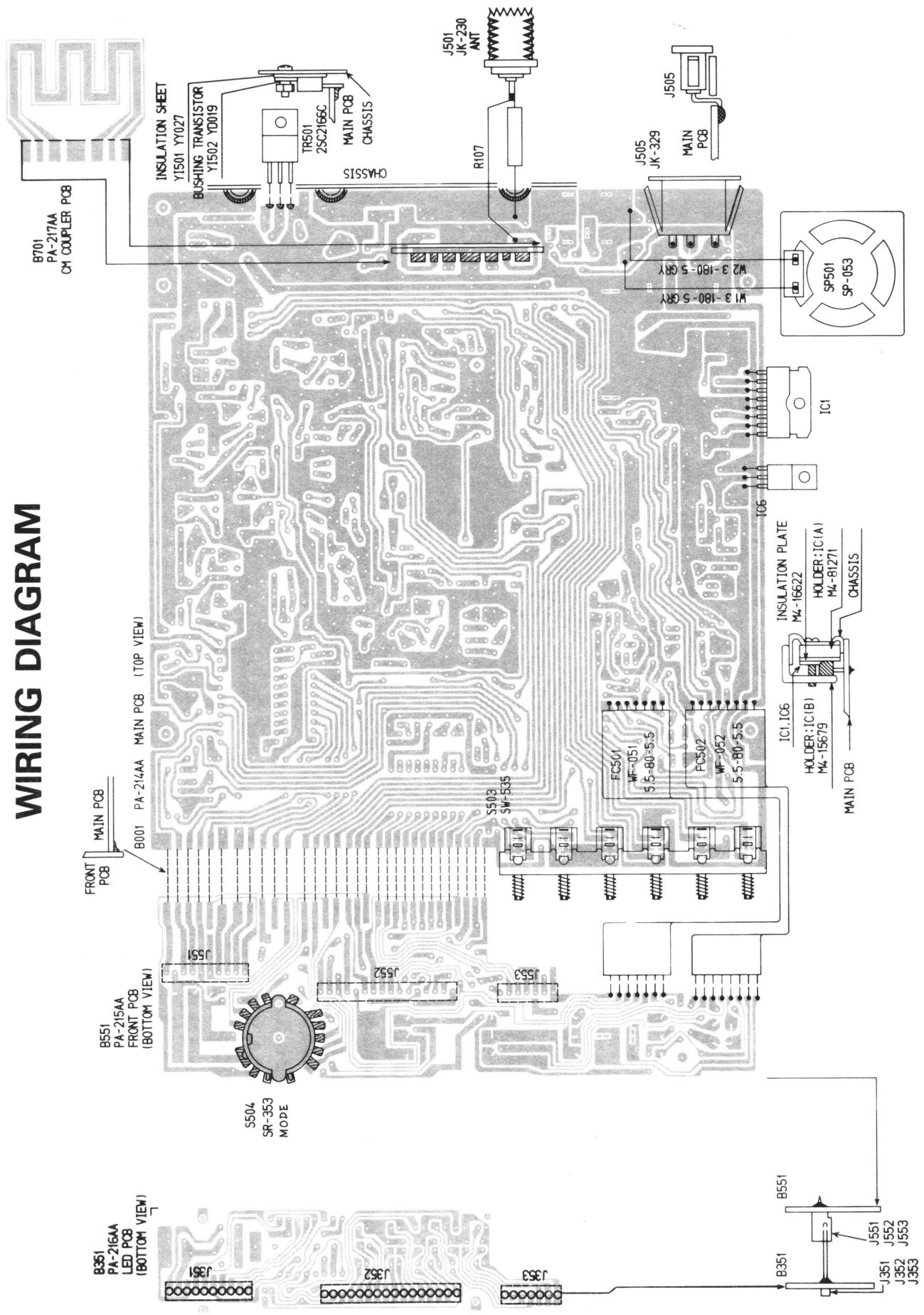

COPPER PATTERN LAYOUT

MAIN P.C. BOARD

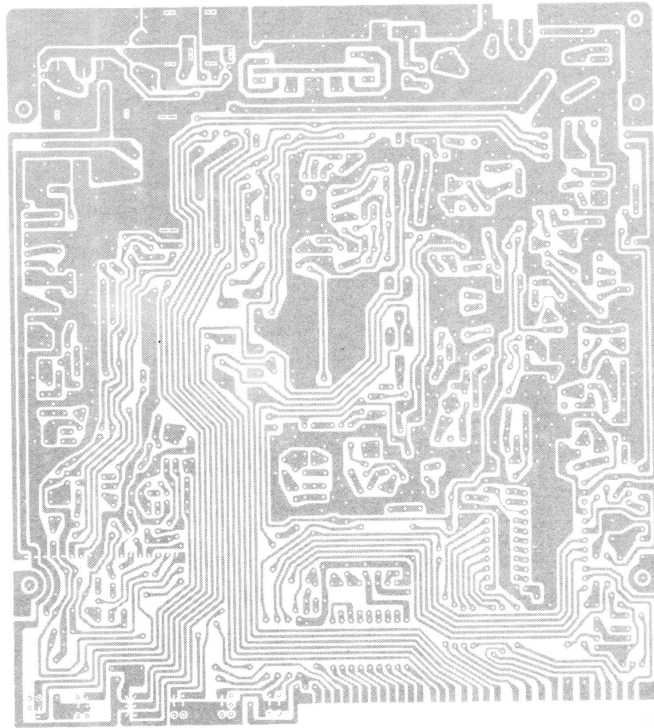

FRONT P.C. BOARD

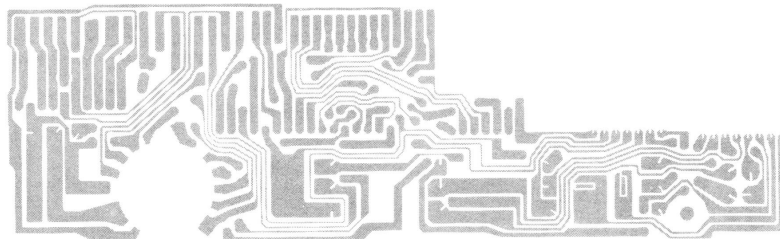

LED P.C. BOARD

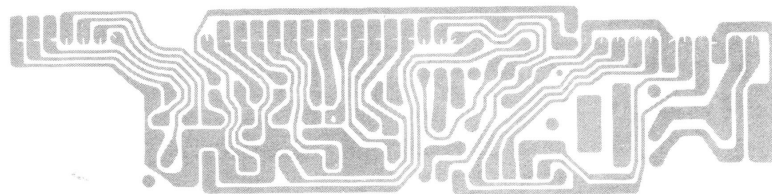

ELECTRICAL PARTS LIST

REF. NO.	DESCRIPTION	DYNASCAN PART NO.
CAPACITORS		
<p>NOTE: The first code indicates tolerance of capacitance: C=±0.25 pF, D=±0.5 pF, F=±1 pF, G=±2%, J=±5%, K=±10%, M=±20%, Z=+70% -20% The second code indicates variation of capacitance with temperature: YA=±5%, YB=±10%, YD=+20% -30%, YE=+20 -50%, YF=+30 -70% (-25~+85°C) ZF=+30 -80% (-10~+70°C), CH=0±60 ppm/°C, RH=-220 ppm/°C±60 ppm/°C, CJ=0±120 ppm/°C, RJ=-220 ppm/°C±120 ppm/°C, TH=-470 ppm/°C±60 ppm/°C, UJ=-750 ppm/°C±120 ppm/°C, SL=+350 ppm/°C~-1000 ppm/°C</p>		
C-1 C-2 C-3 C-4 C-5 C-6 C-7 C-8 C-9 C-10 C-11 C-12 C-13 C-14 C-15 C-16 C-17 C-18 C-19 C-20 C-21 C-22 C-23 C-24 C-25 C-26 C-27 C-28 C-29 C-30 C-31 C-32 C-33 C-34 C-35 C-36 C-37 C-38 C-39 C-40 C-41 C-42	Capacitor, Ceramic 22 pF 50V K SL Capacitor, Ceramic 0.01 μF 50V Z YF Capacitor, Ceramic 0.01 μF 50V Z YF Capacitor, Ceramic 220 pF 50V K SL Capacitor, Ceramic 220 pF 50V K SL Capacitor, Ceramic 680 pF 50V K SL Capacitor, Ceramic 0.01 μF 50V Z YF Capacitor, Semi-conductor (SR) 0.01 μF 25V K Capacitor, Ceramic 22 pF 50V K UJ -Not used- Capacitor, Ceramic 0.001 μF 50V Z YF Capacitor, Ceramic 0.0047 μF 50V Z YF Capacitor, Electrolytic 2.2 μF 50V Capacitor, Ceramic 220 pF 50V K SL Capacitor, Ceramic 47 pF 50V K SL Capacitor, Ceramic 0.01 μF 50V Z YF -Not used- Capacitor, Ceramic 0.01 μF 50V Z YF Capacitor, Ceramic 0.01 μF 50V Z YF -Not used- Capacitor, Ceramic 0.01 μF 50V Z YF Capacitor, Ceramic 0.047 μF 25V K Z ZF Capacitor, Semi-conductor (SR) 0.047 μF 25V K Capacitor, Semi-conductor (SR) 0.047 μF 25V K Capacitor, Semi-conductor (SR) 0.047 μF 25V K Capacitor, Electrolytic 10 μF 25V M C-155 -Not used- Capacitor, Ceramic 220 pF 50V K SL Capacitor, Electrolytic 1 μF 50v -Not used- Capacitor, Electrolytic 10 μF 16V Capacitor, Semi-conductor (SR) 0.0022 μF 25V K Capacitor, Ceramic 0.001 μF 50V K YB(B) -Not used- Capacitor, Semi-conductor (SR) 0.001 μF 25V K Capacitor, Electrolytic 10 μF 16V Capacitor, Electrolytic 47 μF 25V Capacitor, Electrolytic 1000 μF 10V Capacitor, Electrolytic 1 μF 50V M C-094 -Not used- -Not used- -Not used-	

REF. NO.	DESCRIPTION	DYNASCAN PART NO.
C-43	Capacitor, Ceramic 22 pF 50V K SL	
C-44	Capacitor, Ceramic 0.047 μ F 25V Z ZF	
C-45	Capacitor, Ceramic 0.01 μ F 50V Z YF	
C-46	Capacitor, Ceramic 22 pF 50V K SL	
C-47	Capacitor, Ceramic 390 pF 50V J SL	
C-48	Capacitor, Ceramic 150 pF 50V K SL	
C-49	Capacitor, Ceramic 47 pF 50V J CH	
C-50	- Not used -	
C-51	Capacitor, Ceramic 470 pF 50V K SL	
C-52	Capacitor, Electrolytic 330 μ F 6.3V M C-095	
C-53	Capacitor, Ceramic 0.001 μ F 50V Z YF	
C-54	Capacitor, Ceramic 68 pF 50V K UJ	
C-55	Capacitor, Semi-conductor (SR) 0.1 μ F 25V K	
C-56	- Not used -	
C-57	Capacitor, Ceramic 0.0022 μ F 50V M YD	
C-58	Capacitor, Ceramic 33 pF 50V K RH	
C-59	Capacitor, Ceramic 220 pF 50V K UJ	
C-60	- Not used -	
C-61	Capacitor, Ceramic 15 pF 50V K SL	
C-62	Capacitor, Ceramic 150 pF 50V K UJ	
C-63	Capacitor, Ceramic 0.01 μ F 50V Z YF	
C-64	- Not used -	
C-65	- Not used -	
C-66	- Not used -	
C-67	Capacitor, Electrolytic 470 μ F 25V	
C-68	Capacitor, Semi-conductor (SR) 0.1 μ F 25V K	
C-69	Capacitor, Electrolytic 47 μ F 10V	
C-70	Capacitor, Ceramic 0.01 μ F 50V Z YF	
C-71	Capacitor, Electrolytic 22 μ F 16V	
C-72	Capacitor, Electrolytic 10 μ F 16V	
C-73	Capacitor, Electrolytic 1000 μ F 25V M C-095	
C-74	Capacitor, Ceramic 0.001 μ F 50V M YD	
C-75	Capacitor, Semi-conductor (SR) 0.0047 μ F 25V K	
C-76	Capacitor, Electrolytic 47 μ F 10V	
C-77	Capacitor, Semi-conductor (SR) 0.0033 μ F 25V K	
C-78	Capacitor, Electrolytic 47 μ F 10V	
C-79	Capacitor, Ceramic 0.047 μ F 25V Z ZF	
C-80	Capacitor, Ceramic 100 pF 50V K SL	
C-81	Capacitor, Ceramic 150 pF 50V K SL	
C-82	Capacitor, Ceramic 270 pF 50V K UJ	
C-83	Capacitor, Ceramic 33 pF 50V K CH	
C-84	Capacitor, Ceramic 220 pF 50V K UJ	
C-85	Capacitor, Ceramic 0.001 μ F 50V K YB(B)	
C-86	Capacitor, Ceramic 0.047 μ F 50V Z YF	
C-87	Capacitor, Ceramic 270 pF 50V K UJ	
C-88	Capacitor, Ceramic 0.047 μ F 50V Z YF	
C-89	Capacitor, Ceramic 0.01 μ F 50V Z YF	
C-90	Capacitor, Ceramic 0.01 μ F 50V Z YF	
C-91	Capacitor, Ceramic 0.01 μ F 50V Z YF	
C-92	Capacitor, Ceramic 0.0047 μ F 50V M YD	
C-93	Capacitor, Electrolytic 47 μ F 10V	
C-94	Capacitor, Electrolytic 47 μ F 10V	
C-95	Capacitor, Ceramic 0.01 μ F 50V Z YF	
C-96	Capacitor, Ceramic 0.5 pF 50V C SL	
C-97	Capacitor, Ceramic 0.01 μ F 50V Z YF	
C-98	Capacitor, Ceramic 5 pF 50V C SL	
C-99	Capacitor, Ceramic 5 pF 50V C SL	

REF. NO.	DESCRIPTION	DYNASCAN PART NO.
C-100	Capacitor, Ceramic 0.001 μ F 50V Z YF	
C-101	Capacitor, Semi-conductor (SR) 0.01 μ F 25V K	
C-102	Capacitor, Ceramic 100 pF 50V K SL	
C-103	Capacitor, Ceramic 0.01 μ F 50V Z YF	
C-104	- Not used -	
C-105	Capacitor, Ceramic 0.01 μ F 50V Z YF	
C-106	Capacitor, Ceramic 0.047 μ F 25V Z ZF	
C-107	Capacitor, Ceramic 0.01 μ F 50V Z YF	
C-108	Capacitor, Ceramic 0.01 μ F 50V Z YF	
C-109	Capacitor, Ceramic 0.047 μ F 25V Z ZF	
C-110	Capacitor, Ceramic 0.01 μ F 50V Z YF	
C-111	Capacitor, Ceramic 0.001 μ F 50V Z YF	
C-112	Capacitor, Electrolytic 2.2 μ F 50V	
C-113	Capacitor, Mylar 0.1 μ F 50V K	
C-114	Capacitor, Electrolytic 47 μ F 10V	
C-115	Capacitor, Semi-conductor (SR) 0.047 μ F 25V K	
C-116	Capacitor, Electrolytic 47 μ F 25V	
C-117	Capacitor, Electrolytic 100 μ F 10V	
C-118	Capacitor, Electrolytic 100 μ F 10V	
C-119	Capacitor, Ceramic 560 pF 50V K SL	
C-120	Capacitor, Ceramic 56 pF 50V K SL	
C-121	Capacitor, Semi-conductor (SR) 0.047 μ F 25V K	
C-122	Capacitor, Electrolytic 47 μ F 10V	
C-123	Capacitor, Electrolytic 220 μ F 16V M C-155	
C-124	Capacitor, Semi-conductor (SR) 0.01 μ F 25V K	
C-125	Capacitor, Ceramic 0.047 μ F 25V K Z ZF	
C-126	Capacitor, Electrolytic 10 μ F 16V	
C-127	Capacitor, Electrolytic 10 μ F 16V	
C-128	Capacitor, Ceramic 0.001 μ F 50V Z YF	
C-129	Capacitor, Ceramic 0.001 μ F 50V Z YF	
C-130	- Not used -	
C-131	Capacitor, Ceramic 0.001 μ F 50V Z YF	
C-132	- Not used -	
C-133	Capacitor, Ceramic 0.001 μ F 50V Z YF	
C-134	Capacitor, Ceramic 0.001 μ F 50V Z YF	
C-135	- Not used -	
C-136	Capacitor, Ceramic 100 pF 50V K SL	
C-137	Capacitor, Ceramic 0.001 μ F 50V Z YF	
C-138	Capacitor, Electrolytic 1 μ F 50V	
C-139	Capacitor, Electrolytic 100 μ F 10V	
C-140	Capacitor, Ceramic 39 pF 50V K SL	
C-141	- Not used -	
C-142	- Not used -	
C-143	Capacitor, Ceramic 0.001 μ F 50v M YD	
C-144	- Not used -	
C-145	Capacitor, Semi-conductor 0.047 μ F 25V K	
C-146	Capacitor, Semi-conductor 0.047 μ F 25V K	
C-147	Capacitor, Ceramic 0.0047 μ F 50V M YD	
C-148	Capacitor, Ceramic 0.01 μ F 50V Z YF	
C-149	Capacitor, Semi-conductor 0.047 μ F 25V K	
C-150	- Not used -	
C-151	- Not used -	
C-152	- Not used -	
C-153	Capacitor, Ceramic 0.047 μ F 50V Z ZF	
C-154	- Not used -	
C-155	Capacitor, Semi-conductor (SR) 0.01 μ F 25V K	
C-156	- Not used -	

REF. NO.	DESCRIPTION	DYNASCAN PART NO.
C-157	- Not used -	
C-158	- Not used -	
C-159	- Not used -	
C-160	Capacitor, Ceramic 0.0047 μ F 50V M YD	
C-161	Capacitor, Semi-conductor (SR) 0.047 μ F 25V K	
C-162	Capacitor, Ceramic 0.047 μ F 25V Z ZF	
C-163	Capacitor, Electrolytic 0.47 μ F 50V	
C-164	Capacitor, Ceramic 10 pF 50V D UJ	
C-501	Capacitor, Ceramic 33 pF 50V K SL	
DIODES		
D-1	Diode 1N60 AM	150-014-9-001
D-2	- Not used -	- Not used -
D-3	- Not used -	- Not used -
D-4	- Not used -	- Not used -
D-5	Diode 1N60 AM	150-014-9-001
D-6	Diode 1N60 AM	150-014-9-001
D-7	Diode 1S1555	151-028-9-007
D-8	Diode 1S2076A	151-101-9-001
D-9	Diode 1N60 AM	150-014-9-001
D-10	Diode 1S1555	151-028-9-007
D-11	Diode 1S1555	151-028-9-007
D-12	Diode 1S1555	151-028-9-007
D-13	- Not used -	- Not used -
D-14	Diode HZ6A-3	152-156-9-001
D-15	Diode 1S1555	151-028-9-007
D-16	Diode 1S1555	151-028-9-007
D-17	- Not used -	- Not used -
D-18	Diode 1SV73-EB	151-137-9-001
D-19	Diode 1N4003	151-083-9-001
D-20	Diode 1S1555	151-028-9-007
D-21	Diode 1S1555	151-028-9-007
D-22	Diode 1S1555	151-028-9-007
D-23	Diode 1S1555	151-028-9-007
D-24	Diode 1N60 P	150-006-9-001
D-25	Diode 1N60 P	150-006-9-001
D-26	Diode 1N60 P	150-006-9-001
D-27	Diode 1N60 P	150-006-9-001
D-28	Diode 1S1555	151-028-9-007
D-29	Diode 1S1555	151-028-9-007
D-30	Diode 1S1555	151-028-9-007
D-31	Diode 1S1555	151-028-9-007
D-32	Diode 1S1555	151-028-9-007
D-33	Diode 1S1555	151-028-9-007
D-34	Diode 1S1555	151-028-9-007
D-35	- Not used -	- Not used -
D-36	Diode 1S1555	151-028-9-007
D-37	Diode 1S1555	151-028-9-007
D-38	Diode 1S1555	151-028-9-007
D-39	Diode 1S1555	151-028-9-007
D-40	Diode 1S1555	151-028-9-007
D-41	Diode 1S1555	151-028-9-007
D-42	Diode 1S1555	151-028-9-007
D-43	Diode 1S1555	151-028-9-007
D-44	Diode 1S1555	151-028-9-007
D-351	Diode LED RT-242 PRS	158-070-9-003

REF. NO.	DESCRIPTION	DYNASCAN PART NO.
D-352	Diode LED RT-242-YS	158-070-9-004
D-353	Diode LED RT-242-YS	158-070-9-004
D-354	Diode LED RT-242 PRS	158-070-9-003
D-355	Diode LED RT-242 PRS	158-070-9-003
D-356	Diode LED RT-242 PRS	158-070-9-003
D-357	Diode LED RT-242 SGS	158-070-9-002
D-358	Diode LED RT-242 SGS	158-070-9-002
D-359	Diode LED RT-242 SGS	158-070-9-002
D-360	Diode LED RT-242 PRS	158-070-9-003
D-361	Diode LED RT-242 SGS	158-070-9-002
D-362	Diode LED RT-242 PRS	158-070-9-003
D-363	Diode LED RT-242 SGS	158-070-9-002
D-364	Diode LED RT-242 SGS	158-070-9-002
D-365	Diode LED RT-242 SGS	158-070-9-002
D-366	Diode LED RT-242 SGS	158-070-9-002
D-367	Diode LED RT-242 SGS	158-070-9-002
D-368	Diode LED RT-242 SGS	158-070-9-002
D-369	Diode LED RT-242 SGS	158-070-9-002
D-370	Diode LED RT-242 SGS	158-070-9-002
D-371	Diode LED LL-2253 YG	158-070-9-001
FILTER		
FT-1	Filter Crystal FL-055 10M-7A1	143-011-9-001
FT-2	Filter Ceramic FL-009 CFU 455H2	140-009-9-001
INTEGRATED CIRCUITS		
IC-1	Integrated Circuit UPC1242H	307-415-9-001
IC-2	Integrated Circuit SM5123A	307-415-9-004
IC-3	Integrated Circuit LB1710	307-415-9-003
IC-4	Integrated Circuit TA7310P-U	307-328-9-001
IC-5	Integrated Circuit LB1417	307-415-9-005
IC-6	Integrated Circuit HA17808W	307-415-9-002
JACKS		
J-1	-Not used-	-Not used-
J-2	-Not used-	-Not used-
J-3	Jack JK-089, HSJ0615	773-086-9-001
J-4	Jack JK-089, HSJ0615	773-086-9-001
J-351	Jack JK-328, 5551-10	777-050-9-007
J-352	Jack JK-328, 5551-16	777-050-9-008
J-353	Jack JK-328, 5551-07	777-050-9-006
J-501	Jack, ANT W/O LUG JK-230, M-BR-23D	777-050-9-004
J-502	Jack JK-325, 4S-L-D107	777-050-9-005
J-503	-Not used-	-Not used-
J-504	-Not used-	-Not used-
J-505	Jack JK-329	777-050-9-009
J-551	Jack JK-221, 10P	777-050-9-002
J-552	Jack JK-221, 16P	777-050-9-003
J-553	Jack JK-221, 7P	777-050-9-001

REF. NO.	DESCRIPTION	DYNASCAN PART NO.
COILS		
L-1	Coil LA-181 LIKAC-19073N	060-024-9-002
L-2	Coil LA-029 TKXN-22160BU	060-023-9-001
L-3	Coil LA-260 TKXC-25114N	060-030-9-014
L-4	Coil LA-120 TKAC-24073F	046-037-9-001
L-5	Coil LA-277 TKAC-25365N	046-025-9-004
L-6	Coil LA-163 RDC-42066N	060-022-9-001
L-7	Coil LA-204 RMC-41997N	046-024-9-003
L-8	Coil LA-165 VTKXNA-XT231ZO-TW	044-046-9-001
L-9	Coil LA-166 TKXC-18501N	066-025-9-005
L-10	Coil LE-096 8 1/2T	047-044-9-001
L-11	Coil LE-096 8 1/2T	047-044-9-001
L-12	Coil LC-074	044-040-9-002
L-13	Coil LD-168	041-083-9-003
L-14	Coil LE-151 C-7931 D4.0 6 1/2T	041-128-9-001
L-15	Coil LA-208 TKXC-24341AC	060-029-9-004
L-16	Coil LA-088 TKXC-24124N	066-019-9-002
L-17	Coil LA-260 TKXC-25114N	060-030-9-014
L-18	Coil LA-373 TKXC-28319Y	047-004-9-002
L-19	Coil LD-087-BF04-3*5*5*1	
RESISTORS		
NOTE:		
Resistor tolerance: J=±5% K=10%		
R-1	Resistor, Carbon Formed Vert 1M 1/8W J	
R-2	Resistor, Carbon Formed Vert 2.2K 1/8W J	
R-3	Resistor, Carbon Axial Lead 10K 1/8W J	
R-4	Resistor, Carbon Formed Vert 2.2M 1/8W J	
R-5	Resistor, Carbon Formed Vert 10K 1/8W J	
R-6	Resistor, Carbon Formed Vert 1K 1/8W J	
R-7	Resistor, Carbon Formed Vert 47K 1/8W J	
R-8	Resistor, Carbon Formed Vert 100K 1/8W J	
R-9	Resistor, Carbon Axial Lead 1.5K 1/6W J	
R-11	Resistor, Carbon Formed Vert 1K 1/8W J	
R-12	Resistor, Carbon Axial Lead 3.3K 1/8W J	
R-13	Resistor, Carbon Formed Vert 15K 1/8W J	
R-14	Resistor, Carbon Formed Vert 100 1/8W J	
R-15	Resistor, Carbon Formed Vert 6.8K 1/8W J	
R-16	Resistor, Carbon Axial Lead 3.3K 1/8W J	
R-17	Resistor, Carbon Axial Lead 100 1/8W J	
R-18	Resistor, Carbon Axial Lead 470 1/8W J	
R-19	Resistor, Carbon Formed Vert 470 1/8W J	
R-20	-Not used-	
R-21	Resistor, Carbon Formed Vert 680 1/8W J	
R-22	Resistor, Carbon Formed Vert 10K 1/8W J	
R-23	Resistor, Carbon Formed Vert 2.2K 1/8W J	
R-24	Resistor, Carbon Formed Vert 1K 1/8W J	
R-25	Resistor, Carbon Formed Vert 68K 1/8W J	
R-26	Resistor, Carbon Formed Vert 100 1/8W J	
R-27	Resistor, Carbon Formed Vert 2.2K 1/8W J	
R-28	Resistor, Carbon Formed Vert 1K 1/8W J	
R-29	Resistor, Carbon Formed Vert 47K 1/8W J	
R-30	Resistor, Carbon Formed Vert 10 1/8W J	
R-31	Resistor, Carbon Formed Vert 2.2K 1/8W J	

REF. NO.	DESCRIPTION	DYNASCAN PART NO.
R-32	Resistor, Carbon Formed Vert 100 1/8W J	
R-33	Resistor, Carbon Formed Vert 47 1/8W J	
R-34	Resistor, Carbon Formed Vert 68K 1/8W J	
R-35	Resistor, Carbon Axial Lead 68K 1/8W J	
R-36	Resistor, Carbon Axial Lead 56K 1/8W J	
R-37	Resistor, Carbon Formed Vert 3.3K 1/8W J	
R-38	Resistor, Carbon Axial Lead 470 1/8W J	
R-39	Resistor, Carbon Formed Vert 560K 1/8W J	
R-40	-Not used-	
R-41	Resistor, Carbon Formed Vert 82K 1/8W J	
R-42	Resistor, Carbon Formed Vert 68K 1/8W J	
R-43	Resistor, Carbon Formed Vert 3.3M 1/8W J	
R-44	Resistor, Carbon Formed Vert 1K 1/8W J	
R-45	Resistor, Carbon Formed Vert 1K 1/8W J	
R-46	Resistor, Carbon Formed Vert 22K 1/8W J	
R-47	Resistor, Carbon Axial Lead 220 1/8W J	
R-48	Resistor, Carbon Formed Vert 10K 1/8W J	
R-49	Resistor, Carbon Formed Vert 10K 1/8W J	
R-50	-Not used-	
R-51	Resistor, Carbon Formed Vert 10K 1/8W J	
R-52	Resistor, Carbon Formed Vert 10K 1/8W J	
R-53	-Not used-	
R-54	Resistor, Carbon Formed Vert 1.5K 1/8W J	
R-55	Resistor, Carbon Formed Vert 820 1/8W J	
R-56	Resistor, Carbon Formed Vert 56 1/8W J	
R-57	Resistor, Carbon Formed Vert 270 1/8W J	
R-58	Resistor, Carbon Formed Vert 1.5K 1/8W J	
R-59	Resistor, Carbon Formed Vert 1.5M 1/8W J	
R-60	Resistor, Carbon Formed Vert 3.3K 1/8W J	
R-61	Resistor, Carbon Axial Lead 3.3K 1/8W J	
R-62	Resistor, Carbon Formed Vert 1.5K 1/8W J	
R-63	Resistor, Carbon Formed Vert 4.7K 1/8W J	
R-64	Resistor, Carbon Formed Vert 10K 1/8W J	
R-65	Resistor, Carbon Formed Vert 3.3K 1/8W J	
R-66	Resistor, Carbon Formed Vert 100 1/8W J	
R-67	Resistor, Carbon Formed Vert 10K 1/8W J	
R-68	Resistor, Carbon Axial Lead 1.5K 1/8W J	
R-69	Resistor, Carbon Formed Vert 82 1/8W J	
R-70	Resistor, Carbon Formed Vert 10K 1/8W J	
R-71	Resistor, Carbon Formed Vert 330 1/8W J	
R-72	Resistor, Carbon Formed Vert 82K 1/8W J	
R-73	Resistor, Carbon Formed Vert 2.7K 1/8W J	
R-74	Resistor, Carbon Axial Lead 22K 1/8W J	
R-75	Resistor, Carbon Axial Lead 330 1/8W J	
R-76	Resistor, Carbon Formed Vert 39K 1/8W J	
R-77	Resistor, Carbon Formed Vert 4.7K 1/8W J	
R-78	Resistor, Carbon Formed Vert 390K 1/8W J	
R-79	Resistor, Carbon Formed Vert 1.5K 1/8W J	
R-80	-Not used-	
R-81	Resistor, Carbon Formed Vert 1.5 1/8W J	
R-82	Resistor, Carbon Formed Vert 22K 1/8W J	
R-83	Resistor, Carbon Formed Vert 56K 1/8W J	
R-84	Resistor, Carbon Formed Vert 10K 1/8W J	
R-85	Resistor, Carbon Formed Vert 3.3K 1/8W J	
R-86	Resistor, Carbon Formed Vert 2.7K 1/8W J	
R-87	Resistor, Carbon Formed Vert 3.3K 1/8W J	
R-88	Resistor, Carbon Formed Vert 1M 1/8W J	
R-89	Resistor, Carbon Formed Vert 1K 1/8W J	

REF. NO.	DESCRIPTION	DYNASCAN PART NO.
R-90	Resistor, Carbon Axial Lead 39K 1/8W J	
R-91	Resistor, Carbon Axial Lead 10 1/8W J	
R-92	Resistor, Carbon Axial Lead 680 1/8W J	
R-93	Resistor, Carbon Formed Vert 56K 1/8W J	
R-94	Resistor, Carbon Formed Vert 330 1/8W J	
R-95	Resistor, Carbon Formed Vert 1K 1/8W J	
R-96	Resistor, Carbon Formed Vert 10 1/8W J	
R-97	Resistor, Carbon Formed Vert 100 1/8W J	
R-98	Resistor, Carbon Formed Vert 100 1/8W J	
R-99	Resistor, Carbon Axial Lead 100 1/8W J	
R-100	-Not used-	
R-101	Resistor, Carbon Formed Vert 100 1/8W J	
R-102	Resistor, Carbon Formed Vert 100 1/8W J	
R-103	Resistor, Carbon Formed Vert 100 1/8W J	
R-104	Resistor, Carbon Axial Lead 100 1/8W J	
R-105	Resistor, Carbon Formed Vert 22K 1/8W J	
R-106	Resistor, Carbon Formed Vert 10K 1/8W J	
R-107	Resistor, Carbon Axial Lead 2.2K 1/2W J	
R-108	Resistor, Carbon Formed Vert 150 1/8W J	
R-109	Resistor, Carbon Formed Vert 120 1/8W J	
R-100	-Not used-	
R-111	Resistor, Carbon Axial Lead 150 1/8W J	
R-112	Resistor, Carbon Axial Lead 100 1/8W J	
R-113	Resistor, Carbon Formed Vert 560 1/8W J	
R-114	Resistor, Carbon Axial Lead 560 1/8W J	
R-115	Resistor, Carbon Formed Vert 2.2 1/8W J	
R-116	Resistor, Carbon Axial Lead 10 1/8W J	
R-117	Resistor, Carbon Formed Vert 27 1/8W J	
R-118	Resistor, Carbon Formed Vert 27 1/8W J	
R-119	Resistor, Carbon Formed Vert 330 1/8W J	
R-120	-Not used-	
R-121	Resistor, Carbon Formed Vert 1.5K 1/8W J	
R-122	Resistor, Carbon Formed Vert 220 1/8W J	
R-123	Resistor, Carbon Axial Lead 100 1/8W J	
R-124	Resistor, Carbon Formed Vert 560 1/8W J	
R-125	Resistor, Carbon Formed Vert 10K 1/8W J	
R-126	Resistor, Carbon Formed Vert 1.5K 1/8W J	
R-127	Resistor, Carbon Formed Vert 3.3K 1/8W J	
R-128	Resistor, Carbon Formed Vert 100K 1/8W J	
R-129	Resistor, Carbon Formed Vert 2.2K 1/8W J	
R-130	-Not used-	
R-131	Resistor, Carbon Formed Vert 47K 1/8W J	
R-132	Resistor, Carbon Formed Vert 2.2K 1/8W J	
R-133	Resistor, Carbon Formed Vert 1.5K 1/8W J	
R-134	Resistor, Carbon Axial Lead 3.3K 1/8W J	
R-135	Resistor, Carbon Formed Vert 2.7K 1/8W J	
R-136	Resistor, Carbon Formed Vert 10K 1/8W J	
R-137	Resistor, Carbon Formed Vert 39K 1/8W J	
R-138	Resistor, Carbon Formed Vert 2.2K 1/8W J	
R-139	Resistor, Carbon Formed Vert 2.2K 1/8W J	
R-140	-Not used-	
R-141	Resistor, Carbon Formed Vert 100K 1/8W J	
R-142	Resistor, Carbon Formed Vert 10K 1/8W J	
R-143	Resistor, Carbon Axial Lead 820K 1/8W J	
R-144	Resistor, Carbon Axial Lead 220 1/8W J	
R-145	Resistor, Carbon Axial Lead 220 1/8W J	
R-146	Resistor, Carbon Axial Lead 220 1/8W J	
R-147	Resistor, Carbon Axial Lead 330 1/8W J	

REF. NO.	DESCRIPTION	DYNASCAN PART NO.
R-148	Resistor, Carbon Axial Lead 330 1/8W J	011-002-5-150 011-102-5-279
R-149	Resistor, Carbon Axial Lead 470 1/8W J	
R-150	Resistor, Carbon Formed Vert 5.6K 1/8W J	
R-151	Resistor, Carbon Axial Lead 470 1/8W J	
R-152	Resistor, Carbon Axial Lead 470 1/8W J	
R-153	Resistor, Carbon Axial Lead 100 1/8W J	
R-154	Resistor, Carbon Formed Vert 6.8K 1/8W J	
R-155	Resistor, Carbon Axial Lead 10K 1/8W J	
R-156	Resistor, Carbon Formed Vert 1K 1/8W J	
R-157	Resistor, Carbon Formed Vert 1.5K 1/8W J	
R-158	Resistor, Carbon Formed Vert 100 1/8W J	
R-159	Resistor, Carbon Formed Vert 10K 1/8W J	
R-160	-Not used-	
R-161	Resistor, Carbon Axial Lead 2.2K 1/8W J	
R-162	Resistor, Carbon Formed Vert 10K 1/8W J	
R-163	Resistor, Carbon Axial Lead 1K 1/8W J	
R-164	Resistor, Carbon Formed Vert 10K 1/8W J	
R-165	Resistor, Carbon Formed Vert 33K 1/8W J	
R-166	Resistor, Carbon Axial Lead 1K 1/8W J	
R-167	Resistor, Carbon Formed Vert 10K 1/8W J	
R-168	Resistor, Carbon Formed Vert 330 1/8W J	
R-169	Resistor, Carbon Formed Vert 220 1/8W J	
R-170	-Not used-	
R-171	Resistor, Metal Oxide, 15 2W J	
R-172	Resistor, Metal Oxide, 2.7 2W J	
R-173	Resistor, Carbon Formed Vert 47 1/8W J	
R-174	Resistor, Carbon Axial Lead 68 1/8W J	
R-175	Resistor, Carbon Formed Vert 10K 1/8W J	
R-176	Resistor, Carbon Axial Lead 3.3K 1/8W J	
R-177	-Not used-	
R-178	-Not used-	
R-179	-Not used-	
R-180	Resistor, Carbon Formed Vert 68K 1/8W J	
R-181	Resistor, Carbon Formed Vert 4.7M 1/8W J	
R-182	Resistor, Carbon Formed Vert 1.5K 1/6W J	
R-351	Resistor, Carbon Formed Vert 220 1/6W J	
R-352	Resistor, Carbon Formed Vert 220 1/6W J	
R-353	Resistor, Carbon Formed Vert 220 1/6W J	
R-551	Resistor, Carbon Axial Lead 330 1/6W J	
R-552	Resistor, Carbon Axial Lead 220 1/6W J	
R-553	Resistor, Carbon Axial Lead 100 1/6W J	
R-554	Resistor, Carbon Axial Lead 100 1/6W J	
R-555	Resistor, Carbon Axial Lead 220 1/6W J	
R-556	Resistor, Carbon Formed Vert 220 1/6W J	
R-557	Resistor, Carbon Axial Lead 10K 1/6W J	
R-558	Resistor, Carbon Axial Lead 18K 1/6W J	
R-559	Resistor, Carbon Axial Lead 8.2K 1/6W J	
SWITCHES		
S-351 S-352 S-503 S-504	Switch Tact SW-539 M-6050 Switch Tact SW-539 M-6050 Switch Push SW-539 Switch, Rotary SR-353	088-147-9-001 083-312-9-001

REF. NO.	DESCRIPTION	DYNASCAN PART NO.
TRANSFORMER		
T-1	Transformer, Output TF-177	061-050-9-001
T-2	Transformer, AF Choke TF-083	042-021-9-001
TRANSISTORS		
TR-1	Transistor DB-259 2SC1675-L	176-065-9-001
TR-2	Transistor DB-259 2SC1675-L	176-065-9-001
TR-3	Transistor DB-224 2SC945A-Q	176-062-9-001
TR-4	Transistor DB-003 2SA733-P	177-020-9-001
TR-5	Transistor DB-224 2SC945A-Q	176-062-9-001
TR-6	Transistor DB-259 2SC1675-L	176-065-9-001
TR-7	Transistor DB-259 2SC1675-L	176-065-9-001
TR-8	Transistor DB-295 2SC1674-L	176-081-9-002
TR-9	Field Effect Transistor DC-019 2SK192A-BL	182-076-9-001
TR-10	Transistor DB-259 2SC1675-L	176-065-9-001
TR-11	Transistor DB-259 2SC1675-L	176-065-9-001
TR-12	Transistor DB-301 2SC941TM-O	176-089-9-004
TR-13	Transistor DB-224 2SC945A-Q	176-062-9-001
TR-14	Transistor DB-224 2SC945A-Q	176-062-9-001
TR-15	Transistor DB-224 2SC945A-Q	176-062-9-001
TR-16	Transistor DB-224 2SC945A-Q	176-062-9-001
TR-17	Transistor DB-224 2SC945A-Q	176-062-9-001
TR-18	Transistor DB-106 2SB525-C	177-045-9-001
TR-19	Transistor DB-003 2SA733-P	177-020-9-001
TR-20	Transistor DB-106 2SB525-C	177-045-9-001
TR-21	Transistor DB-383 2SC3242A-E	176-191-9-001
TR-22	Transistor DB-224 2SC945A-Q	176-062-9-001
TR-23	Transistor DB-259 2SC1675-L	176-065-9-001
TR-24	Transistor DB-259 2SC1675-L	176-065-9-001
TR-25	Transistor DB-259 2SC1675-L	176-065-9-001
TR-26	Transistor DB-224 2SC945A-Q	176-062-9-001
TR-27	Transistor DB-224 2SC945A-Q	176-062-9-001
TR-28	Transistor DB-228 2SC2086-D	176-108-9-002
TR-29	Transistor DB-301 2SC941TM-O	176-089-9-004
TR-30	Transistor DB-224 2SC945A-Q	176-062-9-001
TR-31	Transistor DB-003 2SA733-P	177-020-9-001
TR-32	Transistor DB-224 2SC945A-Q	176-062-9-001
TR-33	Transistor DB-224 2SC945A-Q	176-062-9-001
TR-34	Transistor DB-003 2SA733-P	177-020-9-001
TR-35	Transistor DB-224 2SC945A-Q	176-062-9-001
TR-36	Transistor DB-224 2SC945A-Q	176-062-9-001
TR-37	Transistor DB-003 2SA733-P	177-020-9-001
TR-38	Transistor DB-224 2SC945A-Q	176-062-9-001
TR-39	Transistor DB-383 2SC3242A-E	176-191-9-001
TR-40	Transistor DB-003 2SA733-P	177-020-9-001
TR-41	Transistor DB-003 2SA733-P	177-020-9-001
TR-501	Transistor DB-331 2SC2166-C	176-108-9-001
VARIABLE RESISTORS		
VR-1	Resistor, Semi-fixed RT-182 TT24R 200KB	008-465-9-005
VR-2	Resistor, Semi-fixed RT-182 TT24R 50KB	008-465-9-003
VR-3	Resistor, Semi-fixed RT-182 TT24R 200KB	008-465-9-005
VR-4	Resistor, Semi-fixed RT-182 TT24R 100KB	008-465-9-003
VR-5	Resistor, Semi-fixed RT-182 TT24R 50KB	008-843-9-001

VOLTAGE CHART

Measurement Conditions:

Power supply voltage:	13.8 V
ANT output impedance:	50 ohms
Test Temperature	25°C
SSG Modulation:	1 kHz, 30%
SSG Output level:	0 dB 0.5 V
Standard audio Output	0.5W
Standard output frequency	1 kHz
Audio load:	8 ohms
Measurement channel:	19 CH (27.185 MHz)

Unless otherwise specified, set controls as follows:

A N L:	OFF
N B:	OFF
P A:	OFF
D I M:	OFF
C H 9:	OFF
VOLUME:	MAX
SQUELCH:	MIN
DYNAMIKE:	MAX
RF GAIN:	MAX
S/RF/MOD/CAL/SWR:	S/RF

MECHANICAL PARTS LIST

REF. NO.	DESCRIPTION	DYNASCAN PART NO.
1	Panel, Front ABS, Black	380-538-9-001
2	Control Plate ABS,CR	380-538-9-002
3	Window AS, Gray Smoke	380-538-9-003
4	Support ABS, Black	380-538-9-004
5	LED Housing ABS, Vanilla White	380-538-9-005
6	Screw, Mounting ABS INST CLR,Black	634-204-9-001
7	Button, Push (ANL) ABS, CR, SILK PRINT	384-075-9-001
8	Button, Push (NB) ABS, CR, SILK PRINT	384-075-9-002
9	Button, Push (PA) ABS, CR, SILK PRINT	384-075-9-003
10	Button, Push (DIM) ABS, CR, SILK PRINT	384-075-9-004
11	Button, Push (CH19) ABS, CR, SILK PRINT	384-075-9-005
12	Button, Push (CH 9) ABS, CR, SILK PRINT	384-075-9-006
13	Button, Push (DOWN) ABS, CR, SILK PRINT	384-075-9-007
14	Button, Push (UP) ABS, CR, SILK PRINT	384-075-9-008
15	Knob ABS, CR	751-313-9-001
16	Mounting Bracket SPCC, 1.6T, Black	250-198-9-001
17	Cover, Bottom VINYTOP, SB-K08,1.0T, Black	252-054-9-001
18	Cover, Top VINYTOP, SB-K08,1.0T, Black	253-134-9-001
19	Hanger, Microphone SPCC, 1.0T, NI	741-074-9-001
20	Display Plate MYLAR 0.35T	600-166-9-002
21	Chassis SPCC, 1.0T, ZMC	
22	Holder, IC (B)	SECC,1T Non Oil
23	Holder, IC (A)	ALP,2T Non Oil
24	Holder, Switch	SECC, 1.0T
25	Shield Plate	ALP, 0.1T
26	Shield Plate	ALP, 0.1T
27	ID Plate, FCC	ALP, 0.5T
28	Washer, Rubber, Neoprene, Black, 7. 15. 2.0T	
29	Wool-coated Paper, Wool Tack, Wool Paper, 10. 150. 0.3T	
30	Insulation Plate	MYLAR 0.1T
31	Screw, Flat HD +	M3×5 NI
32	Screw, Bind HD +	M3×8 BNI
33	Screw, Bind HD +	M3×8 NI
34	Screw, Bind HD +	M3×12 NI
35	Screw, Tapping Round HD +	D3.5×8 NI
36	Screw, Tapping Round HD +	D5×10 NI
37	Screw, Taptight Bind HD +	M3×6 BNI
38	Screw, Taptight Bind HD +	M3×6 NI
39	Hex Nut	M3.0 NI
40	Nut Flange	M3 2MC
41	Washer, Lock	D3.5 NI
42	Washer, Star	D5 NI
43	Screw, P Tight Bind HD +	D3×8 NI
44	Screw, P Tight Bind HD +	D3×8 NI
45	Screw, P Tight Bind HD +	D3×8 NI
46	Spring Plate, Knob	D6
47	Rivet, AL, ID Plate	D3.2×3.2
48	Washer SPT. 0.35T	
49	Spacer, Connector PVC 0.5T	
50	Spacer Wool Tack, 0.3T, Black	

EXPLODED VIEW

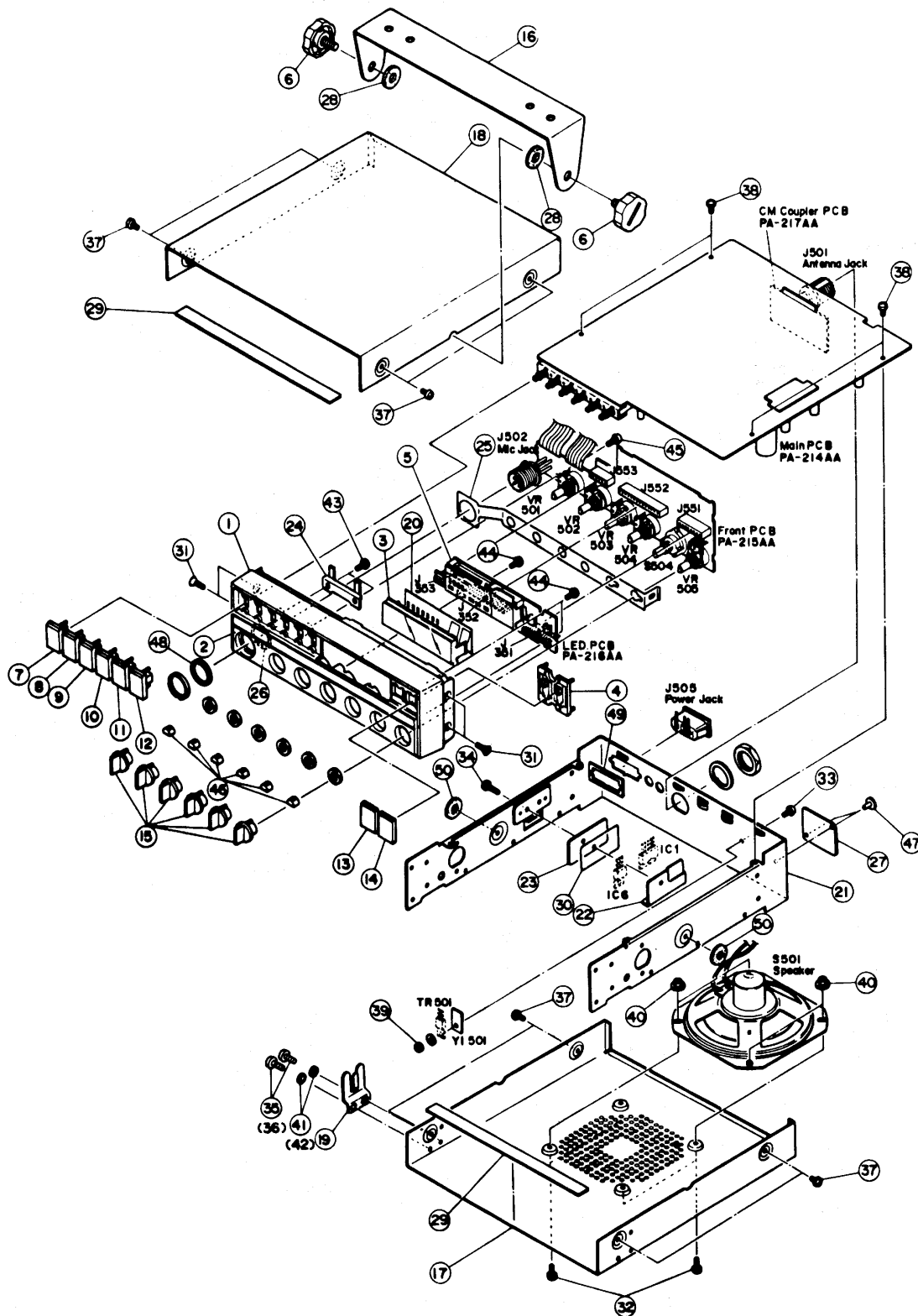

TRANSISTOR VOLTAGE CHART

TR No.	TR. NAME		RX (V)			TX (V)			
			B	E	C	B	E	C	
1	2SC1675L	NB	OFF	0	0	0	0	0	0
			ON	0.4	0	7	0.4	0	6.9
2	2SC1675L	NB	OFF	0	0	0	0	0	0
			ON	6.8	6.1	8.2	6.8	6.1	8.2
3	2SC945AQ	NB	OFF	0	0	0	0	0	0
			ON	6.1	0	4.7	6.1	04.7	
4	2SA733P	NB	OFF	0	0	0	0	0	0
			ON	8.3	8.3	0	8.3	8.3	0
5	2SC945AQ	NB	OFF	0	0	0	0	0	0
			ON	0	0	0	0	0	0
6	2SC1675L			0	0	0	0	0	0
7	2SC1675L			0.2	0	0	0	0	0
8	2SC1674L			1.2	0.5	7.3	0.2	0.2	1
9	2SK192ABL			0.1(G)	7.4(D)	4(S)	0(G)	1.1(D)	1.1(S)
10	2SC1675L			0.9	0.4	7.6	0.1	0	1.1
11	2SC1675L			0.7	0	2.5	0.1	0	1
12	2SC941TM(0)			2.5	2	12.5	1	0.4	12.5
13	2SC945AQ	SQ	MIN	0	0	0.7	0	0	0.7
			MAX	0.6	0	0	0.6	0	0
14	2SC945AQ	SQ	MIN	0	0	0	0	0	0
			MAX	0.7	0	0	0.7	0	0
15	2SC945AQ	SQ	MIN	0.7	0	0	0.7	0	0
			MAX	0	0	4.7	0	0	4.7
16	2SC945AQ			0.7	0	0.1	0.2	0	5
17	2SC945AQ			0	0.2	7.6	0	0	1.1
18	2SB525C	DIM	OFF	4	4.3	2	4	4.3	2
			ON	2.7	3	1.5	2.7	3	1.5
19	2SA733P	DIM	OFF	4.5	4.2	4	4.5	4.2	4
			ON	4	3	2.5	4	3	2.5
20	2SB525C	DIM	OFF	4.5	4.3	2	4.5	4.3	2
			ON	4	3	1.5	4	3	1.5
21	2SC3242AE	DIM	OFF	5	4.5	8.4	5	4.5	8.4
			ON	3.5	3	8	3.5	3	8
22	2SC945AQ			0.7	0	0	0.7	0	0
23	2SC1675L			5	5.2	7.5	5	5.2	7.5
24	2SC1675L			6	6	7	6	6	7
25	2SC1675L			0.3	0	5.5	0.3	0	5.5
26	2SC945AQ			0.1	0	0	0.6	0	0
27	2SC945AQ			0.1	0.5	4	0	0	0.8
28	2SC2086D			0	0	14	0	0	12
29	2SC941TM(0)	PA	OFF	0.5	7.5	14	3	2.5	12.5
			ON	0.5	7.5	0	1.3	0.7	0.6

TR No.	TR. NAME		RX (V)			TX (V)			
			B	E	C	B	E	C	
30	2SC945AQ		8.4	7.5	8.2	1.1	1.1	8.5	
31	2SA733P		8	8.4	1.1	7.5	8	8	
32	2SC945AQ		2	1.5	4.5	2	1.5	4.5	
33	2SC945AQ		0.7	0	0	0.2	0	0	
34	2SA733P		3.5	4	0.5	3.5	4	0.2	
35	2SC945AQ		0	0	8.4	0.9	0.8	8.4	
36	2SC945AQ		0	0	8	0.1	0.8	8	
37	2SA733P		8	8.4	0	8	8.4	0	
38	2SC945AQ		0.6	0	0	0.6	0	0	
39	2SC3242AE	DIM	OFF	7.4	6.8	8.2	7.2	6.6	8.2
			ON	4.6	4	8.2	4.6	4	8.2
40	2SA733P	DIM	OFF	6	6.8	6.8	6.4	6.8	0
			ON	3.5	4	4	3.8	4	0
41	2SA733P	DIM	OFF	1.5	2.4	0	7	5	0
			ON	0.6	1.3	0	7	2.5	0
501	2SC2166C		0	0	13	0	0	12	

IC VOLTAGE CHART

IC No.	IC NAME	IC PIN No.	RX (V)	TX (V)
1	μPC1242H	1	0	0
		2	1.8	1.8
		3	1.3	1.3
		4	0	0
		5	0	0
		6	7.2	7
		7	12.5	13
		8	13.5	13
2	SM5123A	1	2.9	2.9
		2	2.9	2.9
		3	0.2	0.2
		4	2.9	2.9
		5	2.9	2.9
		6	2.9	2.9
		7	5.4	5.4
		8	2.9	2.9
		9	0	0
		10	3	3
		11	2.9	2.9
		12	0	0
		13	1	1
		14	5.6	5.6
		15	0	0
		16	5.6	5.6
		17	2	3.2
		18	5.6	5.6
		19	4.5	2.6
		20	4.5	4.5
		21	4.5	4.5
		22	4.5	4.5
		23	4.5	4.5
		24	0	0
3	LB1710	1	2.9	2.9
		2	5.4	5.4
		3	2.9	2.9
		4	2.9	2.9
		5	2.9	2.9
		6	0.2	0.2
		7	2.9	2.9
		8	0	0
		9	5.6	5.6
		10	1.6	1.6

IC No.	IC NAME	IC PIN No.	RX (V)	TX (V)
3	LB1710	11	0.7	0.7
		12	1.6	1.6
		13	1.6	1.6
		14	1.6	1.6
		15	2.6	2.6
		16	1.6	1.6
4	TA7310P μ	1	2.4	2.4
		2	2	2
		3	1.2	1.2
		4	1.7	1.7
		5	0	0
		6	1	8
		7	2	2
		8	4	4.5
		9	1.2	6.5
5	LB1417	1	8	8
		2	3	3
		3	3	3
		4	0	0.2
		5	0	0.4
		6	0.1	4
		7	0	0
		8	5	0.5
		9	5	0.6
		10	5	0.6
		11	5	0.4
		12	5	0.4
		13	5	0.3
		14	5	0.3
6	HA17808W	1	8.2	8.2
		2	0	0
		3	13.5	13.5

SEMI-CONDUCTOR LEAD IDENTIFICATION

Diodes A: ANODE
C: CATHODE

IN60AM
IN60P
IS2076A
IN4003
IS1555
ISV73-EB
HZ6A3

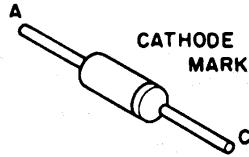

RT-242 PRS
RT-242 YS



Transistors B: BASE
C: COLLECTOR
E: EMITTER

2SA733A-P
2SC941TM-O
2SC945A-Q
2SC1674-L
2SC1675-L
2SC3242A-E

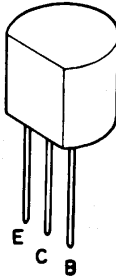

2SB525-C
2SC2086-D

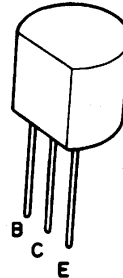

2SC2166-C

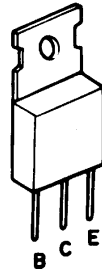

FET D: DRAIN
S: SOURCE
G: GATE

2SK192A-BL

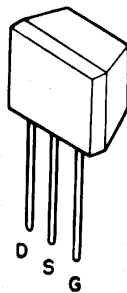

LL-2253YG

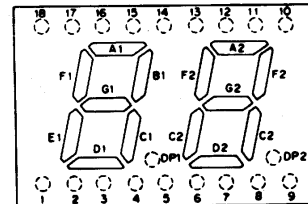

COMMON ANODE

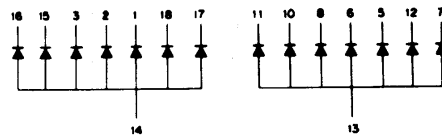

Pin no	Function	Pin no	Function
1	E1 Cathode	10	B2 Cathode
2	D1 Cathode	11	A2 Cathode
3	C1 Cathode	12	F2 Cathode
4	NC Cathode	13	DIGIT 2 Anode
5	E2 Cathode	14	DIGIT 1 Anode
6	D2 Cathode	15	B1 Cathode
7	G2 Cathode	16	A1 Cathode
8	C2 Cathode	17	G1 Cathode
9	NC Cathode	18	F1 Cathode

IC INTERNAL DIAGRAMS

TA7310P-U

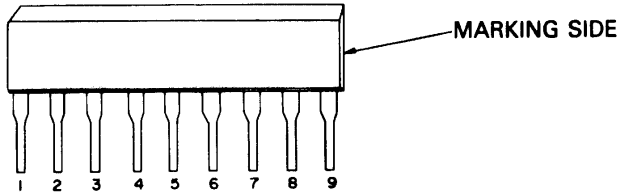
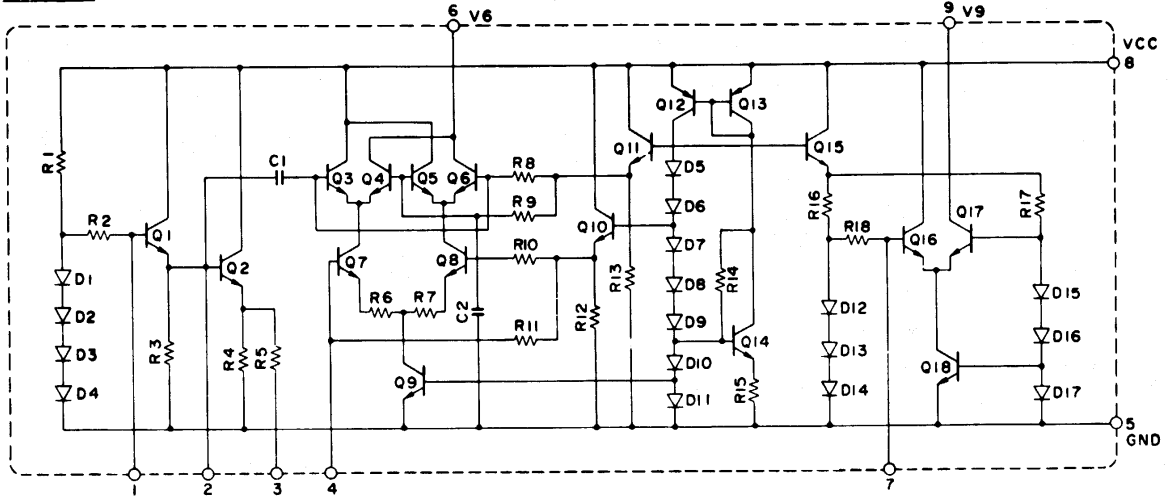

μPC1242H

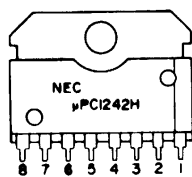

NO	μPC1242H
1	INPUT
2	RIPPLE FILTER
3	N. F. B.
4	GND
5	GND
6	OUTPUT
7	BOOTSTRAP
8	V+

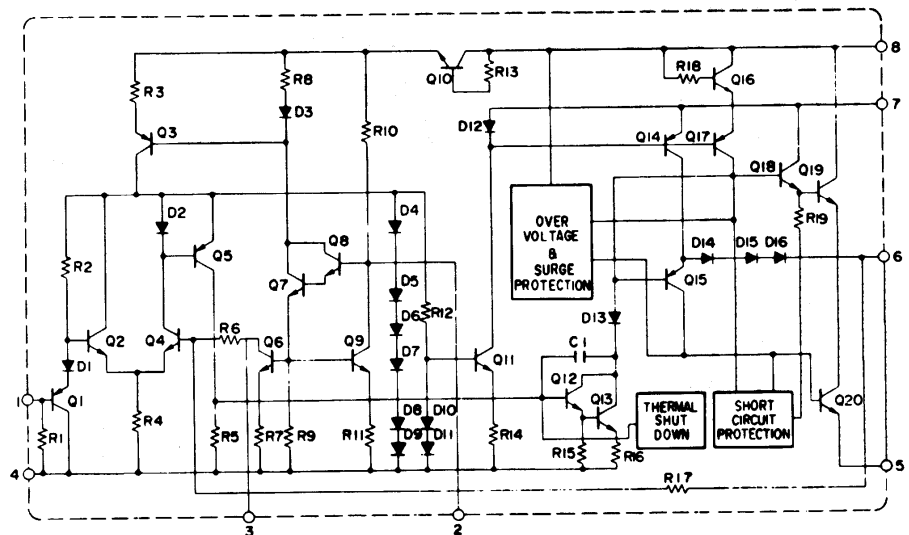

HA17808W

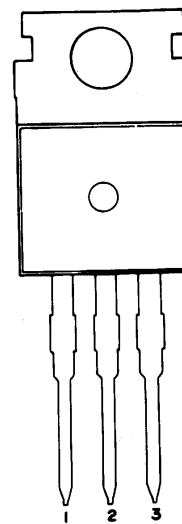
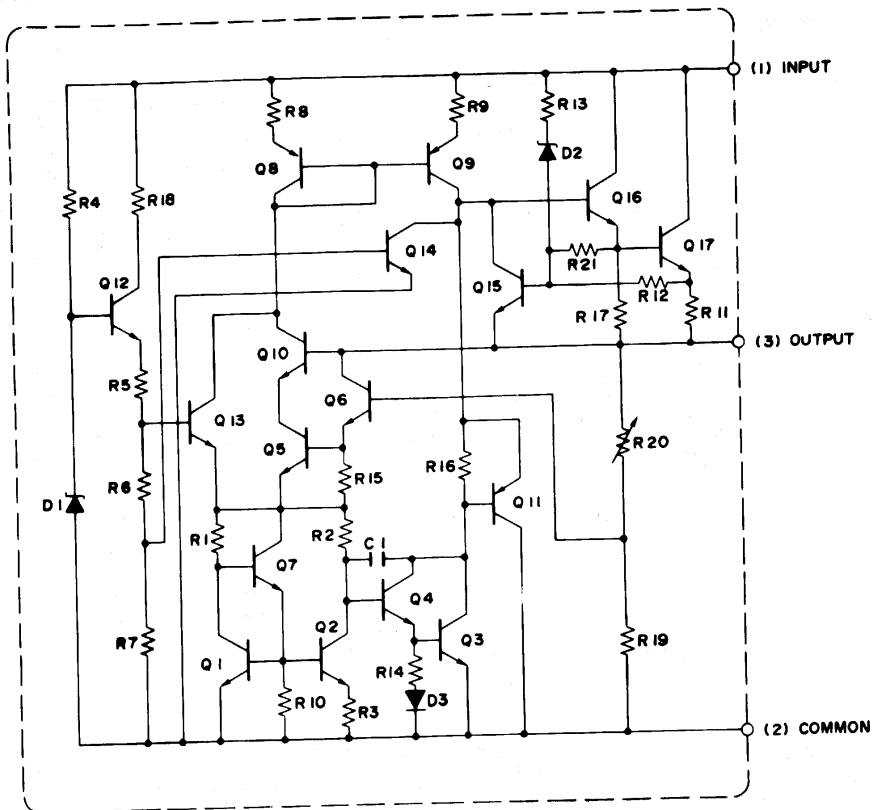

LB1710

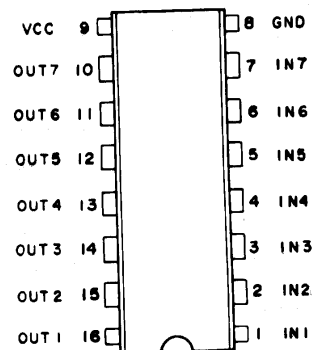
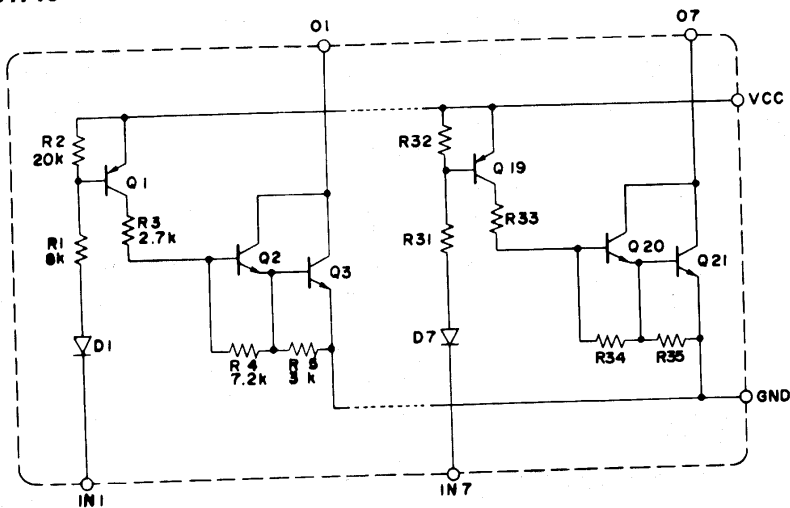

SM5123A

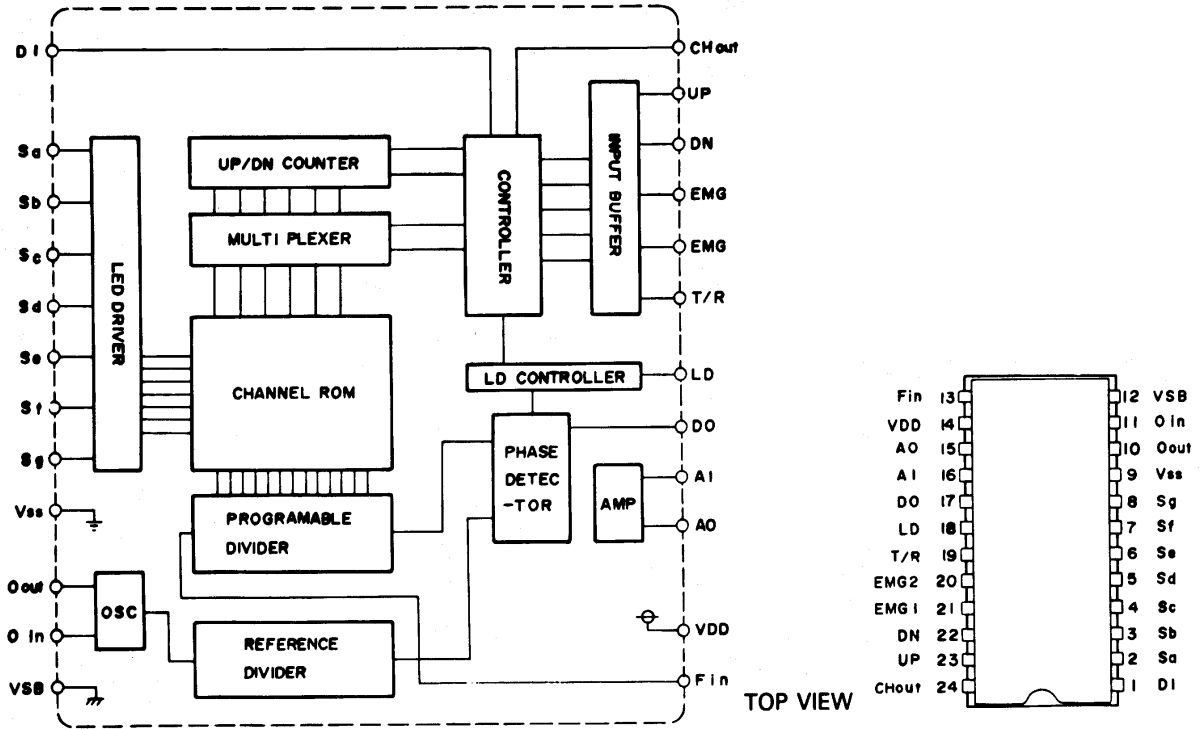

LB1417

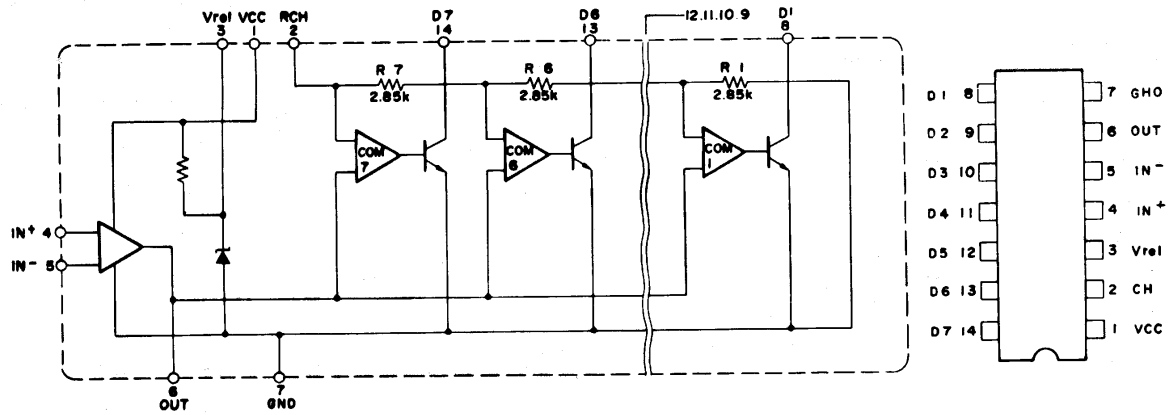

SCHEMATIC DIAGRAM 29 PLUS

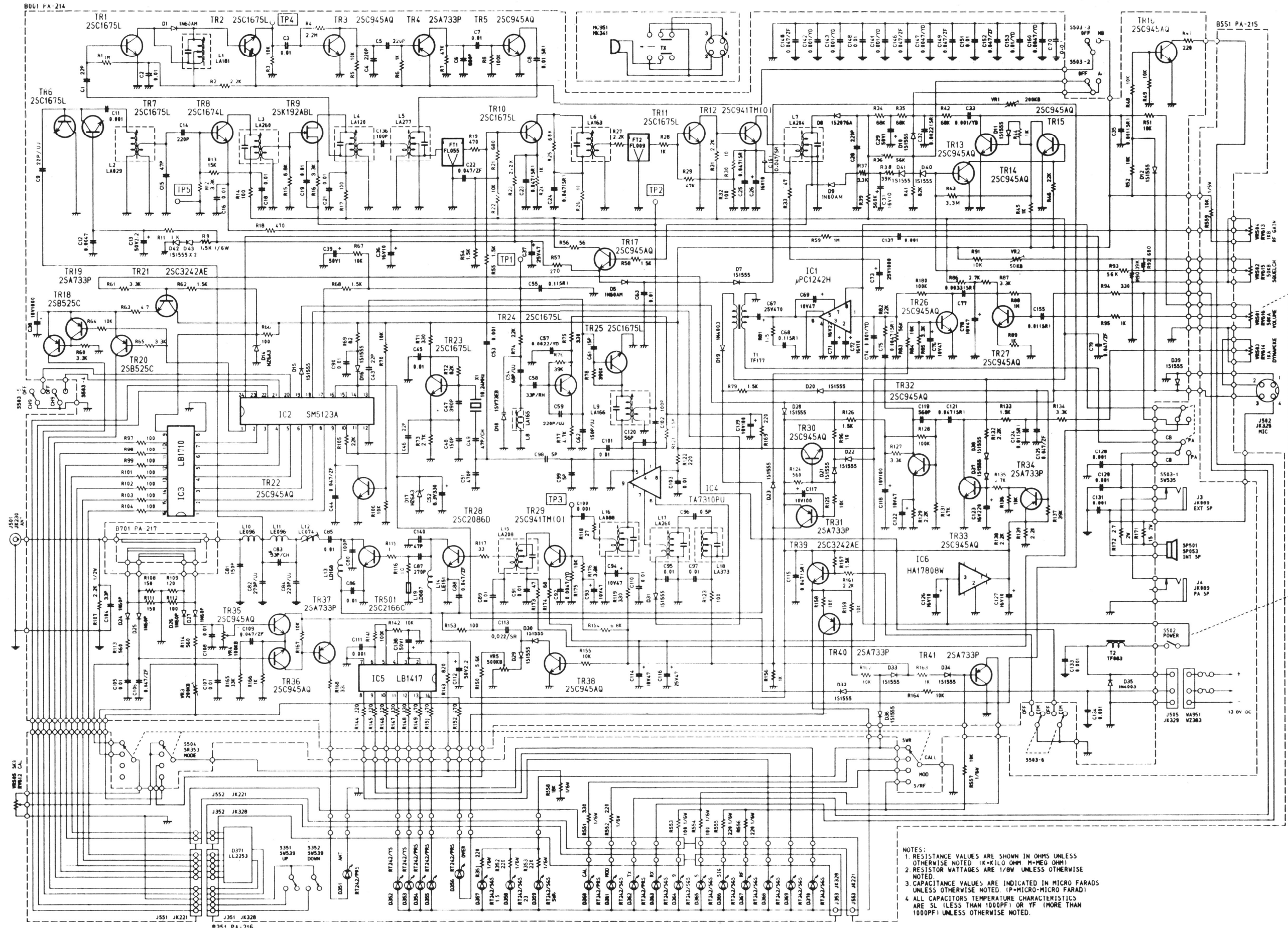

Reference No.	Manufacturer's Part Number	DYNASCAN Part Number	Reference No.	Manufacturer's Part Number	DYNASCAN Part Number
DC01,005,006	BDAY0001001	150-014-9-001	L007	BLAY0204001	046-024-9-003
DC04-027	BDAY0001002	150-006-9-001	L015	BLAY0208001	060-029-9-004
D008	BDAY0131001	151-101-9-001	L003-017	BLAY0260001	060-030-9-014
D009,005	BDAY0133001	151-083-9-001	L005	BLAY0277001	046-025-9-004
D007,009-012,015, 016,020-023,029	BDAY0181001	151-028-9-007	L018	BLAY-373001	047-004-9-002
D018	BDAY0220001	151-137-9-001	L012	BLCY0074001	044-040-9-002
D014,017	BDAY0269005	152-156-9-001	L013	BLDY0033001	041-083-9-003
D371	BDAY0347001	158-070-9-001	L010,011	BLEY0096001	047-044-9-001
D357-359,D361, 363-370	BDAY0348001	158-070-9-002	L014	BLEY0151001	041-128-9-001
D351,354-356, 360,362	BDAY0349001	158-070-9-003	MC951	BMKY0341001	561-008-9-001
D352,353	DBAY0350001	158-070-9-004	B351	BPAY0216AAZ	302-940-9-001
TR004,019,031, 034,037,040,041	BDBA0733115	177-020-9-001	B701	BPAY0217AAZ	302-941-9-001
TR018,020	BDBB0525103	177-045-9-001	X001	BQXY0074001	132-027-9-001
TR012,029	BDBC0941523	176-089-9-004	R171	BRSJ201504Z	011-002-5-150
TR003,005,013-017, 022,026,027,030, 032,033,035,036,038	BDBC0945507	176-062-9-001	R172	BRSJ202794Z	011-002-5-279
TR008	BDBC1674111	176-081-9-002	VR002,004	BRTY0182104	008-465-9-003
TR001,002,006,007, 010,011,023,024,025	BDBC1675111	176-065-9-001	VR001,003	BRTY0182204	008-465-9-005
TR028	BDBC2086104	176-108-9-002	VR005	BRTY0182504	008-843-9-001
TR501	BDBC2166103	176-108-9-001	VR505	BRVY0612001	008-843-9-002
TR021,039	BDBC3242536	176-191-9-001	VR504	BRVY0613001	008-843-9-003
TR009	BDCB0192533	176-191-9-001	VR503	BRVY0614001	008-843-9-004
IC004	BDEY0109002	307-328-9-001	VR502	BRVY0615001	008-843-9-005
IC001	BDEY0471001	307-415-9-001	VR501	BRVY0616001	008-843-9-006
IC006	BDEY0483001	307-415-9-002	SP501	BSPY0053001	580-073-9-001
IC003	BDEY0742001	307-415-9-003	S504	BSRY0353001	083-312-9-001
IC002	BDEY0743001	307-415-9-004	S503	BSWY0535001	088-147-9-001
IC005	BDEY0744001	307-415-9-005	S351,352	BSWY0539001	084-155-9-001
FT002	BFLY0009001	140-009-9-001	T002	BTFT0083001	042-021-9-001
FT001	BFLY0055001	143-011-9-001	T001	BTFY00177001	061-050-9-001
F951,951	BFSY0014209	191-251-3-002	FC501	BWFY0510807	428-111-9-001
J003,004	BJKY0089001	773-086-9-001	FC502	BWZY0520807	428-111-9-002
J553	BJKY0221007	777-050-9-001	WA951	BWZY0383001	426-107-9-001
J551	BJKT0221010	777-050-9-002		GCMF217690Z	380-538-9-001
J552	BJKY0221016	777-050-9-003		GCMZ317691Z	380-538-9-002
J501	BJKY0230001	777-050-9-004		GCMZ417693Z	380-538-9-003
J502	BJKY0325001	777-050-9-005		GCSZ17700Z	380-538-9-004
J353	BJKY0328007	777-050-9-006		GHDL317692Z	380-538-9-005
J351	BJKY0328010	777-050-9-007		GMSC405736Z	634-204-9-001
J352	BJKY0328016	777-050-9-008		GNBP417694Z	384-075-9-001
J505	BJKY0329001	777-050-9-009		GNBP417695Z	384-075-9-002
L002	BLAY0029001	066-017-9-001		GNBP417696Z	384-075-9-003
L016	BLAY0088001	066-019-9-002		GNBP417697Z	384-075-9-004
L004	BLAY012001	046-037-9-001		GNBP417698Z	384-075-9-005
L006	BLAY0163001	060-022-9-001		GNBP417699Z	384-075-9-006
L008	BLAY0165001	044-046-9-001		GNBP417701Z	384-075-9-007
L009	BLAY0166001	066-025-9-005		GNBP417702Z	384-075-9-008
L001	BLAY018-1001	060-024-9-002		GNBY417703Z	751-313-9-001
				HBCT416503Z	250-198-9-001
				HCMB317707Z	252-054-9-001
				HCMT317706Z	253-134-9-001
				HMHG402919Z	741-074-9-001
				HSDP317736Z	256-227-9-001
				KDPZ417704Z	600-166-9-002