

INSTALLATION OPERATION AND MAINTENANCE

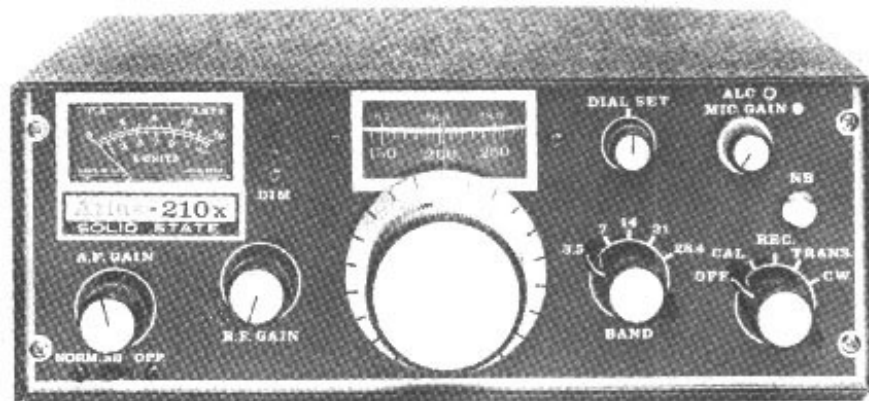

ATLAS-210x/215x

SOLID STATE

SINGLE SIDEBAND TRANSCEIVER

TABLE OF CONTENTS

Section 1 GENERAL INFORMATION	1
1-1 Introduction	1
General Specifications	2
Receiver Specifications	3
Transmitter Specifications	3
Model 220-CS Power Supply Console Specifications	4
Model 200-PS Portable AC Supply	4
Rechargeable Battery pack	5
Section 2 INSTALLATION	6
2-1 Introduction	6
2-2 General Information	6
2-22 Mobile Installations	9
2-28 Fixed Station Installations	13
2-29 Antennas	13
2-33 Fixed Station Antennas	14
Section 3 OPERATION	15
3-1 Introduction	15
3-2 Controls	15
3-3 Power Supply On/Off, Mobile Operation	15
3-4 Power Supply On/Off, 220-CS/200-PS	15
3-5 Function Switch	15
3-6 A. F.Gain	15
3-7 R. F.Gain	15
3-8 Band Selector and Tuning Dial, Model 210X	15
3-9 Band Selector and Tuning Dial, Model 215X	17
3-10 Dial Set	17
3-11 Carrier Balance	17
3-12 S-Meter Zero	17
3-13 Crystal Calibrator	17
3-14 Proper tuning of Single Sideband Signals	17
3-15 Voice Transmission	17
3-16 Modulation Level	18
3-17 ALC.....	18
3-18 CW Transmission	18
3-19 Heat Sink	18
Section 4 CIRCUIT THEORY	20
4-1 Introduction	20
4-2 Receiver Input Circuit	20
4-3 Sensitivity	20
4-4 Selectivity	20
4-5 Oscillator Switching	20
4-6 Transmitter Broadband Circuitry	24
4-7 Receiver Broadband Circuitry	24
4-8 Alignment and Troubleshooting	24
4-9 Voltage Charts	24
4-10 Signal Frequency Ranges and Local Oscillator Frequencies	25
4-11 PC-100C - First Mixer/First I.F. Amplifier	26
4-12 PC-200C — Second I.F. Amplifier, Second Mixer, Mic. Amp. S-Meter Amp.	28
4-13 PC-300D - Receiver Audio, Oscillator Switch	30
4-14 PC-500D/520A - Pre-Amplifier, Driver, Power Amplifier, SWR Protect	32
4-15 PC-400C VFO Board and Tuning Circuits	34
4-16 PC-600 Carrier Oscillator, Buffer Amplifier	36
4-17 PC-800C/1200 Receiver Input Tuning	38
4-18 PC-820 100 kHz Crystal Calibrator	41

	4-19 PC-900C Transmitter Input Tuning	42
	4-20 PC-1010/1020 Low Pass Filters	44
	4-21 PC-1100A SWR Bridge, Antenna Relay	46
Section 5	ACCESSORIES	47
	5-1 Model PC-120 Noise Blanker	47
	5-2 Model 10x Crystal Oscillator	49
	5-4 Model VX-5 VOX	52
	5-5 Model DD-6 Digital Dial	52

LIST OF ILLUSTRATIONS

Figure

1-1	Atlas Model 21 Ox Illustrated with Optional 220-CS AC Console	1
2-1	Remote CW Transmit Switch for Atlas Transceivers	8
2-2	Linear Amplifier connections for Atlas Transceivers	10
2-3	Deluxe Plug-In Mobile Mounting Kit Installation	11
2-4	Mobile Bracket Kit Installation	11
2-5	D.C. Power Connections	12
2-6	Model 220-CS/200-PS Schematic Diagram	14
3-1	Front Panel of ATLAS 210x	16
3-2	Rear Panel of ATLAS 210x/215x	16
4-1	ATLAS 210x/215x Modular Design and Plug-in P.C. Boards . . .	21
4-2	ATLAS 210x/215x Block Diagram	22
4-3	Crystal Ladder Filter Selectivity Characteristics	23
4-4	PC-100C Schematic Diagram	27
4-5	PC-200C Schematic Diagram	29
4-6	PC-300C Schematic Diagram	31
4-7	PC-500D/520A Schematic Diagram	33
4-8A	Model 210x PC-400C Schematic Diagram	35
4-8B	Model 215x PC-400C Schematic (tuning section only)	35
4-9	PC-600 Schematic Diagram	37
4-10A	Model 210x PC-800C/1200 Schematic Diagram	39
4-10B	Model 215x PC-800C/1200 Schematic Diagram	40
4-11	PC-820 Crystal Calibrator Schematic Diagram	41
4-12	PC-9000 Transmitter Input Tuning Schematic Diagram	43
4-13	PC-1010/1020 low Pass Filter Schematic Diagram	45
4-14	PC-1100A SWR Bridge, Antenna Relay Schematic Diagram . . .	46
5-1	PC-120 Noise Blanker Schematic Diagram	48
5-2	Model 10x Crystal Oscillator	49
5-3	Model 10X Crystal Oscillator Schematic Diagram	50
5-4	Model MT-1 Transformer installation	51
5-5	Model DD-6 Digital Dial	52
5-6	Model 210x/215x Chassis Wiring	inside back cover



Figure 1-1. Atlas Model 210x Illustrated with Optional 220-CS AC Console

SECTION 1 GENERAL INFORMATION

1-1. INTRODUCTION

The Atlas 210x Transceiver is designed for single sideband and CW communications in the 10, 15, 20, 40, and 80 meter amateur radio bands. The Atlas 215x covers 15, 20, 40, 80, and 160 meters. They employ all solid state circuitry, with modular construction. The conservative 200 watt power input rating will provide world wide communications from fixed, portable or mobile installations.

Atlas Radio, Inc., is licensed by Southcom International, Inc. of Escondido, California, manufacturers of military and commercial radio equipment. With this agreement. Atlas Radio is able to bring the most advanced state-of-the-art circuit designs to the amateur radio market. Les Earnshaw, founder and Director of R&D at Southcom International, is considered to be one of the foremost solid state engineers in the world, effectively proved by the rapid growth of Southcom International in the military and commercial radio markets of the United States, as well as many other countries.

The high performance and reliability of the Atlas transceiver is enhanced by the finest craftsmanship, and a most thorough quality control program. Our staff is made up of highly skilled assembly workers, technicians, and engineers, many of whom are active radio hams. Our service department, if and when needed, is dedicated to making every Atlas owner a satisfied customer. Speaking for all the gang at Atlas Radio, we wish you many hours of operating pleasure with your Atlas transceiver.

73 Herb Johnson W6QKI President

GENERAL SPECIFICATIONS

BAND COVERAGE:

ATLAS 210x: Covers 80, 40, 20, 15, and 10 meter bands, with internal VFO ranges as follows:

3500-4000kHz
7000-7500kHz
14000-14500 kHz
21000-21500 kHz
28400 - 29400 kHz

NOTE: The 10 meter band on the 210x may be easily owner adjusted to cover any 1000 kHz portion of the band.

ATLAS 215x: Covers 160, 80, 40, 20, and 15 meter bands, with internal VFO ranges as follows:

1800 2100kHz
3500 4000kHz
7000 7500kHz
14000 14500kHz
21000 21500 kHz

FREQUENCY CONTROL:

Highly stable VFO common to both receive and transmit modes.

FREQUENCY READOUT:

Dial scale calibrated in 5 kHz increments on all bands except 10 meters, where increments are 10 kHz. Tuning knob skirt provides 1 kHz increments on all bands except 10 meters, where increments are 2 kHz.

EXTERNAL FREQUENCY CONTROL:

Rear socket provides for plug-in of external VFO or crystal oscillator accessory for separate control of transmit and receive frequencies, or for network and MARS operation.

EXTENDED FREQUENCY RANGE WITH CRYSTAL OSCILLATOR:

When the model 10x external crystal oscillator accessory is used, frequency ranges are as listed in the following charts:

1800 - 3000 kHz (Model 215x only)
3000- 5200kHz
5800 - 10000 kHz

13800 14900kHz
20600 21600 kHz

Note: The Model 10x will not operate on the 28.0 MHz band.

CIRCUIT DESIGN:

All solid state, 4 IC's, 18 transistors, 31 diodes. Single conversion, 5520 kHz I.F.

MODULAR CONSTRUCTION:

Includes plug-in circuit boards for ease of maintenance.

PLUG-IN DESIGN:

Transceiver plugs into the Deluxe Mobile Mounting Bracket, or into the optional 220-CS power supply console, making transfer or removal a simple operation. All connectors are standard: SO-239 antenna jack, 1/4 in. phone jacks for Mic., CW key, external speaker or headphones, and linear amplified control.

POWER SUPPLY REQUIREMENTS

Operates directly from a 12 to 14 volt D.C. source with negative ground (standard automotive system). Current drain is 300 to 500 ma. in receive mode, 16 amps. peak in transmit mode. Atlas model 220-CS power supply console and the model 200-PS portable supply are available for AC operation.

FRONT CONTROLS:

Tuning Dial, Dial Set, Function Switch, Band Switch, A.F. Gain, R.F. Gain, Mic Gain, Sideband Selector, Calibrator On-Off, Dial Light Dimmer, ALC Control.

FINISH:

Black vinyl covered aluminum cabinet and bottom cover, anodized aluminum panel.

WEIGHT:

6 lbs. 14 oz. (3.1 Kg) net, 8 lbs. 6 oz. (3.8 Kg) shipping weight.

DIMENSIONS:

9 1/2 in. (24.1 cm) wide, 3 1/2 in (8.9 cm) high, 9 1/4 in. (24.1 cm) deep overall.

RECEIVER SPECIFICATIONS

CIRCUIT DESIGN: Front end design provides exceptional immunity to overload and cross modulation, matching or out performing the best vacuum tube designs. Signals are converted directly to the 5520 kHz I.F. without preamplification. Converter and product detector are double balanced diode rings. IC's are employed in I.F. and AF stages.

SENSITIVITY: Requires less than 0.4 microvolts for a 10 db signal-plus-noise to noise ratio on 160, 80, 40, and 20 meter bands; 0.4 microvolts on 15 meters; and 0.6 microvolts on 10 meters. **SELECTIVITY:** Crystal Ladder Filter, 8 poles. Bandwidth: 2.7 kHz @ 6 db, 4.3 kHz @60db,9.2kHz@ 120 db!! Ultimate rejection more than 130db!! Shape Factor 1.6.

IMAGE REJECTION: More than 60 db.

INTERNAL SPURIOUS: Less than equivalent 1 microvolt signal. **AGC CHARACTERISTICS:** Audio output constant within 4 db with signal

variation from 5 microvolts to more than 3 volts.

OVERALL GAIN: Requires less than 1 microvolt signal for 0.5 watts audio output. (CW carrier, 1000 Hertz heterodyne).

AUDIO FIDELITY: 300 to 3000 Hertz, plus or minus 3 db. **INTERNAL SPEAKER:** 3 in., 3.2 ohm, .68 oz. magnet. Rear jack permits plug in of external speaker or headphones. Headphones of 500 to 600 ohms are recommended. Headphones of a higher impedance may be used, but will require a higher A.F. Gain setting. Lower impedance headphones will require a lower A.F. Gain setting. When transceiver is plugged into the AC power supply console, internal speaker is disconnected automatically, and front facing speaker on console becomes operative.

METER: Reads "S" units from 1 to 9, plus 10to50db.

CALIBRATOR: Provides 100 kHz check points for accurate dial setting.

TRANSMITTER SPECIFICATIONS

CIRCUIT DESIGN : Broadband design eliminates transmitter tuning. Single conversion from I.F. to output frequency produces minimum spurious and mixing products. 2 section low-pass filters on each band provide harmonic suppression equal to commercial standards. Includes ALC and infinite SWR protection.

FREQUENCY CONTROL: Internal VFO automatically transmits on exactly the same frequency that is being received. Rear socket provides for plug-in of external VFO or crystal oscillator accessory for separate control of transmit and receive frequencies, or for network and MARS operation.

POWER RATING: 200 watts P.E.P. input, and CW input, (with 50 ohm resistive load and 13.6 volt D.C. supply) on 160,80,40,20,and 15 meter bands; 120W on 10 meter band. Power output: 80 minimum P.E.P. and CW on 160, 80, 40, 20, and 15 meter bands; 50 watts minimum on 10 meter band.

RTTY /SSTV POWER RATING:

Approximately 90 watts P.E.P input (dependent directly on ventilation of heat sink).

EMISSION : SSB: Lower sideband on 40, 80, and 160 meters. Upper sideband on 20, 15, and 10 meters with Sideband Selector switch in NORM position. Opposite with switch in OPP position. CW: offset frequency.

UNWANTED SIDEBAND: More than 60 db down at 1000 Hertz AF input.

CARRIER SUPPRESSION: More than 50 db down.

THIRD ORDER DISTORTION:

Approximately 30 db below peak power.

HARMONIC OUTPUT: More than 35 db below peak power.

SUPRIOUS AND IMAGE OUTPUT:

More than 40 db below peak power.

CW KEYING: Manual send-receive.Semi-break-in with CW accessory installed in AC power supply console.

TRANSMIT CONTROL: Press to talk with Mic. button, or manual transmit with Function Switch on front panel. Automatic voice control when VOX accessory is installed in AC power supply console.

MICROPHONE: Dynamic or crystal.

Plug requirement: standard 3/8 in. diam. 3 circuit phone plug.

AUDIO FIDELITY: 300 to 3000 Hertz, plus or minus 3 db.

METER: Reads power amplifier collector current, 0-16 amperes.

LINEAR AMPLIFIER CONTROL:
Rear jack provides for keying of linear, and ALC control from linear.

MODEL 220-CS POWER SUPPLY CONSOLE SPECIFICATIONS

INPUT VOLTAGE: 110 or 220 volts AC, 50-60 Hz.

INPUT POWER: 10 watts average, receive. 250 watts transmit peak.

OUTPUT: Low current line: 13.6 volts regulated, 7 amp. High current line: 13 volts at 16 amps.

SPEAKER: 3x5 in. oval, 1.1 oz. magnet, 3.2 ohm voice coil.

FINISH: Textured Vinyl bonded to aluminum, durable and scratch resistant.

PLUG-IN DESIGN: Transceiver plugs directly into power supply console, automatically makes connections for antenna and front facing speaker. Mic. jack and headphone jack are brought out to front panel.

ACCESSORIES: Space under transceiver permits addition of VOX unit. Space in rear permits addition of semi-break-in CW.

DIMENSIONS: 15-1/2 in. (39.4 cm) wide. 5-5/8 in. (14.3 cm) high. 9-1/2 in. (24.1 cm) deep.

WEIGHT: 17 lbs. (7.7 Kg) less transceiver. 20 lbs. (9.1 Kg) shipping weight.

MODEL 200-PS PORTABLE AC SUPPLY

INPUT VOLTAGE: 110 or 220 volts AC, 50-60 Hertz.

INPUT POWER: 10 watts average, receive. 250 watts transmit peak.

OUTPUT: Low current line: 13.6 volts regulated, 7 amp. High current line: 12.5 volts at 16 amps.

INCLUDES: On-Off switch, Fuses, AC cord, and D.C. Cable with connector for transceiver.

DIMENSION: 5-1/4 in. (13.3 cm) wide, 3-1/2 in. (8.9 cm) high, 6-1/2 in. (16.5 cm) deep.

WEIGHT: 7 lbs. 4 oz. (3.3 Kg) less transceiver. 10 lbs. (4.5 Kg) shipping weight.

RECHARGEABLE BATTERY PACK

Globe Battery Division, Globe-Union Inc., P.O. Box 591, Milwaukee, Wis. 53201, manufactures a "GEL-CELL" rechargeable Battery Pack, Model GC1400 which will operate the Atlas transceivers for a number of hours, with operating time determined by receive-transmit ratio, and modulation level. The battery has an Ampere-Hour rating of 7.5 A.H. It comes in a simulated leather case with shoulder strap, and includes an AC charger.

Your Atlas dealer may handle Globe products. Also, it is anticipated that Atlas Radio may have the GC1400 pack available for Atlas dealers. Otherwise, you may contact Globe directly for reference to a Globe dealer.

SECTION 2 INSTALLATION

2-1. INTRODUCTION This section provides instructions for mobile, portable, or fixed station installations of the

Atlas 210x/215x transceivers.

2.2. GENERAL INFORMATION

2-3. **D.C. POWER.** The Atlas transceiver is designed to operate on a power source of 12-14 volts D.C. Power can be delivered to the transceiver via the Deluxe Mounting Kit (DMK), D.C. Cable (DCC), Cigarette Lighter Cable (CLC), Portable Battery Pack, 220-CS AC Console, or 200-PS Portable AC Supply.

2-4. **AUTOMOTIVE D.C. ELECTRICAL SYSTEMS.** The D.C. electrical systems in automobiles may at times generate high voltage transients (spikes of voltage superimposed on the 12-14 volt D.C. system). These transients may be caused by faulty brushes in the starter motor, alternator or generator, or loose wiring, and can represent a possible hazard to the semiconductors in the transceiver. For this reason, we strongly urge that you read the following notes and follow them carefully.

- (a) Clean the battery terminals and clamps, and tighten the clamps securely.
- (b) Tighten battery cable terminals where they attach to the engine.
- (c) Inspect battery cables and terminals for corrosion or wear. Replace them if they look questionable.
- (d) Check battery condition frequently, especially when it approaches its warranty age limit. Use a protective silicone grease on the terminals to inhibit corrosion.
- (e) Check the alternator and regulator connections for tightness. Check primary ignition wiring, horn wiring, lights, etc.
- (f) Measure the charging voltage from the alternator with the engine running at about twice idling speed. Voltage at the battery terminals should measure 13 volts minimum, 14.5 volts maximum. Consult your auto-electric service shop if correction is required.

2-5. **DELUXE MOUNTING KIT (DMK).** The Deluxe Mobile Mounting Kit is a plug-in unit designed for easy removal of the Atlas transceivers. All D.C. power connections are made to the DMK and all necessary hook-up cables, including the D.C. battery cable with polarity protection, circuit breaker, and hardware, are part of the kit.

2-6. **D.C. CABLE (DCC).** The D.C. Cable (DCC) is designed with built-in polarity protection and overload protection. This cable is available from Atlas dealers and can be used with the Mobile Bracket Kit (MBK) or a portable battery pack.

2-7. **CIGARETTE LIGHTER CABLE (CLC).** The Cigarette Lighter Cable is designed for use in those instances when D.C. power is required, and the transceiver has not been installed in the automobile using the DMK or MBK kits. The cable has a special cigarette lighter plug on one end, and a transceiver power plug on the other. Polarity and overload protection is included with the cable.

2-8. **PORTABLE BATTERY PACK.** The 7.5 ampere hour Portable Battery Pack provides 12 volts D.C. power via portable rechargeable batteries. Connections from the battery pack to the transceiver are made with the battery pack cable. All necessary plugs are provided.

2-9. **220-CS AC CONSOLE.** The 220-CS AC Consoles are available through Atlas dealers, and provide all the D.C. power required for the Atlas transceivers. The 220-CS operates from either 110 volts AC or 220 volts AC, selected by changing fuses. A Microphone jack, Headphone jack, and antenna connector are also provided on the console.

2-10. **200-PS PORTABLE AC SUPPLY.** The model 200-PS AC Supply is designed for portable and utility service where the weight and size of the deluxe AC console is not desired. It's compact size and lightweight make it ideal for the traveler, and yet it will do a completely adequate job in full time duty at the home station. It has a slightly smaller power transformer than the AC console, which reduces D.C. input power about 5 percent, but peak power with voice modulation is the same as with the larger transformer. Also, the 200-PS does not contain a speaker, so the one built into the transceiver is used. The 200-PS operates on either 110 volts AC or 220 volts AC, selected by changing fuses.

It is anticipated that a plastic or simulated leather carrying case will be available from Atlas Radio for the 200-PS supply as well as for the transceiver in the near future.

2-11. **TRANSMISSION LINE IMPEDANCE MATCHING.** Proper impedance match between the coaxial feedline and the antenna system is considerably more important with the broadbanded solid state amplifier than with tube type transmitters, which generally have a Pi-type matching network. The SWR should be as low as it can be in order to permit full power operation. As SWR increases, power output from the Atlas transceiver decreases approximately as indicated in the following table.

TABLE 2-1. SWR VERSUS OUTPUT

SWR	APPROXIMATE OUTPUT	NOTE
1.0	100 watts	High SWR will not damage the Atlas transceiver. You may feel free to operate regardless of the SWR. Only power input and output will suffer. Reflected voltage will not cause damage.
1.1	98 watts	
1.2	95 watts	
1.3	90 watts	
1.5	80 watts	
2.0	50 watts	
3.0	20 watts	

2-12. **AMMETER READINGS.** The ammeter on the Atlas transceiver provides an excellent indicator of impedance match. In CW transmit mode, the Mic. Gain control becomes the Carrier Insertion control. With a close match you will be able to run the ammeter up to 12 amps or more (with supply voltage of 13.6 VDC or 117/230 VAC).

2-13. **INFINITE SWR PROTECTION.** The Atlas transceiver has a built-in reflecto-meter which automatically reduces transmitter drive as SWR increases. This makes the power transistors nearly immune to damage from mismatched loads.

2-14. SWR MEASUREMENTS. A bridge for measuring Standing Wave Ratio (SWR) is very useful and strongly recommended for checking impedance match. Use the following procedures.

- (a) Switch the bridge to "Forward" or "Sensitivity position.
- (b) Set the sensitivity control on the bridge to maximum clockwise position.
- (c) Set Mic. Gain on Atlas transceiver to minimum.
- (d) Set the transceiver Function Switch to CW mode.
- (e) Advance Mic. Gain until meter on bridge reads just full scale. (Mic. Gain is Carrier Insertion control in CW mode).
- (f) Switch bridge to "SWR" or "Reflected" position for the SWR reading.
- (g) Tune the transceiver up and down in frequency until you locate minimum SWR. This will indicate the resonant frequency of the antenna, and also the SWR at that frequency.
- (h) Switch the transceiver back to REC. mode. *See Caution note, next page.*

CAUTION

OPERATE THE TRANSCEIVER IN CW MODE FOR ONLY SHORT PERIODS OF TIME, JUST LONG ENOUGH TO MAKE THE SWR MEASUREMENT. CHECK HEAT SINK TEMPERATURE DURING SWR TESTS, AND IF IT IS GETTING QUITE WARM TO THE TOUCH, LET THE RIG COOL FOR A FEW MINUTES BEFORE CONTINUING.

2-15. MICROPHONE CONNECTIONS. The microphone may be either a dynamic or crystal type. A low impedance Mic. will work, but will require higher setting of the Mic. Gain control, and may require closer speaking. If a dynamic Mic. is selected, it should preferably be the high impedance type. The choice of microphones is important for good speech quality, and deserves careful consideration. Select a high quality Mic. with smooth response from 300 to 3000 Hertz or more. An excellent choice is the Shure 404C hand Mic. The plug required for the Mic. connector is a standard 1/4 inch diameter, 3 conductor type. The tip connection is the keying circuit for press-to-talk, the ring connection is for the shielded Mic. lead, and the sleeve or barrel is the common ground terminal.

2-16. VOICE OPERATED TRANSMISSION (VOX). Most press-to talk microphones are short circuited when the button is not pressed, if the VOX accessory is installed in the AC console, this feature must be disabled. Refer to instructions that come with the Mic. Open the case and locate the switch contacts that short the Mic circuit when the button is not pressed, either disconnect the leads, or bend the contact so they do not make.

2-17. CW KEY. A jack on back of the transceiver is provided for insertion of a standard 1/4 inch diameter 2 conductor phone plug. Connect the CW key to this plug with a 2 conductor cable. The sleeve connection goes to chassis ground. Keying potential is less than 10 volts, positive, and draws less than 5 milliamperes. Any of the electronic keyers presently on the market will operate satisfactorily.

2-18. REMOTE CW TRANSMIT SWITCH FOR ATLAS TRANSCEIVERS.

The Atlas transceivers have a function switch which provides for switching into the CW Transmit mode. However, it requires switching from the RLC. to TRANS., and then to the CW position. This procedure is rather awkward, and the circuit shown below (Figure 2-1) provides a more convenient system.

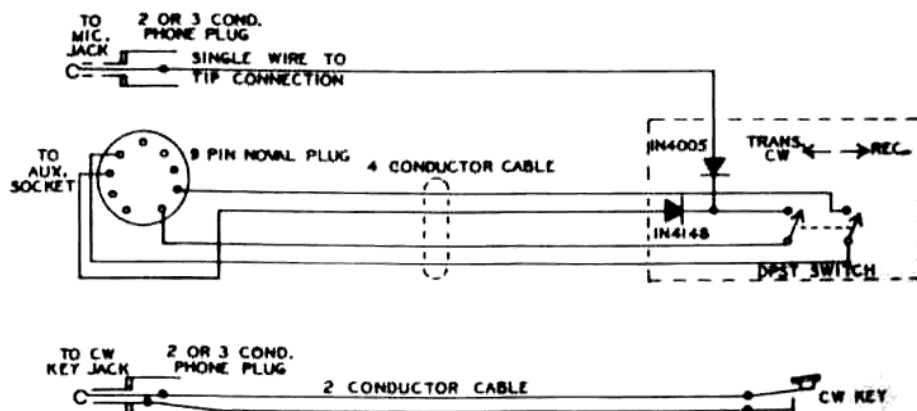

Figure 2-1. Remote CW Transmit Switch for ATLAS Transceivers

The remote switch can be a double pole, single throw toggle switch, and may be installed on a bracket or in a small utility box along with the two diodes. Other parts required are two phone plugs, a 9 pin Noval plug, a 4 conductor cable, and a single insulated conductor.

The remote switch unit may be secured near the CW key, or possibly attached to one side of the key base, permitting quick and easy switching to the CW Transmit mode.

Operation of the circuit is as follows:

When the switch is closed, the single conductor wire coming from the MicJack is grounded through the 1N4005 diode, and the switch to pin 4 or the EXT. OSC. socket. This causes the relays in the transceiver to close, placing the transceiver in transmit mode. At the same time, the lead coming from pin 9 is grounded through the 1N4148 diode, thus disabling the Mic. Amp., and preventing voice modulation of the CW signal.

The other circuit of the 2 pole switch connects the +13 volt line from pin 8 to the +CW lead going to pin 1 of the EXT. OSC. socket. This causes the carrier oscillator frequency (NORM. SB only) to move about 800 cycles up into the filter passband, thus providing automatic off-set frequency during CW transmission.

2-19. EXTERNAL OSCILLATOR SOCKET. This socket is a 9 pin Noval installed on the back of the transceiver, and is for plug in of the Atlas Model 10x Crystal Oscillator accessory, Model 206 External VFO, or the Model DD-6B-C Digital Dials. Jumper wires are factory installed on this socket, and must be removed if any of these accessories are to be used. 2-20. **AUXILIARY SOCKET.** This socket is also a 9 pin Noval, and is for control of a Linear Amplifier or VX-5 or VX-5M CW Semi-breakin.

2-21. LINEAR AMPLIFIER CONNECTIONS. Figure 2-2 illustrates how to connect a linear amplifier to the Atlas transceivers. ALC output from the linear may be connected to Pin 4 on the AUX. socket plug. The ALC control voltage from the linear *MUST* be positive going. Most linears with an ALC output circuit are negative going. If this is the case with your linear, and you wish to utilize ALC control from the linear, it will be necessary that you modify the linear ALC circuit. This will usually consist of reversing one or two diodes in order to generate a positive voltage control instead of negative.

In view of this requirement, you may choose to use the ALC system of the Atlas transceiver alone. Most linears will operate to the full legal power limit with little or no distortion.

2-22. MOBILE INSTALLATIONS

2-23. DELUXE PLUG-IN MOBILE MOUNTING KIT.

This kit includes:

- (a) 6/2 foot D.C. power cable; (b) 25 Amp. Circuit Breaker; (c) Black anodized aluminum plug-in housing; (d) Two 9-inch and two 12-inch cadmium plated steel mounting bars;
- (e) 3 inch wide rear bracket; (f) Package of screws and terminal lugs. Refer to Figure 2-3 for typical transmission hump and under dash mounting arrangements.

1. The rear bracket(s) should be angled as straight back as possible in order to give good support for pushing and pulling the transceiver in and out of the mount.
2. The mounting brackets must be cut and bent to suit the installation, each being unique. Try different positioning and select the one for best ease of operation, and least interference with automobile controls. Then carefully measure each bracket for length and angle of bend on its foot. Bend as required. After bending the brackets, they may be painted with flat black to match the anodized aluminum parts, if desired.
3. Remove the acorn nut and hex nut. Slip bracket over screw, and replace only the acorn nut.
4. Secure brackets to car with No. 14 sheet metal screws. Tighten screws and nuts securely. No. 10 screws are also furnished in case the No. 14 screws are too large.
5. Antenna connection is made by standard coax connector to the coax jack on the rear of the Deluxe Mounting Kit.
6. An external speaker may be connected as follows: Locate the speaker plug on the back of the mobile mount, just above the Mic. plug. Clip out the wire jumper going from the tip lug to the ring lug. This will disconnect the internal speaker. Connect the external speaker from the tip lug to the ground lug. Impedance should be 4 ohms.

7. Black anodizing provides a very durable finish, much better than paint. However, the anodized surface is an electrical insulation. In order to ensure electrical bonding between the transceiver and the car chassis, shakeproof washers must be used under all screw heads. They will cut through the anodizing. Scraping the anodizing off around the junction points on the rear bracket(s) is also recommended. Poor grounding may lead to transmitter instability, which will cause a regenerative or self oscillating condition. If there is any question of adequate grounding, connect a copper braid or strap from the antenna bracket on the mobile mount to the nearest chassis ground, either the bulkhead or transmission hump.
8. The power cable should be run from the mobile mount through the bulkhead into the engine compartment. It should then be connected to the positive and negative terminals as close to the battery as possible. The best way to connect directly to the battery terminal posts is by drilling and tapping for a 10-32 or 10-24 machine screw. The red lead goes to the positive terminal, and the brown to the negative. (Or the white is positive and the black is negative.)
9. The 25 ampere circuit breaker supplied with the kit should be installed in series with the positive lead. It is best to mount it close to the battery end of the cable, at some convenient place on the side of a metal panel or bracket. Sheet metal screws are supplied for this purpose. It is not important that the metal case of the circuit breaker be grounded, since there are no connections made to the case. Cut the positive red power lead, install No. 10 terminal lugs, and secure firmly to the circuit breaker with washers and nuts. Solder the terminal lugs.

NOTICE

The advantage of connecting directly to the battery posts is that loose battery clamps will then not affect the transceiver connections, and the danger of intermittent voltage spikes is reduced. If drilling and tapping the battery posts is not practical, then connect the leads to the engine end of the heavy battery cables. The negative cable will usually be found going to a grounding bolt on the engine block, and the positive cable usually goes to a bolt on the starter solenoid. Use proper terminal lugs at these points for connecting the leads. Battery clamps and terminals should be cleaned and tightened periodically. Anti-corrosion grease is a good recommendation. All other electrical connections under the hood: alternator, regulator, ignition coil, etc., should also be checked and tightened.

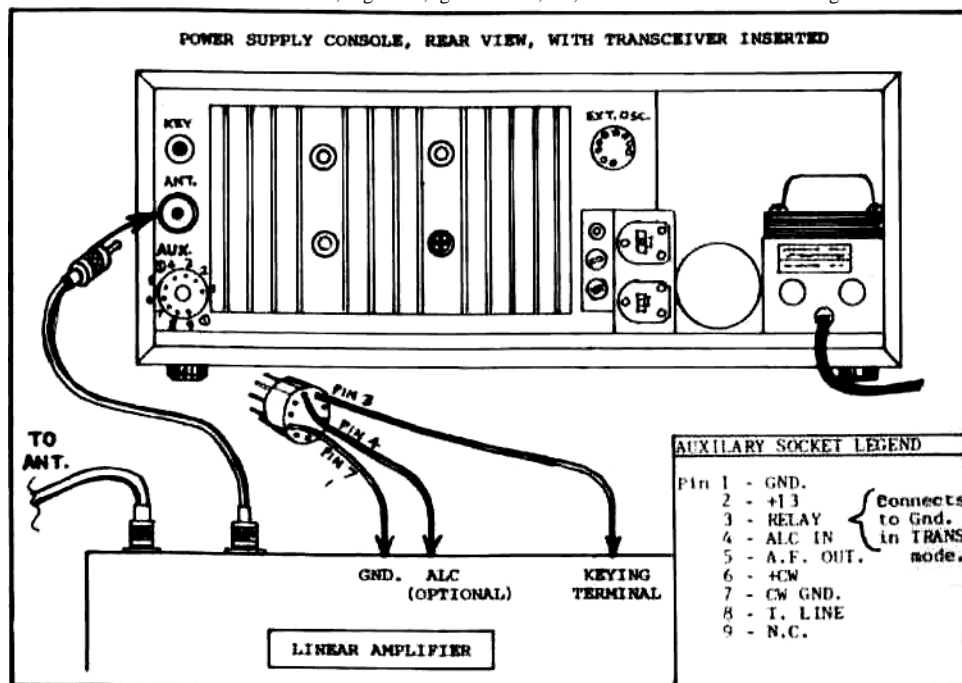

Figure 2-2. Linear Amplifier Connections to ATLAS Transceiver

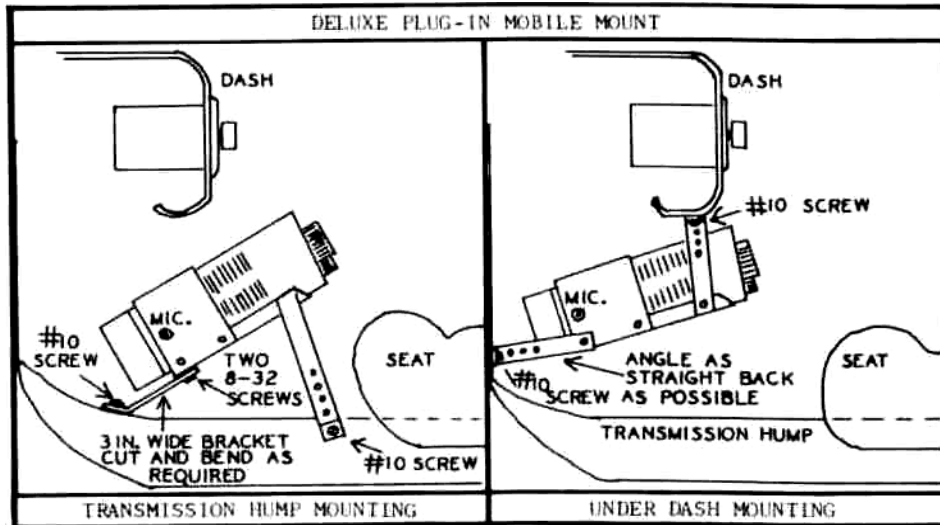

Figure 2-3. Deluxe Plug-in Mobile Mounting Kit Installation

2-24. **MOBILE BRACKET KIT (MBK).** This kit includes: One 9-inch and two 12-inch cadmium plated steel mounting bars with screws. Figure 2-4 illustrates how the transceiver can be hung under the dash, or mounted over the transmission hump. Each installation is different, so this must be left to the individual. Consult your dealer or friends with mobile experience if need be. The brackets can be cut easily and bent as required. The smaller No. 6x3/4 inch screws are for attaching the brackets to the sides or bottom of the transceiver. They will replace the No. 4x1/4 inch screws that came in the transceiver, thus allowing for the 1/8 inch thickness of the bracket. The No. 6 screws will make the brackets more secure than the original No. 4's would. The No. 14 screws are for securing the brackets to the under side of the dash, or to the transmission hump. No. 10 screws are also furnished in case the No. 14 screws are too large.

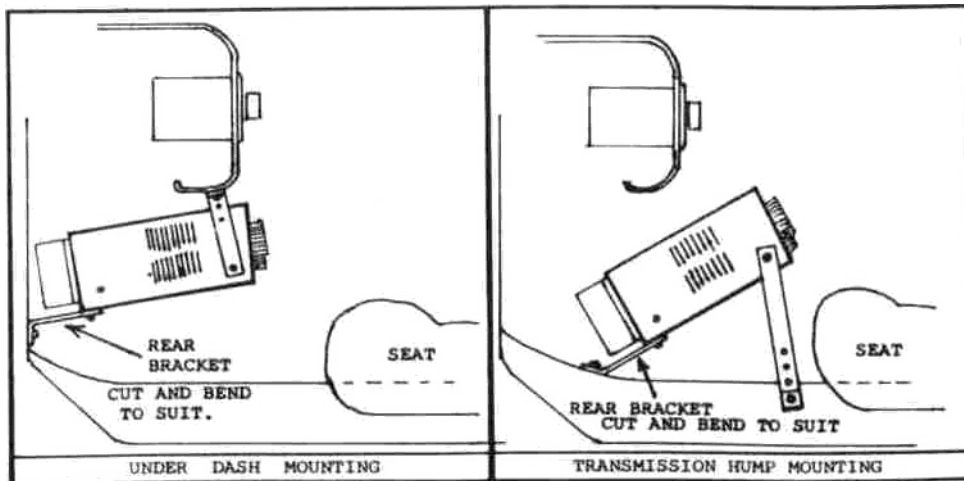

Figure 2-4. Mobile Bracket Kit Installation

2-25. **INSTALLING D.C. POWER CABLE.** The power cable should be run from the transceiver, through the bulkhead, and connected as close to the battery as is practical. The best way is to connect directly to the battery posts. Drill and tap into the lead terminal posts for 10-32 machine screws, and secure No. 10 terminal lugs under these screw heads. The advantage of doing this is that even if the battery clamps work loose, it will not

affect the transceiver connections, and the danger of intermittent transient voltage spikes will be reduced.

If drilling and tapping the battery posts is not practical, then connect the leads to the engine end of the battery cables. The negative cable will usually be found going to a bolt on the engine block, while the positive cable usually goes to a bolt on the starter solenoid. Use proper terminal lugs at these points for connecting the leads. The red lead goes to positive and the brown lead to negative. (If power cable has black and white leads, the black is negative, and the white is positive). A protective diode is built into the transceiver plug, and will open if polarity is inadvertently connected wrong. As discussed in paragraph 2-4, the battery clamps should be cleaned and tightened. All electrical connections should likewise be checked and tightened.

2-26 INSTALLATION OF 25 AMP CIRCUIT BREAKER. The 25 ampere circuit breaker supplied with the kit should be installed in series with the positive lead. It is best to mount it close to the battery end of the cable, at some convenient place on the side of a metal panel or bracket. Short metal screws are supplied for this purpose. It is not important that the metal case of the circuit breaker be grounded, since there are no connections made to the case. Cut the positive red (or white) power lead, install No. 10 terminal lugs, and secure firmly to the circuit breaker with washers and nuts. Solder the terminal lugs.

2-27. OTHER D.C. INSTALLATIONS. In the event that you have not purchased the DMK, MBK, or DCC kits, your transceiver comes with two banana jacks for the positive battery lead, and are to be connected in parallel as shown in Figure 2-5. The banana plug connects to the negative battery lead. The battery leads should be of No. 10 or No. 12 gauge stranded wire of the automotive type. A 20 amp. fuse or circuit breaker should be installed in the positive lead. Figure 2-5 illustrates the proper connections required between the battery and the Atlas transceiver.

CAUTION IT IS EXTREMELY IMPORTANT THAT PROPER POLARITY BE OBSERVED. THE POSITIVE BATTERY LEAD MUST GO TO THE TWO TERMINALS CLEARLY MARKED ON BACK OF THE TRANSCEIVER. THE NEGATIVE BATTERY LEAD MUST GO TO THE TRANSCEIVER CHASSIS GROUND, AND THE BANANA PLUG IS FOR THIS PURPOSE. EVEN MOMENTARY CONNECTION OF THE WRONG POLARITY WILL DESTROY THE TRANSISTORS, AND VOID THE ATLAS WARRANTY.

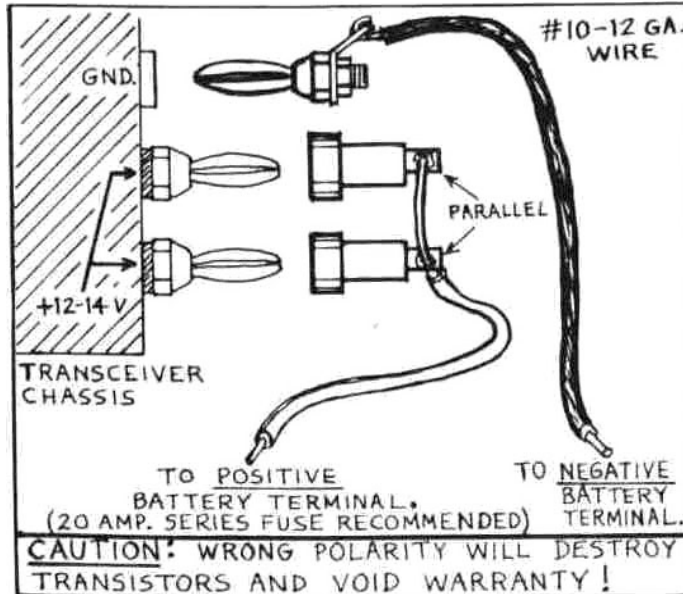

Figure 2-5. D.C. Power Connections

2-28. FIXED STATION INSTALLATIONS

In fixed station installations, the use of the 220-CS eliminates the necessity for making D.C. power connections. The only requirement is that the Atlas Transceiver be firmly seated in the console. When installing the transceiver in the console, always make sure that the unit is pushed all the way into the console. This will insure that all power, Mic, and speaker connections are firmly made.

2-29. ANTENNAS

2-30. MOBILE ANTENNAS. The mobile antenna generally requires more critical adjustment than the home station antenna. This is because it operates over a more narrow bandwidth, and must therefore be adjusted very accurately for resonance. Also, the base impedance is seldom very close to 52 ohms. With the tube type transmitters the Pi matching network will adjust to fairly low impedances, but with a broadband solid state transmitter, such as is used in the Atlas transceivers, a close impedance match is necessary in order to operate at full power. Various claims about impedance are made by manufacturers of mobile antennas, but unfortunately our tests on all the most popular brands indicate that your chances of coming up with a close match are less than 1 to 10. Average base impedance is 18 to 23 ohms. Therefore, some method of transforming the antenna base impedance to 52 ohms is required. (See Section 5-3 for Model MT-1 Broadband Transformer.)

2-31. CAPACITY MATCHING METHOD. This is one method for impedance matching to the mobile antenna which works quite well. A capacitor is connected from the antenna base to ground. This capacitor is part of an L network which transforms the base impedance from a low value up to 52 ohms. The small amount of "L" required is actually "borrowed" from the lower part of the loading coil. The capacity value must be determined experimentally, and will vary from band to band, as well as from installation to installation.

On 75 meters, the capacity will generally need to be in the 1000 to 1500 picofarad range. **On 40 meters,** 300 to 400 picofarads and on 20 meters about 200 picofarads. A variable capacitor can be useful to determine what value is required or a collection of silver mica capacitors, some 100 pf's, 200's, 470's, and a 1000 pf can be paralleled in various combinations until the SWR comes down to a low figure. Once you know how much capacity your antenna needs, it is best to make up the permanent capacitor by paralleling two or more silver micas. This will divide the **R.F.** current and reduce the chances of overheating a single capacitor with too much current. Follow the procedure described in paragraph 2-14 when tuning the antenna.

2-32. NOISE SUPPRESSION. The subject of noise suppressing automotive ignition and alternator noise is beyond the scope of this manual, so it will only be mentioned briefly. Many cars will create very little interference in the IIF bands covered by the Atlas transceiver. Almost all cars now use resistance type ignition wire, and will probably create very little ignition noise. More likely the high pitched whine from the alternator will cause more trouble. Refer to the various amateur radio handbooks available from your dealer for information on noise suppression. It will usually be found in the mobile sections. Estes Engineering Co., 930 Marine Dr., Port Angeles, Wash. 98362, manufactures an excellent line of suppression kits which can help cure the more stubborn cases. It is quite likely that your dealer sells the Estes Engineering line also.

IMPORTANT: Make sure that the transceiver mounting brackets are well grounded to the transmission hump or bulkhead.

2.33. FIXED STATION ANTENNAS

On 10, 15, and 20 meters a doublet and most beam antennas will match quite well across the entire band. On 40 meters a doublet tuned for phone band center will match quite well across the band. On 75 meters the average doublet will have a bandwidth of about 100 kc for SWR of 1.5 or less. To work the entire band with full efficiency will require an antenna tuner. On 160 meters an antenna tuner, or at least some kind of matching system will be essential, since even at resonance it is unlikely that the feed point will be near 52 ohms. In any case, it is always best to optimize the antenna system for the frequency where you do most of your operating.

2.34. ANTENNA TUNER OR. "MATCH BOX." An antenna tuner can be a very useful device to compensate for antenna mismatch. This may be especially true if you happen to have a favorite antenna that has been working just fine with the old tube rig, and now you discover the new solid state rig doesn't like the old antenna. Refer to the antenna handbooks for helpful data, or ask your dealer about antenna tuners now on the market.

Figure 2-6. Model 220-CS/200-PS Schematic

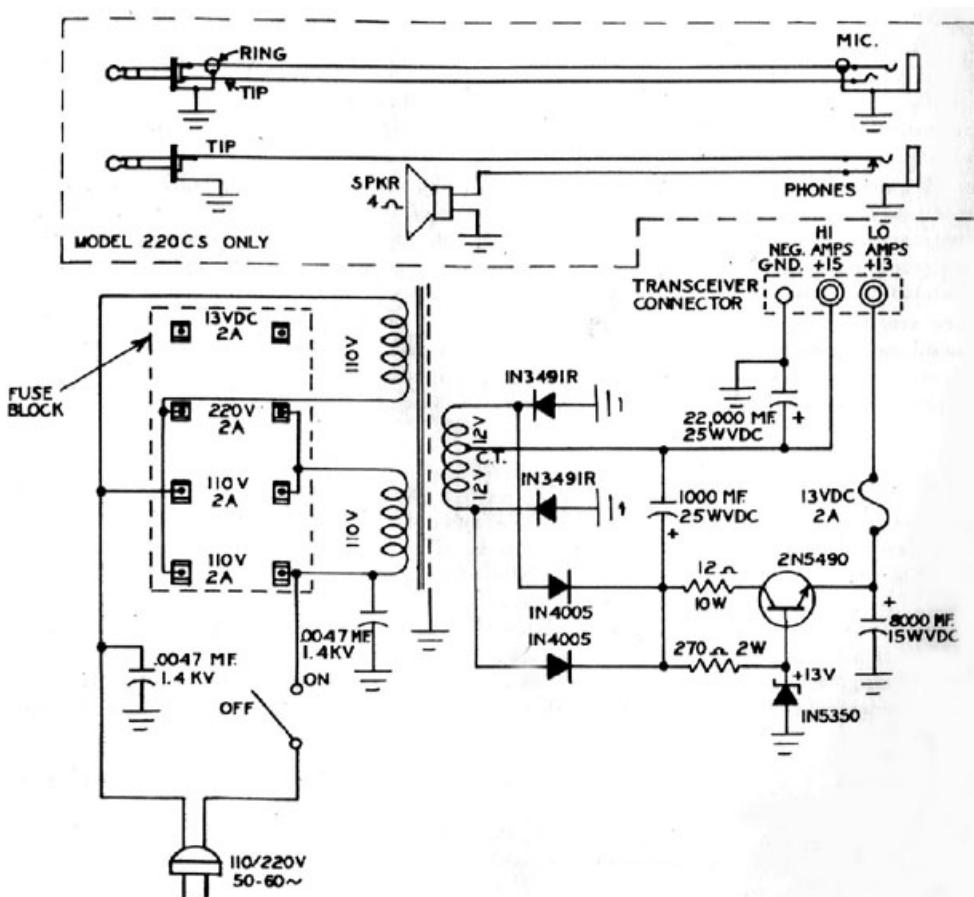

Figure 2-6. Model 220-CS/200-PS Schematic

SECTION 3 OPERATION

3-1. INTRODUCTION

This section provided instructions for operating the ATLAS 210x/215x transceiver and identifies operating controls, indicators, and connections. Front panel controls and indicators are shown and described in Figure 3-1. Rear panel controls and connections are shown and described in Figure 3-2.

3-2. CONTROLS

3-3. POWER SUPPLY ON/OFF, MOBILE OPERATION

The Function Switch has an OFF position which turns off the DC supply to the low current circuits. The high current circuits (Driver and Power Amplifier) remain connected to the DC supply line, but are automatically biased off when the low current line is turned off.

3-4. POWER SUPPLY ON/OFF, 220-CS/200PS.

The 220-CS/200-PS supplies have an ON/OFF toggle switch which turns off the AC supply line. This switch should be used rather than the Function Switch OFF position.

3-5. FUNCTION SWITCH

The first position is the OFF position and is used for mobile operation. The REC. position places the transceiver in receive mode. Press-to-talk and VOX circuits are operative in this position. TRANS position switches the transceiver into transmit mode in the event a Mic. without a press-to-talk switch is used, or if you wish to hold-in transmit mode without having to hold the push-to-talk button down. The CW position is also transmit mode except that the Mic. Gain control now becomes a Carrier Insertion control and carrier frequency has been shifted about 800 Hertz. (See CW Transmission)

3-6. A. F. GAIN The A. F. GAIN control is used to control audio volume in receive mode.

3-7. R. F. GAIN

The purpose of the R.F. Gain control is to permit decreasing the between speech noise level, thus providing more pleasing reception. The AGC system in the ATLAS transceiver has a tremendous dynamic signal range. With full R.F. Gain, sensitivity will automatically return to maximum in the absence of a signal, accompanied by a natural increase in background noise.

You may find it annoying to hear the noise level increase every time the person being received pauses between words or sentences. There are really only two conditions when the R.F. Gain control needs to be on full. One is when you are scanning the band and want to hear weak as well as strong signals. But, a lot of the time you can turn the R.F. Gain down a bit, increase the A.F. Gain correspondingly, and realize more pleasing reception.

3-8. BAND SELECTOR AND TUNING DIAL, MODEL 21 O_x

The numbers on the band selector read in MegaHertz for the respective bands: 3.5 for the 80 meter band, 7.0 for 40 meters, etc.



Figure 3-1. Front Panel of ATLAS 210x



Figure 3-2. Rear Panel of ATLAS 210x/215x

The 0 to 500 dial scale is used on all bands. The 0 to 500 dial scale reads directly on the 7, 14, and 21 MHz bands. On the 3.5 MHz band, the dial scale reading is additive. The 10 meter band is calibrated directly above the dial scale and reads from 28.4 to 29.4 MHz. The increment markings on the tuning knob skirt are 1 kHz apart on the lower bands, and 2 kHz apart on 10 meters.

3-9. BAND SELECTOR AND TUNING DIAL, MODEL 215x

The number on the band selector reads in MegaHertz, the same as on Model 210x, except that it has the 1.8 MHz band instead of the 28.4 MHz.

The 0 to 500 scale reads directly in KiloHertz on the 7, 14, and 21 MHz bands. On the 3.5 MHz bands, the dial scale is additive.

3-10. DIAL SET

This panel control is for adjusting dial calibration to exact reading at a 100 KHz marking

3-11. CARRIER BALANCE

A trim pot is located on the PC-100C plug-in board on the right side of the transceiver. Next to the trim pot is a capacity trimmer which is the phase control. These trimmers should be adjusted for minimum carrier on the lowest frequency band. Connect a dummy load to the transceiver, and measure output voltage in TRANS mode with MIC. GAIN at minimum. It should null down to a level of 0.10 to 0.15 volts RMS. Other bands will give a false reading due to oscillator feedthrough which is not suppressed as much as the carrier.

3-12. S-METERZERO

This is a trim pot located on the PC-200C plug-in board. The PC-200C PC board is located under the dial drum. It can be reached with a phillips screwdriver from the top, just behind the dial light switch. Disconnect the antenna and adjust the trim pot for meter 0.

3-13. CRYSTAL CALIBRATOR. The 100 kHz calibrator should be checked every 6 months or so against a frequency standard such as WWV. Aging will cause it to gradually change frequency, especially during the first few months. The calibrator is mounted on the back side of the aluminum partition, under the shield, behind the dial drum. A capacitor trimmer in the upper left hand corner is for frequency adjustment. A test lead may be run from terminal 1 of PC-100C to the antenna terminal on a general coverage receiver which is tuned to one of the WWV frequencies: 2.5, 5,10 or 15 MHz. Adjust the trimmer for zero beat when WWV interrupts their tone modulation.

3-14. PROPER TUNING OF SINGLE SIDEBAND SIGNALS

Precise tuning of a single sideband signal is very important. Try to tune exactly to the frequency where the voice sounds normal. Avoid the habit of tuning so the voice is pitched higher than normal, and sounds like Donald Duck. This is an unfortunate habit practiced by many operators. If you tune for an unnatural high pitch you will then be off frequency when you transmit. Chances are that the other station will then shift to your frequency while you are talking, and gradually you will move up or down the band. Sooner or later one of you will accuse the other of drifting . . . So, take the extra care to tune for a natural sounding voice, and you will then be enjoying the very best quality in voice communications.

315. VOICE TRANSMISSION

Normal operation is with the Function Switch in the REC. position. Pressing the Mic. button switches the transceiver into transmit mode. Or, if the VOX accessory is installed in the 220-CS console, speaking into the Mic. will switch the rig into transmit mode. A TRANS. position is also provided on the Function Switch for locking in the transmit mode, or in case the Mic. does not have a press-to-talk switch.

3-16. MODULATION LEVEL

Modulation level is adjusted with the Mic. Gain control. When the transceiver is coupled into a proper 52 ohm load, voice peaks will be reaching about 16 amps., although the ammeter cannot respond quickly enough to show these peaks. Adjust Mic. Gain for average readings of 5 to 7 amps. Do not run the gain above this level, or you will flat-top and distort the transmitted audio, as well as cause splatter up and down the band. ALC will help reduce this danger, but it is still possible to over-modulate, so Mic. Gain must be carefully adjusted.

3-17. ALC

The ALC control is located on the front panel of the transceiver, and is concentric with the MIC. GAIN control. It is the inner ring with a black set screw indicating its position. ALC is the abbreviation for "Automatic Level Control," and refers to transmitter modulation level. It aids in preventing over-modulation which causes flat-topping of the power output stages, distortion and splattering outside the channel. Full counterclockwise setting of this control provides no ALC, while full clockwise setting is maximum ALC. Normally, a setting around 12 o'clock will be satisfactory. Some variations between bands may be noted. By having the ALC control on the front panel, you can utilize its advantage most effectively. Too little control will make it easier to over-modulate, while too much control will limit output power. Try various settings and ask for signal reports until you become familiar with its effect. If you have a panoramic scanner, this is, of course, the best way to monitor your output signal.

3-18. CW TRANSMISSION

The Function Switch has a CW position which switches the transceiver into CW transmit mode. A jack on the back is provided for insertion of a standard 1/4 inch diameter 2 conductor phone plug coming from the CW key. Keying is accomplished by bias cutoff of the I.F. Amplifier. The keying circuit operates at less than 10 volts positive to ground, and draws less than 5 milliamps., so any of the electronic keyers will work ok.

In CW transmit mode, the carrier frequency is automatically shifted approximately 800 Hertz. This makes it possible for one transceiver to QSO another transceiver on CW without having to constantly tune the dial back and forth. On 160, 80, and 40 meters the transmit frequency is shifted lower than the receive frequency, while on 20 meters it is shifted higher. *The sideband Selector switch must be in the "NORM" position for CW operation.*

Send-receive changeover must be made with the Function Switch, and it may be a bit inconvenient to pass through the TRANS position every time. The serious CW operator will want to install the semi-break-in accessory kit in the 220-CS console. This item installs in back of the power supply, and includes a sidetone oscillator with volume, pitch, and delay controls. Refer to paragraph 2-18 for alternate switching method.

In CW mode the Mic. Gain control becomes a Carrier Insertion control. With key down, advance this control clockwise until the meter reads 12 amps. This will be 200 watts input power (at nominal supply voltage), and output will be about 90 watts. (On 10 meters the meter will read 8 to 9 amps., or approximately 120 watts input.)

For Novice Class operation, insert 5.5 amps of carrier for 75 watt legal power limit.

For RTTY/SSTV operation, the input should be controlled for a meter reading of 6.5 amps for 90 watts input.

Heat sink temperature is always the limiting factor on power input, and should be monitored from time to time. Refer to paragraph 3-18.

3-19. HEAT SINK

Adequate ventilation for the heat sink is particularly important in CW operation, since average power input is higher than in SSB transmission. Keep a check on heat sink temperature, and if it is running uncomfortably hot to the touch, back down on carrier insertion, or make the transmission shorter.

CAUTION

THE GREATEST DANCER TO THE POWER OUTPUT TRANSISTORS IS OVERHEATING. THE BLACK ANODIZED HEAT SINK IS DESIGNED TO COOL THE TRANSISTORS ADEQUATELY UNDER NORMAL OPERATING CONDITIONS, BUT AS WITH ANY ELECTRONIC OR MECHANICAL DEVICE, IT IS UP TO THE OPERATOR TO MAINTAIN NORMAL CONDITIONS, AND NOT ABUSE THE EQUIPMENT.

THE MAXIMUM SAFE TEMPERATURE OF THE HEAT SINK NEAR THE OUTPUT TRANSISTORS IS ABOUT 150 DEC. F. THIS IS A TEMPERATURE THAT WILL BE TOO HOT FOR YOUR FINGERS TO HOLD, SO A GOOD TEST IS TO PUT YOUR FINGERS ON THE FINS CLOSEST TO THE TRANSISTORS. IF YOU CAN HOLD ON WITHOUT A LOT OF DISCOMFORT, YOU'RE OK.

OVERHEATING MAY BE CAUSED BY: (A) MODULATING TOO HEAVILY, (B) MAKING LENGTHY TRANSMISSIONS WITH SHORT RECEIVING PERIODS, OR (C) RESTRICTION OF AIR CIRCULATION AROUND THE HEAT SINK. IF THE AIR TEMPERATURE IS HIGH, SUCH AS ON A HOT DAY, OR IN A HOT PARKED CAR, COOLING CAPACITY WILL BE REDUCED. A GOOD RULE IS TO CHECK THE HEAT SINK FROM TIME TO TIME, AND MAKE CERTAIN YOU'RE NOT RUNNING TOO HOT. BACK OFF ON MODULATION LEVEL, OR SHORTEN TRANSMISSION TIME. UNDER ABNORMAL CONDITIONS, A SMALL FAN MAY BE DIRECTED AT THE HEAT SINK. THIS IS AN EXCELLENT IDEA IF SSTV OR RTTY TRANSMISSION IS CONTEMPLATED.

SECTION 4 CIRCUIT THEORY

4-1. INTRODUCTION

The Atlas transceiver employs several unique features in its circuit design which lead to exceptional performance. Most of the circuitry is directly descended from similar equipment manufactured for military and commercial markets by Southcom International, Inc., of Escondido, California. Les Earnshaw, ex ZL1AAX is President and Director of R&D of this company. Operating under license from Southcom, Atlas Radio has access to the very latest state-of-the-art circuit designs which have been tested, proved, and type accepted for military and commercial use. Figure 4-1 illustrates the modular design and plug-in P.C. boards of the Atlas transceivers.

4.2. RECEIVER INPUT CIRCUIT.

Referring to the block diagram illustrated in Figure 4-2, notice that there is no preamplification of the signal. After passing through input tuning circuits, the signal is coupled directly into a double balanced diode ring mixer where it is heterodyned to the 5520 kHz I.F. . Thus, the overload and cross modulation problems commonly encountered with an R.F. Amplifier stage are largely eliminated. This has always been somewhat of a problem with vacuum tube R.F. Amplifiers, and a much more serious problem with transistor or F.E.T. Amplifiers. With its advanced front end design the Atlas transceiver will continue receiving signals in the presence of extremely strong adjacent channel stations that would overload, cross modulate, or desensitize other receivers.

4-3. SENSITIVITY

As with most new developments in technology, it may be difficult to accept the fact that a proper receiver can exhibit good sensitivity without a stage, or more, of R.F. amplification prior to frequency conversion. The fact is that the Atlas is at least as sensitive as the best of the tube or solid state receivers having R.F. Amplifiers. This is due largely to the very low noise figure of the double balanced diode ring mixer, followed by a low noise I.F. Amplifier. Sensitivity is rated at 0.3 microvolts for a signal-plus-noise to noise ratio of 10 dB. Typical measurements will read 0.15 to 0.2 microvolts.

4-4. SELECTIVITY

Following the low noise first I.F. Amplifier, the signal passes through the crystal ladder filter, a highly sophisticated package designed especially for the Atlas transceiver by Network Sciences, Inc., of Phoenix, Arizona. Here is where superior selectivity has been tailored to take full advantage of the extremely wide range of signal levels that the front end design is capable of handling. A 6 dB bandwidth of 2700 Hertz was carefully selected to provide audio response from 300 to 3000 Hertz in both receive and transmit modes. While occupying slightly more bandwidth than a 1200 or 2400 Hertz filter, it has been convincingly proven that transmission and reception of the audio frequencies between 2400 and 3000 Hertz provides a substantial improvement in weak signal readability. At the same tune, the improved fidelity of voice communications is readily noticeable, and helps account for the report of "broadcast quality" from the Atlas. The 6 db bandwidth of 2700 Hertz is backed up by a 6 to 60 db bandwidth ratio of only 1.6 (shape factor), and ultimate rejection greater than 130 db. It is this extremely steep skirt selectivity, illustrated in Figure 4-3, which will reject strong adjacent channel signals.

4.5. OSCILLATOR SWITCHING

The unique method of changing from receive to transmit mode by switching the carrier oscillator and VFO is illustrated in the block diagram, Figure 4-2. This new development is responsible for great simplification of the transceiver circuit, leading to fewer components, lower cost, and great reliability.



TUNING DIAL
DRUM

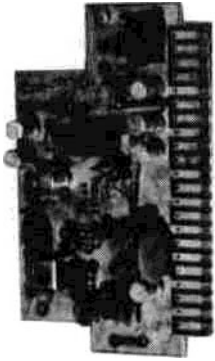

I. F. MODULE
PC-200C

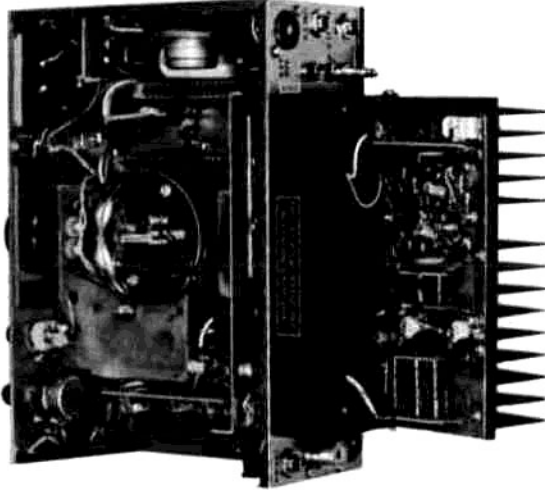

SWIVEL MOUNTED
POWER AMPLIFIER MODULE

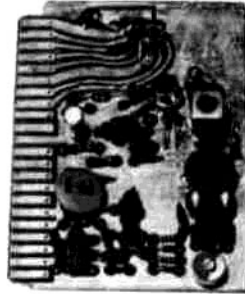

RF MODULE
PC-100C



A. F. MODULE
PC-300C

Figure 4-1. ATLAS 210x/215x Modular Design and Plug-in P.C. Boards

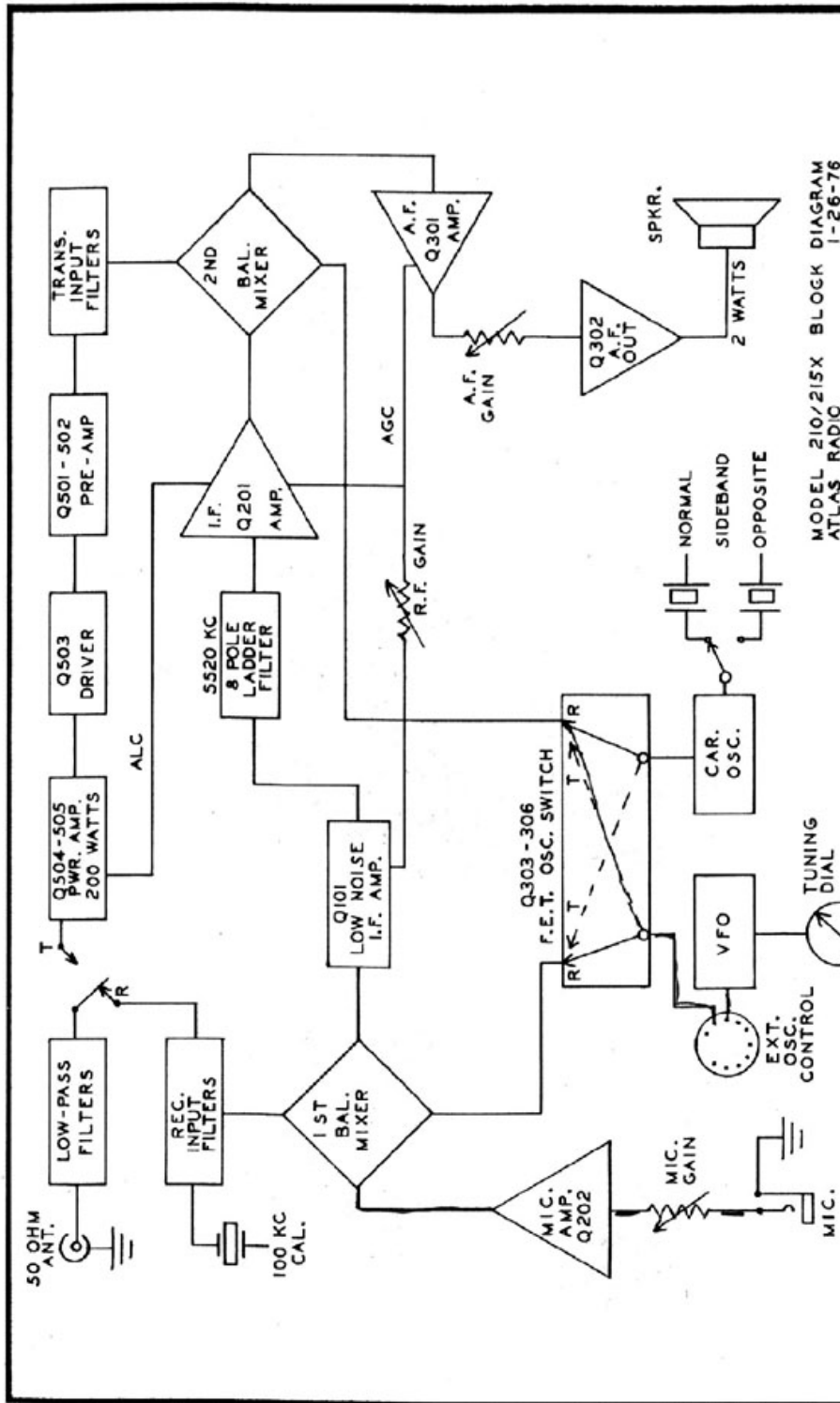

Figure 4-2. ATLAS 210x/215x Block Diagram

ATLAS-210x/215x Se-lect-iv-i-ty!!

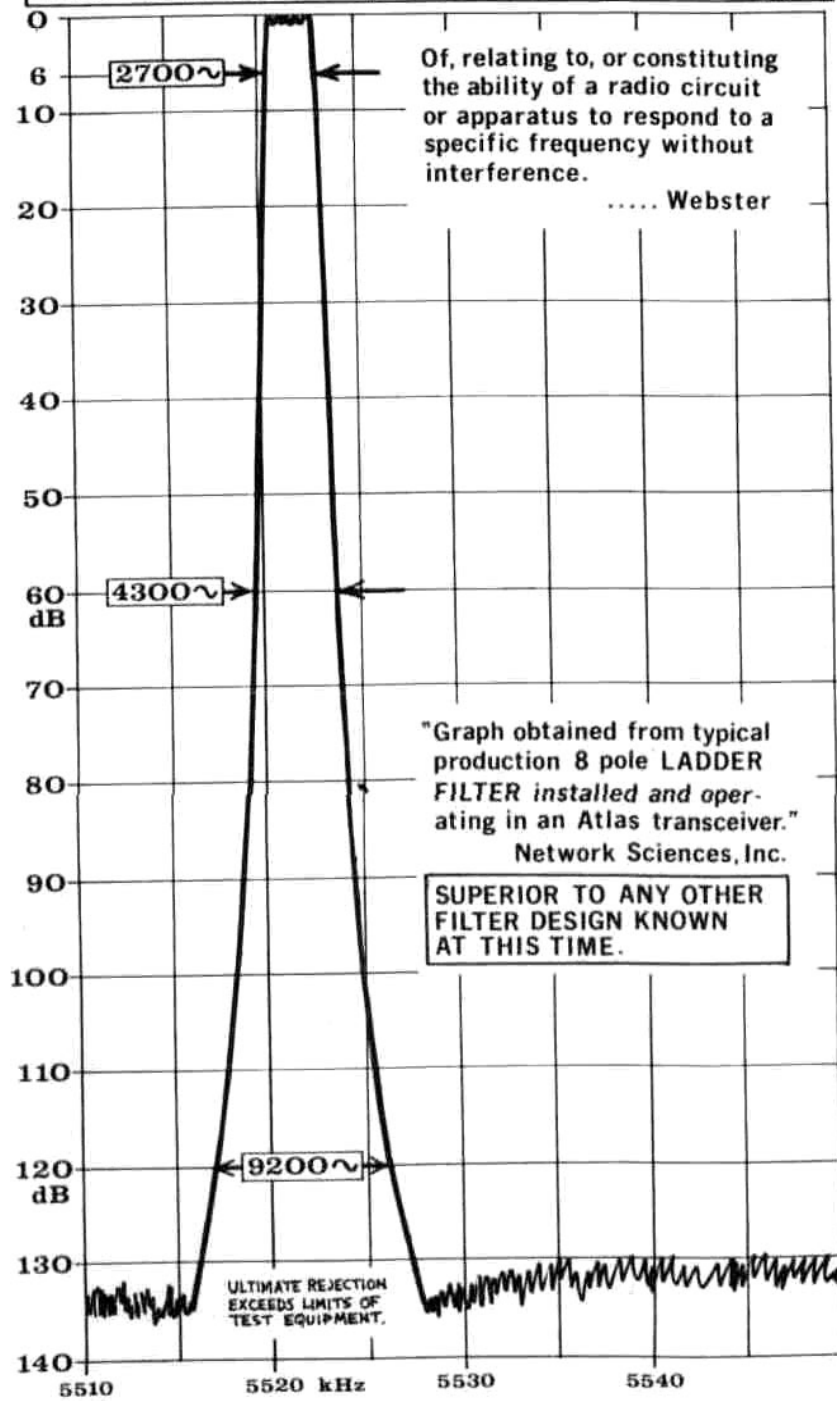

Figure 4-3. Crystal Ladder Filter Selectivity Characteristics

In receive mode the first mixer heterodynes the antenna signal with VFO injection. In transmit mode the first mixer functions as a balanced modulator with carrier oscillator injection and Mic. amp. input. In both modes the first mixer output is at the intermediate frequency (I.F.) of 5520 kHz.

In receive mode the second mixer functions as a product detector with carrier oscillator injection. Its output couples audio frequencies to the receiver audio system. In transmit mode the second mixer heterodynes the I.F. signal with VFO injection. Its output is now at the transmit frequency, and is coupled through tuned circuits to preamplifiers, driver stage, and power output amplifier.

Oscillator switching is accomplished with four F.E.T.'s, resulting in very low intercoupling between oscillators.

4-6. TRANSMITTER BROADBAND CIRCUITRY

The amplifier stages of the transmitter provide full power output over the 1.8 to 21.4 MHz range, about 60% power at 29.7 MHz, and require no tuning. Tuned circuits between the second mixer and transmitter amplifier module select the desired mixer product and reject the unwanted products. These tuned circuits are band switched and provide full coverage of each band. They are double tuned and over coupled, requiring no further adjustment after being factory set.

Harmonic output from the Power Amplifier is suppressed by a band switched two section low pass filter. This filter is connected between the Power Amplifier output and antenna terminal. The low pass filters and Power Amplifier are both designed for a 50 ohm load. It is important that the load be quite close to 50 ohms, non-reactive, in order to operate at full rated power.

4-7. RECEIVER BROADBAND CIRCUITRY

The receiver input filters are band switched, and provide full band coverage without need for a panel peaking control. In addition, the signal passes through the low pass transmitter filter, suppressing possible interference from strong local VHF signals.

4-8. ALIGNMENT AND TROUBLESHOOTING

The overall chassis schematic diagram is Figure 4-15, and is placed at the end of this section to facilitate the technician in matching the P.C. board schematics to the overall schematic. The individual P.C. board schematic diagrams are shown in Figures 4-4 through 4-14. Voltage measurements and parts list are located adjacent to the P.C. board schematics.

4-9. VOLTAGE CHARTS

All voltage measurements must be made with a meter having at least 10 megohms input resistance. All D.C. voltages are designated by the + (positive) symbol. Voltage figures not having the + symbol are RMS values of an AC voltage. Refer to the following notes when making any voltage measurements.

NOTES

1. RMS voltage measured with R.F. **probe, and** bandswitch in 7 MHz position.
2. Approximate RMS voltage with Mic. Jack input of .03 volts at 1000 Hz. Mic. Gain at maximum clockwise.
3. RMS voltage with R.F. probe, **CW mode**, Mic. Gain at Maximum clockwise.
4. Full R.F. Gain, no signal input.

4-10. SIGNAL FREQUENCY RANGES AND LOCAL OSCILLATOR FREQUENCIES

Atlas Radio, Models 210x and 215x:

(a) Normal Frequency ranges with internal VFO	Band. MHz	Operating Range, KHz	VFO Injection Frequency, KHz
	1.8*	1,800- 2,100	7,320- 7,620
	3.5	3,500- 4,000	9,020- 9,520
	7.0	7,000- 7,500	12,520- 13,020
	14	14,000- 14,500	8,480 - 8,980
21	21,000-21,500	15,480- 15,980	
28.4*	28,400 - 29,400	22,880 - 23,880	
*1.8 MHz band, model 215x only. 28.4 MHz band, model 210x only.			

(a) Normal frequency ranges with internal VFO ranges with internal VFO.

Band, MHz	Low Frequency Limit, KHz. .or	High Frequency Limit, KHz
1.8*	1,750	2,150
3.5	3,300	4,150
7	6,900	7,700
14	13,800	14,700
21	20,800	21,700
28.4*	27,800	30,000
• 1.8 MHz band, model 215x only. 28.4 MHz band, model 210x only.		

(b) Extended frequency limits by adjustment of VFO trimmers.

VFO trimmers are reached by removing the transceiver top cover. Adjustment of a trimmer for lower or higher frequency will move the entire band down or up, and will cause the dial Meter to read less accurately. Special frequency ranges with accurate dial calibration are available from Atlas on special order.

Band, MHz	Frequency Range, KHz, with Crystal Oscillator
1.8*	1,700- 3,000
3.5	3,000- 5,200
7	5,800- 10,000
14	13,800- 14,900
21	20,600-21,600
*1.8 MHz band, model 215x only.	

Note: The Model 10x will not operate on the 28.0 MHz band. (c) Extended frequency ranges when using Model 10x external crystal oscillator accessory.

4-11. PC-100C - FIRST MIXER/FIRST I.F. AMPLIFIER

In the receive mode, the R.F. signal is coupled from terminal 1 of PC-100C to the primary of the trifilar toroid transformer LI 01, through capacitors C101 and C110, to the double balanced diode ring mixer, D101 through D104. The VFO oscillator signal is coupled through R105 — C109 to the center tap of the secondary windings of L101, then through C101 and C110 to the First Mixer. The two signals are heterodyned and the difference frequency is the 5520 kHz I.F. signal. The output of the First Mixer is coupled through the trifilar toroid transformer L102, through a tuned circuit consisting of C104 through C107 and LI 03, to the base of the First I.F. Amplifier Q101. The tuned circuit is tuned to the L.F. frequency of 5520 kHz. The signal is amplified by Q101 and then connected through terminal 13 of PC-100C to the crystal ladder filter, which then goes to terminal 3 at PC-200C.

In the transmit mode, the transmit audio input is coupled from terminal 7 of PC-100C through LI 04 to the First Mixer, which now operates as a balanced modulator. The carrier oscillator injection is through terminal 4 of PC-100C and is coupled to the balanced modulator through R105, C109, C110, and C101. The output of the balanced modulator (D101 through D104) is a double sideband, suppressed carrier signal. R101 is used to balance out the carrier, and C103 is used for phase balance. The double sideband signal is at the I.F. frequency of 5520 kHz, and is tuned by the tuned circuit consisting of C104 through C107 and L103. Q101 is the Transmit I.F. Amplifier, and its output is coupled to the Crystal Ladder Filter in the same manner as in the receive mode.

Diode D105 is used to short the receiver input circuit in transmit mode, thus preventing stray transmitter energy from entering the mixer circuit. Diodes D106, 107 and 108 permit R.F. Gain control of Q101 during Receive mode, while maintaining fixed gain in Transmit mode. RL101 switches the +13 volt line for Transmit mode, and also switches the meter circuit from receive to transmit function.

One of the primary advantages of the double balanced diode ring mixer is that both signal and oscillator injection frequencies are essentially balanced out and do not appear in the output circuit. Only the sum and difference frequencies are present at the output. Also, the oscillator is balanced out from the antenna input terminal, eliminating the risk of oscillator radiation.

PC-100C CIRCUIT COMPONENTS

First Mixer, First I.F. Amp

C101,108,109,110,11201 MF 100V Disc	R101 Car. Bal. Trim Pot. 100 Ohms
C102 22pF 10% Disc	R102 10K 10% 1/4Watt
C 103 Car. Phase Bal..10-80 pF Trimmer	R103,110 4.7K 10% 1/4Watt
C104,107001 MF 20% Disc	R104 330 10% 1/4Watt
C105100 pF 10% Disc	R105 47 10% 1/4Watt
C106 91 pF 5% Disc	R106,107 1K 10% 1/4Watt
C111 0.1 MF 50V Disc	R108 180 10% 1/4Watt
C113 15 MF 20V Electrolytic	R109 820 10% 1/4Watt
D101,102,103,		RL101 3p2t 12 vdc Relay
104,107,108 1 N4148 Silicon Diode	L101,102 Trifilar Toroid XFMR
D105,106 BA-182 Silicon Diode	L103 Shielded I.F. Coil
Q101 2N3866 1st I.F. Amp.	L104,105 200 uH RFC

PC-100C VOLTAGE CHART

TERM STRIP NUMBER	REC.	TRANS.
1	(0)	(0)
2	Gnd.	Gnd.
3	Gnd.	Gnd.
4	0.6(11)	1.15(1)
5	Gnd.	Gnd.
6	Gnd.	Gnd.
7	0	0.33 (2)
8	Gnd.	Gnd.
9	N.C.	N.C.

TERM. STRIP NUMBER	REC.	TRANS.
10	+13	+13
11	+13	+13
12	Gnd.	Gnd.
13	+11.8	+10.2
14	+7.3 (4)	+8.5 (4)
15	+3.0	+3.0
16	+3.0	+3.0
17	+13	+12.6
18	+13	+12.6

TERM. STRIP NUMBER	REC.	TRANS.
19	+3	+12.6
20	+13	•
21	+3	+13
22	•	+12.6
Q101 I.F. Amp. Base	+4.0 161	+5.1
Collector	+12.2(16)	+9.4
Emitter	+3.4 (6)	+4.4

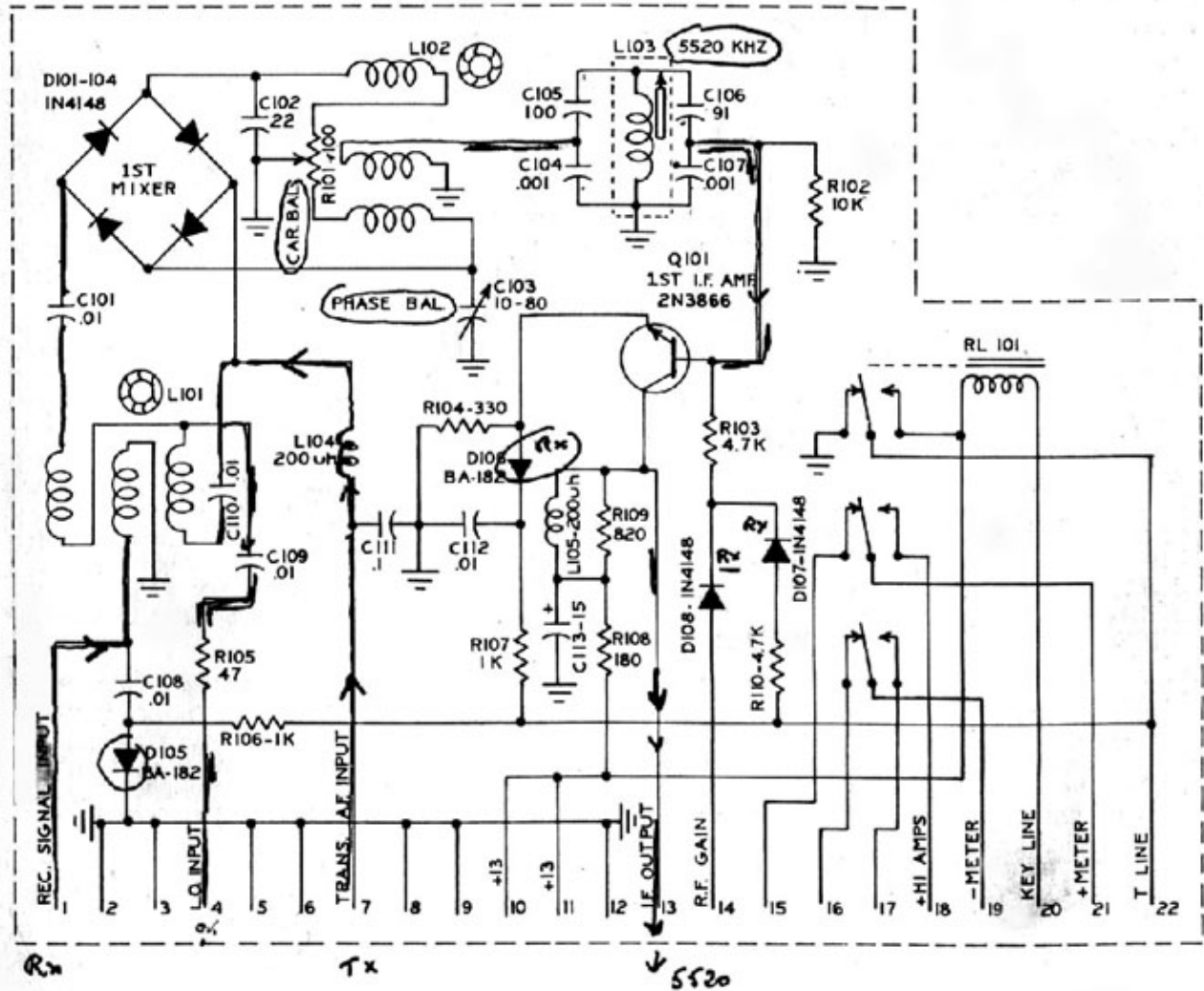

Figure 4-4. PC-100C Schematic Diagram

4-12. PC-200C Second I.F. Amplifier, Second Mixer, Mic. Amp., S-Meter Amp.

In receive mode, the I.F. signal from the 8 pole Crystal Ladder Filter is coupled through terminal 3 of PC-200C to the Integrated Circuit Q201, which is the Second I.F. Amplifier. The signal is amplified and coupled through the tuned circuit that consists of R203, C205 and L201, which is tuned to the I.F. frequency of 5520 kHz; through R204 to the Trifilar Toroid Transformer L202, to the input of the double balanced diode ring Second Mixer Stage consisting of D201 through D204. In the receive mode, this mixer acts as a product detector by heterodyning the carrier oscillator injection and I.F. input to the audio output frequency. The audio output is coupled through C206 and the Trifilar Toroid Transformer L203, through the RF choke L204 to terminal 5 of PC-200C. From terminal 5, the audio signal is coupled direct to terminal 20 of PC-300C.

In transmit mode, the double sideband signal from PC-100C is passed through the Crystal Ladder Filter which removes the unwanted sideband. The resultant single sideband signal is coupled through terminal 3 of PC-200C to the Second Mixer in the same manner as in the receive mode. The VFO injection frequency is through terminal 7 of PC-200C through C208 to the center tap of the Trifilar Toroid Transformer L203. The heterodyning action of the Second Mixer produces the RF transmit frequency which is coupled through the primary winding of L203 to terminal 9 of PC-200C. Q202, which is an integrated Circuit, acts as a 3 stage Mic. Amplifier and also the S-Meter Amplifier.

PC 200C CIRCUIT COMPONENTS Second I.F. Amp., Second Mixer, Mic Amp. S-Meter Amp.

C201,202,203,206,	Q201 MC1350P.I.C.
207,208,211.01 MF 100V Disc	Q202 CA3086I.C.
C204 100 MF 20V Disc	R201 180 10% 1/4 Watt
C205. 130pF5% SM	R202,210. 2.2K 10% 1/4Watt
C209,220. 0.1 MF 50V Disc	R203 3.9K 10% 1/4 Watt
C210. 6.8 MF 35V Electrolytic	R204,205. 47 10% 1/4 Watt
C212,218 2.2 MF 50V Electrolytic	R206,213,221 470 10% 1/4 Watt
C213,215,219001 20% Disc	R207,212. 5.6K 10% 1/4 Watt
C214..... 15 MF 25V Electrolytic	R208 68 10% 1/4 Watt
C216,217. 22 MF 16V Electrolytic	R209,217 1K 10% 1/4Watt
C221.0022 MF 10% Mylar	R211 27K 10% 1/4 Watt
D201,202,203,	R214. 150K 10% 1/4 Watt
204,206,207. 1 N4148 Silicon Diode	R215 100K 10% 1/4 Watt
D205..... 1N4740 10V Zener Diode	R216,219 10K 10% 1/4 Watt
L201 Shielded I.F. XFMR	R218. 39K 10% 1/4 Watt
L202,203 Trifilar Toroid XFMR	R220 100 10% 1/4 Watt
L204..... 200 uH RFC	R222. 1K S-Meter Trim Pot.
L205 0.6 uH I.F. Trap	--

PC-200C VOLTAGE CHART

TERM. STRIP NUMBER	REC.	TRANS.
1	+13	+13
2	Gnd.	Gnd.
3	+3.6	+3.3
4	Gnd.	Gnd. -
5	•	•
6	Gnd.	Gnd.
7	0.55(11)	0.53 (1)
8	Gnd.	Gnd.
9	0	0.27 (3)
10	Gnd.	Gnd.
11	0	0.05 (21)
12	Gnd.	Gnd.
13	•	0.33 (21)
14	•	+6
15	Gnd.	Gnd.

TERM. STRIP NUMBER	REC.	TRANS.
16	9	0.06 (12)
17	0	0
18	Gnd.	Gnd.
19	+3.5	+3.5
20	+2.6	+2.6
21	+10	+10
22	+2.6	+2.6
Q201,I.C.		
I.F.Amp.		
Term. 1-2-8	+10.4	+10.1
3-7	Gnd.	Gnd.
4	+0.39	+0.37
5	+0.45	+0.43
6	+0.38	+0.36

TERM. STRIP NUMBER	REC.	TRANS.
Q202,I.C.		
Mic. Amp.		
Term. 1-5	•	+5.3
2-4-14	•	+4.2
3	•	+3.5
6	•	+2.1
7	e	+1.5
8	0	+5.3
9	+3.4	+3.4
10	+2.7	+2.7
11	+9.8	+9.8
12	e	+0.95
14	•	+0.25

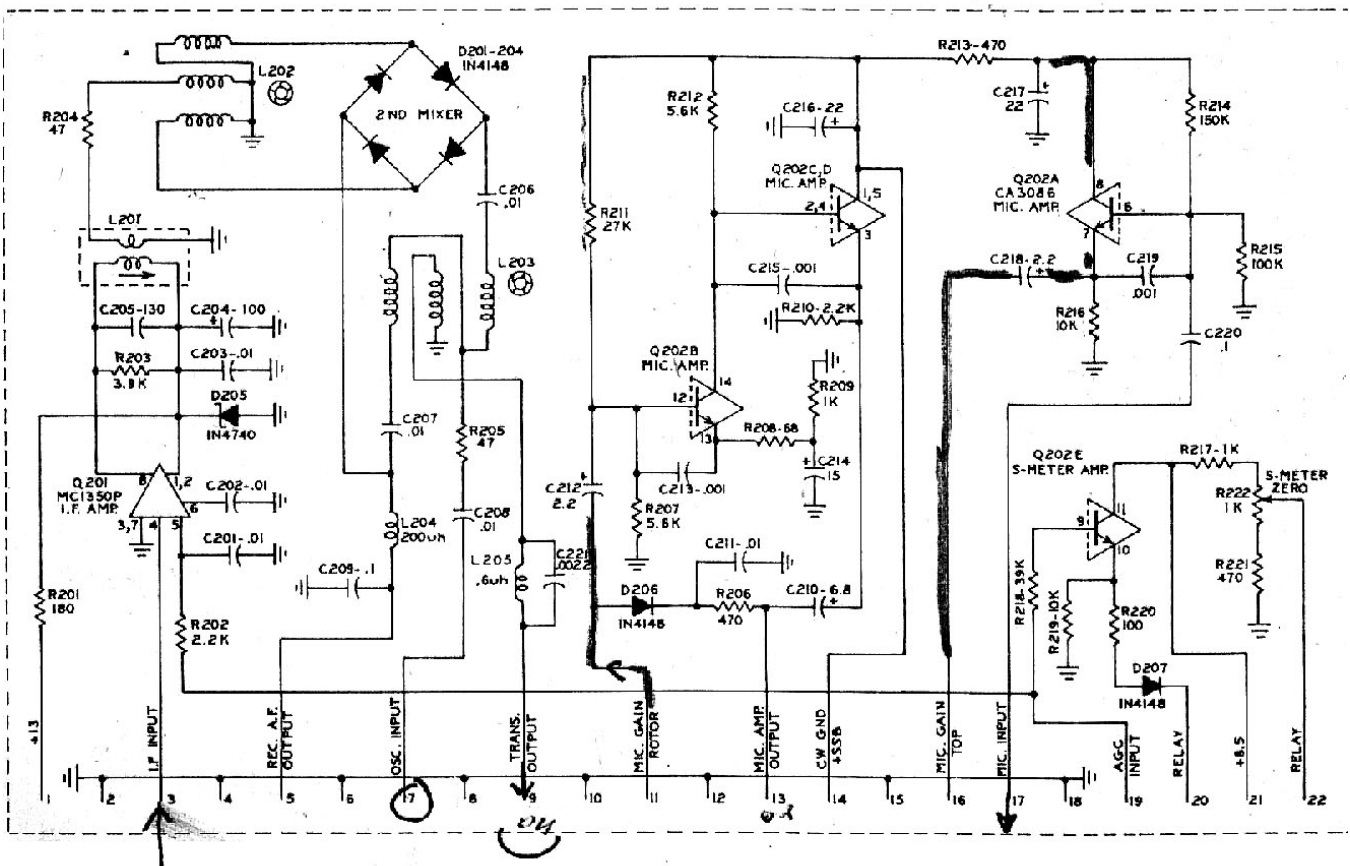

Figure 4-5. PC-200C Schematic Diagram

4-13. PC-300C Receiver Audio, Oscillator Switch

The audio output from PC-200C is coupled through terminal 20 of PC-300C, through C303 to pin 12 of the Integrated Circuit Q301, which is the A.F. Amplifier. The output of Q301 is coupled through C302 to terminal 22 of PC-300C to the AF GAIN control on the front panel, then back through terminal 12 of PC-300C to the input of the AF Power Amplifier Q302. The signal is further amplified and coupled through C320 to terminal 15 of PC-300C to the speaker. Q302 delivers 2 watts of audio to the 3.2 ohm speaker.

The output of Q301 is also coupled through C309 to D301 and D302, the AGC rectifiers. AGC is then coupled through L301 to the input of Q301B which is the AGC Amplifier. The AGC output is fed from pin 7 of Q301B through terminal 17 of PC-300C to terminal 19 of PC-200C where it is coupled through R202 to the Second I.F. Amplifier. AGC attack and decay time are controlled by C310, R312, and R311.

ALC voltage from the SWR bridge is coupled through D303 to Q301B, controlling I.F. gain similar to AGC in receive mode. This same circuit also carries the high SWR, or infinite SWR protection system. High values of reflected voltage from the SWR bridge will reduce I.F. gain, resulting in reduced transmitter drive. SWR figure of 6 or more will practically cutoff the transmitter drive through this circuit.

Q303, 304, 305 and 306 are the F.E.T. Oscillator switches, which connect the VFO and Carrier Oscillator (BFO) to the two mixer stages in proper relationship for receive and transmit functions. The switching is controlled by the "T" line on terminal 1, which is grounded in receive mode and goes +13 in transmit mode.

PC-300C CIRCUIT COMPONENTS Receiver Audio, Oscillator Switch

C301,304,307,308,314,	L301	33uHRFC
323,324,325,326.01 100V Disc	R301,307,313	5.6K 10% 1/4 Watt
C302,317.1 MF 50V Disc	R302	27K 10% 1/4 Watt
C303	R303,310,311,324,	
C305. 47 MF 6.3V Electrolytic	321,327,328	1K 10% 1/4 Watt
C306,319. 15 MF 20V Electrolytic	R305,315,316	470 10% 1/4 Watt
C309,310,321. 2.2 MF 50V Electrolytic	R306,314	100K 10% 1/4 Watt
C311,315. 47 MF 16V Electrolytic	R308	1.5K 10% 1/4 Watt
C312. 6.8 MF 35V Electrolytic	R309,317,318.	2.2K 10% 1/4 Watt
C313	R312	1M 10% 1/4Watt
C318	R319,320,322,323,325,326.	6.8K 10% 1/4 Watt
C320	Q301A	CA3086 A.F. Amp.
C322	Q301B.	CA3086 AGC Amp.
C327	Q302.	LM380N A.F. Output
0301,302,303, 0303,304,		
304,305,306	305,306 . 2N3819 FET Oscillator Switch	
D307,308		BA-182 Silicon Diode

PC-300C VOLTAGE CHART

TERM. STRIP NUMBER	REC.	TRANS.
1	Gnd.	+13
2	+13	+13
3	Gnd.	Gnd.
4	.058(11)	1.18(11)
5	Gnd.	Gnd.
6	.058(11)	1.22(1)
7	Gnd.	Gnd.
8	.55(1)	.053(1))
9	Gnd.	Gnd
10	.58111	.055(1)
11	Gnd.	Gnd.
12	0	0
13	+13	0
14	Gnd.	Gnd.
15	2VAC Max.	0
16	Gnd.	Gnd.
17	+4.2	+4.2
18	0	Varies.ALC
19	+10	+10
20	0	0
21	Gnd.	Gnd
22	0	0

TERM. STRIP NUMBER	REC.	TRANS.
Q301. I.C. A.F. Amp. Term. 1-5	+6.7	—
2-4	+2.2	—
3	+1.5	—
6	+4.2	—
7	+3.5	—
8	+9.8	—
12	+1.9	—
13	+1.2	—
14	+12	—
Q302. I.C. A.F. Amp. Term. 1	+7	+0.6
2-3-4-5-7 9-10-11-	All Grounded	
12-13		
6	0	
8	+5.2	+1.8
14	+13	+13

TERM. STRIP NUMBER	REC.	TRANS.
Q303		
Gate	+0.7	+9
Source	+8.8	+8
Drain	+8.8	+8
Q304		
Gale	+9.8	•
Source	+8.8	+8
Drain	+8.8	+8
Q305		
Gate	+94	•
Source	+8.8	+8
Drain	+8.8	+8
Q306		
Gate	+0.7	+9
Source	+8.8	+8
Drain	+8.8	+8

(1)

NOTE: RMS voltage measured with R.F. probe, and bandswitch in 7 MHz position.

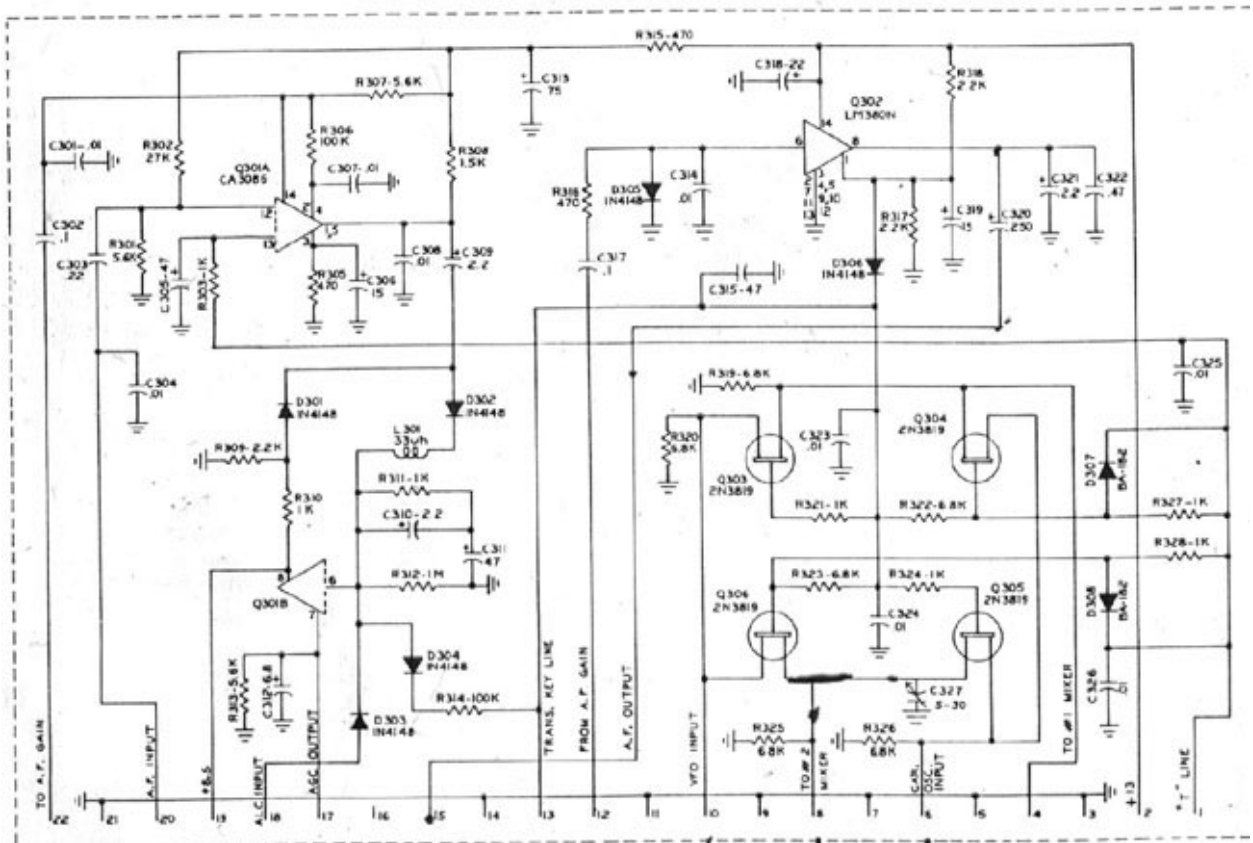

Figure 4-6. PC-300C Schematic Diagram

4-14. PC-500D/520A Pre-Amplifier, Driver, Power Amplifier, SWR Protect

The **R.F.** output from PC-200C is coupled through the Transmitter Input Tuning circuit (PC-900) to the input connection on PC-520A. From the input connection, the signal is coupled through C504 to the base of the Pre-Amplifier Q501, where it is amplified and coupled through C501 to the base of Q502 for further amplification. From Q502, the signal is coupled through the Toriod interstage transformer T501 to the base of the Driver Q503 on PC-500D. The output of the Driver is coupled through the Ferrite Core Driver Transformer T502 to the base inputs of Q504 and Q505, which are the Power Amplifiers. The outputs to the Power Amplifiers are coupled through the Ferrite Core Output Transformer T503 to the output connection on PC-500D. From this connection, the output signal passes through relay RL1, through the Low Pass Filters PC-100/1020 to the 50 ohm antenna connector.

Q506 is a bias regulator for the output stage. Trim pot R515 is used to adjust resting current collector to approximately 1/2 amp. Diodes D501 and 502 regulate the bias circuit, and are thermally connected to the heat sink in order to sense temperature increase. Thus, bias voltage automatically increases with temperature, preventing thermal runaway of the output transistors.

Reflected voltage which is generated by a mismatch in the antenna system is rectified by D1102 and D1103 on PC-1100A in a doubler circuit, filtered, and then connected to Q507, the SWR protect circuit. There it is used to reduce the gain of the first pre-amplifier, thus reducing drive to the power output amplifier. The trimpot R522 is adjusted so that Standing Wave Ratios greater than 2 to 2.5 will drastically reduce R.F. drive.

PC-500D/520A CIRCUIT COMPONENTS Pre-Amplifier, Driver, Power Amplifier, SWR Protect

C501,502,504,507,510,518,	R503,514. 470 10% 1/4 Watt
519,520,521.01 MF 100V Disc	R504, 513. 180 10% 1/4Watt
C503,509..... 0.1 MF 50V Disc	R505,506. 47 10% % Watt
C505 37-250 pF Trimmer	R507,508..... 1.5K 10% 1/4 Watt
0506,512,517..... 0.1 MF 100V Mylar	R509 270 10% 1/4 Watt
C508,516,522 15MF 100V Electrolytic	R510 470 10% % Watt
C511..... 2.2 MF 50V Electrolytic	R512, 519 1.1 10% 1/4 Watt
C513,514 330pF5% Silver Mica	R515 1K Bias Adjust
C515..... 100 pF 5% Silver Mica T501 Toroid	R516 560 10% % Watt R517 1010% 2 Watt
Interstage Transformer T502. Ferrite Core Driver Transformer	R518, 520 4.7 10% 1/4 Watt
T503 Ferrite Core Output Transformer	R521 220 10% 1/4Watt
L501 33uHRFC	R522 2.5K Trim Pot
L502 1.4uHRFC	R523,R524 1K 10% 1/4 Watt
L503 0.6 uH RFC	Q501 MPS6514Pre-Amp
L504. 3 Ferrite Beads, RFC	Q502 2N3866 Amplifier
L505 1.5 uH RFC and Meter Shunt	Q503..... RCA 40582 Driver
L506 7.6 uH Toroid, RFC	Q504,505 CTCCD2545 Power Amplifier
D501,502,503 SI-05 Regulator Diode	Q506 2N5490 Bias Regulator
R501 2.7K 10% 1/4 Watt	Q507 2N3646
R502 10 10% 1/4 Watt	

PC-500D VOLTAGE CHART

TERM. STRIP NUMBER	REC.	TRANS.
Q501		
Base	0	+3.5
Collector	0	+10.2
Emitter	0	+2.8
Q502		
Base	0	+2.4
Collector	0	+12.6
Emitter	0	+1.5

TERM. STRIP NUMBER	REC.	TRANS.
Q503		
Base	•	+1.3
Collector	+15	+13
Emitter	•	+1
Q604, Q506		
Base	+4	+7
Collector	+16	+13
Emitter	•	•

TERM. STRIP NUMBER	REC.	TRANS.
Q606	•	+1.2
Base	•	+13
Collector	+03	+7
Emitter		

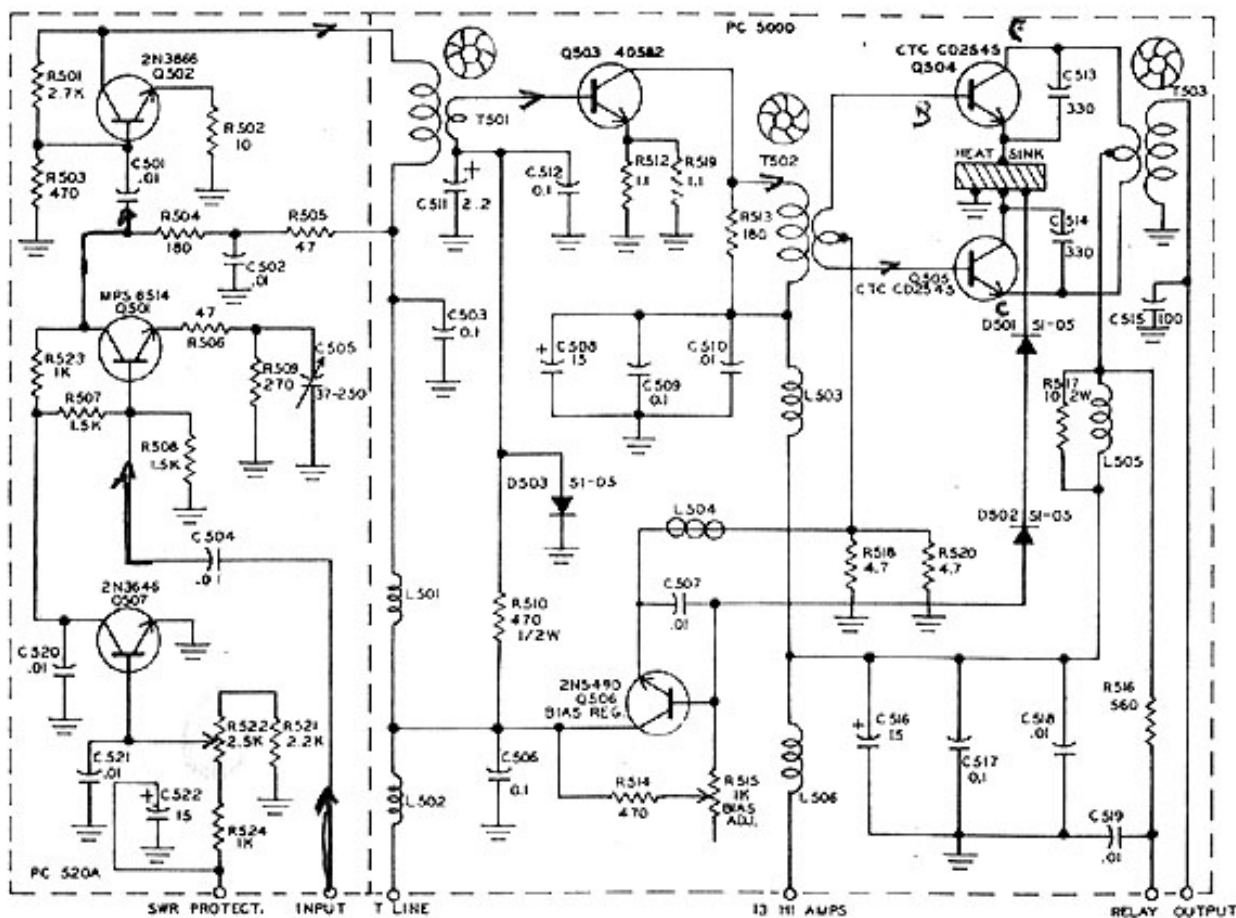

Figure 4-7. PC-500D/PC-520A Schematic Diagram

4-15. PC-400C VFO Circuit Board and Tuning Circuits

PC-400C contains the VFO Oscillator Q401, F.E.T. Buffer 0402, and Output Amplifier 0403. The output of the VFO Oscillator is coupled through C408 to pin 3 of the external oscillator socket, through the jumper to pin 2, then direct to terminal 13 of PC-300C. From terminal 13 of PC-300C, the VFO signal is fed to the F.E.T. Oscillator Switch. Voltage regulation for the VFO circuits is provided by Q1 and D2 on the main chassis.

VFO FREQUENCY CHART, MODEL 210x
I.F. at 5520 kHz

SIGNAL RANGE	INTERNAL VFO RANGE
3500- 4000	9020- 9520
7000- 7500	12520- 13020
14000- 14500	8480- 8980
21000-21500	15480- 15980
28400 - 29400	22880 - 23880

VFO FREQUENCY CHART, MODEL 215x
I.F. at 5520 kHz

SIGNAL RANGE	INTERNAL VFO RANGE
1800- 2100	7320- 7620
3500- 4000	9020- 9520
7000- 7500	12520- 13020
14000- 14500	8480- 8980
21000-21500	15480- 15980

PC-400C CIRCUIT COMPONENTS

C401, 402, 406, R401, 412	27 10% 1/4 Watt
407, 40801 MF 100v Disc R402, 403 10K 10% 1/4 Watt
C403	300pF 5% SM R404, 409470 10% 1/4 Watt
C404	430pF 5% SM R405680 10% 1/4 Watt
C405	100pF 10% Disc R406 15K 10% 1/4 Watt
C409001 MF 20% Disc R407 4.7K 10% 1/4 Watt
C410	15pF 5% Disc R408820 10% 1/4 Watt
L402	1uh RFC R410 2.7K 10% 1/4 Watt
L403	33 uh RFC R411 10 10% 1/4 Watt
Q401	2N706 Osc. Stage R413 100 10% 1/4 Watt
Q402	MPS6514 Buffer	
Q403	2N3866 Output Amp.	
MODEL 21 0x TUNING SECTION	MODEL215x	TUNING SECTION
C411, 416, 419, 422, 423 ..	3-12pF Trimmer	C428, 433,436,440 , 441 .. 3-12pF Trimmer
C412,413,414	10pF 10% Disc	C429
C415,420,421,447	4.7pF 10% Disc	C430, 438, 439 ...
C417	22pF 5% Disc	C431,434,435 ...
C418,424	20pF 5% Disc	C432,437,442,443
C425	27pF 5% Disc	C444
C426	0.8pF Dial Set	C445A
C427A	4pF Main Tuning	C445B
C427B	8pF Main Tuning	C446

PC400C VOLTAGE CHART

TERM. STRIP NUMBER	REC.	TRANS.
0401		
Base	+4	+4
Collector	+4.5	+4.5
Emitter	+3.5	+3.5

TERM. STRIP NUMBER	REC.	TRANS.
Q402		
Base	+5.2	+5.2
Emitter	+6	+6
Collector	+9.2	+9.2

TERM. STRIP NUMBER	REC.	TRANS.
Q403		
Base	+4.3	+4.3
Collector	+6	+6
Emitter	+3.6	+3.6

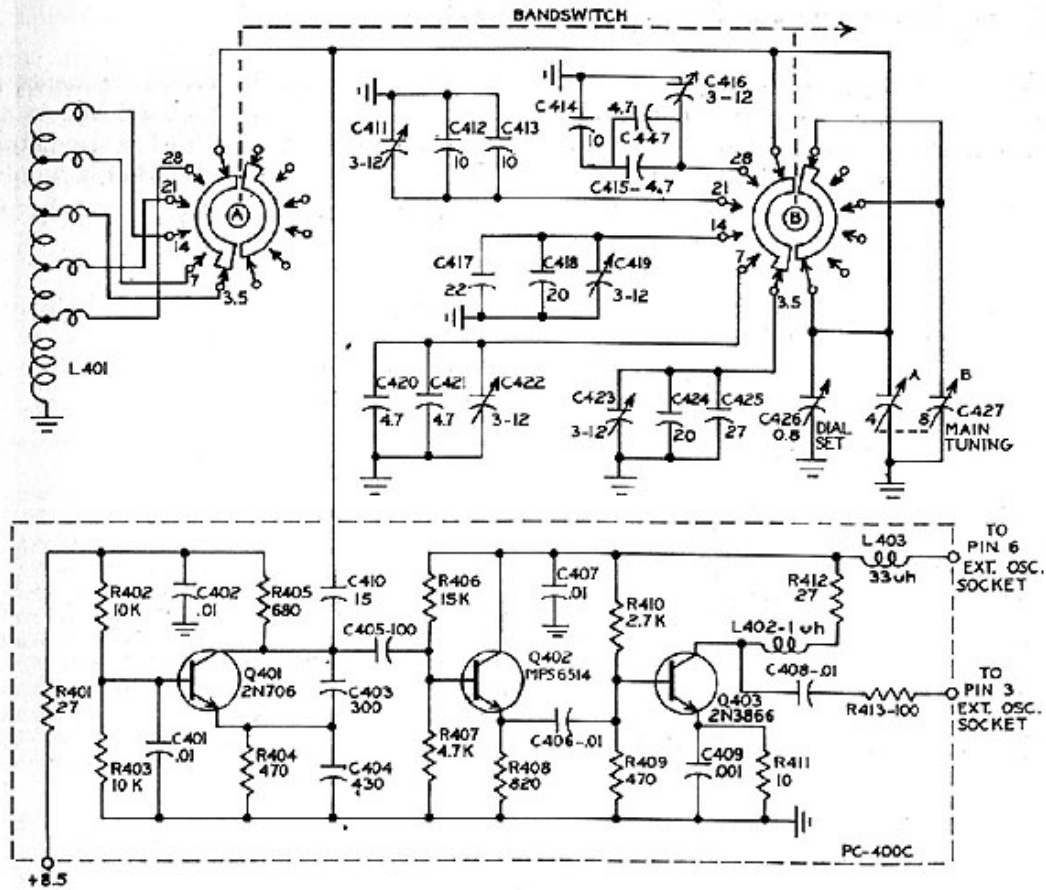

Figure 4-8A. Model 210x/215x PC-400C VFO Schematic and 210x Tuning Section

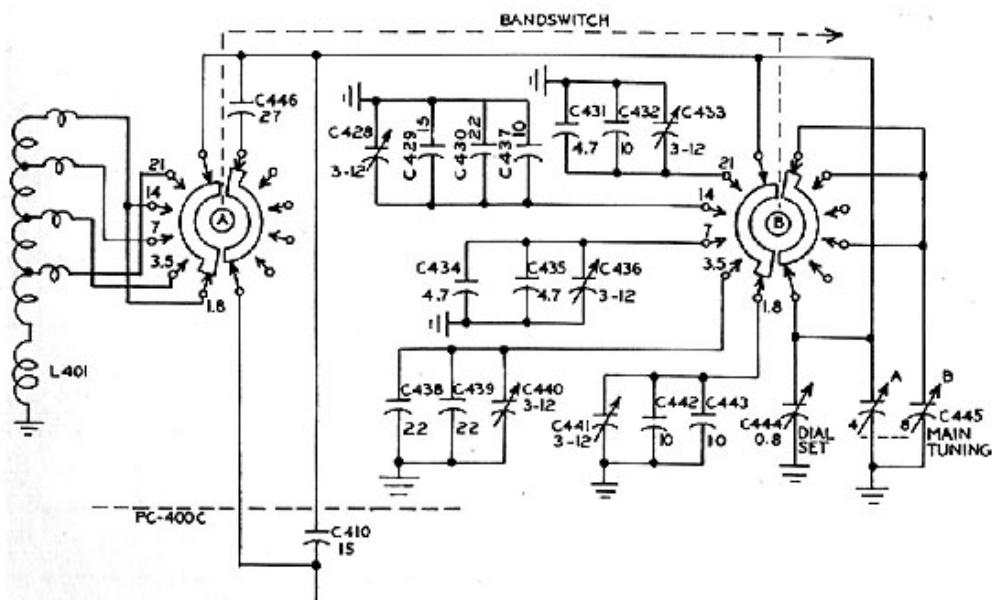

Figure 4-8B. Model 215x VFO Tuning Section Schematic

4-16. PC 600 Carrier Oscillator, Buffer Amplifier

PC-600 consists of those components necessary to generate the normal carrier frequency of 5520 kHz, and the opposite sideband frequency of 5523.3 kHz. Crystal X602 is the Normal sideband crystal, and X601 is the opposite sideband crystal. Q601 is the Carrier Oscillator, and Q602 the Buffer Amplifier. The output of the Buffer Amplifier is coupled through C612 to terminal 6 of PC-300C. From terminal 6, on PC-300C, the carrier frequency is fed direct to the F.E.T. Oscillator Switch.

PC-600 CIRCUIT COMPONENTS Carrier Oscillator Buffer Amplifier

C601	22 pF 10% Disc	R601	4.7K 10% 1/4 Watt
C602,603	5-30 pF Trimmer	R602,604	15K 10% 1/4 Watt
C604	10pF 10% Disc	R603,613	1K 10% 1/4 Watt
C605,606,607,611,61201 MF 100V Disc	R605	220 10% % Watt
C608.....	200 pF 5% Silver Mica	R606	22K 10% 1/4 Watt
C609	100pF5% Silver Mica	R607	10K 10% 1/4 Watt
C610	15 pF 10% Disc	R608,611	82 10% 1/4 Watt
C613	510pF5%Disc	R609,610	33K 10% % Watt
D601	BA-182 Silicon Diode	R612	470 10% % Watt
D602	1N4148 Silicon Diode	L601	1.4 uH inductor
Q601,602	2N706 Transistor	X601	5523.3 Khz OPP. SB Xtal
		X602	5520 Khz Norm. SB Xtal

PC-600 VOLTAGE CHART

TERM. STRIP NUMBER	REC.	TRANS.	CW
Q601			
Base	+2.8	+2.8	+2.8
Collector	+9.3	+9.3	+9.3
Emitter	+3.2	+3.2	+2.5
Q602			
Base	+1.6	+1.6	+1.75
Collector	+1.2	+4.5	+3.7
Emitter	0	0	0

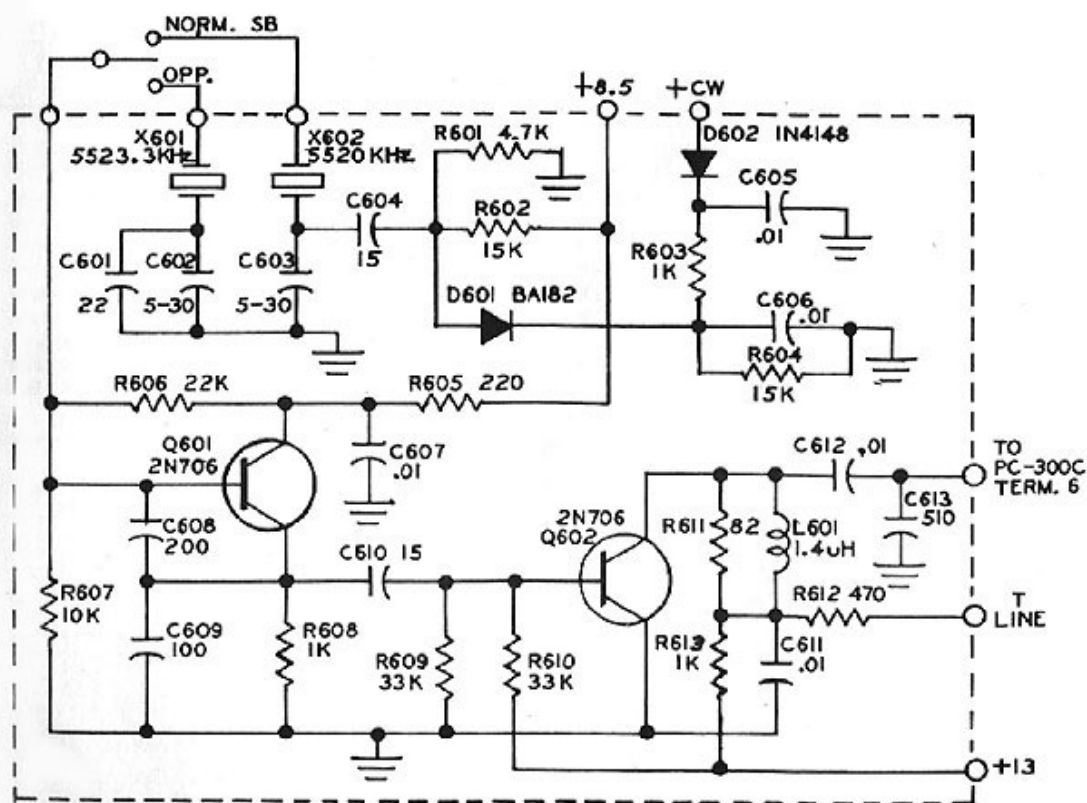

Figure 4-9. PC-600 Carrier Oscillator Schematic

4-17. PC-800C/1200 Receiver Input Tuning

PC-800C contains those components necessary for receiver input tuning. The transformers are bandswitched and provide for full coverage of each band. The transformers have iron cores that are factory adjusted, and should not require further tuning. The coupling capacitors in each transformer are selected to give the amount of overcoupling required for full band coverage, and eliminate the need for a front panel peaking control.

MODEL 210x PC-810C/1200 CIRCUIT COMPONENTS

Receiver Input Tuning

C801 240 pF 10% Disc	L801 7.2 uH Toroid
Q802,803 1800 pF 10% Mylar	L802 803 1.25 uH Toroid
C804 120pF 10% Disc	L804 3.6 uH Toroid
C805,806. 820 pF 10% Disc	L805 80665 uH Toroid
C807 10pF 10% Disc	L807 808 1.4 uH Tuned
Q808,809,810,811. 91 pF5% Disc	L809,810,811,81265 uH Tuned
C812,813. 47 pF 10% Disc	L1201,12026 uH Tuned 5520 Khz
C814. 180 pF5% SM	L12036uHTuned 11.8Mhz
Q1201,12020022 MF 10% Mylar	L1204 11.8Mhz
C1203,1210 470pF5% SM	L1210 17.8 MHz
C1211 200 pF5% SM	

MODEL 215x PC-810C/1200 CIRCUIT COMPONENTS

Receiver Input Tuning

C815 360 pF5% SM	L813 16.5 uH RFC
C816,817 3300 pF 10% Mylar	L814,815. 1.7uHRFC
C818 240 pF 10% Disc	L816 7.2 uH Toroid
C819,820 1800 pF 10% Mylar	L817, 818 1.25 uH Toroid
C821 120 pF 10% Disc	L819 3.6 uH Toroid
C822,823. 820 pF 10% Disc	L820 82162 uH Toroid
C824 10 pF 10% Disc	L822 823 1.4 uH Tuned
C825,826,827,828. 91 pF 5% Disc	L824 82565 uH Tuned
C829 180 pF 5% SM	LI 205,1206,1207..... .6uHTuned 5520 Khz
C 1205,1206,1207.0022 MF 10% Mylar	L12086uHTuned 1 1.8 Mhz
C1208,1209 470pF5% SM	L1209 11.8Mhz

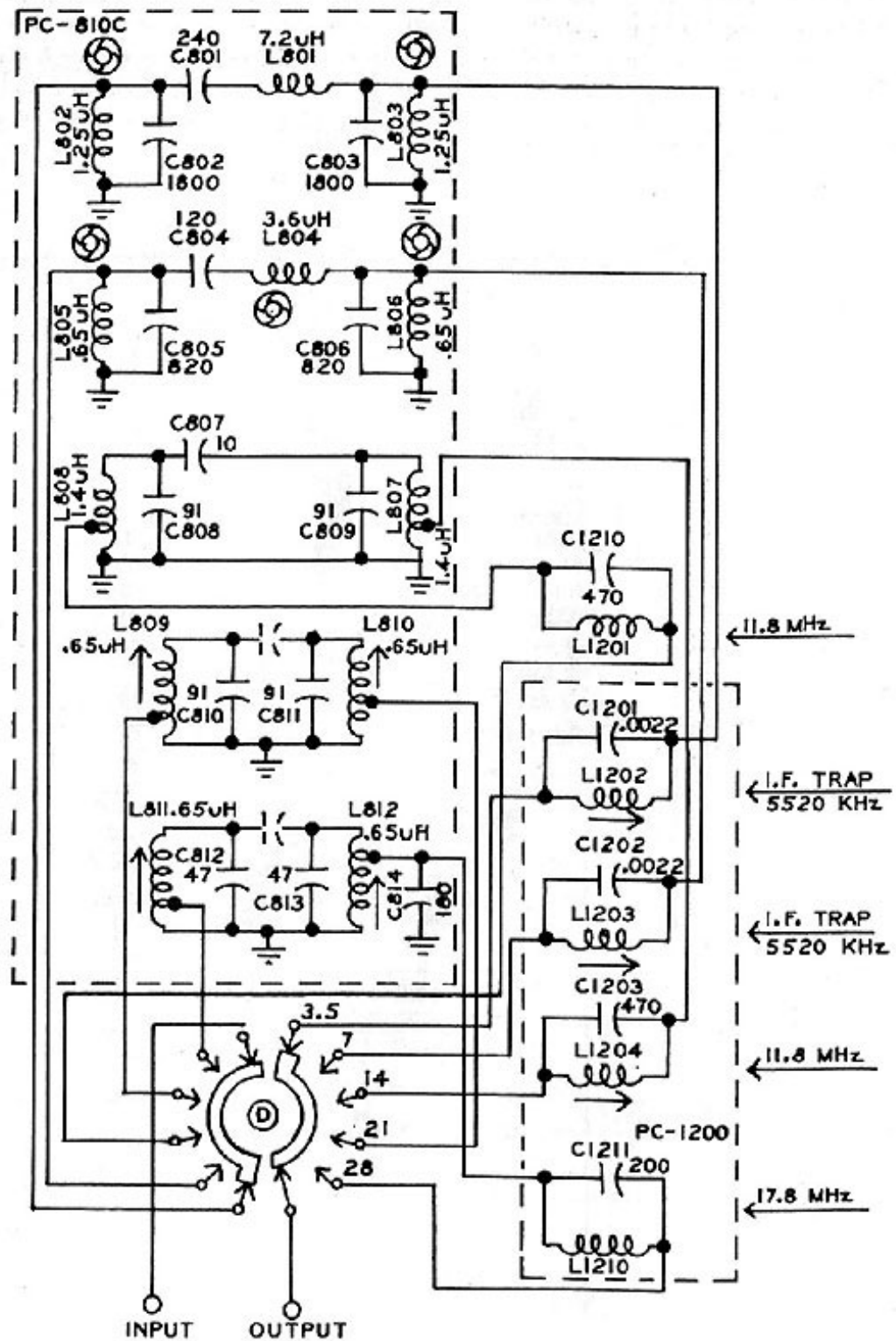

Figure 4-10A. Model 210x
PC-810C/PC-1200
Receiver Input Tuning Schematic

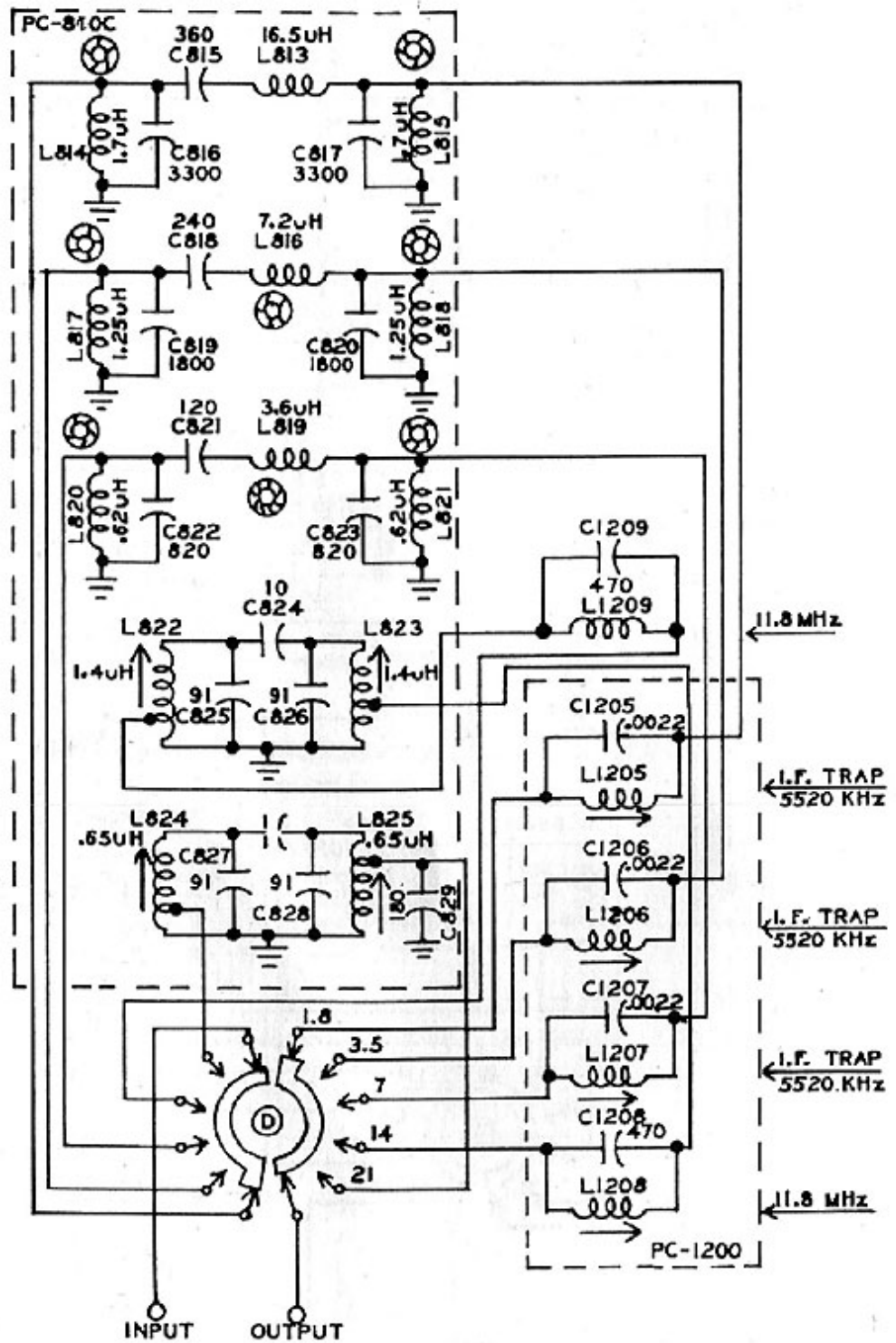

Figure 4-10B. Model 215x
 PC-810C/PC-1200
 Receiver Input Tuning Schematic

4-18. PC-820 100 kHz Crystal Calibrator

The 100 kHz crystal calibrator circuit is assembled on PC-820. Its schematic diagram is shown in Figure 4-11A. It is actuated by the function switch in the "CAL" position. Frequency is adjusted by trimmer C821 against a known standard such as WWV. Harmonics of the 100 kHz calibrator may be coupled out of the transceiver from the antenna connector into another receiver which is tuned to WWV or another known standard. C821 should then be adjusted to zero beat with the standard signal. Output from PC-820 is coupled through C824 to the input terminal of PC-800C, and its harmonics will be received at the 100 kHz increments on each band.

PC-820 VOLTAGE CHART, Function Switch in "CAL." position.

Q821		Q822	
Base	-2.5	Base	-3.4
Collector	+4	Collector	+6
Emitter	0	Emitter	0

PC-820 CIRCUIT COMPONENTS

C821.....	5-30 pF Trimmer
C822.....	300 pF 5% Silver Mica
C823.....	.01 MF 100vDisc
C824.....	2.2 pF 10% Disc
R821.823.	100K 10% 1/4 Watt
R822.824.	10K 10% 1/4 Watt
Q821.822	MPS 3693 Transistor
X821.....	100 Khz Xtal

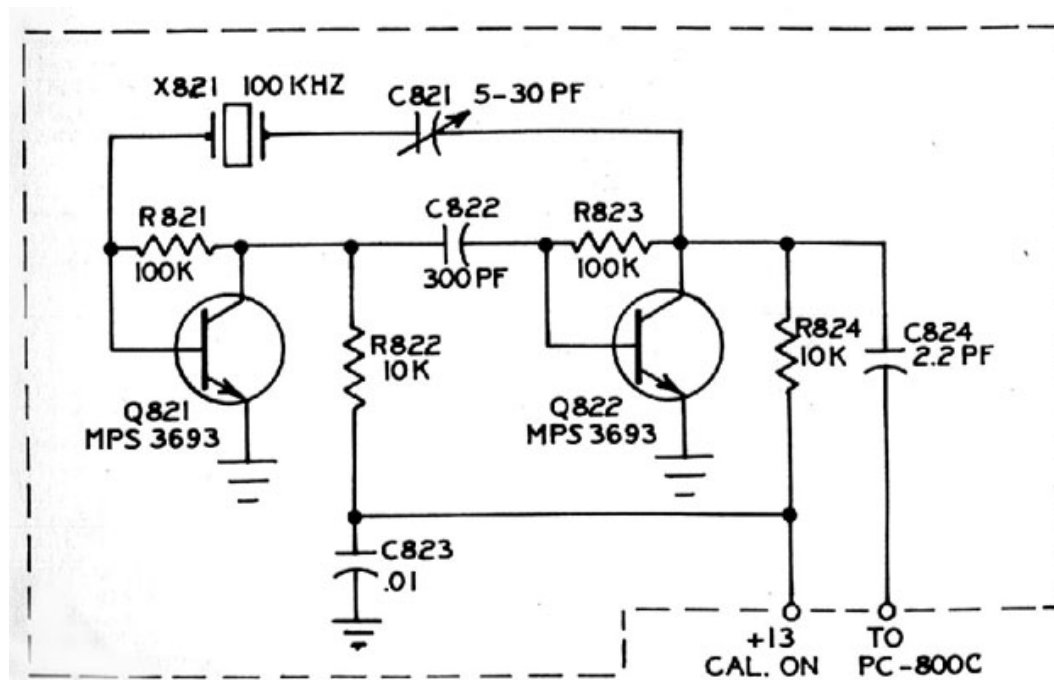

Figure 4-11. PC-820 Crystal Calibrator Schematic

4-19. PC-900C Transmitter Input Tuning

PC-900C contains those components necessary for transmitter input tuning. The transmitter input circuit selects the desired mixer products and rejects the unwanted products. These tuned circuits are band switched and provide full coverage of each band. The tuned circuits are double tuned and over coupled. Trimmer capacitors are located on the board for fine tuning the circuits. These trimmers are factory set and require no further adjustments.

MODEL 210x PC-900C CIRCUIT COMPONENTS Transmitter Input Tuning

C901 240 pF 10% Disc	L901..... 7.2 uHToroid
C902,903 1800 pF 10% Mylar	L902,903 1.25 uH Toroid
C904 120pF 10% Disc	L904..... 3.6 uH Toroid
C905,906. 820 pF 10% Disc	L905,90662 uH Toroid
C907. 2.2 pF 10% Disc	L907,908,909,910. 2 uH Toroid
C908,911. 39pF5% Disc	L911,912. 1 uHToroid
C909,910,913,914,916,917. . 4-40 pF Trimmer	L913,914 0.6uHTuned
C912,915 1 pF.25% Disc	R901,902. 47 10% 1/4Watt
C918,9190022 MF 10% Mylar	R903,904. 6.8K 10% 1/4 Watt

MODEL 215x PC-900C CIRCUIT COMPONENTS Transmitter Input Tuning

C920,923 1500 pF 10% Mylar	L915,916,917. 3 uHToroid
C921,922 2200 pF 10% Mylar	L918 Bifilar Toroid
C924 240 pF 10% Disc	L919. 7.2 uHToroid
C925,926 1800 pF 10% Mylar	L920,921,922. 1.25 uHToroid
C927 120pF 10% Disc	L923,92462 uH Toroid
C928,929. 820 pF 10% Disc	L925,926,927,928. 2 uHToroid
C930. 2.2pF 10% Disc	L929,930 0.6 uH Tuned
C931,934. 39pF5% Disc	L931..... 33 uH RFC
C932,933,936,937. 4-40 pF Trimmer	R905,906,907,908,909 6.8K 10% 1/4Watt
C935. 1 pF .25% Disc	R910 2.2K 10% % Watt
C938,9390022 10% Mylar	
C940 39 pF 5% Disc	

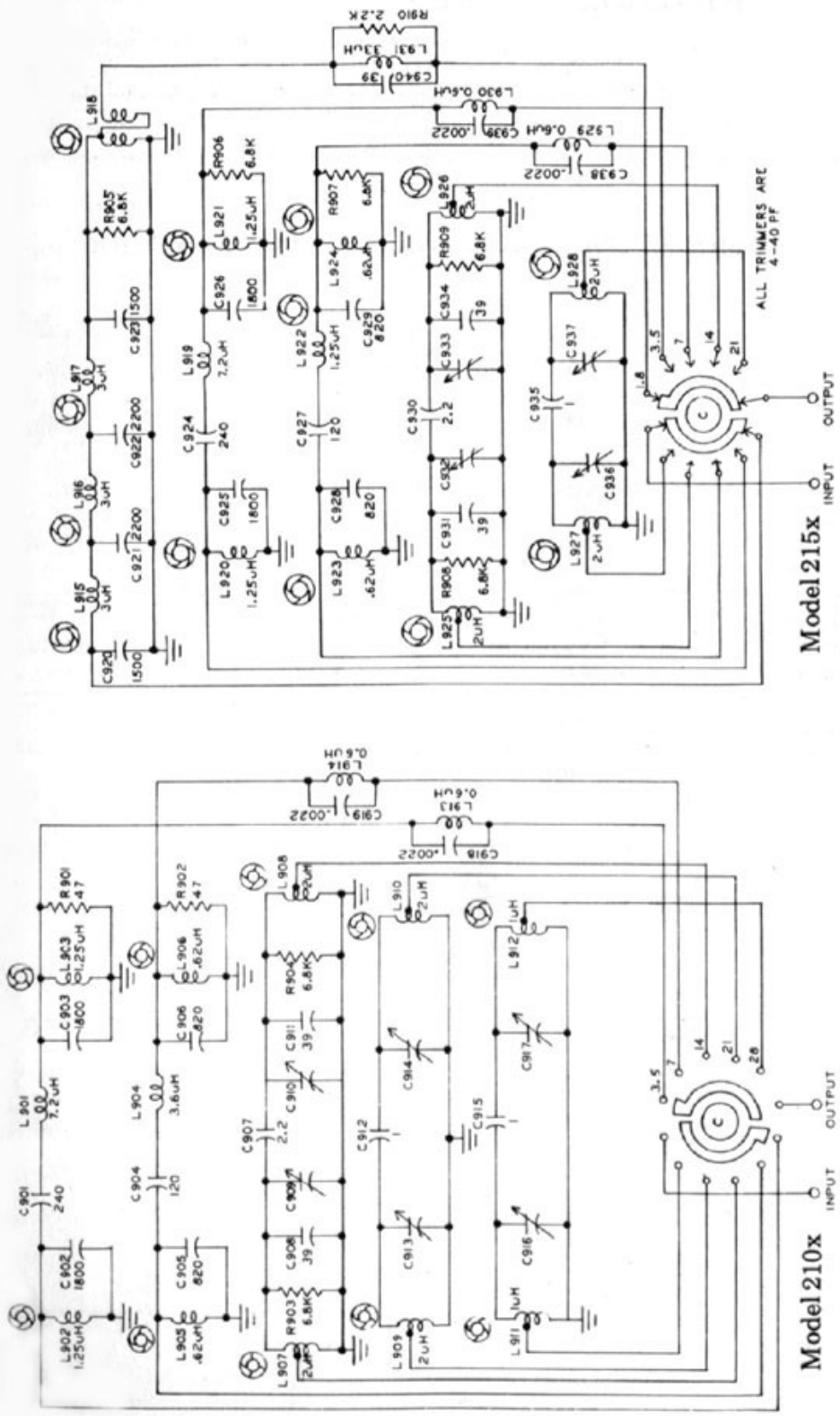

Figure 4-12. PC-900C Transmitter Input Tuning Schematic

4-20. PC-1010/1020 Low Pass Filters

PC-1010/1020 is a band switched two section low pass filter. The filter is connected between the output of the Power Amplifier (PC-500D) and the antenna connector to suppress harmonics 30 dB or more. The filters are designed for a 50 ohm load and it is important that the load be quite close to 50 ohms, non-reactive. The low pass filter is also used during receiving operations to suppress possible interference from strong local VHF signals.

PC-1010/1020 CIRCUIT COMPONENTS AND FREQUENCY CUTOFF (fe)

MODEL210x			MODEL 215x	
Component	Freq. Cutoff	Band Circuit	Component	Freq. Cutoff
C1001 820pF5%SM	FC 1	1	C1016 2200pF 5%SM	FC 1
C1002 1300	5200 Khz		C1017 2200	25 00 Khz
C1003 820			C1018 2200	
L1001-1002 1.8 uH Toroidal			L1011-1012 2.9 uH Toroidal	
C1004 430pF5%SM	FC 2	2	C1019 820pF 5%SM	FC 2
C1005 680	10,000 Khz		C1020 1300	5200 Khz
C1006 430			C1021 820	
L1003-1004 .95 uH Toroidal			L1013-1014 1.8 uH Toroidal	
C1007 180pF 5%SM	FC 3	3	C1022 430pF 5%SM	FC3
C1008 330	20,000 Khz		C1023 680	10,000 Khz
C1009 220			C1024 430	
L1005-1006 .48 uH Toroidal			L1014-1016 .95 uH Toroidal	
C1010 68pF 5%SM	FC 4	4	C1025 180pF 5%SM	FC 4
C1011 270	25,000 Khz		C1026;. 330	20,000 Khz
C1012 180			C1027 220	
L1007-1008 .32 uH Toroidal			L1017-1018 .48 uH Toroidal	
C1013 100pF5%SM	FC 5	5	C1028 100pF5%SM	PC 5
C1014 180	35,000 Khz		C1029 270	25,000 Khz
C1015 100			C1030 180	
L1009-1010 .24 uH Toroidal			L1019-1020 .32 uH Toroidal	

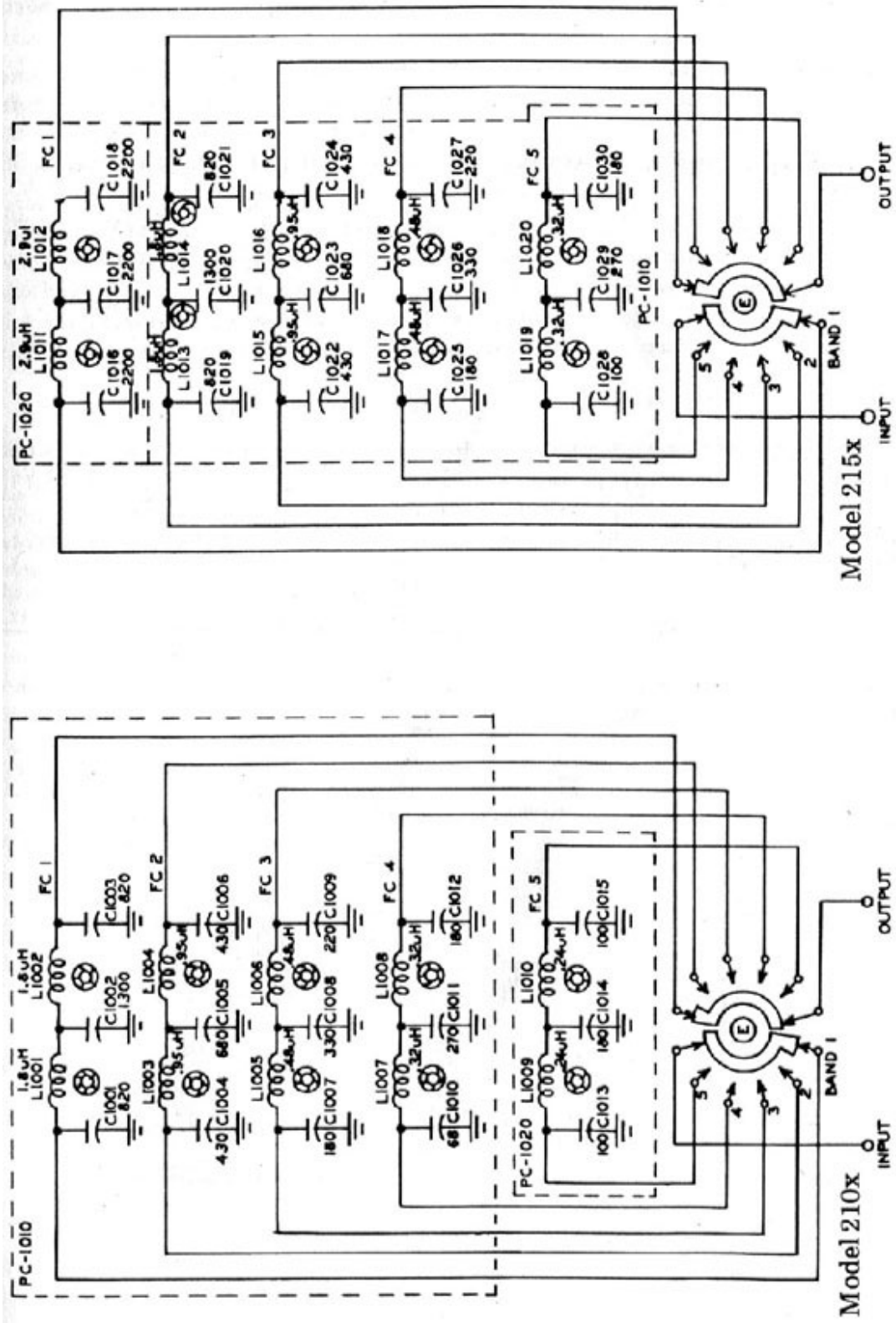

Figure 4-13. PC-1010/1020 Low Pass Filter Schematic

4-21. PC-1100A SWR Bridge, Antenna Relay Circuitry

The relay, RL1101, switches the antenna circuit from the PC-800C receiver input filters over to the PC-500D power amplifier output. The other pole of this relay connects to the AUX. rear socket, and is intended for switching a Linear Amplifier, as described in Section 2-21.

The reflectometer, or SWR circuit, provides a forward going voltage for ALC, (Automatic Level Control), which increases directly as transmitter output increases. This positive voltage connects to the ALC potentiometer on the front panel, concentric with the MIC. GAIN control, and thence to terminal 18 of PC-300C where the ALC voltage is amplified and then used to control I.F. gain on PC-200C.

The capacity trimmer, C1107, is the bridge null adjustment. It is adjusted by measuring reflected voltage output at the terminal which goes to PC-500D with a VTVM on its lowest scale. Use a dummy load which is known to be 50 ohms, nonreactive, set the bandswitch to the highest band, and insert a small amount of carrier in CW transmit mode, just enough to get a voltage reading. Then adjust the trimmer, C1107, for minimum voltage.

PC-1100A SWR BRIDGE, ANTENNA RELAY

C1101,1104,1105,	RL1101	RL1101DPDT 12VDC Relay
1106, 1109, 1110001 MF 100V Disc	R1101, 103	1K 10% 1/4 Watt
C1102, 110301 MF 25V Disc	R1102	150 10% 1/4 Watt
C1107	4-40pF Trimmer	D1101	1N34A Germanium Diode
C1108	200pF 5% SM	D1102,1103	1N4148 Silicon Diode
		L1101	Bifilar Toroid
		L1102	200 uH RFC

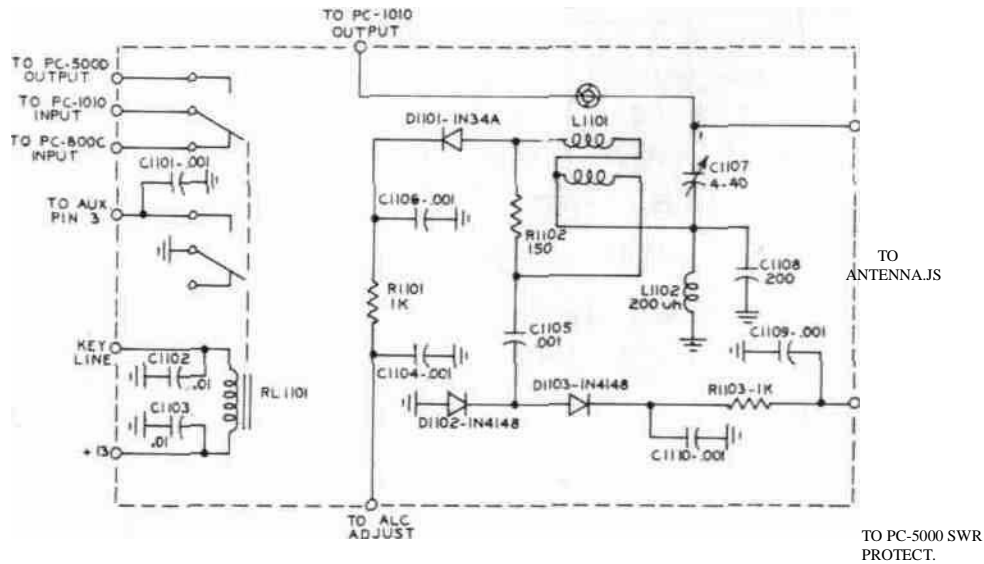

Figure 4-14. PC-1100A SWR Bridge, Antenna Relay Schematic

SECTION 5 ACCESSORIES

5-1. NOISE BLANKER MODEL PC-120

The Noise Blanker is a plug-in accessory which replaces the standard PC-100C R.F. board in Atlas transceivers. If Noise Blanker is owner or dealer installed, a threshold control which is attached to the PC-120B by a 3 wire cable, must be installed on the front panel.

CAUTION: The Carrier Balance controls have been factory set. Do not alter the 500 ohm trim pot or mica trimmer. They are located in the upper right hand corner of the PC-120B. Handle with care.

CIRCUIT DESIGN: The PC-120B noise blanker is designed specifically to blank out pulse type noise; the same as all other noise blankers. Pulse type noises, such as ignition noise will be effectively silenced, while other more continuous type noise signals will not be silenced or reduced as well. The PC-120B works on the same principle as the famous Lamb noise silencer. Noise pluses are amplified separately by Q103, rectified into *DC* pulses which are amplified by Q104, and then applied to Q105, the blanking switch. Q105 switches off Q102, the second I.F. amplifier, whenever a sharp noise pulse comes through from the antennae circuit. The threshold control, R120, is located on the front panel, and controls the gain of Q103. A second threshold control, R128, is a trimpot located on the PC-120B circuit board, and is factory adjusted so that noise pulses will switch Q105 completely, but not excessively.

OPERATION:

- (a) When the threshold control is in full counterclockwise position the noise blanker is OFF.
- (b) Advancing the control clockwise will increase the gain of Q103 until noise pulses will begin to control Q105. At this point the audible noise level will drop sharply.
- (c) If the threshold control is advanced beyond this point, no further reduction in noise will be obtained, if the character of the noise is made up entirely of sharp pulses, it will be practically eliminated. If parts of the noise are continuous, they will still be audible. In other words, the degree of noise reduction will be directly related to what percentage of the noise is pulse type, and what percentage is of a continuous nature.
- (d) CROSS MODULATION may result from higher settings of the threshold control. This is likely particularly on the lower frequency bands when a great many very strong signals are being received on a full size antennae system. Turning the threshold control down to the threshold level will eliminate this condition, while still retaining the pulse blanking action.

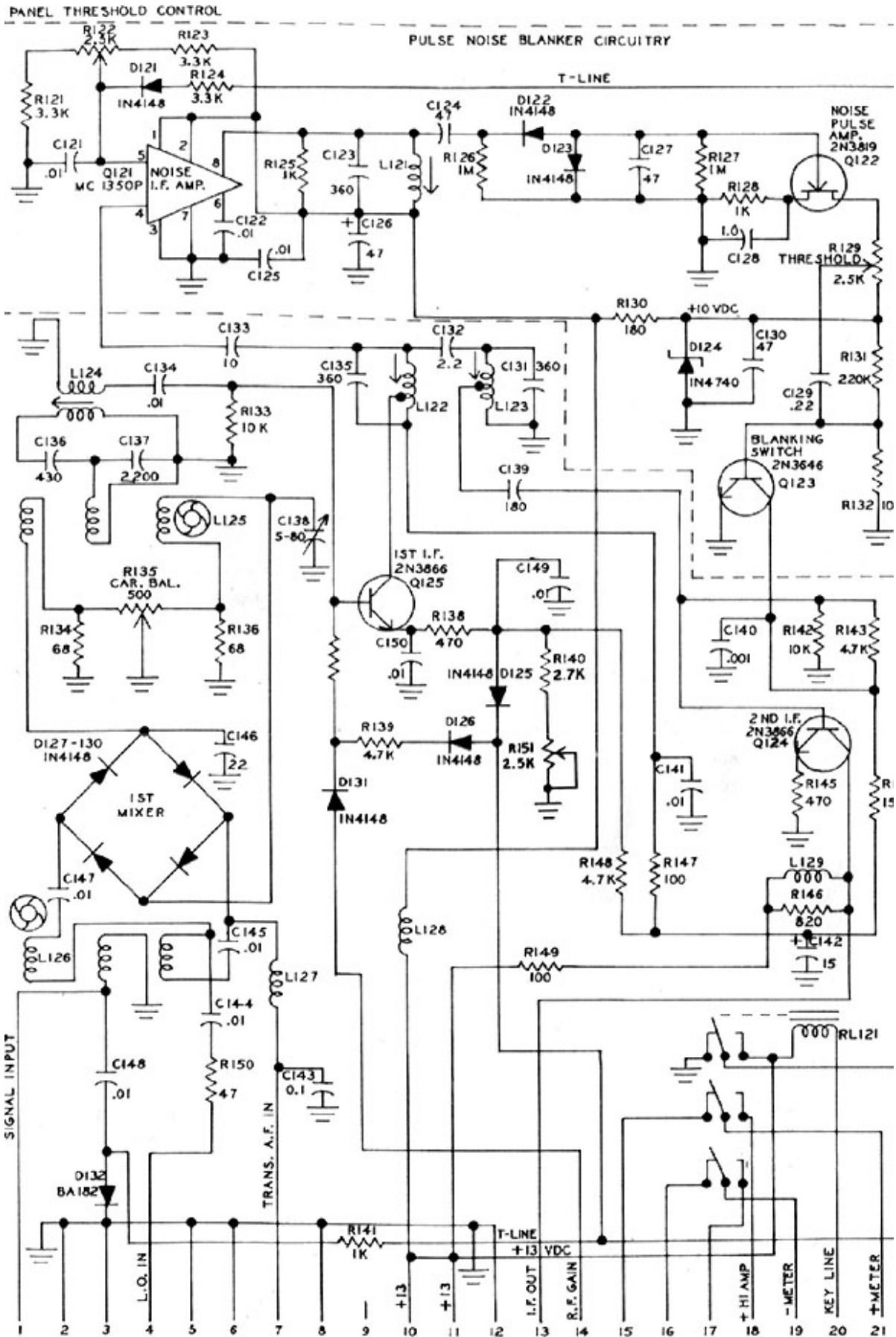

Figure 5-1. Noise Blanker Model PC-120

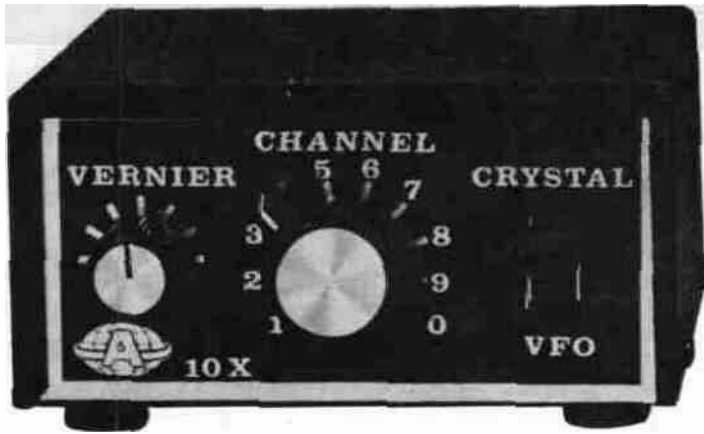

Figure 5-2. Model 10x

5-2 MODEL 10X CRYSTAL OSCILLATOR

The Model 10x oscillator provides for added versatility with the Atlas transceivers by crystal controlling the operating frequency. Vernier frequency adjustment is provided and a switch selects either crystal or VFO control. A ten position switch allows selection of up to ten crystal frequencies.

FREQUENCY RANGE WITH MODEL 10x :

- Band Range 160M 1800-3000 kHz
- 75M 3000-5 200 kHz
- 40M 5800- 10,000kHz
- 20M 13,800-14,900kHz
- 15M 20,600- 21,600kHz

Note: The Model 10x will not operate on the 28 MHz band.

INSTALLATION:

A 9 pin Noval socket on the back of the Atlas transceiver is labeled EXT. OSC. The 10x plugs into this socket. It will be necessary to remove the two jumper wires plugged in between pins 2 and 3; and pins 5 and 6. Once the wires have been removed, the transceiver VFO will not function unless the 10x is plugged in and switched to its VFO position, or the dummy jumper, which is furnished with the 10x, is inserted in the EXT. OSC. socket.

CRYSTAL REQUIREMENTS FOR THE 10X:

The crystal sockets in the 10x are designed for type HC6U crystals with standard .050 inch diameter pins. Crystals must be ordered for oscillation at parallel resonance with 20 pF shunt capacity. A frequency tolerance of .0025 per cent at 25 degrees Centigrade is adequate.

Note: The sideband selector switch on the Atlas transceiver changes carrier frequency from 5520 kHz in NORM. position, to 5523.3 in OPP. position. The Norm. position produces lower sideband operation on 160, 75, and 40 meters, which is normal operation on those amateur bands. On 20 and 15 meters, the transceiver circuitry automatically produces upper sideband in the NORM. position, which is normal for these bands.

CALCULATION OF CRYSTAL FREQUENCY:

For operation on lower sideband (LSB):

Bands 160, 75, 40 meters,
 (Sideband Selector in NORM. position.) Crystal Frequency equals Signal Frequency plus 5520 kHz. Example: 4020 + 5520 = 9540

Bands 20 and 15 meters,
 (Sideband Selector in OPP. position.) Crystal Frequency equals Signal Frequency minus 5523.3 kHz Example: 14,370 - 5523.3 = 8846.7 kHz

For operation on upper sideband (USB):

Bands 160, 75, 40 meters,
 (Sideband Selector in OPP. position.) Crystal Frequency equals Signal Frequency plus 5523.3 kHz Example: 4020 + 5523.3 = 9543.3

Bands 20 and 15 meters,
 (Sideband Selector in NORM. position.) Crystal Frequency equals Signal Frequency minus 5520 kHz Example: 14,370 - 5520 = 8850 kHz

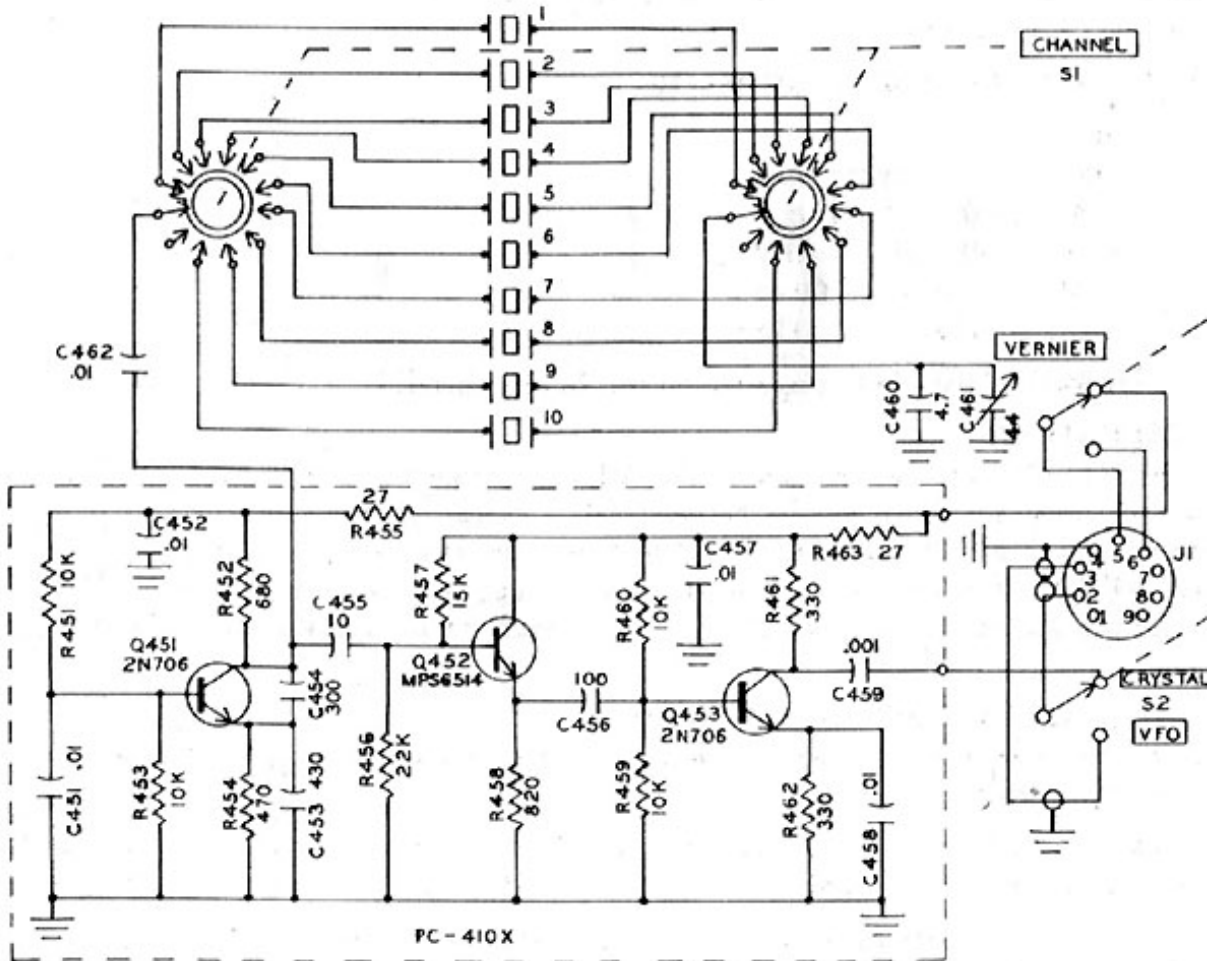

Figure 5-3. Model 10x Crystal Oscillator

5-3. Model MT-1

The MT-1 transformer is designed to provide a proper impedance match between the HF (High Frequency) mobile antennae and the 50 to 53.5 ohm coaxial feedline. It is particularly useful when the HF Transceiver is one of the new solid state, broadbanded designs which requires a close match to a 50 to 53.5 ohm non-reactive load. Practically none of the mobile antennae currently on the market will match the coaxial feedline closely enough to provide a proper load for the broadbanded amplifier. With the Atlas MT-1 transformer a tap selection will be found which will provide SWR readings of 1.4 or less when using the common type mobile antennae, such as those manufactured by Nutronics, Swan, and HyGain.

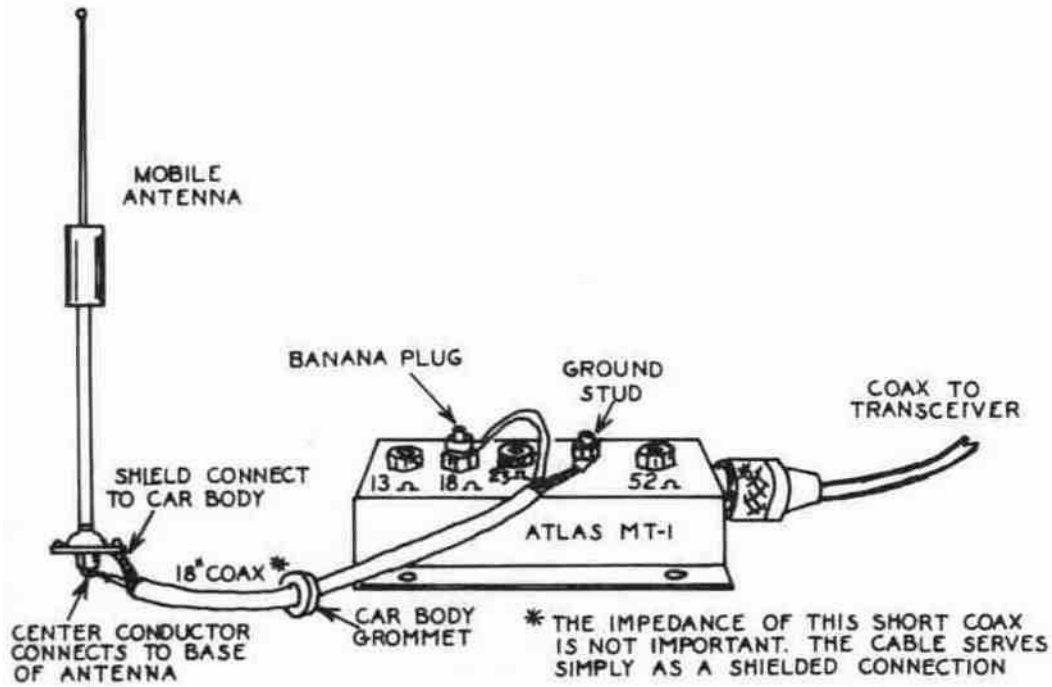

Figure 5-4. MT-1 Transformer Installation

5-4. Model VX-5 VOX

The Model VX-5 is the VOX accessory that is installed in the lower section of the Model 220-CS Console. Controls for VOX Gain, Anti-VOX, and Delay are brought out to the console front panel. AC consoles may be ordered with VOX installed, or can be easily owner or dealer installed.

5-5. Model DD-6B Digital Dial with built-in Frequency Counter Capability

In addition to being a digital dial, the DD-6B will also function as a sensitive frequency counter from 100 Hz to 40 MHz, for general use around the ham shack or lab. Input terminals and selector switch for this function are located on the rear panel.

- DIGITAL HOLD provides frequency memory which holds the digital display. This allows you to tune to other frequencies while retaining the frequency reading you expect to return to.
- Another new feature now provides for correct reading on opposite sideband, as well as the normally used sideband.
- All L.E.D. Dot Matrix 6 digit display reads within 100 Hz (just 1/10 kHz) of your actual operating frequency.
- Bright display clearly visible under high ambient light.
- Reads on both Receive and Transmit.
- Measures 1 3/8 high x 5 3/8 wide x 5 7/8 deep.

ATTENTION SWAN OWNERS

In addition to operating with all Atlas transceivers, the DD-6B can be made to operate with Swan models 350C, 500C, 500CX, 700CX, 270, 270B, 300B, 600R, and 600T.

ATTENTION DRAKE R4 AND EARLIER MODEL SWAN OWNERS

The DD-6C model is the same in all respects as the DD-6B, except that it is modified to operate with the Drake R4 series as well as the earlier Swan models 350, 400, and 500.

Instructions furnished with both models of the Digital Dial give complete information on the minor modifications required for use with Swan and Drake units. DD6-B or DD-6C

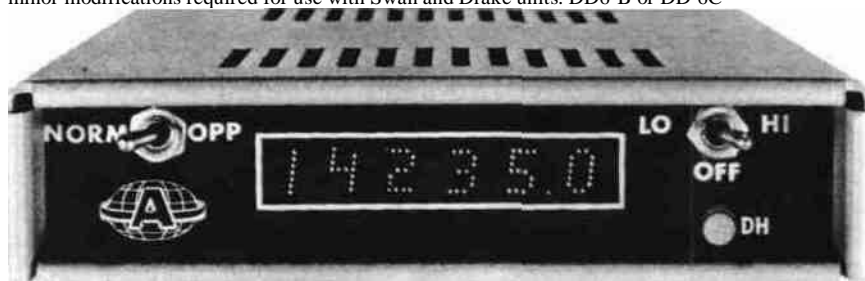

Figure 5-5. Model DD-6

MODEL 210x/215x CHASSIS COMPONENTS

PC-100C First I.F. Amplifier, First Mixer Printed Circuit Board
or PC-120 Optional Noise Blanker, 1st I F Amp , 1st Mixer
PC-200C Second I.F. Amplifier, Second Mixer, S-Meter Amplifier, Mic Amplifier Printed Circuit Board
PC-300C Receiver Audio, Osc. Switch Printed Circuit Board
PC-400C VFO Printed Circuit Board
PC-500D SWR Protect, Pre-Amp, Driver, Power Amplifier Printed Circuit Board
PC-600 Carrier Osc. Printed Circuit Board
PC-800C/1200 Receiver Input Tuning Printed Circuit Board
PC-820 100 kHz Crystal Calibrator Printed Circuit Board
PC-900C Transmitter Input Tuning Printed Circuit Board
PC-1010/1020 Low Pass Filters Printed Circuit Board
PC-1100A SWR Bridge, Antenna Relay Printed Circuit Board
J1 3 Conductor, Closed Circuit, Enclosed A.F. Output Jack
J2 3 Conductor, Open Circuit, Enclosed Mic. Jack
J3 Banana Jack
j4 9 Pin Mica Tube Socket
j5 Coaxial Receptacle
J6 9 Pin Mica Tube Socket
J7 2 Conductor, Closed Circuit, Enclosed CW Key Jack
P1,P2 Banana Plugs
M1 S-Units/P.A. Amps 500 uA Meter
FL1 5520.3-5523.0 8 Pole Crystal Ladder Filter
S1,S2 SPDT Slide Switch
S3 1 Section, 5 Position Switch
S4 5 Section, 5 Position Switch
L1,L2,L3 14V Lamps
E1 4 Ohm Speaker
C1 470PF 5% SM
C2,3,501 MF 100V Disc
C422MF 100V Mylar
C61MF 50V Disc
C7 1000MF 25V Electro.
D1 1N4148 Silicon Diode
D2 1N5221 2.4V Zener Diode
L11uH Toroid
Q1 , . . 78L06AC I.C. Volt. Reg.
R1 47K 10% 1/4W
R2,8,15 1K 10% 1/4W
R33.3K 10% 1/4W
R4 10K A.F. Gain Pot.
R54.7K 10% 1/4W
R6 10K, R.F. Gain Pot.
R7 47010% 1/2W
R9 105%1W
R10 275% 1W
R11,12 .	10K,ALC,Mic.Gain Dual Pot
R13 10K 10% 1/4W
R14 10K 10% 1/4W

ATLAS WARRANTY

THE ATLAS-210x/215x IS GUARANTEED UNDER THE FOLLOWING SCHEDULE:

- (1) All components except semiconductors are guaranteed for one (1) year from date of original purchase.
- (2) All semiconductors are guaranteed for (90) ninety days from date of original purchase.
- (3) Workmanship is guaranteed unconditionally for one (1) year from date of original purchase.
- (4) If factory service is required within 30 days Atlas will pay surface freight both ways. After 30 days customer pays shipping cost to the factory, and Atlas pays return freight. After 1 year, customer pays both ways, plus a nominal service charge.
- (5) This warranty will be transferred to owners other than original purchaser, provided the new owner advises Atlas Radio in writing of his name, address, and date of purchase.

UNDER THE REGULATIONS OF THE MAGNUSON-MOSS WARRANTY ACT, THE ATLAS WARRANTY POLICY IS CLASSIFIED AS A LIMITED WARRANTY.

ATLAS RADIO, INC.
417 Via Del Monte
Oceanside, California
92054 (714)433-1983